

Table VII. Ultrasonic Velocity at 10 MHz in Mixtures of Sodium Dodecanoate in Dodecanoic Acid

| T , K | u , m/s | $10^6 \beta_s$, bar ⁻¹ | T , K | u , m/s | $10^6 \beta_s$, bar ⁻¹ |
|----------------|--------------------|------------------------------------|---------|--------------------|------------------------------------|
| $x_1 = 0.9490$ | | | | | |
| 318.4 | 1280. ₅ | 69.3 | 328.2 | 1248. ₉ | 73.5 |
| 321.5 | 1272. ₄ | 70.4 | 332.2 | 1237. ₈ | 75.1 |
| 324.4 | 1262. ₂ | 71.7 | 335.7 | 1222. ₉ | 77.2 |
| $x_1 = 0.8600$ | | | | | |
| 327.2 | 1258. ₈ | 71.4 | 337.7 | 1224. ₄ | 76.2 |
| 330.2 | 1249. ₉ | 72.6 | 341.4 | 1214. ₃ | 77.7 |
| 333.7 | 1235. ₄ | 74.5 | | | |
| $x_1 = 0.7030$ | | | | | |
| 333.2 | 1250. ₈ | 71.1 | 340.2 | 1230. ₉ | 73.8 |
| 336.7 | 1240. ₆ | 72.5 | 344.2 | 1215. ₀ | 76.1 |

the formula $\beta_s = (u^2 d)^{-1}$ is fitted by the equation $10^6 \beta_s = -87.7 + 0.43517 + 13.368(1 + 0.001397)x_1$, where β_s is expressed in bar⁻¹, with a standard deviation of 0.2.

Acknowledgment

Thanks are due to L. Amici for technical assistance.

Glossary

| | |
|-----------|--|
| d | density |
| η | coefficient of viscosity |
| β_s | coefficient of adiabatic compressibility |
| m | molality |
| M | molar weight |
| n | number of moles |

| | |
|-------------|--|
| r | correlation coefficient |
| r_+ | cation radius |
| N | Avogadro's number |
| x_{1E} | mole fraction of component 1 in the eutectic mixture |
| x_{1P} | mole fraction of component 1 in the peritectic mixture |
| T^0 | melting temperature of the pure compound |
| T_E | eutectic temperature |
| T_P | peritectic temperature |
| u | ultrasonic velocity |
| \bar{V}_j | molar volume = $(\partial V / \partial n_j)_{T,P,n_i}$ |
| V_m | mean volume = $V / (n_1 + n_2)$ |
| V_{intr} | intrinsic volume |

Literature Cited

- (1) Vitall, G.; Berchiesi, M. A.; Berchiesi, G. *J. Chem. Eng. Data* **1979**, *24*, 169.
- (2) Castellani, F.; Berchiesi, G.; Pucclarelli, F.; Bartocci, V. *J. Chem. Eng. Data* **1981**, *26*, 150.
- (3) Gioia Lobbia, G.; Berchiesi, G.; Berchiesi, M. A. *J. Thermal Anal.* **1976**, *10*, 137.
- (4) Berchiesi, G.; Berchiesi, M. A.; Gioia Lobbia, G. *J. Chem. Eng. Data* **1981**, *26*, 20.
- (5) Berchiesi, G.; Gioia Lobbia, G.; Berchiesi, M. A. *J. Chem. Eng. Data* **1980**, *25*, 9.
- (6) Braghetti, M.; Leonesi, D.; Franzosini, P. *Ric. Sci.* **1968**, *38*, 116.
- (7) Berchiesi, M. A.; Berchiesi, G.; Vitall, G. *Ann. Chim. (Rome)* **1975**, *65*, 669.
- (8) Berchiesi, G.; Leonesi, D.; Cingolani, A. *J. Thermal Anal.* **1975**, *7*, 659.
- (9) Bondi, A. *J. Phys. Chem.* **1964**, *68*, 441.

Received for review April 7, 1981. Revised manuscript received October 20, 1981. Accepted November 19, 1981. CNR (Rome) provided financial support for this work.

Relative Volatilities of the Ethane-Ethylene System from Total Pressure Measurements

David A. Barclay, Judith L. Flebbe, and David B. Manley*

Chemical Engineering Department, University of Missouri—Rolla, Rolla, Missouri 65401

A new apparatus has been developed for making vapor pressure measurements on high-pressure systems. Using this equipment, we have made a large number of new total pressure measurements on the ethane-ethylene binary from 198.15 to 278.15 K. By integration of the general coexistence equation, relative volatilities have been calculated for ethane-ethylene over the entire temperature range.

The viability of using the total pressure method for determining relative volatilities in systems at high pressure has been shown by Manley (1) and Manley and Swift (2). Walker (3) and Steele (4, 5) have developed an apparatus capable of producing rapid and accurate P - T - X measurements for moderate-pressure systems at near ambient temperatures. Barclay (6) incorporated the desirable features of that equipment into an apparatus useful at higher pressures and lower temperatures and provides new data on a system of economic significance.

No recent study of the ethane-ethylene system has been made which covers the entire region of industrial interest. Fredenslund et al. (7) produced high-quality VLE measurements for two isotherms, 263.15 and 293.15 K, the second being

above the critical point of ethylene. Earlier measurements by Hanson et al. (8) at 273.15, 233.17, and 199.85 K are not of comparable accuracy. The results of this study should improve the consistency and the accuracy of the relative volatility information on the ethane-ethylene system and aid in the design of distillation columns for processing these two chemicals.

Experimental Equipment

The equipment developed to measure vapor pressures is very similar to that described by Walker and Steele. It was designed to operate at pressures up to 4.5 MPa with the capability of being easily modified to work almost to 7.0 MPa.

A major equipment modification was the redesign of the sample cell-transducer combination. Figure 1 is a proportional drawing of these.

The cell is constructed of 316 stainless steel with a 0.002-in. type 302 stainless diaphragm and is assembled by silver solder brazing. The cavity is machined from 2-in. disks approximately $1/8$ in. thick. The diameter of the cavity is 1.50 in., and it is cut at a lathe setting of 1.5° for the entire radius to give a maximum span at the center of about 0.031 in. The sample chamber is made from 1-in. o.d. tubing and has an approximate

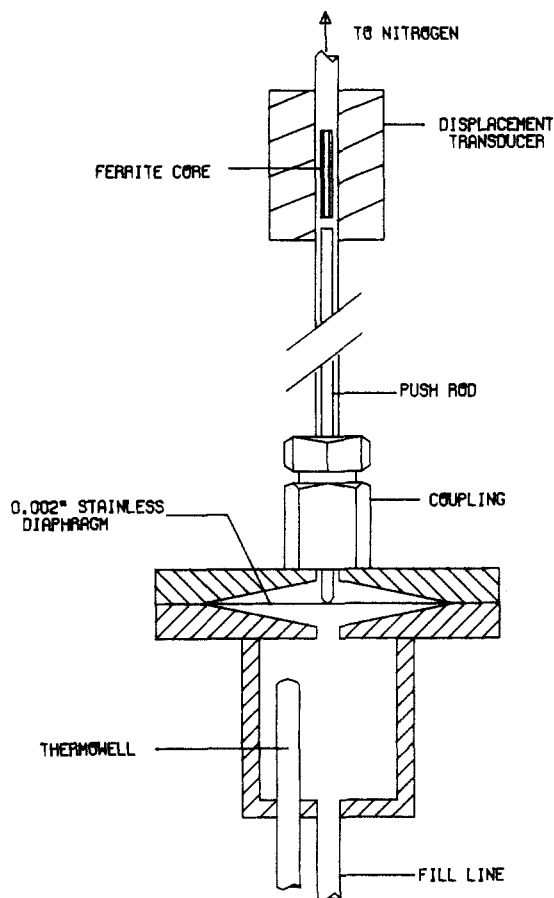

Figure 1. Cell and transducer for vapor pressure measurements.

volume of 6 cm³. The thermowell provides a way to get accurate temperature measurements of the fluid in the cell. Tare weight of the cell plus the valve attached to the fill line is less than 220 g. The maximum working pressure is about 7.0 MPa.

The transducer which attaches to the cell serves to sense the position of the cell diaphragm, to support the cell in the temperature bath, and to connect the upper cell cavity to the nitrogen system used for balancing the diaphragm. The push rod is located inside the connecting line and rests on the diaphragm. Movement of the diaphragm causes the rod to move a small powdered iron core connected to its upper end. A Trans-Tek Model 240-000 displacement transducer senses the core position. Output from the transducer is read on a digital millivoltmeter.

In actual operation, the cell-transducer combination is calibrated as a unit to find the diaphragm null as a function of temperature and pressure. The unit is sensitive to pressure differentials of less than 68.95 Pa at pressures up to 3.0 MPa. Sensitivity appears to decrease slightly at higher pressures. After a complete "overpressure" on the diaphragm of 7.0 MPa, the calibration accuracy is retained to better than ± 138 Pa.

Constant temperature was provided in an air bath as shown in Figure 2. A small squirrel cage fan circulates air down the center or working space of the bath and then forces it back up the annulus where the cooling coil and the heaters are located. An FTS Systems two-stage refrigeration unit provides cooling. The heaters are bare wire nichrome heating elements. A Bayley proportional band controller is used for temperature control. The inner and outer shells are cast acrylic tubing. They measure 6 × 18 and 9 × 30 in., respectively. The internal parts are supported by six 0.25-in. stainless threaded rods while the outer shell is held only by the end plates and may be removed for easy access to the interior. The bath is insulated by stacking shaped foam planks around it. The range of op-

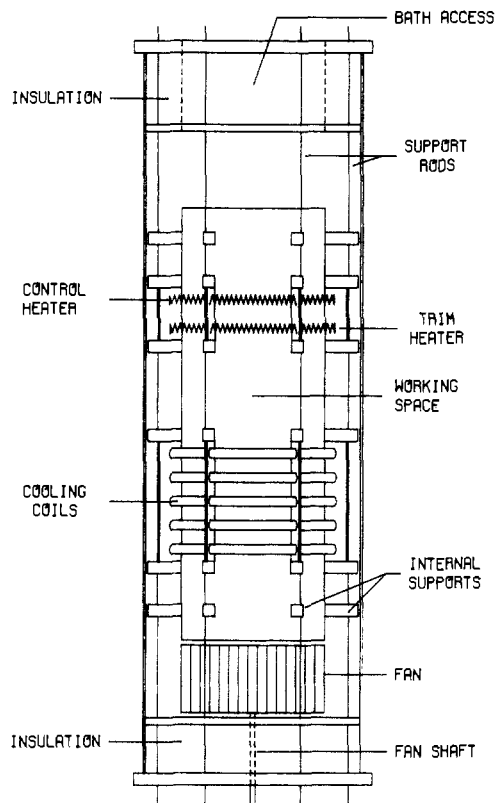

Figure 2. Air bath.

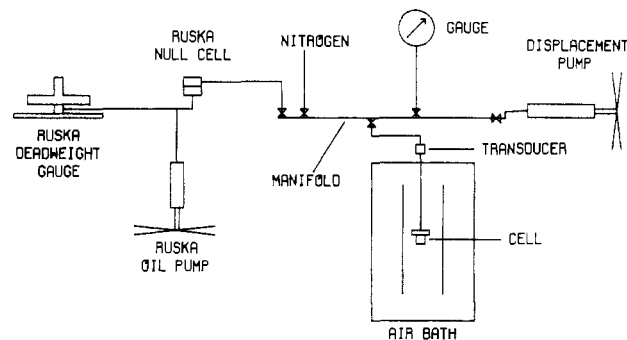

Figure 3. Schematic of system for vapor pressure measurements.

eration is -80 to 20 °C, and temperature control of the cells located in the bath was better than ± 0.01 °C.

Loading of cells proceeded in the following manner. The evacuated tare of the cell was established to better than 0.1 mg by replicate weighings over a period of 12 h. The cell was attached to a small fill manifold which connected the cell, the sample container, and a gauge to the vacuum-vent system. After evacuation, the system was flushed several times with the component to be charged to the cell. Sample was transferred to the cell by first filling the gauge and connecting lines with fluid from the sample cylinder, closing it off, and then opening the fill valve on the cell. The amount of sample was then determined by weighing the cell and contents. For binary mixtures ethane was added first with the sample cylinder being inverted to get liquid sample. Gentle heat was applied to increase cylinder pressure and improve the transfer of liquid ethane to the cell. This was not necessary for ethylene. When ethylene was added, the above process was repeated. The manifold would be filled with ethylene to a pressure above that in the cell and the cell valve then cracked open briefly to allow some transfer into the cell. The manifold was then filled to a higher pressure than before and the process repeated. When the maximum fill pressure was reached, the cell was weighed to

find the amount of ethylene added.

A transducer was attached to the cell and the unit was placed in the air bath and connected to the pressure measuring system shown in Figure 3. After the cell was brought to temperature in the bath and the rough pressure found by using the gauge on the nitrogen system, the cell null was calculated. The displacement pump was used to make minor pressure adjustments to bring the diaphragm in the cell to a final null. The pressure was measured through the Ruska null cell by a Ruska oil dead-weight gauge.

Temperatures were measured by using Rosemount Model 146MA100F platinum resistance thermometers placed in the thermowells of the cells. Each thermometer was calibrated to IPTS-68 by comparison with a standard thermometer calibrated by NBS. Resistances were measured by using a Rubicon Instruments Mueller type bridge and a L & N dc null detector.

The ethane and the ethylene used in this study were research-grade purity, listed as 99.96% and 99.95% pure, respectively, purchased from Phillips Petroleum Co. Samples of each were prepared by subjecting them to a series of freeze-thaw cycles to remove traces of air. Chromatographic analyses of the gas phase of the ethane and of the ethylene revealed no detectable traces of air in either. This amounts to less than 6 ppm by weight. No other impurities were detected.

Theory

The rigorous form of the isothermal binary Gibbs-Duhem equation was integrated to find vapor compositions from the total pressure measurements

$$\frac{dy}{dx} = \frac{\left\{ y(1-y) \frac{\Delta'V}{(y-x)} - y(1-y) \left[\frac{\partial \ln(\phi_1/\phi_2)}{\partial P} \right]_y \right\} \frac{dP}{dx}}{1 + y(1-y) \left[\frac{\partial \ln(\phi_1/\phi_2)}{\partial y} \right]_P} \quad (1)$$

where the partial derivatives of $\ln(\phi_1/\phi_2)$ are constrained to constant vapor composition or constant pressure as indicated and

$$\Delta'V = (1/RT)(V^v - V^l) \quad (2)$$

The development of eq 1 has been given by Manley and Swift (2), who also derive the limiting forms as x approaches the composition extremes

$$\lim_{x \rightarrow 0} dy/dx = \lim_{x \rightarrow 0} \alpha = 1 + \Delta'V(dP/dx) \quad (3)$$

$$\lim_{x \rightarrow 1} dy/dx = \lim_{x \rightarrow 1} \alpha = 1/[1 - \Delta'V(dP/dx)] \quad (4)$$

In the ideal total pressure measurement experiment, the cell is filled with liquid so only a small vapor space remains. The overall cell composition, which is measured, then very closely approximates the liquid composition. For most cases a correction of the overall composition, z , to the liquid composition, x , is required. Using the material balance and phase relations for the contents of the cell, the correction of z to x is easily found

$$x = z\rho_0/[X\rho_l - X\rho_vK + K\rho_v] \quad (5)$$

where

$$X = (\rho_0 - \rho_v)/(\rho_l - \rho_v) \quad (5a)$$

Using eq 1 and 5 the integration at each isotherm is combined with the composition corrections as Gibbs and Van Ness (9) have indicated. The initial P - z data are curve fitted, and the integration is performed. With this initial estimate of K 's

Table I. a Constant^a for Redlich-Kwong Equation

| T , K | ethane | ethylene | T , K | ethane | ethylene |
|---------|--------|----------|---------|--------|----------|
| 278.15 | 0.6095 | 0.4737 | 218.15 | 0.7226 | 0.5576 |
| 263.15 | 0.6349 | 0.4933 | 203.15 | 0.7548 | 0.5818 |
| 248.15 | 0.6646 | 0.5130 | 198.15 | 0.7660 | 0.5902 |
| 233.15 | 0.6921 | 0.5347 | | | |

^a Units: (L/mol)² MPa.

and y values, eq 5 is applied to give corrected x values. The process is repeated until the x values no longer change within established error bounds. Convergence was found to occur generally within 2-3 iterations.

The integration algorithm was an Adams-Moulton predictor-corrector procedure of order 5 (10). A fourth-order Runge-Kutta procedure was used to start the integration which proceeded in the direction of increasing pressure.

Curve fitting of the isothermal P - x data was done with an equation based on deviations from Raoult's law. A three-constant Redlich-Kister equation was used to fit the deviations

$$\ln(P/P_R) = x(1-x)[B + C(2x-1) + D(2x-1)^2] \quad (6)$$

where P_R is the Raoult's law pressure. Equation 6 provided both the total pressure and its derivatives for the integration.

For saturated vapor volumes and the partial derivatives involving the fugacity coefficients, a Redlich-Kwong-type equation was used (11)

$$P = \frac{RT}{V-b} - \frac{a}{V(V+b)} \quad (7)$$

where

$$b_i = 0.08664RT_c/P_c \quad (8)$$

and the a constant was adjusted at each isotherm to give the proper vapor compressibility factors for the pure components. The established mixing rules were relied upon for the mixture properties.

$$a = \sum_i y_i [\sum_j y_j (a_{ij})^{1/2} (1 - \delta_{ij})] \quad (9)$$

$$b = \sum_i y_i b_i \quad (10)$$

Saturated liquid volumes were calculated from the correlation by Hankinson and Thomson (12)

$$V_s/V^* = V_R^0 [1 - \omega V_R^\delta] \quad (11)$$

where V_R^0 and V_R^δ are given as functions of reduced temperature. The adjustable parameter, V^* , was used to calibrate the equation to the pure-component volumes at each temperature. Their suggested mixing rules were used to calculate saturated volumes for mixtures of ethane and ethylene.

The pure-component P - V - T data on both ethane and ethylene given by Douslin and Harrison (13, 14) were used to calibrate the equations for saturated vapor and liquid volumes. These data were chosen not only for their accuracy and precision but for the fact that the saturated liquid and vapor volumes are internally consistent. Since eq 1 requires the difference between liquid and vapor volumes, this is very important.

Table I gives the a constants used in the vapor equation of state. The critical temperatures and pressures used were those given by Douslin and Harrison: for ethane, $T_c = 305.33$ K and $P_c = 4.8717$ MPa; for ethylene, $T_c = 282.35$ K and $P_c = 5.0419$ MPa. The interaction coefficient was estimated as 0.0125 by fitting the data of Fredenslund et al. (7) with the Soave-Redlich-Kwong VLE algorithm.

The liquid volume constants used are in Table II. Accentric factors were 0.0983 for ethane and 0.882 for ethylene as

Table II. Characteristic Volumes for Saturated Liquid Density Equation

| ethane | | ethylene | |
|---------------|--------------|---------------|--------------|
| T, K | $V^*, L/mol$ | T, K | $V^*, L/mol$ |
| 278.15–198.15 | 0.1458 | 278.15 | 0.13183 |
| | | 263.15 | 0.13161 |
| | | 248.15 | 0.13133 |
| | | 233.15–198.15 | 0.1310 |

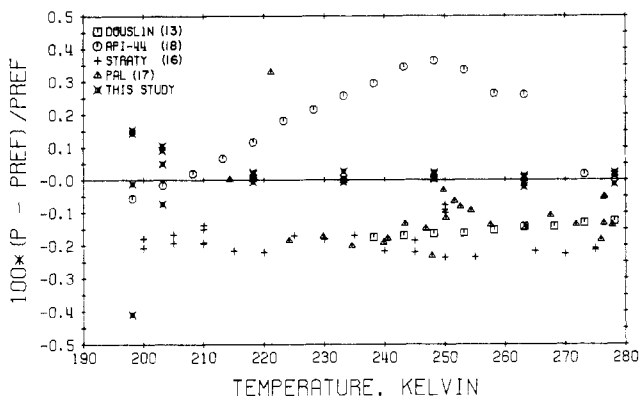

Figure 4. Literature comparisons for ethane.

suggested in the original correlation.

Results

Vapor pressures were measured for both pure ethane and ethylene and 13 mixtures at 7 temperatures. Each set of measurements was at constant overall composition. Duplicate points were taken for each temperature, the first while proceeding in the direction of decreasing temperature and the second while proceeding with increasing temperature. Two separate sets of measurements were made on the pure components, one at the beginning of the study and one at the end, using different cells and different thermometers. This helped to establish the precision of the equipment and verified the purity of the ethane and ethylene. All of the raw data were corrected to even temperatures before further use.

In order to make the correction from overall composition to liquid composition, it was necessary to find the volumes of the cells. Calibration of the cell volumes as a function of temperature and pressure was done with compressed liquid propane. The densities of propane were taken from Ely and Kobayashi (15).

Figure 4 shows the comparison for ethane vapor pressures of more recent literature data with this study. The data of Douslin and Harrison (13), Straty and Tsumura (16), Pal et al. (17), and this work all show general agreement within $\pm 0.25\%$. The API-44 (18) correlation represents earlier data. Reference pressures were calculated by using the Goodwin equation (20) fitted to the data from this investigation

$$\ln(P/P_r) = A\chi + B\chi^2 + C\chi^3 + D\chi(1-\chi)^\epsilon \quad (12)$$

where

$$\chi = (1 - T_b/T)/(1 - T_b/T_c) \quad (13)$$

P_r , T_b , T_c , and ϵ were set at 0.101325 MPa, 184.563 K, 305.33 K, and 1.43, respectively. The calculated constants are $A = 3.4245$, $B = 0.5643$, $C = -0.11647$, and $D = 0.53079$. The equation was used only for the literature comparisons.

Pure-component ethylene literature comparisons are in Figure 5. The Goodwin constants found were $A = 3.4172$, $B = 0.6557$, $C = -0.16647$, and $D = 0.58704$. T_b , T_c , P_r , and ϵ were set at 169.389 K, 282.35 K, 0.101325 MPa, and 1.46 as

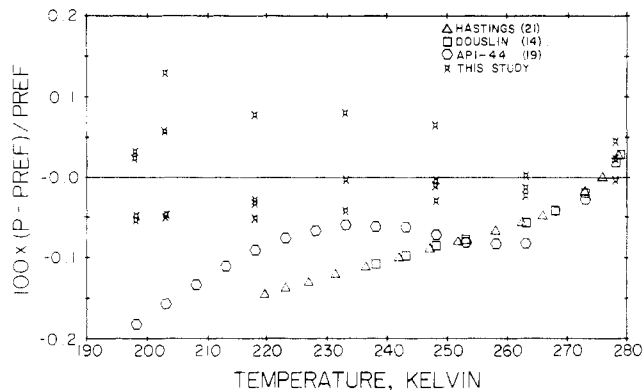

Figure 5. Literature comparisons for ethylene.

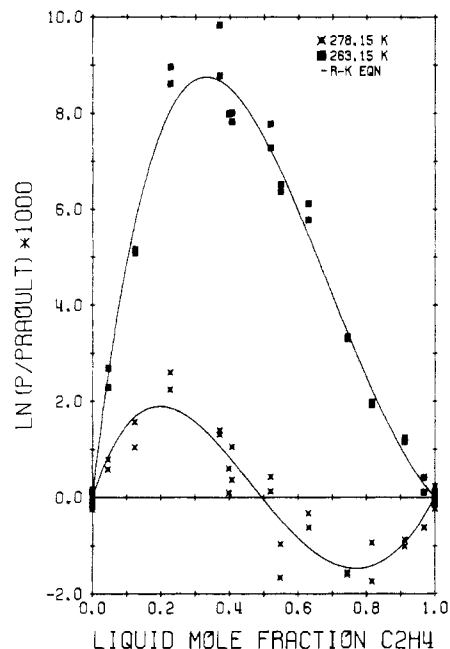

Figure 6. Raoult's law deviations for ethane-ethylene binary.

Douslin and Harrison suggest. All deviations between data sets are within $\pm 0.2\%$.

Table III shows the measured vapor pressures for the ethane-ethylene binary. The estimated probable error in pressure is given by $(0.0132\%)P + 0.00024$ MPa. Errors in temperature are believed to be within ± 0.01 K. Pressures are reported to more places than accuracy justifies to retain internal consistency. Total moles in the cell and overall composition remain constant for all temperatures. The estimated error in overall mole fractions is ± 0.0001 mole fraction units. The cell volumes are believed to be within 0.2%. The corrected x values are estimated to be accurate to ± 0.0005 mole fraction units as an average value. Since the estimate is a function of the amount of liquid in the cell, this value can vary. In the region of high ethylene composition at 278.15 K and 263.15 K, which is near the critical point, the errors in x may be larger. These should average less than 0.5% of x .

The Redlich-Kister constants used to fit the $P-x$ data for each isotherm are in Table IV. These were used in eq 6 for integration of the coexistence equation.

Figures 6–9 show the deviations from Raoult's law for all of the isotherms. These illustrate the precision of the data. For comparison, the Redlich-Kister curve fit is also plotted.

Results of the numerical integration of eq 1 are in Table V. Figure 10 is a plot of these same results.

To investigate the effect of systematic errors and errors in the calculated physical properties from the correlations on the

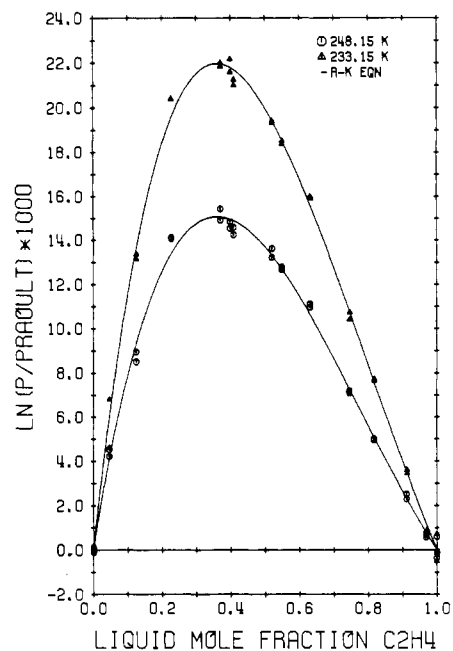

Figure 7. Raoult's law deviations for ethane-ethylene binary.

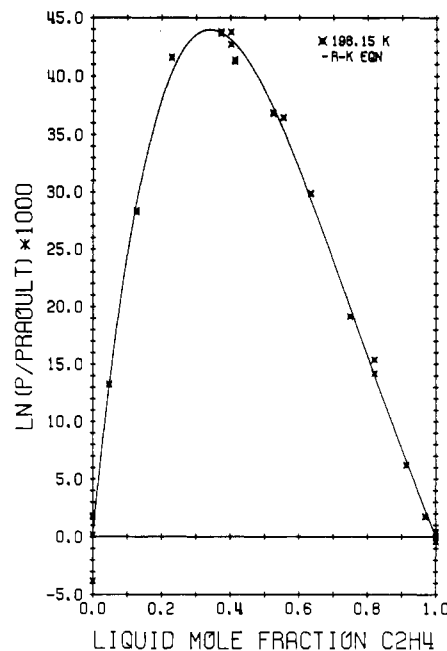

Figure 9. Raoult's law deviations for ethane-ethylene binary.

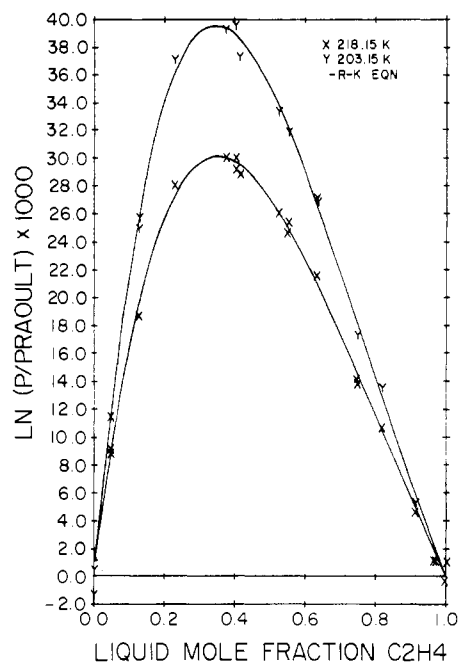

Figure 8. Raoult's law deviations for ethane-ethylene binary.

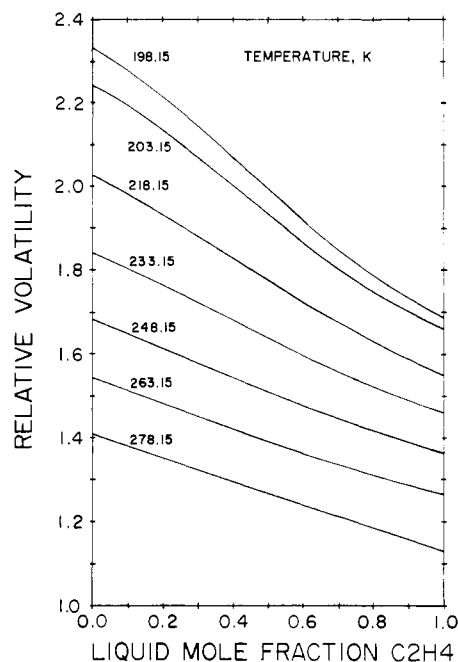

Figure 10. Relative volatility of ethylene in ethane.

integration, we deliberately introduced several types of errors into the integration. (1) The pure-component vapor pressure of ethylene was changed by 0.1%. A similar error in ethane should have the same effect. (2) The saturated vapor volume equation, eq 7, was adjusted to give vapor compressibility factors for the pure components which were in error by 0.6%. (3) The pressure equation was adjusted to give pressures in error by 0.1% at $x = 0.5$. Other types of errors were assumed to be negligible compared to these. The results are shown in Table VI.

Effects of the errors vary with temperature and composition. The error introduced in vapor compressibilities dominates at 278.15 K while the error in total pressure is largest at 198.15 K. The average error is 0.4% of α .

Figure 11 is a comparison of results of this study with literature data. Those isotherms which correspond to relative volatilities derived directly from the pressure measurements are shown as solid lines. The dashed lines were interpolated by

using the pure-component equations (eq 12) and by curve fitting the constants in Table IV with temperature. Integration of the coexistence equation then used these interpolated constants and pressures to calculate the intermediate isotherms. The data of Fredenslund et al. (7) and Hanson et al. (8) are results of sampling liquid and vapor phases at equilibrium.

Agreement is generally within the combined experimental error. At 255.38 K, the data of Hanson appear to be high at the ethylene end of the isotherm.

Conclusions

Experimental equipment has been developed which may be used to measure vapor pressures almost to 7.0 MPa and temperatures between -80 and 20 °C. This should be useful in generating more accurate and precise data on high-pressure

Table III. Vapor Pressures for the Ethane-Ethylene Binary

| x | press., MPa | cell vol, cm ³ | total mol in cell | overall mole fraction of ethylene | x | press., MPa | cell vol, cm ³ | total mol in cell | overall mole fraction of ethylene |
|----------|--------------------|---------------------------|-------------------|-----------------------------------|--------|--------------------|---------------------------|-------------------|-----------------------------------|
| 278.15 K | | | | | | | | | |
| 0.0 | 2.691 22, 2.692 18 | | | | 0.5478 | 3.728 10, 3.725 47 | 5.901 | 0.049 741 | 0.555 7 |
| | 2.691 91, 2.692 17 | | | | 0.6298 | 3.884 98, 3.886 09 | 6.250 | 0.054 091 | 0.636 46 |
| 0.0458 | 2.780 35, 2.780 92 | 6.230 | 0.042 169 | 0.0483 | 0.7440 | 4.097 49, 4.097 65 | 5.899 | 0.046 900 | 0.750 8 |
| 0.1233 | 2.928 90, 2.930 42 | 5.906 | 0.042 274 | 0.1289 | 0.8154 | 4.235 57, 4.232 14 | 5.898 | 0.043 044 | 0.822 0 |
| 0.2274 | 3.131 61, 3.130 50 | 6.237 | 0.068 138 | 0.22934 | 0.9113 | 4.417 72, 4.417 11 | 6.259 | 0.044 138 | 0.915 0 |
| 0.3703 | 3.399 14, 3.399 41 | 6.241 | 0.063 423 | 0.3740 | 0.9677 | 4.525 81, 4.525 78 | 6.261 | 0.039 679 | 0.969 5 |
| 0.3982 | 3.449 70, 3.447 97 | 5.903 | 0.057 226 | 0.4029 | 1.00 | 4.590 00, 4.591 03 | | | |
| 0.4067 | 3.465 02, 3.467 39 | 6.242 | 0.053 484 | 0.4142 | | 4.588 89, 4.589 96 | | | |
| 0.5194 | 3.678 17, 3.679 28 | 6.246 | 0.056 838 | 0.5255 | | | | | |
| 263.15 K | | | | | | | | | |
| 0.0 | 1.861 14, 1.861 79 | | | | 0.0 | 0.460 36, 0.460 43 | | | |
| | 1.861 40, 1.861 67 | | | | | 0.460 48, 0.460 50 | | | |
| 0.0461 | 1.929 64, 1.930 42 | 6.218 | | | 0.0472 | 0.485 54, 0.485 69 | 6.199 | | |
| 0.1240 | 2.043 45, 2.043 60 | 5.911 | | | 0.1264 | 0.525 70, 0.525 79 | 5.921 | | |
| 0.2269 | 2.195 00, 2.194 22 | 6.222 | | | 0.2278 | 0.576 50, 0.576 57 | 6.201 | | |
| 0.3699 | 2.396 54, 2.394 01 | 6.226 | | | 0.3716 | 0.642 83, 0.642 88 | 6.202 | | |
| 0.3983 | 2.431 75, 2.431 71 | 5.909 | | | 0.4002 | 0.655 74, 0.655 32 | 5.920 | | |
| 0.4070 | 2.443 56, 2.444 02 | 6.227 | | | 0.4106 | 0.659 80, 0.659 78 | 6.202 | | |
| 0.5194 | 2.598 75, 2.600 03 | 6.229 | | | 0.5224 | 0.708 31, 0.708 37 | 6.203 | | |
| 0.5486 | 2.637 42, 2.637 02 | 5.908 | | | 0.5519 | 0.720 73, 0.721 25 | 5.920 | | |
| 0.6300 | 2.748 72, 2.749 65 | 6.232 | | | 0.6333 | 0.755 09, 0.754 95 | 6.204 | | |
| 0.7447 | 2.901 29, 2.901 16 | 5.906 | | | 0.7478 | 0.800 34, 0.800 50 | 5.919 | | |
| 0.8163 | 2.996 35, 2.996 52 | 5.906 | | | 0.8193 | 0.829 45, 0.829 53 | 5.919 | | |
| 0.9116 | 3.126 02, 3.126 26 | 6.239 | | | 0.9136 | 0.866 11, 0.866 15 | 6.206 | | |
| 0.9679 | 3.200 60, 3.201 59 | 6.240 | | | 0.9688 | 0.887 36, 0.887 53 | 6.206 | | |
| 1.00 | 3.244 57, 3.245 03 | | | | 1.00 | 0.899 67, 0.899 84 | | | |
| | 3.244 25, 3.245 03 | | | | | 0.900 83, 0.899 87 | | | |
| 248.15 K | | | | | | | | | |
| 0.0 | 1.235 74, 1.235 79 | | | | 0.0 | 0.250 65, 0.250 33 | | | |
| | 1.235 93, 1.236 00 | | | | | 0.250 75, 0.250 78 | | | |
| 0.0464 | 1.287 02, 1.287 42 | 6.209 | | | 0.0476 | 0.266 37, 0.266 43 | 6.197 | | |
| 0.1247 | 1.370 27, 1.370 88 | 5.916 | | | 0.1272 | 0.291 83, 0.291 90 | 5.922 | | |
| 0.2270 | 1.480 24, 1.480 15 | 6.212 | | | 0.2282 | 0.323 49, 0.323 55 | 6.198 | | |
| 0.3702 | 1.624 54, 1.625 38 | 6.215 | | | 0.3723 | 0.364 33, 0.364 38 | 6.199 | | |
| 0.3984 | 1.652 09, 1.652 59 | 5.914 | | | 0.4010 | 0.372 44, 0.372 48 | 5.922 | | |
| 0.4081 | 1.661 29, 1.661 84 | 6.215 | | | 0.4117 | 0.374 61, 0.374 58 | 6.199 | | |
| 0.5202 | 1.771 44, 1.772 16 | 6.217 | | | 0.5234 | 0.404 05, 0.404 01 | 6.200 | | |
| 0.5492 | 1.799 65, 1.799 44 | 5.913 | | | 0.5531 | 0.411 67, 0.411 63 | 5.922 | | |
| 0.6309 | 1.877 73, 1.878 03 | 6.219 | | | 0.6343 | 0.431 94, 0.432 06 | 6.200 | | |
| 0.7454 | 1.984 02, 1.984 19 | 5.912 | | | 0.7488 | 0.458 98, 0.459 05 | 5.921 | | |
| 0.8170 | 2.050 76, 2.050 68 | 5.911 | | | 0.8202 | 0.476 71, 0.476 66 | 5.921 | | |
| 0.9123 | 2.139 20, 2.139 66 | 6.224 | | | 0.9141 | 0.498 02, 0.498 06 | 6.201 | | |
| 0.9682 | 2.190 67, 2.190 93 | 6.224 | | | 0.9691 | 0.510 61, 0.510 66 | 6.202 | | |
| 1.0 | 2.219 94, 2.220 39 | | | | 1.00 | 0.517 97, 0.517 99 | | | |
| | 2.222 04, 2.220 51 | | | | | 0.518 52, 0.518 89 | | | |
| 233.15 K | | | | | | | | | |
| 0.00 | 0.779 15, 0.779 13 | | | | 0.0 | 0.199 21, 0.200 00 | | | |
| | 0.779 06, 0.779 31 | | | | | 0.200 31, 0.200 33 | | | |
| 0.0468 | 0.814 54, 0.816 33 | 6.203 | | | 0.0476 | 0.213 40, 0.213 39 | 6.197 | | |
| 0.1255 | 0.875 37, 0.875 56 | 5.919 | | | 0.1274 | 0.234 91, 0.234 88 | 5.923 | | |
| 0.2274 | 0.951 91, 0.951 92 | 6.205 | | | 0.2284 | 0.261 49, 0.261 47 | 6.198 | | |
| 0.3709 | 1.052 34, 1.052 51 | 6.207 | | | 0.3725 | 0.295 56, 0.295 61 | 6.199 | | |
| 0.3993 | 1.071 63, 1.072 25 | 5.917 | | | 0.4012 | 0.301 96, 0.302 27 | 5.922 | | |
| 0.4094 | 1.077 97, 1.078 25 | 6.207 | | | 0.4120 | 0.304 02, 0.304 07 | 6.199 | | |
| 0.5213 | 1.153 21, 1.153 31 | 6.209 | | | 0.5237 | 0.328 47, 0.328 49 | 6.199 | | |
| 0.5506 | 1.172 29, 1.172 45 | 5.917 | | | 0.5535 | 0.335 24, 0.335 25 | 5.922 | | |
| 0.6321 | 1.225 34, 1.225 45 | 6.210 | | | 0.6346 | 0.351 65, 0.351 67 | 6.200 | | |
| 0.7467 | 1.296 75, 1.297 17 | 5.916 | | | 0.7490 | 0.373 89, 0.373 90 | 5.922 | | |
| 0.8182 | 1.341 87, 1.341 98 | 5.916 | | | 0.8205 | 0.388 64, 0.388 19 | 5.922 | | |
| 0.9130 | 1.400 42, 1.400 64 | 6.213 | | | 0.9142 | 0.406 09, 0.406 10 | 6.201 | | |
| 0.9686 | 1.434 31, 1.434 42 | 6.213 | | | 0.9691 | 0.416 57, 0.416 54 | 6.201 | | |
| 1.00 | 1.453 66, 1.454 20 | | | | 1.00 | 0.422 55, 0.422 52 | | | |
| | 1.455 43, 1.454 23 | | | | | 0.422 85, 0.422 88 | | | |

and low-temperature systems for design and correlation work.

A significant number of new vapor pressure measurements have been made on the ethane-ethylene binary. By integration of the general coexistence equation, relative volatilities have been determined over the range 198.15–278.15 K with a

probable error of $\pm 0.4\%$.

Glossary

K y/x
P pressure, MPa

Table IV. Constants for Total Pressure Equation

| T, K | pure-component press., MPa | | 1000(Redlich-Kister eq constants) | | |
|--------|----------------------------|----------|-----------------------------------|------------|-----------|
| | ethane | ethylene | B | C | D |
| 278.15 | 2.691 87 | 4.589 97 | -0.199 512 8 | -17.406 32 | 4.372 535 |
| 263.15 | 1.861 50 | 3.244 71 | 29.998 38 | -26.628 31 | 4.513 233 |
| 248.15 | 1.235 86 | 2.220 72 | 54.798 05 | -36.285 65 | 5.796 761 |
| 233.15 | 0.779 16 | 1.454 38 | 80.019 92 | -52.052 10 | 9.858 286 |
| 218.15 | 0.460 45 | 0.900 06 | 108.491 7 | -73.572 78 | 21.324 98 |
| 203.15 | 0.250 63 | 0.518 34 | 140.084 4 | -103.852 1 | 30.009 63 |
| 198.15 | 0.199 97 | 0.422 70 | 155.066 2 | -116.000 0 | 35.684 77 |

Table V. Results of Integration of Binary Gibbs-Duhem Equation

| x | y | P | ν^1 | Z | α | x | y | P | ν^1 | Z | α |
|----------|--------|----------|----------|--------|----------|----------|--------|----------|----------|--------|----------|
| 278.15 K | | | | | | 0.5000 | 0.6206 | 1.139 34 | 0.061 72 | 0.8200 | 1.636 |
| 0.0000 | 0.0000 | 2.691 87 | 0.077 34 | 0.6525 | 1.409 | 0.6000 | 0.7051 | 1.204 36 | 0.061 50 | 0.8130 | 1.594 |
| 0.1000 | 0.1329 | 2.885 96 | 0.077 71 | 0.6364 | 1.379 | 0.7000 | 0.7839 | 1.267 89 | 0.061 30 | 0.8062 | 1.555 |
| 0.2000 | 0.2523 | 3.077 30 | 0.078 18 | 0.6196 | 1.350 | 0.8000 | 0.8587 | 1.330 43 | 0.061 12 | 0.7996 | 1.519 |
| 0.3000 | 0.3615 | 3.266 41 | 0.078 76 | 0.6022 | 1.321 | 0.9000 | 0.9305 | 1.392 45 | 0.060 95 | 0.7931 | 1.487 |
| 0.4000 | 0.4629 | 3.453 97 | 0.079 47 | 0.5842 | 1.293 | 1.0000 | 1.0000 | 1.454 38 | 0.060 81 | 0.7867 | 1.462 |
| 0.5000 | 0.5586 | 3.640 73 | 0.080 36 | 0.5653 | 1.265 | 218.15 K | | | | | |
| 0.6000 | 0.6500 | 3.827 50 | 0.081 47 | 0.5455 | 1.238 | 0.0000 | 0.0000 | 0.460 45 | 0.060 13 | 0.9022 | 2.027 |
| 0.7000 | 0.7387 | 4.015 08 | 0.082 87 | 0.5243 | 1.212 | 0.1000 | 0.1805 | 0.512 69 | 0.059 81 | 0.8960 | 1.982 |
| 0.8000 | 0.8258 | 4.204 24 | 0.084 72 | 0.5013 | 1.185 | 0.2000 | 0.3258 | 0.562 62 | 0.059 49 | 0.8899 | 1.933 |
| 0.9000 | 0.9124 | 4.395 67 | 0.087 23 | 0.4757 | 1.158 | 0.3000 | 0.4463 | 0.610 17 | 0.059 17 | 0.8840 | 1.880 |
| 1.0000 | 1.0000 | 4.589 97 | 0.090 95 | 0.4462 | 1.128 | 0.4000 | 0.5491 | 0.655 52 | 0.058 87 | 0.8784 | 1.827 |
| 263.15 K | | | | | | 0.5000 | 0.6395 | 0.698 95 | 0.058 57 | 0.8729 | 1.774 |
| 0.0000 | 0.0000 | 1.861 50 | 0.070 98 | 0.7364 | 1.544 | 0.6000 | 0.7209 | 0.740 85 | 0.058 29 | 0.8677 | 1.722 |
| 0.1000 | 0.1439 | 2.009 60 | 0.070 98 | 0.7240 | 1.513 | 0.7000 | 0.7961 | 0.781 59 | 0.058 01 | 0.8627 | 1.674 |
| 0.2000 | 0.2703 | 2.154 49 | 0.071 01 | 0.7115 | 1.481 | 0.8000 | 0.8669 | 0.821 55 | 0.057 74 | 0.8578 | 1.629 |
| 0.3000 | 0.3833 | 2.296 33 | 0.071 09 | 0.6988 | 1.450 | 0.9000 | 0.9346 | 0.860 98 | 0.057 48 | 0.8531 | 1.588 |
| 0.4000 | 0.4862 | 2.435 45 | 0.071 21 | 0.6862 | 1.419 | 1.0000 | 1.0000 | 0.900 06 | 0.057 23 | 0.8485 | 1.549 |
| 0.5000 | 0.5815 | 2.572 33 | 0.071 38 | 0.6735 | 1.390 | 203.15 K | | | | | |
| 0.6000 | 0.6712 | 2.707 53 | 0.071 61 | 0.6608 | 1.361 | 0.0000 | 0.0000 | 0.250 63 | 0.057 72 | 0.9369 | 2.246 |
| 0.7000 | 0.7568 | 2.841 70 | 0.071 91 | 0.6480 | 1.334 | 0.1000 | 0.1961 | 0.283 52 | 0.057 36 | 0.9322 | 2.195 |
| 0.8000 | 0.8396 | 2.975 51 | 0.072 29 | 0.6353 | 1.309 | 0.2000 | 0.3480 | 0.314 73 | 0.057 01 | 0.9277 | 2.135 |
| 0.9000 | 0.9205 | 3.109 63 | 0.072 77 | 0.6223 | 1.286 | 0.3000 | 0.4701 | 0.344 16 | 0.056 66 | 0.9233 | 2.070 |
| 1.0000 | 1.0000 | 3.244 71 | 0.073 36 | 0.6091 | 1.265 | 0.4000 | 0.5716 | 0.371 90 | 0.056 31 | 0.9191 | 2.002 |
| 248.15 K | | | | | | 0.5000 | 0.6590 | 0.398 19 | 0.055 98 | 0.9152 | 1.933 |
| 0.0000 | 0.0000 | 1.235 86 | 0.066 47 | 0.8022 | 1.681 | 0.6000 | 0.7367 | 0.423 33 | 0.055 65 | 0.9115 | 1.866 |
| 0.1000 | 0.1548 | 1.344 90 | 0.066 30 | 0.7926 | 1.649 | 0.7000 | 0.8079 | 0.447 64 | 0.055 32 | 0.9079 | 1.803 |
| 0.2000 | 0.2875 | 1.450 98 | 0.066 14 | 0.7829 | 1.614 | 0.8000 | 0.8748 | 0.471 43 | 0.055 00 | 0.9045 | 1.747 |
| 0.3000 | 0.4037 | 1.554 08 | 0.066 01 | 0.7732 | 1.579 | 0.9000 | 0.9386 | 0.494 95 | 0.054 69 | 0.9011 | 1.698 |
| 0.4000 | 0.5073 | 1.654 35 | 0.065 89 | 0.7637 | 1.544 | 1.0000 | 1.0000 | 0.518 34 | 0.054 38 | 0.8978 | 1.658 |
| 0.5000 | 0.6015 | 1.752 13 | 0.065 80 | 0.7543 | 1.509 | 198.15 K | | | | | |
| 0.6000 | 0.6888 | 1.847 84 | 0.065 73 | 0.7451 | 1.476 | 0.0000 | 0.0000 | 0.199 97 | 0.056 99 | 0.9465 | 2.335 |
| 0.7000 | 0.7711 | 1.942 00 | 0.065 69 | 0.7361 | 1.444 | 0.1000 | 0.2022 | 0.227 72 | 0.056 62 | 0.9423 | 2.281 |
| 0.8000 | 0.8498 | 2.035 15 | 0.065 69 | 0.7273 | 1.414 | 0.2000 | 0.3566 | 0.253 99 | 0.056 26 | 0.9382 | 2.217 |
| 0.9000 | 0.9259 | 2.127 87 | 0.065 72 | 0.7186 | 1.388 | 0.3000 | 0.4790 | 0.278 65 | 0.055 90 | 0.9342 | 2.145 |
| 1.0000 | 1.0000 | 2.220 72 | 0.065 78 | 0.7099 | 1.366 | 0.4000 | 0.5798 | 0.301 80 | 0.055 55 | 0.9305 | 2.070 |
| 233.15 K | | | | | | 0.5000 | 0.6660 | 0.323 64 | 0.055 20 | 0.9270 | 1.994 |
| 0.0000 | 0.0000 | 0.779 16 | 0.062 98 | 0.8578 | 1.840 | 0.6000 | 0.7422 | 0.344 45 | 0.054 86 | 0.9237 | 1.920 |
| 0.1000 | 0.1669 | 0.856 49 | 0.062 71 | 0.8500 | 1.802 | 0.7000 | 0.8119 | 0.364 53 | 0.054 52 | 0.9206 | 1.850 |
| 0.2000 | 0.3059 | 0.931 15 | 0.062 44 | 0.8422 | 1.763 | 0.8000 | 0.8773 | 0.384 15 | 0.054 19 | 0.9176 | 1.788 |
| 0.3000 | 0.4245 | 1.003 07 | 0.062 19 | 0.8346 | 1.721 | 0.9000 | 0.9398 | 0.403 51 | 0.053 87 | 0.9147 | 1.733 |
| 0.4000 | 0.5281 | 1.072 37 | 0.061 95 | 0.8272 | 1.678 | 1.0000 | 1.0000 | 0.422 70 | 0.053 55 | 0.9118 | 1.684 |

Table VI. Errors in Relative Volatility Generated by Errors in Correlations

| | x = 0.10 | | x = 0.50 | | x = 0.90 | | x = 0.95 | | error |
|----------|----------|----------|----------|----------|----------|----------|----------|----------|-------|
| | α | Δ | α | Δ | α | Δ | α | Δ | |
| 278.15 K | | | | | | | | | |
| | 1.3792 | | 1.2653 | | 1.1575 | | 1.1431 | | |
| | 1.3800 | 0.0008 | 1.2654 | 0.0001 | 1.1566 | 0.0009 | 1.1419 | 0.0012 | 1 |
| | 1.3819 | 0.0027 | 1.2680 | 0.0027 | 1.1595 | 0.0020 | 1.1449 | 0.0018 | 2 |
| | 1.3810 | 0.0018 | 1.2648 | 0.0005 | 1.1557 | 0.0018 | 1.1414 | 0.0017 | 3 |
| sum | | 0.0053 | | 0.0033 | | 0.0047 | | 0.0047 | |
| 198.15 K | | | | | | | | | |
| | 2.2808 | | 1.9939 | | 1.7335 | | 1.7089 | | |
| | 2.2828 | 0.0020 | 1.9957 | 0.0018 | 1.7348 | 0.0013 | 1.7101 | 0.0012 | 1 |
| | 2.2792 | 0.0016 | 1.9921 | 0.0018 | 1.7320 | 0.0015 | 1.7075 | 0.0014 | 2 |
| | 2.2846 | 0.0038 | 1.9957 | 0.0018 | 1.7275 | 0.0060 | 1.7012 | 0.0077 | 3 |
| sum | | 0.0074 | | 0.0054 | | 0.0088 | | 0.0103 | |

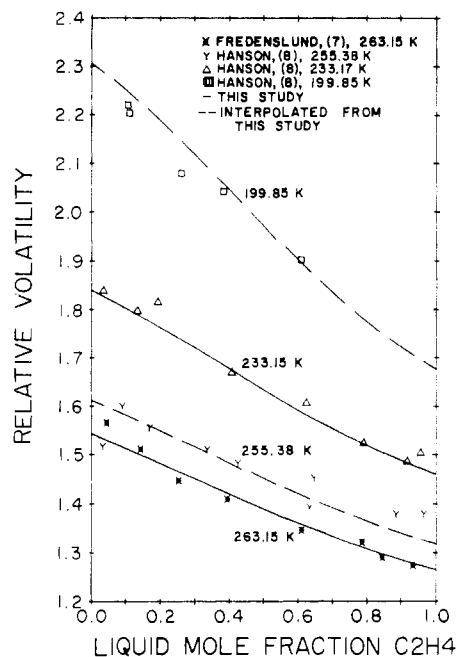

Figure 11. Literature comparison of relative volatilities for ethane-ethylene system.

| | |
|---------------|---|
| P_r | reference pressure in Goodwin equation |
| P_R | Raoult's law pressure |
| P_c | critical pressure |
| R | gas constant |
| T | temperature |
| T_c | critical temperature |
| V | volume, L/mol |
| x | liquid mole fraction, unsubscripted means most volatile component |
| y | vapor mole fraction, unsubscripted means most volatile component |
| z | overall mole fraction of ethylene in sample cell |
| Z | vapor compressibility factor |
| α | relative volatility |
| δ_{ij} | binary interaction parameter |
| ρ | density |
| ϕ_i | fugacity of component i in a mixture |

Subscripts

| | |
|-----|--|
| 1,2 | components in binary system, 1 is most volatile |
| l | liquid |
| o | overall |
| P | constraint on partial derivative to constant pressure |
| v | vapor |
| y | constraint on partial derivative to constant composition |

Superscripts

| | |
|---|--------|
| l | liquid |
| v | vapor |

Literature Cited

- (1) Manley, D. B. Ph.D. Dissertation, The University of Kansas, Lawrence, KS, 1970.
- (2) Manley, D. B.; Swift, G. W. *J. Chem. Eng. Data* **1971**, *16*, 301.
- (3) Walker, S. L. M.S. Thesis, University of Missouri—Rolla, Rolla, MO, 1973.
- (4) Steele, K. M.S. Thesis, University of Missouri—Rolla, Rolla, MO, 1975.
- (5) Steele, K.; Poling, B. E.; Manley, D. B. *J. Chem. Eng. Data* **1976**, *21*, 399.
- (6) Barclay, D. A. Ph.D. Dissertation, University of Missouri—Rolla, Rolla, MO, 1980.
- (7) Fredenslund, A.; Mollerup, J.; Hall, K. *J. Chem. Eng. Data* **1976**, *21*, 301.
- (8) Hanson, G. H.; Hogan, R. J.; Ruehlen, F. N.; Cines, M. R. *Chem. Eng. Prog., Symp. Ser.* **1953**, *49*, 37.
- (9) Gibbs, R. E.; Van Ness, H. C. *Ind. Eng. Chem. Fundam.* **1972**, *11*, 410.
- (10) McCalla, T. R. "Introduction to Numerical Methods and Fortran Programming"; Wiley: New York, 1967.
- (11) Soave, G. *Chem. Eng. Sci.* **1972**, *27*, 1197.
- (12) Hankinson, R. W.; Thomson, G. H. *AIChE J.* **1979**, *25*, 653.
- (13) Douslin, D. R.; Harrison, R. H. *J. Chem. Thermodyn.* **1973**, *5*, 491.
- (14) Douslin, D. R.; Harrison, R. H. *J. Chem. Thermodyn.* **1976**, *8*, 301.
- (15) Ely, J. F.; Kobayashi, R. *J. Chem. Eng. Data* **1978**, *23*, 221.
- (16) Straty, G. C.; Tsumura, R. *J. Res. Natl. Bur. Stand., Sect. A* **1976**, *80*, 35.
- (17) Pal, A. K.; Pope, G. A.; Aral, Y.; Carnahan, N. F.; Kobayshi, R. *J. Chem. Eng. Data* **1976**, *21*, 394.
- (18) American Petroleum Institute, Research Project 44, Selected Values of Properties of Hydrocarbons and Related Compounds, Supplement dated October 1974.
- (19) American Petroleum Institute, Research Project 44, Selected Values of Properties of Hydrocarbons and Related Compounds, Supplement dated April 1977.
- (20) Goodwin, R. D. *J. Res. Natl. Bur. Stand., Sect. A* **1975**, *79*, 71.
- (21) Hastings, J. R.; Levelt Sengers, J. M. H. "Proceedings of the Seventh Symposium on Thermophysical Properties", National Bureau of Standards, Gaithersburg, MD, May 10-12, 1977, pp 794-806.

Received for review April 10, 1981. Accepted October 19, 1981.

Osmotic and Activity Coefficients of Some Sulfamates and Sulfanilates at 298.15 K

Oscar D. Bonner

Department of Chemistry, University of South Carolina, Columbia, South Carolina 29208

Osmotic and activity coefficients are reported for solutions of the sodium and potassium salts of sulfamic and sulfanilic acids and for the parent acid. The data are in agreement with the evidence in the literature that sulfamic acid is a moderately strong acid with an ionization constant which is not too different from that of iodic acid.

Moderately strong acids such as iodic or the trihaloacetic acids are a small and unique group in that, while many acids

are quite weak or quite strong, there are few acids with ionization constants in the range of 10^{-1} – 10 . A recent survey article (1) reminded one that sulfamic and sulfanilic acids exist as zwitterions in solution and suggested that a study of the properties of solutions of these acids and their salts might be of interest. The ionization constant for the equilibrium

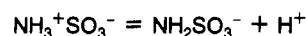

has been reported to be 0.1006 from conductance measure-