

Figure 6. Solubility of  $\text{CH}_4$  at 25 °C: (a) mixtures of NMP with MEA; (b) mixtures of NMP with DEA.

$\text{CH}_4$  is comparatively low in the mixtures of NMP with MEA; furthermore, as the concentration of MEA increases, the solubility of  $\text{CH}_4$  decreases, which is highly favorable since the solubility of both  $\text{CO}_2$  and  $\text{H}_2\text{S}$  varies in the opposite way. Thus, the mixtures of NMP with MEA present good efficiency to remove acid gases and at the same time low selectivity for  $\text{CH}_4$ .

Although the experimental data reported in this work are limited, it is possible to conclude that mixtures composed of a physical and a chemical solvent may be an excellent alternative to the aqueous solutions of alkanolamines for the removal of acid gases from gas streams. In particular the mixtures of NMP with MEA may prove to be rather appropriate.

Registry No.  $\text{CO}_2$ , 124-38-9;  $\text{CH}_4$ , 74-82-8;  $\text{H}_2\text{S}$ , 7783-06-4; NMP, 872-50-4; MEA, 141-43-5; DEA, 111-42-2; PC, 108-32-7.

#### Literature Cited

- (1) Ranke, G. *Chem. Econ. Eng. Rev.* **1973**, *4*, 25.
- (2) Hochgesand, G. *Ind. Eng. Chem.* **1970**, *62*, 37.
- (3) Kohi, A. L.; Buckingham, P. A. *Pet. Refiner* **1980**, *39*, 193.
- (4) Buckingham, P. A. *Hydrocarbon Process*, **1984**, *43*, 113.
- (5) Sweeney, J. L.; Brooks, G. E. "Proceedings of the 20th Gas Conditioning Conference, University of Oklahoma, Norman, OK, 1970"; paper H-1.
- (6) Deal, C. H.; Dunn, C. L.; Hill, E. J.; Papadopoulos, M. N.; Zarker, K. E. "Proceedings of the 6th World Petroleum Congress, Section IV, Frankfurt, 1963".
- (7) Dunn, C. L.; Freitas, E. R.; Goodenbour, J. W.; Henderson, H. T.; Papadopoulos, M. N. *Hydrocarbon Process*, **1984**, *43*, 150.
- (8) Murrieta-Guevara, F.; Trejo-Rodríguez, A. *J. Chem. Eng. Data* **1984**, *29*, 204.
- (9) Rivas, O. R.; Prausnitz, J. M. *AIChE J.* **1979**, *25*, 975.
- (10) Rivas, O. R. Ph.D. Dissertation, University of California, Berkeley, CA, 1978.

Received for review September 6, 1983. Revised manuscript received March 7, 1984. Accepted April 7, 1984.

## Molar Volumes of Binary Solutions of Nitrobenzene in Halogenated and Nonhalogenated Solvents

Marcia Tapper, Carolyn S. Birnbaum, R. Waksak, and Vojtech Fried\*

Department of Chemistry of the City University of New York, Brooklyn College, Brooklyn, New York 11210

The molar volume as a function of composition is measured at  $25.00 \pm 0.01$  °C for the following systems: toluene,  $\alpha, \alpha, \alpha$ -trichlorotoluene,  $\alpha, \alpha, \alpha$ -trifluorotoluene, cumene, *tert*-butylbenzene, ethanol, 2,2,2-trichloroethanol, 2,2,2-trifluoroethanol, acetic acid, trifluoroacetic acid, acetic anhydride, and trifluoroacetic anhydride with nitrobenzene as the second component. Preliminary study shows no obvious correlation between  $V^E$  and the molecular structure of the various solution constituents.

#### Introduction

The work presented here is a continuation of our effort to establish a data bank for volumetric behavior of liquid solutions. The data will be employed in deriving and testing semiempirical methods for predicting the volumetric behavior of liquid solutions from the volumetric behavior of the pure solution constituents. In the absence of rigorous thermodynamic methods, such semiempirical approaches are of great importance in predicting the volumetric behavior of liquid solutions. Such theories are

**Table I. Densities of the Various Systems as a Function of Mole Fraction at 25 ± 0.1 °C**

$x_1$	$d/(g\text{ cm}^{-3})$	$x_1$	$d/(g\text{ cm}^{-3})$
<b><math>\alpha,\alpha,\alpha</math>-Trichlorotoluene (1) + NB (2)</b>			
0.0000	1.198 23	0.0000	1.198 32
0.0563	1.210 98	0.0615	1.172 92
0.1053	1.222 05	0.1049	1.155 83
0.2040	1.242 72	0.1599	1.134 19
0.3683	1.274 25	0.2079	1.115 84
0.4164	1.282 82	0.2501	1.100 12
0.5390	1.303 51	0.3846	1.051 81
0.6037	1.314 30	0.4403	1.032 63
0.8017	1.342 33	0.4957	1.013 98
0.9081	1.356 27	0.5594	0.993 01
1.0000	1.367 48	0.6296	0.970 63
		0.7721	0.927 14
		0.8434	0.906 47
		0.9143	0.886 23
		1.0000	0.862 36
<b>Acetic Acid (1) + NB (2)</b>			
0.0000	1.198 15		
0.1147	1.187 56		
0.2174	1.177 20		
0.2944	1.168 86		
0.4526	1.149 13		
0.5227	1.139 37		
0.6398	1.120 87		
0.6938	1.111 71		
0.7935	1.092 81		
0.8391	1.083 50		
0.9258	1.063 55		
0.9552	1.056 11		
1.0000	1.043 78		
<b>Trifluoroacetic Anhydride (1) + NB (2)</b>			
0.0000	1.198 31		
0.0435	1.217 90		
0.0945	1.240 19		
0.2486	1.303 11		
0.3102	1.325 89		
0.4293	1.366 10		
0.4723	1.379 69		
0.6066	1.417 41		
0.6830	1.436 50		
0.8180	1.465 19		
0.9005	1.479 89		
1.0000	1.494 70		
<b>Acetic Anhydride (1) + NB (2)</b>			
0.0000	1.198 27		
0.0809	1.188 98		
0.1512	1.180 82		
0.1992	1.175 28		
0.3278	1.159 98		
0.4068	1.150 51		
0.5256	1.135 94		
0.5724	1.130 02		
0.6778	1.116 76		
0.7542	1.106 91		
0.8500	1.094 46		
0.9213	1.085 16		
1.0000	1.074 75		
<b>Ethanol (1) + NB (2)</b>			
0.0000	1.198 21		
0.0988	1.174 65		
0.1951	1.149 90		
0.2908	1.122 66		
0.4426	1.073 92		
0.5117	1.048 81		
0.6328	0.999 34		
0.6887	0.973 80		
0.7882	0.923 16		
0.8343	0.897 10		
0.9162	0.845 86		
0.9545	0.819 50		
1.0000	0.785 41		
<b>2,2,2-Trifluoroethanol (1) + NB (2)</b>			
0.0000	1.198 31		
0.1037	1.210 62		
0.1912	1.222 23		
0.3329	1.242 66		
0.3915	1.251 86		
0.4702	1.264 54		
0.5894	1.285 98		
0.6496	1.297 88		
0.7032	1.308 62		
0.7541	1.319 47		
0.8087	1.331 75		
0.9082	1.356 23		
0.9502	1.367 56		
1.0000	1.382 41		

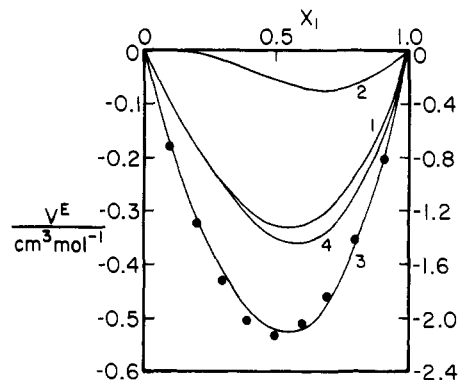
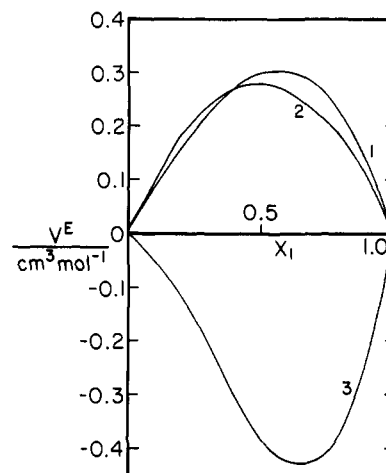
**Figure 1.** Excess volumes as a function of composition at 25 ± 0.01 °C: 1, toluene (1) and nitrobenzene (2); 2,  $\alpha,\alpha,\alpha$ -trichlorotoluene (1) and nitrobenzene (2); 3,  $\alpha,\alpha,\alpha$ -trifluorotoluene (1) and nitrobenzene (2) (scale to the left) and *tert*-butylbenzene (1) and nitrobenzene (2) (solid circles, scale to the right); 4, cumene (1) and nitrobenzene (2).**Figure 2.** Excess volumes as a function of composition at 25 ± 0.01 °C: 1,  $\alpha,\alpha,\alpha$ -trifluoroethanol (1) and nitrobenzene (2); 2,  $\alpha,\alpha,\alpha$ -trichloroethanol (1) and nitrobenzene (2); 3, ethanol (1) and nitrobenzene (2).

already available for predicting excess Gibbs free energies (1–4); the literature is, however, very meager when it comes to methods predicting the volume of mixing.

In our previous work (5, 6), we reported volumetric data for systems exhibiting weak charge-transfer interactions. In this work, we report volumetric data for binary solutions containing nitrobenzene (NB) as one component and halogenated or similar nonhalogenated compounds as the other component. Toluene,  $\alpha,\alpha,\alpha$ -trifluorotoluene,  $\alpha,\alpha,\alpha$ -trichlorotoluene, cumene, *tert*-butylbenzene, ethanol, 2,2,2-trifluoroethanol, 2,2,2-trichloroethanol, acetic acid, trifluoroacetic acid, acetic anhydride, and trifluoroacetic anhydride were used as the other components.

### Experimental Section

Fisher and Aldrich commercial chemicals of highest purity were further purified by standard procedures, such as distillation and crystallization. With the exception of the nitrobenzene, all the aromatic compounds and alcohols used in the investigation contained no trace impurities as indicated by gas-liquid chromatography. The densities, refractive indices, and normal boiling points of these compounds were in complete agreement with the literature values (7). The nitrobenzene has shown some small, but definite, variation in its physical properties with time. For this reason, freshly distilled nitrobenzene was used in the investigation. The acids and their anhydrides used in the investigation were of better than 99.8% purity and were used without further purification.

Table II. Parameters of Eq 2 Expressing the Dependence of the Molar Volume on the Mole Fraction at 25.00 ± 0.01 °C

system	$b_0$	$b_1$	$b_2$	$b_3$
$\alpha,\alpha,\alpha$ -trichlorotoluene (1) + NB (2)	102.748	40.315	-0.7727	0.6636
acetic acid (1) + NB (2)	102.751	-45.116	-0.1979	0.0797
trifluoroacetic acid (1) + NB (2)	102.711	-25.243	-3.0839	2.7417
2,2,2-trichloroethanol (1) + NB (2)	102.758	-5.2010	-1.3510	0.1502
2,2,2-trifluoroethanol (1) + NB (2)	102.757	-29.470	-0.2681	-0.6215
<i>tert</i> -butylbenzene (1) + NB (2)	102.734	45.066	6.6115	1.2162
trifluoroacetic anhydride (1) + NB (2)	102.756	32.687	2.2671	2.8100
acetic anhydride (1) + NB (2)	102.741	-7.7943	0.0496	
ethanol (1) + NB (2)	102.731	-44.303	-2.4090	2.6000
toluene (1) + NB (2) <sup>a</sup>	102.731	3.1129	0.4169	0.5852
cumene (1) + NB (2) <sup>a</sup>	102.719	36.361	-0.0904	0.9898
$\alpha,\alpha,\alpha$ -trifluorotoluene (1) + NB (2)	102.735	19.129	1.2251	0.5794

<sup>a</sup>Data taken from ref 3.

Table III. Comparison of Some Characteristic Properties of the Different Systems

component	$V_m/$ ( $\text{cm}^3 \text{mol}^{-1}$ )	$M/$ ( $\text{g mol}^{-1}$ )	$V_{m,1}/$ $V_{m,2}$	$(V^E/(x_1x_2))_{x_1=x_2=0.5}/$ ( $\text{cm}^3 \text{mol}^{-1}$ )
toluene	106.846	92.139	1.040	-1.295
$\alpha,\alpha,\alpha$ -trifluorotoluene	123.669	114.023	1.203	-2.094
$\alpha,\alpha,\alpha$ -trichlorotoluene	142.954	195.475	1.391	-0.222
cumene	139.979	120.193	1.362	-1.394
<i>tert</i> -butylbenzene	155.628	134.223	1.515	-8.436
ethanol	58.619	46.069	0.571	-1.491
2,2,2-trifluoroethanol	72.397	100.040	0.705	1.300
2,2,2-trichloroethanol	96.356	149.404	0.938	1.126
acetic acid	57.517	60.053	0.560	0.088
2,2,2-trifluoroacetic acid	77.126	114.024	0.751	-1.029
acetic anhydride	94.997	102.089	0.925	-0.050
2,2,2-trifluoroacetic anhydride	140.520	210.032	1.370	-6.482
nitrobenzene	102.739	123.110		

The pycnometric method, described previously (5), was employed for the density measurement. Considering all the inconsistencies involved in the measurement (preparing the solution and filling the pycnometers), we estimate the overall error in the density measurement to be about  $\pm 5 \times 10^{-5} \text{ g cm}^{-3}$ . The temperature of the heat bath was kept constant at  $25 \pm 0.01$  °C.

## Results and Discussion

The densities of the various systems are listed in Table I. The molar volumes of the solutions,  $V_m$ , evaluated from the measured densities,  $d$ , by using the formula

$$V_m = (x_1M_1 + x_2M_2)/d \quad (1)$$

where  $x_i$  and  $M_i$  are the mole fractions and molecular masses of the solution constituents, were fitted by a least-squares method to a polynomial of the form

$$V_m = \sum_{i=0}^l b x_1^i \quad (2)$$

The number of coefficients necessary to obtain the best fit was chosen so that the deviations of the experimental molar volumes from the correlated ones were within the limits of experimental error ( $\pm 0.005 \text{ cm}^3 \text{mol}^{-1}$ ). With the exception of the acetic anhydride + nitrobenzene system that required three parameters only, all the other systems required four parameters to obtain such accuracy. The obtained parameters are summarized in Table II. The slight fluctuation in the molar volume of pure nitrobenzene ( $V_{m,2} = b_0$ ) is explained by the fact that, for each system, a freshly distilled sample was used. It was practically impossible to obtain samples of nitrobenzene exactly of the same purity. The average value of  $b_0 = 102.739 \text{ cm}^3 \text{mol}^{-1}$  is, however, very close to the literature value (5).

The excess volume per mole of solution was evaluated from the formula

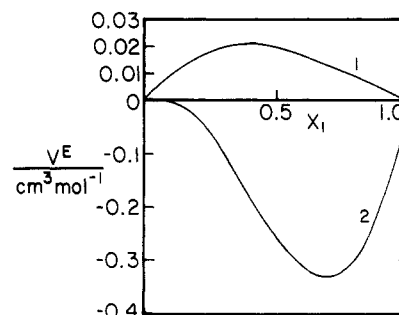

Figure 3. Excess volumes as a function of composition at  $25 \pm 0.01$  °C: 1, acetic acid (1) and nitrobenzene (2) (scale above zero); 2, trifluoroacetic acid (1) and nitrobenzene (2).

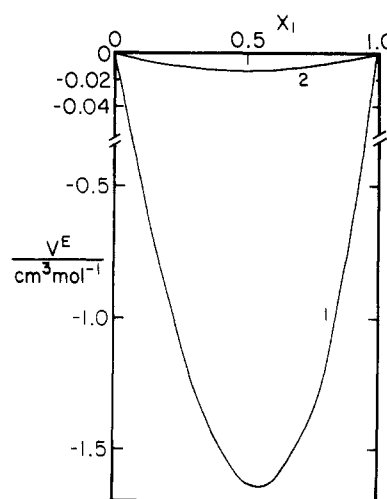

Figure 4. Excess volumes as a function of composition at  $25 \pm 0.01$  °C: 1, trifluoroacetic anhydride (1) and nitrobenzene (2); 2, acetic anhydride (1) and nitrobenzene (2) (upper scale).

$$V^E = V_m - x_1 V_{m,1} - x_2 V_{m,2} = x_1 x_2 [(-b_2 - \frac{3}{2}b_3) - (b_3/2)(x_1 - x_2)] \quad (3)$$

where  $b_2$  and  $b_3$  are the parameters listed in Table II. The obtained excess volumes as a function of composition are plotted in Figures 1-4. The values of  $V^E/(x_1 x_2)$  at  $x_1 = x_2 = 0.5$  together with the volume ratio,  $V_1/V_2$ , and the molecular masses of the individual components are listed in Table III.

The 2,2,2-trifluoroethanol and 2,2,2-trichloroethanol systems exhibit roughly equal positive  $V^E$  values and the ethanol system exhibits negative  $V^E$  values. From the two systems containing the acids, the trifluoroacetic acid system shows negative  $V^E$  values and the trichloroacetic acid system exhibits small positive  $V^E$  values. From the two anhydride systems, the trifluoroacetic anhydride exhibits large negative  $V^E$  values and the trichloroacetic anhydride shows small negative  $V^E$  values only. The data on the substituted-toluene systems indicate (at least qualitatively) that the steric effect in combination with the electron charge-transfer interactions determines the  $V^E$  values of the systems.  $V^E$  is more negative for the *tert*-butylbenzene system than it is for the cumene system and  $V^E$  for the cumene system is more negative than it is for the toluene system.

An interpretation of the  $V^E$  values in terms of the molecular structure of the solution constituents will be presented in another publication.

**Registry No.** NB, 98-95-3; toluene, 108-88-3;  $\alpha,\alpha,\alpha$ -trichlorotoluene, 98-07-7;  $\alpha,\alpha,\alpha$ -trifluorotoluene, 98-08-8; cumene, 98-82-8; *tert*-butylbenzene, 98-06-6; ethanol, 64-17-5; 2,2,2-trichloroethanol, 115-20-8; 2,2,2-trifluoroethanol, 75-89-8; acetic acid, 64-19-7; trifluoroacetic acid, 76-05-1; acetic anhydride, 106-24-7; trifluoroacetic anhydride, 407-25-0.

#### Literature Cited

- (1) Fredenslund, Aa.; Gmehling, J.; Rasmussen, P. "Vapor-Liquid Equilibrium Using UNIFAC"; Elsevier: Amsterdam, 1977.
- (2) Sørensen, J. M.; Magnussen, T.; Rasmussen, P.; Fredenslund, Aa. *Fluid Phase Equilib.* **1979**, *2*, 297.
- (3) Sørensen, J. M.; Magnussen, T.; Rasmussen, P.; Fredenslund, Aa. *Fluid Phase Equilib.* **1979**, *3*, 47.
- (4) Sørensen, J. M.; Magnussen, T.; Rasmussen, P.; Fredenslund, Aa. *Fluid Phase Equilib.* **1980**, *4*, 151.
- (5) Miller, L. P.; Wachter, H. N.; Fried, V. *J. Chem. Eng. Data* **1975**, *20*, 417.
- (6) Fried, V.; Miller, L. P.; Wachter, H. N. *Bull. Chem. Soc. Jpn.* **1977**, *50*, 497.
- (7) Timmermans, J. "Physicochemical Constants of Pure Organic Compounds"; Elsevier: New York, 1950.

Received for review October 13, 1983. Accepted May 16, 1984. This work was supported by CUNY-FRAP Grant No. 6-89358.

## Isobaric Vapor-Liquid Equilibria for the Ternary System Acetone-Ethyl Acetate-Ethanol

Renzo Carta, Stella Dernini,\* and Paolo Sanna

*Istituto di Chimica Applicata e Metallurgia, Facoltà di Ingegneria, Università di Cagliari, Italy*

VLE data at 760 mmHg for the ternary system acetone-ethyl acetate-ethanol have been experimentally obtained. The measurements were conducted in a modified Gillespie-type, two-phase recirculation still. The VLE data for the binary system acetone-ethanol were also measured and compared with some literature values to check the modified still. The activity coefficients of the binary systems were correlated according to the Wilson, NRTL, and UNIQUAC equations and the binary parameters obtained were employed to predict the ternary VLE. These results, together with the values predicted by the UNIFAC method, are compared with experimental points, showing a good agreement.

#### Introduction

Vapor-liquid equilibria data provide useful information both theoretical and of interest in process design. While numerous experimental data are readily available for VLE of binary system, this is not so for multicomponent systems. This paper aims at increasing the number of existing experimental data and

at verifying the possibility of predicting the behavior of ternary mixtures from the binary data. To this end the Wilson (1), NRTL (2), and UNIQUAC (3) equations were utilized, due to their great flexibility in the representation of VLE. Furthermore, the reliability of the UNIFAC method (4) in the quantitative estimation of ternary system phase equilibria was also tested.

The system examined is interesting since the binary ethyl acetate-ethanol system shows a minimum boiling point azeotrope. Hence, it is useful to establish whether the ternary system also presents an azeotrope or not.

#### Experimental Section

The isobaric measurements of VLE were carried out in a modified Gillespie-type still (5). The still was further modified, as shown in Figure 1, in order to improve the recirculation of condensate and liquid. The modified still was tested by measuring VLE data for the binary system acetone-ethanol, extensively reported in the literature (6-8). Figure 2 illustrates the good agreement between experimental points and data retrieved from the literature and confirms the reliability of the still.

The analyses were performed with a Perkin-Elmer gas chromatograph (3M column packed with Carbowax 20 M, +2%