

Literature Cited

- (1) Basdevant, J. L., *Fortschr. Phys.*, **20**, 283 (1972).
- (2) Douslin, D. R., Harrison, R. H., *J. Chem. Thermodyn.*, **5**, 491 (1973).
- (3) Fletcher, R., Powell, M. J. D., *Comput. J.*, **6**, 163 (1963).
- (4) Genz, A., in "Padé Approximants", Graves-Morris, P. R., Ed., Institute of Physics, London, 1973, p 112.
- (5) Ma, S. K., "Modern Theory of Critical Phenomena", W. A. Benjamin, Reading, Mass., 1976 pp 24, 25.
- (6) Prausnitz, J. M., Chueh, P. L., "Computer Calculations for High-Pressure Vapor-Liquid Equilibria", Prentice-Hall, Englewood Cliffs, N.J., 1968, Appendix B and p 223.
- (7) "Selected Values of Properties of Hydrocarbons and Related Compounds", API Research Project 44, Thermodynamics Research Center, Department of Chemistry, Texas A&M University, 1971.
- (8) Stanley, H. E., "Introduction to Phase Transitions and Critical Phenomena", Oxford University Press, London, 1971, pp 158-163.

Received for review November 28, 1978. Accepted March 12, 1979.

Surface Tensions of Binary Liquid Mixtures of Some Polar and Nonpolar Liquids with Dimethyl Sulfoxide (Me₂SO)

D. K. Agarwal,* Ram Gopal, and Sushma Agarwal

Chemistry Department, Lucknow University, Lucknow, India

The surface tensions of binary liquid mixtures of dimethyl sulfoxide with chloroform, carbon tetrachloride, benzene, toluene, chlorobenzene, bromobenzene, and nitrobenzene have been measured at 30, 40, and 50 °C with an improved capillary-rise method. The excess surface tensions at different concentrations of these mixtures were calculated at equimolar concentrations, from surface tension data. Except for the dimethyl sulfoxide + nitrobenzene system, all other mixtures have negative excess surface tensions which indicate a strong attractive interaction in these systems. For the dimethyl sulfoxide + nitrobenzene system, excess surface tensions are positive.

Introduction

Molecular interactions in binary liquid mixtures have been studied by many workers using surface tension data (4, 6, 8). Me₂SO is a solvent of recent interest because it is highly polar ($\mu = 4.3$ D) (2) which should promote strong dipole-dipole interaction. It is a solvent of medium dielectric constant ($\epsilon_{20} = 48.9$) (2) and has no significant hydrogen bonding (5). It is therefore a little surprising that only a few studies on surface tensions of binary liquid mixtures involving the Me₂SO as one of the two components have been reported (1, 9). Clever and Sneed (1) studied the surface tensions of the mixtures of acetone and Me₂SO. These studies appear to be sketchy and a detailed investigation appears very desirable. It seems, therefore, fruitful to measure surface tensions of mixtures of some polar and nonpolar liquids such as chloroform, carbon tetrachloride, benzene, toluene, chlorobenzene, bromobenzene, and nitrobenzene with Me₂SO at 30, 40, and 50 °C.

Experimental Section

Me₂SO (Fluka purum) was dried over freshly ignited quicklime and was repeatedly distilled at reduced pressure until the electrical conductivity of the purified samples was reduced to $10^{-7} \Omega^{-1}$. The purified sample was kept in a drybox until used.

Chloroform, carbon tetrachloride, benzene, toluene, chlorobenzene, bromobenzene and nitrobenzene were purified as per standard procedures (11). The purity of the purified samples was checked by measuring densities, which were found to agree closely with the corresponding values given in the literature (10).

The solutions were made on a weight-to-weight ratio. Surface tensions of binary mixtures were measured with the help of an improved differential capillary-rise instrument shown in Figure

Table I. Density and Surface Tensions of Me₂SO at Various Temperatures

temp, °C	density, g/mL		surface tension, dyn/cm	
	exptl	lit. (1)	exptl	lit. (1)
30	1.0914	1.0913	42.41	42.41
40	1.0816	1.0816	41.17	41.17
50	1.0723	1.0721	40.05	40.05

1. Two uniform-bore Pyrex glass capillaries of considerable different radii were fixed in a standard joint, Pyrex glass cell (specially designed for this purpose), which held the binary mixture. Uniformity of the bore of the capillary was checked by measuring the length and weight of the mercury thread in different parts of the capillary. The glass cell was filled with the binary mixture and calibrated capillaries were fixed at its mouth and the whole setup was placed in a thermostat running at the desired temperature. The variation in the temperature of the thermostat was ± 0.01 in the lower and ± 0.02 in the higher temperature range. The rise in the height of the liquid column in the capillaries was measured with a cathetometer (least count = 0.001 cm). The angle of contact of binary mixture and glass was taken as zero. Densities of the mixtures were measured using a calibrated dilatometer. A precaution taken to keep the solutions and solvent free from moisture as much as possible was to pass purified dry nitrogen through the empty part of the cell from time to time. The difference in the height of the liquids in two capillaries was noted and the surface tensions were calculated using the formula

$$\gamma'/\gamma = (\Delta h'/\Delta h)(\rho'/\rho)$$

where γ' is the surface tension of the binary mixtures of density ρ' and giving difference in height $\Delta h'$; γ , ρ , and Δh are the corresponding values for the Me₂SO (used as a reference liquid).

Results

Accuracy of the measurements was checked by determining densities and surface tensions of Me₂SO at different temperatures. These values are compared with the literature values in Table I and are found to be in good agreement.

The surface tensions of binary liquid mixtures at 30, 40, and 50 °C are given in Table II.

Discussion

(1) *Variation of Surface Tensions with Mole Fraction.* From the data given in Table II, γ' vs. x_A curves were drawn. Those plots only for the dimethyl sulfoxide + carbon tetrachloride and

Table II. Surface Tensions of Binary Liquid Mixtures at Different Temperatures

x_A	γ' , dyn/cm			x_A	γ' , dyn/cm		
	30 °C	40 °C	50 °C		30 °C	40 °C	50 °C
$x_A(\text{CHCl}_3 + (1-x_A)\text{Me}_2\text{SO})$				$x_A(\text{CCl}_4 + (1-x_A)\text{Me}_2\text{SO})$			
0.0000	42.41	41.17	40.05	0.0000	42.41	41.17	40.05
0.1784	38.19	36.79	35.21	0.2750	34.41	33.07	32.25
0.3021	35.37	34.32	32.68	0.3146	33.43	32.23	31.30
0.4262	33.06	32.24	30.70	0.3992	31.60	30.51	29.72
0.4996	32.57	31.03	29.35	0.4615	30.05	29.22	28.53
0.5748	30.52	29.16	28.01	0.5243	28.73	28.53	27.74
0.7003	28.71	27.63	26.13	0.6835	27.81	26.73	25.67
1.0000	25.83	24.42	23.03	1.0000	25.32	24.18	22.75
$x_A(\text{C}_6\text{H}_6 + (1-x_A)\text{Me}_2\text{SO})$				$x_A(\text{C}_6\text{H}_5\text{CH}_3 + (1-x_A)\text{Me}_2\text{SO})$			
0.0000	42.41	41.17	40.05	0.0000	42.41	41.17	40.05
0.1896	38.63	37.59	36.01	0.1643	39.28	38.13	36.69
0.3785	35.23	33.82	32.28	0.2241	38.08	36.99	35.33
0.4247	34.46	32.70	31.35	0.3418	36.21	34.87	33.62
0.5743	31.89	30.26	28.84	0.4125	35.18	33.73	32.08
0.6359	30.59	29.65	28.17	0.5249	33.29	32.18	30.55
0.7642	29.14	27.74	26.22	0.6918	30.97	29.66	28.15
1.0000	27.49	26.14	24.89	1.0000	27.32	26.15	24.93
$x_A(\text{C}_6\text{H}_5\text{Cl} + (1-x_A)\text{Me}_2\text{SO})$				$x_A(\text{C}_6\text{H}_5\text{Br} + (1-x_A)\text{Me}_2\text{SO})$			
0.0000	42.41	41.17	40.05	0.0000	42.41	41.17	40.05
0.0921	41.18	40.06	38.92	0.2398	40.06	39.02	38.15
0.1543	40.63	39.42	38.18	0.2978	39.63	38.51	37.63
0.2609	39.46	38.48	37.04	0.3426	39.24	38.01	37.62
0.4268	37.82	36.39	35.31	0.4472	39.48	37.32	36.44
0.5179	36.43	35.51	34.23	0.5831	37.51	36.28	35.39
0.6418	35.31	33.96	33.11	0.6413	37.02	35.61	35.21
1.0000	31.98	30.72	29.58	1.0000	35.09	34.24	32.76
$x_A(\text{C}_6\text{H}_5\text{NO}_2 + (1-x_A)\text{Me}_2\text{SO})$							
0.0000	42.41	41.17	40.05	0.4118	42.81	41.61	40.61
0.0664	42.52	41.22	40.20	0.4573	42.90	41.61	40.61
0.1911	42.66	41.50	40.29	0.6428	42.06	41.78	40.78
0.3225	42.88	41.51	40.53	1.0000	43.08	41.92	40.90

dimethyl sulfoxide + nitrobenzene mixtures are given in Figure 2. The curves for other mixtures were almost similar to those for the $\text{Me}_2\text{SO} + \text{CCl}_4$ mixture and therefore were omitted. For all the mixtures, except dimethyl sulfoxide + nitrobenzene, surface tensions deviate negatively from that expected from mixture law. This may be due to the enrichment of the surface with the component of lower surface tension.

(ii) *Variation of Excess Surface Tensions with Mole Fraction.*

From the values of surface tensions (γ'), excess surface tensions for various mixtures at different concentrations were obtained from the formula

$$\gamma^E = \gamma' - (x_A\gamma_A + x_B\gamma_B)$$

where γ' is the surface tension of the mixture, γ_A and γ_B are

Table III. Excess Surface Tensions for Various Mixtures of Me_2SO (B) with Different Liquids (A)

system	temp, °C	γ^E at mole fractions (x_A)						
		0.2	0.3	0.4	0.5	0.6	0.7	0.8
$\text{Me}_2\text{SO} + \text{CHCl}_3$	30	-1.39	-2.03	-2.47	-2.52	-2.41	-2.17	-1.64
	40	-1.31	-1.84	-1.62	-2.17	-2.12	-1.84	-1.47
$\text{Me}_2\text{SO} + \text{CCl}_4$	30	-2.792	-3.483	-3.974	-3.765	-3.456	-2.747	-1.838
	40	-2.772	-3.473	-3.674	-3.875	-3.576	-2.977	-2.078
$\text{Me}_2\text{SO} + \text{C}_6\text{H}_6$	30	-1.080	-1.434	-1.642	-1.950	-1.840	-1.766	-1.474
	40	-1.164	-1.661	-1.858	-2.155	-2.172	-2.149	-1.646
$\text{Me}_2\text{SO} + \text{C}_6\text{H}_5\text{CH}_3$	30	-0.792	-1.083	-1.274	-1.365	-1.256	-1.047	-0.838
	40	-0.666	-0.964	-1.162	-1.160	-1.058	-0.956	-0.654
$\text{Me}_2\text{SO} + \text{C}_6\text{H}_5\text{Cl}$	30	-0.204	-0.271	-0.316	-0.345	-0.352	-0.356	-0.316
	40	-0.080	-0.335	-0.240	-0.395	-0.500	-0.554	-0.510
$\text{Me}_2\text{SO} + \text{C}_6\text{H}_5\text{Br}$	30	-0.446	-0.614	-0.732	-0.734	-0.868	-0.586	-0.404
	40	-0.484	-0.591	-0.798	-0.805	-0.712	-0.619	-0.526
$\text{Me}_2\text{SO} + \text{C}_6\text{H}_5\text{NO}_2$	30	+0.156	+0.189	+0.172	+0.155	+0.138	+0.111	+0.054
	40	+0.080	+0.105	+0.119	+0.135	+0.090	+0.095	+0.040

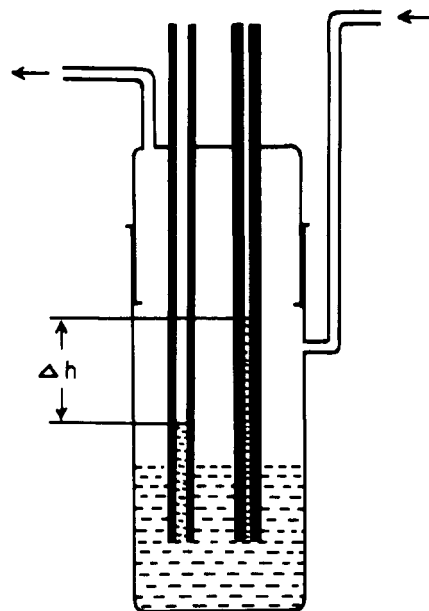
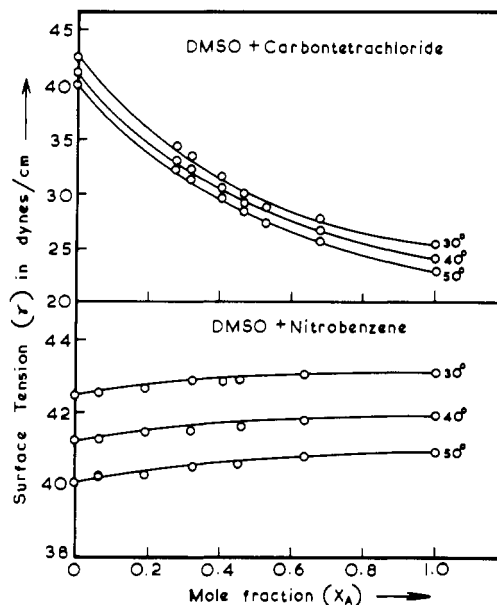

Figure 1. The improved capillary-rise apparatus.

Figure 2. Plot of γ vs. x_A for dimethyl sulfoxide + carbon tetrachloride and dimethyl sulfoxide + nitrobenzene at different temperatures.

the surface tensions of pure components A and B, and x_A and x_B are the bulk mole fractions of the two components, respectively. The values of excess surface tensions (γ^E) for

various mixtures thus obtained are given in Table III at 30 and 40 °C.

It may be noted from Table III that except for the dimethyl sulfoxide + nitrobenzene system, all other mixtures have negative excess surface tensions at all concentrations, i.e., $\gamma^E < 0$. The negative excess volume of mixing values, i.e., $V_m^E < 0$ have already been reported by us (3). These results would suggest the presence of specific interactions in all these mixtures. A somewhat similar type of conclusion was drawn by Nigam and Dhillon (7) for some binary mixtures.

Acknowledgment

Authors are grateful to Professor S. S. Tewari, Head of Lucknow University Chemistry Department, for valuable suggestions and providing laboratory facilities. We are also indebted to the society of Sigma Xi of America for help in importing some chemicals from abroad.

Literature Cited

- (1) Clever, H. L., Sneed, C. C., *J. Phys. Chem.*, **67**, 918 (1963).
- (2) "Dimethylsulphoxide Technical Bulletin", Crown Zellerbach Corp., Chemical Products Division, Camas, Wash., 1966, p 14.
- (3) Gopal, R., Agarwal, S., Agarwal, D. K., *J. Chem. Thermodyn.*, **6**, 801 (1976).
- (4) Jain, D. V. S., Singh, S., *Indian J. Chem.*, **12**, 714 (1974).
- (5) Kinsinger, J. B., Tannabill, M. M., Greenberg, M. S., Popov, A. I., *J. Phys. Chem.*, **77**, 2444 (1973).
- (6) Nigam, R. K., Maini, N. N., *Indian J. Chem.*, **9**, 855 (1971).
- (7) Nigam, R. K., Dhillon, M. S., *J. Chem. Thermodyn.*, **3**, 819 (1971).
- (8) Suri, S. K., Ramakrishna, V., *J. Phys. Chem.*, **72**, 3073 (1968).
- (9) Staira, R. A., Rispin, W. T., *Can. J. Chem.*, **48**, 2755 (1970).
- (10) Timmermans, J., "Physico-Chemical Constants of Pure Organic Compounds", Elsevier Publishing, New York, 1970.
- (11) Vogel, A. I., "Practical Organic Chemistry", Longman Group Ltd., London, 1971, pp 170-176.

Received for review September 8, 1977. Accepted January 16, 1979. S.A. is obliged to the C.S.I.R. India for financial support.

Volumetric Properties of Molten Hydrated Salts. 2. Zinc Nitrate Hexahydrate + Alkali Metal Nitrates

Ramesh C. Sharma, Kavita Bhatia, and Harish C. Gaur*

Department of Chemistry, University of Delhi, Delhi-110007, India

Densities of molten $Zn(NO_3)_2 \cdot 6H_2O + MNO_3$ (M = Li, Na, K, Rb, Cs) systems have been measured by using a manometric densitometer at temperatures ranging between 288.2 and 363.2 K. Temperature dependence of densities and equivalent volumes was found to be linear. Equivalent volumes of all systems except those containing lithium nitrate were additive; small positive deviations in the latter have been considered to arise due to preferential hydration of Li^+ ions.

Mass and transport behavior of molten hydrated salts containing 4-6 mol of water/mol of the electrolyte have been explained (1-7, 9-14, 17, 18) by assuming that the water of hydration is almost wholly associated with the cation, forming weak field species of the type $M(H_2O)_n^{2+}$. They have low liquidus temperature, and some of their solutions in the presence of alkali metal ions show appreciable tendency to supercool. In view of the recent interest in them and in continuation of our studies on these systems (3, 17, 18), the densities of molten $Zn(NO_3)_2 \cdot 6H_2O + MNO_3$ systems, where M = Li, Na, K, Rb, and Cs, are presented in this paper.

Experimental Section

An approximately 5-kg batch of hydrated zinc nitrate, LR (BDH) grade, was melted and filtered through a sintered glass tube (porosity G-3) into several airtight bottles. Water content of a sample, determined by volumetric titration by using EDTA, was found to be 6.02 ± 0.01 mol/mol of zinc nitrate. The alkali metal nitrates, AnalaR (BDH) or equivalent purity, were desiccated to constant mass at 400-450 K. Calculated amounts of these were added to bottles containing hydrated zinc nitrate which were matured at about 40 °C for about 1 h before use; loss of water

content during this was found to be negligible.

The densitometer, experimental details of measurements, and the precision attained have been discussed earlier (16).

Results and Discussion

Density (ρ) data of $Zn(NO_3)_2 \cdot 6H_2O + MNO_3$ (M = Li, Na, K, Rb, Cs) mixtures were obtained at an interval of 5 K in the temperature range 288.2-363.2 K. Equivalent volumes (V_e) were calculated by using the mass of mixture containing 1 mol of NO_3^- ions (cf. 15, 17, 18). Variation of ρ and V_e with temperature was found to be linear; data were least-squares fitted into an equation of type

$$(\rho \cdot V_e) = A \pm B(T - 300) \quad (1)$$

Coefficients A and B which were characteristic of the composition are given in Table I. Almost constant values of expansion coefficients ($\alpha = -(1/\rho)(d\rho/dT)$) over the measured concentration range employed and with the different cations indicate absence of any significant structural changes on addition of the alkali metal nitrates. A smooth change in "mean equivalent expansivity" (coefficient B of V_e-T equation) also supports this.

Equivalent volume (V_e) vs. equivalent fraction (X') isotherms of the $Zn(NO_3)_2 \cdot 6H_2O + LiNO_3$ system (Figure 1) exhibit a small positive deviation (2-5%) in large scale plots (not shown) indicating a decrease in packing density on addition of $LiNO_3$. Li^+ ions having high charge density and greater hydrophilic tendency relative to $Zn(H_2O)_6^{2+}$ ions will probably dehydrate the latter by a displacement reaction of the type



The resultant increased size of (hydrated) Li^+ ions will decrease the packing density of the system. The computed and extrapolated partial equivalent volumes of $LiNO_3$ (taking linear V_e-X'