

Isothermal Vapor-Liquid Equilibrium Data for the Binaries Isobutane-Ethanol, Isobutane-1-Propanol, and Propane-Ethanol

Marcelo S. Zabaloy, Hernán P. Gros, Susana B. Bottini, and Esteban A. Brignole*

PLAPIQUI-UNS/CONICET, CC 717, 8000 Bahía Blanca, Argentina

Vapor-liquid equilibria for the isobutane-ethanol, isobutane-1-propanol, and propane-ethanol systems were measured in the temperature range of 308.6-375.1 K and at pressures up to 43.81 bar. The results show azeotrope formation for the isobutane-ethanol system.

Introduction

The recovery of alcohols from aqueous solutions by supercritical extraction has received considerable attention during the last decade. A revision on this subject is given by Zabaloy et al. (1). Brignole et al. (2) have discussed the application of dual effect (extractant and entrainer) solvents, under critical conditions, for the recovery and dehydration of alcohols from water. Light hydrocarbons appeared to be the most promising near critical fluid (NCF) solvents for these separations. Zabaloy et al. (1, 3, 4) have obtained binary and ternary data which confirmed the applicability of propane, propylene, and isobutane, as dual effect solvents for the recovery and dehydration of 2-propanol. Also, pilot plant studies have confirmed the feasibility of ethanol dehydration by propane (5). In the present work experimental vapor-liquid equilibrium (VLE) data are reported for the binaries isobutane-ethanol, isobutane-1-propanol, and propane-ethanol. One of the main goals of this work is to establish if any of these systems exhibit the undesirable azeotropic behavior (2) between the alcohol and the hydrocarbon.

Experimental Method and Apparatus

Figure 1 presents a diagram of the equilibrium cell. It is a static type cell, cylindrical (horizontally placed), built in brass, 150 cm³ capacity. A window is used for visual observations of the cell content. It consists of a glass disk 20 mm thick. The disk-cell union is sealed via a Viton O-ring. The disk is held in place by a pressing cylinder through a Teflon washer. The experimental setup is shown in Figure 2.

Temperature control is performed by a solid thermostat. It consists of an aluminum shell, two heating resistances, and a proportional controller (YSI Model 72). The aluminum shell tightly houses the brass cell and has external thermal insulation. The controller uses a YSI 400 thermistor probe, which is placed inside a well machined on the aluminum shell. The temperature is measured within the liquid phase by a YSI 700 thermistor probe and read to within 0.1 K in a digital indicator (Cole Parmer Model 8502).

The equilibrium pressure is directly measured with a Bourdon-type digital manometer (Heise-710A, range 0-60 bar) which is connected to the cell through line number 21 in Figures 1 and 2. The manometer is kept at ambient temperature and is placed at the same level as the cell. It was calibrated against atmospheric pressure with a mercury barometer. The accuracy of the pressure measurements was estimated by comparing our experimental vapor pressure data for propane and isobutane against literature values. A deviation of less than 1% on average, with respect to a very accurate correlation of experimental data (6), was found (Table 1).

Table 1. Pure Component Vapor Pressure *P* as a Function of Temperature *T*

<i>T</i> /K	<i>P</i> /bar (this work)	<i>P</i> /bar (lit. (6))	difference, %
Propane			
325.1	18.00	17.84	0.90
350.1	29.60	29.55	0.17
Isobutane			
308.6	4.76	4.68	1.71
318.4	6.11	6.05	0.99
340.8	10.35	10.30	0.49
363.5	16.57	16.53	0.24

Figure 2 shows a diagram of the experimental setup. Manipulation of the cell content, to modify the pressure and liquid level, can be performed by feeding alcohol and/or hydrocarbon into the cell, or by purging some liquid and/or vapor from it. A systematic way of going to the region diluted in the alcohol consists of purging the liquid phase until a considerable liquid level fall is seen through the glass window. Then pure hydrocarbon is fed through the line of valve V3 until a liquid level similar to the initial is observed. It is possible to perform measurements at several temperatures with a single charge of the cell.

Once the cell is filled with the components of interest, the equilibration step starts. The time of this step is minimized by a magnetic stirrer. A pressure close to the final equilibrium value was always reached after 2 or 3 h of having charged the cell. The equilibration times for all the data presented here were greater than 5 h.

In general the difference in density of the liquid and vapor phases allowed a fast phase disengagement process. In general clear phases and meniscuses were seen a few seconds after the stirrer was turned off.

Vapor and liquid compositions were measured by gas chromatography (Hewlett-Packard 5890 with an HP-3392A integrator). The TCD detector was calibrated by injecting known amounts of the pure components, via Hamilton syringes. For all the separations a Porapak Q column was used. The oven temperature was 403 K for isobutane-ethanol, 433 K for isobutane-1-propanol, and 443 K for propane-ethanol.

The liquid-phase sampling line is connected to a Rheodyne Model 7410 sampling valve with internal loops, which is kept 5 K below the cell temperature. The sampling procedure is as follows. First the sampling line is slowly purged. Then, keeping the sampling valve in the load (purge) position, the outlet valve (V4) is closed. The sample inside the loop reaches a pressure close to the cell value. In this way, prior to sample injection, a subcooled liquid fills the liquid-phase loop. Finally the sample is introduced into a chromatograph carrier gas

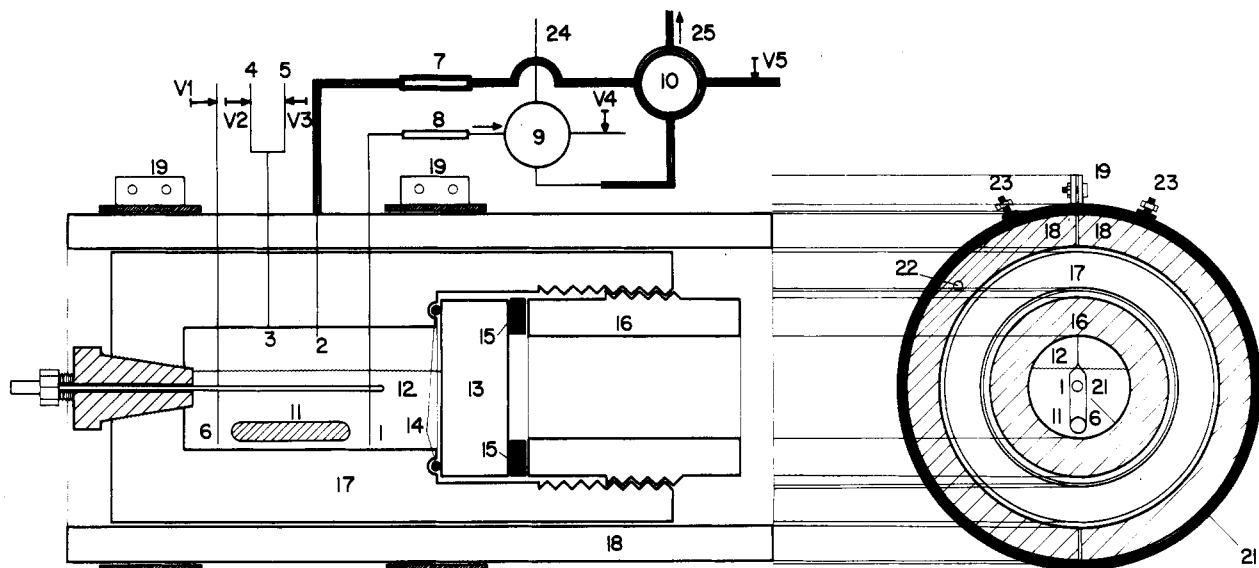

20

Figure 1. Equilibrium cell: (V1-V5) valves; (1) liquid-phase sampling line; (2) vapor-phase sampling line; (3) feeding line; (4) alcohol feeding line; (5) hydrocarbon feeding line; (6) liquid-phase purging line; (7) filter; (8) filter; (9) four-way valve; (10) ten-way valve; (11) stirring magnet; (12) thermistor probe (to the temperature indicator); (13) glass window; (14) Viton O-ring; (15) Teflon washer; (16) pressing cylinder; (17) cell body; (18) aluminum shell; (19) heating resistances; (20) magnetic stirrer; (21) pressure measurement line; (22) temperature controller thermistor well; (23) electric contacts; (24) carrier gas inlet; (25) carrier gas outlet. The thermal insulation is not shown.

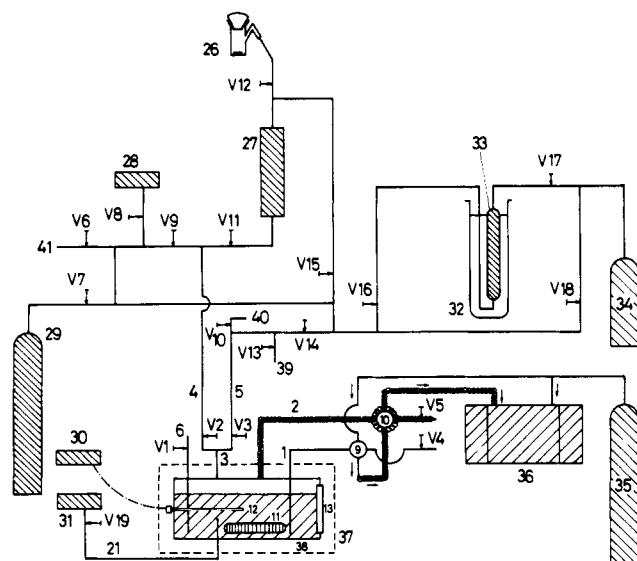

Figure 2. Experimental setup: (V1-V19) valves; (1) liquid-phase sampling line; (2) vapor-phase sampling line; (3) feeding line; (4) alcohol feeding line; (5) hydrocarbon feeding line; (6) liquid-phase purging line; (9) four-way valve; (10) ten-way valve; (11) stirring magnet; (12) thermistor probe (to the temperature indicator); (13) glass window; (21) pressure measurement line; (26) degassing cell; (27) alcohol reservoir; (28) pressure indicator; (29) nitrogen cylinder; (30) temperature indicator; (31) cell pressure indicator (Heise 0-60 bar); (32) cold (or hot) bath; (33) thermocondenser/thermoc compressor; (34) hydrocarbon cylinder; (35) carrier gas cylinder; (36) gas chromatograph; (37) solid thermostat; (38) equilibrium cell; (39) vacuum; (40) vapor-phase purging line; (41) vent.

line (Figure 1). This line is covered with a heating tape, from the outlet of the liquid valve to the chromatograph injection port. The line is kept at a temperature high enough to assure a complete sample vaporization.

Vapor-phase sampling is performed with a Valco C10 TX valve with external loops. This valve is kept at a temperature higher than that of the cell, to guarantee a superheated gas state inside the loop prior to injection.

At least four samples are withdrawn from each phase after equilibration.

The isobutane used for the experiments was from Matheson, instrument purity, 99.5% certified minimum purity, in the liquid phase. Samples of pure isobutane withdrawn from the equilibrium cell showed a minimum of 99.80 area % for the isobutane peak under our chromatographic conditions, for both liquid and vapor phases. Propane was also from Matheson, instrument purity, 99.5%. Samples from the equilibrium cell showed a 99.75 area %. Ethanol was from Merck, pro analysis, 99.8% minimum purity. 1-Propanol was from Aldrich, 99+%, 99.85 area % under our chromatographic conditions.

Results

Three isotherms were measured for each binary. The VLE data obtained are shown in Table 2 for the binary propane-ethanol, Table 3 for isobutane-ethanol, and Table 4 for isobutane-1-propanol. Compositions are given in molar fractions.

Propane (1)-ethanol (2) T-P-X-Y data obtained in this work are plotted in Figure 3. $\lambda_{X(1)}$ and $\lambda_{Y(1)}$ represent the normal distribution limits of error in the mean values of X(1) and Y(1), respectively. They represent the absolute uncertainties (7) in the compositions reported in Table 2 in the presence of random errors only. Otherwise they represent the precision of the experiments. Lower values indicate a better reproducibility. The reproducibility obtained with this apparatus, according to the λ values, is much better than that of a previous work (3). Pressure values in Table 2 result from averaging all the values read before each sampling, from the first liquid-phase analysis, to the last vapor-phase one. The symbol λ_P represents the absolute fluctuation in pressure

Table 2. Experimental Vapor-Liquid Equilibrium Data for the System Propane (1)-Ethanol (2): P = Absolute Pressure (bar), λ_P = Pressure Fluctuation (bar), X = Liquid-Phase Molar Fraction, λ_X = Precision of X , Y = Vapor-Phase Molar Fraction, λ_Y = Precision of Y , K = Distribution Coefficient, T = Temperature (K)

P /bar	λ_P	$X(1)$	$\lambda_{X(1)}$	$Y(1)$	$\lambda_{Y(1)}$	$K(2)$
$T/K = 325.1$						
9.74	0.02	0.169	0.003	0.9737	0.0002	0.032
13.29	0.04	0.293	0.002	0.980	0.001	0.028
16.71	0.02	0.701	0.003	0.9860	0.0002	0.047
17.08	0.01	0.785	0.002	0.985	0.001	0.067
17.53	0.02	0.881	0.003	0.9883	0.0004	0.098
18.00		1.000		1.000		
$T/K = 350.1$						
13.57	0.03	0.160	0.001	0.935	0.001	0.077
20.70	0.15	0.305	0.002	0.958	0.001	0.060
26.91	0.02	0.684	0.001	0.9663	0.0003	0.107
27.46	0.01	0.772	0.002	0.968	0.002	0.141
28.62	0.03	0.858	0.002	0.9734	0.0004	0.188
29.60		1.000		1.000		
$T/K = 375.1$						
20.19	0.13	0.171	0.001	0.874	0.004	0.152
30.18	0.08	0.319	0.001	0.916	0.003	0.123
38.97	0.03	0.597	0.003	0.9207	0.0002	0.197
41.09	0.09	0.720	0.001	0.934	0.003	0.236
43.81	0.02	0.837	0.014	0.943	0.001	0.349

Table 3. Experimental Vapor-Liquid Equilibrium Data for the System Isobutane (1)-Ethanol (2): P = Absolute Pressure (bar), λ_P = Pressure Fluctuation (bar), X = Liquid-Phase Molar Fraction, λ_X = Precision of X , Y = Vapor-Phase Molar Fraction, λ_Y = Precision of Y , K = Distribution Coefficient, T = Temperature (K)

P /bar	λ_P	$X(1)$	$\lambda_{X(1)}$	$Y(1)$	$\lambda_{Y(1)}$	$K(2)$
$T/K = 308.6$						
3.92	0.02	0.300	0.010	0.974	0.001	0.037
4.36	0.00	0.493	0.001	0.9788	0.0003	0.042
4.52	0.00	0.701	0.004	0.9812	0.0004	0.063
4.64	0.00	0.861	0.002	0.9833	0.0003	0.120
4.71	0.00	0.932	0.003	0.9876	0.0003	0.183
4.74	0.00	0.960	0.002	0.9893	0.0002	0.270
4.76	0.00	0.985	0.001	0.9913	0.0001	0.565
4.77	0.00	0.9918	0.0002	0.9929	0.0001	0.866
4.77	0.01	0.9964	0.0001	0.9959	0.0001	1.139
4.76		1.000		1.000		
$T/K = 318.4$						
4.57	0.01	0.210	0.002	0.9664	0.0004	0.042
5.44	0.01	0.392	0.002	0.973	0.002	0.044
5.49	0.00	0.398	0.015	0.974	0.001	0.043
5.73	0.00	0.606	0.003	0.9763	0.0001	0.060
5.90	0.00	0.753	0.003	0.978	0.001	0.091
6.00	0.00	0.841	0.008	0.9792	0.0003	0.131
6.14	0.00	0.955	0.002	0.9833	0.0001	0.370
6.17	0.00	0.9881	0.0002	0.9892	0.0001	0.908
6.15	0.00	0.9944	0.0001	0.9931	0.0001	1.232
6.11		1.000		1.000		
$T/K = 363.5$						
3.38	0.09	0.021	0.001	0.614	0.006	0.394
7.10	0.07	0.081	0.001	0.815	0.001	0.201
11.19	0.02	0.1885	0.0004	0.8980	0.0003	0.126
14.00	0.00	0.370	0.001	0.925	0.001	0.119
15.18	0.00	0.601	0.003	0.931	0.002	0.173
15.98	0.01	0.763	0.002	0.9380	0.0002	0.262
16.22	0.00	0.835	0.004	0.9467	0.0004	0.324
16.30	0.00	0.841	0.004	0.946	0.001	0.339
16.53	0.01	0.893	0.002	0.951	0.001	0.456
16.69	0.01	0.957	0.001	0.9655	0.0005	0.795
16.71	0.01	0.989	0.002	0.9865	0.0001	1.184
16.57		1.000		1.000		

around the mean value during the sampling process. The pressure drop produced during this process is lower for the liquid phase than for the vapor phase. For this reason the liquid-phase analysis is performed first. For the system propane (1)-ethanol (2) our liquid-phase results disagree with

Table 4. Experimental Vapor-Liquid Equilibrium Data for the System Isobutane (1)-1-Propanol (2): P = Absolute Pressure (bar), λ_P = Pressure Fluctuation (bar), X = Liquid-Phase Molar Fraction, λ_X = Precision of X , Y = Vapor-Phase Molar Fraction, λ_Y = Precision of Y , K = Distribution Coefficient, T = Temperature (K)

P /bar	λ_P	$X(1)$	$\lambda_{X(1)}$	$Y(1)$	$\lambda_{Y(1)}$	$K(2)$
$T/K = 318.4$						
4.27	0.02	0.265	0.001	0.9853	0.0001	0.020
5.28	0.01	0.529	0.008	0.9891	0.0001	0.023
5.40	0.06	0.554	0.008	0.9894	0.0002	0.024
5.68	0.05	0.755	0.001	0.9904	0.0002	0.039
5.82	0.01	0.851	0.005	<i>a</i>		
6.01	0.01	0.970	0.001	0.9940	0.0002	0.202
6.07	0.01	0.9944	0.0001	0.9973	0.0001	0.482
6.11		1.000		1.0000		
$T/K = 340.8$						
4.18	0.04	0.121	0.001	0.946	0.001	0.061
5.84	0.01	0.195	0.002	0.962	0.001	0.047
8.36	0.09	0.429	0.011	0.974	0.001	0.045
8.56	0.01	0.465	0.003	<i>a</i>		
9.37	0.01	0.721	0.001	0.9766	0.0004	0.084
9.74	0.03	0.836	0.002	0.983	0.001	0.104
10.11	0.01	0.964	0.001	0.9886	0.0003	0.321
10.30	0.01	0.9948	0.0001	0.9972	0.0001	0.538
10.35		1.000		1.000		
$T/K = 363.6$						
5.60	0.03	0.100	0.006	0.851	0.006	0.166
9.72	0.02	0.234	0.002	0.926	0.005	0.097
11.66	0.15	0.358	0.002	0.946	0.001	0.084
14.50	0.05	0.646	0.007	0.961	0.001	0.109
15.40	0.06	0.814	0.002	0.9690	0.0002	0.167
16.41	0.02	0.977	0.002	0.9894	0.0003	0.455
16.52	0.02	0.9951	0.0001	0.9969	0.0001	0.633
16.57		1.000		1.000		

^a Sample lost.

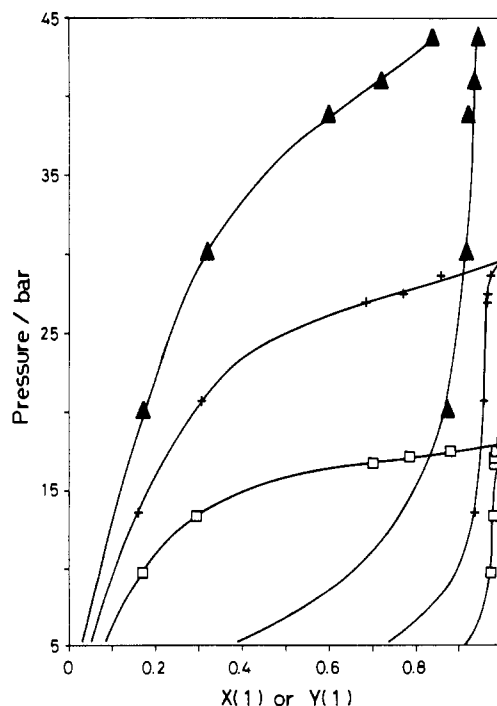

Figure 3. Vapor-liquid equilibrium data for the propane (1)-ethanol (2) system: (\square) 325.1 K, (+) 350.1 K, (\blacktriangle) 375.1 K.

those from Gomez-Nieto and Thodos (8). They obtained higher liquid-phase propane concentrations at fixed T, P coordinates. Their values are around 75% greater, on average, than ours. Probably their rather involved method for sample manipulation resulted in a selective sampling of the more volatile (propane) component. In contrast our

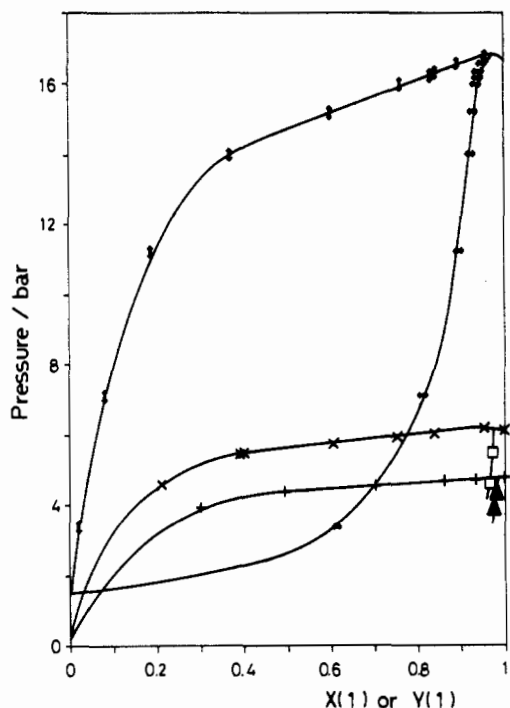

Figure 4. Vapor-liquid equilibrium data for the isobutane (1)-ethanol (2) system: (+) liquid-phase data at 308.6 K; (x) liquid-phase data at 318.4 K; (†) liquid-phase data at 363.5 K; (Δ) vapor-phase data at 308.6 K; (□) vapor-phase data at 318.4 K; (⇌) vapor-phase data at 363.5 K.

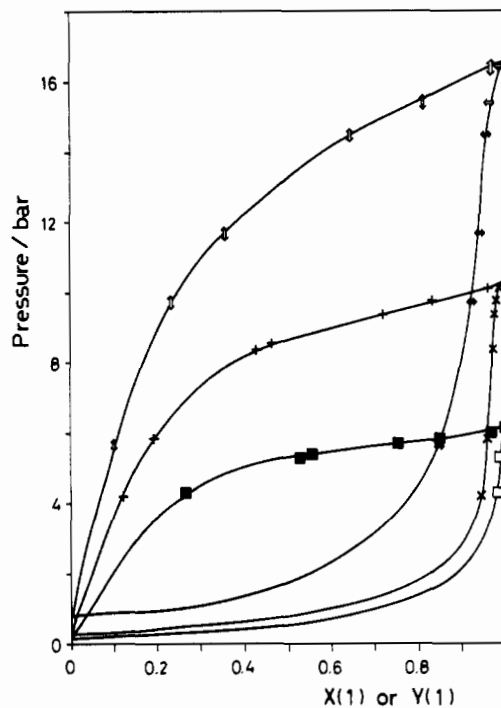

Figure 6. Vapor-liquid equilibrium data for the isobutane (1)-1-propanol (2) system: (■) liquid-phase data at 318.4 K; (+) liquid-phase data at 340.8 K; (†) liquid-phase data at 363.6 K; (□) vapor-phase data at 318.4 K; (x) vapor-phase data at 340.8 K; (⇌) vapor-phase data at 363.6 K.

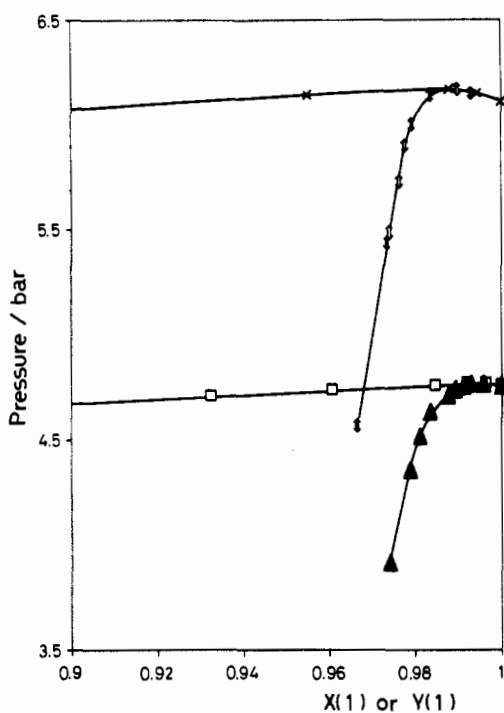

Figure 5. Vapor-liquid equilibrium data for the isobutane (1)-ethanol (2) system in the region diluted in ethanol: (□) liquid-phase data at 308.6 K; (x) liquid-phase data at 318.4 K; (Δ) vapor-phase data at 308.6 K; (†) vapor-phase data at 318.4 K.

method minimizes the number of intermediate steps for sample transfer from the equilibrium cell to the chromatograph column. Propane activity coefficients estimated from the data of Gomez-Nieto and Thodos are low when compared to the values measured by Nagahama et al. (9).

Table 3 shows the VLE data for the isobutane (1)-ethanol (2) system. For scale reasons they are plotted in two figures:

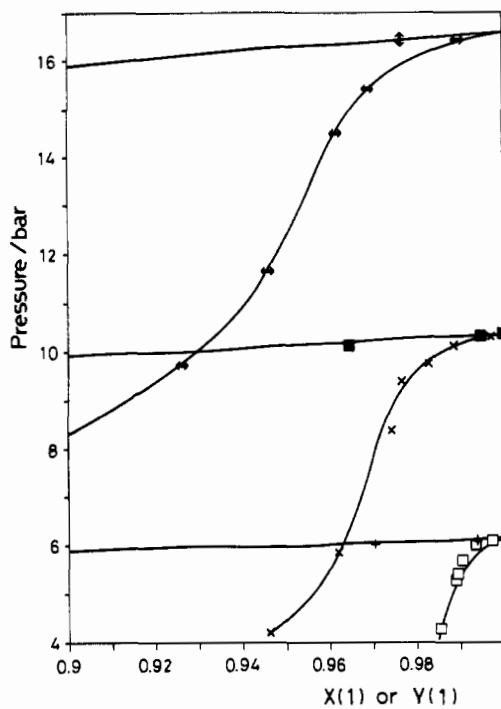

Figure 7. Vapor-liquid equilibrium data for the isobutane (1)-1-propanol (2) system in the region diluted in 1-propanol: (+) liquid-phase data at 318.4 K; (■) liquid-phase data at 340.8 K; (⇌) liquid-phase data at 363.6 K; (□) vapor-phase data at 318.4 K; (x) vapor-phase data at 340.8 K; (†) vapor-phase data at 363.6 K.

Figures 4 and 5. This system shows azeotropic behavior. First a pressure maximum is observed near the pure isobutane point. Second the ethanol distribution coefficient $K(2)$ assumes values below and above unity at nontrivial equilibrium points. Composition values in the azeotropic region are, in some cases, on the order of that corresponding to the

isobutane purity level. They were calculated by ignoring those chromatographic peaks corresponding to impurities. For this reason $X(1)$ and $Y(1)$ values in the region highly diluted in the alcohol could be, to some extent, erroneous. However, $K(2)$ values calculated as $Y(2)/X(2)$ are reliable and can be taken as a confirmation of the azeotropic behavior.

The experimental azeotropic isobutane mole fractions are 0.9944 ± 0.0020 at 308.6 K, 0.9911 ± 0.0020 at 318.4 K, and 0.9760 ± 0.0105 at 363.5 K.

Data for the system isobutane-1-propanol are shown in Table 4 and in Figures 6 and 7. There is no azeotrope formation for this system under the present experimental conditions.

Conclusions

The azeotropic behavior for the system isobutane-ethanol hinders the application of isobutane as a solvent for the supercritical extraction of ethanol from aqueous solutions. However, nonazeotropic behavior was found for the binary of isobutane with 1-propanol. In a previous paper no azeotrope formation was reported for the isobutane-2-propanol system (4). Therefore, isobutane can be used for the near-critical extraction and dehydration of 1-propanol, 2-propanol, and higher alcohols, but not for ethanol.

Acknowledgment

We want to thank Nicolas Carestia for operating the equipment during the measurement of the data with isobutane.

Literature Cited

- (1) Zabaloy, M. S.; Mabe, G. D. B.; Bottini, S. B.; Brignole, E. A. *J. Supercrit. Fluids* 1992, 5, 186.
- (2) Brignole, E. A.; Andersen, P. M.; Fredenslund, Aa. *Ind. Eng. Chem. Res.* 1987, 26, 2, 254.
- (3) Zabaloy, M. S.; Mabe, G. D. B.; Bottini, S. B.; Brignole, E. A. *J. Chem. Eng. Data* 1993, 38, 1, 40.
- (4) Zabaloy, M. S.; Mabe, G. D. B.; Bottini, S. B.; Brignole, E. A. *Fluid Phase Equilib.* 1993, 83, 159.
- (5) Horizoe, H.; Tanimoto, T.; Yamamoto, I.; Ogawa, K.; Kano, Y.; Maki, M. *Proceedings of the 2nd International Symposium on Supercritical Fluids*, Boston, MA, May 1991; p 105.
- (6) Zhong, X. *Ind. Eng. Chem. Process Des. Dev.* 1984, 23, 7.
- (7) Shoemaker, D. P.; Garland, C. W. *Experiments in Physical Chemistry*, 2nd ed.; McGraw-Hill Book Co.: New York, 1967; Chapter II.
- (8) Gómez-Nieto, M.; Thodos, G. *AIChE J.* 1978, 24, 4, 672.
- (9) Nagahama, K.; Suda, S.; Hakuta, T.; Hirata, M. *Sekiyu Gakkai Shi* 1971, 14, 252.

Received for review April 6, 1993. Revised October 25, 1993.
Accepted December 6, 1993.*

* Abstract published in *Advance ACS Abstracts*, March 1, 1994.