

# Temperature- and Pressure-Induced Crystallization and Melting of Tetracontane in Propane: Evidence of Retrograde Crystallization

Marek Łuszczak

Institute of Physical Chemistry, Polish Academy of Sciences, ul. Kasprzaka 44/52, 01–224 Warszawa, Poland

Maciej Radosz\*

Department of Chemical and Petroleum Engineering, University of Wyoming, Laramie, Wyoming 82071-3295

The crystallization and melting transitions for tetracontane in propane, measured in this work at pressures up to about 1200 bar, are found to exhibit a temperature minimum, which implies crystallization upon decompression (retrograde crystallization). The supercooling effect, which is the difference between the crystallization and melting temperature, is found to decrease with increasing tetracontane concentration. The transitions induced by varying temperature at constant pressure are found to fall near the same curve as those induced by varying pressure at constant temperature. The difference between the crystallization and melting pressure represents the super-compression effect.

## Introduction

To design and improve polymer processes, we need a better understanding of the phase behavior of polymer solutions. We also need quantitative data, including temperatures and pressures at which a homogeneous mixture of given composition phase separates or a heterogeneous mixture becomes homogeneous. We need such data either to avoid an undesirable phase separation, for example a phase separation that leads to fouling, or to induce a desirable phase separation, for example a phase separation that leads to monomer or solvent recovery.

An example of phase behavior data needed to understand fouling is the temperature- and pressure-induced crystallization and melting. The goal of this work is to measure such crystallization and melting data for a low-molecular prototype of linear polyethylene, such as tetracontane, dissolved in a small alkane solvent such as propane. Chan et al.<sup>1</sup> measured similar data for this system by varying just the temperature at relatively high cooling and heating rates. However, they did not measure the pressure-induced transitions, did not keep the rates constant and low enough, and did not focus on the low-pressure transitions where the crystallization and melting temperatures exhibit a minimum.

## Experimental Section

The materials used in this study are tetracontane (98%), obtained from Aldrich Chemical Co., and propane (C. P. grade, 99.0% minimum purity), obtained from Matheson Gas Products, Inc. They were used without further purification.

The measurements were carried out in a high-pressure cell coupled with a transmitted-light intensity probe and a borescope for visual observation of the phase transitions. The pressure was measured with a (0 to 2000) bar pressure transducer to within  $\pm 0.1$  bar, and the temperature was measured with a three-wire class A RTD probe to within

\* To whom correspondence should be addressed. E-mail: Radosz@uwo.edu. Phone: 307 766 2500. Fax: 307 766 6777.

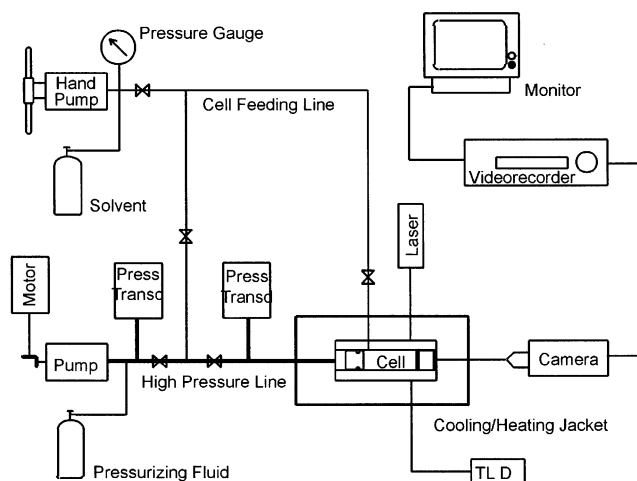
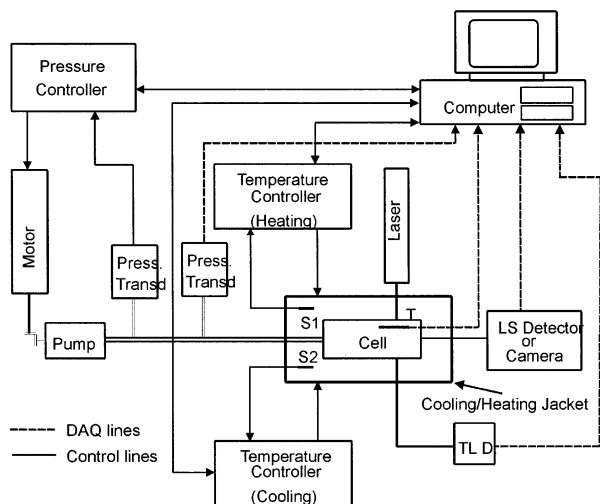

Figure 1. Schematic diagram of the apparatus.

$\pm 0.1$  °C. A simplified schematic of the apparatus is shown in Figure 1 where TL D indicates the transmitted-light intensity probe. A detailed description of the apparatus, the precision, and the experimental procedure are given by Chan et al.<sup>1,2</sup>

The apparatus used in this work was recently equipped with a new data-acquisition and control system, shown in Figure 2. The upgrade includes the following: a cooling-heating jacket for the cell, circulating bath, temperature and pressure control program, and data acquisition program. The cooling-heating jacket allows for electric heating and liquid-bath heating and cooling. The temperature and pressure control program allows not only for constant temperature and pressure experiments but also for decreasing or increasing temperature at a constant rate. The pressure rate was controlled by using an adjustable, but constant, pump rate. The data acquisition program allows for collecting complete sets of experimental data, which later were analyzed and plotted.

All samples were prepared by mass. The total solution volume was of the order of 1 cm<sup>3</sup>. All phase transitions were



**Figure 2.** Schematic diagram of the data-acquisition and control systems.

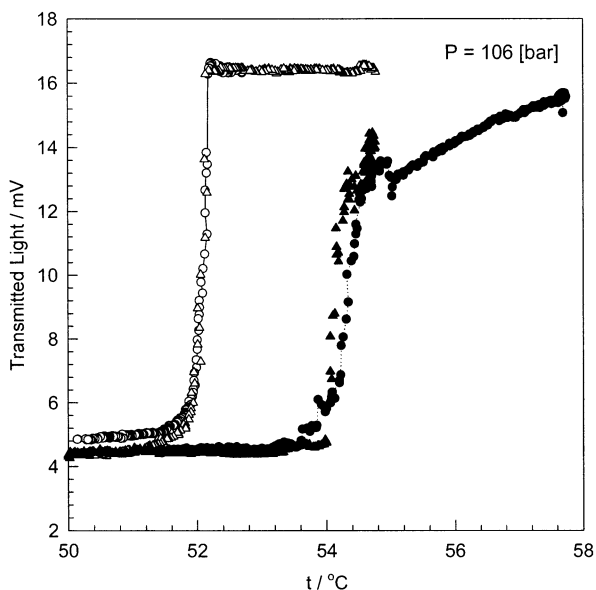
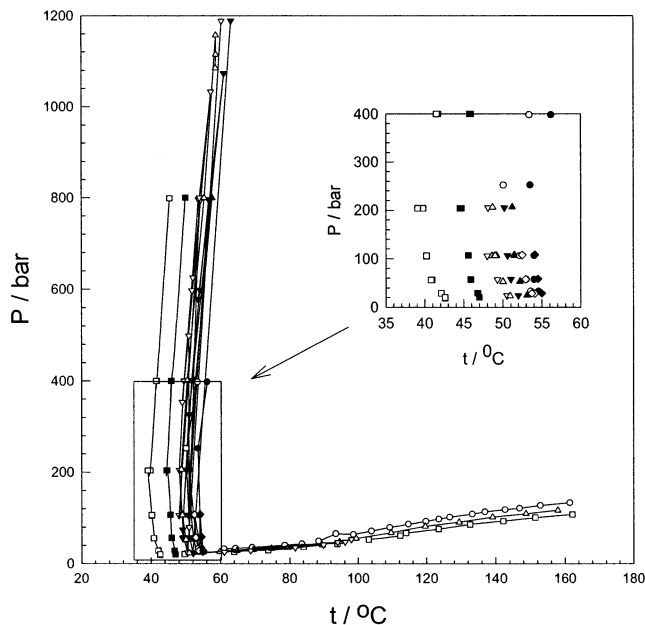

**Figure 3.** Example of the transmitted-light intensity plotted versus temperature for 12.7 wt % tetracontane at 106 bar obtained for heating and cooling rates of about  $0.1 \text{ }^\circ\text{C}\cdot\text{min}^{-1}$ . The points shown in this figure were obtained from two separate experiments (circles and triangles).

determined visually, but each experimental record also includes the transmitted-light intensity data. The heating and cooling rates were of the order of  $0.1 \text{ }^\circ\text{C}\cdot\text{min}^{-1}$ , during which the temperature inside the cell was essentially the same as the temperature of the cell's body, as determined by some test experiments. Under atmospheric pressure, the cell was filled with isooctane and additional RTD probe was placed in the cell. During heating and cooling with different rates, the temperatures inside the cell and of the body were recorded. We found that for the reported rate the difference was comparable to precision of the temperature measurements. The pressure change rate was about  $5 \text{ bar}\cdot\text{min}^{-1}$ , which was the lowest achievable.

## Results and Discussion

A typical example of the transmitted-light intensity traces is presented in Figure 3 where the solid symbols indicate the melting data and the open symbols indicate the crystallization data. Both melting and crystallization



**Figure 4.** Pressure-temperature phase diagram as a function of concentration of tetracontane: (□, ■) 1.9 wt %; (▽, ▲) 7.1 wt %; (△, ▼) 7.6 wt %; (○, ●) 12.7 wt %; and (◇, ◆) 14.9 wt %; open symbols, crystallization; solid symbols, melting.

are induced by changing temperature at constant pressure of 106 bar. Figure 3 also presents two experiments to indicate the extent of a typical reproducibility. As we can see, the crystallization data obtained from the two experiments nearly coincide while the melting data show a little discrepancy. In general, the reproducibility is estimated to be within  $0.5 \text{ }^\circ\text{C}$ .

Because the crystallization and melting temperatures obtained in this work are found to be systematically higher than those published by Chan et al.,<sup>1</sup> we had our data independently verified by Plancher<sup>3</sup>: Plancher's data coincide with ours within the experimental accuracy. For example, for 7.1 wt % tetracontane and propane, Plancher measured the temperature-induced crystallization at 600 bar to be  $51.5 \text{ }^\circ\text{C}$  ( $0.3 \text{ }^\circ\text{C}\cdot\text{min}^{-1}$ ), temperature-induced melting to have the onset at  $53.4 \text{ }^\circ\text{C}$ , and the peak at  $55.3 \text{ }^\circ\text{C}$  ( $0.2 \text{ }^\circ\text{C}\cdot\text{min}^{-1}$ ), and the pressure-induced crystallization at  $52.8 \text{ }^\circ\text{C}$  to be at (650 to 658) bar ( $1 \text{ bar}\cdot\text{min}^{-1}$ ).

Therefore, we conclude that Chan et al.'s<sup>1</sup> data are inaccurate. The most likely reason is that their heating and cooling rates were relatively high and not well controlled, for example, as high as ( $0.5$  to  $1$ )  $^\circ\text{C}\cdot\text{min}^{-1}$ , which is nearly 10 times higher than the rates used in this work. In an independent study, Plancher et al.<sup>4</sup> show that such high rates may indeed lead to inaccurate results.

Both crystallization and melting temperatures are found to be concentration-dependent. Figure 4 illustrates this dependence in a pressure-temperature phase diagram for five concentrations: (1.9, 7.1, 7.6, 12.7, and 14.9) wt % of tetracontane in propane, where the crystallization and melting temperatures were measured by changing temperature at constant pressure. As usual, the crystallization and melting temperatures decrease with decreasing concentration. Figure 4 also illustrates a common finding that the crystallization temperature, shown with open symbols, is always lower than the melting temperature, shown with solid symbols. We shall further discuss this finding in one of the following paragraphs. Because the crystallization and melting curves shown in Figure 4 exhibit a substantial slope, a separate attempt was made to measure the

**Table 1. Results Summary for the Tetracontane+Propane System**

$t$	$p$	transition type	$t$	$p$	transition type	$t$	$p$	transition type
°C	bar	comment <sup>a</sup>	°C	bar	comment <sup>a</sup>	°C	bar	comment <sup>a</sup>
1.9 wt % Tetracontane								
49.6	20.7	FV	162.2	107.5	FL	45.6	106.9	FS(h)
63.9	25.7	FV	41.7	400.0	FS(c)	40.9	56.2	FS(c)
73.8	29.2	FV	45.8	400.0	FS(h)	45.9	56.8	FS(h)
84.1	36.3	FV	41.5	400.0	FS(c)	40.8	55.9	FS(c)
94.0	43.5	FV	45.9	400.0	FS(h)	45.9	56.9	FS(h)
103.1	52.9	FL	39.8	204.0	FS(c)	42.1	28.7	FS(c)
112.3	61.5	FL	44.5	204.0	FS(h)	46.8	28.7	FS(h)
114.0	66.7	FL	39.1	203.8	FS(c)	42.6	19.0	FS(c)
123.4	75.7	FL	44.7	204.0	FS(h)	47.0	20.4	FS(h)
132.6	85.9	FL	40.2	105.4	FS(c)	42.6	20.0	FS(c)
142.1	93.2	FL	45.6	106.9	FS(h)	45.4	799.2	FS(c)
151.4	100.6	FL	40.2	106.0	FS(c)	49.9	800.1	FS(h)
7.1 wt % Tetracontane								
48.0	105.8	FS(c)	48.1	205.0	FS(c)	49.0	204.3	Starting point in metastable region
50.6	106.4	FS(h)	50.2	205.1	FS(h)	49.0	353.6	FS(u) Solid phase appears
52.1	625.0	FS(u)	49.3	57.1	FS(c)	57.3	1033.0	FS(u)
53.7	796.7	FS(u)	51.0	57.5	FS(h)	63.2	1189.1	FS(h)
53.8	796.4	FS(u)	50.5	23.7	FS(c)	60.4	1188.8	FS(c)
53.6	577.9	FS(d)	50.9	23.3	Starting point (solid-phase exists)	61.1	1073.2	FS(d) Solid-phase disappears
54.0	800.0	FS(u)	50.9	79.6	FS(u) Solid-phase disappears	61.1	25.2	FV
54.3	794.9	FS(c)	50.9	498.7	FS(u) Solid phase appears	68.7	28.3	FV
56.7	795.5	FS(h)	50.9	326.6	FS(d) Solid-phase disappears	81.6	35.3	FV
51.8	597.3	FS(c)	49.2	203.8	Starting point in metastable region (homogeneous)	89.9	41.4	FV
54.1	598.7	FS(h)	49.1	74.3	FS(d) Solid phase appears	96.2	47.7	FL
49.5	400.5	FS(c)	52.0	23.8	FS(h)	94.0	47.2	FVL Three phase point
51.7	401.6	FS(h)	52.1	22.4	FV	98.0	53.2	FL
7.6 wt % Tetracontane								
48.9	105.7	FS(c)	51.2	206.6	FS(h)	74.7	32.9	FV
51.5	107.2	FS(h)	50.4	400.7	FS(c)	79.4	34.8	FV
49.2	106.4	FS(c)	52.8	401.1	FS(h)	89.5	41.1	FV
51.5	106.2	FS(h)	55.4	799.4	FS(c)	94.6	47.8	FL
49.0	106.4	FS(c)	57.7	799.4	FS(h)	99.4	55.3	FL
51.4	106.9	FS(h)	58.7	1085.1	FS(u)	109.6	68.0	FL
50.0	52.5	FS(c)	48.6	105.9	FS(c)	119.8	81.6	FL
52.2	53.2	FS(h)	58.8	1114.9	FS(u)	129.4	90.7	FL
50.0	53.0	FS(c)	59.8	1157.3	FS(u)	139.1	102.0	FL
52.2	53.5	FS(h)	59.8	26.0	FV	148.7	109.3	FL
50.9	23.4	FS(c)	55.0	24.9	FV	157.9	116.7	FL
53.1	24.4	FVS(h)	64.7	27.9	FV			
48.7	206.1	FS(c) (Three phase point?)	69.5	29.6	FV			
12.7 wt % Tetracontane								
53.4	398.0	FS(c)	61.0	32.6	FV	114.7	86.2	FL
50.1	252.0	FS(c)	64.4	33.7	FV	119.8	92.6	FL
52.2	106.0	FS(c)	69.2	35.7	FV	123.5	97.7	FL
53.0	57.0	FS(c)	78.6	40.4	FV	126.7	101.8	FL
53.6	33.0	FS(c)	83.6	43.2	FV	133.2	108.4	FL
56.2	398.0	FS(h)	88.5	49.4	FL	136.9	113.2	FL
55.5	252.0	FS(h)	93.5	56.6	FL	142.7	117.9	FL
54.0	106.0	FS(h)	98.6	64.2	FL	146.9	121.4	FL
54.0	57.0	FS(h)	103.9	71.6	FL	152.9	127.0	FL
54.6	33.0	FS(h)	109.3	79.3	FL	161.5	133.1	FL
14.9 wt % Tetracontane								
52.5	107.5	FS(c)	54.5	58.5	FS(h)	55.0	28.4	FS(h)
54.1	108.1	FS(h)	54.9	25.1	FV	53.7	28.3	FS(c)
52.9	57.7	FS(c)	54.1	28.0	FS(c)			

<sup>a</sup> Abbreviations: F, fluid; L, liquid; S, solid; V, vapor; (c), cooling; (h), heating; (d), pressure down; (u), pressure up.

crystallization and melting data not only by varying temperature but also by varying pressure. As a result of this experiment, we found that the temperature-induced crystallization points and pressure-induced crystallization

points fall close to a single curve. We found the same behavior for the melting points.

The experimental are listed in Table 1 and plotted in Figure 5 for a solution containing 7.1 wt % of tetracontane.

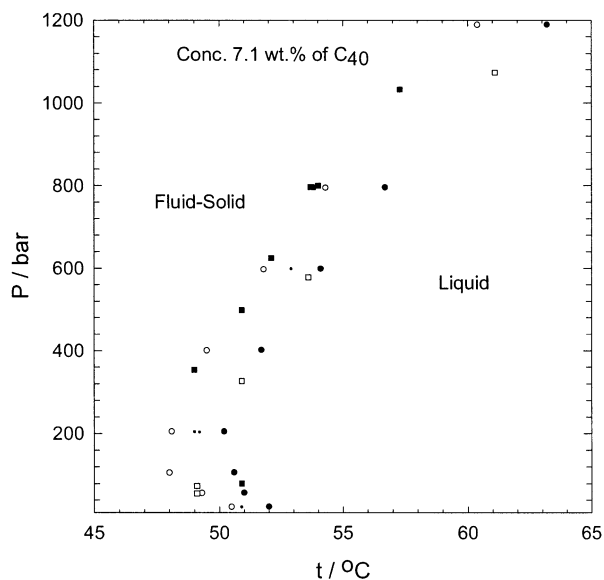

**Figure 5.** Pressure-temperature phase diagram for 7.1 wt % tetracontane in propane: pressure- (squares) and temperature-induced (circles) transitions fall on the same curves.

The small single dots placed between melting and crystallization lines at (200 and 600) bar shown in Figure 5 indicate auxiliary temperature experiments aimed at probing the metastable region between the curves. In each case, we approached the temperature indicated by the dot from both sides, from the low-temperature side with the solid phase present and from the high-temperature side with the solid-phase absent, and then waited for an extended period of time, up to several days, while the sample was stirred at constant conditions. Invariably, we found no change in the initial phase state, for at least (2 to 5) h for crystallization and regardless of the residence time for melting. We found the same behavior in a pressure experiment, shown as a second dot at 200 bar, when we approached 200 bar from the low-pressure side with the solid-phase absent and from the high-pressure side with the solid phase present.

Figure 5 also shows that both the melting (higher temperature) and crystallization (lower temperature) curves exhibit a characteristic temperature minimum, around (100 to 200) bar, before they reach the fluid-vapor line (not shown in Figure 5, but shown in Figure 4). The minimum is deep enough, about (2 to 3) °C on the low-pressure side, to allow for crystallization that can be induced by either increasing or decreasing pressure. For example, one can start at the (49 °C 200) bar dot with no solid phase present and crystallize the dissolved tetracontane by either increasing pressure (solid square) or decreasing pressure (open square).

The concentration dependence of the crystallization and melting curves shown in Figure 4 is further illustrated in Figure 6 where the temperature is plotted against the weight percent of tetracontane at 106 bar. As it is commonly found for low-melting solvents, such as propane, the crystallization and melting temperatures asymptotically reach the crystallization and melting temperatures of pure tetracontane at the high concentration end (not shown in Figure 6 where the weight percent axis is truncated at 16) and sharply decrease at the low concentration end.

The difference between the melting and crystallization temperatures is found to be around (5 to 6) °C at about 2 wt %, and it is found to decrease with increasing tetracontane concentration to about (1 to 2) °C at 15 wt %. This difference is plotted in Figure 7 against the weight percent of tetracontane at 106 bar. It is safe to hypothesize that

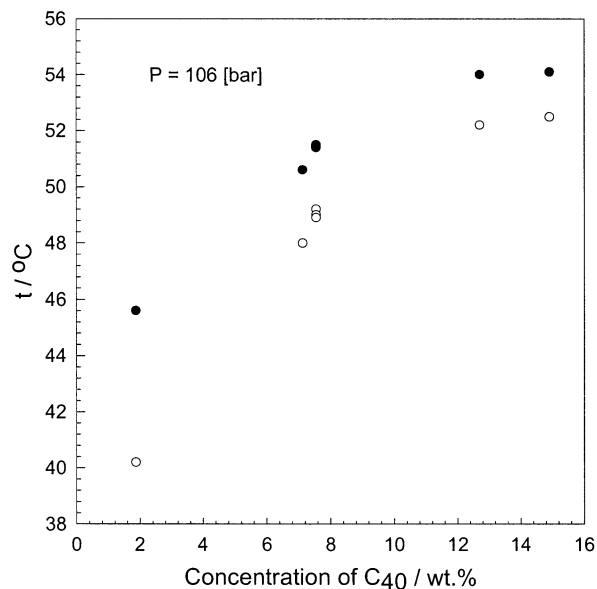

**Figure 6.** Temperature-weight percent phase diagram for tetracontane in propane at 106 bar. The crystallization and melting temperatures increase with increasing concentration of tetracontane.

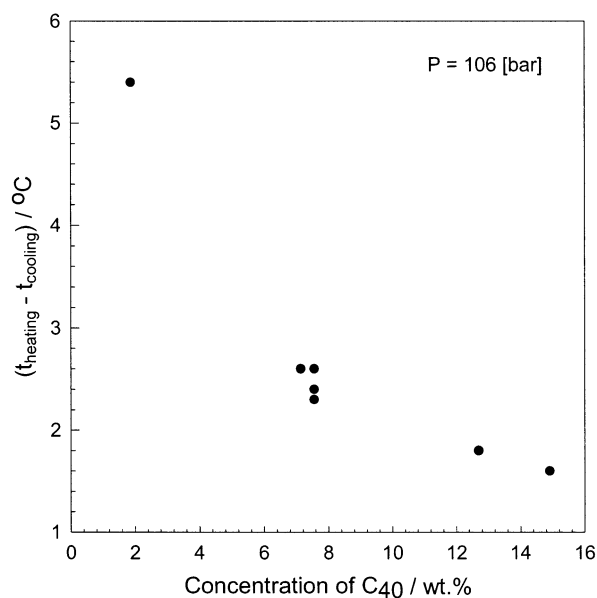

**Figure 7.** Difference between the melting temperature (heating) and crystallization temperature (spontaneous appearance of the solid phase on cooling) as a function of the tetracontane weight percent. The difference decreases with increasing concentration of tetracontane.

this difference is likely to continue decreasing as the weight percent of tetracontane increases all of the way to its pure state. Although the melting-crystallization temperature difference for pure tetracontane is not available, the melting-crystallization temperature difference has recently been measured by Łuszczuk and Rogalski<sup>5</sup> and Łuszczuk<sup>6</sup> for other pure compounds.

An example of a crystallization experiment on a pure compound is shown in Figure 8, which illustrates typical cooling curves for pure octanol-1, obtained at different cooling rates and plotted in temperature-versus-time coordinates by Łuszczuk and Rogalski.<sup>5</sup> The experiment starts at high temperature where the alcohol is a liquid. Upon cooling, the temperature steeply and monotonically decreases down to a point where crystals are rapidly and

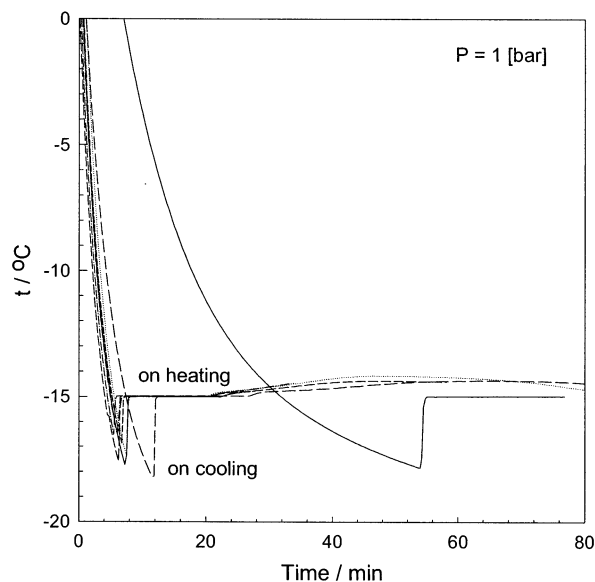

**Figure 8.** Typical trace obtained during cooling of octanol-1, (Łuszczak and Rogalski<sup>5</sup>) for different cooling rates. The negative peaks observed toward the end of cooling the sample represent a supercooling effect. The temperature of a cooling jacket is not shown.

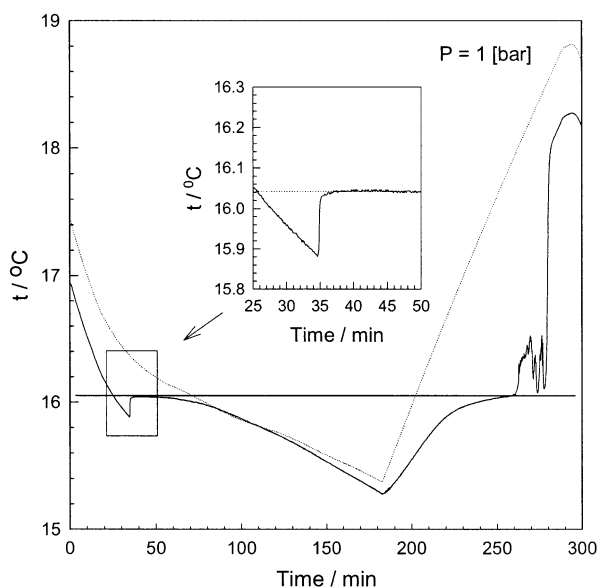

**Figure 9.** Typical trace obtained by Łuszczak<sup>6</sup> during cooling and heating of hexadecane. The negative peak observed toward the end of cooling the liquid represents a supercooling effect; solid line, temperature inside of the sample; dotted line, temperature of the jacket.

spontaneously formed (similar to what we observe in this work where the tetracontane crystals are rapidly and spontaneously formed throughout the sample). At this point, the temperature sharply increases to the level shown as a flat plateau in Figure 8.

An example of a cooling and heating curve measured by Łuszczak<sup>6</sup> for pure hexadecane is shown in Figure 9. The noise in the sample temperature (solid line) around 270 min is caused by cracking of crystal agglomerates, while the sample is vigorously stirred, which develops melting surface. The horizontal line indicates the solid-liquid equilibrium temperature. We show both examples because of the large difference in the size of the peak, that is a small fraction of a degree for hexadecane (around 0.2 °C in the inset in Figure 9) compared to about 3 °C for octanol-1.

We expect that a similar (0.2 °C) difference would be observed for tetracontane.

The negative peaks observed in Figures 8 and 9 characterize the extent of supercooling needed to allow the crystals to form, which is the extent of the metastable state separating the cooling-induced and heating-induced transitions on the temperature scale. Such a metastable state may take a long time to change, hours or even days. The difference between the peak temperature and the plateau temperature is reminiscent of the difference between the melting and crystallization temperatures observed in this work for the propane solutions of tetracontane. We cannot detect such a peak in this work because the mass of our sample is too small relative to the mass of the cell. The analysis of Figures 8 and 9 leads us to interpret the melting transition, and not the crystallization transition, measured in this work as a phase-equilibrium transition.

Regarding terminology, the supercooling effect discussed above refers to and is quantified by varying the temperature. As shown in Figure 5, we observed a similar difference between crystallization and melting by varying pressure. The pressure-induced effect can be referred to as a super-compression effect; we need to overcompress the solution to initiate a process of crystal formation.

## Conclusions

The crystallization and melting transitions for tetracontane in propane, measured in this work up to about 1200 bar, are found to exhibit a temperature minimum, for example around (100 to 200) bar for solutions containing about 7 wt % of tetracontane, which is the evidence of retrograde crystallization, that is, crystallization upon decompression.

The supercooling effect, which is the difference between the crystallization and melting temperature, is found to decrease with increasing tetracontane concentration, for example from about (5 to 6) °C at concentrations as low as 2 wt % to (1–2) °C at about 15 wt %.

The transitions induced by varying temperature at constant pressure are found to fall near the same curve as those induced by varying pressure at constant temperature. The difference between the crystallization and melting pressure represents the super-compression effect.

## Acknowledgment

Dr. Hertanto Adidharma provided helpful comments, which enhanced this work. Mr. Henry Plancher measured additional data, which helped us confirm the results of this work. This work was supported by a National Science Foundation Grant CTS-9908610 at Louisiana State University.

## Literature Cited

- (1) Chan, A. K.; Hemmingsen, P. V.; Radosz, M. Fluid-Liquid and Fluid-Solid Transitions of Tetracontane in Propane. *J. Chem. Eng. Data* **2000**, *45*, 362–368.
- (2) Chan, A. K.; Russo, P. S.; Radosz, M. Fluid-Liquid Equilibria in Poly(ethylene-co-hexene-1) + Propane: A Light Scattering Probe of Cloud-Point Pressure and Critical Polymer Concentration. *Fluid Phase Equilib.* **2000**, *173*, 149–158.
- (3) Plancher, H. University of Wyoming, personal communication, 2001.
- (4) Plancher, H.; Adidharma, H.; Radosz, M. High-Pressure Crystallization, Melting, and Fluid-Liquid Data for Linear Polyethylene in Propane. *Ind. Eng. Chem. Res.* To be published.
- (5) Łuszczak, M.; Rogalski, M. Universite de Metz, personal communication, 1998.
- (6) Łuszczak, M. Institute of Physical Chemistry Polish Academy of Sciences, personal communication, 2001.

Received for review March 27, 2002. Accepted December 19, 2002.

JE025533X