

**6 $\alpha$ ,7 $\alpha$ -Oxido-17 $\alpha$ -acetoxy-A-norpregn-3-ene-2,20-dione (21).**—A mixture of 15 (320 mg) and *m*-chloroperbenzoic acid (600 mg) in CH<sub>2</sub>Cl<sub>2</sub> (40 ml) was left at room temperature for 66 hr. The CH<sub>2</sub>Cl<sub>2</sub> solution was washed (saturated NaHCO<sub>3</sub>, 5% Na<sub>2</sub>SO<sub>3</sub>, 8% salt solution), dried, and evaporated. Crystallization of the residue from ether-CHCl<sub>3</sub> gave 21 (191 mg, mp 202–204°). The analytical sample was prepared by recrystallization from acetone-hexane; mp 232–233°; [ $\alpha$ ]<sub>D</sub><sup>20</sup> –15° (EtOH);  $\lambda$  5.78, 5.86, and 6.13  $\mu$ ;  $\lambda$  235 m $\mu$  ( $\epsilon$  11,700);  $\tau$  9.28 (s, 18-Me), 8.88 (s, 19-Me), 7.94 (s, 17-OCOC(=O)H), 7.88 (s, 21-Me), 6.61 (d, d,  $J < 1$ , 3.5 cps, 7 $\beta$ -H), 6.18 (d,  $J = 3.5$  cps, 6 $\beta$ -H), 3.78 (s, 3-H).

*Anal.* Calcd for C<sub>22</sub>H<sub>28</sub>O<sub>5</sub>: C, 70.94; H, 7.58. Found: C, 70.97; H, 7.57.

**6 $\alpha$ ,7 $\alpha$ -Oxido-17 $\alpha$ -ethynyl-A-norandrost-3-en-17 $\beta$ -ol-2-one (22).**—A mixture of 17 (1.8 g) and *m*-chloroperbenzoic acid (3.1 g) in CH<sub>2</sub>Cl<sub>2</sub> (150 ml) was left at room temperature for 65 hr. The CH<sub>2</sub>Cl<sub>2</sub> solution was washed (saturated NaHCO<sub>3</sub>, 5% Na<sub>2</sub>SO<sub>3</sub>, 8% salt solution), dried, and evaporated. Plate

chromatography of the residue on neutral alumina (activity V) using CHCl<sub>3</sub> as the developing solvent gave a major band detectable in the ultraviolet. Elution with ethyl acetate, evaporation, and crystallization from ethyl acetate afforded 22 (302 mg, mp 222–224°). The analytical sample was prepared by recrystallization from ethyl acetate; mp 241.5–243.5°; [ $\alpha$ ]<sub>D</sub><sup>20</sup> –79° (CHCl<sub>3</sub>);  $\lambda$  2.97, 3.05, 5.82, 5.97 and 6.17  $\mu$ ;  $\lambda$  234 m $\mu$  ( $\epsilon$  14,300);  $\tau$  9.06 (s, 18-Me), 8.89 (s, 19-Me), 7.43 (s, 17 $\alpha$ -C=H), 6.63 (d,  $J = 3.5$  cps, 7 $\beta$ -H), 6.19 (d,  $J = 3.5$  cps, 6 $\beta$ -H), and 3.79 (s, 3-H).

*Anal.* Calcd for C<sub>22</sub>H<sub>28</sub>O<sub>5</sub>: C, 76.89; H, 7.74. Found: C, 76.43; H, 7.58.

**Acknowledgment.**—We wish to thank Mr. E. Yiakas and Dr. L. Lerner for the biological results, Mr. J. Alicino and his staff for analytical results, and Dr. A. I. Cohen for the nmr data.

## The Synthesis of Hydroxylamine Derivatives Possessing Hypocholesteremic Activity

B. J. LUDWIG, F. DÜRSCH, M. AUERBACH, K. TOMECZEK, AND F. M. BERGER

Wallace Laboratories, Division of Cacter-Wallace, Inc., Cranbury, New Jersey

Received March 3, 1967

The preparation of a variety of O-aralkyl- and O,N-diaralkylhydroxylamine compounds is reported. These include, in addition to the amines, acyl- and aroylhydroxamates, carbalkoxy- and carbaryloxyhydroxamates, and various urea compounds derived from the hydroxylamines. Many of these compounds show significant hypocholesteremic activity upon oral administration to rats. Aralkylation of acetohydroxamic acid is shown to lead to the O,N-diaralkylated rather than O,O'-diaralkylated reaction product. O,N substitution (III) is therefore assumed for the series of analogous acyl- and aroylhydroxamates described.

The biological and pharmacological properties of a large variety of hydroxylamine derivatives have been evaluated in the past. Discovery of the antibacterial properties of canavanine<sup>1</sup> and of cycloserine<sup>2</sup> stimulated the search for antimicrobials containing the oxyamino group. Hydroxylamine derivatives have been reported to possess antibacterial, herbicidal, enzyme inhibiting, and antitumor activities and to have anticonvulsant, analgesic, antirheumatic, diuretic, local anesthetic, hypoglycemic, and CNS stimulating and depressing properties. These reported activities are apparently not necessarily dependent on the hydroxylamine moiety since the corresponding amino analogs frequently exhibit similar activities. In other cases the hydroxylamine function seems to be essential for biological activity. In many investigations these aminoxy compounds have been found to bear little, if any, biological resemblance to their amine counterparts.<sup>3</sup>

We now wish to report the preparation and the results of preliminary pharmacological evaluation of a number of hydroxylamine derivatives that significantly lower the serum cholesterol concentration of warm blooded animals.<sup>4</sup> These compounds consist of aralkoxyamines (I, X = aralkyl; Y = Z = H), N-aralkyl-aralkoxyamines (I, X = Y = aralkyl; Z = H), a

number of the corresponding acyl- and aroylhydroxamates (I, Z = RCO), carbalkoxy- and carbaryloxyhydroxamates (I, Z = ROCO), and urea derivatives (I, Z = CONH<sub>2</sub>, CONHR, CONHCOR). Also included in this study are several related compounds of these types having aryloxyalkyl rather than aralkyl substitution.

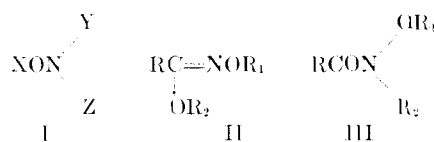

The preparation of these compounds followed in general well-established routes of synthesis (Chart I). Aralkylation of N-hydroxyurethan A with the appropriate aralkyl halides<sup>5a,5,6</sup> furnished good to excellent yields of the aralkyl carbethoxyhydroxamates B or of the corresponding aralkyl N-aralkylcarbethoxyhydroxamates C depending on the ratio of the reactants (reactions 1 and 2). These aralkylations were usually performed in anhydrous ethanol using sodium ethoxide or KOH as acid acceptors. The reactions were exothermic when substituted benzyl bromides were employed, and it was usually possible to obtain good con-

(1) B. E. Volcani and E. E. Snell, *J. Biol. Chem.*, **174**, 893 (1948).

(2) (a) F. A. Kuehl, F. J. Wolf, N. R. Trenner, R. L. Peck, E. Howe, B. D. Hunnewell, G. Downing, E. Newstead, and K. Folkers, *J. Am. Chem. Soc.*, **77**, 2344 (1955); (b) P. H. Hidy, E. B. Hodge, V. V. Young, R. L. Harned, G. A. Brewer, W. F. Phillips, W. F. Runge, H. E. Staveley, A. Pohland, H. Boaz, and H. R. Sullivan, *ibid.*, **77**, 2346 (1955).

(3) (a) For a comprehensive review of the literature on O-substituted oxyamines, see A. O. Ivespää and A. Marner, *Chimia (Aarau)*, **18**, 1 (1964); (b) P. Mammalis, L. Jeffries, S. A. Price, M. J. Rix, and D. J. Outred, *J. Med. Chem.*, **8**, 684 (1965), have summarized the literature dealing with the biological and pharmacological activities of these compounds.

(4) (a) The effect of one of these compounds, benzyl N-benzylcarbethoxyhydroxamate, on experimental atherosclerosis and hypercholesteremia has been described; see F. M. Berger, J. F. Douglas, P. J. Ludwig, and S. Margolin, *Proc. Soc. Exptl. Biol. Med.*, **114**, 337 (1963); J. F. Douglas, B. J. Ludwig, S. Margolin, and F. M. Berger, *J. Atherosclerosis Res.*, **6**, 90 (1966); J. F. Douglas, *Proc. Soc. Exptl. Biol. Med.*, **117**, 190 (1964). (b) F. M. Berger and B. J. Ludwig, U. S. Patents 3,245,878 (April 12, 1966) 3,278,583 (Oct 11, 1966), 3,280,171 (Oct 18, 1966).

(5) A. T. Fuller and H. King, *J. Chem. Soc.*, 963 (1947).

(6) (a) L. W. Jones, *Am. Chem. J.*, **20**, 1 (1898); (b) L. W. Jones and E. E. Fleck, *J. Am. Chem. Soc.*, **50**, 2018 (1928).

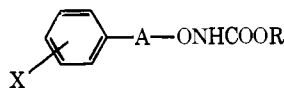
TABLE I  
 ARALKYL CARBALKOXY- AND CARBARYLOXYHYDROXAMATES

No.	X	A	R	Method	Mp or bp		Formula	Calcd, %			Found, %			Activity <sup>a,b</sup>
					(mm), °C	<i>n</i> <sub>D</sub> <sup>20</sup>		C	H	N	C	H	N	
1	H	CH <sub>2</sub>	Methyl	5	109 (0.2)	1.5215	C <sub>9</sub> H <sub>11</sub> NO <sub>3</sub>	59.66	6.12	7.73	59.86	6.09	7.90	
2 <sup>c</sup>	H	CH <sub>2</sub>	Ethyl	1	111 (0.3)	1.5125	C <sub>10</sub> H <sub>13</sub> NO <sub>3</sub>	61.53	6.71	7.18	61.79	6.55	6.97	+ <sup>d</sup>
3	H	CH <sub>2</sub>	Butyl	5	123 (0.8)	1.5023	C <sub>13</sub> H <sub>17</sub> NO <sub>3</sub>	64.55	7.68	6.28	64.27	7.75	6.58	+
4	H	CH <sub>2</sub>	Isobutyl	5	37-38	...	C <sub>12</sub> H <sub>17</sub> NO <sub>3</sub>	64.55	7.68	6.28	64.94	8.01	6.27	+
5	H	CH <sub>2</sub>	Hexyl	5	35	...	C <sub>14</sub> H <sub>21</sub> NO <sub>3</sub>	66.90	8.42	5.58	66.81	8.40	5.89	-
6	H	CH <sub>2</sub>	Phenyl	5	45	...	C <sub>14</sub> H <sub>13</sub> NO <sub>3</sub>	69.12	5.39	5.76	69.22	5.50	5.85	+
7	H	CH <sub>2</sub>	Benzyl	1	65-68	...	C <sub>15</sub> H <sub>15</sub> NO <sub>3</sub>	70.02	5.88	5.44	70.10	5.90	5.49	-
8 <sup>e</sup>	H	(CH <sub>2</sub> ) <sub>2</sub>	Ethyl	1	130 (0.2)	1.5104	C <sub>11</sub> H <sub>15</sub> NO <sub>3</sub>	63.14	7.23	6.70	63.18	6.95	6.82	-
9 <sup>e</sup>	H	(CH <sub>2</sub> ) <sub>3</sub>	Ethyl	1	138 (0.2)	1.5070	C <sub>13</sub> H <sub>17</sub> NO <sub>3</sub>	64.55	7.68	6.28	64.37	7.20	6.46	-
10	<i>m</i> -CH <sub>3</sub>	CH <sub>2</sub>	Ethyl	1	103 (0.1)	1.5138	C <sub>11</sub> H <sub>15</sub> NO <sub>3</sub>	63.14	7.23	6.70	63.47	7.39	6.83	+
11	<i>p</i> -CH <sub>3</sub>	CH <sub>2</sub>	Ethyl	1	45-47	...	C <sub>11</sub> H <sub>15</sub> NO <sub>3</sub>	63.14	7.23	6.70	63.31	7.09	6.76	+ <sup>+</sup>
12	<i>p</i> -CH <sub>3</sub>	(CH <sub>2</sub> ) <sub>3</sub>	Phenyl	5	72-74	...	C <sub>17</sub> H <sub>19</sub> NO <sub>3</sub>	71.56	6.71	4.91	71.65	6.48	5.07	-
13	<i>o</i> -C <sub>2</sub> H <sub>5</sub>	CH <sub>2</sub>	Ethyl	1	120 (0.1)	1.5105	C <sub>12</sub> H <sub>17</sub> NO <sub>3</sub>	64.55	7.68	6.28	64.72	7.66	6.35	+
14	3,4-(CH <sub>3</sub> ) <sub>2</sub>	CH <sub>2</sub>	Ethyl	1	142 (0.1)	1.5152	C <sub>12</sub> H <sub>17</sub> NO <sub>3</sub>	64.55	7.68	6.28	64.42	7.48	6.53	-
15 <sup>f</sup>	<i>iso</i> -Pr	CH <sub>2</sub>	Ethyl	1	133 (0.1)	1.5057	C <sub>13</sub> H <sub>19</sub> NO <sub>3</sub>	65.80	8.07	5.90	65.84	8.10	5.96	-
16	<i>o</i> -OCH <sub>3</sub>	CH <sub>2</sub>	Ethyl	1	127 (0.1)	1.5221	C <sub>11</sub> H <sub>15</sub> NO <sub>4</sub>	58.65	6.72	6.22	58.32	6.17	6.33	-
17 <sup>f</sup>	<i>m</i> -OCH <sub>3</sub>	CH <sub>2</sub>	Ethyl	1	136 (0.2)	1.5186	C <sub>11</sub> H <sub>15</sub> NO <sub>4</sub>	58.65	6.72	6.22	58.31	6.32	6.00	-
18	<i>m</i> -CF <sub>3</sub>	CH <sub>2</sub>	Ethyl	1	78-80	...	C <sub>11</sub> H <sub>13</sub> F <sub>3</sub> NO <sub>3</sub>	50.19	4.60	5.32	50.05	4.69	5.21	+ <sup>g</sup>
19	<i>o</i> -Cl	CH <sub>2</sub>	Ethyl	1	40-42	...	C <sub>10</sub> H <sub>12</sub> ClNO <sub>3</sub>	52.59	5.27	6.10	52.30	5.38	6.33	
20 <sup>h</sup>	<i>p</i> -Cl	CH <sub>2</sub>	Ethyl	1	83-84	...	C <sub>10</sub> H <sub>12</sub> ClNO <sub>3</sub>	52.59	5.27	6.10	52.44	5.51	6.18	+
21 <sup>h</sup>	3,4-Cl <sub>2</sub>	CH <sub>2</sub>	Ethyl	1	80-81	...	C <sub>10</sub> H <sub>11</sub> Cl <sub>2</sub> NO <sub>3</sub>	45.48	4.20	5.30	45.40	4.29	5.22	
22	3,4-Cl <sub>2</sub>	CH(CH <sub>3</sub> )	Ethyl	1	74-75	...	C <sub>11</sub> H <sub>13</sub> Cl <sub>2</sub> NO <sub>3</sub>	47.50	4.71	5.04	47.47	4.55	5.01	
23	<i>p</i> -NO <sub>2</sub>	CH <sub>2</sub>	Ethyl	1	82	...	C <sub>10</sub> H <sub>12</sub> N <sub>2</sub> O <sub>5</sub>	50.00	5.04	11.66	50.17	4.92	11.50	+
24	<i>p</i> -NH <sub>2</sub>	CH <sub>2</sub>	Ethyl	<i>i</i>	133, dec	...	C <sub>10</sub> H <sub>15</sub> ClN <sub>2</sub> O <sub>2</sub> <sup>i</sup>	48.68	6.12	11.36	48.53	5.87	11.59	-

<sup>a</sup> The activity is measured as a reduction of serum cholesterol relative to control animals on the same diet without drug: <25% reduction = -, 25-50% reduction = +, 51-75% reduction = ++, and 76% or greater reduction = ++++. <sup>b</sup> At 0.5% diet level. <sup>c</sup> A. Hantzsch and A. Sauer, *Ann. Chem.*, **299**, 67 (1897). <sup>d</sup> At 1.0% diet level. <sup>e</sup> See ref 7c. <sup>f</sup> See ref 3a. <sup>g</sup> At 0.25% diet level. <sup>h</sup> A. F. McKay, D. L. Garmaise, G. Y. Paris, and S. Gelblum, *Can. J. Chem.*, **38**, 343 (1960). <sup>i</sup> See Experimental Section. <sup>j</sup> Hydrochloride.

CHART I

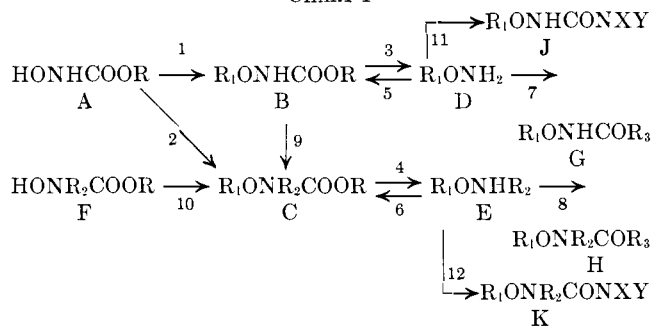

versions at room temperature. Benzyl chlorides and higher aralkyl halides usually required several hours of reflux for completion of the reaction. Small quantities of the corresponding ethyl ethers were always obtained as by-products, these ethers being formed by aralkylation of the alcoholic solvent. These lower boiling ethers could be readily separated from the reaction mixture by distillation. A 1:1 molar ratio of aralkylating agent to N-hydroxyurethan furnished good yields of the O-aralkylated products of type B with little of the O,N-diaralkylated compound of type C. Increasing amounts of C were obtained by increasing this ratio and C was formed almost exclusively when the ratio of aralkylating agent to N-hydroxyurethan was 2:1. This procedure is preferred when carbethoxyhydroxamate compounds containing two identical aralkyl groups are desired. A molar ratio of 1.5:1 was usually employed when both B and C were desired. The products could then be separated either by fractional distillation or, following the procedure of Jones,<sup>6</sup> by extracting the O-aralkylated product into aqueous alkali, the

O,N-diaralkyl derivative remaining in the organic layer.

The majority of the carbethoxyhydroxamates so prepared are high-boiling colorless oils. They were purified by vacuum distillation except in a few cases where molecular distillation was employed when extensive decomposition occurred using conventional high-vacuum distillation apparatus. The physical constants and the analytical data for the aralkyl carbethoxyhydroxamates and aralkyl N-aralkylcarbethoxyhydroxamates are listed in Tables I and II, respectively. Similar data for a smaller number of aryloxyalkyl derivatives are included in Tables III and IV.

The hydrolysis of carbethoxyhydroxamates of types B and C with alkali<sup>3a,5,6</sup> produced excellent yields of the corresponding aralkoxyamines of type D or of N-aralkylaralkoxyamines of type E (reactions 3 and 4). It was generally unnecessary to isolate the intermediate carbethoxyhydroxamates when these hydroxylamines were the desired compounds. The reaction mixture from reactions 1 or 2 was treated with aqueous alkali and the hydroxylamines were obtained directly. These weakly basic compounds were usually high-boiling colorless liquids which can be purified by vacuum distillation or by conversion to the hydrochlorides which can be readily crystallized from alcohol. The physical constants and the analytical data for these aralkylated hydroxylamines are listed in Tables V and VI. Tables III and IV include a smaller number of the corresponding aryloxyalkylated hydroxylamines.

It has been reported by a number of investigators that certain of the aralkoxyamine hydrochlorides of this general type decompose on standing to HCl and the

TABLE II  
ARALKYL, N-ARALKYLCARBALKOXY- AND -CARBARYLOXYHYDROXAMATES

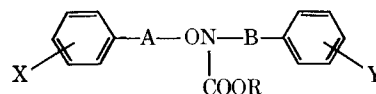

No.	X	A	Y	B	R	Method	Mp or bp (mm), °C	$n_D^{25}$	Formula	Caled. %			Found. %			Activity <sup>a</sup>
										C	H	N	C	H	N	
47 <sup>b</sup>	H	CH <sub>2</sub>	H	CH <sub>2</sub>	Ethyl	2	145 (0.3)	1.5402	C <sub>17</sub> H <sub>19</sub> NO <sub>3</sub>	71.55	6.71	4.91	71.37	6.78	5.04	+++ <sup>c</sup>
48	H	CH <sub>2</sub>	H	CH <sub>2</sub>	$\beta$ -Methoxyethyl	6	173 (0.3)	1.5362	C <sub>18</sub> H <sub>21</sub> NO <sub>4</sub>	68.55	6.71	4.44	68.93	6.68	4.56	++
49	H	CH <sub>2</sub>	H	CH <sub>2</sub>	$\gamma$ -Methoxypropyl	6	178 (0.1)	1.5308	C <sub>19</sub> H <sub>23</sub> NO <sub>4</sub>	69.28	7.04	4.25	69.50	7.20	4.20	-
50	H	CH <sub>2</sub>	H	CH <sub>2</sub>	Isobutyl	6	144 (0.1)	1.5281	C <sub>19</sub> H <sub>23</sub> NO <sub>3</sub>	72.82	7.40	4.47	73.11	7.07	4.72	++
51	H	CH <sub>2</sub>	H	CH <sub>2</sub>	Phenyl	6	59-61	...	C <sub>21</sub> H <sub>19</sub> NO <sub>3</sub>	75.65	5.72	4.21	75.62	5.84	4.11	++
52	H	CH <sub>2</sub>	H	CH(CH <sub>3</sub> )	Ethyl	9	135 (0.1)	1.5362	C <sub>18</sub> H <sub>21</sub> NO <sub>3</sub>	72.22	7.07	4.68	72.36	7.04	4.56	-
53	H	CH(CH <sub>3</sub> )	H	CH <sub>2</sub>	Ethyl	10	132 (0.1)	1.5355	C <sub>18</sub> H <sub>21</sub> NO <sub>3</sub>	72.22	7.07	4.68	72.31	7.07	4.59	++
54	H	CH <sub>2</sub>	H	(CH <sub>2</sub> ) <sub>2</sub>	Ethyl	9	146 (0.1)	1.5354	C <sub>18</sub> H <sub>21</sub> NO <sub>3</sub>	72.22	7.07	4.68	72.13	7.11	4.71	++
55	H	(CH <sub>2</sub> ) <sub>3</sub>	H	CH <sub>2</sub>	Ethyl	9	153 (0.1)	1.5326	C <sub>19</sub> H <sub>23</sub> NO <sub>3</sub>	72.82	7.40	4.47	73.16	7.40	4.59	++
56	H	CH <sub>2</sub>	H	(CH <sub>2</sub> ) <sub>3</sub>	Ethyl	9	157 (0.1)	1.5324	C <sub>19</sub> H <sub>23</sub> NO <sub>3</sub>	72.82	7.40	4.47	72.36	6.96	4.80	+++
57	H	(CH <sub>2</sub> ) <sub>3</sub>	H	(CH <sub>2</sub> ) <sub>3</sub>	Ethyl	2	182 (0.2)	1.5284	C <sub>21</sub> H <sub>27</sub> NO <sub>3</sub>	73.87	7.97	4.10	73.90	8.05	4.22	++
58	H	CH <sub>2</sub>	H	(CH <sub>2</sub> ) <sub>3</sub>	$\beta$ -Methoxyethyl	6	<i>d</i>	1.5301	C <sub>20</sub> H <sub>25</sub> NO <sub>4</sub>	69.95	7.34	4.08	69.91	7.37	4.13	++
59	H	CH <sub>2</sub>	<i>o</i> -CH <sub>3</sub>	CH <sub>2</sub>	Ethyl	9	<i>d</i>	1.5375	C <sub>18</sub> H <sub>21</sub> NO <sub>3</sub>	72.22	7.07	4.68	71.96	7.25	4.95	++
60	H	CH <sub>2</sub>	<i>m</i> -CH <sub>3</sub>	CH <sub>2</sub>	Ethyl	9	136 (0.1)	1.5362	C <sub>18</sub> H <sub>21</sub> NO <sub>3</sub>	72.22	7.07	4.68	72.36	7.24	4.75	++
61	<i>o</i> -CH <sub>3</sub>	CH <sub>2</sub>	H	CH <sub>2</sub>	Ethyl	10	142 (0.1)	1.5405	C <sub>18</sub> H <sub>21</sub> NO <sub>3</sub>	72.22	7.07	4.68	72.07	6.97	4.87	-
62	<i>m</i> -CH <sub>3</sub>	CH <sub>2</sub>	H	CH <sub>2</sub>	Ethyl	10	139 (0.1)	1.5376	C <sub>18</sub> H <sub>21</sub> NO <sub>3</sub>	72.22	7.07	4.68	72.18	6.95	4.71	++
63	<i>m</i> -CH <sub>3</sub>	CH <sub>2</sub>	H	(CH <sub>2</sub> ) <sub>3</sub>	Ethyl	9	167 (0.1)	1.5315	C <sub>20</sub> H <sub>25</sub> NO <sub>3</sub>	73.37	7.70	4.28	73.81	7.55	4.30	++
64	<i>o</i> -CH <sub>3</sub>	CH <sub>2</sub>	<i>o</i> -CH <sub>3</sub>	CH <sub>2</sub>	Methyl	6	<i>d</i>	1.5483	C <sub>18</sub> H <sub>21</sub> NO <sub>3</sub>	72.22	7.07	4.68	71.99	6.98	4.99	-
65	<i>o</i> -CH <sub>3</sub>	CH <sub>2</sub>	<i>o</i> -CH <sub>3</sub>	CH <sub>2</sub>	Ethyl	2	143 (0.1)	1.5401	C <sub>19</sub> H <sub>23</sub> NO <sub>3</sub>	72.82	7.40	4.47	72.97	7.72	4.96	++
66	<i>m</i> -CH <sub>3</sub>	CH <sub>2</sub>	<i>m</i> -CH <sub>3</sub>	CH <sub>2</sub>	Ethyl	2	146 (0.1)	1.5361	C <sub>19</sub> H <sub>23</sub> NO <sub>3</sub>	72.82	7.40	4.47	73.48	7.54	4.72	+++
67	<i>p</i> -CH <sub>3</sub>	CH <sub>2</sub>	<i>p</i> -CH <sub>3</sub>	CH <sub>2</sub>	Ethyl	2	137 (0.1)	1.5340	C <sub>19</sub> H <sub>23</sub> NO <sub>3</sub>	72.82	7.40	4.47	72.90	7.68	4.72	+
68	3,4-(CH <sub>3</sub> ) <sub>2</sub>	CH <sub>2</sub>	3,4-(CH <sub>3</sub> ) <sub>2</sub>	CH <sub>2</sub>	Ethyl	2	175 (0.1)	1.5399	C <sub>21</sub> H <sub>27</sub> NO <sub>3</sub>	73.87	7.97	4.10	73.94	7.75	-	++
69	<i>o</i> -C <sub>2</sub> H <sub>5</sub>	CH <sub>2</sub>	<i>o</i> -C <sub>2</sub> H <sub>5</sub>	CH <sub>2</sub>	Ethyl	2	<i>d</i>	1.5303	C <sub>21</sub> H <sub>27</sub> NO <sub>3</sub>	73.87	7.97	4.10	73.65	7.81	4.32	+++
70	<i>p</i> - <i>i</i> -C <sub>3</sub> H <sub>7</sub>	CH <sub>2</sub>	<i>p</i> - <i>i</i> -C <sub>3</sub> H <sub>7</sub>	CH <sub>2</sub>	Ethyl	2	<i>d</i>	1.5229	C <sub>23</sub> H <sub>31</sub> NO <sub>3</sub>	74.76	8.46	3.79	74.39	8.51	4.06	++
71	<i>p</i> -CH <sub>3</sub>	(CH <sub>2</sub> ) <sub>3</sub>	<i>m</i> -CH <sub>3</sub>	CH <sub>2</sub>	Phenyl	6	<i>d</i>	1.5606	C <sub>25</sub> H <sub>27</sub> NO <sub>3</sub>	77.09	6.99	3.60	77.05	7.23	3.80	-
72	<i>o</i> -OCH <sub>3</sub>	CH <sub>2</sub>	<i>o</i> -OCH <sub>3</sub>	CH <sub>2</sub>	Ethyl	2	<i>d</i>	1.5478	C <sub>19</sub> H <sub>23</sub> NO <sub>3</sub>	66.07	6.71	4.06	66.00	6.89	4.21	-
73	<i>m</i> -OCH <sub>3</sub>	CH <sub>2</sub>	<i>m</i> -OCH <sub>3</sub>	CH <sub>2</sub>	Ethyl	2	<i>d</i>	1.5435	C <sub>19</sub> H <sub>23</sub> NO <sub>3</sub>	66.07	6.71	4.06	66.10	6.82	4.24	+
74	<i>p</i> -OCH <sub>3</sub>	CH <sub>2</sub>	<i>p</i> -OCH <sub>3</sub>	CH <sub>2</sub>	Ethyl	2	<i>d</i>	1.5436	C <sub>19</sub> H <sub>23</sub> NO <sub>3</sub>	66.07	6.71	4.06	66.17	6.94	4.61	+
75	2,6-(OCH <sub>3</sub> ) <sub>2</sub>	CH <sub>2</sub>	2,6-(OCH <sub>3</sub> ) <sub>2</sub>	CH <sub>2</sub>	Ethyl	2	89-90	...	C <sub>21</sub> H <sub>27</sub> NO <sub>3</sub>	62.21	6.71	3.46	62.23	6.19	3.37	-
76	<i>o</i> -OC <sub>2</sub> H <sub>5</sub>	CH <sub>2</sub>	<i>o</i> -OC <sub>2</sub> H <sub>5</sub>	CH <sub>2</sub>	Ethyl	2	48-50	...	C <sub>21</sub> H <sub>27</sub> NO <sub>3</sub>	67.35	7.26	3.73	67.61	7.04	3.75	-
77	H	CH <sub>2</sub>	<i>o</i> -COOC <sub>2</sub> H <sub>5</sub>	CH <sub>2</sub>	Ethyl	9	<i>d</i>	1.5362	C <sub>20</sub> H <sub>25</sub> NO <sub>5</sub>	67.21	6.49	3.92	66.91	6.35	4.21	-
78	<i>m</i> -CF <sub>3</sub>	CH <sub>2</sub>	<i>m</i> -CF <sub>3</sub>	CH <sub>2</sub>	Ethyl	2	126 (0.2)	1.4707	C <sub>19</sub> H <sub>17</sub> F <sub>6</sub> NO <sub>3</sub>	54.16	4.07	3.33	54.40	4.20	3.60	++
79	<i>o</i> -Cl	CH <sub>2</sub>	<i>o</i> -Cl	CH <sub>2</sub>	Ethyl	2	146 (0.1)	1.5562	C <sub>17</sub> H <sub>17</sub> Cl <sub>2</sub> NO <sub>3</sub> <sup>e</sup>	57.64	4.84	3.95	57.64	4.73	4.03	-
80	<i>p</i> -Cl	CH <sub>2</sub>	<i>p</i> -Cl	CH <sub>2</sub>	Ethyl	2	171 (0.1)	1.5538	C <sub>17</sub> H <sub>17</sub> Cl <sub>2</sub> NO <sub>3</sub> <sup>f</sup>	57.64	4.84	3.95	57.71	5.08	4.00	+++
81	<i>p</i> -Cl	CH <sub>2</sub>	<i>p</i> -Cl	CH <sub>2</sub>	Phenyl	6	84-87	...	C <sub>21</sub> H <sub>17</sub> Cl <sub>2</sub> NO <sub>3</sub>	62.70	4.26	<i>g</i>	62.90	4.31	-	-
82	<i>p</i> -NO <sub>2</sub>	CH <sub>2</sub>	<i>p</i> -NO <sub>2</sub>	CH <sub>2</sub>	Ethyl	2	105-106	...	C <sub>17</sub> H <sub>17</sub> N <sub>3</sub> O <sub>7</sub>	54.40	4.57	11.19	54.40	4.51	11.25	-

<sup>a</sup> At 0.25% diet level. See footnote *a*, Table I, for a description of the activity data. <sup>b</sup> See ref 6b. <sup>c</sup> At 0.5% diet level. <sup>d</sup> These compounds were purified by short-path distillation at 100-120° bath temperature (0.001 mm) since decomposition occurred in attempts to use conventional equipment. <sup>e</sup> *Anal.* Calcd: Cl, 20.02. Found: Cl, 20.24. <sup>f</sup> *Anal.* Calcd: Cl, 20.02. Found: Cl, 20.16. <sup>g</sup> *Anal.* Calcd: Cl, 17.63. Found: Cl, 18.23.

TABLE III  
ARALKOXY-N-ARYLOXYALKYLAMINES AND ARALKYL N-ARYLOXYALKYLHYDROXAMATES

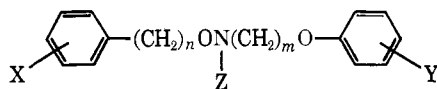

No.	X	n	Y	m	Z	Method	Mp or bp (mm), °C	n <sub>D</sub> <sup>20</sup>	Formula	Calcd. %			Found. %			Activity <sup>a</sup>
										C	H	N	C	H	N	
147	H	1	H	2	H	4	121-122	...	C <sub>18</sub> H <sub>18</sub> ClNO <sub>2</sub> <sup>b</sup>	64.40	6.48	5.01	64.26	6.39	4.95	++
148	H	1	m-CH <sub>3</sub>	2	H	4	145 (0.1)	1.5532	C <sub>18</sub> H <sub>19</sub> NO <sub>2</sub>	74.68	7.44	5.44	74.64	7.44	5.73	++
149	H	1	H	3	H	4	103-104	...	C <sub>18</sub> H <sub>20</sub> ClNO <sub>2</sub> <sup>b</sup>	65.41	6.86	4.77	65.96	7.01	4.90	+++
150	m-CH <sub>3</sub>	1	H	3	H	1, 9, 4	84-86	...	C <sub>17</sub> H <sub>22</sub> ClNO <sub>2</sub> <sup>b</sup>	66.33	7.20	4.55	66.06	7.45	4.25	+++
151	p-Cl	1	H	3	H	1, 9, 4	c	1.5610	C <sub>18</sub> H <sub>18</sub> ClNO <sub>2</sub> <sup>d</sup>	65.86	6.22	4.80	65.83	6.16	4.88	++
152	m-CH <sub>3</sub>	1	H	4	H	1, 9, 4	119-120	...	C <sub>18</sub> H <sub>24</sub> ClNO <sub>2</sub> <sup>b</sup>	67.17	7.52	4.35	67.48	7.67	4.45	+++
153	m-CH <sub>3</sub>	1	p-Cl	3	H	1, 9, 4	133-134	...	C <sub>17</sub> H <sub>21</sub> Cl <sub>2</sub> NO <sub>2</sub> <sup>b, e</sup>	59.65	6.18	4.09	59.54	6.40	4.15	++
154	H	3	2,4-Cl <sub>2</sub>	2	H	1, 9, 4	147-148	...	C <sub>17</sub> H <sub>20</sub> Cl <sub>2</sub> NO <sub>2</sub> <sup>b, f</sup>	54.20	5.35	3.72	54.12	5.24	3.78	++
155	H	1	H	2	COOC <sub>2</sub> H <sub>5</sub>	1, 9	162 (0.1)	1.5379	C <sub>18</sub> H <sub>21</sub> NO <sub>4</sub>	68.55	6.71	4.44	68.22	6.51	4.48	+++
156	H	1	H	3	COOC <sub>2</sub> H <sub>5</sub>	1, 9	168 (0.1)	1.5345	C <sub>19</sub> H <sub>23</sub> NO <sub>4</sub>	69.28	7.04	4.25	69.41	7.04	4.46	++
157	H	1	m-CH <sub>3</sub>	2	COOC <sub>2</sub> H <sub>5</sub>	1, 9	172 (0.1)	1.5342	C <sub>19</sub> H <sub>23</sub> NO <sub>4</sub>	69.28	7.04	4.25	69.37	7.20	4.50	+++
158	H	1	m-CH <sub>3</sub>	2	COOC <sub>2</sub> H <sub>5</sub>	6	c	1.5690	C <sub>23</sub> H <sub>28</sub> NO <sub>4</sub>	73.19	6.14	3.71	73.35	6.03	3.93	++
159	m-CH <sub>3</sub>	1	p-Cl	3	COOCH <sub>3</sub>	6	c	1.5465	C <sub>19</sub> H <sub>22</sub> ClNO <sub>4</sub> <sup>g</sup>	62.73	6.09	3.85	62.89	6.83	3.86	++
160	H	1	m-CH <sub>3</sub>	2	COC <sub>2</sub> H <sub>5</sub>	8	c	1.5812	C <sub>23</sub> H <sub>28</sub> NO <sub>3</sub>	76.43	6.41	3.87	76.39	6.34	4.03	++
161	m-CH <sub>3</sub>	1	H	4	COCH <sub>3</sub>	8	c	1.5454	C <sub>20</sub> H <sub>26</sub> NO <sub>3</sub>	73.36	7.70	4.28	73.39	7.58	4.27	+

<sup>a</sup> At 0.25% diet level. See footnote a, Table I, for a description of the activity data. <sup>b</sup> Hydrochloride. <sup>c</sup> These compounds were purified by short-path distillation at 100-120° bath temperature (0.001 mm) since decomposition occurred in attempts to use conventional equipment. <sup>d</sup> Anal. Calcd: Cl, 12.15. Found: Cl, 12.33. <sup>e</sup> Anal. Calcd: Cl, 20.72. Found: Cl, 20.70. <sup>f</sup> Anal. Calcd: Cl, 28.23. Found: Cl, 28.15. <sup>g</sup> Anal. Calcd: Cl, 9.74. Found: Cl, 9.89.

free amine.<sup>3a,7</sup> The arylmethoxy-, aryloxy-, and arylpropoxyamine hydrochlorides prepared in this study appeared to be reasonably stable on prolonged standing at room temperature. In a few instances, a mild aldehydic odor was perceptible, but no further evidence of instability was apparent. A few of the corresponding aryloxyalkoxyamine hydrochlorides [ArO-(CH<sub>2</sub>)<sub>n</sub>ONH<sub>2</sub>·HCl], however, underwent more extensive dissociation when stored at room temperature for periods of a year or longer, generating free HCl and a strong aldehydic odor.

The reaction of these hydroxylamines with alkyl and aryl chloroformates using excess hydroxylamine, pyridine, or aqueous alkali as acid acceptor yielded the corresponding carbalkoxy- and carbaryloxyhydroxamates (reactions 5 and 6). This route was followed advantageously when products having carbaryloxy groups and carbalkoxy groups other than carbethoxy were desired.

Acylation of the aralkylated hydroxylamines of type D and E with the appropriate acid chloride or anhydride produced the corresponding acyl- and aroylhydroxamates of type G and H in excellent yields (reactions 7 and 8). Formylations were performed by heating the amine hydrochlorides with formamide as reported by Galat and Elion.<sup>8</sup> These aralkylated acyl- and aroylhydroxamates are generally low-melting solids or high-boiling colorless oils. They were purified by recrystallization, vacuum distillation, or molecular distillation. Their physical constants and analytical data are listed in Tables VII and VIII. The corresponding aryloxyalkyl derivatives are included among the compounds listed in Tables III and IV.

Some uncertainty remains in the chemical literature concerning the structure of dialkylated hydroxamic acids. Frequently, structure II has been assigned

to the reported compounds,<sup>9,10</sup> while the alternate structure III has been less often used. The former structure appears to be excluded for compounds of type H by the method of preparation. Cooley, *et al.*,<sup>10</sup> reported the preparation of a dibenzylated product from aceto-hydroxamic acid and benzyl chloride but did not report any attempt to ascertain its correct structure. Using their method, we obtained a product having the properties described by them and which was identical with the compound we obtained from the reaction of O,N-dibenzylhydroxylamine with acetyl chloride. Thus, it appears that in the series of compounds studied by us the diaralkylation of hydroxamic acids leads to compounds of structure III rather than II.<sup>11</sup>

Aralkylated hydroxylamines of type D and E were readily converted to the corresponding urea derivatives of type J and K by direct action with cyanic acid and with alkyl or acyl isocyanates. These compounds were obtained in high yields and were readily crystallizable from ligroin, alcohol, or water to give stable, sharp-melting, colorless, crystalline solids (Table IX).

The preparation of compounds of types C, E, or H where R<sub>1</sub> ≠ R<sub>2</sub>, *i.e.*, "unsymmetric" compounds, was accomplished in two general ways. The alkylation of the carbethoxyhydroxamates of type B<sup>7c</sup> with aralkyl halides under the conditions employed for reaction 2 produced high yields of the desired compounds of type C (reaction 9). Alternately, N-aralkylcarbethoxyhydroxamic acids of type F were prepared from N-aralkylhydroxylamines and ethyl chloroformate, following the procedure described by Zinner<sup>12</sup> for the preparation of the corresponding N-alkylcarbethoxyhydroxamates. Alkylation with the appropriate aralkyl halides

(9) H. L. Yale, *Chem. Rev.*, **33**, 209 (1944).

(10) J. H. Cooley, W. D. Bills, and J. R. Throckmorton, *J. Org. Chem.*, **25**, 1734 (1960).

(11) (a) G. M. Steinberg and R. Swidler, *ibid.*, **30**, 2362 (1965), have presented evidence for the existence and relative reactivities of the various benzohydroxamate anions. (b) For a discussion of the mechanism of reactions involved in the synthesis and hydrolysis of N-hydroxycarbamates, see E. Boyland and R. Nery, *J. Chem. Soc., Sect. C*, 346 (1966).

(12) G. Zinner, *Arch. Pharm.*, **292**, 329 (1959).

(7) (a) R. T. Major and K. W. Ohly, *J. Med. Pharm. Chem.*, **4**, 51 (1961); (b) P. Mamalis, J. Green, D. J. Outred, and M. J. Rix, *J. Chem. Soc.*, 1829 (1965); (c) B. J. R. Nicolaus, G. Pagani, and E. Testa, *Helv. Chim. Acta*, **45**, 1381 (1962).

(8) A. Galat and C. Elion, *J. Am. Chem. Soc.*, **65**, 1566 (1943).

TABLE IV: ARYLOXYALKOXYAMINES AND ARYLOXYALKYL HYDROXAMINES

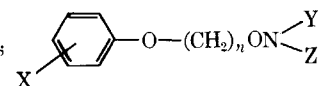

No.	X	n	Y	Z	Method	Mp or bp (mm), °C	n <sub>D</sub> <sup>20</sup>	Formula	Calcd. %			Found. %			Activity <sup>a</sup>
									C	H	N	C	H	N	
162 <sup>b</sup>	2,4-Cl <sub>2</sub>	2	H	H	3	183-184	...	C <sub>9</sub> H <sub>10</sub> Cl <sub>2</sub> NO <sub>2</sub> <sup>d</sup>	37.16	3.90	5.42	37.19	3.89	5.50	
163	H	3	H	H	3	118-120	...	C <sub>9</sub> H <sub>10</sub> ClNO <sub>2</sub> <sup>e</sup>	53.07	6.93	6.88	53.12	7.03	7.04	+
164 <sup>b</sup>	2,4-Cl <sub>2</sub>	2	H	COOC <sub>2</sub> H <sub>5</sub>	1	67-68	...	C <sub>11</sub> H <sub>13</sub> Cl <sub>2</sub> NO <sub>4</sub> <sup>e</sup>	44.92	4.46	4.76	45.02	4.38	4.88	+
165	H	3	H	COOCH <sub>3</sub>	1	63-70	...	C <sub>11</sub> H <sub>15</sub> NO <sub>4</sub>	58.65	6.71	6.22	58.77	6.72	6.22	
166	H	3	H	COOC <sub>2</sub> H <sub>5</sub>	1	43-46	...	C <sub>12</sub> H <sub>17</sub> NO <sub>4</sub>	60.23	7.16	5.85	60.68	7.14	5.76	
167	H	3	H	COOC <sub>6</sub> H <sub>5</sub>	7	f	1.5739	C <sub>16</sub> H <sub>17</sub> NO <sub>3</sub>	70.83	6.32	5.16	70.72	6.19	5.11	
168	m-CH <sub>3</sub>	2	Benzyl	H	9, 4	g	...	C <sub>16</sub> H <sub>20</sub> ClNO <sub>2</sub> <sup>e</sup>	65.41	6.86	4.76	65.30	6.93	4.78	-
169	2,4-Cl <sub>2</sub>	2	m-Methylbenzyl	H	9, 4	94-96	...	C <sub>16</sub> H <sub>18</sub> Cl <sub>2</sub> NO <sub>2</sub> <sup>e,h</sup>	52.99	5.00	3.86	52.79	5.00	4.45	
170	H	3	Benzyl	H	9, 4	117-119	...	C <sub>16</sub> H <sub>20</sub> ClNO <sub>2</sub> <sup>e</sup>	65.42	6.86	4.77	65.58	6.79	5.04	++
171	m-CH <sub>3</sub>	3	Benzyl	H	4	g	1.5510	C <sub>17</sub> H <sub>21</sub> NO <sub>2</sub>	75.24	7.80	5.16	74.97	7.66	5.25	
172	p-Cl	3	Benzyl	H	1, 9, 4	116-118	...	C <sub>16</sub> H <sub>19</sub> Cl <sub>2</sub> NO <sub>2</sub> <sup>e,i</sup>	58.54	5.83	4.27	58.67	5.76	4.26	+++
173	H	3	γ-Phenoxypropyl	H	2, 4	100-102	...	C <sub>18</sub> H <sub>24</sub> ClNO <sub>3</sub> <sup>e</sup>	63.99	7.16	4.15	64.14	7.22	4.16	++
174	H	2	Benzyl	COOC <sub>2</sub> H <sub>5</sub>	9	163 (0.1)	1.5388	C <sub>18</sub> H <sub>21</sub> NO <sub>4</sub>	68.55	6.71	4.44	68.47	7.06	4.39	+
175	2,4-Cl <sub>2</sub>	2	2,4-Cl <sub>2</sub> -Phenoxyethyl	COOC <sub>2</sub> H <sub>5</sub>	2	64-65	...	C <sub>19</sub> H <sub>19</sub> Cl <sub>2</sub> NO <sub>3</sub> <sup>e,j</sup>	47.23	3.96	2.90	47.35	3.69	2.42	-
176	H	3	γ-Phenylpropyl	COOCH <sub>3</sub>	9	g	1.5332	C <sub>20</sub> H <sub>25</sub> NO <sub>4</sub>	69.95	7.34	4.08	69.98	7.17	4.05	+++
177	H	3	Benzyl	COOC <sub>2</sub> H <sub>5</sub>	9	167 (0.1)	1.5335	C <sub>19</sub> H <sub>23</sub> NO <sub>4</sub>	69.28	7.04	4.25	69.32	6.75	4.23	+
178	m-CH <sub>3</sub>	3	Benzyl	COOC <sub>2</sub> H <sub>5</sub>	9	167 (0.05)	1.5312	C <sub>20</sub> H <sub>25</sub> NO <sub>4</sub>	69.95	7.34	4.08	70.03	7.33	3.84	+
179	H	3	α-Phenethyl	COOCH <sub>3</sub>	4, 8	41-43	...	C <sub>19</sub> H <sub>23</sub> NO <sub>3</sub>	72.82	7.40	4.47	72.73	7.25	4.42	
180	p-Cl	3	Benzyl	COCH <sub>3</sub>	8	g	1.5565	C <sub>18</sub> H <sub>20</sub> ClNO <sub>3</sub> <sup>k</sup>	64.76	6.04	4.19	64.77	6.09	4.17	+++

<sup>a</sup> At 0.25% diet level. See footnote a, Table I, for a description of the activity data. <sup>b</sup> See ref 3a. <sup>c</sup> Hydrochloride. <sup>d</sup> Anal. Calcd: Cl, 41.14. Found: Cl, 41.20. <sup>e</sup> Anal. Calcd: Cl, 24.11. Found: Cl, 24.16. <sup>f</sup> Undistillable oil. <sup>g</sup> These compounds were purified by short-path distillation at 100-120° bath temperature (0.001 mm) since decomposition occurred in attempts to use conventional equipment. <sup>h</sup> Anal. Calcd: Cl, 29.33. Found: Cl, 29.23. <sup>i</sup> Anal. Calcd: Cl, 21.60. Found: Cl, 21.61. <sup>j</sup> Anal. Calcd: Cl, 29.35. Found: Cl, 29.42. <sup>k</sup> Anal. Calcd: Cl, 10.62. Found: Cl, 10.83.

TABLE V: ARALKOXYAMINES

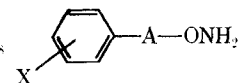

No.	X	A	Mp or bp (mm), °C	n <sub>D</sub> <sup>20</sup>	Formula	Calcd. %			Found. %			Activity <sup>a</sup>
						C	H	N	C	H	N	
25 <sup>b</sup>	H	CH <sub>2</sub>	230-232	...	C <sub>7</sub> H <sub>10</sub> ClNO <sup>e</sup>	52.67	6.32	8.78	53.13	6.51	8.60	
26 <sup>d</sup>	H	CH(CH <sub>3</sub> )	156-158	...	C <sub>8</sub> H <sub>12</sub> ClNO <sup>e</sup>	55.33	6.96	8.07	55.30	7.05	8.26	-
27	m-CH <sub>3</sub>	CH <sub>2</sub>	52 (0.4)	1.5336	C <sub>8</sub> H <sub>11</sub> NO	70.04	8.08	10.21	70.07	8.19	10.07	+
28	p-CH <sub>3</sub>	(CH <sub>2</sub> ) <sub>2</sub>	63 (0.1)	1.5202	C <sub>10</sub> H <sub>15</sub> NO	72.69	9.15	8.48	72.63	8.75	8.39	
29 <sup>e</sup>	m-OC <sub>11</sub> H <sub>23</sub>	CH <sub>2</sub>	75 (0.4)	1.5439	C <sub>5</sub> H <sub>11</sub> NO <sub>2</sub>	62.72	7.24	9.14	63.01	7.13	9.05	+
30	2,6-(OC <sub>11</sub> H <sub>23</sub> ) <sub>2</sub>	CH <sub>2</sub>	177-178	...	C <sub>9</sub> H <sub>14</sub> ClNO <sub>3</sub> <sup>e</sup>	49.21	6.42	6.38	49.56	6.69	6.26	-
31	m-CF <sub>3</sub>	CH <sub>2</sub>	164-165	...	C <sub>8</sub> H <sub>9</sub> ClF <sub>3</sub> NO <sup>e</sup>	42.21	3.98	6.15	42.41	4.14	5.94	+
32 <sup>f</sup>	o-Cl	CH <sub>2</sub>	143-145	...	C <sub>7</sub> H <sub>9</sub> Cl <sub>2</sub> NO <sup>e</sup>	43.32	4.68	7.22	43.52	5.26	7.49	+
33 <sup>g</sup>	p-Cl	CH <sub>2</sub>	40	...	C <sub>7</sub> H <sub>9</sub> ClNO	53.34	5.12	8.89	53.17	5.10	8.88	++
34 <sup>h</sup>	3,4-Cl <sub>2</sub>	CH <sub>2</sub>	191-192	...	C <sub>7</sub> H <sub>9</sub> Cl <sub>2</sub> NO <sup>e</sup>	36.79	3.53	6.13	36.76	3.45	5.93	
35	p-NH <sub>2</sub>	CH <sub>2</sub>	100 (0.2)	1.6048	C <sub>7</sub> H <sub>10</sub> N <sub>2</sub> O	60.85	7.30	20.28	60.75	7.46	20.38	-

<sup>a</sup> At 0.5% diet level. See footnote a, Table I, for a description of the activity data. <sup>b</sup> A. Janny, *Ber.*, **16**, 170 (1883). <sup>c</sup> Hydrochloride. <sup>d</sup> See ref 7c. <sup>e</sup> Ilyespiä and Marxer<sup>3a</sup> reported hydrochloride mp 126-128°. <sup>f</sup> See ref 3a. <sup>g</sup> E. L. Schumann, R. V. Heinzelman, M. E. Greig, and W. Veldkamp, *J. Med. Chem.*, **7**, 329 (1964), reported hydrochloride mp 245° dec. <sup>h</sup> McKay, *et al.* (Table I, footnote g), reported mp 195-198° dec.

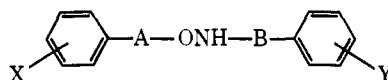
TABLE VI  
 N-ARALKYLARALKOXYAMINES

No.	X	A	Y	B	Mp or bp (mm), °C	$n_{25}^D$	Formula	Calcd. %			Found. %			Activity <sup>a</sup>
								C	H	N	C	H	N	
83 <sup>b</sup>	H	CH <sub>2</sub>	H	CH <sub>2</sub>	174-176	...	C <sub>14</sub> H <sub>16</sub> ClNO <sup>c</sup>	67.32	6.46	5.61	67.48	6.36	5.55	++ <sup>d</sup>
84	H	CH <sub>2</sub>	H	(CH <sub>2</sub> ) <sub>2</sub>	99-100	...	C <sub>15</sub> H <sub>18</sub> ClNO <sup>c</sup>	68.30	6.88	5.31	68.53	6.66	5.32	++
85	H	(CH <sub>2</sub> ) <sub>2</sub>	H	CH <sub>2</sub>	117 (0.1)	1.5566	C <sub>15</sub> H <sub>17</sub> NO	79.26	7.54	6.16	79.26	7.50	6.08	-
86	H	CH <sub>2</sub>	H	CH(CH <sub>3</sub> )	124-126	...	C <sub>15</sub> H <sub>18</sub> ClNO <sup>c</sup>	68.30	6.88	5.31	68.34	6.62	5.41	-
87	H	CH <sub>2</sub>	H	(CH <sub>2</sub> ) <sub>3</sub>	134-135	...	C <sub>16</sub> H <sub>20</sub> ClNO <sup>c</sup>	69.18	7.26	5.04	69.52	7.26	5.33	+++ <sup>d</sup>
88	H	(CH <sub>2</sub> ) <sub>3</sub>	H	CH <sub>2</sub>	90-91	...	C <sub>16</sub> H <sub>20</sub> ClNO <sup>c</sup>	69.18	7.26	5.04	69.23	7.01	4.91	++
89	H	(CH <sub>2</sub> ) <sub>3</sub>	H	(CH <sub>2</sub> ) <sub>3</sub>	159 (0.1)	1.5445	C <sub>18</sub> H <sub>22</sub> NO	80.25	8.60	5.20	80.09	8.71	5.33	-
90	H	CH <sub>2</sub>	<i>o</i> -CH <sub>3</sub>	CH <sub>2</sub>	113 (0.1)	1.5618	C <sub>15</sub> H <sub>17</sub> NO	79.26	7.54	6.18	78.87	7.65	6.40	++ <sup>d</sup>
91	H	CH <sub>2</sub>	<i>m</i> -CH <sub>3</sub>	CH <sub>2</sub>	164-165	...	C <sub>15</sub> H <sub>18</sub> ClNO <sup>c</sup>	68.30	6.88	5.31	68.59	6.84	5.37	++
92	<i>o</i> -CH <sub>3</sub>	CH <sub>2</sub>	H	CH <sub>2</sub>	116 (0.1)	1.5630	C <sub>15</sub> H <sub>17</sub> NO	79.26	7.54	6.18	79.30	7.55	6.38	-
93	<i>m</i> -CH <sub>3</sub>	CH <sub>2</sub>	H	CH <sub>2</sub>	110 (0.1)	1.5593	C <sub>15</sub> H <sub>17</sub> NO	79.26	7.54	6.18	79.16	7.66	6.10	+++ <sup>d</sup>
94	<i>o</i> -CH <sub>3</sub>	CH <sub>2</sub>	<i>o</i> -CH <sub>3</sub>	CH <sub>2</sub>	161-163	...	C <sub>16</sub> H <sub>20</sub> ClNO <sup>c</sup>	69.18	7.26	5.04	68.98	7.82	5.16	++
95	<i>m</i> -CH <sub>3</sub>	CH <sub>2</sub>	<i>m</i> -CH <sub>3</sub>	CH <sub>2</sub>	120 (0.1)	1.5582	C <sub>16</sub> H <sub>19</sub> NO	79.63	7.94	5.80	79.68	7.72	5.84	++
96	<i>p</i> -CH <sub>3</sub>	CH <sub>2</sub>	<i>p</i> -CH <sub>3</sub>	CH <sub>2</sub>	58-60	...	C <sub>16</sub> H <sub>19</sub> NO	79.63	7.94	5.80	80.00	7.86	5.96	++ <sup>d</sup>
97	3,4-(CH <sub>3</sub> ) <sub>2</sub>	CH <sub>2</sub>	3,4-(CH <sub>3</sub> ) <sub>2</sub>	CH <sub>2</sub>	164-166	...	C <sub>18</sub> H <sub>24</sub> ClNO <sup>c</sup>	70.68	7.91	4.58	70.82	7.71	4.39	++
98	<i>o</i> -C <sub>2</sub> H <sub>5</sub>	CH <sub>2</sub>	<i>o</i> -C <sub>2</sub> H <sub>5</sub>	CH <sub>2</sub>	177-179	...	C <sub>18</sub> H <sub>24</sub> ClNO <sup>c</sup>	70.68	7.91	11.53 <sup>e</sup>	70.80	7.97	11.55 <sup>e</sup>	++
99	<i>p</i> - <i>i</i> -C <sub>3</sub> H <sub>7</sub>	CH <sub>2</sub>	<i>p</i> - <i>i</i> -C <sub>3</sub> H <sub>7</sub>	CH <sub>2</sub>	151-152	...	C <sub>20</sub> H <sub>28</sub> NO <sub>2</sub> <sup>f</sup>	60.73	7.39	3.54	60.64	7.40	3.56	-
100	<i>p</i> -CH <sub>3</sub>	(CH <sub>2</sub> ) <sub>3</sub>	<i>m</i> -CH <sub>3</sub>	CH <sub>2</sub>	142 (0.1)	1.5449	C <sub>18</sub> H <sub>22</sub> NO	80.25	8.60	5.20	80.12	8.56	5.20	-
101	<i>m</i> -CH <sub>3</sub>	CH <sub>2</sub>	H	(CH <sub>2</sub> ) <sub>3</sub>	99-100	...	C <sub>17</sub> H <sub>22</sub> ClNO <sup>c</sup>	69.97	7.60	4.80	70.27	7.66	4.53	-
102	<i>o</i> -OCH <sub>3</sub>	CH <sub>2</sub>	<i>o</i> -OCH <sub>3</sub>	CH <sub>2</sub>	155-157	...	C <sub>16</sub> H <sub>20</sub> ClNO <sub>2</sub> <sup>f</sup>	62.03	6.51	4.53	62.24	6.40	4.48	-
103 <sup>g</sup>	<i>m</i> -OCH <sub>3</sub>	CH <sub>2</sub>	<i>m</i> -OCH <sub>3</sub>	CH <sub>2</sub>	101-103	...	C <sub>16</sub> H <sub>20</sub> ClNO <sub>2</sub> <sup>f</sup>	62.03	6.51	4.53	62.28	5.87	4.47	-
104 <sup>h</sup>	<i>p</i> -OCH <sub>3</sub>	CH <sub>2</sub>	<i>p</i> -OCH <sub>3</sub>	CH <sub>2</sub>	56-57	...	C <sub>15</sub> H <sub>19</sub> NO <sub>3</sub>	70.30	7.01	5.13	70.06	6.90	5.01	++ <sup>d</sup>
105	2,6-(OCH <sub>3</sub> ) <sub>2</sub>	CH <sub>2</sub>	2,6-(OCH <sub>3</sub> ) <sub>2</sub>	CH <sub>2</sub>	166-168	...	C <sub>18</sub> H <sub>22</sub> NO <sub>2</sub>	64.85	6.94	4.20	64.48	6.71	4.50	-
106	<i>o</i> -OC <sub>2</sub> H <sub>5</sub>	CH <sub>2</sub>	<i>o</i> -OC <sub>2</sub> H <sub>5</sub>	CH <sub>2</sub>	115-117	...	C <sub>18</sub> H <sub>24</sub> ClNO <sub>2</sub> <sup>f</sup>	63.99	7.16	4.15	64.29	7.30	3.97	-
107 <sup>h</sup>	H	CH <sub>2</sub>	<i>o</i> -COOH	CH <sub>2</sub>	96	...	C <sub>15</sub> H <sub>16</sub> NO <sub>3</sub>	70.02	5.88	5.44	70.36	5.52	5.49	-
108	<i>m</i> -CF <sub>3</sub>	CH <sub>2</sub>	<i>m</i> -CF <sub>3</sub>	CH <sub>2</sub>	107-109	...	C <sub>16</sub> H <sub>14</sub> ClF <sub>3</sub> NO <sup>c,i</sup>	49.82	3.66	3.63	49.71	3.67	3.80	-
109	<i>o</i> -Cl	CH <sub>2</sub>	<i>o</i> -Cl	CH <sub>2</sub>	141-143	...	C <sub>14</sub> H <sub>14</sub> Cl <sub>2</sub> NO <sup>c,j</sup>	52.69	4.43	4.39	52.34	4.57	4.39	++
110 <sup>k</sup>	<i>p</i> -Cl	CH <sub>2</sub>	<i>p</i> -Cl	CH <sub>2</sub>	80-81	...	C <sub>14</sub> H <sub>13</sub> Cl <sub>2</sub> NO <sup>l</sup>	59.59	4.64	4.97	59.65	4.80	4.78	-

<sup>a</sup> At 0.25% diet level. See footnote a, Table I, for a description of the activity data. <sup>b</sup> See ref 6b. <sup>c</sup> Hydrochloride. <sup>d</sup> At 0.5% diet level. <sup>e</sup> Cl. <sup>f</sup> Hydrogen sulfate. <sup>g</sup> See ref 3a. <sup>h</sup> Obtained by alkaline hydrolysis of **77**. <sup>i</sup> *Anal.* Calcd: F, 29.55. Found: F, 29.45. <sup>j</sup> *Anal.* Calcd: Cl, 33.40. Found: Cl, 33.50. <sup>k</sup> See P. Mamalis, J. Green, D. J. Outred, and M. Rix, *J. Chem. Soc.*, 3915 (1962). <sup>l</sup> *Anal.* Calcd: Cl, 25.13. Found: Cl, 24.95.

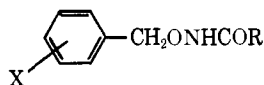
 TABLE VII  
 BENZYL ACYL- AND AROYLHYDROXAMATES

No.	X	R	Mp or bp (mm), °C	$n_{25}^D$	Formula	Calcd. %			Found. %			Activity <sup>a</sup>
						C	H	N	C	H	N	
36 <sup>b</sup>	H	Methyl	109 (0.2)	1.5381	C <sub>9</sub> H <sub>11</sub> NO <sub>2</sub>	65.43	6.71	8.48	65.24	7.01	8.37	+
37	H	Isopropyl	63-64	...	C <sub>11</sub> H <sub>15</sub> NO <sub>2</sub>	68.40	7.82	7.27	68.22	7.93	7.34	-
38	H	<i>n</i> -Propyl	56-58	...	C <sub>11</sub> H <sub>15</sub> NO <sub>2</sub>	68.40	7.82	7.27	68.08	7.98	7.35	+
39	H	<i>n</i> -Hexyl	142 (0.3)	1.5080	C <sub>14</sub> H <sub>17</sub> NO <sub>2</sub>	71.45	9.00	5.95	71.35	8.92	6.09	+
40	H	<i>n</i> -Heptyl	145 (0.3)	1.5049	C <sub>15</sub> H <sub>23</sub> NO <sub>2</sub>	72.25	9.29	5.62	72.45	9.21	5.91	+
41	H	<i>n</i> -Octyl	34-35	...	C <sub>16</sub> H <sub>23</sub> NO <sub>2</sub>	72.95	9.57	5.32	72.56	9.47	5.54	+
42	H	<i>n</i> -Tridecyl	72-73	...	C <sub>21</sub> H <sub>35</sub> NO <sub>2</sub>	75.60	10.58	4.20	75.59	10.62	4.19	+
43	H	<i>n</i> -Pentadecyl	81-83	...	C <sub>23</sub> H <sub>39</sub> NO <sub>2</sub>	76.40	10.87	3.87	76.67	10.85	4.08	+
44 <sup>b</sup>	H	Phenyl	102-103	...	C <sub>14</sub> H <sub>13</sub> NO <sub>2</sub>	73.99	5.77	6.17	74.19	5.85	6.08	-
45	<i>m</i> -CH <sub>3</sub>	<i>n</i> -Hexyl	158 (0.2)	1.5076	C <sub>15</sub> H <sub>23</sub> NO <sub>2</sub>	72.25	9.29	5.62	72.60	9.18	5.81	-
46	<i>m</i> -OCH <sub>3</sub>	Methyl	128 (0.1)	1.5418	C <sub>10</sub> H <sub>13</sub> NO <sub>3</sub>	61.52	6.71	7.20	61.69	6.81	7.13	-

<sup>a</sup> At 0.5% diet level. See footnote a, Table I, for a description of the activity data. <sup>b</sup> See ref 10. P. Mamalis, M. J. Rix, and A. A. Sarsfield, *J. Chem. Soc.*, 6278 (1965), have also reported the formation of this compound by the reaction of benzyl O-acetamidobenzoylhydroxamate and acetic anhydride.

(reaction 10) led to the desired unsymmetrical compounds of type C.

The serum cholesterol lowering activity of most of these compounds has been evaluated using male Charles River albino weanling rats according to the method described by Berger and his associates.<sup>4a</sup> The concentration of the drug in the diet was usually 0.25 or 0.50%. The screening data are included in Tables I-IX and are expressed in terms of reduction of serum cholesterol relative to control animals on the same diet without drug.

Of the various types of aralkoxyamine compounds evaluated, the most potent serum cholesterol lowering activity was exhibited by the aralkyl N-aralkylcarboxyhydroxamates (Table II). N-Aralkylaralkoxyamines (Table VI) were next in order of potency, followed by aralkyl N-aralkylacyl- and -aroylhydroxamates (Table VIII). The N-unsubstituted aralkoxyamines (Table V), their acyl- and aroylhydroxamate derivatives (Table VII), their carbalkoxy- and carbaryloxyhydroxamate derivatives (Table I), and the urea compounds derived from both the N-unsubstituted

TABLE VIII  
ARALKYL N-ARALKYLALCYL- AND -AROYLHYDROXAMATES

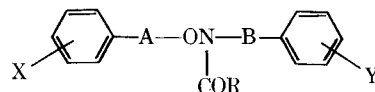

No.	X	A	Y	B	R	Mp or bp (mm), °C <sup>a</sup>	$n_D^{20}$	Formula	Caled, %			Found, %			Activity <sup>a</sup>
									C	H	N	C	H	N	
111	H	CH <sub>2</sub>	H	CH <sub>2</sub>	H	60-61	...	C <sub>15</sub> H <sub>15</sub> NO <sub>2</sub>	74.66	6.27	5.80	74.86	6.01	5.76	++
112 <sup>b</sup>	H	CH <sub>2</sub>	H	CH <sub>2</sub>	Methyl	57-58	...	C <sub>16</sub> H <sub>17</sub> NO <sub>2</sub>	75.27	6.71	5.49	75.29	7.25	5.61	++
113	H	CH <sub>2</sub>	H	CH <sub>2</sub>	Ethyl	146 (0.1)	1.5535	C <sub>17</sub> H <sub>19</sub> NO <sub>2</sub>	75.81	7.11	5.20	75.87	7.00	5.41	+
114	H	CH <sub>2</sub>	H	CH <sub>2</sub>	Isopropyl	136 (0.1)	1.5470	C <sub>18</sub> H <sub>21</sub> NO <sub>2</sub>	76.29	7.47	4.94	76.50	7.45	5.02	+++
115	H	CH <sub>2</sub>	H	CH <sub>2</sub>	<i>n</i> -Heptyl	167 (0.2)	1.5306	C <sub>22</sub> H <sub>29</sub> NO <sub>2</sub>	78.00	8.63	4.13	78.06	8.53	4.19	+++
116	H	CH <sub>2</sub>	H	CH <sub>2</sub>	Chloromethyl	<i>d</i>	1.5727	C <sub>16</sub> H <sub>16</sub> ClNO <sub>2</sub>	66.32	5.56	4.83	66.65	5.04	4.78	+
117 <sup>c</sup>	H	CH <sub>2</sub>	H	CH <sub>2</sub>	3-Carboxypropyl	83-85	...	C <sub>19</sub> H <sub>21</sub> NO <sub>4</sub>	69.71	6.46	4.28	69.90	6.18	4.27	-
118 <sup>f</sup>	H	CH <sub>2</sub>	H	CH <sub>2</sub>	Phenyl	65-67	...	C <sub>21</sub> H <sub>19</sub> NO <sub>2</sub>	79.47	6.04	4.41	79.22	6.23	4.59	+++
119	H	CH <sub>2</sub>	H	CH <sub>2</sub>	Benzyl	<i>d</i>	1.5866	C <sub>22</sub> H <sub>21</sub> NO <sub>2</sub>	79.73	6.39	4.23	80.25	6.59	4.18	-
120	H	CH <sub>2</sub>	H	CH <sub>2</sub>	Phenethyl	54-56	...	C <sub>23</sub> H <sub>23</sub> NO <sub>2</sub>	79.97	6.71	4.05	79.91	6.56	4.02	+
121	H	CH <sub>2</sub>	H	(CH <sub>2</sub> ) <sub>3</sub>	H	<i>d</i>	1.5559	C <sub>17</sub> H <sub>19</sub> NO <sub>2</sub>	75.81	7.11	5.20	76.13	7.24	5.25	++
122	H	CH <sub>2</sub>	H	(CH <sub>2</sub> ) <sub>3</sub>	Methyl	<i>d</i>	1.5503	C <sub>18</sub> H <sub>21</sub> NO <sub>2</sub>	76.29	7.47	4.94	76.06	7.10	5.38	++
123	H	CH <sub>2</sub>	H	(CH <sub>2</sub> ) <sub>3</sub>	Phenyl	<i>d</i>	1.5812	C <sub>23</sub> H <sub>23</sub> NO <sub>2</sub>	79.97	6.71	4.05	79.39	7.16	4.23	-
124	H	(CH <sub>2</sub> ) <sub>3</sub>	H	CH <sub>2</sub>	Methyl	145 (0.1)	1.5504	C <sub>18</sub> H <sub>21</sub> NO <sub>2</sub>	76.29	7.47	4.94	76.12	7.11	5.38	-
125	H	(CH <sub>2</sub> ) <sub>3</sub>	H	(CH <sub>2</sub> ) <sub>3</sub>	Phenyl	<i>d</i>	1.5715	C <sub>25</sub> H <sub>27</sub> NO <sub>2</sub>	80.39	7.29	3.75	80.84	7.47	3.68	-
126	<i>o</i> -CH <sub>3</sub>	CH <sub>2</sub>	H	CH <sub>2</sub>	Methyl	38-40	...	C <sub>17</sub> H <sub>19</sub> NO <sub>2</sub>	75.81	7.11	5.20	75.86	6.99	5.14	++
127	<i>m</i> -CH <sub>3</sub>	CH <sub>2</sub>	H	CH <sub>2</sub>	Methyl	141 (0.1)	1.5565	C <sub>17</sub> H <sub>19</sub> NO <sub>2</sub>	75.81	7.11	5.20	76.02	7.39	5.19	+
128	<i>m</i> -CH <sub>3</sub>	CH <sub>2</sub>	H	CH <sub>2</sub>	<i>n</i> -Hexyl	<i>d</i>	1.5308	C <sub>22</sub> H <sub>29</sub> NO <sub>2</sub>	77.84	8.63	4.13	77.90	8.62	4.19	++
129	H	CH <sub>2</sub>	<i>o</i> -CH <sub>3</sub>	CH <sub>2</sub>	Methyl	66-68	...	C <sub>17</sub> H <sub>19</sub> NO <sub>2</sub>	75.81	7.11	5.20	75.33	7.01	5.31	+
130	H	CH <sub>2</sub>	<i>m</i> -CH <sub>3</sub>	CH <sub>2</sub>	Methyl	141 (0.1)	1.5562	C <sub>17</sub> H <sub>19</sub> NO <sub>2</sub>	75.81	7.11	5.20	75.73	7.25	5.22	++
131	<i>o</i> -CH <sub>3</sub>	CH <sub>2</sub>	<i>o</i> -CH <sub>3</sub>	CH <sub>2</sub>	Methyl	79-81	...	C <sub>18</sub> H <sub>21</sub> NO <sub>2</sub>	76.29	7.47	4.94	76.26	7.42	4.97	--
132	<i>o</i> -CH <sub>3</sub>	CH <sub>2</sub>	<i>o</i> -CH <sub>3</sub>	CH <sub>2</sub>	Isopropyl	147 (0.1)	1.5471	C <sub>20</sub> H <sub>25</sub> NO <sub>2</sub>	77.13	8.09	4.50	76.95	8.15	4.28	++
133	<i>o</i> -CH <sub>3</sub>	CH <sub>2</sub>	<i>o</i> -CH <sub>3</sub>	CH <sub>2</sub>	Phenyl	93-95	...	C <sub>23</sub> H <sub>23</sub> NO <sub>2</sub>	79.97	6.71	4.05	79.44	6.60	4.28	++
134	<i>m</i> -CH <sub>3</sub>	CH <sub>2</sub>	<i>m</i> -CH <sub>3</sub>	CH <sub>2</sub>	Methyl	<i>d</i>	1.5534	C <sub>18</sub> H <sub>21</sub> NO <sub>2</sub>	76.29	7.47	4.94	76.12	7.66	5.19	++
135	3,4-(CH <sub>3</sub> ) <sub>2</sub>	CH <sub>2</sub>	3,4-(CH <sub>3</sub> ) <sub>2</sub>	CH <sub>2</sub>	Methyl	<i>d</i>	1.5554	C <sub>20</sub> H <sub>25</sub> NO <sub>2</sub>	77.13	8.09	4.50	76.81	7.83	4.97	+++
136	<i>m</i> -CH <sub>3</sub>	CH <sub>2</sub>	H	(CH <sub>2</sub> ) <sub>3</sub>	Methyl	<i>d</i>	...	C <sub>19</sub> H <sub>23</sub> NO <sub>2</sub>	76.72	7.79	4.71	76.57	7.61	4.97	+++
137	<i>m</i> -CH <sub>3</sub>	CH <sub>2</sub>	H	(CH <sub>2</sub> ) <sub>3</sub>	Phenyl	<i>d</i>	1.5768	C <sub>24</sub> H <sub>25</sub> NO <sub>2</sub>	80.19	7.01	3.90	80.69	7.35	4.13	++
138	H	(CH <sub>2</sub> ) <sub>3</sub>	<i>m</i> -CH <sub>3</sub>	CH <sub>2</sub>	Methyl	140 (0.1)	1.5474	C <sub>19</sub> H <sub>23</sub> NO <sub>2</sub>	76.73	7.80	4.71	76.59	7.89	4.75	-
139	<i>p</i> -OCH <sub>3</sub>	CH <sub>2</sub>	<i>p</i> -OCH <sub>3</sub>	CH <sub>2</sub>	Methyl	36-37	...	C <sub>18</sub> H <sub>21</sub> NO <sub>4</sub>	68.55	6.71	4.44	68.05	6.32	4.84	-
140	<i>p</i> -OCH <sub>3</sub>	CH <sub>2</sub>	<i>p</i> -OCH <sub>3</sub>	CH <sub>2</sub>	Isopropyl	<i>d</i>	1.5499	C <sub>20</sub> H <sub>25</sub> NO <sub>4</sub>	69.94	7.34	4.08	70.11	7.31	4.25	++
141	<i>p</i> -OCH <sub>3</sub>	CH <sub>2</sub>	<i>p</i> -OCH <sub>3</sub>	CH <sub>2</sub>	Phenyl	102-103	...	C <sub>23</sub> H <sub>23</sub> NO <sub>4</sub>	73.19	6.14	3.71	72.98	6.32	3.79	-
142	<i>m</i> -CF <sub>3</sub>	CH <sub>2</sub>	<i>m</i> -CF <sub>3</sub>	CH <sub>2</sub>	Methyl	<i>d</i>	1.4845	C <sub>18</sub> H <sub>15</sub> F <sub>6</sub> NO <sub>2</sub>	55.25	3.86	3.58	55.19	3.68	3.65	++
143	<i>p</i> -Cl	CH <sub>2</sub>	<i>p</i> -Cl	CH <sub>2</sub>	Methyl	41-44	...	C <sub>16</sub> H <sub>15</sub> Cl <sub>2</sub> NO <sub>2</sub>	59.28	4.66	21.87 <sup>g</sup>	59.14	4.61	22.19 <sup>g</sup>	++
144	<i>p</i> -Cl	CH <sub>2</sub>	<i>p</i> -Cl	CH <sub>2</sub>	Isopropyl	57-59	...	C <sub>18</sub> H <sub>15</sub> Cl <sub>2</sub> NO <sub>2</sub>	61.35	5.44	20.13 <sup>g</sup>	61.13	5.12	19.97 <sup>g</sup>	--
145	<i>p</i> -Cl	CH <sub>2</sub>	<i>p</i> -Cl	CH <sub>2</sub>	Phenyl	79-82	...	C <sub>20</sub> H <sub>17</sub> Cl <sub>2</sub> NO <sub>2</sub>	65.30	4.44	18.35 <sup>g</sup>	65.07	4.56	18.51 <sup>g</sup>	+
146	H	CH <sub>2</sub>	<i>o</i> -CO <sub>2</sub> H	CH <sub>2</sub>	Methyl	120-122	...	C <sub>17</sub> H <sub>17</sub> NO <sub>4</sub>	68.21	5.73	4.57	68.39	5.57	4.57	++

<sup>a</sup> At 0.25% diet level. See footnote a, Table I, for a description of the activity data. <sup>b</sup> See ref 10. <sup>c</sup> At 0.5% diet level. <sup>d</sup> These compounds were purified by short-path distillation at 100-120° bath temperature (0.001 mm) since decomposition occurred in attempts to use conventional equipment. <sup>e</sup> Obtained from glutaric anhydride and N-benzylbenzylamine. <sup>f</sup> B. Behrend and K. Leuchs, *Ann. Chem.*, **257**, 203 (1890). <sup>g</sup> Cl.

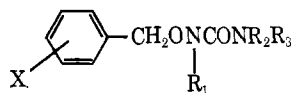
TABLE IX  
 ARALKOXYUREA COMPOUNDS

No.	X	R <sub>1</sub>	Method	R <sub>2</sub>	R <sub>3</sub>	Mp, °C	Formula	Calcd, %			Found, %			Activity <sup>a</sup>
								C	H	N	C	H	N	
181 <sup>b</sup>	H	H		H	H	139-141	C <sub>8</sub> H <sub>10</sub> N <sub>2</sub> O <sub>2</sub>	57.81	6.07	16.88	57.56	6.08	16.64	+
182	H	H	12a	H	C <sub>2</sub> H <sub>5</sub>	51-52	C <sub>10</sub> H <sub>14</sub> N <sub>2</sub> O <sub>2</sub>	61.83	7.27	14.42	61.74	7.04	14.26	-
183	H	H	11	H	COCH <sub>3</sub>	139-140	C <sub>10</sub> H <sub>12</sub> N <sub>2</sub> O <sub>3</sub>	57.68	5.81	13.46	57.89	5.68	13.20	+
184	<i>p</i> -Cl	H	11	H	COCH <sub>3</sub>	172-174	C <sub>10</sub> H <sub>11</sub> ClN <sub>2</sub> O <sub>3</sub> <sup>c</sup>	49.49	4.57	11.54	49.47	4.36	11.55	-
185	3,4-Cl <sub>2</sub>	H	11	H	COCH <sub>3</sub>	162-164	C <sub>10</sub> H <sub>10</sub> Cl <sub>2</sub> N <sub>2</sub> O <sub>3</sub> <sup>d</sup>	43.34	3.64	10.11	43.48	3.77	9.86	-
186 <sup>e</sup>	H	Benzyl		H	H	98-100	C <sub>15</sub> H <sub>16</sub> N <sub>2</sub> O <sub>2</sub>	70.29	6.29	10.93	69.60	6.27	11.05	+ <sup>f</sup>
187	H	Benzyl	12a	H	C <sub>2</sub> H <sub>5</sub>	60-61	C <sub>17</sub> H <sub>20</sub> N <sub>2</sub> O <sub>2</sub>	71.80	7.09	9.85	71.60	7.17	9.83	- <sup>g</sup>
188	H	Benzyl	11	H	COCH <sub>3</sub>	61-62	C <sub>17</sub> H <sub>18</sub> N <sub>2</sub> O <sub>3</sub>	68.44	6.08	9.39	68.18	6.03	9.37	+ <sup>g</sup>
189	H	Benzyl	12b	Benzyl	Benzoyloxy	40-41	C <sub>23</sub> H <sub>28</sub> N <sub>2</sub> O <sub>3</sub>	76.96	6.24	6.19	77.05	6.18	6.14	+ <sup>g</sup>
190	<i>p</i> -CH <sub>3</sub> <sup>h</sup>	H	11	H	COCH <sub>3</sub>	144-146	C <sub>15</sub> H <sub>20</sub> N <sub>2</sub> O <sub>3</sub>	69.21	6.45	8.97	69.23	6.28	8.79	+
191	H <sup>h</sup>	$\gamma$ -Phenylpropyl	11	H	COCH <sub>3</sub>	44-45	C <sub>21</sub> H <sub>26</sub> N <sub>2</sub> O <sub>3</sub>	71.16	7.39	7.91	71.43	7.45	7.71	+
192	H <sup>i</sup>	H	11	H	COCH <sub>3</sub>	97-98	C <sub>13</sub> H <sub>18</sub> N <sub>2</sub> O <sub>4</sub>	58.63	6.82	10.52	58.52	6.76	10.39	+
193	H <sup>i</sup>	$\gamma$ -Phenoxypropyl	11	H	COCH <sub>3</sub>	65-67	C <sub>21</sub> H <sub>26</sub> N <sub>2</sub> O <sub>5</sub>	65.27	6.78	7.25	64.96	6.69	7.20	-

<sup>a</sup> At 0.25% diet level. See footnote a, Table I, for a description of the activity data. <sup>b</sup> R. Behrend and K. Leuchs, *Ann. Chem.*, **257**, 203 (1890). <sup>c</sup> *Anal.* Calcd: Cl, 14.61. Found: Cl, 14.72. <sup>d</sup> *Anal.* Calcd: Cl, 25.59. Found: Cl, 25.70. <sup>e</sup> See ref 6b. <sup>f</sup> At 1.0% diet level. <sup>g</sup> At 0.5% diet level. <sup>h</sup>  $\gamma$ -Phenylpropoxy derivative. <sup>i</sup>  $\gamma$ -Phenoxypropoxy derivative.

aralkoxyamines and N-aralkylaralkoxyamines (Table IX) all were significantly less effective.

Replacement of the aralkoxy group with aryloxyalkoxy in these compounds (Table IV) resulted in a general enhancement of activity while substitution of the N-aralkyl group with aryloxyalkyl (Table III) usually gave compounds of superior serum cholesterol lowering activity.

### Experimental Section<sup>13</sup>

***m*-Trifluoromethylbenzyl Carbethoxyhydroxamate (18, Reaction 1).**—A sodium ethoxide solution was prepared from 6.9 g of sodium and 500 ml of anhydrous ethanol. N-Hydroxyurethan (31.5 g, 0.3 mole) was added to this solution at room temperature. *m*-Trifluoromethylbenzyl bromide (71.7 g, 0.3 mole) was then added at such a rate that the temperature did not exceed 30°. The mixture was stirred for 3 hr at room temperature and most of the ethanol was removed by distillation. The residue was diluted with water and extracted with ether. The dried ether solution was evaporated leaving a residue which solidified on standing. Recrystallization from CCl<sub>4</sub>-hexane furnished the desired carbethoxyhydroxamate (38.2 g, 48%).

***o*-Methylbenzyl N-(*o*-Methylbenzyl)carbethoxyhydroxamate (65, Reaction 2).**—A solution of N-hydroxyurethan (28.4 g, 0.27 mole) in 150 ml of ethanol was cooled to 0°. Ethanolic KOH (250 ml, 2.16 *N*) was added at that temperature and  $\alpha$ -bromo-*o*-xylene (100 g, 0.54 mole) then was added at such a rate that the temperature did not exceed 30°. The mixture was stirred for 2 hr at room temperature and most of the ethanol was removed by distillation. The cooled residue was diluted with ether and the inorganic salts were separated by filtration. The ether solution was washed (dilute NaOH, H<sub>2</sub>O) until neutral. Distillation of the dried solution afforded the desired carbethoxyhydroxamate (59.4 g, 70%), *n*<sub>D</sub><sup>20</sup> 1.5401.

**$\gamma$ -Phenylpropyl N-Benzylcarbethoxyhydroxamate (55, Reaction 9).**— $\gamma$ -Phenylpropyl carbethoxyhydroxamate (9, 80.3 g, 0.36 mole) was added at room temperature to a solution of sodium ethoxide (from 8.3 g of Na and 350 ml of ethanol). The mixture was stirred and benzyl bromide (61.5 g, 0.36 mole) was added dropwise at ca. 30°. Stirring was continued for 3 hr at room temperature, then the bulk of the ethanol was removed by distillation. The residue was diluted with water and the oil which separated was extracted with ether. This extract was washed (dilute NaOH, dilute HCl, H<sub>2</sub>O) until neutral. Distillation of the

dried solution yielded 103 g (77%) of the desired carbethoxyhydroxamate.

**N-Benzylcarbethoxyhydroxamic acid** was obtained by the reaction of ethyl chloroformate and N-benzylhydroxylamine, following the procedure described by Zinner<sup>12</sup> for the preparation of ethyl carbethoxyhydroxamic acid. It was obtained as a colorless liquid, bp 114-115° (0.05 mm), *n*<sub>D</sub><sup>20</sup> 1.5236.

*Anal.* Calcd for C<sub>10</sub>H<sub>13</sub>NO<sub>3</sub>: C, 61.51; H, 6.66; N, 7.17. Found: C, 61.67; H, 6.42; N, 7.35.

***m*-Methylbenzyl N-Benzylcarbethoxyhydroxamate (62, Reaction 10).**—N-Benzylcarbethoxyhydroxamic acid (97.6 g, 0.5 mole) was added to a sodium ethoxide solution (from 11.5 g of Na and 500 ml of ethanol).  $\alpha$ -Bromo-*m*-xylene (92.5 g, 0.5 mole) was added with stirring and intermittent cooling to keep the temperature below 30°. The mixture was stirred at ca. 60° until the FeCl<sub>3</sub> test was negative (about 4 hr). Most of the ethanol was then removed and the residue was diluted with water. The organic layer was extracted into ether and the ether solution was washed (dilute NaOH, dilute HCl, H<sub>2</sub>O) until neutral. Purification was effected by distillation, yield 118 g (79%).

***m*-Trifluoromethylbenzylcarbethoxyhydroxamate Hydrochloride (31, Reaction 3).**—A solution of 18 (19.7 g, 0.075 mole) and NaOH (6.0 g, 0.15 mole) in 300 ml of 50% ethanol was heated under reflux for 1 hr. The ethanol was then removed by distillation and the cooled residue was extracted with ether. The extract was dried (Na<sub>2</sub>SO<sub>4</sub>) and 15 ml of 5 *N* ethanolic HCl was added carefully. The dense precipitate which formed was separated and recrystallized from ethanol-ether to give 14.4 g (85%) of the amine hydrochloride.

**N-(*p*-Chlorobenzyl)-*p*-chlorobenzylcarbethoxyhydroxamate (80, 16.3 g, 0.045 mole) and of NaOH (5.5 g, 0.135 mole) in 200 ml of 50% ethanol was refluxed for 1 hr. The ethanol was removed by distillation. The residue separated a solid upon cooling that was dissolved in ether. This solution was washed with water and dried (Na<sub>2</sub>SO<sub>4</sub>). Evaporation of the ether yielded a solid which was purified by crystallization from 25 ml of methanol to give 7.5 g (58%) of the desired hydroxylamine.**

***m*-Methoxybenzylcarbethoxyhydroxamate (29, Reactions 1 and 3).**—A solution containing N-hydroxyurethan (17.7 g, 0.17 mole) and *m*-methoxybenzyl chloride (26.7 g, 0.17 mole) in 125 ml of ethanol was heated to reflux. Alcoholic KOH (50 ml, 3.4 *N*) was then added dropwise over a period of 2 hr. Heating was continued for another 2 hr after which 132 ml of 20% aqueous KOH was added. The mixture was refluxed for 3 additional hr and the bulk of the ethanol was removed by distillation. The residue was diluted with water and extracted with ether. This solution was washed with an excess of dilute HCl and the acid extract was made alkaline with NaOH. The oil which separated was extracted with ether. Distillation of the dried extract yielded 12.2 g (47%) of *m*-methoxybenzylcarbethoxyhydroxamate.

**Benzyl Carbo-*n*-hexoxyhydroxamate (5, Reaction 5).**—A solution of benzylcarbethoxyhydroxamate (49.2 g, 0.4 mole) in 250 ml of ether

(13) The compound numbers refer to the numbers in Tables I-IX. The reaction numbers are those used in Chart I and correspond to the method numbers included in the tables. Melting points are corrected and were obtained using a Thomas-Hoover apparatus. Boiling points represent average values. Microanalyses are by Galbraith Laboratories, Knoxville, Tenn.



was added dropwise with stirring to *n*-hexyl chloroformate (33 g, 0.2 mole) in 1 l. of ether. The temperature was kept at 20° by intermittent cooling. A dense precipitate of benzyloxyamine hydrochloride appeared immediately and was removed by filtration. The filtrate was evaporated to a thick oil which solidified on standing. Recrystallization from methanol-water (4:1) afforded the desired hydroxamate ester (33 g, 66%).

***o*-Methylbenzyl N-(*o*-Methylbenzyl)carbomethoxyhydroxamate (64, Reaction 6).**—Methyl chloroformate (14.2 g, 0.15 mole) was added dropwise with good stirring to a solution of *N*-(*o*-methylbenzyl)-*o*-methylbenzyloxyamine (94, 36.2 g, 0.15 mole) and 23 g of pyridine (100% excess) in 300 ml of ether. The temperature was kept below 30° by intermittent cooling. The turbid mixture was stirred for 3 hr. Water was added, the layers were separated, and the ether solution was washed repeatedly with dilute HCl. Evaporation of the dried ether left an oily residue. Attempted distillation of this oil in conventional equipment led to signs of decomposition at a head temperature of 140° (0.2 mm). The material was purified by short-path distillation at 0.001 mm and 100–120° bath temperature. The desired carbomethoxyhydroxamate was obtained as a colorless oil (37.7 g, 84%).

**Benzyl Octanohydroxamate (40, Reaction 7).**—Octanoyl chloride (19.6 g, 0.12 mole) was added dropwise with stirring to a solution of benzyloxyamine (29.5 g, 0.24 mole) in 250 ml of ether. The mixture was stirred at room temperature for 2 hr and the precipitate of benzyloxyamine hydrochloride was removed by filtration. The filtrate was washed with water and dried (Na<sub>2</sub>SO<sub>4</sub>). Solvent removal and distillation yielded 17.9 g (60%) of 40.

**Benzyl N-Benzylformhydroxamate (111, Reaction 8).**—Formamide (15 ml) was heated on a steam bath and *N*-benzylbenzyloxyamine hydrochloride (83, 15 g) was added with stirring in five portions at intervals such that the previous portion was practically dissolved before the next addition was made. The mixture was heated for 1 hr and then cooled to room temperature. The product separated as a lump. Water was added and the mixture was extracted with ether. Evaporation of the ether solution produced a solid which was recrystallized from 30 ml of methanol to give 9.0 g (60%) of purified product.

**Benzyl N-Benzylacetohydroxamate (112, Reaction 8).**—Acetyl chloride (38.5 g, 0.5 mole) was added slowly with good stirring to *N*-benzylbenzyloxyamine (213 g, 1.0 mole) in 1.5 l. of ether. A precipitate separated immediately. The mixture was heated under reflux for 1 hr and the *N*-benzylbenzyloxyamine hydrochloride (119.7 g, 96%) was separated. The filtrate was evaporated and the solid residue which remained was dissolved in 200 ml of ether. Careful addition of hexane (1.4 l.) precipitated the desired acetohydroxamate (107 g, 84%). This product was identical in every respect (melting point, mixture melting

point, infrared spectrum) with that obtained following the procedure of Cooley, *et al.*<sup>10</sup> for the benzylation of acetyldroxyamic acid.

**N-Benzyl-N-benzyloxy-N'-ethylurea (187, Reaction 12a).**—A solution of ethyl isocyanate (10.7 g, 0.15 mole) in 30 ml of anhydrous ether was added dropwise to a solution of *N*-benzylbenzyloxyamine (32 g, 0.15 mole) in 150 ml of anhydrous ether. The reaction mixture was refluxed for 2 hr and then distilled to remove the ether. The residue which solidified on cooling was recrystallized from petroleum ether to give 27 g of product. The melting point and analytical data for this compound and for *N*-benzyloxy-*N'*-ethylurea (182), prepared by the same method, are summarized in Table IX.

**N-(*p*-Chlorobenzyloxy)-N'-acetylurea (184, Reaction 11).**—To a slurry of silver cyanate (12.5 g, 0.083 mole) in 120 ml of anhydrous ether was added acetyl chloride (6.55 g, 0.083 mole) at a rate sufficient to maintain gentle reflux. The mixture was stirred at room temperature for 2 hr and then filtered into a flask containing a solution of *p*-chlorobenzyloxyamine (13.1 g, 0.083 mole) in 50 ml of anhydrous ether. The mixture was stirred at room temperature for 1 hr, cooled, and filtered. The solid was recrystallized from 265 ml of methanol, yielding 9.2 g of product. The melting point and analytical data for this compound and for the other ureides prepared by this procedure are included in Table IX.

**N,N'-Dibenzyl-N,N'-dibenzyloxyurea (189, Reaction 12b).**—*N*-Benzylbenzyloxyamine (91.8 g, 0.43 mole) was added dropwise with cooling and stirring to a solution of phosgene (10.7 g, 0.108 mole) in 1 l. of toluene. The mixture was filtered and the solid was washed with 400 ml of toluene and 400 ml of ether. The filtrates were combined and distilled to a vapor temperature of 90° (0.05 mm). The remaining oil solidified after standing at room temperature for 1 month. It was further purified by crystallizing from 110 ml of ethanol to give 29 g of product.

**4-Aminobenzyl Carbethoxyhydroxamate Hydrochloride (24).**—A solution of 4-nitrobenzyl carbethoxyhydroxamate (23, 24 g, 0.1 mole) in 130 ml of ethanol was hydrogenated over Pt black in a Parr shaker. The hydrogen uptake ceased after 0.1 mole of H<sub>2</sub> had been absorbed. The filtered solution was diluted with ether and excess ethanolic HCl was added. A precipitate formed and was separated. Recrystallization of the precipitate from ethanol furnished the desired ester in the form of its hydrochloride salt (18.2 g, 74%).

**Acknowledgment.**—The authors are indebted to Dr. S. Margolin and to Dr. J. F. Douglas for making the results of the biological evaluations available. Assistance by Dr. L. S. Powell, Messrs. T. Cebalo, M. Meyer, and F. J. Stiefel in the preparation of a number of the compounds described in this paper is also acknowledged.