

truncation provides a new route for the synthesis of AII antagonists. The effect of [Sar¹]AII-(1-7)carboxamide on other angiotensin-mediated responses, e.g. secretion of catecholamines and aldosterone, renin release, and central nervous system effects, have yet to be determined. Further structure-activity relationship studies, including the effect of additional deletions at the C-terminus, are now under investigation.

Acknowledgment. We acknowledge R. I. Hecht, M. G. Jennings, and J. F. Zobel for sequencing and amino acid analysis and P. Toren and E. W. Kolodziej for mass

spectroscopy. We also wish to thank E. H. Blaine and R. E. Manning for support during this work.

* To whom all correspondence should be addressed.

**P. R. Bovy,* A. J. Trapani
E. G. McMahon, M. Palomo**

*Cardiovascular Research
G.D. Searle & Co.
Monsanto Life Sciences Research Center
700 Chesterfield Village Parkway
Chesterfield, Missouri 63198*

Received August 17, 1988

Articles

Synthesis of Gastrin Antagonists, Analogues of the C-Terminal Tetrapeptide of Gastrin, by Introduction of a β -Homo Residue

M. Rodriguez, P. Fulcrand, J. Laur, A. Aumelas, J. P. Bali,[†] and J. Martinez*

Centre CNRS-INSERM de Pharmacologie-Endocrinologie, Rue de la Cardonille, 34094 Montpellier, France, and ER CNRS 228, Faculté de Pharmacie, Montpellier, France. Received June 6, 1988

A series of analogues of Boc-Trp-Leu-Asp-Phe-NH₂, a potent gastrin agonist, were synthesized by introducing a β -homo residue in the sequence. These compounds were tested in vivo on acid secretion, in the anesthetized rat, and for their ability to inhibit binding of labeled gastrin to its receptors on gastric mucosal cells. These analogues behaved as gastrin antagonists. The most potent compounds in this series were Boc-Trp-Leu- β -homo-Asp-NHCH₂C₆H₅ (10) (IC₅₀ = 1 μ M, ED₅₀ = 0.2 mg/kg), Boc-Trp-Leu- β -homo-Asp-NHCH₂CH₂C₆H₅ (11) (IC₅₀ = 0.75 μ M, ED₅₀ = 0.5 mg/kg), Boc-Trp-Leu- β -homo-Asp-Phe-NH₂ (12) (IC₅₀ = 1.5 μ M, ED₅₀ = 0.1 mg/kg), and Boc-Trp-Leu- β -homo-Asp-D-Phe-NH₂ (13) (IC₅₀ = 2 μ M, ED₅₀ = 0.1 mg/kg). We could demonstrate the importance of the region of the peptide bond between leucine and aspartic acid and of the structure of the C-terminal dipeptide Asp-Phe-NH₂, for exhibiting biological activity on acid secretion.

Gastrin is a peptide hormone which was isolated from hog antral mucosa by Gregory and Tracy.¹ It exists in an unsulfated (gastrin I) and in a sulfated form (gastrin II). Among the numerous biological actions of gastrin, we have been particularly interested in its property of stimulating gastric acid secretion.² It was demonstrated early on that the C-terminal tetrapeptide of gastrin was able to display the whole range of the biological activities of gastrin.³ Extensive structure-activity relationships⁴ have shown that replacement of tryptophan and aspartic acid lead to weakly active or inactive compounds, whereas methionine can be substituted by a leucine or norleucine without significant loss of activity. We have recently demonstrated the importance of the peptide bonds of the C-terminal tetrapeptide of gastrin for biological activity, particularly the bond between methionine and aspartic acid. The pseudopeptide Boc-Trp-Leu- ψ (CH₂NH)-Asp-Phe-NH₂, in which the peptide bond between leucine and aspartic acid had been replaced by a CH₂NH bond, was found to bind to the gastrin receptor with the same apparent affinity as the C-terminal tetrapeptide analogue of gastrin, Boc-Trp-Leu-Asp-Phe-NH₂, but was unable to stimulate gastric acid secretion. In fact, this compound was an inhibitor of gastrin-induced acid secretion, with an ED₅₀ value of 0.3 mg/kg.⁵ To the contrary, the pseudopeptide analogue bearing a "reduced bond" between tryptophan and leucine, i.e. Boc-Trp- ψ (CH₂NH)-Leu-Asp-Phe-NH₂, behaved as a full agonist of gastrin, with the same potency and efficacy as Boc-Trp-Leu-Asp-Phe-NH₂. We thus postulated that the bond between methionine (or leucine) and aspartic acid

should be a peptide bond, in order to exhibit agonist activity on gastric acid secretion. Moreover, we observed an enzymatic cleavage between Met (or Leu) and Asp when gastrin analogues were incubated with a gastric mucosal cell membrane preparation⁶ and even with gastric mucosal cells.⁷ Whether or not this enzymatic cleavage is related to biological activity remains to be demonstrated. In previous works, we also investigated several modifications of this C-terminal dipeptide, i.e. substitution of the phenylalanine amide by a 2-phenylethylamine⁸ or a 2-phenylethanol,⁹ or retro-inverso modifications,¹⁰ which all led to potent gastrin antagonists.

We thus speculated that modifications involving either the bond between methionine (or leucine) and aspartic acid (that would make it stable to enzymatic degradation) or specific modifications affecting the dipeptide Asp-Phe-NH₂

- (1) Gregory, R. A.; Tracy, H. *J. Gut* 1964, 5, 103.
- (2) Clark, J. L.; Steiner, D. F. *Proc. Natl. Acad. Sci. U.S.A.* 1976, 73, 1964.
- (3) Tracy, H. J.; Gregory, R. A. *Nature (London)* 1964, 204, 935.
- (4) Morley, J. S. *Proc. R. Soc. London, Ser. B* 1968, 170, 97.
- (5) Martinez, J.; Bali, J. P.; Rodriguez, M.; Castro, B.; Magous, R.; Laur, J.; Lignon, M. F. *J. Med. Chem.* 1985, 28, 1874.
- (6) Dubreuil, P.; Lignon, M. F.; Magous, R.; Rodriguez, M.; Bali, J. P.; Martinez, J. *Drug Design Delivery* 1987, 2, 49.
- (7) Dubreuil, P.; Galas, M. C.; Lignon, M. F.; Rodriguez, M.; Bali, J. P.; Martinez, J. *2ème Forum Peptides*, May 2-6, 1988, Nancy, France (Abstract).
- (8) Martinez, J.; Rodriguez, M.; Bali, J. P.; Laur, J. *Int. J. Peptide Protein Res.* 1986, 28, 529.
- (9) Martinez, J.; Rodriguez, M.; Bali, J. P.; Laur, J. *J. Med. Chem.* 1986, 29, 2201.
- (10) Rodriguez, M.; Dubreuil, P.; Bali, J. P.; Martinez, J. *J. Med. Chem.* 1987, 30, 758.

[†] Faculté de Pharmacie.

Scheme I

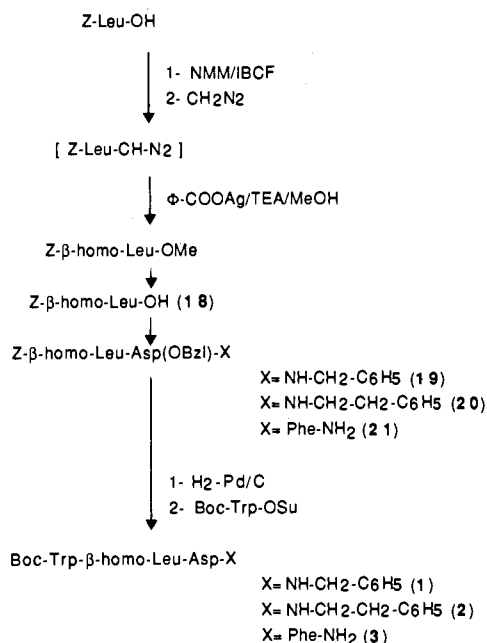

Scheme II

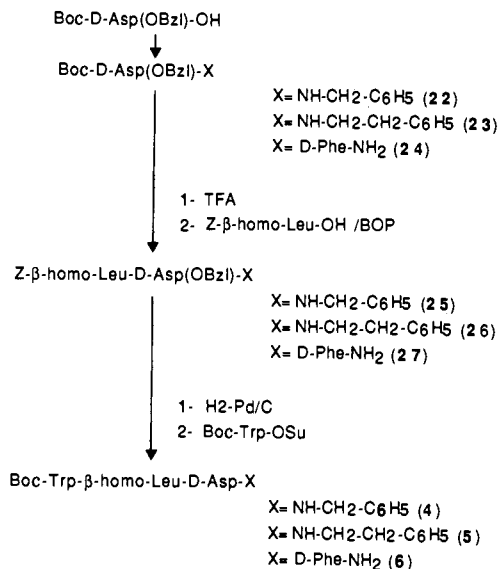

would lead to gastrin antagonists. In our continuous effort to design new inhibitors of gastrin-induced acid secretion, we describe in the present paper syntheses of a series of tetragastrin analogues in which the residues Leu, Asp, and Phe have been successively replaced by their β -homo analogues (insertion of a methylene group between the α -CH and the carboxylic group) and/or their optical isomers, and we examined their activity on acid secretion in the rat (Ghosh and Schild model¹¹), as well as their ability to inhibit binding of labeled gastrin to rabbit gastric mucosal cells.

Chemistry

Compounds 1-17 were synthesized in solution according to the usual methods of peptide synthesis (Schemes I-VI). The β -homo analogues of amino acids were obtained by the Arndt-Eistert synthesis as described by Wakamiya et al.¹² Proton NMR data and assignments for compounds

Scheme III

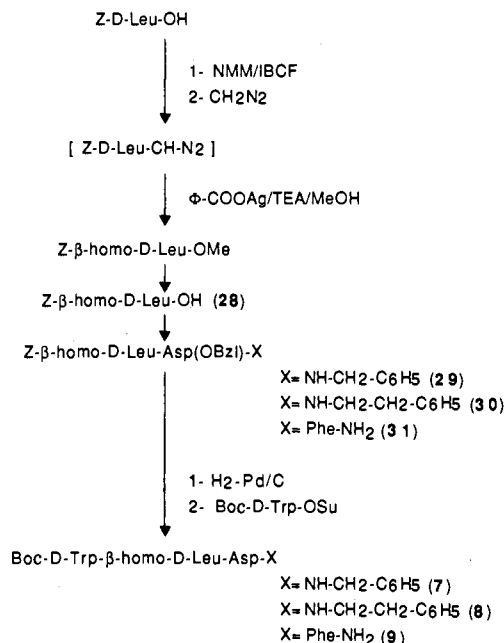

Scheme IV

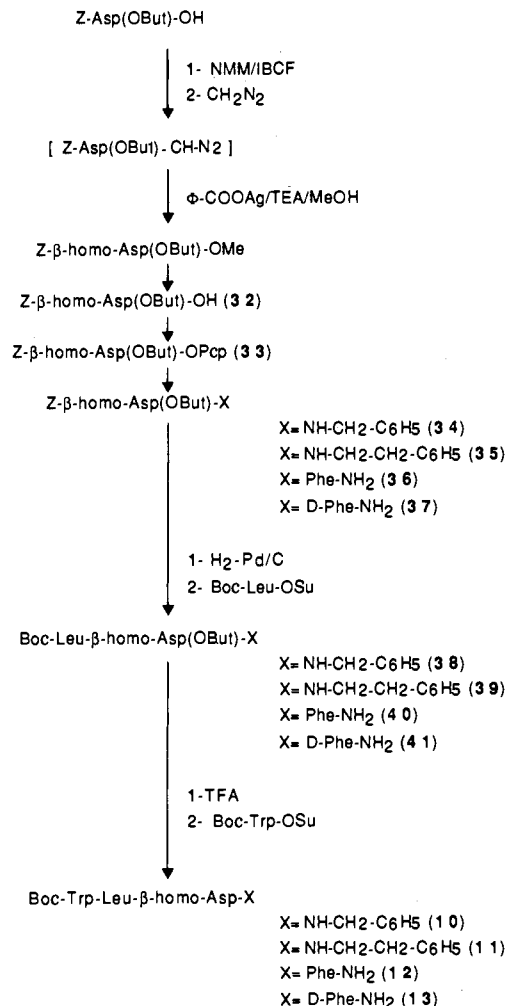

1-17 are provided in Tables III-XIII in the supplementary material.

As the introduction of a methylene group in the main chain of the peptides might alter the spatial orientation of the side chains, we decided to invert the configuration

(11) Ghosh, M. N.; Schild, H. O. *J. Physiol. Chem.* 1955, 128, 35.
(12) Wakamiya, T.; Uratani, H.; Teshima, T.; Shiba, T. *Bull. Chem. Soc. Jpn.* 1975, 48, 2401.

Scheme V

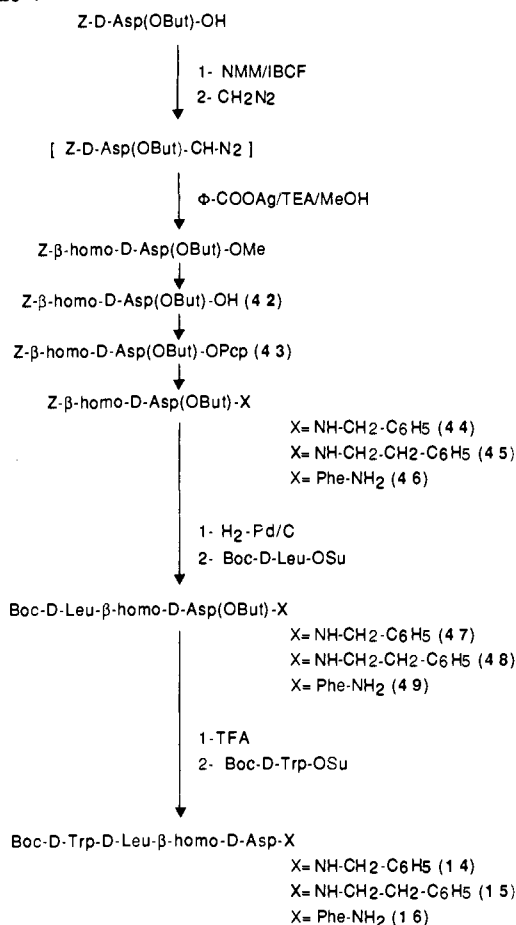

Scheme VI

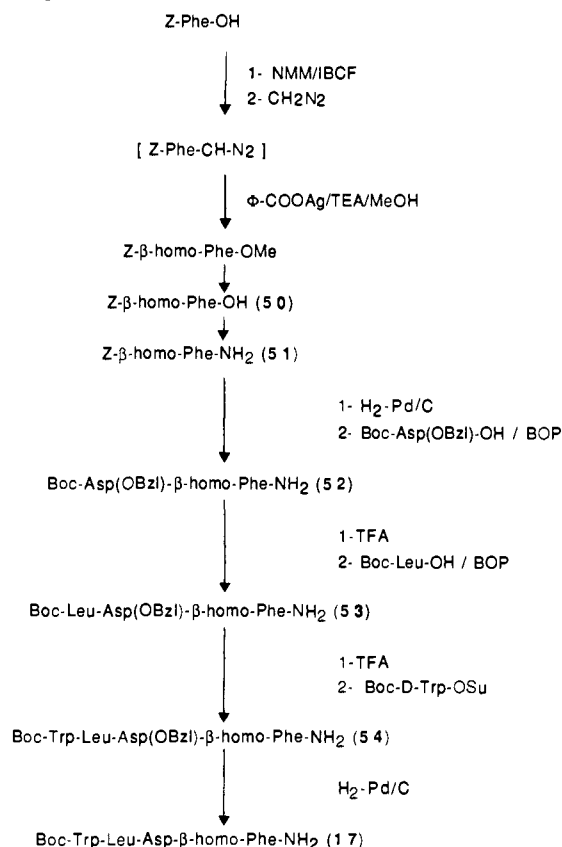

of the residues preceding or following the β-homo-modified amino acid, as described in Figure 1, in order to mimic the

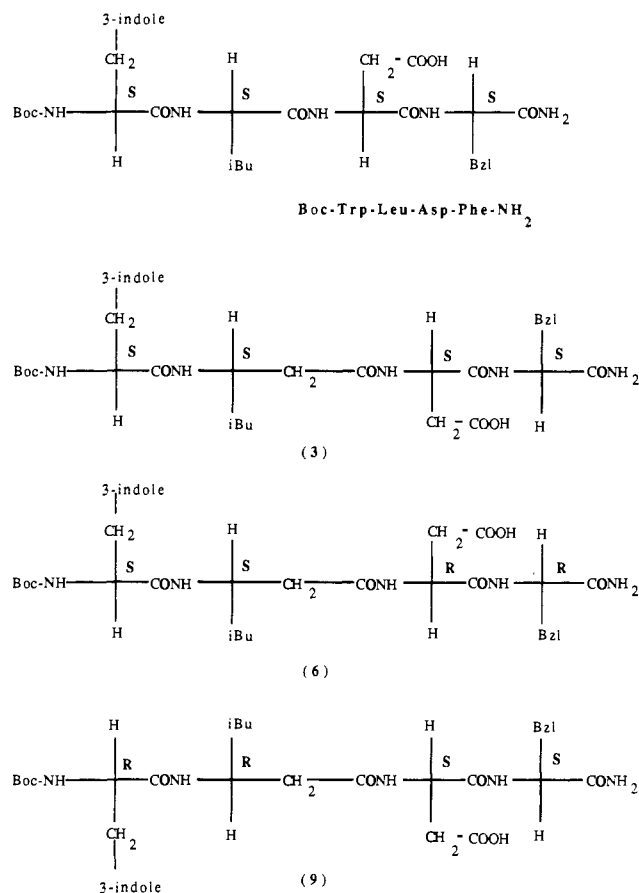

Figure 1. Schematic structure representation of Boc-Trp-Leu-Asp-Phe-NH₂ and of compounds Boc-Trp-β-homo-Leu-Asp-Phe-NH₂ (3), Boc-Trp-β-homo-Leu-D-Asp-D-Phe-NH₂ (6), and Boc-D-Trp-β-homo-D-Leu-Asp-Phe-NH₂ (9).

general tetragastrin side chain orientation. From the parent structure Boc-Trp-Leu-Asp-Phe-NH₂, we synthesized, for instance, Boc-Trp-β-homo-Leu-Asp-Phe-NH₂ (3) and its diastereoisomers Boc-Trp-β-homo-Leu-D-Asp-D-Phe-NH₂ (6) and Boc-D-Trp-β-homo-D-Leu-Asp-Phe-NH₂ (9) (compounds 6 and 9 are enantiomers). We describe in the Experimental Section only the syntheses of compounds 2 (Scheme I) and 12 (Scheme IV), which are representative of the methods used in this work. Z-β-homo-Leu (18) was synthesized according to the method of Wakamiya et al. Partial deprotection of Boc-Asp(OBzl)-NHCH₂CH₂C₆H₅⁸ with TFA, followed by coupling to Z-β-homo-Leu with BOP¹³ as coupling reagent, afforded Z-β-homo-Leu-Asp(OBzl)-NHCH₂CH₂C₆H₅ (20). This compound was deprotected by hydrogenation in acetic acid in the presence of a 10% Pd/C catalyst and allowed to react with Boc-Trp-OSu¹⁴ to yield the final partially protected compound Boc-Trp-β-homo-Leu-Asp-NHCH₂CH₂C₆H₅ (2). Z-β-homo-Asp(OBut) (32) (Scheme IV) was obtained as an oil, according to the already mentioned method, and was used for coupling as its pentachlorophenyl ester derivative (33).¹⁵ Reaction of compound 33 (Schemes I-VI) with Phe-NH₂ afforded the pseudodipeptide Z-β-homo-Asp(OBut)-Phe-NH₂ (36), which after hydrogenation and coupling with Boc-Leu-OSu,¹⁴ led to Boc-Leu-β-homo-Asp(OBut)-Phe-NH₂ (40).

(13) Castro, B.; Dormoy, J. R.; Dourtoglou, B.; Evin, G.; Selve, C.; Ziegler, C. *Synthesis* 1976, 751.

(14) Anderson, G. W.; Zimmerman, J. E.; Callahan, F. M. *J. Am. Chem. Soc.* 1964, 86, 1839.

(15) Johnson, B. J.; Trask, E. G. *J. Org. Chem.* 1968, 33, 4521.

Table I. Physical and Analytical Data of Synthetic Intermediates^a

compound	mp, °C	[α] _D , deg	R _F	Anal. C, H, N
Z- β -homo-Leu-OH (18)	55-58	-5.7	0.85 (D)	C ₁₅ H ₂₁ NO ₄
Z- β -homo-Leu-Asp(OBzl)-NHCH ₂ C ₆ H ₅ (19)	119-121	-32.2	0.64 (B), 0.85 (C)	C ₃₃ H ₃₉ N ₃ O ₆
Z- β -homo-Leu-Asp(OBzl)-NHCH ₂ CH ₂ C ₆ H ₅ (20)	145-147	-31.7	0.64 (B), 0.85 (C)	C ₃₄ H ₄₁ N ₃ O ₆
Z- β -homo-Leu-Asp(OBzl)-Phe-NH ₂ (21)	174-176	-42.1	0.17 (B), 0.41 (C)	C ₃₅ H ₄₂ N ₃ O ₇
Boc-Trp- β -homo-Leu-Asp-NHCH ₂ C ₆ H ₅ (1)	188-192	-38.6	0.73 (E), 0.41 (D)	C ₃₄ H ₄₅ N ₅ O ₇
Boc-Trp- β -homo-Leu-Asp-NHCH ₂ CH ₂ C ₆ H ₅ (2)	188-190 dec	-42.1	0.73 (E), 0.47 (D)	C ₃₅ H ₄₇ N ₅ O ₇
Boc-Trp- β -homo-Leu-Asp-Phe-NH ₂ (3)	195 dec	-51.1	0.37 (E), 0.26 (D)	C ₃₆ H ₄₈ N ₆ O ₈
Boc-D-Asp(OBzl)-NHCH ₂ C ₆ H ₅ (22)	92-94	+14.8	0.66 (A), 0.82 (B)	C ₂₃ H ₂₈ N ₂ O ₅
Boc-D-Asp(OBzl)-NHCH ₂ CH ₂ C ₆ H ₅ (23)	105-107	+14.5	0.66 (A), 0.82 (B)	C ₂₄ H ₃₀ N ₂ O ₅
Boc-D-Asp(OBzl)-D-Phe-NH ₂ (24)	138-140	+27.4	0.30 (B), 0.68 (C)	C ₂₅ H ₃₁ N ₃ O ₆
Z- β -homo-Leu-D-Asp(OBzl)-NHCH ₂ C ₆ H ₅ (25)	122-123	+15.5	0.61 (B), 0.83 (C)	C ₃₃ H ₃₉ N ₃ O ₆
Z- β -homo-Leu-D-Asp(OBzl)-NHCH ₂ CH ₂ C ₆ H ₅ (26)	127-128	+17.1	0.61 (B), 0.82 (C)	C ₃₄ H ₄₁ N ₃ O ₆
Z- β -homo-Leu-D-Asp(OBzl)-D-Phe-NH ₂ (27)	187-189	+22.1	0.15 (B), 0.61 (C)	C ₃₅ H ₄₂ N ₄ O ₇
Boc-Trp- β -homo-Leu-D-Asp-NHCH ₂ C ₆ H ₅ (4)	168-170	+10.4	0.73 (E), 0.42 (D)	C ₃₄ H ₄₅ N ₅ O ₇
Boc-Trp- β -homo-Leu-D-Asp-NHCH ₂ CH ₂ C ₆ H ₅ (5)	190-192	+10.8	0.73 (E), 0.38 (D)	C ₃₅ H ₄₇ N ₅ O ₇
Boc-Trp- β -homo-Leu-D-Asp-D-Phe-NH ₂ (6)	210 dec	+22.8	0.43 (E), 0.19 (D)	C ₃₆ H ₄₈ N ₆ O ₈
Z- β -homo-D-Leu-OH (28)	58-60	+6.2	0.85 (D)	C ₁₅ H ₂₁ NO ₄
Z- β -homo-D-Leu-Asp(OBzl)-NHCH ₂ C ₆ H ₅ (29)	146-147	-16.3	0.61 (B), 0.83 (C)	C ₃₃ H ₃₉ N ₃ O ₆
Z- β -homo-D-Leu-Asp(OBzl)-NHCH ₂ CH ₂ C ₆ H ₅ (30)	129-131	-18.7	0.61 (B), 0.82 (C)	C ₃₄ H ₄₁ N ₃ O ₆
Z- β -homo-D-Leu-Asp(OBzl)-Phe-NH ₂ (31)	187-189	-22.7	0.15 (B), 0.61 (C)	C ₃₅ H ₄₂ N ₄ O ₇
Boc-D-Trp- β -homo-D-Leu-Asp-NHCH ₂ C ₆ H ₅ (7)	175 dec	-10.3	0.72 (E), 0.48 (D)	C ₃₄ H ₄₅ N ₅ O ₇
Boc-D-Trp- β -homo-D-Leu-Asp-NHCH ₂ CH ₂ C ₆ H ₅ (8)	195 dec	-12.2	0.73 (E), 0.52 (D)	C ₃₅ H ₄₇ N ₅ O ₇
Boc-D-Trp- β -homo-D-Leu-Asp-Phe-NH ₂ (9)	215 dec	-24.5	0.42 (E), 0.26 (D)	C ₃₆ H ₄₈ N ₆ O ₈
Z- β -homo-Asp(OBzl)-OH (32)	oil		0.85 (C)	
Z- β -homo-Asp(OBzl)-OPcp (33)	58-60	+10.7	0.87 (A), 0.90 (B)	C ₂₃ H ₂₂ NO ₆ Cl ₅
Z- β -homo-Asp(OBzl)-NHCH ₂ C ₆ H ₅ (34)	138-139	-5.7	0.44 (A), 0.65 (B)	C ₂₄ H ₃₀ N ₂ O ₅
Z- β -homo-Asp(OBzl)-NHCH ₂ CH ₂ C ₆ H ₅ (35)	110-112	-5.6	0.41 (A), 0.62 (B)	C ₂₅ H ₃₂ N ₂ O ₅
Z- β -homo-Asp(OBzl)-Phe-NH ₂ (36)	184-186	-16.9	0.17 (B), 0.56 (C)	C ₂₆ H ₃₃ N ₃ O ₆
Z- β -homo-Asp(OBzl)-D-Phe-NH ₂ (37)	186-187	-2.3	0.17 (B), 0.56 (C)	C ₂₆ H ₃₃ N ₃ O ₆
Boc-Leu- β -homo-Asp(OBzl)-NHCH ₂ C ₆ H ₅ (38)	138-140	-14.2	0.67 (B), 0.76 (C)	C ₂₇ H ₄₃ N ₃ O ₆
Boc-Leu- β -homo-Asp(OBzl)-NHCH ₂ CH ₂ C ₆ H ₅ (39)	145-146	-14.9	0.63 (B), 0.69 (C)	C ₂₈ H ₄₅ N ₃ O ₆
Boc-Leu- β -homo-Asp(OBzl)-Phe-NH ₂ (40)	188-190	-25.8	0.52 (B), 0.57 (C)	C ₂₉ H ₄₈ N ₄ O ₇
Boc-Leu- β -homo-Asp(OBzl)-D-Phe-NH ₂ (41)	201-203	-11.1	0.19 (B), 0.56 (C)	C ₂₉ H ₄₈ N ₄ O ₇
Boc-Trp-Leu- β -homo-Asp-NHCH ₂ C ₆ H ₅ (10)	205 dec	-21.0	0.72 (E), 0.41 (D)	C ₃₄ H ₄₅ N ₅ O ₇
Boc-Trp-Leu- β -homo-Asp-NHCH ₂ CH ₂ C ₆ H ₅ (11)	200 dec	-20.1	0.72 (E), 0.42 (D)	C ₃₅ H ₄₇ N ₅ O ₇
Boc-Trp-Leu- β -homo-Asp-Phe-NH ₂ (12)	205 dec	-25.3	0.58 (E), 0.24 (D)	C ₃₆ H ₄₈ N ₆ O ₈
Boc-Trp-Leu- β -homo-Asp-D-Phe-NH ₂ (13)	205 dec	-14.1	0.58 (E), 0.23 (D)	C ₃₆ H ₄₈ N ₆ O ₈
Z- β -homo-D-Asp(OBzl)-OH (42)	oil		0.85 (C)	
Z- β -homo-D-Asp(OBzl)-OPcp (43)	82-84	-12.5	0.94 (B), 0.94 (E)	C ₂₃ H ₂₂ NO ₆ Cl ₅
Z- β -homo-D-Asp(OBzl)-NHCH ₂ C ₆ H ₅ (44)	141-143	+6.2	0.44 (A), 0.66 (B)	C ₂₄ H ₃₀ N ₂ O ₅
Z- β -homo-D-Asp(OBzl)-NHCH ₂ CH ₂ C ₆ H ₅ (45)	108-110	+4.0	0.41 (A), 0.62 (B)	C ₂₅ H ₃₂ N ₂ O ₅
Z- β -homo-D-Asp(OBzl)-Phe-NH ₂ (46)	175-180	+2.5	0.27 (B), 0.49 (C)	C ₂₆ H ₃₃ N ₃ O ₆
Boc-D-Leu- β -homo-D-Asp(OBzl)-NHCH ₂ C ₆ H ₅ (47)	138-140	+14.1	0.67 (B), 0.76 (C)	C ₂₇ H ₄₃ N ₃ O ₆
Boc-D-Leu- β -homo-D-Asp(OBzl)-NHCH ₂ CH ₂ C ₆ H ₅ (48)	143-144	+13.4	0.63 (B), 0.69 (C)	C ₂₈ H ₄₅ N ₃ O ₆
Boc-D-Leu- β -homo-D-Asp(OBzl)-Phe-NH ₂ (49)	187-189	+7.7	0.27 (B), 0.50 (C)	C ₂₉ H ₄₈ N ₄ O ₇
Boc-D-Trp-D-Leu- β -homo-D-Asp-NHCH ₂ C ₆ H ₅ (14)	210 dec	+17.1	0.67 (E), 0.36 (D)	C ₃₄ H ₄₅ N ₅ O ₇
Boc-D-Trp-D-Leu- β -homo-D-Asp-NHCH ₂ CH ₂ C ₆ H ₅ (15)	200 dec	+19.5	0.73 (E), 0.44 (D)	C ₃₅ H ₄₇ N ₅ O ₇
Boc-D-Trp-D-Leu- β -homo-D-Asp-Phe-NH ₂ (16)	215 dec	+14.8	0.43 (E), 0.18 (D)	C ₃₆ H ₄₈ N ₆ O ₈
Z- β -homo-Phe-OH (50)	118-120	-22.3	0.81 (E), 0.72 (D)	C ₁₈ H ₁₉ NO ₄
Z- β -homo-Phe-NH ₂ (51)	180-182	-31.1	0.17 (B), 0.61 (C)	C ₁₈ H ₂₀ N ₂ O ₃
Boc-Asp(OBzl)- β -homo-Phe-NH ₂ (52)	182-183	-32.4	0.20 (B), 0.62 (C)	C ₂₆ H ₃₃ N ₃ O ₆
Boc-Leu-Asp(OBzl)- β -homo-Phe-NH ₂ (53)	183-185	-33.3	0.17 (B), 0.62 (C)	C ₃₂ H ₄₄ N ₄ O ₇
Boc-Trp-Leu-Asp(OBzl)- β -homo-Phe-NH ₂ (54)	212-214	-31.2	0.26 (C), 0.54 (D)	C ₄₈ H ₅₄ N ₆ O ₈
Boc-Trp-Leu-Asp- β -homo-Phe-NH ₂ (17)	200 dec	-32.7	0.32 (E), 0.21 (D)	C ₃₆ H ₄₈ N ₆ O ₈

^a Experimental values of elemental analysis (C, H, N) are within 0.4% of the calculated values.

Deprotection of compound 40 with TFA and coupling to Boc-Trp-OSu produced Boc-Trp-Leu- β -homo-Asp-Phe-NH₂ (12).

Biological Activity and Discussion

Compounds 1-17 were tested for their ability to stimulate gastric acid secretion, to inhibit gastrin-induced acid secretion in the in situ perfused rat stomach,¹¹ and to inhibit the binding of [¹²⁵I]-[Nle¹¹]-HG-13 to its receptors on rabbit gastric mucosal cells. Results are summarized in Table II. None of these compounds presented any agonist activity at high doses. However, all of them were able to inhibit binding of labeled gastrin to its receptors and behaved as gastrin antagonists with various potencies.

Introducing a β -homoleucyl residue, which modifies the region of the cleavable bond between leucine and aspartic acid, resulted in gastrin antagonists (e.g. compound 3). Similarly, replacing aspartic acid or phenylalanine re-

spectively by their β -homo analogues, which modifies the structure of the C-terminal dipeptide moiety, led also to gastrin antagonists. In this series, the β -homo-aspartyl derivative Boc-Trp-Leu- β -homo-Asp-Phe-NH₂ (12) (IC₅₀ = 1.5 μ M, ED₅₀ = 0.1 mg/kg) was more potent than the β -homoleucyl and β -homophenylalanyl analogues (respectively compound 3, IC₅₀ = 10 μ M, ED₅₀ = 1.5 mg/kg, and compound 17, IC₅₀ = 50 μ M, ED₅₀ = 7 mg/kg).

In order to obtain better amino acid side chain spatial orientations and in vivo more stable derivatives, either amino acid residues following the β -homo residue (e.g. compounds 6 and 13) or amino acid residues preceding the β -homo residue and including the β -homo residue (e.g. compounds 9, 16) were replaced by their D isomers. These modifications did not produce very active analogues in β -homoleucyl derivatives, whereas they led to potent analogues in β -homoaspartyl derivatives. Particularly, compound Boc-Trp-Leu- β -homo-Asp-DPhe-NH₂, 13 (IC₅₀

Table II. Biological Activities of Synthetic β -Homo Analogues of Boc-Trp-Leu-Asp-Phe-NH₂ on in Vivo Gastrin-Induced Acid Secretion in the Rat, According to Ghosh and Schild, and on in Vitro Inhibition of Binding of Labeled Gastrin to Isolated Gastric Mucosal Cells^a

	binding (in vitro) IC ₅₀ , μ M	activity (in vivo) ED ₅₀ , mg/kg
Boc-Trp-Leu-Asp-Phe-NH ₂	0.5	agonist
Boc-Trp- β -homo-Leu-Asp-NHCH ₂ C ₆ H ₅ (1)	5	0.5
Boc-Trp- β -homo-Leu-Asp-NHCH ₂ CH ₂ C ₆ H ₅ (2)	5	0.5
Boc-Trp- β -homo-Leu-Asp-Phe-NH ₂ (3)	10	1.5
Boc-Trp- β -homo-Leu-D-Asp-NHCH ₂ C ₆ H ₅ (4)	>10	1.5
Boc-Trp- β -homo-Leu-D-Asp-NHCH ₂ CH ₂ C ₆ H ₅ (5)	2	0.8
Boc-D-Trp- β -homo-Leu-D-Asp-D-Phe-NH ₂ (6)	50	5
Boc-D-Trp- β -homo-D-Leu-Asp-NHCH ₂ C ₆ H ₅ (7)	20	5
Boc-D-Trp- β -homo-D-Leu-Asp-NHCH ₂ CH ₂ C ₆ H ₅ (8)	10	0.5
Boc-D-Trp- β -homo-D-Leu-Asp-Phe-NH ₂ (9)	100	7.5
Boc-Trp-Leu- β -homo-Asp-NHCH ₂ C ₆ H ₅ (10)	1	0.2
Boc-Trp-Leu- β -homo-Asp-NHCH ₂ CH ₂ C ₆ H ₅ (11)	0.75	0.5
Boc-Trp-Leu- β -homo-Asp-Phe-NH ₂ (12)	1.5	0.1
Boc-Trp-Leu- β -homo-Asp-D-Phe-NH ₂ (13)	2	0.1
Boc-D-Trp-D-Leu- β -homo-D-Asp-NHCH ₂ C ₆ H ₅ (14)	15	1
Boc-D-Trp-D-Leu- β -homo-D-Asp-NHCH ₂ CH ₂ C ₆ H ₅ (15)	25	2.5
Boc-D-Trp-D-Leu- β -homo-D-Asp-Phe-NH ₂ (16)	30	2.5
Boc-Trp-Leu-Asp- β -homo-Phe-NH ₂ (17)	50	7

^a Each reported value represents the means of at least four separate experiment.

= 2 μ M, ED₅₀ = 0.1 mg/kg), was as potent as Boc-Trp-Leu- β -homo-Asp-Phe-NH₂ (12) either in vitro or in vivo, these compounds being among the most potent in this series. On the other hand, Boc-D-Trp-D-Leu- β -homo-D-Asp-Phe-NH₂ (16) was about 20 times less potent than Boc-Trp-Leu- β -homo-Asp-Phe-NH₂ (12), and Boc-D-Trp- β -homo-D-Leu-Asp-Phe-NH₂ (9) was about 10 times less potent than Boc-Trp- β -homo-Leu-Asp-Phe-NH₂ (3), indicating that replacing amino acid residues preceding the β -homo residue by their D isomers and introducing a β -homo-D-residue result in analogues of decreased apparent affinity for the gastrin receptor and less potent as gastrin antagonists. However, these results also indicate that introducing D residues is probably more disturbing in β -homoleucyl than in β -homoaspartyl analogues.

In those analogues containing β -homoleucyl or β -homoaspartyl residues, we studied the effects of replacing phenylalanine amide by 2-phenylethylamine, substitution which was found interesting in other series,⁸ or by benzylamine, in order to keep a proper distance between the indole of tryptophan and the aromatic moiety. 2-Phenylethylamine derivatives containing a β -homoaspartyl residue are almost as potent as their phenylalanine amide analogues, either in vivo or in vitro (compound 15 \approx compound 16, compound 11 \approx compound 12). 2-Phenylethylamide derivatives of β -homoleucyl derivatives (compounds 2, 5, and 8) are more potent than their phenylalanine amide analogues (compound 2 > compound 3, compound 5 > compound 6, compound 8 > compound 9). Replacement of phenylalanine amide by benzylamine does not seem to be of great importance in β -homoaspartyl derivatives and leads to compounds (10, 14) of quite similar potency. This change produces compounds (1, 4, and 7) of similar or decreased activity in β -homoleucyl analogues as compared with their corresponding phenylalanine amide or 2-phenylethylamide derivatives, the order of potency being compound 1 = compound 2 > compound 3, compound 5 > compound 4 > compound 6, compound 8 > compound 7 > compound 9.

Replacement of phenylalanine amide by β -homo-phenylalanine amide (compound 17) resulted in a not very active compound.

It is interesting to notice, however, that there is a satisfactory correlation between affinity for the receptors and antagonist activity in this series.

Conclusion

Taken together, these results seem to indicate that introduction of an extra methylene group (e.g. β -homoleucyl or β -homoaspartyl residues) in the structure of the tetragastrin analogue Boc-Trp-Leu-Asp-Phe-NH₂ does not dramatically disturb the general conformation of the molecule in terms of gastrin receptor recognition, but produces gastrin antagonists. In fact, this modification closely induces the same effects on biological activity as the retro-inverso modifications presented in a preceding paper.¹⁰

This work demonstrates that chemical modifications which affect the region of the methionine (or leucine)-aspartic acid peptide bond and which may influence the enzymatic stability of this bond and/or the structure of the C-terminal dipeptide moiety produce gastrin antagonists. However, the stability of these derivatives toward the enzymatic system present in membrane gastric mucosal cells remains to be determined.

Experimental Section

Melting points were taken on a Büchi apparatus in open capillary tubes. Optical rotations were determined with a Perkin-Elmer 141 polarimeter. Elemental analyses were performed by Le Service de Microanalyses de l'ENSCM (Montpellier, France). ¹H NMR spectra were recorded on a Brüker 360 instrument in DMSO-*d*₆ at 293 K. Ascending TLC was performed on precoated plates of silica gel 60 F 254 (Merck) with use of the following solvent systems (by volume): A, AcOEt/hexane 5:5; B, AcOEt/hexane, 7:3; C, AcOEt; D, chloroform/methanol/acetic acid, 85:10:5; E, AcOEt/pyridine/acetic acid/water, 80:20:3:3. Peptide derivatives were located with UV light (254 nm), charring reagent or ninhydrin. Column chromatographies were performed with silica gel 60, 60–229 mesh, ASTM (Merck). L-Amino acids and derivatives were purchased from Bachem. All reagents and solvents were of analytical grade. BOP was recrystallized from acetone and ether. The following abbreviations were used: DMF, dimethylformamide; HOBT, 1-hydroxybenzotriazole; DIEA, *N,N*-diisopropylethylamine; BOP, (benzotriazolyl)tris(dimethylamino)phosphonium hexafluorophosphate; NMM, *N*-methylmorpholine; IBCF, isobutyl chloroformate; DCC, dicyclohexylcarbodiimide. Other abbreviations used were those recommended by the IUPAC-IUB Commission (*Eur. J. Biochem.* 1984, 138, 9–37).

Syntheses. The peptides described herein were synthesized according to the general procedures detailed in this section for the preparation of compounds 2 and 12, unless otherwise stated. All compounds used for biological tests were dissolved in 0.1 N NH₄OH, filtered on millipore (0.45 μ m), and lyophilized. The purity of lyophilized compounds was checked again by TLC. Analytical and physical data of the synthesized compounds are reported in Table I.

(Benzyloxycarbonyl)- β -homo-L-leucine (18). To a cold (–20 °C) solution of (benzyloxycarbonyl)-L-leucine (5.2 g, 20 mmol) in 50 mL of ethylene glycol dimethyl ether were added under vigorous stirring NMM (2.2 mL, 20 mmol) and IBCF (2.72 mL, 20 mmol). After 5 min, the precipitated salt was filtered off, and the mixture was treated with diazomethane in ether (30 mmol), with stirring at 0 °C for 20 min. The reaction mixture was then concentrated in vacuo, and the residue was dissolved in methanol (100 mL) and treated with silver benzoate (1 g, 4 mmol) in triethylamine (10 mL). After 30 min of stirring at room temperature, the solvent was concentrated in vacuo, the residue was dissolved in AcOEt (100 mL), and insoluble material was removed by filtration. The filtrate was washed with a saturated sodium bicarbonate solution (3 \times 100 mL), water (100 mL), 1 M aqueous KHSO₄ (3 \times 100 mL), brine, dried over magnesium sulfate, and concentrated in vacuo.

The crude methyl ester was dissolved in methanol (20 mL) and treated with 2 N NaOH (10 mL) at 30 °C for 30 min. The solvent

was removed in vacuo, the residue was dissolved in water (80 mL), and the solution was washed with ether (3 × 80 mL). Upon acidification of the aqueous phase with 1 M aqueous KHSO₄, the expected compound precipitated. It was collected by filtration, washed thoroughly with water, and dried in vacuo; yield 3.63 g (65%). Physical data are reported in Table I.

(Benzylloxycarbonyl)-β-homo-L-leucyl-β-benzyl-L-aspartic Acid 2-Phenylethylamide (20). (*tert*-Butyloxycarbonyl)-β-benzyl-L-aspartic acid 2-phenylethylamide⁸ (1 g, 2.34 mmol) was dissolved in TFA (15 mL). After standing at room temperature for 30 min, the mixture was concentrated, and the residue was dried overnight in vacuo over KOH pellets. It was then dissolved in DMF (10 mL) containing compound 18 (0.653 g, 2.34 mmol) and BOP¹³ (1.03 g, 2.34 mmol). The solution was cooled in an ice bath, and NMM (0.51 mL, 4.68 mmol) was added. After 1 h of stirring at room temperature, the expected compound precipitated upon addition of 5% aqueous NaHCO₃ (100 mL). It was collected by filtration, washed with water, 1 M aqueous KHSO₄, and water, and dried in vacuo; yield 1.25 g (91%). Physical data are reported in Table I.

(*tert*-Butyloxycarbonyl)-L-tryptophyl-β-homo-L-leucyl-L-aspartic Acid 2-Phenylethylamide (2). Compound 20 (1.0 g, 1.7 mmol) was hydrogenated in acetic acid (30 mL) in the presence of a 10% Pd/C catalyst for 5 h at room temperature and atmospheric pressure. After removal of the catalyst by filtration and concentration of the solvent, the residue was triturated in ether and dried in vacuo over KOH pellets. It was then dissolved in DMF (10 mL) containing (*tert*-butyloxycarbonyl)-L-tryptophan succinimido ester¹⁴ (0.642 g, 1.6 mmol). The solution was cooled in an ice bath, and DIEA (0.30 mL, 1.7 mmol) was added. After 1 h of stirring at room temperature, the expected compound precipitated upon addition of 1 M aqueous KHSO₄ (100 mL). It was collected by filtration, washed with 1 M aqueous KHSO₄ and water, and dried in vacuo; yield 0.83 g (80%). Physical data are given in Table I.

(Benzylloxycarbonyl)-β-homo-L-aspartic Acid β-*tert*-Butyl Ester (32). This compound was synthesized according to the procedure described for compound 18. It was obtained as an oil; yield 75%.

(Benzylloxycarbonyl)-β-homo-L-aspartic Acid α-Pentachlorophenyl Ester β-*tert*-Butyl Ester (33). Compound 32 (2.3 g, 6.81 mmol) was dissolved in dichloromethane (50 mL) containing pentachlorophenol (1.86 g, 7.0 mmol). The solution was cooled in an ice bath, and DCC (1.4 g, 6.8 mmol) was added. After 2 h of stirring at 0 °C, the precipitated DCU was filtered off, and the filtrate was concentrated in vacuo. The solid residue was recrystallized in hexane; yield 2.87 g (72%). Physical data are reported in Table I.

(Benzylloxycarbonyl)-β-homo-L-aspartyl-L-phenylalaninamide β-*tert*-Butyl Ester (36). Compound 33 (0.586 g, 1.0 mmol) was dissolved in DMF (4 mL, containing L-phenylalaninamide (0.197 g, 1.2 mmol), and the mixture was stirred for 3 h at room temperature. The solvent was concentrated in vacuo, and the residue was triturated with ether, collected by filtration, washed with 1 M aqueous KHSO₄, water, 5% aqueous NaHCO₃, and water, and dried in vacuo to afford the expected compound; yield 0.36 g (75%). Physical data are reported in Table I.

(*tert*-Butyloxycarbonyl)-L-leucyl-β-homo-L-aspartyl-L-phenylalaninamide β-*tert*-Butyl Ester (40). Compound 36 (0.29 g, 0.60 mmol) was hydrogenated in a mixture of ethanol and acetic acid (9:1; 20 mL) as described for compound 2. The partially deprotected peptide was dissolved in DMF (4 mL) containing (*tert*-butyloxycarbonyl)-L-leucine succinimido ester¹⁴ (0.181 g, 0.55 mmol). The solution was cooled in an ice bath, and DIEA (0.10 mL, 0.6 mmol) was added. After 1 h of stirring at room temperature, the expected compound precipitated upon addition of 1 M aqueous KHSO₄ (100 mL). It was collected by filtration, washed with 1 M aqueous KHSO₄ and water, and dried in vacuo; yield 0.26 g (84%). Physical data are reported in Table I.

(*tert*-Butyloxycarbonyl)-L-tryptophyl-L-leucyl-β-homo-L-aspartyl-L-phenylalaninamide (12). Compound 40 (0.2 g, 0.355 mmol) was dissolved in TFA (5 mL). After the mixture was allowed to stand for 30 min at room temperature, the deprotected peptide was precipitated by addition of ether; it was collected and dried overnight in vacuo over KOH pellets. The deprotected peptide was then dissolved in DMF (3 mL) containing (*tert*-bu-

tyloxycarbonyl)-L-tryptophan succinimido ester¹⁴ (0.136 g, 0.34 mmol). The solution was cooled in an ice bath, and DIEA (0.06 mL, 0.355 mmol) was added. After 1 h of stirring at room temperature, the expected compound precipitated upon addition of 1 M aqueous KHSO₄ (40 mL). It was collected by filtration, washed with 1 M aqueous KHSO₄ and water, and dried in vacuo; yield 0.21 g (85%). Physical data are reported in Table I.

Biological Tests. Gastric acid secretion was determined in vivo in the reperforated rat stomach according to the method of Ghosh and Schild.¹¹ The gastric pouch of an anesthetized rat (urethane ip) was continuously washed at 30 °C with a propionate succinate solution. The cumulative pH was recorded with time and used as an index of acid secretion. Synthetic (Leu¹⁵)-human gastrin I (gift from Prof. E. Wunsch, Max Planck Institute, München) and compounds 1–17 were dissolved in 0.9% NaCl and bolus injected intravenously. The amount of secreted H⁺ was determined by the pH difference between stimulated and basal recorded traces. The inhibitory effect of synthetic peptides was measured after simultaneous bolus injection of the compounds in water alkaline solution and of gastrin (80 pmol was usually employed). The amount of H⁺ secreted in the presence of various doses of the peptides was related to the amount of H⁺ secreted after gastrin alone and expressed as percent of inhibition. The mean H⁺ secretion after gastrin injection was 203 ± 28 mmol of H⁺/nmol of peptide (*n* = 17).

Binding Studies. Isolation of rabbit gastric cells was carried out by the collagenase/EDTA procedure described.¹⁶ Fundic mucosa was scraped, and the tissues were chopped into small cubes and then dispersed in medium A (132 mM NaCl, 5.4 mM KCl, 5 mM Na₂HPO₄, 1 mM NaH₂PO₄, 1.2 mM MgSO₄, 1 mM CaCl₂, 25 mM Hepes, 0.2% glucose, 0.2% bovine serum albumin, 0.02% phenol red, pH 7.4) (gassed O₂/CO₂) containing 0.30 mg/mL collagenase. After a 15-min incubation at 37 °C, tissue fragments were allowed to settle, and the medium was discarded. The fragments were washed with Ca²⁺-free medium A containing 2 mM EDTA and then incubated in the same medium for 10 min. The fragments were transferred to medium A containing fresh 0.30 mg/mL collagenase and incubated for 15 min at 37 °C with continuous gassing (O₂/CO₂). The cell suspension was centrifuged for 15 min at 200g and then washed twice with medium A. This procedure gave about 5 × 10⁷ cells/g of wet mucosa with 95% viability (trypan blue exclusion). The mixed population contained 45% parietal cells. (Nle¹¹)-HG-13 was iodinated according to a modification of the already described chloramine T procedure.¹⁶ After purification by DE-52 ion-exchange chromatography, the monoiodinated peptide was obtained with full biological activity. Specific gastrin binding was determined by incubation in medium B (Earle's balanced salt medium without bicarbonate and containing 10 mM Hepes and 0.2% BSA, pH 7.4) of 20 pM labeled (Nle¹¹)-HG-13 (≈40 000 cpm/mL) for 30 min at 37 °C with 5 × 10⁶ cells/mL ± various concentrations of peptides or unlabeled (Nle¹¹)-HG-13. Nonsaturable binding was determined as the amount of radioactivity associated with cells in the presence of 1 × 10⁻⁶ M cold (Nle¹¹)-HG-13.

Registry No. 1, 118247-61-3; 2, 118247-62-4; 3, 118247-63-5; 4, 118333-35-0; 5, 118333-36-1; 6, 118333-37-2; 7, 118333-38-3; 8, 118333-39-4; 9, 118333-40-7; 10, 118247-64-6; 11, 118247-65-7; 12, 118247-66-8; 13, 118333-41-8; 14, 118333-42-9; 15, 118333-43-0; 16, 118333-44-1; 17, 118247-67-9; 18, 118247-68-0; 19, 118247-69-1; 20, 118247-70-4; 21, 118247-71-5; 22, 118247-72-6; 23, 118247-73-7; 24, 118247-74-8; 25, 118247-75-9; 26, 118247-76-0; 27, 118333-45-2; 28, 118247-77-1; 29, 118247-78-2; 30, 118247-79-3; 31, 118333-46-3; 32, 83436-45-7; 33, 118247-80-6; 34, 118247-81-7; 35, 118247-82-8; 36, 118247-83-9; 37, 118247-84-0; 38, 118247-85-1; 39, 118247-86-2; 40, 118247-87-3; 41, 118333-47-4; 42, 118247-88-4; 43, 118247-89-5; 44, 118247-90-8; 45, 118247-91-9; 46, 118247-92-0; 47, 118247-93-1; 48, 118247-94-2; 49, 118333-48-5; 50, 26250-86-2; 51, 118247-95-3; 52, 118247-96-4; 53, 118247-97-5; 54, 118247-98-6; Z-Leu-OH, 2018-66-8; Z-Leu-CH=N₂, 102123-81-9; Z-β-homo-Leu-OMe, 96386-94-6; BOC-Asp(OBzl)-NHCH₂CH₂Ph, 108279-08-9; H-Asp(OBzl)-NHCH₂CH₂Ph-TFA, 108279-24-9; BOC-Trp-OSu, 3392-11-8; H-β-homo-Leu-Asp-NHCH₂CH₂Ph, 118247-99-7; BOC-D-Asp(OBzl)-OH, 51186-58-4; Z-D-Leu-OH, 28862-79-5;

Z-D-Leu-CH=N₂, 118248-00-3; Z-β-homo-D-Leu-OMe, 118248-01-4; BOC-D-Trp-OSu, 22220-11-7; Z-Asp(OBu-*t*-)-OH, 5545-52-8; Z-Asp(OBu-*t*-)-CH=N₂, 118248-02-5; Z-β-homo-Asp(OBu-*t*-)-OMe, 83436-44-6; BOC-Leu-OSu, 3392-09-4; H-Leu-β-homo-Asp-Phe-NH₂·TFA, 118248-04-7; Z-D-Asp(OBu-*t*-)-OH, 71449-08-6; Z-D-Asp(OBu-*t*-)-CH=N₂, 118248-05-8; Z-β-homo-D-Asp(OBu-*t*-)-OMe, 118248-06-9; BOC-D-Leu-OSu, 60111-76-4; Z-Phe-OH, 1161-13-3;

Z-Phe-CH=N₂, 15196-02-8; Z-β-homo-Phe-OMe, 97206-05-8; BOC-Asp(OBzl)-OH, 7536-58-5; BOC-Leu-OH, 13139-15-6; H-Phe-NH₂, 5241-58-7; gastrin, 9002-76-0.

Supplementary Material Available: Tables of ¹H NMR data and assignments for compounds 1-17 (11 pages). Ordering information is given on any current masthead page.

3-Aminopyridazine Derivatives with Atypical Antidepressant, Serotonergic, and Dopaminergic Activities

Camille-Georges Wermuth,^{*,†} Gilbert Schlewer,[†] Jean-Jacques Bourguignon,[†] Georges Maghioros,[†] Marie-Jeanne Bouchet,[†] Claudine Moire,[†] Jean-Paul Kan,[†] Paul Worms,[†] and Kathleen Biziere^{‡,§}

Departement de Pharmacochimie Moléculaire, Centre de Neurochimie du CNRS, Université Louis Pasteur, 67084 Strasbourg Cedex, France, and Sanofi Recherche, 34082 Montpellier Cedex, France. Received May 23, 1988

Minaprine [3-[(β-morpholinoethyl)amino]-4-methyl-6-phenylpyridazine dihydrochloride] is active in most animal models of depression and exhibits in vivo a dual dopaminomimetic and serotoninomimetic activity profile. In an attempt to dissociate these two effects and to characterize the responsible structural requirements, a series of 47 diversely substituted analogues of minaprine were synthesized and tested for their potential antidepressant, serotonergic, and dopaminergic activities. The structure-activity relationships show that dopaminergic and serotonergic activities can be dissociated. Serotonergic activity appears to be correlated mainly with the substituent in the 4-position of the pyridazine ring whereas the dopaminergic activity appears to be dependent on the presence, or in the formation, of a para-hydroxylated aryl ring in the 6-position of the pyridazine ring.

Minaprine [3-[(β-morpholinoethyl)amino]-4-methyl-6-phenylpyridazine dihydrochloride, 1] is a psychotropic drug that we synthesized¹ in continuation of our research on pyridazine derivatives.²⁻¹⁰ In rodents, minaprine is active in most animal models of depression, is devoid of anticholinergic activity, and does not modify locomotor activity.¹¹⁻¹³ In humans, minaprine is well tolerated and has been shown to be more effective than placebo and equally efficient to maprotiline and nomifensine in the treatment of depressive disorders.¹⁴⁻¹⁸ Minaprine is presently being extensively investigated as an antidepressant in most European countries and in the United States.

Biochemical and pharmacological studies show that in vivo minaprine enhances both serotonergic and dopaminergic transmission, but does not affect noradrenergic transmission.^{11,19-22} In vitro, however, minaprine does not affect the uptake, the release, or the metabolism of serotonin and dopamine and does not interact with serotonin or dopamine receptors.^{13,19-21} Thus, the mechanism(s) through which minaprine exhibits this dual serotoninomimetic and dopaminomimetic effect remain(s) unclear. Another question also arises, which is to investigate whether or not it is possible to dissociate these two effects by modifying the chemical structure of minaprine, and which are the structural requirements for each one of these effects.

In an attempt to approach these problems, we synthesized series of analogues of minaprine that were tested for their potential antidepressant, serotonergic, and dopaminergic activities. The main modifications concerned the basic side chain, the substituents in the 4-position of the pyridazine ring, and the exploration of the role and substitutions of the phenyl ring in the 6-position.

Chemistry

The two dominant aspects that characterized the synthesis of 3-[(aminoalkyl)amino]pyridazines were the creation of the pyridazinone ring, properly substituted in

Scheme I. Synthesis of Minaprine, a Generalizable Example for the Synthesis of 4,6-Disubstituted Analogues

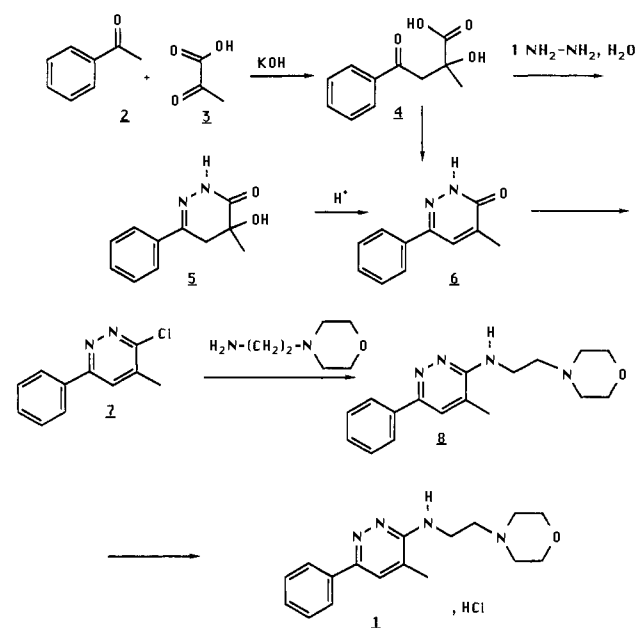

positions 4 and 6, and the subsequent branching of the basic side chain. The original synthesis of minaprine

- (1) Wermuth, C. G.; Exinger, A. *Agressologie* 1972, 13, 285.
- (2) Wermuth, C. G. *Agressologie* 1965, 6, 383.
- (3) Laborit, H.; Wermuth, C. G.; Leterrier, F.; Baron, C. *Agressologie* 1965, 6, 401.
- (4) Laborit, H.; Weber, B.; Baron, C.; Delbarre, B.; Pavlovichova, H. *Agressologie* 1965, 6, 463.
- (5) Laborit, H.; Wermuth, C. G.; Weber, B.; Delbarre, B.; Chekler, C.; Baron, C.; Rosengarten, H. *Agressologie* 1965, 6, 415.
- (6) Leclerc, G.; Wermuth, C. G.; Schreiber, J. *Bull. Soc. Chim. Fr.* 1967, II, 1302.
- (7) Leclerc, G.; Wermuth, C. G. *Bull. Soc. Chim. Fr.* 1967, II, 1307.
- (8) Wermuth, C. G. *Eur. J. Med. Chem. (Chim. Ther.)* 1967, 2, 130.
- (9) Wermuth, C. G.; Leclerc, G.; Melounou, P. *Eur. J. Med. Chem. (Chim. Ther.)* 1970, 5, 141.
- (10) Wermuth, C. G.; Leclerc, G. *Eur. J. Med. Chem. (Chim. Ther.)* 1970, 5, 243.

[†] Département de Pharmacochimie Moléculaire.

[‡] Sanofi Recherche.

[§] Present address: F. Hoffmann-La Roche and Co. Ltd., CH 4002 Basel, Switzerland.