

specific binding was defined as that in the presence of either 1  $\mu\text{M}$  (+)-butaclamol or 10 M *S*-sulpiride (RBI).

The dissociation constants,  $K_i$  values, were obtained by the program LIGAND (see refs 4 and 23) using a value of 0.17 nM as the dissociation constant for [ $^3\text{H}$ ]SCH 23390 at D1 and a value of 0.06 nM as the dissociation constant for [ $^3\text{H}$ ]piperone at D2.

**Registry No.** 1, 55-81-2; 2, 96-09-3; 3, 137464-85-8; 4, 137566-51-9; 4-HCl, 137566-52-0; 5, 137464-86-9; 6, 137464-87-0; 6 free base, 137464-88-1; 7, 137566-53-1; 8, 137566-54-2; 9, 137464-89-2; 9 free base, 137464-90-5; 10, 7569-58-6; 11, 7569-87-1; 12, 84384-03-2; 13, 73445-60-0; 14, 137464-91-6; 15, 137464-92-7; 15 free base, 137464-93-8; allyl bromide, 106-95-6.

## Synthesis and Biological Activity of New Dimers in the 7*H*-Pyrido[4,3-*c*]carbazole Antitumor Series

C. Garbay-Jaureguierry, M. C. Barsi, A. Jacquemin-Sablon,<sup>†</sup> J. B. Le Pecq,<sup>‡</sup> and B. P. Roques\*

Département de Chimie Organique, U266 INSERM—UA498 CNRS, 4, avenue de l'Observatoire, 75270 Paris Cedex 06, France, Unité de Physicochimie Macromoléculaire, UA158 CNRS—U140 INSERM, Institut G. Roussy-Villejuif, France, and Rhône Poulenc Rorer 13, quai Jules Guesdes-94400 Vitry/Seine. Received April 8, 1991

Ditercalinium (NSC 366241) is a 7*H*-pyrido[4,3-*c*]carbazole dimer with a diethylbipiperidine rigid chain linking the two heterocyclic rings. Ditercalinium is characterized by a high DNA affinity and bisintercalating ability, associated with potent antitumor properties, involving an original mechanism of action. Unfortunately as ditercalinium is hepatotoxic, its clinical evaluation has been interrupted. In order to eliminate or at least minimize the serious drawbacks related to its toxic effects, several chemical modifications have been made to the structure of ditercalinium, and their influence has been evaluated by measuring the DNA affinities, intercalation properties, and toxicity toward leukemia cells of the newly synthesized dimers. Reduction of the pyridinic moieties of ditercalinium, in order to suppress the permanent charges provided by the quaternizing chain, led to an almost complete loss of activity, although the DNA bisintercalating property of the dimer was preserved. Dimerization of the 7*H*-pyrido[4,3-*c*]carbazole rings by introduction of the rigid spacer on the  $N_7$ - or  $C_6$ -positions corresponding to the convex face of the pyridocarbazole, instead of the  $N_2$ -position in ditercalinium, led to DNA bisintercalating dimers practically devoid of antitumor properties. However after quaternarization of the  $N_2$  atoms, the dimer linked by the  $N_7$  atoms exhibited a very high DNA affinity ( $>10^9 \text{ M}^{-1}$ ) and recovered antitumor activity, supporting the requirement of positive charges for the emergence of antitumor activity in these dimers. Introduction on the  $C_6$  of the 7*H*-pyridocarbazole ring of an aminomethyl or carboxyl group, a sugar residue, or C or N free amino acids such as Lys or Glu has also been carried out, in order to increase the hydrophilic properties of the molecules or to enable them to use amino acid transport systems. Although some of these compounds were active, none of them exhibited the pharmacological potency of ditercalinium.

### Introduction

Ditercalinium (NSC 366 241), a DNA bisintercalating 7*H*-pyrido[4,3-*c*]carbazole dimer,<sup>1,2</sup> behaves as a new type of antitumor drug characterized by an original mechanism of action.<sup>3-9</sup> It binds to DNA with high affinity and elicits antitumor activity on a variety of animal tumors. Ditercalinium has also been shown to be cytotoxic on *Escherichia coli polA* mutants and not on *polA uvrA* double mutants.<sup>6</sup> Since the dimer binds reversibly, it has been suggested that it could induce, in vivo, DNA conformational changes recognized by the *uvrABC* repair system in *E. coli*. This feature could lead to a futile and abortive DNA repair process with subsequent cytotoxic effects.<sup>6-8</sup> Extensive NMR studies of the complexes formed between ditercalinium and autocomplementary oligonucleotides have shown that it bisintercalates into the major groove of the DNA helix.<sup>10-12</sup> This situation is rarely encountered for mono- or even bisintercalators, as illustrated with quinoxaline antibiotic dimers which were shown to have their spacer located in the minor groove.<sup>13</sup> Because of the rigidity of the linking chain of ditercalinium, the DNA conformation has to be altered to permit the intercalation of the two rings. NMR studies and theoretical calculations have shown that this can be achieved by a slight bending of the DNA toward the minor groove,<sup>14</sup> a result recently confirmed by X-ray analysis.<sup>15</sup>

As the nature of the complex formed between ditercalinium and DNA appears to play a crucial role in its biological activity, modifications of the structure of the

dimer have been extensively investigated.<sup>16-20</sup> Thus, displacement of the nitrogen from position 2 in the 7*H*-

- (1) Roques, B. P.; Le Guen, L.; Porcher, G.; Goss, C.; Le Pecq, J. B. DNA bifunctional intercalators: Antileukemic activity of new pyridocarbazole dimers. *Biochem. Pharmacol.* 1979, 28, 1811-1815.
- (2) Pelaprat, D.; Delbarre, A.; Le Guen, I.; Roques, B. P.; Le Pecq, J. B. DNA intercalating compounds as potential antitumor agents: II. Preparation and properties of 7*H*-pyridocarbazole dimers. *J. Med. Chem.* 1980, 23, 1336-1343.
- (3) Esnault, C.; Roques, B. P.; Jacquemin-Sablon, A.; Le Pecq, J. B. Effects of new antitumor bifunctional intercalators derived from 7*H*-pyridocarbazole on sensitive and resistant L1210 cells. *Cancer Res.* 1984, 44, 4335-4360.
- (4) Markovits, J.; Pommier, Y.; Mattern, M. R.; Roques, B. P.; Le Pecq, J. B.; Kohn, K. W. Effects of the bifunctional antitumor intercalator ditercalinium on DNA in mouse leukemia L1210 cells and DNA topoisomerase II. *Cancer Res.* 1986, 46, 5821-5826.
- (5) Esnault, C.; Lambert, B.; Markovits, J.; Segal-Bendirdjian, E.; Muzard, G.; Garbay-Jaureguierry, C.; Roques, B. P.; Le Pecq, J. B. Mechanisms of the antitumor action of ellipticines, isoellipticines and analogues: Comparison of mono and bifunctional intercalators. In *Molecular Mechanisms of Carcinogenic and Antitumor Activity*; Chagas, C., Pullman, B., Eds.; Adenine Press: Schenectady, NY, 1987; pp 295-316.
- (6) Lambert, B.; Roques, B. P.; Le Pecq, J. B. Induction of an abortive and futile DNA repair process in *E. coli* by the antitumor DNA bifunctional intercalator ditercalinium: Role of *polA* in death induction. *Nucleic Acid Res.* 1988, 16, 1063-1078.
- (7) Lambert, B.; Roques, B. P.; Jones, A.; Le Pecq, J. B.; Yeung, T. The non-covalent complex between DNA and the bifunctional intercalator ditercalinium is a substrate for the *uvrABC* endonuclease of *Escherichia coli*. *Proc. Natl. Acad. Sci. U.S.A.* 1989, 86, 6557-6561.

\* To whom reprint request should be addressed.

<sup>†</sup> Unité de Physicochimie Macromoléculaire.

<sup>‡</sup> Rhône Poulenc Rorer.

Scheme I. (A) Synthesis of a Tetrahydropyridinic Analogue of Ditercalinium, (B) Synthesis of Dimer di-6, and (C) Synthesis of Dimers di-7 and di-7b

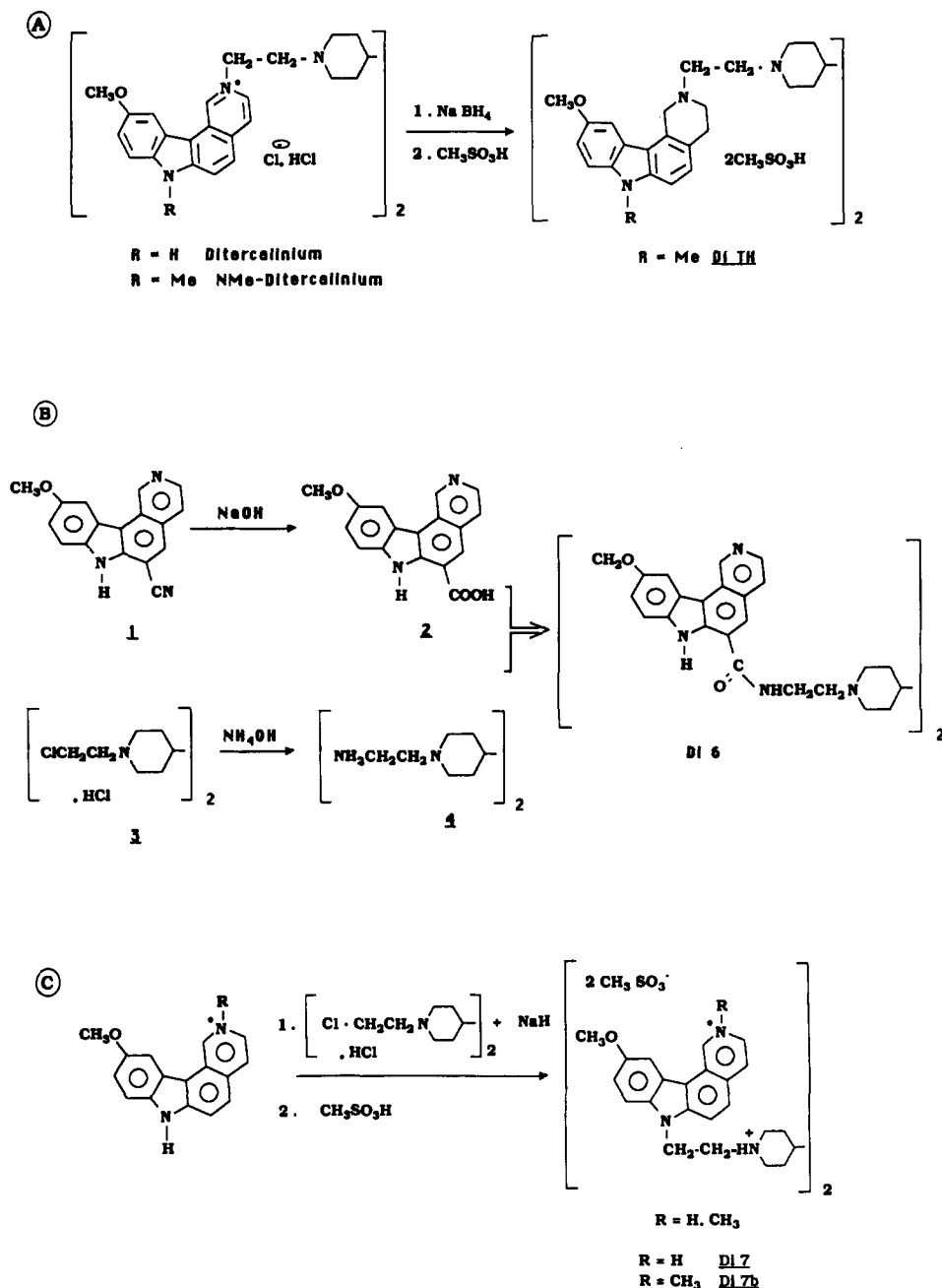

pyridocarbazole ring to the three other possible positions in the pyridine ring led to an almost complete loss of

antitumor properties.<sup>19</sup> Moreover, the length and the rigidity of the chain connecting the two 7H-pyridocarbazole

- (8) Lambert, B.; Segal-Bendirdjian, E.; Esnault, C.; Le Pecq, J. B.; Roques, B. P.; Jones, B.; Yeung, A. T. Recognition by the DNA repair system of DNA structural alterations induced by reversible drug-DNA interactions. *Anticancer Drug Des.* 1990, 5, 43-53.
- (9) Segal-Bendirdjian, E.; Coulaud, D.; Roques, B. P.; Le Pecq, J. B. Selective loss of mitochondrial DNA after treatment of cells with ditercalinium (NSC 335153), an antitumor bis-intercalating agent. *Cancer Res.* 1988, 48, 4982-4992.
- (10) Delbarre, A.; Delepierre, M.; Garbay-Jaureguiberry, C.; Igolen, J.; Le Pecq, J. B.; Roques, B. P. Geometry of the antitumor drug ditercalinium bisintercalated into d(CpGpCpG)<sub>2</sub> by <sup>1</sup>H NMR. *Proc. Natl. Acad. Sci. U.S.A.* 1987, 84, 2155-2159.
- (11) Delbarre, A.; Delepierre, M.; Langlois d'Estaintot, B.; Igolen, J.; Roques, B. P. Bis-intercalation of ditercalinium into a d-(CpGpCpG)<sub>2</sub> minihelix: Structure and dynamics aspect. A 400 MHz <sup>1</sup>H NMR study. *Biopolymers* 1987, 26, 1001-1033.
- (12) Delepierre, M.; Maroun, R.; Garbay-Jaureguiberry, C.; Igolen, J.; Roques, B. P. <sup>1</sup>H and <sup>31</sup>P nuclear magnetic resonance studies of the differences in DNA deformation induced by antitumoral 7H-pyrido[4,3-c]carbazole dimers. *J. Mol. Biol.* 1989, 210, 211-228.
- (13) Wang, A. J.; Uguetto, G.; Quickley, G. J.; Hakoshima, T.; Van der Marel, G. A.; Von Boom, J. H.; Rich, A. The molecular structure of a DNA-triostin A complex. *Science* 1984, 225, 1115-1121.
- (14) Maroun, R.; Delepierre, M.; Roques, B. P. Intercalative binding of ditercalinium to d(CpGpCpG)<sub>2</sub>: A theoretical study. *J. Biomol. Struct. Dyn.* 1989, 7, 1-44.
- (15) Gao, Q.; Williams, L. D.; Egli, M.; Rabinovitch, D.; Chen, S. L.; Quigley, G. J.; Rich, A. Drug induced DNA repair: X-ray structure of a DNA-ditercalinium complex. *Proc. Natl. Acad. Sci. U.S.A.* 1991, 88, 2422-2426.

rings which induce bisintercalation with one excluded site, associated with appropriate deformation of the DNA structure, have been demonstrated to be essential for pharmacological activity.<sup>16,20</sup> On the other hand, in mammalian tumor cells, ditercalinium was shown to be essentially concentrated in the mitochondria, where it seems to cause the degradation of mitochondrial DNA,<sup>9</sup> a property shared by other charged molecules such as dequalinium,<sup>21</sup> a topical antimicrobial agent which displays anticarcinoma activity. These results are in agreement with recent reports underlying frequent alterations of mitochondria in carcinoma cells,<sup>22</sup> suggesting that this organelle could be a specific target for antitumor drugs. Unfortunately, high concentrations of ditercalinium were also found in hepatocyte mitochondria, very likely accounting for its hepatotoxicity,<sup>23</sup> which caused the clinical trials of this molecule to be abandoned. Thus, our goal was to obtain antitumor dimers endowed with low hepatotoxicity on the basis of structural modifications and/or an improvement in pharmacokinetic properties. This has already been achieved for CC1065, a DNA-groove binder characterized by a high DNA affinity and a delayed toxicity, which has been chemically modified to decrease the severe hepatotoxic secondary effects<sup>24</sup> while preserving its high antitumor activity.<sup>25</sup> In the first part of this paper, we report

the synthesis and biological activity of new 7*H*-pyrido[4,3-*c*]carbazole dimers in which the two aromatic rings have been linked by means of their convex face [position C<sub>6</sub> (**di-6**) or N<sub>7</sub> (**di-7**)] instead of the concave face as in ditercalinium (Scheme I). In the series of the 6*H*-pyridocarbazole, olivacine derivatives hydrogenated on the pyridine ring were shown to retain some antitumor activity.<sup>26,27</sup> Therefore, a derivative of ditercalinium lacking the permanent charges located on N<sub>2</sub> was also prepared by reducing the pyridinic ring, in order to analyze the role of these charges in the biological and toxicological properties of ditercalinium. Efforts were made to prepare dihydropyridinic models, because they also might use NAD<sup>+</sup>-NADH as a specific delivery system toward the central nervous system.<sup>28</sup> Finally, we attempted to obtain analogues with a better bioavailability, either by improving the hydrophilicity of ditercalinium or by synthesizing analogues able to use amino acid transport systems.<sup>29</sup>

### Chemistry

The dimer without permanent positive charges on the chromophores (di-TH) was obtained by reduction with NaBH<sub>4</sub> of the N<sub>7</sub>-methylated analogue of ditercalinium as shown in Scheme I, part A.<sup>30</sup> Tentative efforts to obtain an analogue with a dihydropyridine ring in order to use NAD<sup>+</sup>-NADH oxidoreductive coupling as a delivery system failed. The action of sodium dithionite (Na<sub>2</sub>S<sub>2</sub>O<sub>3</sub>), reported to be a reducing agent for NAD<sup>+</sup> derivatives and other systems such as deazaflavins,<sup>31</sup> was tried but did not provide the expected ditercalinium analogue. Other attempts, using for instance the action of CF<sub>3</sub>COOH on the tetrahydropyridinic *N*-oxide derivative of the pyrido[4,3-*c*]carbazole ring (Polonovski reaction), did not yield the expected dihydropyridine analogue.

The two dimers connecting the convex face of the two 7*H*-pyridocarbazole rings, **di-6** and **di-7**, and a permanently positively charged analogue of this later quaternized on N<sub>2</sub>, **di-7b**, were synthesized as follows.

Dimer **di-6** was obtained by condensation of 2 equiv of 10-methoxy-7*H*-pyrido[4,3-*c*]carbazole-6-carboxylic acid (**2**) with 1 equiv of the 1,1'-bis(2-aminoethyl)-4,4'-bipiperidine (**4**) by classical peptide coupling method with *N*-cyclohexyl-*N'*-[2-(4-morpholinyl)ethyl]carbodiimide-methyl *p*-toluenesulfonate (EDC) and 1-hydroxybenzotriazole (HOBT) as coupling reagents. However 12 h of heating were required. 10-Methoxy-7*H*-pyrido[4,3-*c*]carbazole-6-carboxylic acid (**2**) has been prepared by hydrolysis of the 6-cyano precursor **1**<sup>19</sup> and the linking chain **4** obtained by action of NH<sub>4</sub>OH on the 1,1'-bis(2-chloroethyl)-4,4'-bipiperidine following the method of Kauffmann et al.<sup>32</sup> (Scheme I, part B).

- (16) Garbay-Jaureguiberry, C.; Laugãa, P.; Delepierre, M.; Laalami, S.; Muzard, G.; Le Pecq, J. B.; Roques, B. P. DNA bis-intercalators and new antitumor agents: Modulation of the antitumor activity by the linking chain rigidity in the series of ditercalinium. *Anticancer Drug Des.* 1987, 1, 323-335.
- (17) Léon, P.; Garbay-Jaureguiberry, C.; Le Pecq, J. B.; Roques, B. P. Relationship between the size and position of substituents on 7*H*-pyrido[4,3-*c*]carbazole monomers and dimers and their DNA binding and antitumor properties. *Anticancer Drug Des.* 1988, 3, 1-13.
- (18) Léon, P.; Garbay-Jaureguiberry, C.; Lambert, B.; Le Pecq, J. B.; Roques, B. P. *Asymmetrical* bisintercalators as potential antitumor agents. *J. Med. Chem.* 1988, 31, 1021-1026.
- (19) Léon, P.; Garbay-Jaureguiberry, C.; Barsi, M. C.; Le Pecq, J. B.; Roques, B. P. Modulation of the antitumor activity by methyl substitution in the series of 7*H*-pyridocarbazole monomers and dimers. *J. Med. Chem.* 1987, 30, 2074-2080.
- (20) Pothier, J.; Delepierre, M.; Barsi, M. C.; Garbay, C.; Igolen, J.; Le Bret, M.; Roques, B. P. Bis-intercalation of ditercalinium and flexible analogue in the octanucleotide d-(TpTpCpGpCpGpApA)<sub>2</sub>: A comparative study by NMR and molecular modeling. Proceedings of the 44th International Meeting of Physical Chemistry in Modelling of Molecular Structures and Properties; Rivail, J. L., Ed.; Elsevier: Amsterdam, 1990; pp 695-701.
- (21) Weiss, M. J.; Wong, J. R.; Ha, C. S.; Bleday, R.; Salem, R. R.; Staele, G. D.; Chen, L. B. Dequalinium, a topical antimicrobial agent, displays anticarcinoma activity based on selective mitochondrial accumulation. *Proc. Natl. Acad. Sci. U.S.A.* 1987, 84, 5444-5448.
- (22) Chen, L.; Weiss, M. J.; Davis, S.; Bleday, R. S.; Wong, J. R.; Song, J.; Terasaki, M.; Shepard, E. L.; Walker, E. S.; Steele, G. D., Jr. Mitochondria in living cells: Effects of growth factors and tumor promoters: Alterations in carcinoma cells, and targets for therapy. In *Cancer cells 3rd Growth Factors and Transformation*; Feramisco, J., Ozanne, B., Stiles, Ch., Eds., Cold Spring Harbor Laboratories: Cold Spring Harbor, NY, 1985; pp 433-443.
- (23) Fellous, R.; Coulaud, D.; El Abed, I.; Roques, B. P.; Le Pecq, J. B.; Delain, E.; Gouyette, A. In vivo and in vitro cytoplasmic accumulation of ditercalinium in rat hepatocytes. *Cancer Res.* 1988, 48, 6542-6549.
- (24) McGovren, J. P.; Clarke, G. L.; Pratt, A.; De Koning, T. F. Preliminary toxicity studies with the DNA binding antibiotic CC1065. *J. Antibiot.* 1984, 37, 63-70.
- (25) Wierenga, W.; Bhuyan, B. K.; Kelly, R. C.; Krueger, W. C.; Li, L. H.; McGovren, J. P.; Swenson, D. H.; Warpehoski, M. A. Antitumor activity and biochemistry of novel analogs of the antibiotic CC1065. *Adv. Enzyme Regul.* 1986, 25, 141-155.
- (26) Kutney, J. P.; Koda, M.; Lewis, N. G.; Monteiro, B.; Moskovicz, D.; Worth, B. Dihydropyridines in synthesis and biosynthesis. Synthesis of pyridocarbazole alkaloids: Olivacine and (±)-guatambuine. *Can. J. Chem.* 1982, 60, 2428-2432.
- (27) Mosher, C. W.; Crews, O. P.; Acton, E. M.; Goodman, L. Preparation and antitumor activity of olivacine and some new analogues. *J. Med. Chem.* 1986, 29, 237-240.
- (28) Bodor, N.; Farag, H. H. J. Improved delivery through biological membranes. A ribose chemical drug-delivery system and its use for brain-specific delivery of phenylethylamine. *J. Med. Chem.* 1983, 26, 313-318.
- (29) Thomas, W. A. Peptide derivatives as prodrugs. *Biochem. Soc. Trans.* 1986, 14, 383-387.
- (30) Husson, H. P.; Thal, C.; Potier, P.; Wenkert, E. The photocyclization of 1-(α-indolyl)-2-(β-pyridyl)acrylonitrile. *J. Org. Chem.* 1970, 35, 442-445.
- (31) Blankenhorn, G.; Moore, E. G. Sulfoxylate ion, the hydrid donor in dithionite-dependent reduction of NAD<sup>+</sup> analogues. *J. Am. Chem. Soc.* 1980, 102, 1092-1098.

Scheme II. (a) Synthesis of the 6-(Aminomethyl)-7H-pyridocarbazole Dimer 8 and (b) Synthesis of the 6-(Sugar-coupled)-7H-pyridocarbazole Dimer 11

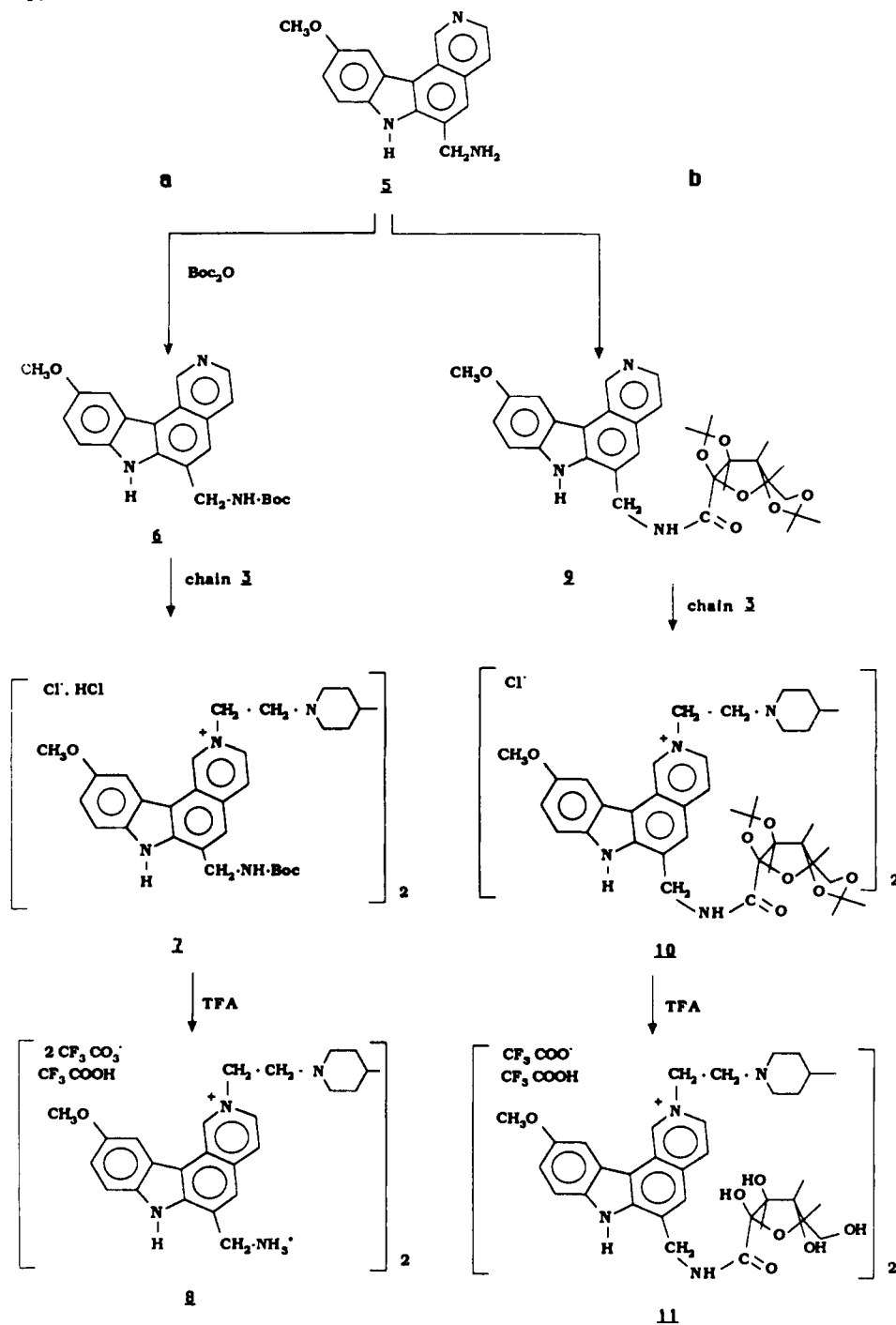

The di-7 dimer was synthesized by substituting the proton from nitrogen 7 of the pyridocarbazole rings with NaH and further condensing with 0.5 equiv of 1,1-bis(2-chloroethyl)-4,4'-bipiperidine following the method of Guthrie et al.<sup>33</sup> (Scheme I, part C). The permanently charged dimer di-7b was obtained by a similar method using 10-methoxy-2-methyl-7H-pyrido[4,3-c]carbazolium-2 iodide as starting material.

In order to modify the bioavailability of ditercalinium,

dimers bearing an aminomethyl or a carboxylic acid group, a sugar moiety, or an amino acid on the 7H-pyridocarbazole ring were synthesized as follows:

(1) Dimers bearing an aminomethyl group (compound 8) or a carboxylic acid (compound 20) on C<sub>6</sub> of 10-methoxy-7H-pyrido[4,3-c]carbazole (Schemes II and IV) were obtained by quaternarization with 1,1-bis(2-chloroethyl)-4,4'-bipiperidine (3) of the protected precursors 6 and 18, respectively providing 7 and 19 before final deprotection by TFA.

The protected 6-[(Boc-amino)methyl]-7H-pyrido[4,3-c]carbazole (6) was prepared by catalytic hydrogenation of compound 1 with Ni Raney as catalyst, providing 6-(aminomethyl)-7H-pyrido[4,3-c]carbazole (5), which had been submitted to the action of di-*tert*-butyl dicarbonate

(32) Kauffmann, T.; Nürnberg, R.; Wirthwein, R. *Liebigs Ann. Chem.* 1970, 731, 23-36.

(33) Guthrie, R. W.; Brossi, A.; Mennona, F. A.; Mullin, J. G.; Kierstead, R. W.; Grunberg, E. Ellipticine derivatives. *J. Med. Chem.* 1975, 18, 755.

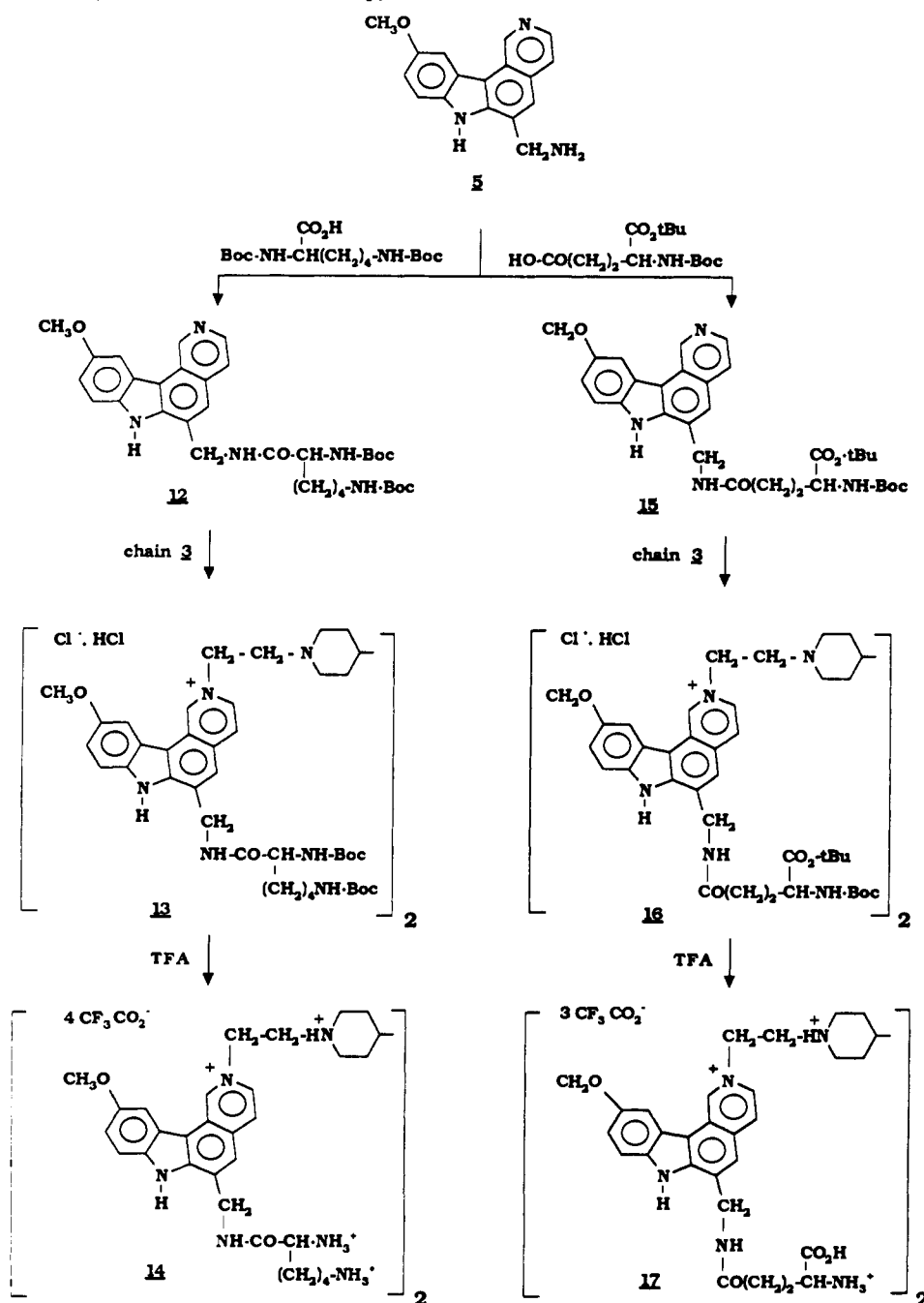
Scheme III. Synthesis of 6-(Amino acid substituted)-7*H*-pyridocarbazole Dimers

( $\text{Boc}_2\text{O}$ ) (Scheme II, part a).

The *tert*-butyl 7*H*-pyrido[4,3-*c*]carbazole-6-carboxylate (**18**) had been prepared by saponification of nitrile **1** followed by esterification of the formed acid **2** with dimethylformamide di-*tert*-butyl acetal (Scheme IV).

(2) In order to modify the 7*H*-pyrido[4,3-*c*]carbazole with a sugar moiety, tentative efforts were made to substitute the indolic proton  $\text{N}_7\text{H}$  with NaH and to condense it with a sugar halide, as reported by the group of Antonakis<sup>34</sup> for ellipticine derivatives. Although these attempts failed, coupling of the 6-(aminomethyl)-7*H*-pyridocarbazole (**5**) with the di-*O*-isopropylidene-protected gulonic acid (Scheme II, part b), followed by condensation with the 1,1'-bis(2-chloroethyl)-4,4'-bipiperidine chain (**3**) and deprotection of the sugar alcoholic functions with TFA,

provided a ditercalinium analogue bearing a sugar moiety on the 6-position of the 7*H*-pyridocarbazole ring.

(3) Dimers which might use amino acid transport systems were prepared by derivatization of either the 6-(aminomethyl) or the 6-carboxylic acid group of the 7*H*-pyridocarbazole using usual peptide coupling conditions: dicyclohexylcarbodiimide (DCC), and 1-hydroxybenzotriazole (HOBT) with C- or N-terminal protected amino acids (Schemes III and IV). Then, the 7*H*-pyridocarbazole rings coupled to protected amino acids were linked with the dimerization chain **3**. The deprotection of the amino acids moiety (TFA action) of the protected dimers was carried out in the last step. Dimers coupled to amino acid with either free carboxylic or amino group or both were obtained by this way.

### Results and Discussion

The results reported in Table I show that the analogue of ditercalinium obtained by reducing the pyridine rings,

(34) Bessodes, M.; Dat-Xuong, N.; Antonakis, K. C. R. Ellipticine nucleosides. *C. R. Acad. Sci. Ser. C* 1976, 282, 1001-1002.

Scheme IV. Synthesis of the 7H-Pyridocarbazole-6-carboxylic Acid Dimer 20 and of Its Analogue Coupled with a Glycine Residue 23

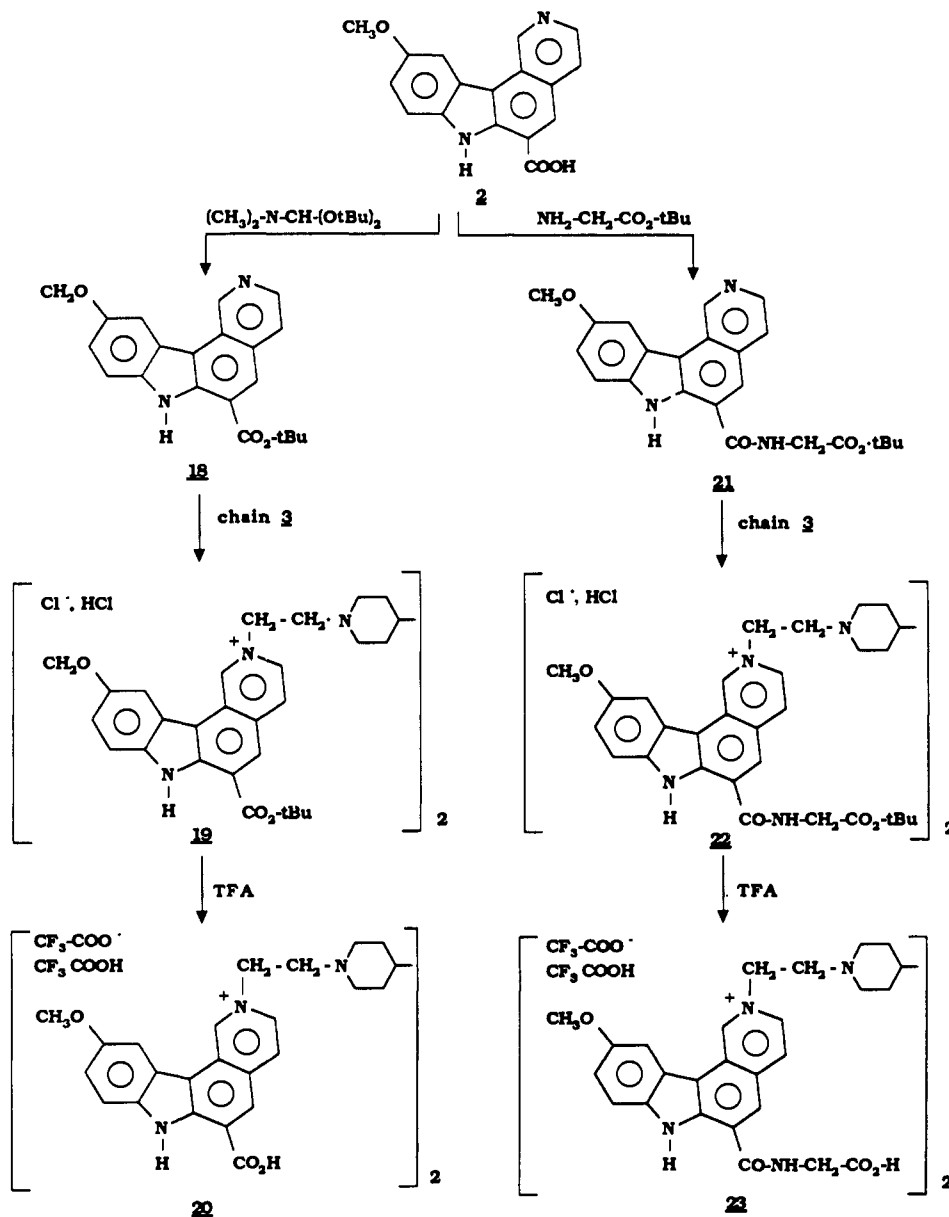

di-TH, retains its aptitude to bisintercalate ( $\Delta L = 4.46$ ) into DNA with a high affinity ( $4 \times 10^7 \text{ M}^{-1}$ ) although the intercalated moieties do not remain entirely planar. This is not surprising as daunomycin, a tetracycline with one nonaromatic ring, was shown to intercalate into DNA<sup>35,36</sup> and a series of dimeric antitumor daunomycins was reported to bisintercalate into DNA.<sup>37</sup> However, X-ray analyses have shown that the daunomycin aglycon chromophore intercalates through the minor groove at right angles to the long dimension of the DNA base pairs with

Table I. DNA Interactions and Antitumor Properties of New Dimers in the Ditercalinium Series<sup>a</sup>

	$V_r$	$\Delta L$	$K_a$	cellular toxicity		antitumor activity		
				ED <sub>50</sub>	EC <sub>37</sub>	MTD	OD	% T/C
di-TH	15.3	4.46	$4 \times 10^7$	0.66	0.60	10	10	NS
di-6	12.5	3.79	$2 \times 10^8$	11	30	10	10	NS
di-7	12.5	1.62	$10^7$	0.6	ND	10	10	NS
di-7b	11.9	3.00	$>10^9$	0.90	ND	5	5	134
ditercalinium	12.6	3.6	$10^7$	0.19	0.14	10	10	182

<sup>a</sup>  $K_a$  ( $\text{M}^{-1}$ ): affinity constant for DNA.  $\Delta L$ : helix extension measured by sonicated DNA viscometric lengthening ( $6 > \Delta L > 3$  is characteristic of a bisintercalating drug). Cellular toxicity: ED<sub>50</sub> is the dose which inhibits cellular growth by a factor 50% (in  $\mu\text{M}$ ). Cloning efficiency: EC<sub>37</sub> is the dose which inhibits the cellular cloning by a factor 37% (in  $\mu\text{M}$ ). % T/C: mean % survival of treated/control animals. Antitumor activity: MTD is the maximal tolerated dose (mg/kg). OD: optimal dose (mg/kg). ND: not determined. NS: values not significant.  $V_r$ : retention volume on C<sub>8</sub>  $\mu$ Bondapak HPLC column (see the Experimental Section).

- (35) Quigley, G. J.; Wang, A. H. J.; Uguetto, G.; Van der Marel, G.; Van Boom, J. H.; Rich, A. Molecular structure of an anticancer drug-DNA complex: Daunomycin plus d(CpGpTpApCpG). *Proc. Natl. Acad. Sci. U.S.A.* 1980, 77, 7204-7208.
- (36) Phillips, D.; Roberts, G. C. K. Proton magnetic resonance study of the self-complementary hexanucleotide d(pTpA)<sub>3</sub> and its interaction with daunomycin. *Biochemistry* 1980, 19, 4795-4801.
- (37) Brownlee, R. T. C.; Cacioli, P.; Chandler, C. J.; Philips, D. R.; Scourides, P. A.; Reiss, J. A. The synthesis and characterization of a series of bis-intercalating bis-anthracyclines. *Chem. Commun.* 1986, 659-660.

the cyclohexyl ring located in the minor groove outside the intercalation site.<sup>35</sup> According to these results, the loss of antitumor activity of di-TH could be related to its DNA complex, whose structure would be different from that of

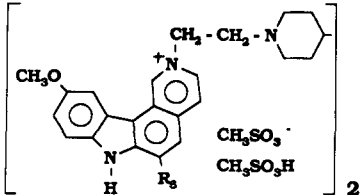
**Table II.** DNA Binding and Antitumor Properties of 7*H*-Pyridocarbazole Dimers Substituted on C<sub>6</sub><sup>a</sup>

R <sub>6</sub>	V <sub>r</sub>	K <sub>a</sub>	ΔL	cellular toxicity on L1210		antitumor activity on L1210		
				ED <sub>50</sub>	EC <sub>37</sub>	MTD	OD	% T/C
H	12.6	1 × 10 <sup>7</sup>	3.6	0.19	0.024	10	10	182
CH <sub>3</sub>	ND	5 × 10 <sup>8</sup>	6.16	0.37	0.10	11	7	172
CH <sub>2</sub> NH <sub>3</sub> <sup>+</sup>	8.25	2 × 10 <sup>7</sup>	4.6	0.057	0.066	20	10	NS
CH <sub>2</sub> NH-L-Lys(NH <sub>3</sub> <sup>+</sup> )	8.4	2 × 10 <sup>8</sup>	5.1	0.32	0.05	20		NS
CH <sub>2</sub> NH-L-Glu	8.8	NM	2.81	0.46	>0.58			NM
COOH	12.5	2.5 × 10 <sup>5</sup>	2.18	>0.8	>0.8			NM
CO-Gly(COOH)	12.1	2.8 × 10 <sup>4</sup>	0	>0.7	>0.7			NM
CO-sugar	ND	3 × 10 <sup>6</sup>	2.18	2.15	ND			ND

<sup>a</sup>ΔL: helix extension slope. K<sub>a</sub> (M<sup>-1</sup>): affinity constant for DNA. Cellular toxicity: ED<sub>50</sub> is the growing inhibition (in μM). EC<sub>37</sub>: Cloning efficiency (in μM). Antitumor activity: MTD is the maximal tolerated dose (mg/kg). OD: optimal dose (mg/kg) to increase the life time of treated mice. % T/C: treated survival/control. V<sub>r</sub>: retention volume measured by HPLC on a C<sub>8</sub> μBondapak column (see the Experimental Section). ND: not determined. NM: not measurable due to weak solubility. NS: not significant.

ditercalinium. Alternatively the absence of permanent charges might prevent the accumulation of di-TH in the mitochondria.

The new dimers **di-6**, **di-7**, and **di-7b** appear quite different from the numerous dimeric analogues of ditercalinium already prepared and studied in our laboratory, because their connecting chain links the convex faces of the pyridocarbazole rings instead of the concave ones in ditercalinium. In **di-6**, a longer chain than the usual diethylbipiperidine chain of ditercalinium was used to compensate the rigidity of the amide bond which reduces the length of the spacer. Dimer **di-6** bisintercalated with a high DNA affinity but proved to be completely devoid of antitumor activity and without any toxic effects on cellular growth. These results suggest that either the intercalating complex of **di-6** with DNA or its cellular localization is different from that of ditercalinium.

In the **di-7** dimer, the distance between the two 7*H*-pyridocarbazole rings is similar to that estimated in ditercalinium (~12 Å). However, as shown in Table I, **di-7** behaves as a DNA monointercalator and its lack of antitumor properties is therefore not surprising. More striking is the behavior of **di-7b**. Although it only differs from **di-7** by the quaternization of N<sub>2</sub> of the 7*H*-pyridocarbazole rings, it has a very high DNA affinity. Its DNA intercalating aptitude follows a rather complicated model, as shown by its DNA viscometric lengthening slope, which is rather weak for low concentrations and very steep for higher ones, suggesting a bisintercalation into DNA through a cooperative mode of interaction. The more interesting fact is that **di-7b** recovers a significant antitumor activity (Table I). It is probable, from a comparison of their cellular toxicity, that **di-7b** and ditercalinium do not develop their antitumor activity in a similar way. However it is very interesting to observe that when permanent positive charges are introduced on N<sub>2</sub> of **di-7**, the antitumor properties are recovered. This provides support for the essential role played by the positive charges in the DNA interaction and antitumor properties of the two 7*H*-pyridocarbazole dimer series. By analogy with ditercalinium, whose antitumor properties have been recently related to its ability to cause the degradation of mitochondrial DNA, it seems likely that **di-7b**, with its two permanent charges, is also preferentially concentrated in

mitochondria. Thus, the comparison of the complexes formed between **di-7b** or ditercalinium and oligonucleotides will provide information about a possible analogy in the molecular mechanism of action of the two dimers.

In order to obtain derivatives devoid of hepatotoxicity<sup>23</sup> and taking into account that 6-alkylated dimers are biologically active,<sup>19</sup> dimers with an aminomethyl or a carboxylic group on the 6-position of the pyridocarbazole ring were prepared. Dimer **20**, bearing a carboxylic group, did not appear to be more hydrophilic than ditercalinium, as observed from their similar HPLC profiles on a C<sub>8</sub> column, and it was found to be totally inactive on L 1210 culture cells. Dimer **20** is characterized by a low DNA affinity in relation to its monointercalating properties, probably due to the presence of a negatively charged group on the heterocyclic ring.

In contrast, dimer **8**, bearing an aminomethyl group on C<sub>6</sub>, appears to be significantly more hydrophilic than ditercalinium. It behaves as a DNA bisintercalator and is characterized by a high DNA affinity and a high cytotoxicity against L 1210 cells in culture, lying in almost the same range as ditercalinium (Table I). However, this derivative did not possess, as expected, significant antitumor properties *in vivo*, suggesting that it could be trapped somewhere before reaching the mitochondria.

Dimers able to use amino acid transport systems were expected to be less toxic. Indeed, amino acids or short peptides appear to be appropriate moieties for use in prodrugs because they are generally highly water soluble, readily cleaved by peptidases to give the active compound, often lend themselves to active transport across cell membranes, and the amino acid products of peptidase-induced hydrolysis have no apparent toxicological effects. Analogue **23** coupled with a glycyl residue on the 6-carboxylic group also has a free carboxylic group like dimer **20** and is also monointercalating with a low DNA affinity. This might be explained by repulsive interactions between the DNA phosphate groups and dimer carboxylates at physiological pH. The loss of activity of the dimers **20** and **23** might therefore be related, at least partly, to their monointercalating properties. Dimer **14** (Scheme III) bearing a lysine coupled to the 6-(aminomethyl) residue has two positively charged amino groups and retains a high

DNA affinity and a good efficacy against L 1210 cellular growth. The DNA bisintercalation of 14 is rather surprising since, in addition to the rigid diethylbipiperidine linker, the dimer possesses on C<sub>6</sub> a long and hindered chain which could project out of the DNA minor groove, if it is accepted that dimer 14 bisintercalates into DNA similarly to ditercalinium. This is an interesting result, suggesting that large time-dependent changes of the DNA structure (opening, tilting, ...) must occur to allow the intercalation of the dimer. Obviously this leads to a high DNA affinity constant, probably reflecting a long off-rate constant. Nevertheless, no significant activity was obtained in vivo, suggesting that the prodrug 14 is too rapidly metabolized or that it is also trapped before reaching its target. Dimer 17, coupled to a glutamic residue through its carboxylic side chain, behaves, as do acids 20 and 23, as DNA monointercalator and has no activity against L 1210 cellular growth. Dimer 11, bearing a carbohydrate moiety on the C<sub>6</sub> of the pyridocarbazoles, was significantly more hydrophilic than ditercalinium, but it appears to monointercalate into DNA, accounting probably for its lack of antitumor properties as well as cellular toxicity on L 1210 cells.

In conclusion, this work clearly demonstrates the essential role played by the permanent charges localized on N<sub>2</sub>-positions of the two 7H-pyrido[4,3-c]carbazole rings for antitumor activity in agreement with the hypothesis that mitochondrial DNA appears to be the major target of these dimers.<sup>9</sup> However, the presence of charges is not sufficient since in the ditercalinium series, dimers with one or no methylene group in the linking chain between the two piperidine rings are active while dimers with two and three methylene groups lose their activity, although all the molecules bear identically located positive charges. These differences in activity have been related to changes in DNA-complex geometry<sup>12</sup> of the various dimers. Thus, both the cellular localization and the type of DNA interaction appear to be essential for antitumor activity in the ditercalinium series. This makes it difficult to evaluate the chemical modifications capable of retaining antitumor activity while changing the hydrophobic/hydrophilic character of the molecules. We have shown that suppression or addition of charges is not advantageous, even when the dimers behave as DNA bisintercalators. Deceptively, the addition of hydrophilic substituents on the 7H-pyridocarbazole rings did not retain the antitumor properties of ditercalinium. Taking these results into account, two approaches now seem realistic for designing dimers with antitumor activity and decreased toxicity: (1) to link the 7H-pyridocarbazole rings with a more hydrophilic bipiperidine-derived chain and (2) to prepare dimers with smaller and then less hydrophobic chromophores in place of 7H-pyrido[4,3-c]carbazoles. These approaches are now being investigated in the laboratory.

## Experimental Section

Melting points were determined on a Kofler apparatus and were not corrected. The structures of all products were established by <sup>1</sup>H NMR spectra obtained on a Bruker 270-MHz spectrometer. Mass spectra were obtained on a RIBERMAG R.10.10.C spectrometer. Where analyses are indicated only by the symbols of elements, analytical results obtained for those elements were within ±0.4% of the theoretical values.

UV spectra and molar extinction coefficients were recorded on a Beckman Acta III spectrophotometer. Fluorometric measurements were conducted with a photon-counting SLM-800 (Urbana, IL) or with a Kontron SFM 23/B (Zurich, Switzerland) spectrofluorometer.

Purifications were achieved by silica gel preparative layer. Chromatographic purity and hydrophobicity were checked by HPLC on a μBondapak C<sub>8</sub> column (Waters Associates) with

CH<sub>3</sub>CN-TFA 1% in H<sub>2</sub>O, gradient from 20/80 to 100/00, as eluant.

**Synthesis. 10-Methoxy-7H-pyrido[4,3-c]carbazole-6-carboxylic Acid (2).** 6-Cyano-10-methoxy-7H-pyrido[4,3-c]carbazole (1;<sup>18</sup> 500 mg, 1.83 mmol) dissolved, at 60 °C, in 30 mL of an ethanolic KOH (2 M) solution was stirred for 10 h, at 80 °C. The reaction mixture was then allowed to come to room temperature. H<sub>2</sub>O (75 mL) and 10 N HCl (12 mL, final pH 6) were added, and an orange solid precipitated which was washed with H<sub>2</sub>O and dried in vacuo. After recrystallization in acetic acid, compound 2 was obtained (449 mg, 84%). Mp: >260 °C. CI-MS: MH<sup>+</sup> = *m/e* 293. Anal. (C<sub>17</sub>H<sub>13</sub>N<sub>2</sub>O<sub>3</sub>): C, H, N.

**1,1'-Bis(2-aminoethyl)-4,4'-bipiperidine (4).** To a mixture of aqueous 10 N NH<sub>4</sub>OH (54 mL) and MeOH (27 mL) was added slowly (30 min) a solution of 1,1'-bis(2-chloroethyl)-4,4'-bipiperidinium hydrochloride (3; 2 g, 5.46 mmol) in H<sub>2</sub>O (16 mL). The reaction mixture was stirred for 2 h at 50 °C and cooled to 20 °C. Aqueous 1 N NaOH (22 mL) was added, and the solvents were evaporated in vacuo. The resulting white solid was diluted in EtOH (200 mL), and mineral crystals were filtered. Compound 4 crystallized through concentration of the filtrate (1.2 g, 87%). Mp: >260 °C.

**Dimer di-6.** 10-Methoxy-7H-pyrido[4,3-c]carbazole-6-carboxylic acid (2; 600 mg, 2.05 mmol) was dissolved, at 80 °C in anhydrous DMF (100 mL). To this solution were added, successively, 1,1'-(2-aminoethyl)-4,4'-bipiperidine (4; 280 mg, 1.1 mmol) in anhydrous CHCl<sub>3</sub> (10 mL), 1-hydroxybenzotriazole (HOBT; 300 mg, 2.05 mmol) in anhydrous THF (15 mL), and *N*-cyclohexyl-*N'*-[2-(4-morpholinyl)ethyl]carbodiimide-methyl *p*-toluenesulfonate (EDC; 800 mg, 2.05 mmol) in anhydrous CHCl<sub>3</sub> (30 mL).

The reaction mixture was stirred at 80 °C for 12 h, the solvent evaporated in vacuo, and the resulting orange residue chromatographed, first over a Sephadex LH20 resin column (CH<sub>2</sub>Cl<sub>2</sub>-MeOH 1/1) and then over a silica gel column (CH<sub>2</sub>Cl<sub>2</sub>-MeOH-NH<sub>4</sub>OH 7/1/0.5) to provide the dimer (118 mg, 13%). Mp: >260 °C. Formula: C<sub>48</sub>H<sub>48</sub>N<sub>8</sub>O<sub>4</sub>. HPLC: V<sub>r</sub> = 12.5 mL. FAB-MS: MH<sup>+</sup> = *m/e* 802. <sup>1</sup>H NMR ((C<sup>2</sup>H<sub>5</sub>)<sub>2</sub>SO) (δ ppm from HMDS): 11.82 (s, 1 H, H<sub>7</sub>), 10.18 (s, 1 H, H<sub>1</sub>), 8.91 (t, 1 H, NH), 8.57 (d, 1 H, H<sub>3</sub>), 8.29 (s, 1 H, H<sub>5</sub>), 8.04 (s, 1 H, H<sub>11</sub>), 7.93 (d, 1 H, H<sub>9</sub>), 7.76 (d, 1 H, H<sub>9</sub>), 7.07 (d, 1 H, H<sub>9</sub>), 3.91 (s, 3 H, OCH<sub>3</sub>), 3.49 (m, 2 H, CH<sub>2</sub> (a)), 3.31 (m, 2 H, CH<sub>2</sub>), 3.00 (m, 2 H, CH<sub>2</sub>), 2.58 (m, 2 H, CH<sub>2</sub>), 1.60 (m, 2 H, CH<sub>2</sub> (d<sub>eq</sub>)), 1.15 (m, 3 H, CH<sub>2</sub> (d<sub>ax</sub>) + CH (e)).

**Dimer di-7.** Sodium hydride (100 mg, 3 × 1 mmol) was added under nitrogen to a stirred solution of 248 mg (1 mmol) of the 10-methoxy-7H-pyrido[4,3-c]carbazole in 50 mL of anhydrous DMF. The solution was stirred at room temperature for 1 h and 145 mg (0.5 mmol) of the linking chain 3 (desalified with an aqueous solution of NaOH) in anhydrous DMF was added over 30 min. The mixture was stirred at room temperature for 3 days and the resulting precipitate was collected by filtration and thoroughly washed with H<sub>2</sub>O to provide unprotonated di-7 dimer (270 mg, 75%).

To a suspension of 1 equiv of the preceding compound (72 mg, 0.1 mmol) in 15 mL of H<sub>2</sub>O was added 4 equiv of methanesulfonic acid diluted in 1 mL of H<sub>2</sub>O. The resulting yellow solution was lyophilized to afford di-7 (105 mg, 95%). Mp: 190 °C. Formula: C<sub>48</sub>H<sub>48</sub>N<sub>8</sub>O<sub>2</sub>·4CH<sub>3</sub>SO<sub>3</sub>H. HPLC: V<sub>r</sub> = 11.88 mL. FAB-MS: MH<sup>+</sup> = *m/e* 717.75. <sup>1</sup>H NMR ((C<sup>2</sup>H<sub>5</sub>)<sub>2</sub>SO) (δ ppm from HMDS): 10.45 (s, 1 H, H<sub>1</sub>), 9.67 (s, 1 H, NH<sup>+</sup>), 8.67 (m, 3 H, H<sub>3</sub> + H<sub>4</sub> + H<sub>6</sub>), 8.38 (d, 1 H, H<sub>5</sub>), 8.02 (s, 1 H, H<sub>11</sub>), 7.96 (d, 1 H, H<sub>9</sub>), 7.23 (d, 1 H, H<sub>9</sub>), 5.03 (m, 2 H, CH<sub>2</sub> (b)), 3.96 (s, 3 H, OCH<sub>3</sub>), 3.68 (m, 2 H, CH<sub>2</sub> (eq)), 3.47 (m, 2 H, CH<sub>2</sub> (c<sub>eq</sub>)), 3.03 (m, 2 H, CH<sub>2</sub> (c<sub>ax</sub>)), 2.33 (m, 6 H, CH<sub>3</sub>SO<sub>3</sub><sup>-</sup>), 1.95 (m, 2 H, CH<sub>2</sub> (d<sub>eq</sub>)), 1.47 (m, 3 H, CH<sub>2</sub> (d<sub>ax</sub>) + CH (e)).

**Dimer di-7b.** A 46-mg portion of NaH (2.5 × 0.385 mmol) was added, at room temperature, to 150 mg (0.385 mmol) of 2-methyl-10-methoxy-7H-pyrido[4,3-c]carbazolium-2 iodide dissolved in 25 mL of DMF at room temperature for 20 min. A 62-mg portion (0.5 × 0.385 mmol) of the linking chain 3 (desalified with an aqueous solution of NaOH) in anhydrous DMF was added over 30 min. The mixture was stirred at room temperature for 3 days and the resulting precipitate collected. After washing, 148 mg (70%) of the dimer was obtained. The counterion of the dimer thus obtained was exchanged from iodide to methanesulfonate



by reaction with  $\text{CH}_3\text{SO}_3\text{Ag}$  (4 equiv) in  $\text{EtOH-H}_2\text{O}$  (20/80) under reflux for 1 h. After cooling, the solution was centrifugated (five times for 20 min at 4500 rpm), and the residues were discarded. The solution was lyophilized to provide **di-7b** (90%). Mp: 220 °C. HPLC:  $V_r = 11.95$  mL.

**Dimer di-TH.** To a suspension of *N*-methyliditercalinium (65 mg, 0.061 mmol) in  $\text{CH}_3\text{OH-H}_2\text{O}$  (10 mL, 9/1) was added, dropwise, at room temperature, 11 equiv of  $\text{NaBH}_4$  (25 mg). The reaction mixture was stirred at room temperature for 90 min and then concentrated in vacuo. The white solid obtained was washed with  $\text{H}_2\text{O}$  and dried in vacuo (45 mg, 98%). To a solution of the preceding compound in MeOH (3 mL) was added an aqueous solution of  $\text{CH}_3\text{SO}_3\text{H}$  (1.5 M, 0.08 mL,  $2 \times 0.064$  mmol). After evaporation of the MeOH, the resulting residue was solubilized in  $\text{H}_2\text{O}$  (50 mL) and the solution was centrifugated, filtered, and then lyophilized, yielding **di-TH** (45 mg, 80%). Mp: 212 °C. Formula:  $\text{C}_{48}\text{H}_{60}\text{N}_6\text{O}_2 \cdot 2\text{CH}_3\text{SO}_3\text{H}$ . HPLC:  $V_r = 15.33$  mL. FAB-MS:  $\text{MH}^+ = m/e$  953.  $^1\text{H NMR}$  ( $(\text{C}^2\text{H}_5)_2\text{SO}$ ) ( $\delta$  ppm from HMDS): 7.48 (s, 1 H,  $\text{H}_{11}$ ), 7.46 (d, 1 H,  $\text{H}_6$ ), 7.36 (d, 1 H,  $\text{H}_6$ ), 7.18 (d, 1 H,  $\text{H}_5$ ), 7.09 (d, 1 H,  $\text{H}_9$ ), 4.30 (s, 2 H,  $\text{CH}_2$  (1)), 3.80 (s, 3 H,  $\text{OCH}_3$ ), 3.68 (s, 3 H,  $\text{NCH}_3$ ), 3.49 (d, 2 H,  $\text{CH}_2$  (b)), 3.28 (s, 2 H,  $\text{CH}_2$  (3)), 3.08–2.78 (m, 8 H,  $\text{CH}_2$  ( $c_{ax}$ ) +  $\text{CH}_2$  (4) +  $\text{CH}_2$  ( $c_{eq}$ ),  $\text{CH}_2$  ( $c_{ax}$ )), 2.24 (s, 6 H,  $2\text{CH}_3\text{SO}_3^-$ ), 1.76 (d, 2 H,  $\text{CH}_2$  ( $d_{eq}$ )), 1.33 (m, 3 H,  $\text{CH}_2$  ( $d_{ax}$ ) + CH (e)).

***N*-(*tert*-Butoxycarbonyl)-6-(aminomethyl)-10-methoxy-7H-pyrido[4,3-*c*]carbazole (6).** To a solution of 6-(aminomethyl)-10-methoxy-7H-pyridocarbazole (5; 305 mg) in 5 mL of anhydrous DMF was added at 0 °C 1.1 equiv of di-*tert*-butyl dicarbonate in 1 mL of DMF. The reaction mixture was stirred for 1 h at 0 °C and 3 h at room temperature. After evaporation of the solvent, the oily residue was basified with 10%  $\text{NaHCO}_3$ . Compound **6** was extracted from  $\text{CH}_2\text{Cl}_2$  to yield, after evaporation of the solvent, 195 mg (80%) of an orange solid. Mp: 180 °C. CI-MS:  $\text{MH}^+ = m/e$  378. Anal. ( $\text{C}_{22}\text{H}_{23}\text{N}_3\text{O}_3$ ): C, H, N.

**7H-Pyridocarbazoles Linked to Protected Amino Acids: 12 and 15.** To a solution of 6-(aminomethyl)-10-methoxy-7H-pyrido[4,3-*c*]carbazole (5; 1 mmol) in 5 mL of anhydrous DMF were added the appropriate protected amino acid (1 equiv) in 3 mL of anhydrous DMF, HOBT (153 mg, 1 mmol), and EDC (195 mg) also in small quantities of DMF. The mixture was stirred for 1 h at 0 °C and 3 days at room temperature. The solvent was evaporated in vacuo. The yellow precipitate was triturated with aqueous 2% HCl until the obtention of a pulverulent product. After centrifugation, the supernatant was successively washed with water, 10%  $\text{NaHCO}_3$ , water, and diethyl ether. The resulting precipitate was dried to give the desired pyridocarbazole. From Boc-Lys(Boc) was obtained **12** (yield 50%). Mp: 195 °C. Anal. ( $\text{C}_{33}\text{H}_{43}\text{N}_5\text{O}_6$ ): C, H, N. From Boc-Glu-OtBu was obtained **15** (yield 50%). Mp: 200 °C. MS:  $\text{MH}^+ = m/e$  563. Anal. ( $\text{C}_{31}\text{H}_{38}\text{N}_4\text{O}_6$ ): C, H, N.

**Dimerization of 7H-Pyridocarbazoles 6, 12, and 15 with 1,1'-Bis(2-chloroethyl)-4,4'-bipiperidine (7, 13, and 16).** The linking chain **3** (0.6 equiv) dissolved in water was added dropwise over 30 min to a stirred solution of the corresponding pyridocarbazole (1 equiv) in DMF. The mixture was stirred for 48 h at 80 °C and then cooled to room temperature. In the case of **6**, the resulting precipitate was collected by filtration, washed with ether, and thoroughly dried in vacuo. **6** yielded **7** (65%). Mp: >260 °C. Anal. ( $\text{C}_{58}\text{H}_{74}\text{N}_8\text{O}_6\text{Cl}_4$ ): C, H, N.

In the case of **12** and **15**, the solvent was evaporated in vacuo to dryness, and the products were chromatographed over a Sephadex LH20 resin column ( $\text{CH}_2\text{Cl}_2$ -MeOH 1/1). **12** yielded **13** (44%). Mp: >260 °C. Anal. ( $\text{C}_{80}\text{H}_{114}\text{N}_{12}\text{O}_{12}\text{Cl}_4$ ): C, H, N.

**15** yielded **16** (25%). Mp: >260 °C. Anal. ( $\text{C}_{76}\text{H}_{104}\text{N}_{10}\text{O}_{12}\text{Cl}_4$ ): C, H, N.

**Deprotection of Dimers 7, 13, and 16 (8, 14, and 17).** A solution of the appropriate dimer **7**, **13**, or **16** (0.1 mmol) in TFA (150  $\mu\text{L}$ ) and  $\text{CH}_2\text{Cl}_2$  (150  $\mu\text{L}$ ) was stirred for 1 h at 0 °C and for 1 h at room temperature. After evaporation in vacuo, the residue was precipitated with dry ethyl ether.

**7** yielded **8** (80%). Mp: >260 °C. Formula:  $\text{C}_{46}\text{H}_{56}\text{N}_8\text{O}_2 \cdot 2\text{C}_2\text{F}_3\text{CO}_2\text{H}$ . FAB-MS:  $\text{M}^+ = m/e$  776,  $\text{M}^+ + \text{CF}_3\text{COOH} = m/e$  890. HPLC:  $V_r = 8.25$  mL.  $^1\text{H NMR}$  ( $(\text{C}^2\text{H}_5)_2\text{SO}$  + TFA) ( $\delta$  ppm from HMDS): 12.93 (s, 1 H,  $\text{H}_7$ ), 11.32 (m, 1 H, ( $\text{N}^+\text{H}$ )), 10.44 (s, 1 H,  $\text{H}_1$ ), 8.86 (m, 4 H,  $\text{N}^+\text{H}_3 + \text{H}_3$ ), 8.69 (d, 1 H,  $\text{H}_4$ ), 8.35 (s, 1 H,  $\text{H}_{11}$ ), 8.27 (s, 1 H,  $\text{H}_5$ ), 7.77 (d, 1 H,  $\text{H}_6$ ), 7.33 (d, 1

H,  $\text{H}_9$ ), 5.47 (m, 2 H,  $\text{CH}_2$  (a)), 4.71 (m, 2 H,  $\text{CH}_2\text{N}^+\text{H}_3$ ), 4.00 (s, 3 H,  $\text{OCH}_3$ ), 3.89 (m, 2 H,  $\text{CH}_2$  (b)), 3.68 (m, 2 H,  $\text{CH}_2$  ( $c_{eq}$ )), 3.00 (m, 2 H,  $\text{CH}_2$  ( $c_{ax}$ )), 1.91 (m, 2 H,  $\text{CH}_2$  ( $d_{eq}$ )), 1.60 (m, 2 H,  $\text{CH}_2$  ( $d_{ax}$ )), 1.38 (m, 1 H, CH (e)).

**13** yielded **14** (70%). Mp: 254 °C. Formula:  $\text{C}_{60}\text{H}_{80}\text{N}_{12}\text{O}_4 \cdot 8\text{CF}_3\text{CO}_2\text{H}$ . FAB-MS:  $\text{M}^+ = m/e$  1032,  $\text{M}^+ + \text{CF}_3\text{COOH} = m/e$  1140. HPLC:  $V_r = 8.38$  mL.  $^1\text{H NMR}$  ( $(\text{C}^2\text{H}_5)_2\text{SO}$  + TFA) ( $\delta$  ppm from HMDS): 12.74 (s, 1 H,  $\text{H}_7$ ), 10.33 (s, 1 H,  $\text{H}_1$ ), 9.55 (m, 1 H, ( $\text{N}^+\text{H}$ )), 8.85 (d, 1 H,  $\text{H}_3$ ), 8.69 (d, 1 H,  $\text{H}_4$ ), 8.38 (m, 3 H,  $\text{N}^+\text{H}_3$ ), 8.31 (s, 1 H,  $\text{H}_{11}$ ), 8.11 (s, 1 H,  $\text{H}_5$ ), 7.85 (m, 3 H,  $\text{N}^+\text{H}_3$ ), 7.80 (d, 1 H,  $\text{H}_6$ ), 7.25 (d, 1 H,  $\text{H}_9$ ), 5.41 (m, 2 H,  $\text{CH}_2$  (a)), 5.08 (d, 1 H,  $\text{CH}_2\text{NH}$ ), 4.91 (d, 1 H,  $\text{CH}_2\text{NH}$ ), 3.98 (s, 3 H,  $\text{OCH}_3$ ), 3.95 (m, 1 H,  $\text{H}_a$ ), 3.91 (m, 2 H,  $\text{CH}_2$ (b)), 3.70 (m, 2 H,  $\text{CH}_2$  ( $c_{eq}$ )), 3.04 (m, 2 H,  $\text{CH}_2$  ( $c_{ax}$ )), 2.74 (m, 2 H,  $\text{CH}_2$  (e)), 1.99–1.30 (m, 11 H,  $\text{CH}_2$  ( $d_{eq}$ ) +  $\text{CH}_2$  ( $d_{ax}$ ) +  $\text{CH}_2$  ( $\beta$ ) +  $\text{CH}_2$  ( $\gamma$ ) +  $\text{CH}_2$  ( $\delta$ ) + CH (e)). **16** yielded **17** (90%). Mp: >260 °C. Formula:  $\text{C}_{58}\text{H}_{68}\text{N}_{10}\text{O}_8 \cdot 6\text{CF}_3\text{CO}_2\text{H}$ . FAB-MS:  $\text{M}^+ = m/e$  1033. HPLC:  $V_{mr} = 8.85$  mL.  $^1\text{H NMR}$  ( $(\text{C}^2\text{H}_5)_2\text{SO}$  + TFA) ( $\delta$  ppm from HMDS): 12.52 (s, 1 H,  $\text{H}_7$ ), 10.29 (s, 1 H,  $\text{H}_1$ ), 8.88 (m, 3 H,  $\text{N}^+\text{H}_3$ ), 8.75 (d, 1 H,  $\text{H}_3$ ), 8.62 (d, 1 H,  $\text{H}_4$ ), 8.25 (m, 2 H,  $\text{H}_{11}$  + NH), 7.98 (s, 1 H,  $\text{H}_5$ ), 7.71 (d, 1 H,  $\text{H}_6$ ), 7.29 (d, 1 H,  $\text{H}_9$ ), 5.37 (m, 2 H,  $\text{CH}_2$  (a)), 4.87 (m, 2 H,  $\text{CH}_2\text{NH}$ ), 3.97 (s, 3 H,  $\text{OCH}_3$ ), 3.91 (m, 1 H,  $\text{H}_a$ ), 3.86 (m, 2 H,  $\text{CH}_2$  (b)), 3.68 (m, 2 H,  $\text{CH}_2$  ( $c_{eq}$ )), 2.99 (m, 2 H,  $\text{CH}_2$  ( $c_{ax}$ )), 2.10–1.85 (m, 6 H,  $\text{CH}_2$  ( $d_{eq}$ ) +  $\text{CH}_2$  ( $\alpha$ ) +  $\text{CH}_2$  ( $\beta$ )), 1.44 (m, 3 H,  $\text{CH}_2$  ( $d_{ax}$ ) + CH (e)).

***N*-(10-Methoxy-7H-pyrido[4,3-*c*]carbazol-6-yl)-2,3,4,6-di-*O*-isopropylidene- $\alpha$ -L-xylo-2-hexulofuranosamide (9).** To a solution of 6-(aminomethyl)-10-methoxy-7H-pyrido[4,3-*c*]carbazole (5; 1.108 g, 4 mmol) dissolved in 10 mL of anhydrous DMF were successively added at 0 °C, 1.17 g of 2,3,4,6-di-*O*-isopropylidene- $\alpha$ -L-xylo-2-hexulofuranosonic acid monohydrate, 612 mg (4 mmol) of HOBT, and 824 mg of DCC, each one being dissolved in DMF. The reaction was stirred at 0 °C during 2 h and at room temperature for 3 days. The solvent was evaporated in vacuo, and the residue dissolved in AcOEt. The precipitate was discarded as DCU and the organic phase washed successively with saturated aqueous solutions of citric acid,  $\text{NaHCO}_3$  and NaCl. After drying on  $\text{Na}_2\text{SO}_4$ , the organic phase was evaporated to yield 1 g of **9** (yield 47%). Mp: >260 °C. Anal. ( $\text{C}_{28}\text{H}_{31}\text{N}_3\text{O}_7$ ): C, H, N. CI-MS:  $\text{MH}^+ = m/e$  533.

**Dimerization of 7H-Pyridocarbazole 9 with 1,1'-Bis(2-chloroethyl)-4,4'-bipiperidine (10).** A 183-mg portion of 1,1'-bis(2-chloroethyl)-4,4'-bipiperidine (**3**; 0.5 mmol) dissolved in the minimal quantity of  $\text{H}_2\text{O}$  was added to 533 mg (1 mmol) of the substituted pyridocarbazole **9** dissolved in the minimal quantity of DMF. The mixture was stirred at 90 °C during 2 days. The solvent was evaporated and the dimer purified on Sephadex LH20 with  $\text{CH}_2\text{Cl}_2$ -MeOH 1:1 as eluent. Orange crystals were obtained. Mp: >260 °C. Yield: 10%. Formula:  $\text{C}_{72}\text{H}_{90}\text{N}_{10}\text{O}_{14}\text{Cl}_4$ . FAB-MS: 1290 =  $\text{MH}^+ = m/e$  1290,  $\text{M} + \text{Na} + \text{H}^+ = m/e$  1455.

**Deprotection of Dimer 10 (11).** A 500- $\mu\text{L}$  portion of  $\text{CH}_2\text{Cl}_2$  and 70  $\mu\text{L}$  (20 equiv) of TFA were added to 30 mg of **10** and stirred at 0 °C during 2 h and at room temperature overnight. The solvent and excess TFA were evaporated under vacuo, and the residue was washed several times with anhydrous  $\text{Et}_2\text{O}$  until neutralization occurred. A 25-mg sample of deprotected dimer **11** was obtained as a dark orange powder. Mp: >260. Yield: 75%. Formula:  $\text{C}_{60}\text{H}_{72}\text{N}_8\text{O}_{14} \cdot 4\text{CF}_3\text{CO}_2\text{H}$ . FAB-MS:  $\text{M}^+ = m/e$  1128,  $\text{M} + \text{Na} + \text{H}_3\text{O}^+ = m/e$  1169.

***tert*-Butyl 10-Methoxy-7H-pyrido[4,3-*c*]carbazole-6-carboxylate (18).** To a suspension of **2** (340 mg, 1.16 mmol) in anhydrous benzene (10 mL), at 90 °C, was added 4 equiv of *N,N*-dimethylformamide di-*tert*-butyl acetal dropwise, during 30 min. The reaction mixture was stirred, at 90 °C, for 45 min. The solution was cooled and then washed with  $\text{H}_2\text{O}$ , a saturated solution of  $\text{NaHCO}_3$ , and a saturated solution of NaCl. The resulting yellow solution was dried over sodium sulfate, filtered, and concentrated in vacuo. Ester **18** crystallized to yield 160 mg (40%). Mp: >260 °C. CI-MS:  $\text{MH}^+ = m/e$  348. Anal. ( $\text{C}_{21}\text{H}_{26}\text{N}_2\text{O}_3$ ): C, H, N.

***N*-[(*tert*-Butoxycarbonyl)methyl]-10-methoxy-7H-pyrido[4,3-*c*]carbazole-6-carboxamide (21).** To a solution of *tert*-butyl glycinate hydrochloride (120 mg, 0.72 mmol) and 1.1 equiv of TEA in anhydrous DMF (3 mL) were added successively at 0 °C a solution of 7H-pyridocarbazole-6-carboxylic acid (**2**; 210 mg) in DMF (3 mL), a solution of HOBT (110 mg) in DMF (3

mL), and a solution of EDC (138 mg) in DMF (3 mL). After 1 h, the mixture was allowed to come to room temperature and was stirred for 5 days. After evaporation of the solvent, the residue was triturated with 2% HCl and then centrifuged. The crystals were washed with water, 10% NaHCO<sub>3</sub>, water, and diethyl ether and then dried in vacuo to yield 150 mg (50%). Mp: >260 °C. CI-MS: M<sup>+</sup> = m/e 406. Anal. (C<sub>23</sub>H<sub>23</sub>N<sub>3</sub>O<sub>4</sub>): C, H, N.

**Dimerization of 7H-Pyridocarbazoles 18 and 21 with 1,1'-Bis(2-chloroethyl)-4,4'-bipiperidine (19 and 22).** A solution of 1 equiv of linking chain 3 in water was added dropwise to a solution of 2 equiv of the appropriate pyridocarbazole in hot DMF. The reaction was heated at 80 °C for 3 days with stirring and then allowed to cool to room temperature overnight. The resulting precipitate was filtered, thoroughly washed with cold DMF and then with diethyl ether, and dried in vacuo to give about 20% of the expected dimer. The filtrate was evaporated to dryness in vacuo and chromatographed over a Sephadex LH20 resin column (CH<sub>2</sub>Cl<sub>2</sub>-MeOH 1:1).

18 yielded 19 (40%). Mp: >260 °C. Anal. (C<sub>56</sub>H<sub>68</sub>N<sub>6</sub>O<sub>6</sub>Cl<sub>4</sub>): C, H, N. 21 yielded 22 (25%). Mp: >260 °C. Anal. (C<sub>60</sub>H<sub>74</sub>N<sub>8</sub>O<sub>8</sub>Cl<sub>4</sub>): C, H, N.

**Deprotection of the Dimers 19 and 22 (20 and 23).** The preceding dimers (0.04 mmol) were dissolved in TFA (100 μL) and CH<sub>2</sub>Cl<sub>2</sub> (100 μL), at 0 °C. After 1 h the mixture was allowed to come to room temperature and stirred for 1 h. The addition of dry diethyl ether (100 μL) led to the precipitation of crude compound. The solid was washed with ether (5 × 100 mL) and dried in vacuo.

19 yielded 20 (80%). Mp: >260 °C. Formula (C<sub>48</sub>H<sub>48</sub>N<sub>6</sub>O<sub>6</sub>·4CF<sub>3</sub>CO<sub>2</sub>H). FAB-MS: M<sup>+</sup> = m/e 805, M<sup>+</sup> + CF<sub>3</sub>COOH = m/e 918. HPLC: V<sub>r</sub> = 12.53 mL. <sup>1</sup>H NMR ((C<sup>2</sup>H<sub>5</sub>)<sub>2</sub>SO + TFA) (δ ppm from HMDS): 12.33 (s, 1 H, NH), 10.45 (s, 1 H, H<sub>1</sub>), 8.82 (s, 3 H, H<sub>5</sub> + H<sub>4</sub> + H<sub>3</sub>), 8.29 (s, 1 H, H<sub>11</sub>), 7.93 (d, 1 H, H<sub>6</sub>), 7.31 (d, 1 H, H<sub>9</sub>), 5.47 (m, 2 H, CH<sub>2</sub> (a)), 4.00 (s, 3 H, OCH<sub>3</sub>), 3.89 (m, 2 H, CH<sub>2</sub> (b)), 3.69 (m, 2 H, CH<sub>2</sub> (c<sub>eq</sub>)), 3.00 (m, 2 H, CH<sub>2</sub> (c<sub>ax</sub>)), 1.89 (m, 2 H, CH<sub>2</sub> (d<sub>eq</sub>)), 1.55 (m, 2 H, CH<sub>2</sub> (d<sub>ax</sub>)), 1.40 (m, 1 H, CH (e)).

22 yielded 23 (90%). Mp: >260 °C. Formula: C<sub>52</sub>H<sub>54</sub>N<sub>8</sub>O<sub>8</sub>·4CF<sub>3</sub>CO<sub>2</sub>H. FAB-MS: M<sup>+</sup> = m/e 919. M<sup>+</sup> + CF<sub>3</sub>COOH = m/e 1032. HPLC: V<sub>r</sub> = 12.08 mL. <sup>1</sup>H NMR ((C<sup>2</sup>H<sub>5</sub>)<sub>2</sub>SO + TFA) (δ ppm from HMDS): 12.35 (s, 1 H, NH), 10.40 (s, 1 H, H<sub>1</sub>), 9.67 (s, 1 H, NH), 8.85 (d, 1 H, H<sub>3</sub>), 8.76 (d, 1 H, H<sub>4</sub>), 8.65 (s, 1 H, H<sub>5</sub>), 8.31 (s, 1 H, H<sub>11</sub>), 7.91 (d, 1 H, H<sub>6</sub>), 7.31 (d, 1 H, H<sub>9</sub>), 5.45 (m, 2 H, CH<sub>2</sub> (a)), 4.11 (d, 2 H, CH<sub>2</sub>NH), 3.96 (s, 3 H, OCH<sub>3</sub>), 3.93 (m, 2 H, CH<sub>2</sub> (b)), 3.73 (m, 2 H, CH<sub>2</sub> (c<sub>eq</sub>)), 3.00 (m, 2 H, CH<sub>2</sub> (c<sub>ax</sub>)), 1.91 (m, 2 H, CH<sub>2</sub> (d<sub>eq</sub>)), 1.47 (m, 3 H, CH<sub>2</sub> (d<sub>ax</sub>) + CH (e)).

**Interaction with DNA.** The DNA apparent affinity constants, K<sub>a</sub>, were determined at 25 °C in 0.1 M Tris-HCl, 0.1 M NaCl buffer (pH 7.4) by fluorescence measurements based upon competition with the ethidium dimer synthesized in our laboratory.<sup>38</sup> Excitation and emission were selected through a monochromator. The fluorescence of ethidium dimer was excited at 540 nm and emission recorded at 610 nm. Ethidium dimer (6.4 × 10<sup>-7</sup> M) and calf thymus DNA (base pairs concentration: 1.6 × 10<sup>-6</sup> M) were equilibrated for 24 h before measurements with different concentrations of drug. The concentration of bound ethidium dimer per base pair was deduced according to the method of Gaugain et al.<sup>39</sup> The displacement curves were com-

puted as described and were compared to the experimental ones in order to evaluate the K<sub>a</sub> values. Viscometric measurements were performed at 25 °C by using the procedure already reported.<sup>40</sup> The intrinsic viscosity η of sonicated calf thymus DNA was measured in the absence (η<sub>0</sub>) and presence (η) of increasing concentrations of drug. Plotting log (η/η<sub>0</sub>) versus log (1 + 2r) where r is the number of bound ligand per nucleotide of DNA gives a slope, ΔL, which accounts for monointercalation (2 < ΔL < 3) or bisintercalation (3 < ΔL < 6).

**Drug Exposure and Cell-Survival Determination.** Exponentially growing L1210 cells were treated with different drug concentrations. Determinations of the dose effective in inhibiting 50% of the cell growth after 24-h exposure to the drug (ED<sub>50</sub>) and determination of the dose required to inhibit the cloning efficiency to a factor of 0.37 after a 24-h exposure to the drug (EC<sub>37</sub>) were performed by using the methods described in detail in a preceding paper.<sup>19</sup>

**Biological Testing.** Increase in life span expressed as T/C × 100 values of DBA2 mice inoculated with L1210 cells (10<sup>5</sup>) were determined in the same way as reported elsewhere.<sup>2</sup> The statistical significance of the results was determined by the Student's test.

The acute toxicity was determined by the usual procedure.<sup>2</sup> OD is the optimal dose. MTD is the highest dose that could be administered without causing animal death.

**Acknowledgment.** We are grateful to I. Leguen, J. Couprie, and S. Guerineau for their technical assistance, to Dr. A. Gouyette for mass spectra recording, and to C. Dupuis for typing the manuscript and realization of the figures. This work was supported by funds from the Comité de Paris de la Ligue Nationale Française contre le Cancer, the Institut National de la Santé et de la Recherche Médicale, the Centre National de la Recherche Scientifique, and the Université René Descartes.

**Registry No.** 1, 75525-72-3; 2, 75525-77-8; 3-2HCl, 5857-53-4; 4, 136881-20-4; 5, 109056-40-8; 6, 136881-21-5; Di-6, 136881-43-1; 7-2Cl·2HCl, 136910-79-7; Di-7, 75525-97-2; Di-7·4MeSO<sub>3</sub>H, 136910-89-9; Di-7b·2MeSO<sub>3</sub><sup>-</sup>, 136881-45-3; DI-7b·2MeSO<sub>3</sub><sup>-</sup>·2MeSO<sub>3</sub>H, 136910-90-2; 8-2CF<sub>3</sub>CO<sub>2</sub><sup>-</sup>, 136881-47-5; 8-2CF<sub>3</sub>CO<sub>2</sub><sup>-</sup>·4CF<sub>3</sub>CO<sub>2</sub>H, 136910-80-0; 9, 136910-81-1; 10-2Cl<sup>-</sup>, 136881-22-6; 11-2CF<sub>3</sub>CO<sub>2</sub><sup>-</sup>, 136910-83-3; 11-2CF<sub>3</sub>CO<sub>2</sub><sup>-</sup>·2CF<sub>3</sub>CO<sub>2</sub>H, 136910-84-4; 12, 136881-23-7; 13-2Cl<sup>-</sup>·2HCl, 136910-86-6; 14-2CF<sub>3</sub>CO<sub>2</sub><sup>-</sup>, 136881-49-7; 14-2CF<sub>3</sub>CO<sub>2</sub><sup>-</sup>·6CF<sub>3</sub>CO<sub>2</sub>H, 136881-26-0; 15, 136881-27-1; 16-2Cl<sup>-</sup>·2HCl, 136881-29-3; 17-2CF<sub>3</sub>CO<sub>2</sub><sup>-</sup>, 136881-51-1; 17-2CF<sub>3</sub>CO<sub>2</sub><sup>-</sup>·4CF<sub>3</sub>CO<sub>2</sub>H, 136910-87-7; 18, 136881-30-6; 19-2Cl<sup>-</sup>·2HCl, 136881-32-8; 20-2CF<sub>3</sub>CO<sub>2</sub><sup>-</sup>, 136881-34-0; 20-2CF<sub>3</sub>CO<sub>2</sub><sup>-</sup>·2CF<sub>3</sub>CO<sub>2</sub>H, 136881-35-1; 21, 136910-88-8; 22-2Cl<sup>-</sup>·2HCl, 136881-37-3; 23-2CF<sub>3</sub>CO<sub>2</sub><sup>-</sup>, 136881-39-5; 23-2CF<sub>3</sub>CO<sub>2</sub><sup>-</sup>·2CF<sub>3</sub>CO<sub>2</sub>H, 136881-40-8; Di-TH, 136881-41-9; Di-TH·2MeSO<sub>3</sub>H, 136881-42-0; Boc-Lys(Boc), 2483-46-7; Boc-Glu-OBu-t, 24277-39-2; Gly-OtBu-HCl, 27532-96-3; N-Me-ditercalinium, 136881-52-2; 10-methoxy-7H-pyrido[4,3-c]carbazole, 62099-76-7; 2-methyl-10-methoxy-7H-pyrido[4,3-c]-2-carbazolium iodide, 62099-82-5; 2,3:4,6-di-O-isopropylidene-α-L-xyllo-2-hexulofuranosonic acid, 136881-53-3.

(38) Gaugain, B.; Barbet, J.; Oberlin, R.; Roques, B. P.; Le Pecq, J. B. DNA bifunctional intercalators: 1. Synthesis and conformational properties of an ethidium homodimer and of an acridine ethidium heterodimer. *Biochemistry* 1978, 17, 5071-5078.

(39) Gaugain, B.; Barbet, J.; Capelle, N.; Roques, B. P.; Le Pecq, J. B. DNA bifunctional intercalators. 2. Fluorescence properties and DNA binding interaction of an ethidium homodimer and an acridine ethidium heterodimer. *Biochemistry* 1978, 17, 5078-5088.

(40) Saucier, J. M.; Festy, B.; Le Pecq, J. B. The change of the torsion of the helix caused by intercalation. II. Measurement of the relative change of torsion induced by various intercalating drugs. *Biochimie* 1971, 53, 973-980.