

# Side Chain Modified 5-Deazafolate and 5-Deazatetrahydrofolate Analogues as Mammalian Folylpolylglutamate Synthetase and Glycinamide Ribonucleotide Formyltransferase Inhibitors: Synthesis and in Vitro Biological Evaluation<sup>1</sup>

Andre Rosowsky,\*† Ronald A. Forsch,† Valerie E. Reich,‡ James H. Freisheim,§ and Richard G. Moran‡

Dana-Farber Cancer Institute and Department of Biological Chemistry and Molecular Pharmacology, Harvard Medical School, Boston, Massachusetts 02115, Department of Biochemistry and the Norris Comprehensive Cancer Center, University of Southern California, Los Angeles, California 90033, and Department of Biochemistry and Molecular Biology, Medical College of Ohio, Toledo, Ohio 43699. Received October 4, 1991

5-Deazafolate and 5-deazatetrahydrofolate (DATHF) analogues with the glutamic acid side chain replaced by homocysteic acid (HCysA), 2-amino-4-phosphonobutanoic acid (APBA), and ornithine (Orn) were synthesized as part of a larger program directed toward inhibitors of folylpolylglutamate synthetase (FPGS) as probes of the FPGS active site and as potential therapeutic agents. The tetrahydro compounds were also of interest as non-polyglutamatable inhibitors of the purine biosynthetic enzyme glycinamide ribonucleotide formyltransferase (GARFT). Reductive coupling of *N*<sup>2</sup>-acetamido-6-formylpyrido[2,3-*d*]pyrimidin-4(3*H*)-one with 4-aminobenzoic acid, followed by *N*<sup>10</sup>-formylation, mixed anhydride condensation of the resultant *N*<sup>2</sup>-acetyl-*N*<sup>10</sup>-formyl-5-deazapteroic acid with *L*-homocysteic acid, and removal of the *N*<sup>2</sup>-acetyl and *N*<sup>10</sup>-formyl groups with NaOH, afforded *N*-(5-deazapteroyl)-*L*-homocysteic acid (5-dPteHCysA). Mixed anhydride condensation of *N*<sup>2</sup>-acetyl-*N*<sup>10</sup>-formyl-5-deazapteroic acid with methyl *D,L*-2-amino-4-(diethoxyphosphinyl)butanoic acid, followed by consecutive treatment with Me<sub>3</sub>SiBr and NaOH, yielded *D,L*-2-[(5-deazapteroyl)amino]-4-phosphonobutanoic acid (5-dPteAPBA). Treatment with NaOH alone led to retention of one ethyl ester group on the phosphonate moiety. Catalytic hydrogenation of *N*<sup>2</sup>-acetyl-*N*<sup>10</sup>-formyl-5-deazapteroic acid followed by mixed anhydride condensation with methyl *L*-homocysteate and deprotection with NaOH afforded *N*-(5,6,7,8-tetrahydro-5-deazapteroyl)-*L*-homocysteic acid (5-dH<sub>4</sub>PteHCysA). Similar chemistry starting from methyl *D,L*-2-amino-4-(diethoxyphosphinyl)butanoic acid and methyl *N*<sup>2</sup>-(benzyloxycarbonyl)-*L*-ornithinate yielded *D,L*-2-[(5-deaza-5,6,7,8-tetrahydropteroyl)amino]-4-phosphonobutanoic acid (5-dH<sub>4</sub>Pte-APBA) and *N*<sup>2</sup>-(5-deaza-5,6,7,8-tetrahydropteroyl)-*L*-ornithine (5-dH<sub>4</sub>PteOrn), respectively. The 5-deazafolate analogues were inhibitors of mouse liver FPGS, and the DATHF analogues inhibited both mouse FPGS and mouse leukemic cell GARFT. Analogues with HCysA and monoethyl APBA side chains were less active as FPGS inhibitors than those containing an unesterified γ-PO(OH)<sub>2</sub> group, and their interaction with the enzyme was noncompetitive against variable folyl substrate. In contrast, Orn and APBA analogues obeyed competitive inhibition kinetics and were more potent, with *K*<sub>1</sub> values as low as 30 nM. Comparison of the DATHF analogues as GARFT inhibitors indicated that the Orn side chain diminished activity relative to DATHF, but that the compounds with γ-sulfonate or γ-phosphonate substitution retained activity, with *K*<sub>1</sub> values in the submicromolar range. The best GARFT inhibitor was the 5-dH<sub>4</sub>PteAPBA diastereomer mixture, with a *K*<sub>1</sub> of 47 nM versus 65 nM for DATHF. None of the compounds showed activity against cultured WI-L2 or CEM human leukemic lymphoblasts at concentrations of up to 100 μM. We conclude that linking the 5-deazapteroyl moiety to these amino acid side chains previously found inhibitory to FPGS enhances binding to FPGS, and that negatively charged groups at the γ-position of the DATHF analogues allow maintenance of GARFT inhibition. However, inefficient cellular uptake is an obstacle to the use of these potential dual inhibitors of FPGS and GARFT as therapeutic agents.

Folate analogues with a homocysteic acid (HCysA),<sup>2</sup> 2-amino-4-phosphonobutanoic acid (APBA),<sup>3</sup> or ornithine (Orn)<sup>4</sup> side chain in place of glutamic acid have been studied previously in our laboratories as part of a broader program directed toward the discovery of inhibitors of folylpolylglutamate synthetase (FPGS), the enzyme responsible for the intracellular conversion of folates and antifolates to noneffluxing γ-polyglutamyl conjugates.<sup>5</sup> The underlying rationale for the use of FPGS inhibitors as therapeutic agents, which has been discussed elsewhere in greater detail,<sup>6</sup> is that the ability to form polyglutamates of reduced folate cofactors is essential for normal cell division.<sup>7</sup> Compounds that we or others have synthesized to date as FPGS inhibitors include the folic acid analogue 1,<sup>8a</sup> the aminopterin (AMT) and methotrexate (MTX) analogues 2-7,<sup>2-6,8a</sup> the 5,8-dideazafolic acid analogues 8 and 9,<sup>10,11</sup> the 5,8-dideazaAMT analogues 10 and 11,<sup>10,11</sup> and most recently the 5- and 8-deazaAMT analogues 12 and 13.<sup>11</sup>

The most potent FPGS inhibitors among the folate analogues studied to date have been those (1, 6-12) with an Orn side chain.<sup>4,8-11</sup> However the potency of these compounds against intact tumor cells is constrained by the

Scheme I<sup>a</sup>

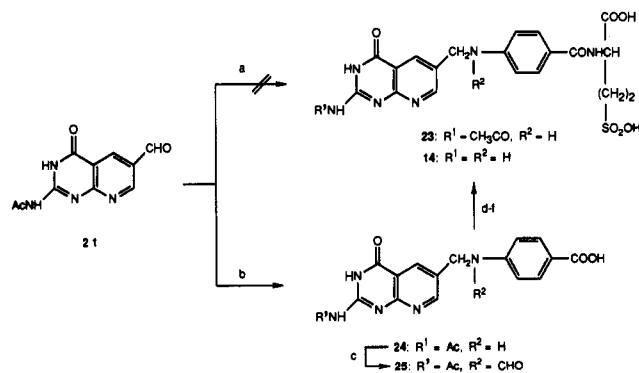

<sup>a</sup> (a) 4-O<sub>2</sub>NC<sub>6</sub>H<sub>4</sub>CONHCH(COOH)CH<sub>2</sub>CH<sub>2</sub>SO<sub>2</sub>OH (22)/H<sub>2</sub>/Ra Ni/AcOH; (b) 4-H<sub>2</sub>NC<sub>6</sub>H<sub>4</sub>CO<sub>2</sub>H/BH<sub>3</sub>·Et<sub>3</sub>N/AcOH; (c) HCO<sub>2</sub>H; (d) *i*-BuOCOC1/Et<sub>3</sub>N/DMF; (e) H<sub>2</sub>NCH(COOH)CH<sub>2</sub>CH<sub>2</sub>SO<sub>2</sub>OH bis-(benzyltrimethylammonium) salt; (f) NaOH.

positive charge on the ornithine δ-amino group at physiologic pH, which is likely to inhibit efficient transport

\* Dana-Farber Cancer Institute and Harvard Medical School.

† University of Southern California.

‡ Medical College of Ohio.

(1) Paper 46 in this series. For previous paper, see: Bader, H.; Rosowsky, A. First use of the Taylor Pteridine Synthesis as a Route to Polyglutamate Derivatives of Antifolates. *J. Org. Chem.* 1991, 56, 3386-3391.

across the plasma membrane. Thus, FPGS inhibitors with the glutamate moiety replaced by acidic amino acids

- (2) (a) Rosowsky, A.; Moran, R. G.; Forsch, R.; Colman, P.; Wick, M. Methotrexate Analogues. XVII. Antitumor activity of 4-Amino-4-deoxy- $N^{10}$ -methylpteroyl-D,L-homocysteic Acid and its Dual Inhibition of Dihydrofolate Reductase and Folyl Polyglutamate Synthetase. *Biochem. Pharmacol.* 1984, 33, 155-161. (b) Rosowsky, A.; Forsch, R. A.; Freisheim, J. H.; Moran, R. G.; Wick, M. Methotrexate Analogues. 19. Replacement of the Glutamate Side Chain in Classical Antifolates by L-Homocysteic Acid and L-Cysteic Acid: Effect on Enzyme Inhibition and Antitumor Activity. *J. Med. Chem.* 1984, 27, 600-604. (c) Moran, R. G.; Rosowsky, A.; Colman, P. D.; Forsch, R.; Solan, V. C.; Harvison, P.; Kalman, T. I. Structural Features of Folate Analogs that Determine Substrate or Inhibitor Activity for Mammalian Folyl polyglutamate Synthetase. In *Proceedings of the Second Workshop on Folyl and Antifoly Polyglutamates*; Goldman, I. D., Ed.; Praeger Press: New York, 1985; pp 51-64.
- (3) (a) Rosowsky, A.; Moran, R. G.; Forsch, R. A.; Radike-Smith, M.; Colman, P. D.; Wick, M. M.; Freisheim, J. H. Methotrexate Analogues. 27. Dual Inhibition of Dihydrofolate Reductase and Folyl polyglutamate Synthetase by Methotrexate and Aminopterin Analogues with a  $\gamma$ -Phosphonate Group in the Side Chain. *Biochem. Pharmacol.* 1986, 35, 3327-3333. (b) Rosowsky, A.; Forsch, R. A.; Moran, R. G.; Kohler, W.; Freisheim, J. H. Methotrexate Analogues. 32. Chain Extension,  $\alpha$ -Carboxyl Deletion, and  $\gamma$ -Carboxyl Replacement by Sulfonate and Phosphonate. Effect on Enzyme Binding and Cell-Growth Inhibition. *J. Med. Chem.* 1988, 31, 1326-1331.
- (4) (a) Rosowsky, A.; Freisheim, J. H.; Moran, R. G.; Solan, V. C.; Bader, H.; Wright, J. E.; Radike-Smith, M. Methotrexate Analogues. 26. Inhibition of Dihydrofolate Reductase and Folyl polyglutamate Synthetase Activity and in Vitro Tumor Cell Growth by Methotrexate and Aminopterin Analogues Containing a Basic Amino Acid Side Chain. *J. Med. Chem.* 1986, 29, 655-660. (b) Clarke, L.; Rosowsky, A.; Waxman, D. J. Inhibition of Human Liver Folyl polyglutamate Synthetase by Non- $\gamma$ -glutamylatable Antifolate Analogs. *Mol. Pharmacol.* 1987, 31, 122-127. (d) Rosowsky, A.; Bader, H.; Forsch, R. A. Synthesis of the Folyl polyglutamate Synthetase Inhibitor  $N^{\alpha}$ -Pteroyl-L-ornithine and its  $N^{\delta}$ -Benzoyl and  $N^{\delta}$ -Hemiphthaloyl Derivatives, and an Improved Synthesis of  $N^{\alpha}$ -(4-Amino-4-deoxypteroyl)- $N^{\delta}$ -hemiphthaloyl-L-ornithine. *Pteridines* 1989, 1, 91-98.
- (5) For a comprehensive review of FPGS and its role in folate metabolism and antifolate chemotherapy, see: McGuire, J. J.; Coward, J. K. Pteroyl polyglutamates: Biosynthesis, Degradation, and Function. In *Folates and Pterins*; Blakley, R. L., Benkovic, S. J., Eds.; Wiley Interscience: New York, 1984; pp 135-190.
- (6) (a) Moran, R. G.; Colman, P. D.; Rosowsky, A.; Forsch, R. A.; Chan, K. K. Structural Features of 4-Amino Antifolates Required for Substrate Activity with Mammalian Folyl polyglutamate Synthetase. *Mol. Pharmacol.* 1985, 27, 156-166. (b) Moran, R. G.; Colman, P. D.; Rosowsky, A. Structural Requirements for the Activity of Antifolates as Substrates for Mammalian Folyl polyglutamate Synthetase. *Nat. Cancer Inst. Monogr.* 1987, 5, 133-138. (c) McGuire, J. J.; Piper, J. R.; Coward, J. K.; Galivan, J. Folate Analog Nonsubstrates and Inhibitors of Folyl polyglutamate Synthetase as Potential Cancer Chemotherapy Drugs. *Nat. Cancer Inst. Monogr.* 1987, 5, 139-144. (d) Rosowsky, A.; Moran, R. G.; Freisheim, J. H.; Bader, H.; Forsch, R. A.; Solan, V. C. Synthesis and Biologic Activity of New Side-Chain-Altered Methotrexate and Aminopterin Analogs with Dual Inhibitory Action Against Dihydrofolate Reductase and Folyl polyglutamate Synthetase. *Nat. Cancer Inst. Monogr.* 1987, 5, 145-152.
- (7) (a) McBurney, M. W.; Whitmore, G. F. Isolation and Biochemical Characterization of Folate Deficient Mutants of Chinese Hamster Cells. *Cell* 1974, 2, 173-182. (b) Taylor, R. T.; Hanna, M. L. Folate-Dependent Enzymes in Cultured Chinese Hamster Cells: Folyl polyglutamate Synthetase and its Absence in Mutants Auxotrophic for Glycine + Adenosine + Thymidine. *Arch. Biochem. Biophys.* 1977, 181, 331-334. (c) Moran, R. G. Characterization of the Function of Mammalian Folate Polyglutamate Synthetase. *Adv. Exper. Med. Biol.* 1983, 163, 327-339.
- continue to be of interest. The observation has also been made that the inhibitory activities of competitive inhibitors of FPGS that differ in the fused heterocyclic and para-aminobenzoyl region vary in parallel with the relative substrate  $K_m$  values of the corresponding compounds with a glutamate side chain. Although exceptions to this empirical rule existed, the trend was strong enough to make us think that a 5-deazatetrahydropteroyl moiety would enhance the inhibition of FPGS previously described for analogous pteridine compounds with an Orn, APBA, or HCysA side chain. In the present paper we report the results of studies on the heretofore undescribed 5-deazafolic acid analogues 14-16 (5-dPteHCysA, 5-dPteAPBA, ethyl 5-dPteAPBA) and the 5-deazatetrahydrofolic acid (DATHF) analogues 17-20 (5-dH<sub>4</sub>PteHCysA, 5-dH<sub>4</sub>PteAPBA, ethyl 5-dH<sub>4</sub>PteAPBA, 5-dH<sub>4</sub>PteOrn). The latter four compounds were judged to be especially attractive because reduction of the B-ring in 1 and other folate analogues is known to increase FPGS binding,<sup>6a,6b,12</sup> and because the reduced analogue DATHF<sup>13a</sup> is a potent inhibitor of the enzyme glycylamide ribonucleotide formyltransferase (GARFT),<sup>13b</sup> which is currently viewed with great interest as a target for the design of antifolates.<sup>13-17</sup>
- (8) (a) George, S.; Cichowicz, D. J.; Shane, B. Mammalian Folyl poly- $\gamma$ -glutamate Synthetase. 3. Specificity for Folate Analogues. *Biochemistry* 1987, 26, 522-529. (b) Sato, J.; Moran, R. G. Interaction of Methotrexate and Citrovorum Factor at Folyl polyglutamate Synthetase. *Proc. Am. Assoc. Cancer Res.* 1984, 25, 312.
- (9) (a) Piper, J. R.; McCaleb, G. S.; Montgomery, J. A.; Schmid, F. A.; Sirotak, F. M. Syntheses and Evaluation as Antifolates of MTX Analogues Derived from 2, $\omega$ -Diaminoalkanoic Acids. *J. Med. Chem.* 1985, 28, 1016-1025. (b) McGuire, J. J.; Hsieh, P.; Franco, C. T.; Piper, J. R. Folyl polyglutamate Synthetase Inhibition and Cytotoxic Effects of Methotrexate Analogs Containing 2, $\omega$ -Diaminoalkanoic Acids. *Biochem. Pharmacol.* 1986, 35, 2607-2613. (c) McGuire, J. J.; Bolanowska, W. E.; Piper, J. R. Structural Specificity of Inhibition of Human Folyl polyglutamate Synthetase by Ornithine-Containing Folate Analogs. *Biochem. Pharmacol.* 1988, 37, 3931-3939.
- (10) (a) Cichowicz, D. J.; Hynes, J. B.; Shane, B. Substrate Specificity of Mammalian Folyl poly- $\gamma$ -glutamate Synthetase for 5,8-Dideazafolates and 5,8-Dideaza Analogues of Aminopterin. *Biochim. Biophys. Acta* 1988, 957, 363-369. (b) Patil, S. A.; Shane, B.; Freisheim, J. H.; Singh, S. K.; Hynes, J. B. Inhibition of Mammalian Folyl polyglutamate Synthetase and Human Dihydrofolate Reductase by 5,8-Dideaza Analogues of Folic Acid and Aminopterin Bearing a Terminal L-Ornithine. *J. Med. Chem.* 1989, 32, 1559-1565.
- (11) Rosowsky, A.; Forsch, R. A.; Bader, H.; Freisheim, J. H. Synthesis and in Vitro Biological Activity of New Deaza Analogues of Folic Acid, Aminopterin, and Methotrexate with an L-Ornithine Side Chain. *J. Med. Chem.* 1991, 34, 1447-1454.
- (12) (a) Moran, R. G.; Colman, P. A. *Biochemistry* 1984, 23, 4580-4589. (b) Taylor, E. C.; Harrington, P. J.; Fletcher, S. R.; Beardsley, G. P.; Moran, R. G. Synthesis of the Antileukemic Agents 5,10-Dideazaaminopterin and 5,10-Dideaza-5,6,7,8-tetrahydroaminopterin. *J. Med. Chem.* 1985, 28, 914-921. (c) Moran, R. G.; Colman, P. D.; Jones, T. R. Relative Substrate Activities of Structurally Related Pteridine, Quinazoline, and Pyrimidine Analogs for Mouse Liver Folyl polyglutamate Synthetase. *Mol. Pharmacol.* 1989, 36, 736-743.
- (13) (a) Taylor, E. C.; Hamby, J. M.; Shih, C.; Grindey, G. B.; Rinzel, S. M.; Beardsley, G. P.; Moran, R. G. Synthesis and Antitumor Activity of 5-Deaza-5,6,7,8-tetrahydrofolic Acid and Its  $N^{10}$ -Substituted Analogues. *J. Med. Chem.* 1989, 32, 1517-1522. (b) Baldwin, S. W.; Tse, A.; Gossett, L. S.; Taylor, E. C.; Rosowsky, A.; Shih, C.; Moran, R. G. Structural Features of 5,10-Dideaza-5,6,7,8-tetrahydrofolate That Determine Inhibition of Mammalian Glycylamide Ribonucleotide Formyltransferase. *Biochemistry* 1991, 30, 1997-2006.

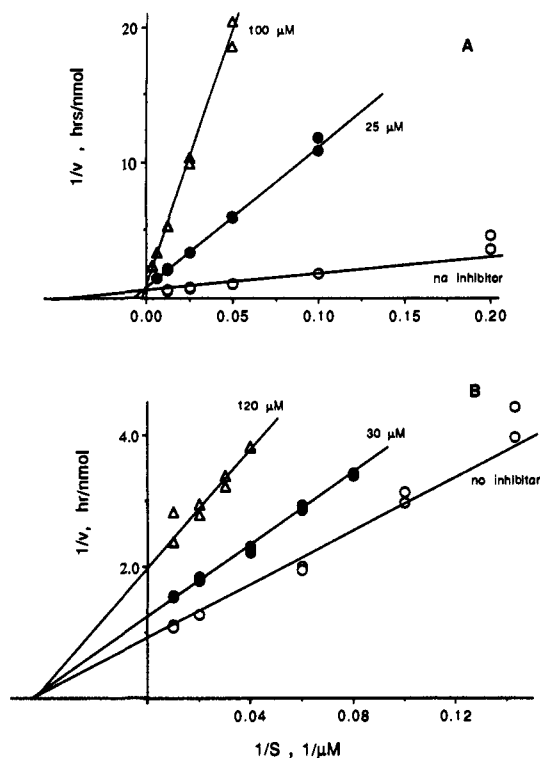

**Figure 1.** Patterns of inhibition of mouse liver FPGS by the reduced phosphonate 18 (A) and reduced sulfonate 17 (B). Inhibitors were incubated with the indicated concentrations of AMT in the presence of ATP, [ $^3\text{H}$ ]glutamic acid, and KCl in Tris buffer for 1 h, and the product was isolated by charcoal adsorption as described earlier.<sup>6a,12a</sup> The concentration of inhibitors used are indicated above each line. Note the difference in scale of the abscissas in A and B.

We reasoned that if compounds such as 17–20 would bind tightly to FPGS as well as GARFT, potentiation of activity against GARFT might occur as a result of interference with cellular polyglutamation of the natural cofactor for this enzyme. The extent of such potentiation would depend

on the tightness of binding to FPGS and the degree of depletion of endogenous reduced folates. Moreover, there was the intriguing possibility that non-polyglutamatable GARFT inhibitors that do not rely on polyglutamation for activity might be active against tumors with acquired antifolate resistance based on decreased FPGS activity, an idea first suggested in 1983 as an approach to the design of novel DHFR inhibitors targeted against FPGS-deficient tumors.<sup>18</sup> The potential importance of GARFT inhibitors whose activity does not rely on polyglutamation is indicated by the recent observation that altered FPGS is the major cause of resistance to 5,10-dideaza-5,6,7,8-tetrahydrofolate (DDATHF) in CEM leukemic lymphoblasts.<sup>14c</sup>

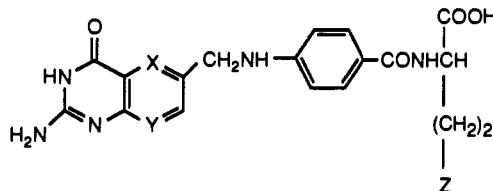

- 1: X = Y = N; Z = CH<sub>2</sub>NH<sub>2</sub>  
 8,9: X = CH, CCl; Y = CH; Z = CH<sub>2</sub>NH<sub>2</sub>  
 14: X = CH, Y = N; Z = SO<sub>2</sub>OH  
 15: X = CH, Y = N; Z = PO(OH)<sub>2</sub>  
 16: X = CH, Y = N; Z = PO(OH)(OEt)

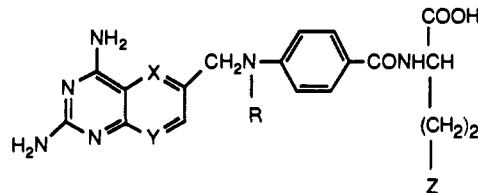

- 2,3: R = H, Me; X = Y = N; Z = SO<sub>2</sub>OH  
 4,5: R = H, Me; X = Y = N; Z = PO(OH)<sub>2</sub>  
 6,7: R = H, Me; X = Y = N; Z = CH<sub>2</sub>NH<sub>2</sub>  
 10,11: R = H; X = CH, CCl; Y = CH; Z = CH<sub>2</sub>NH<sub>2</sub>  
 12: R = H; X = CH, Y = N; Z = CH<sub>2</sub>NH<sub>2</sub>  
 13: R = H; X = N, Y = CH; Z = CH<sub>2</sub>NH<sub>2</sub>

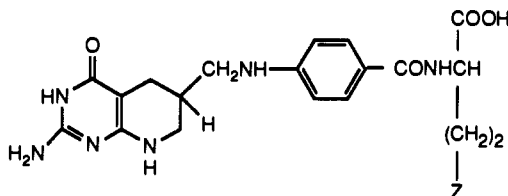

- 17: Z = SO<sub>2</sub>OH  
 18: Z = PO(OH)<sub>2</sub>  
 19: Z = PO(OH)(OEt)  
 20: Z = CH<sub>2</sub>NH<sub>2</sub>

## Chemistry

Having recently found 2-acetamido-6-formyl-4(3*H*)-oxypyrido[2,3-*d*]pyrimidine (21) to be a satisfactory building block for the synthesis of the ornithine analogue of 5-deazafolate,<sup>11</sup> we chose to utilize the same compound in the present work. The preparation of the nonreduced sulfonic and phosphonic acid analogues 14–16 is depicted in Schemes I–III, and that of the tetrahydro analogues 17–20 is shown in Scheme IV.

By analogy with our earlier work in this series,<sup>11</sup> we initially assumed that 14 would be accessible via *N*-(4-

- (14) (a) Beardsley, G. P.; Moroson, B. A.; Taylor, E. C.; Moran, R. G. A New Folate Antimetabolite, 5,10-Dideaza-5,6,7,8-tetrahydrofolate Is a Potent Inhibitor of de Novo Purine Synthesis. *J. Biol. Chem.* 1989, 264, 328–333. (b) Moran, R. G.; Baldwin, S. W.; Taylor, E. C.; Shih, C. The 6*S*- and 6*R*-Diastereomers of 5,10-Dideaza-5,6,7,8-tetrahydrofolate Are Equiaactive Inhibitors of de Novo Purine Synthesis. *J. Biol. Chem.* 1989, 264, 21047–21051. (c) Pizzorno, G.; Sokoloski, J. A.; Cashmore, A. R.; Moroson, B. A.; Cross, A. D.; Beardsley, G. P. Intracellular Metabolism of 5,10-Dideazatetrahydrofolic Acid in Human Leukemia Cell Lines. *Mol. Pharmacol.* 1991, 39, 85–89.
- (15) Boschelli, D. H.; Webber, S.; Whiteley, J. M.; Oronsky, A. L.; Kerwar, S. S. Synthesis and Biological Properties of 5,10-Dideaza-5,6,7,8-tetrahydrofolic Acid. *Arch. Biochem. Biophys.* 1988, 265, 43–49.
- (16) Piper, J. R.; McCaleb, G. S.; Montgomery, J. A.; Kisiuk, R. L.; Gaumont, Y.; Thorndike, J.; Sirotnak, F. M. Synthesis and Antifolate Activity of 5-Methyl-5,10-dideaza Analogues of Aminopterin and Folic Acid and an Alternative Synthesis of 5,10-Dideazatetrahydrofolic Acid, a Potent Inhibitor of Glycinamide Ribonucleotide Formyltransferase. *J. Med. Chem.* 1988, 31, 2164–2169.
- (17) (a) Kelley, J. L.; McLean, E. W.; Cohn, N. K.; Edelman, M. P.; Duch, D. S.; Smith, G. K.; Hanlon, M. H.; Ferone, R. Synthesis and Biological Activity of an Acyclic Analogue of 5,6,7,8-Tetrahydrofolic Acid, *N*-[4-[[3-(2,4-Diamino-1,6-dihydro-6-oxo-5-pyrimidinyl)propyl]amino]benzoyl]-L-glutamic Acid. *J. Med. Chem.* 1990, 33, 561–567. (b) Hanlon, M. H.; Ferone, R.; Mullin, R. J.; Keith, B. R. In Vivo and in Vitro Metabolism of 5-Deazacyclotetrahydrofolate, an Acyclic Tetrahydrofolate Analogue. *Cancer Res.* 1990, 50, 3207–3211.

- (18) Rosowsky, A.; Forsch, R.; Uren, J.; Wick, M.; Kumar, A. A.; Freisheim, J. H. Methotrexate Analogues. 20. Replacement of Glutamate by Longer-Chain Amino Diacids: Effects on Dihydrofolate Reductase Inhibition, Cytotoxicity, and in Vivo Antitumor Activity. *J. Med. Chem.* 1983, 26, 1719–1724.

nitrobenzoyl)-L-homocysteic acid (22), a compound not previously described in the literature. It was envisaged that 22 could be reduced to the corresponding 4-amino derivative, and that the latter could be condensed with 21 in the presence of hydrogen and Raney nickel (Ra Ni) as had been done to obtain 1.<sup>11</sup> Furthermore, since H<sub>2</sub>/Ra Ni should also reduce the nitro group in 22 we reasoned that it might be possible to effect conversion of 22 to 23 in one step. Alkaline hydrolysis would then yield 14. Compound 22 was obtained in 82% yield by reaction of L-homocysteic acid with 4-nitrobenzoyl chloride. While reduction of the nitro group with H<sub>2</sub>/Ra Ni<sup>19</sup> or H<sub>2</sub>NNH<sub>2</sub>/Ra Ni<sup>20</sup> succeeded (NMR), we were unable to achieve coupling of the amine with 21, or to effect reduction and coupling in a single step.<sup>19</sup> Although it is possible that this lack of success was due to the use of commercially available catalyst (grade W-2) rather than activated Ra Ni (e.g., grade W-6),<sup>21</sup> the hydrogenation approach was abandoned in favor of the alternative shown in Scheme I, wherein 21 was reductively coupled to 4-aminobenzoic acid with BH<sub>3</sub>·Et<sub>3</sub>N in glacial AcOH<sup>12a</sup> and the resulting product 24 (55%) was converted to its N<sup>10</sup>-formyl derivative 25 (93%) by heating with 98% HCOOH. Mixed carboxylic-carbonic anhydride activation (*i*-BuOCOCl/Et<sub>3</sub>N) of 25 followed by treatment with the bis(benzyltrimethylammonium) salt of L-homocysteic acid and direct alkaline hydrolysis of the N<sup>2</sup>-acetyl and N<sup>10</sup>-formyl groups with NaOH (80 °C, 30 min) afforded 5-dPteHCysA (14) in 27% yield. The product was isolated as a hydrated ammonium salt after purification by DEAE-cellulose ion-exchange chromatography (0.4 M NH<sub>4</sub>HCO<sub>3</sub>) followed by reversed-phase HPLC (3% MeCN in 0.05 M NH<sub>4</sub>OAc, pH 6.7). The bis(benzyltrimethylammonium) salt of L-homocysteic acid, which we decided to use in the coupling reaction when trial experiments showed L-homocysteic acid to be virtually insoluble in DMF, was prepared by adding 40% benzyltrimethylammonium methoxide in MeOH to a solution of the amino acid in H<sub>2</sub>O. The solvents were evaporated under reduced pressure, and the gummy salt was taken up immediately in dry DMF and added to the mixed anhydride of 20 without further purification. Use of the bis(benzyltrimethylammonium) salt to solubilize L-homocysteic acid represents an alternative to methylation and silylation, which we have used in the past, but remains a less than optimal method. The modest yields consistently obtained in peptide coupling reactions of L-homocysteic acid with activated pteric acid derivatives suggest that better strategies for improving the solubility of this amino acid would be very desirable.

The synthesis of  $\gamma$ -phosphonic acid analogues of MTX and AMT was previously carried out from the appropriate 4-amino-4-deoxyptericoic acids and unprotected D,L-2-amino-4-phosphonobutanoic acid, but yields in the coupling reactions were only moderate.<sup>2</sup> Accordingly, we decided to use a triester of D,L-2-amino-4-phosphonobutanoic acid, rather than the amino acid itself, in the synthesis of the 5-deaza analogue 15. Treatment of D,L-

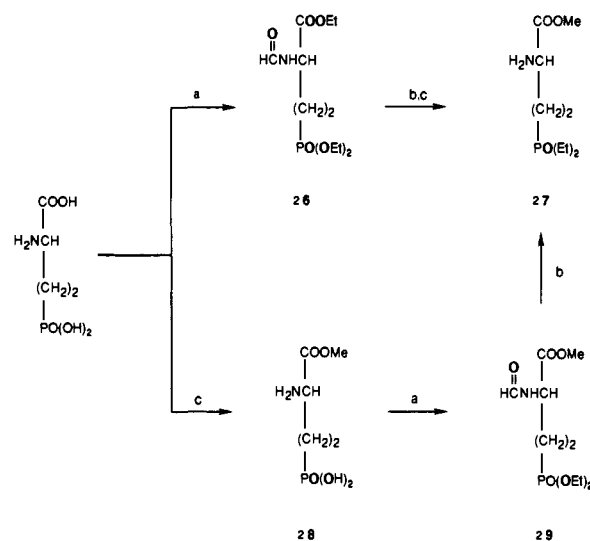
Scheme II<sup>a</sup>

<sup>a</sup> (a) HC(OEt)<sub>3</sub>; (b) HCl/MeOH; (c) SOCl<sub>2</sub>/MeOH.

2-amino-4-phosphonobutanoic acid with triethyl orthoformate<sup>22</sup> for several days afforded the expected *N*-formyl triester 26, which on further reaction with MeOH/HCl/SOCl<sub>2</sub> underwent amide cleavage and concomitant carboxyl ester exchange (Scheme II). The resultant mixed triester 27 was a gum, but could be isolated in crystalline form as a sesquioxalate salt. That ester exchange had occurred in 27 was evident from the <sup>1</sup>H-NMR spectrum, which contained a three-proton singlet at  $\delta$  3.75 (CO<sub>2</sub>Me) along with two ethyl signals at  $\delta$  1.23 (t, POCH<sub>2</sub>CH<sub>3</sub>) and  $\delta$  4.00 (q, POCH<sub>2</sub>CH<sub>3</sub>) and no protons corresponding to a CO<sub>2</sub>Et group. A more convenient route to 27 was to first convert D,L-2-amino-4-phosphonobutanoic acid to methyl ester 28 using MeOH/SOCl<sub>2</sub>, and to treat the latter sequentially with triethyl orthoformate to form the *N*-formyl triester 29 and with HCl/MeOH to cleave the *N*-formyl group. Evaporation of the acidolysis mixture yielded the hydrochloride salt of 29 in higher overall yield and in a sufficient state of purity to proceed directly to the next stage of the synthesis (Scheme III). Acylation of 27 with 4-nitrobenzoyl chloride followed by catalytic hydrogenation over 5% Pd-C afforded 30 and 31. Our initial plan was to remove the ester groups at this stage; however, while treatment with Me<sub>3</sub>SiBr converted 31 into the diacid 32 without difficulty, subsequent catalytic hydrogenation yielded a very hygroscopic product which was hard to purify and failed to analyze correctly for the expected amine. Accordingly, we decided to keep the ester groups in place until the end of the synthesis. Reductive amination of 21 with 31 in the presence of BH<sub>3</sub>·Et<sub>3</sub>N afforded the protected coupling product 33 (33%). Sequential reaction of 33 with Me<sub>3</sub>SiBr (to cleave the ester groups) and NaOH (to cleave the N<sup>2</sup>-acetyl group) then gave the target structure 15 (5-dPteAPBA, 73%), whereas treatment with NaOH alone left one of the ethyl ester groups intact, yielding the monoethyl ester 16 (ethyl 5-dPteAPBA, 58%). Both products were obtained as hydrated ammonium salts after preparative HPLC on C<sub>18</sub> silica gel with 5% MeCN in 0.05 M NH<sub>4</sub>OAc, pH 6.7, as the eluent.

The approach we chose to follow for the synthesis of the tetrahydro analogues 17–20 (Scheme IV) was to condense

(19) Elslager, E. F.; Davoll, J. Synthesis of Fused Pyrimidines as Folate Antagonists. In *Lectures in Heterocyclic Chemistry*; Castle, R. N.; Townsend, L. B., Eds.; Hetero Corp.: Orem, UT, 1974; Vol. 2, p S97.

(20) Yuste, F.; Saldana, M.; Walls, F. Selective Reduction of Aromatic Nitro Compounds Containing O- and N-Benzyl Groups with Hydrazine and Raney Nickel. *Tetrahedron Lett.* 1982, 23, 147–148.

(21) Billica, H. R.; Adkins, H. Catalyst, Raney Nickel, W-6. In *Organic Syntheses*; John Wiley & Sons: New York, NY, 1955; Collect. Vol. 3, p 176.

(22) Kafarski, P.; Lejezak, B. A Facile Conversion of Aminoalkane phosphonic Acids into Their Diethyl Esters. The Use of Unblocked Aminoalkane phosphonic Acids in Phosphono Peptide Synthesis. *Synthesis* 1988, 307–310.

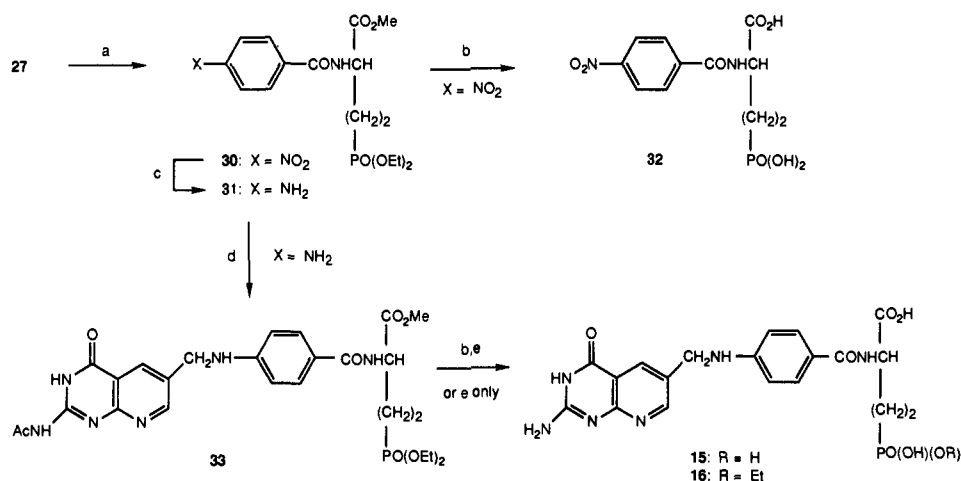
Scheme III<sup>a</sup>

<sup>a</sup> (a) 4-O<sub>2</sub>NC<sub>6</sub>H<sub>4</sub>COCl/Et<sub>3</sub>N; (b) Me<sub>3</sub>SiBr; (c) H<sub>2</sub>/Pd-C; (d) compd 21/BH<sub>3</sub>·Et<sub>3</sub>N/AcOH; (e) NaOH.

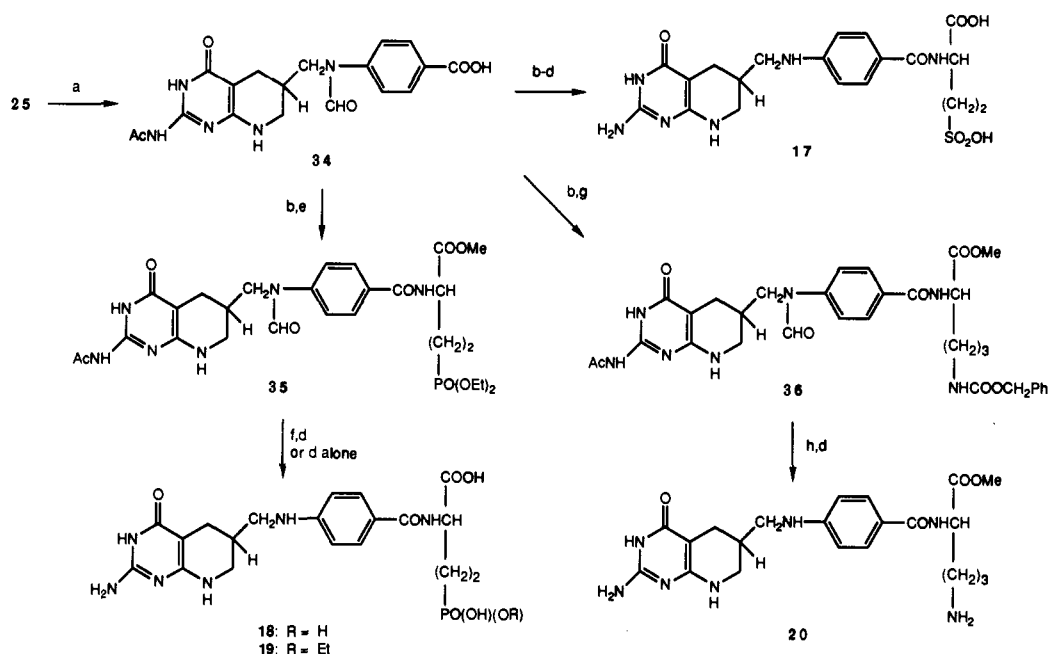
Scheme IV<sup>a</sup>

<sup>a</sup> (a) H<sub>2</sub>/Pt/CF<sub>3</sub>COOH; (b) *i*-BuOCOC1/Et<sub>3</sub>N; (c) H<sub>2</sub>NCH(COOMe)CH<sub>2</sub>CH<sub>2</sub>SO<sub>2</sub>OH; (d) NaOH; (e) H<sub>2</sub>NCH(COOMe)CH<sub>2</sub>CH<sub>2</sub>PO(OEt)<sub>2</sub> (27); (f) Me<sub>3</sub>SiBr; (g) H<sub>2</sub>NCH(COOMe)CH<sub>2</sub>CH<sub>2</sub>CH<sub>2</sub>NHCOCO<sub>2</sub>CH<sub>2</sub>Ph; (h) HBr/AcOH.

appropriately protected amino acids with the *N*<sup>2</sup>,*N*<sup>10</sup>-protected 5-deazatetrahydropteroic acid 34 by mixed anhydride chemistry. Compound 34, which had not been reported in the literature prior to this work, was prepared in 46% yield from 25 by catalytic hydrogenation (H<sub>2</sub>/Pt) in trifluoroacetic acid solution, and was purified by HPLC (C<sub>18</sub> silica gel, 5% MeCN in 0.05 M NH<sub>4</sub>OAc, pH 7.5). Mixed anhydride condensation (*i*-BuOCOC1/Et<sub>3</sub>N) of 34 with methyl L-homocysteate in DMF, followed directly by heating with NaOH (80 °C, 30 min) and purification by ion-exchange chromatography and HPLC (see above) yielded the target compound 5-dH<sub>4</sub>PteHCysA (17, 26%) as a hydrated ammonium salt. The methyl ester of L-homocysteic acid was superior to the bis(benzyltrimethylammonium) salt in this coupling reaction as compared with that of the nonreduced 5-deazapteroic acid 25.

Condensation of 34 with the blocked phosphonate ester 31 afforded the fully protected coupling product 35 (52%), which on deprotection by sequential treatment with Me<sub>3</sub>SiBr and NaOH was converted to the target diacid 5-dH<sub>4</sub>PteAPBA (18, 96%). As in the synthesis of 16, hy-

drolysis of 35 with NaOH alone left one ethyl ester group intact, giving ethyl 5-dH<sub>4</sub>PteAPBA (19, 50%). Addition of Et<sub>3</sub>N to the Me<sub>3</sub>SiBr reaction, which was also done in the reaction of 33, proved advantageous in that it produced a homogeneous reaction mixture. We had previously observed in similar Me<sub>3</sub>SiBr reactions where Et<sub>3</sub>N was omitted<sup>23</sup> that ester cleavage was incomplete due to precipitation of what appeared to be a mixture of HBr salts of the starting material and partially cleaved products. The HBr presumably arises by reaction of Me<sub>3</sub>SiBr with adventitious water, and is prevented from forming salts of incompletely cleaved products when Et<sub>3</sub>N is added approximately halfway through the reaction.

Mixed anhydride coupling of methyl *N*<sup>2</sup>-(benzyloxy-carbonyl)-L-ornithine with 34 afforded the fully protected

(23) Rosowsky, A.; Forsch, R. A.; Moran, R. G.; Kohler, W.; Freisheim, J. H. Methotrexate Analogues. 32. Chain Extension,  $\alpha$ -Carboxyl Deletion, and  $\gamma$ -Carboxyl Replacement by Sulfonate and Phosphonate: Effect on Enzyme Binding and Cell-Growth Inhibition. *J. Med. Chem.* 1988, 31, 1326-1331.

**Table I.** Inhibition of Mouse Liver Folylpolylglutamate Synthetase (FPGS) by 5-Deazafolate and 5-Deazatetrahydrofolate Analogues

compound	ring-B reduction	side-chain modification	$K_i$ , $\mu\text{M}^a$	pattern of inhibition
5-dPteHCysA (14)	No	SO <sub>2</sub> OH	570 (520, 615)	Noncompetitive
5-dH <sub>4</sub> PteHCysA (17)	Yes	SO <sub>2</sub> OH	22 (29, 16)	Noncompetitive
5-dPteAPBA (15)	No	PO(OH) <sub>2</sub>	9.0 (8.6, 9.4)	Competitive
5-dH <sub>4</sub> PteAPBA (18)	Yes	PO(OH) <sub>2</sub>	3.2 (2.6, 3.8)	Competitive
Et 5-dPteAPBA (16)	No	PO(OEt)(OH)	ca. 2000 <sup>b</sup>	ND
Et 5-dH <sub>4</sub> PteAPBA (19)	Yes	PO(OEt)(OH)	115 (94, 136)	Noncompetitive
5-dPteOrn (13)	No	CH <sub>2</sub> NH <sub>2</sub>	5.7 (4.4, 6.9)	Competitive
5-dH <sub>4</sub> PteOrn (20)	Yes	CH <sub>2</sub> NH <sub>2</sub>	0.030 (0.023, 0.035)	Competitive

<sup>a</sup> Assays were performed as previously described, using AMT as the variable substrates. The  $K_i$  values shown were derived from replots of the slopes of Lineweaver-Burk plots versus inhibitor concentration, and are the averages of two experiments on separate days (individual results given in parentheses). None of the compounds had detectable substrate activity at 500  $\mu\text{M}$ . 5-Deazatetrahydrofolate (DATHF) has been reported to have a  $K_m$  of  $1.06 \pm 0.06 \mu\text{M}$ .<sup>13a</sup> <sup>b</sup> Estimated from intersecting Dixon plots. ND = not determined.

adduct **36** (62%), which was converted directly to 5-dH<sub>4</sub>PteOrn (**20**, 81%) by sequential treatment with HBr/AcOH to remove the benzyloxycarbonyl group and with NaOH to cleave the methyl ester and deprotect N<sup>2</sup> and N<sup>10</sup>. The final product was obtained as a hydrated acetate salt after purification by preparative HPLC (C<sub>18</sub> silica gel, 5% EtOH-1% AcOH).

### Biological Activity

**FPGS Inhibition.** Previous work from our laboratories has established that folate analogues in which the terminal carboxyl group is replaced by either a phosphonic or sulfonic acid group are inhibitors of mouse liver FPGS,<sup>2,3</sup> and that the inhibitory potency of such analogues varies roughly in parallel with the  $K_m$  of the corresponding folate derivative as a substrate.<sup>6a,b,12,24</sup> DATHF is one of the best substrates for mammalian FPGS known, with a Michaelis constant ( $K_m$ ) of ca. 1  $\mu\text{M}$  for the mouse liver enzyme,<sup>13b</sup> and we therefore predicted that phosphonate and sulfonate analogues of 5-deazatetrahydrofolate would be good inhibitors. As shown in Table I, our expectation was at least partially realized, with the nonreduced phosphonate **15**, reduced sulfonate **17**, and reduced phosphonate **18** giving  $K_i$  values of 9.0, 22, and 3.2  $\mu\text{M}$ , respectively. However, the reduced monoethylphosphonate **19** was less active ( $K_i = 115 \mu\text{M}$ ), as were the nonreduced and reduced sulfonate and monoethyl phosphonate ( $K_i > 500 \mu\text{M}$ ). Striking differences were observed among the sulfonate and phosphonate analogues with respect to their kinetic patterns of FPGS inhibition (Table I and Figure 1). Thus, the phosphonates **15** and **18** were competitive inhibitors with AMT as the variable substrate, without any mixed component even at very high concentrations relative to their  $K_i$  values. On the other hand, the sulfonates were strict noncompetitive inhibitors versus variable AMT. The unexpected difference in pattern of inhibition between the phosphonates and sulfonates was consistent with the possibility that these two classes of analogues have an intrinsically different mode of binding to mouse liver FPGS. Interestingly, the noncompetitive binding of the sulfonate **14** contrasted with a previously reported finding that the corresponding analogue of AMT is a competitive inhibitor of FPGS from mouse<sup>2b,2c</sup> and human liver,<sup>4b</sup> suggesting that mode of binding may depend on the heteroaromatic ring system. While we cannot distinguish between these possibilities at this time, it is conceivable that compounds with 4-amino and 4-oxo substitution in the A-ring adopt different orientations when they bind to

FPGS, as they have been shown to do when they bind to DHFR.<sup>25</sup>

The phosphonate **18** ( $K_i = 3.2 \mu\text{M}$ ) was a somewhat more potent FPGS inhibitor than the corresponding AMT analogue ( $K_i = 8.4 \mu\text{M}$ ),<sup>2a</sup> which until then had been the best compound in the phosphonate series. Moreover, it should be noted that the  $K_i$  value given in Table I for **18** probably underestimates the binding affinity of this compound, because the material used for testing was synthesized by condensing (6*R*,6*S*)-5-deazatetrahydroptericoic acid with D,L-APBA, and was therefore a mixture of four stereoisomers. However, the stereochemistry at C-6 is unlikely to have much effect on FPGS binding, since the 6*S* and 6*R* diastereomers of tetrahydrofolate,<sup>8a,b</sup> 5-formyltetrahydrofolate,<sup>8b</sup> and DDATHF<sup>14b</sup> are all known to be substrates for FPGS and the  $K_m$  values of the individual diastereomers of DDATHF are approximately the same as the  $K_m$  of the mixture of isomers. Thus, only the stereochemistry of the APBA moiety is likely to affect binding. Assuming that the diastereomers with L-APBA and D-APBA side chains are present in equal amounts in the assayed sample, and that the diastereomer with the L-APBA side chain accounts for most of the observed activity, we would estimate the  $K_i$  of the active isomer to be in the 1-2  $\mu\text{M}$  range.

Although 5-dPteOrn (**13**) and 5-dH<sub>4</sub>PteOrn (**20**) were both competitive inhibitors of FPGS, the tetrahydro analogue was ca. 200-fold more active than the nonreduced compound. In contrast, reduction of the B-ring in N <sup>$\alpha$</sup> -pteroyl-L-ornithine has been reported to cause only a 30-fold increase in binding,<sup>8</sup> whereas reduction of the B-ring in **15**, the other competitive inhibitor in the present series, is virtually devoid of effect. This lack of a consistent pattern of change in binding constant of different classes of inhibitors with identical structural changes in seemingly distant parts of the molecule must indicate major differences in conformation of the protein bound to different classes of inhibitors. Compound **20** was a very potent inhibitor, with a  $K_i$  value of ca. 30 nM, and since there is good reason to think that the 6*S* diastereomer would be approximately twice as potent as the 6*R*,6*S* mixture used for testing, the  $K_i$  value for the 6*S* isomer of **20** may in fact be as low as 15 nM. Although **20** is still not as good an

(24) Rosowsky, A.; Forsch, R. A.; Moran, R. G. (6*R*,6*S*)-5,8,10-Trideaza-5,6,7,8-tetrahydrofolate and (6*R*,6*S*)-5,8,10-Trideaza-5,6,7,8-tetrahydropteroyl-L-ornithine as Potential Antifolates and Antitumor Agents. *J. Med. Chem.* 1989, 32, 709-715.

(25) (a) Oefner, C.; D'Arcy, A.; Winkler, F. K. Crystal Structure of Human Dihydrofolate Reductase Complexed with Folate. *Eur. J. Biochem.* 1988, 174, 377-385. (b) Davies, J. F.; Delcamp, T. J.; Prendergast, N. J.; Ashford, V. A.; Freisheim, J. H.; Kraut, J. Crystal Structures of Recombinant Human Dihydrofolate Reductase Complexed with Folate and 5-Deazafolate. *Biochemistry* 1990, 29, 9467-9479. (c) Stockman, B. J.; Nirmala, N. R.; Wagner, G.; Delcamp, T. J.; DeYarman, M. T.; Freisheim, J. H. Methotrexate Binds in a Non-Productive Orientation to Human Dihydrofolate Reductase in Solution, Based on NMR Spectroscopy. *FEBS Lett.* 1991, 283, 267-269.

**Table II.** Inhibition of Glycinamide Ribonucleotide Formyltransferase (GARFT), Dihydrofolate Reductase (DHFR), and Thymidylate Synthase (TS) by 5-Deazafofolate and 5-Deazatetrahydrofolate (DATHF) Analogues

compd	side-chain modification	ring-B reduction	enzyme inhibition		
			GARFT ( $K_i$ , $\mu\text{M}$ ) <sup>a</sup>	DHFR ( $\text{IC}_{50}$ , $\mu\text{M}$ ) <sup>b</sup>	TS ( $\text{IC}_{50}$ , $\mu\text{M}$ ) <sup>b</sup>
14	SO <sub>2</sub> OH	No	ND	0.4	55
15	PO(OH) <sub>2</sub>	No	ND	4.7	300
16	PO(OEt)(OH)	No	ND	1.3	100
17	SO <sub>2</sub> OH	Yes	0.19 (0.19, 0.20)	12	2100
18	PO(OH) <sub>2</sub>	Yes	0.047 (0.030, 0.064)	220	4200
19	PO(OEt)(OH)	Yes	ND	950	>5000
20	CH <sub>2</sub> NH <sub>2</sub>	Yes	3.7 (3.5, 4.0)	ND	ND

<sup>a</sup> Assays against GARFT from L1210 murine leukemia cells were carried out spectrophotometrically at 295 nm as previously described,<sup>13b</sup> using *N*<sup>10</sup>-formyl-5,8-dideazafofolate as the variable substrate. The  $K_i$  values listed were obtained from replots of the slopes of Lineweaver-Burk plots versus inhibitor concentrations, and are the averages of two experiments on separate days (individual values in parentheses). All the compounds tested were competitive with respect to the variable substrate. ND = not determined. The  $K_i$  of 5-deazatetrahydrofolate (DATHF) has been reported to be  $0.065 \pm 0.01 \mu\text{M}$ .<sup>13b</sup> <sup>b</sup> Assays against human DHFR (spectrophotometric) and human TS (tritium release from [5-<sup>3</sup>H]deoxyuridine) were performed in replicate as described previously.<sup>10b</sup> Results were averaged from several experiments with limits of variability of less than  $\pm 15\%$ . The  $\text{IC}_{50}$  of MTX against DHFR was  $0.0027 \mu\text{M}$ , and that of PDDF against TS was  $0.068 \mu\text{M}$ .

inhibitor as the 5-chloroquinazoline analogues 9 and 11, which are reported to have  $K_i$  values of 8.3 nM and 1.7 nM, respectively,<sup>10b</sup> it is the most potent FPGS inhibitor with a positively charged group on the end of the side chain that we have made to date.

The phosphonate monoethyl esters 16 and 19 were weak FPGS inhibitors and, like the sulfonates 14 and 17, inhibited the enzyme noncompetitively with aminopterin as the variable substrate. Hence, it appears that both the sulfonates and the monoesterified phosphonates may not be binding to FPGS at the same site as AMT. It was also remarkable, and unexpected, that reduction of the B-ring in 16 and 17 substantially increased activity even though these were noncompetitive inhibitors. Interestingly, the sulfonate and esterified phosphonate noncompetitive inhibitors in this series bear a single negative charge on the end of the side chain, whereas the ornithine and unesterified phosphonate competitive inhibitors bear a positive charge and two negative charges, respectively. The significance of this correlation is unclear at this time, and it remains to be determined whether the noncompetitive inhibition we observe with the sulfonates and monoesterified phosphonates is due to interaction with a second, possibly regulatory, site on the enzyme.

**GARTF Inhibition.** The DATHF analogues with APBA, HCysA, and Orn side chains were studied as inhibitors of GARFT isolated from mouse L1210 leukemia cells (Table II). All three compounds were competitive inhibitors of the transfer of a formyl group to glycinamide ribonucleotide from *N*<sup>10</sup>-formyl-5,8-dideazafofolate as the variable substrate. The phosphonate analogue 18 ( $K_i = 47 \text{ nM}$ ) was at least as active as the parent compound DATHF ( $K_i = 65 \text{ nM}$ ), whereas the sulfonate analogue 17 was 3-fold less active than DATHF and the ornithine analogue 20 was 57-fold less potent. We concluded from these results that the positive charge on the side chain of 20 interfered with binding, whereas the double negative charge on the shorter side chain of 18 was accepted by the active site and was somewhat better tolerated than the single negative charge on the side chain of 17. It has been shown in the 5,10-dideaza series that the diastereomer with the "natural" 6*R* configuration has a  $K_i$  of 29 nM and is roughly 2-fold more potent as a GARTF inhibitor than the racemate.<sup>13b</sup> Moreover, from what is known about the interaction of other antifolates with their target enzymes, it seems likely that the only diastereomer of 18 that will bind tightly to the active site of GARFT is the one with the L-APBA side chain. Thus, we estimate that this diastereomer has a  $K_i$  of ca. 10 nM against GARFT, which

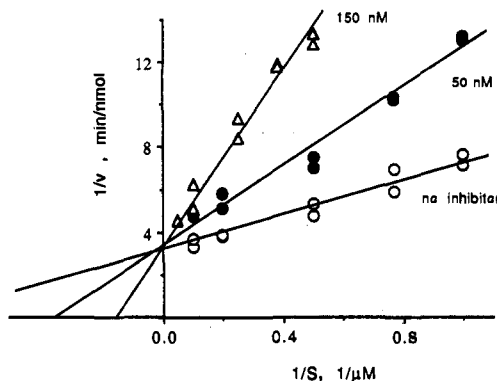

**Figure 2.** Inhibition of GARFT from L1210 mouse leukemia cells by reduced phosphonate 18. The rate of reaction was followed spectrophotometrically at 295 nm in the presence of the indicated concentrations of *N*<sup>10</sup>-formyl-5,8-dideazafofolate;<sup>13b</sup> the concentrations of 18 used are indicated above each line.

would make it about 3 times more potent than the 6*R* diastereomer of DDATHF. However, it is important to remember that, since polyglutamation is known to increase DDATHF binding to GARFT roughly 100-fold and the phosphonate analogue cannot form polyglutamates,<sup>13b</sup> one should not expect this analogue to be as potent as DDATHF or DATHF against intact cells even if uptake of the two drugs across the cell membrane were the same.

**Inhibition of Other Enzymes.** Given the general resemblance of compounds 14–16 to folic acid, we also compared their ability to inhibit dihydrofolate reductase (DHFR) to that of MTX and their ability to inhibit thymidylate synthase (TS) to that of *N*<sup>10</sup>-propargyl-5,8-dideazatetrahydrofolate (CB3717, PDDF). Likewise, the ability of the tetrahydro compounds 17–19 to inhibit these enzymes was determined. As shown in Table II, the most active compound against human DHFR was the nonreduced sulfonate 14, which had an  $\text{IC}_{50}$  of  $0.4 \mu\text{M}$  but was ca. 150-fold less potent than MTX ( $\text{IC}_{50} = 0.0027 \mu\text{M}$ ). The other nonreduced analogues 15 and 16 were several times less active than 14. The  $\text{IC}_{50}$  of 5-deazafofolate against DHFR from beef liver is reported to be  $0.8 \mu\text{M}$  as compared with  $0.005 \mu\text{M}$  for AMT.<sup>26</sup> Thus, replacement

(26) Taylor, E. C.; Palmer, D. C.; George, T. C.; Fletcher, S. R.; Tseng, C. P.; Harrington, P. J.; Dumas, D. J.; Beardsley, G. P. Synthesis and Biological Activity of L-5-Deazafofolate and L-5-Deazaaminopterin: Synthetic Strategies to 5-Deazapteridines. *J. Org. Chem.* 1983, 48, 4852–4860; see corrected list of authors in *J. Org. Chem.* 1984, 49, 3874.

of the  $\gamma$ -COOH group in 5-deazafolic acid by  $\text{SO}_2\text{OH}$  appears to appreciably diminish binding to mammalian DHFR. This is in general agreement with what has been observed previously with the  $\gamma$ -sulfonate analogues of MTX and AMT.<sup>2b</sup> The reduced sulfonate analogue 17 ( $\text{IC}_{50} = 12 \mu\text{M}$ ) was 30-fold less potent than its nonreduced counterpart, and the reduced phosphonates 18 and 19 were very poor inhibitors ( $\text{IC}_{50} > 200 \mu\text{M}$ ). The only compound with even a modicum of activity against TS was the non-reduced sulfonate 14 ( $\text{IC}_{50} = 55 \mu\text{M}$ ), whereas the  $\text{IC}_{50}$  values of the other nonreduced analogues were  $>100 \mu\text{M}$  and those of the reduced analogues were even higher. These results were not surprising, since both 5-deazafolate and its tetrahydro derivative are weak inhibitors of TS.<sup>16,27</sup> Given that the sulfonates and phosphonates reported here cannot form polyglutamates, it is safe to conclude that neither DHFR nor TS is a likely pharmacologic target for these compounds.

**Cell Growth Inhibition.** Compounds 14–19 were tested as cell growth inhibitors against WI-L2 and CEM human leukemic lymphoblasts as previously described,<sup>13a,28a,b</sup> and were found to be inactive at concentrations of up to  $100 \mu\text{M}$  (72-h treatment). Thus, despite their ability to bind well to FPGS and GARFT in cell-free assays, these compounds are much less active than 5-deazafolic acid ( $\text{IC}_{50} = 8.8 \mu\text{M}$  against L1210 cells)<sup>26</sup> or 5-deaza-5,6,7,8-tetrahydrofolic acid ( $\text{IC}_{50} = 0.01 \mu\text{M}$  against CEM cells)<sup>13a</sup> after the same exposure. We conclude from these results that inefficient cellular uptake and the inability to form polyglutamates are an obstacle to the use of these  $\gamma$ -modified 5-deazafolate analogues as therapeutic agents at this time.

### Experimental Section

IR spectra were obtained on a Perkin-Elmer Model 781 double-beam recording spectrophotometer; only peaks above  $1200 \text{ cm}^{-1}$  are reported. UV spectra were obtained on a Varian Model 210 instrument. <sup>1</sup>H-NMR spectra were obtained on a Varian EM3460L spectrometer with  $\text{Me}_4\text{Si}$  or  $\text{Me}_3\text{Si}(\text{CH}_2)_3\text{SO}_3\text{Na}$  as the reference. TLC analyses were done on fluorescent Eastman 13181 silica gel sheets or Eastman 13254 cellulose sheets. Spots were visualized under 254-nm UV illumination. Column chromatography was done on Baker 3405 (60–200 mesh) silica gel or Whatman DE-52 preswollen DEAE-cellulose. Solvents in moisture-sensitive reactions were dried over Linde 4A molecular sieves (Fisher, Boston, MA). HPLC was done on Waters  $\text{C}_{18}$  radial compression cartridges (analytical:  $5 \mu\text{m}$  particle size,  $5 \times 100 \text{ mm}$ ; preparative:  $15 \mu\text{m}$  particle size,  $25 \times 100 \text{ mm}$ ). Previously described methods were used to obtain methyl L-homocysteate,<sup>2b</sup> methyl *N*<sup>6</sup>-(benzyloxycarbonyl)-L-ornithinate,<sup>11</sup> and 2-acetamido-6-formylpyrido[2,3-*d*]pyrimidin-4(3*H*)-one (21).<sup>11,26</sup> Melting points were determined in Pyrex capillary tubes in a Mel-Temp apparatus (Cambridge Laboratory Devices, Cambridge, MA) and are not corrected. Microanalyses were performed by Quantitative Technologies, Inc., Bound Brook, NJ. Where samples isolated from column chromatography fractions by freeze-drying gave microanalytical data consistent with fractional ammonium salts (compounds 15, 17–19, 22, 25, 32, 34), it is likely that these were actually mixtures of the salt and free acid. Fractional ammonium

salts of freeze-dried folate analogues with sulfonic and phosphonic acid side chains have been described previously.<sup>2b,3a,3b</sup>

**(4-Nitrobenzoyl)-L-homocysteic Acid (22).** A suspension of L-homocysteic acid (183 mg, 1.0 mmol) in  $\text{CH}_2\text{Cl}_2$  (10 mL) was treated with  $\text{Et}_3\text{N}$  (417  $\mu\text{L}$ , 303 mg, 3.0 mmol) and  $\text{Me}_3\text{SiCl}$  (254  $\mu\text{L}$ , 217 mg, 2.0 mmol) and kept in an ultrasonic cleaning bath until a clear solution formed (5 min). 4-Nitrobenzoyl chloride (186 mg, 1.0 mmol) was then added in a single portion, and the mixture was stirred at room temperature for 10 min and quenched with  $\text{H}_2\text{O}$ . After allowing the product to undergo partition between the  $\text{CH}_2\text{Cl}_2$  and  $\text{H}_2\text{O}$  layers, the  $\text{CH}_2\text{Cl}_2$  layer was extracted with  $\text{H}_2\text{O}$ , the combined  $\text{H}_2\text{O}$  layers were adjusted to pH 7, and the product in the  $\text{H}_2\text{O}$  solution was purified by preparative HPLC using 0.01 M  $\text{NH}_4\text{OAc}$ , pH 6.7, as the eluent (no organic solvent). Pooled pure fractions were freeze-dried, and the residue was dried in vacuo ( $\text{P}_2\text{O}_5$ ,  $95^\circ\text{C}$ ) to obtain a brown glass which could be pulverized to an off-white powder (368 mg, 82%): mp  $58\text{--}61^\circ\text{C}$ ; analytical HPLC: 9.0 min (0.01 M  $\text{NH}_4\text{OAc}$ , pH 6.7, 1.5 mL/min); IR (KBr)  $\nu$  3450, 3060, 3000, 2950, 2820 sh, 2750, 2690, 2500, 1725 br, 1665, 1655, 1610, 1535, 1485, 1460, 1405, 1355, 1310, 1215  $\text{cm}^{-1}$ ; NMR ( $\text{D}_2\text{O}$ )  $\delta$  1.28 (t,  $J = 7 \text{ Hz}$ ,  $\text{NCH}_2\text{CH}_3$ ), 2.40 (m,  $\beta\text{-CH}_2$ ), 3.25 (m,  $\text{NCH}_2\text{CH}_3$  and  $\gamma\text{-CH}_2$ ), large peak at 4.7 ( $\text{H}_2\text{O}$ ), 8.00 (d,  $J = 8 \text{ Hz}$ , 2- and 6-aromatic protons), 8.40 (d,  $J = 9 \text{ Hz}$ , 3- and 5-aromatic protons). Anal. ( $\text{C}_{11}\text{H}_{12}\text{N}_2\text{O}_9\text{S}\cdot 0.5\text{NH}_3\cdot 0.5\text{H}_2\text{O}$ ) C, H, N.

***N*<sup>2</sup>-Acetyl-5-deazapteroic Acid (24).** A mixture of 21 (1.16 g, 0.005 mol) and 4-aminobenzoic acid (0.685 g, 0.005 mol) in glacial acetic acid (50 mL) was stirred at room temperature for 18 h, and  $\text{BH}_3\cdot\text{NEt}_3$  (0.288 g, 0.37 mL, 0.0025 mol) was added. After 1 h of additional stirring, the temperature was raised to  $60^\circ\text{C}$  for 30 min. The solution was poured slowly with stirring into  $\text{H}_2\text{O}$  (500 mL), and the mixture was chilled in an ice bath. The precipitate was collected, freeze-dried, and finally dried in vacuo ( $\text{P}_2\text{O}_5$ ,  $75^\circ\text{C}$ ) to obtain a pale-yellow powder (1.03 g, 55%): TLC:  $R_f$  0.3 (cellulose, pH 7.4 phosphate buffer); analytical HPLC retention time 7.5 min (0.1 M  $\text{NH}_4\text{OAc}$ , pH 7.5, 10% MeCN, 1.0 mL/min); mp  $>300^\circ\text{C}$ ; IR (KBr)  $\nu$  3450, 2940, 2030 br w, 1690, 1635, 1615, 1575, 1535, 1500, 1465, 1425, 1410, 1380, 1320, 1265  $\text{cm}^{-1}$ ; NMR ( $\text{CF}_3\text{CO}_2\text{H}$ )  $\delta$  1.97 (s,  $\text{CH}_3\text{CO}$ ), 4.63 (s,  $\text{C}_9\text{-CH}_2$ ), 7.22 (d,  $J = 8 \text{ Hz}$ ,  $\text{C}_3\text{-}$  and  $\text{C}_5\text{-H}$ ), 7.78 (d,  $J = 8 \text{ Hz}$ ,  $\text{C}_2\text{-}$  and  $\text{C}_6\text{-H}$ ), 8.73 (s,  $\text{C}_7\text{-H}$ ), 8.88 (s,  $\text{C}_7\text{-H}$ ). Anal. ( $\text{C}_{17}\text{H}_{15}\text{N}_5\text{O}_4\cdot\text{H}_2\text{O}$ ) C, H, N.

***N*<sup>2</sup>-Acetyl-*N*<sup>10</sup>-formyl-5-deazapteroic Acid (25).** A solution of 24 (1.16 g, 3.29 mol) in 95%  $\text{HCO}_2\text{H}$  (30 mL) was heated in an oil bath kept at  $80^\circ\text{C}$  for 1.5 h. The solvent was evaporated under reduced pressure, and the residue was dissolved in  $\text{H}_2\text{O}$  (50 mL) by adding just enough concentrated  $\text{NH}_4\text{OH}$  to form a clear solution. The solution was acidified with 10% AcOH and chilled in an ice bath, and the precipitate was collected and freeze-dried to obtain a pale-yellow solid (1.17 g, 93%) that was sufficiently pure for the next step. For microanalysis, a sample (0.1 g) of the product was chromatographed on a DEAE-cellulose column,  $\text{HCO}_3^-$  form,  $1.5 \times 22 \text{ cm}$ ) with 0.2 M  $\text{NH}_4\text{HCO}_3$  as the eluent. Pure fractions were pooled and freeze-dried to obtain colorless 25 as a partial ammonium salt; analytical HPLC retention time 7.2 min (0.05 M  $\text{NH}_4\text{OAc}$ , pH 7.5, 10% MeCN, 1.0 mL/min; preparative HPLC also possible using this system); mp  $>300^\circ\text{C}$ ; IR (KBr)  $\nu$  3440, 1680, 1635, 1610, 1575, 1520, 1505, 1465, 1405, 1390, 1360, 1270  $\text{cm}^{-1}$ ; NMR ( $\text{DMSO-}d_6$ )  $\delta$  2.17 (s,  $\text{CH}_3\text{CO}$ ), 5.18 (s,  $\text{C}_9\text{-CH}_2$ ), 7.43 (d,  $J = 8 \text{ Hz}$ ,  $\text{C}_3\text{-}$  and  $\text{C}_5\text{-H}$ ), 8.72 (s,  $J = 8 \text{ Hz}$ ,  $\text{C}_2\text{-}$  and  $\text{C}_6\text{-H}$ ). Anal. ( $\text{C}_{18}\text{H}_{15}\text{N}_5\text{O}_5\cdot 0.25\text{NH}_3\cdot 1.25\text{H}_2\text{O}$ ) C, H, N.

***N*-(5-Deazapteroyl)-L-homocysteic Acid (5-dPteHCysA, 14).** A solution of L-homocysteic acid (183 mg, 1.0 mmol) in  $\text{H}_2\text{O}$  (20 mL) was stirred during dropwise addition of a 40% solution of benzyltrimethylammonium methoxide in MeOH to pH 11. The MeOH was removed by rotary evaporation, and the remaining solution was freeze-dried to obtain a gum which was taken up in DMF (5 mL). The resulting solution, calculated to contain 0.2 mmol/mL of bis(benzyltrimethylammonium) L-homocysteate, was used directly in the next step.

A solution of 25 (114 mg, 0.3 mmol) in DMF (10 mL) was treated with  $\text{Et}_3\text{N}$  (46  $\mu\text{L}$ , 33 mg, 0.33 mmol) and *i*-BuOCOCl (43  $\mu\text{L}$ , 45 mg, 0.33 mmol) and stirred at room temperature for 5 min. To this solution was then added 1.5 mL (0.3 mmol) of the solution of bis(benzyltrimethylammonium) L-homocysteate prepared above. The solvent was evaporated, and the residue was dissolved in 0.5 N NaOH (10 mL) and heated under  $\text{N}_2$  at  $80^\circ\text{C}$  for 30 min.

(27) Piper, J. R.; McCaleb, G. S.; Montgomery, J. A.; Kisliuk, R. L.; Gaumont, Y.; Sirotnak, F. M. Syntheses and Antifolate Activity of 5-Methyl-5-deaza Analogues of Aminopterin, Methotrexate, Folic Acid, and *N*<sup>10</sup>-Methylfolic Acid. *J. Med. Chem.* 1986, 29, 1080–1087.

(28) Rosowsky, A.; Bader, H.; Cucchi, C. A.; Moran, R. G.; Kohler, W.; Freisheim, J. H. Methotrexate Analogues. 33. *N*<sup>2</sup>-Acyl-*N*<sup>6</sup>-(4-amino-4-deoxypteroyl)-L-ornithine Derivatives: Synthesis and In Vitro Antitumor Activity. *J. Med. Chem.* 1988, 31, 1332–1337. (b) Rosowsky, A.; Forsch, R. A.; Moran, R. G.; Freisheim, J. H. Synthesis and Biological Activity of the 2-Desamino and 2-Desamino-2-methyl Analogues of Aminopterin and Methotrexate. *J. Med. Chem.* 1991, 34, 227–234.



The cooled solution was adjusted to pH 7 with HCl and purified by preparative HPLC (3% MeCN in 0.05 M  $\text{NH}_4\text{OAc}$ , pH 6.7). Pooled pure fractions were concentrated by rotary evaporation to remove the MeCN and were then freeze-dried to obtain a product whose  $^1\text{H-NMR}$  spectrum as well as elemental analysis still revealed it to be a partial benzyltrimethylammonium salt. To convert the product to an ammonium salt, it was taken up in  $\text{H}_2\text{O}$  and applied onto a DEAE-cellulose column (16 g,  $1.5 \times 20$  cm,  $\text{HCO}_3^-$  form). The column was eluted first with a large volume of  $\text{H}_2\text{O}$  and then with 500 mL of 0.4 M  $\text{NH}_4\text{HCO}_3$ . Pooled fractions were freeze-dried and repurified by preparative HPLC as described above to obtain a light-yellow solid (45 mg, 27%); analytical HPLC retention time 9.0 min (3% MeCN in 0.05 M  $\text{NH}_4\text{OAc}$ , pH 6.7, 2.0 mL/min); IR (KBr)  $\nu$  3430, 2870, 2800 sh, 1700 sh, 1675, 1650 sh, 1615, 1580, 1525, 1450, 1410, 1340–1320, 1275, 1205  $\text{cm}^{-1}$ ; UV  $\lambda_{\text{max}}$  (0.1 M HCl) 214 nm ( $\epsilon$  36900), 247 (12400), 280 (23000), 295 inf (19900), 350 (7400);  $\lambda_{\text{max}}$  (pH 7.4 phosphate buffer) 215 nm ( $\epsilon$  40100), 277 (24500), 293 (23900);  $\lambda_{\text{max}}$  (0.1 M NaOH) 218 nm ( $\epsilon$  33300), 242 (23400), 279 (23600), 290 sh (23100), 336 inf (9100);  $^1\text{H-NMR}$  ( $\text{D}_2\text{O} + \text{Na}_2\text{CO}_3$ )  $\delta$  2.27 (m,  $\beta$ - $\text{CH}_2$ ), 3.03 (m,  $\gamma$ - $\text{CH}_2$ ), 4.7 (large  $\text{H}_2\text{O}$  peak), 6.77 (d,  $J = 8$  Hz,  $\text{C}_3$ - and  $\text{C}_6$ -H), 7.67 (d,  $J = 8$  Hz,  $\text{C}_2$ - and  $\text{C}_6$ -H). Anal. ( $\text{C}_{16}\text{H}_{20}\text{N}_6\text{O}_7\text{S}\cdot\text{NH}_3\cdot 3\text{H}_2\text{O}$ ) C, H, N, S.

**Methyl D,L-2-Amino-4-(diethoxyphosphinyl)butanoate (27).** Method A. A suspension of D,L-2-amino-4-phosphonobutanoic acid (1.83 g, 0.01 mol) in  $\text{HC}(\text{OEt})_3$  (40 mL) was heated under reflux for 6 days, with the condenser being removed occasionally to allow volatiles to escape. The solid partially dissolved during this time. When the reaction was complete the solvent was evaporated under reduced pressure and the resulting gummy residue, consisting of a mixture of ethyl D,L-2-formamido-4-(diethoxyphosphinyl)butanoate (26) and other products according to the  $^1\text{H-NMR}$  spectrum, was treated first with HCl-saturated MeOH (35 mL) in an ice bath and then dropwise with  $\text{SOCl}_2$  (3 mL). After 18 h at room temperature the reaction mixture was evaporated to dryness under reduced pressure, the residue was dissolved in  $\text{CHCl}_3$  (50 mL), and the solution was stirred for 30 min with anhydrous  $\text{Na}_2\text{CO}_3$  (10.6 g). The solid was filtered, the filtrate was evaporated under reduced pressure, the residue was dissolved in  $\text{Et}_2\text{O}$  (15 mL), and the solution was poured slowly into a vigorously stirred solution of anhydrous oxalic acid (0.9 g, 0.01 mol) in  $\text{Et}_2\text{O}$  (35 mL). After overnight refrigeration, the liquid was decanted and the gummy residue recrystallized from MeOH-EtOAc. Drying in vacuo ( $\text{P}_2\text{O}_5$ , 60 °C) yielded 0.87 g (25%) of a white powder whose microanalysis showed it to be the sesquioxalate salt of the methyl ester 27: mp 134–135 °C; IR (KBr)  $\nu$  3460, 2990, 2970, 2940, 1890–1830 sh, 1755, 1705, 1670, 1645, 1530, 1490, 1450, 11410, 1345, 1330, 1300, 1285, 1225  $\text{cm}^{-1}$ ; NMR ( $\text{DMSO}-d_6$ )  $\delta$  1.23 (t,  $J = 7$  Hz, 2  $\text{CH}_2\text{CH}_3$ ), 1.98 (m,  $\beta$ - and  $\gamma$ - $\text{CH}_2$ ), 3.75 (s,  $\text{OCH}_3$ ), 4.00 (q,  $J = 7$  Hz, 2  $\text{CH}_2\text{CH}_3$ ), 4.25 (m,  $\alpha$ -CH), 7.33 (s, exchangeable with  $\text{D}_2\text{O}$ ,  $\text{NH}_2$ , and  $\text{COOH}$ ). Anal. ( $\text{C}_9\text{H}_{20}\text{NO}_5\text{P}\cdot 1.5\text{C}_2\text{H}_2\text{O}_4$ ) C, H, N, P.

**Method B.** A suspension of D,L-2-amino-4-phosphonobutanoic acid (3.66 g, 0.02 mol) in absolute MeOH (100 mL) was cooled in an ice-bath while  $\text{SOCl}_2$  (20 mL) was added dropwise with stirring so that the internal temperature did not exceed 12 °C. The solution was left at room temperature overnight and then evaporated under reduced pressure to obtain methyl D,L-2-amino-4-phosphonobutanoate hydrochloride (28-HCl) as a gum. The product was taken up directly in  $\text{HC}(\text{OEt})_3$  (80 mL), and the solution was heated under reflux for 3 h with occasional removal of the condenser to release volatiles. The solvent was then evaporated and the residue, consisting of methyl D,L-2-formamido-4-(diethoxyphosphinyl)butanoate (29), was taken up in HCl-saturated MeOH (70 mL), and  $\text{SOCl}_2$  (1 mL) was added to ensure that deformylation would not be accompanied by cleavage of the methyl ester. The reaction mixture was left to stand at room temperature for 18 h and then evaporated to dryness under reduced pressure. Drying of the residue in vacuo ( $\text{P}_2\text{O}_5$ , 60 °C) yielded 26-HCl as a gum pure enough to use directly in the next step.

**Methyl D,L-2-[(4-Nitrobenzoyl)amino]-4-(diethoxyphosphinyl)butanoate (30).** Compound 27-HCl was dissolved in  $\text{CH}_2\text{Cl}_2$  (100 mL), and to the solution was added  $\text{Et}_3\text{N}$  (5.05 g, 6.96 mL, 0.05 mol) followed by 4-nitrobenzoyl chloride. After quenching of the acylation with excess MeOH, the solution was

washed with  $\text{H}_2\text{O}$  and evaporated under reduced pressure. The residue was chromatographed on a silica gel column (80 g,  $3 \times 37$  cm) which was eluted first with  $\text{CHCl}_3$  to remove methyl 4-nitrobenzoate and a red impurity and then with 19:1  $\text{CHCl}_3$ -MeOH. TLC-pure fractions ( $R_f$  0.3, silica gel,  $\text{CHCl}_3$ ) were evaporated, and the residue was dried in vacuo ( $\text{P}_2\text{O}_5$ , 60 °C) to obtain a yellow solid (2.4 g, 30%): double mp 90–93 °C, 99–103 °C; IR (KBr)  $\nu$  3440, 3310, 3120, 3090, 3060, 3000, 2970, 2950, 2920, 2880, 1940 br w, 1750, 1675, 1610, 1565, 1535, 1495, 1455, 1400, 1355, 1370, 1245, 1225  $\text{cm}^{-1}$ ; NMR ( $\text{CDCl}_3$ )  $\delta$  1.32 (dt,  $J = 7$  Hz,  $J = 2$  Hz, 2  $\text{CH}_2\text{CH}_3$ ), 1.55–2.60 (m,  $\beta$ - and  $\gamma$ - $\text{CH}_2$ ), 3.77 (s,  $\text{OMe}$ ), 4.05 (m, 2  $\text{CH}_2\text{CH}_3$ ), 4.75 (m,  $\alpha$ -CH), 8.20 (m, aryl, NH). Anal. ( $\text{C}_{16}\text{H}_{23}\text{N}_2\text{O}_8\text{P}$ ) C, H, N.

**Methyl D,L-2-[(4-Aminobenzoyl)amino]-4-(diethoxyphosphinyl)butanoate (31).** A solution of 30 (201 mg, 0.5 mmol) in MeOH (20 mL) was shaken with 5% Pd-C (20 mg) in a low-pressure Parr apparatus under 3 atm of  $\text{H}_2$  for 20 h. The catalyst was filtered, and the filtrate was evaporated to obtain a light-orange solid (183 mg, 98%): mp 165–167 °C;  $R_f$  0.6 (silica gel, 19:1  $\text{CHCl}_3$ -MeOH); IR (KBr)  $\nu$  3420, 3360, 3250, 30380, 2990, 2960, 2940, 1755, 1660, 1630, 1615, 1570, 1550, 1520, 1455, 1440, 1410, 1395, 1365, 1325, 1275, 1245, 1215  $\text{cm}^{-1}$ ; NMR ( $\text{DMSO}-d_6$ )  $\delta$  1.20 (t,  $J = 7$  Hz, 2  $\text{CH}_2\text{CH}_3$ ), 1.55–2.30 (m,  $\beta$ - and  $\gamma$ - $\text{CH}_2$ ), 3.60 (s,  $\text{OCH}_3$ ), 3.97 (q,  $J = 7$  Hz, 2  $\text{CH}_2\text{CH}_3$ ), 4.50 (m,  $\alpha$ -CH), 5.60 (br s,  $\text{NH}_2$ ), 6.52 (d,  $J = 8$  Hz,  $\text{C}_3$ - and  $\text{C}_6$ -H), 7.60 (d,  $J = 8$  Hz,  $\text{C}_2$ - and  $\text{C}_6$ -H), 8.28 (d,  $J = 7$  Hz, NH). Anal. ( $\text{C}_{16}\text{H}_{25}\text{N}_2\text{O}_8\text{P}$ ) C, H, N.

**D,L-2-[(4-Nitrobenzoyl)amino]-4-phosphonobutanoic Acid (32).** Compound 30 (402 mg, 1.0 mmol) was dissolved in a mixture of  $\text{CH}_2\text{Cl}_2$  (1 mL) and  $\text{Me}_3\text{SiBr}$  (4.59 g, 3.96 mL, 30 mmol), and the solution was left at room temperature for 20 h and then evaporated to dryness. The residue was taken up in 1 M NaOH (20 mL), and after 5 min the solution was adjusted to pH 7 with HCl and washed with  $\text{Et}_2\text{O}$ . The aqueous phase was subjected to preparative HPLC on  $\text{C}_{18}$ -silica gel (0.05 M  $\text{NH}_4\text{OAc}$ , pH 6.7, 2.5% MeCN). Pooled pure fractions (analytical retention time 5 min; 0.05 M  $\text{NH}_4\text{OAc}$ , pH 6.7, 5% MeCN) were freeze-dried, and then dried in vacuo ( $\text{P}_2\text{O}_5$ , 90 °C) to obtain an off-white solid (265 mg, 70%): mp 176–178 °C (with softening); IR (KBr)  $\nu$  3430, 3120, 3080, 2970, 2940, 2890, 2870, 1720, 1655, 1605, 1435, 1495, 1455, 1410, 1355, 1325, 1310  $\text{cm}^{-1}$ . Anal. ( $\text{C}_{11}\text{H}_{13}\text{N}_2\text{O}_8\text{P}\cdot 1.5\text{NH}_3\cdot \text{H}_2\text{O}$ ) C, H, N.

**Methyl D,L-2-[(N<sup>2</sup>-Acetyl-5-deazapteroyl)amino]-4-(diethoxyphosphinyl)butanoate (33).** A solution of 31 (372 mg, 1.0 mmol) and 21 (232 mg, 1.0 mmol) in glacial AcOH (3 mL) was stirred at room temperature for 17 h and then treated with  $\text{BH}_3\cdot\text{NEt}_3$  (58 mg, 74  $\mu\text{L}$ , 0.5 mmol). Stirring was continued at room temperature for 2.5 h and at 65 °C (bath temperature) for 20 min. The solvent was evaporated, and the residue was purified by chromatography on a silica gel column (40 g,  $2.5 \times 35$  cm, 19:1  $\text{CHCl}_3$ -MeOH). Fractions homogeneous by TLC ( $R_f$  0.4, silica gel, 19:1  $\text{CHCl}_3$ -MeOH) were pooled and concentrated to a small volume, and hexane was added until a precipitate formed. The solid was collected and dried in vacuo ( $\text{P}_2\text{O}_5$ , 60 °C) to obtain an off-white solid (195 mg, 33%): mp 123–128 °C; IR (KBr)  $\nu$  3450, 2990, 2970, 2940, 1740, 1685, 1640, 1615, 1580, 1525, 1485, 1470, 1410, 1380, 1320, 1270, 1245, 1205  $\text{cm}^{-1}$ ; NMR ( $\text{CDCl}_3$ )  $\delta$  1.32 (t,  $J = 7$  Hz, 2  $\text{CH}_2\text{CH}_3$ ), 1.73 (m,  $\beta$ - $\text{CH}_2$ ), 2.08 (m,  $\gamma$ - $\text{CH}_2$ ), 2.43 (s,  $\text{CH}_3\text{CO}$ ), 3.25 (m, NH), 3.73 (s,  $\text{OMe}$ ), 4.08 (m, 2  $\text{CH}_2\text{CH}_3$ ), 4.45 (m,  $\text{C}_6$ - $\text{CH}_2$ ), 4.95 (br m,  $\alpha$ -CH and 2 NH), 6.55 (d,  $J = 8$  Hz,  $\text{C}_3$ - and  $\text{C}_6$ -H), 7.70 (d,  $J = 8$  Hz,  $\text{C}_2$ - and  $\text{C}_6$ -H), 8.43 (m,  $\text{C}_5$ -H), 8.90 (m,  $\text{C}_7$ -H). Anal. ( $\text{C}_{26}\text{H}_{33}\text{N}_6\text{O}_8\text{P}\cdot 0.25\text{H}_2\text{O}$ ) C, H, N.

**D,L-2-[(5-Deazapteroyl)amino]-4-phosphonobutanoic Acid (5-dPteAPBA, 15).** Ester 33 (60 mg, 0.1 mmol) was treated with  $\text{Me}_3\text{SiBr}$  (1.53 g, 1.32 mL) in  $\text{CH}_2\text{Cl}_2$  (5 mL) at room temperature for 45 min. The mixture remained cloudy, but immediately became clear on addition of  $\text{Et}_3\text{N}$  (50 mg, 60  $\mu\text{L}$ , 0.5 mmol). After another 3 days at room temperature, the solution was evaporated, and the residue was dissolved in  $\text{H}_2\text{O}$  (3 mL). The solution was adjusted to pH 12 by dropwise addition of 2 N NaOH, and a further 5 mL of 1 N NaOH was added. The solution was heated under  $\text{N}_2$  at 80 °C for 30 min, cooled, adjusted to pH 7 with HCl, and subjected to preparative HPLC on  $\text{C}_{18}$  silica gel (analytical retention time 4.0 min; 0.05 M  $\text{NH}_4\text{OAc}$ , pH 6.7, 5% MeCN, 1.5 mL/min). Pooled pure fractions were concentrated to dryness under reduced pressure, and the residue was freeze-dried to obtain

a light-yellow solid (35 mg, 73%): mp >300 °C; IR (KBr)  $\nu$  3460, 1710 sh, 1675, 1650, 1620, 1580, 1550, 1525, 1465, 1455, 1410, 1325, 1275, 1200  $\text{cm}^{-1}$ ; UV  $\lambda_{\text{max}}$  (0.1 M HCl) 214 nm ( $\epsilon$  36,300), 247 (12,000), 280 (23,300), 293 infl (23,300), 350 (7,100);  $\lambda_{\text{max}}$  (pH 7.4 buffer) 215 nm ( $\epsilon$  41,200), 277 (24,800), 291 sh (23,700);  $\lambda_{\text{max}}$  (0.1 M NaOH) 218 ( $\epsilon$  33,400), 242 (23,200), 278 (24,400), 288 infl (23,400), 335 infl (9,000); NMR ( $\text{D}_2\text{O} + \text{Na}_2\text{CO}_3$ )  $\delta$  1.90 (m,  $\beta$ - and  $\gamma$ - $\text{CH}_2$ ), 4.35 (m,  $\text{C}_6$ - $\text{CH}_2$ ,  $\alpha$ -CH), 6.68 (d,  $J = 8$  Hz,  $\text{C}_3$ - and  $\text{C}_5$ -H), 7.62 (d,  $J = 8$  Hz,  $\text{C}_2$ - and  $\text{C}_6$ -H), 8.23 (m,  $\text{C}_5$ -H), 8.53 (m,  $\text{C}_7$ -H). Preparative HPLC had to be carried out twice to obtain the analytical sample. Anal. ( $\text{C}_{19}\text{H}_{21}\text{N}_6\text{O}_7\text{P} \cdot 1.25\text{NH}_3 \cdot 3.5\text{H}_2\text{O}$ ) C, H, N.

**D,L-2-[(5-Deazapteroyl)amino]-4-(ethoxyhydroxyphosphinyl)butanoic Acid (Ethyl 5-dPteAPBA, 16).** A solution of ester **33** (58 mg, 0.1 mmol) in 1 N NaOH (5 mL) under  $\text{N}_2$  was heated at 85 °C (oil bath temp) for 30 min, then cooled, diluted to 40 mL, and adjusted to pH 7 with HCl. The product was purified by preparative HPLC on  $\text{C}_{18}$  silica gel (analytical retention time 9.0 min; 0.05 M  $\text{NH}_4\text{OAc}$ , pH 6.7, 5% MeCN, 1.5 mL/min). Pure fractions were pooled and concentrated to dryness under reduced pressure, and the residue was freeze-dried to obtain a pale-yellow solid (29 mg, 58%): mp >300 °C; IR (KBr)  $\nu$  3470, 1720, 1675, 1655, 1620, 1580, 1525, 1455, 1410, 1325, 1270, 1240, 1200  $\text{cm}^{-1}$ ; NMR ( $\text{DMSO}-d_6$ )  $\delta$  1.15 (t,  $J = 7$  Hz,  $\text{CH}_2\text{CH}_3$ ), 1.72 (m,  $\beta$ - and  $\gamma$ - $\text{CH}_2$ ), 3.75 (m,  $\text{CH}_2\text{CH}_3$ , partly obscured by a large  $\text{H}_2\text{O}$  peak), 6.67 (d,  $J = 8$  Hz,  $\text{C}_3$ - and  $\text{C}_5$ -H), 7.67 (d,  $J = 8$  Hz,  $\text{C}_2$ - and  $\text{C}_6$ -H), 8.27 (m,  $\text{C}_5$ -H,  $\text{C}_7$ -H). Anal. ( $\text{C}_{21}\text{H}_{25}\text{N}_6\text{O}_7\text{P} \cdot \text{NH}_3 \cdot 3\text{H}_2\text{O}$ ) C, H, N.

**$\text{N}^2$ -Acetyl- $\text{N}^{10}$ -formyl-5,6,7,8-tetrahydro-5-deazapteroic Acid (34).** A solution of **25** (201 mg, 0.493 mmol) in  $\text{CF}_3\text{CO}_2\text{H}$  (10 mL) was shaken with  $\text{PtO}_2 \cdot \text{H}_2\text{O}$  (20 mg) in a Parr low-pressure apparatus under 3 atm of  $\text{H}_2$  for 18 h. The catalyst was removed, the solvent was evaporated, and the residue was taken up in 5%  $\text{NH}_4\text{OH}$  (50 mL) with the aid of an ultrasonication bath. A small amount of insoluble material was removed by filtration, and the filtrate was adjusted to pH 7 with AcOH. An additional small amount of fine precipitate gradually formed and was removed by filtration, and the filtrate was subjected to preparative HPLC on  $\text{C}_{18}$  silica gel (analytical retention time 11.0 min; 0.05 M  $\text{NH}_4\text{OAc}$ , pH 7.5, 5% MeCN, 1 mL/min). Pooled pure fractions were concentrated to dryness on a rotary evaporator, and the residue was freeze-dried to obtain a partial ammonium salt of **34** as a white powder (96 mg, 46%): mp >300 °C; IR (KBr)  $\nu$  3460, 1660, 1610, 1585, 1560, 1520, 1485, 1470, 1445 w, 1315, 1275, 1215  $\text{cm}^{-1}$ ; NMR ( $\text{DMSO}-d_6 + \text{D}_2\text{O}$ )  $\delta$  1.85 (m,  $\text{C}_6$ -CH), 2.08 (s,  $\text{CH}_3\text{CO}$ ), 2.98 (m, 5- $\text{CH}_2$ ), 3.7 ( $\text{C}_6$ - $\text{CH}_2$ , partially obscured by large  $\text{H}_2\text{O}$  peak), 7.48 (d,  $J = 8$  Hz,  $\text{C}_3$ - and  $\text{C}_5$ -H), 7.98 (d,  $J = 8$  Hz,  $\text{C}_2$ - and  $\text{C}_6$ -H), 8.63 (s,  $\text{N}^{10}$ -CHO). Anal. ( $\text{C}_{18}\text{H}_{19}\text{N}_6\text{O}_5 \cdot 0.2\text{NH}_3 \cdot 2\text{H}_2\text{O}$ ) C, H, N.

**$\text{N}^2$ -(5,6,7,8-Tetrahydro-5-deazapteroyl)-L-homocysteic Acid (5-dH<sub>4</sub>PteHCysA, 17).** A stirred solution of **34** (85 mg, 0.2 mmol) in dry DMF (4 mL) was treated with  $\text{Et}_3\text{N}$  (24 mg, 33  $\mu\text{L}$ , 0.24 mmol) and *i*-BuOCOC1 (33 mg, 31  $\mu\text{L}$ , 0.24 mmol). After 5 min at room temperature, the mixed anhydride solution was treated with 2 mL of a 0.1 M solution of methyl L-homocysteate in DMF, along with a second portion of  $\text{Et}_3\text{N}$  (40 mg, 55  $\mu\text{L}$ , 0.4 mmol). After two more cycles of addition of  $\text{Et}_3\text{N}$  (10 mg, 14  $\mu\text{L}$ , 0.1 mmol), *i*-BuOCOC1 (14 mg, 13  $\mu\text{L}$ , 0.1 mmol), and the amino acid ester (1 mL of 0.1 M solution, 0.1 mmol), the solvent was evaporated under reduced pressure. The residue was heated at 80 °C for 30 min in 0.5 M NaOH (10 mL), and the solution was cooled and adjusted to pH 7 with concentrated HCl. Analytical HPLC ( $\text{C}_{18}$  silica gel, 3% MeCN in 0.05 M  $\text{NH}_4\text{OAc}$ , pH 6.9, flow rate 1.0 mL/min) showed the product as a peak with a retention time of 11.5 min. Preparative HPLC in this system followed by a workup similar to that of **14** afforded a white solid (82 mg) whose elemental analysis indicated that a UV-transparent impurity had probably coeluted with the product. The impure product was therefore purified further by ion-exchange chromatography on DEAE-cellulose ( $\text{HCO}_3^-$  form,  $1.5 \times 26$  cm) by successive elution with  $\text{H}_2\text{O}$ , 0.2 M  $\text{NH}_4\text{HCO}_3$ , and 0.4 M  $\text{NH}_4\text{HCO}_3$ . The UV-absorbing fractions were pooled and freeze-dried to obtain an analytically pure white solid (27 mg, 26%): mp >300 °C; IR (KBr)  $\nu$  3420, 2920, 1650, 1600, 1545, 1500, 1480, 1460, 1445, 1395, 1355, 1300, 1265  $\text{cm}^{-1}$ ; UV  $\lambda_{\text{max}}$  (0.1 M HCl) 202 nm ( $\epsilon$  35,100), 275 (24,500);  $\lambda_{\text{max}}$  (pH 7.4 phosphate buffer) 203 ( $\epsilon$  32,300), 214 sh

(30,000), 273 (21,200);  $\lambda_{\text{max}}$  (0.1 M NaOH) 216 nm ( $\epsilon$  26,700), 268 (19,900). Anal. ( $\text{C}_{19}\text{H}_{24}\text{N}_6\text{O}_7\text{S} \cdot 0.8\text{NH}_3 \cdot 2\text{H}_2\text{O}$ ) C, H, N, S.

**Methyl D,L-[( $\text{N}^2$ -Acetyl- $\text{N}^{10}$ -formyl-5,6,7,8-tetrahydro-5-deazapteroyl)amino]-4-(diethoxyphosphinyl)butanoate (35).** A solution of **34** (74 mg, 0.17 mmol) in dry DMF (40 mL) was treated with  $\text{Et}_3\text{N}$  (20 mg, 28  $\mu\text{L}$ , 0.2 mmol) and *i*-BuOCOC1 (27 mg, 26  $\mu\text{L}$ , 0.2 mmol) and stirred at room temperature for 5 min. A mixture of 27-HCl (116 mg, 0.3 mmol) and  $\text{Na}_2\text{CO}_3$  (106 mg, 1 mmol) in dry DMF (3 mL) was stirred for 30 min in a separate flask, and 2 mL of this solution of **27** was added to the mixed anhydride in the flask. A second cycle of coupling was carried out using 0.1 mmol each of the  $\text{Et}_3\text{N}$  and *i*-BuOCOC1 and the balance of the solution of **27**. The solvent was evaporated, and the residue was purified by column chromatography on silica gel (12 g,  $5 \times 20$  cm) with 9:1  $\text{CHCl}_3$ -MeOH as the eluent. The fractions containing **35** ( $R_f$  0.5) were concentrated,  $\text{Et}_2\text{O}$  was added, and the solid was collected and dried in vacuo ( $\text{P}_2\text{O}_5$ , 60 °C) to obtain a white solid (59 mg, 52%): double mp 123–135 °C, 176–180 °C; IR (KBr)  $\nu$  3440, 2990, 2940, 1745, 1655, 1615, 1585, 1555, 1510, 1485, 1470, 1450, 1400, 1390, 1375, 1345, 1310, 1270, 1250  $\text{cm}^{-1}$ . Anal. ( $\text{C}_{27}\text{H}_{37}\text{N}_6\text{O}_9\text{P} \cdot 1.5\text{H}_2\text{O}$ ) C, H, N.

When the coupling reaction was carried out by addition of solid 27-HCl and  $\text{Et}_3\text{N}$  to the mixed anhydride solution, the yield of **35** was only 25%.

**D,L-2-[(5,6,7,8-Tetrahydro-5-deazapteroyl)amino]-4-phosphonobutanoic Acid (5-dH<sub>4</sub>PteAPBA, 18).** A solution of **35** (58 mg, 0.087 mmol) in  $\text{CH}_2\text{Cl}_2$  (3 mL) was treated with  $\text{Me}_2\text{SiBr}$  (1.22 g, 1.06 mL, 8.0 mmol). A heavy precipitate formed, which dissolved on addition of  $\text{Et}_3\text{N}$  (22 mg, 30  $\mu\text{L}$ , 0.22 mmol). The solution was allowed to stand at room temperature for 4 days and then evaporated under reduced pressure. The residue was dissolved in 1 N NaOH (5 mL), and the solution was heated at 80 °C for 30 min, cooled, and adjusted to pH 7 with concentrated HCl. Analytical HPLC ( $\text{C}_{18}$  silica gel, 3% MeCN in 0.05 M  $\text{NH}_4\text{OAc}$ , pH 6.9, flow rate 2.0 mL/min) showed the product as a peak with a retention time of 5.5 min. Preparative HPLC followed by a workup similar to that of the other final products in the series afforded a white solid (49 mg, 96%): mp >300 °C; IR (KBr)  $\nu$  3430, 3210 br, 1620, 1585, 1525, 1470, 1410, 1355, 1320, 1280  $\text{cm}^{-1}$ ; UV  $\lambda_{\text{max}}$  (0.1 M HCl) 222 nm infl ( $\epsilon$  12,000), 278 (20,800), 302 infl (6,700);  $\lambda_{\text{max}}$  (pH 7.4 phosphate buffer) 219 nm ( $\epsilon$  30,300), 281 (30,000), 300 infl (17,900);  $\lambda_{\text{max}}$  (0.1 M NaOH) 217 nm ( $\epsilon$  28,600), 278 (24,100), 293 infl (19,900). Anal. ( $\text{C}_{19}\text{H}_{25}\text{N}_6\text{O}_7\text{P} \cdot 1.75\text{NH}_3 \cdot 4.5\text{H}_2\text{O}$ ) C, H, N.

**D,L-2-[(5,6,7,8-Tetrahydro-5-deazapteroyl)amino]-4-(ethoxyhydroxyphosphinyl)butanoic Acid (Ethyl 5-dH<sub>4</sub>PteAPBA, 19).** A solution of **35** (26 mg, 0.042 mmol) in DMSO (1 mL) was treated with 0.5 M NaOH (5 mL) and heated at 80 °C for 30 min. The solution was cooled and adjusted to pH 6.7 by dropwise addition of concentrated HCl. Analytical HPLC ( $\text{C}_{18}$  silica gel, 5% MeCN in 0.05 M  $\text{NH}_4\text{OAc}$ , pH 6.9, flow rate 2.0 mL/min) showed the product as a peak with a retention time of 6.5 min. After preparative HPLC using a similar system, pooled product fractions were concentrated by rotary evaporation and freeze-dried. The solid was redissolved in  $\text{H}_2\text{O}$ , and the solution was freeze-dried again to obtain a white solid (12 mg, 50%): mp >300 °C; IR (KBr)  $\nu$  3920, 3130–2990, 2950, 1710, 1660, 1615, 1585, 1555, 1525, 1465 w, 1410, 1355, 1315, 1280, 1225  $\text{cm}^{-1}$ . Anal. ( $\text{C}_{21}\text{H}_{29}\text{N}_6\text{O}_7\text{P} \cdot 0.5\text{NH}_3 \cdot 3\text{H}_2\text{O}$ ) C, H, N.

**Methyl  $\text{N}^\alpha$ -( $\text{N}^2$ -Acetyl- $\text{N}^{10}$ -formyl-5,6,7,8-tetrahydro-5-deazapteroyl)- $\text{N}^1$ -(benzyloxycarbonyl)-L-ornithinate (36).** A suspension of **34** (38.5 mg, 0.0906 mmol) in dry DMF (2 mL) was treated with  $\text{Et}_3\text{N}$  (10 mg, 14  $\mu\text{L}$ , 0.1 mmol) and *i*-BuOCOC1 (14 mg, 13.3  $\mu\text{L}$ , 0.1 mmol). A clear solution was obtained in ca. 2 min with the aid of an ultrasonication bath. Methyl  $\text{N}^\alpha$ -(benzyloxycarbonyl)-L-ornithinate (32 mg, 0.1 mmol) was then added, along with a second portion of  $\text{Et}_3\text{N}$  (10 mg, 14  $\mu\text{L}$ , 0.1 mmol). A second coupling cycle was then carried out, using 0.03 mmol each of  $\text{Et}_3\text{N}$ , *i*-BuOCOC1, and the amino ester. TLC (silica gel, 9:1  $\text{CHCl}_3$ -MeOH) showed a single mobile spot with  $R_f$  0.4. The solvent was evaporated under reduced pressure, and the residue was partitioned between  $\text{CHCl}_3$  and  $\text{H}_2\text{O}$ . The  $\text{CHCl}_3$  layer was evaporated, and the residue was purified by chromatography on a silica gel column (8 g,  $1.5 \times 14$  cm, 9:1  $\text{CHCl}_3$ -MeOH). Pooled pure fractions were concentrated to a small volume, and  $\text{Et}_2\text{O}$  was added to form a precipitate. The solid was collected and dried

in vacuo ( $P_2O_5$ , 60 °C) to obtain a white solid (37 mg, 62%): mp 175–188 °C (softening ca. 135 °C); IR (KBr)  $\nu$  3480, 2960, 1740 sh, 1700 sh, 1660, 1615, 1585, 1510, 1485, 1470, 1420 w, 1400, 1350 w, 1315, 1270, 1220  $cm^{-1}$ ; NMR ( $CDCl_3$  + DMSO- $d_6$ , 3:1)  $\delta$  1.5–2.5 (m,  $CH_2CO$ ,  $\beta$ - and  $\gamma$ - $CH_2$ ,  $C_5$ - $CH_2$ ,  $C_6$ -CH), 3.15 (m,  $\delta$ - $CH_2$ ,  $C_7$ - $CH_2$ ), 3.73 (s, MeO), 3.85 (m,  $C_9$ - $CH_2$ ), 4.60 (m,  $\alpha$ -CH, NH), 5.05 (s,  $C_6H_5CH_2O$ ), 5.50 (m, NH), 6.38 (m, NH), 7.35 (m,  $C_6H_5CH_2O$ ,  $C_9$ - and  $C_7$ -H), 7.56 (s, NH), 8.00 (d,  $J$  = 8 Hz,  $C_2$ - and  $C_8$ -H), 8.25 (m, NH), 8.53 (s,  $N^{10}$ -CHO). Anal. ( $C_{32}H_{37}N_7O_8 \cdot 0.5H_2O$ ) C, H, N.

**$N^2$ -(5,6,7,8-Tetrahydro-5-deazapteroyl)-L-ornithine (5-dH<sub>5</sub>PteOrn, 20).** A solution of 36 (88 mg, 0.134 mmol) in glacial AcOH (3 mL) was treated with 30% HBr in AcOH (3 mL). A precipitate formed on contact, but dissolved almost immediately. The solution was left to stand at room temperature for 45 min and then evaporated to dryness under reduced pressure. The residue was triturated with  $Et_2O$  (10 mL), the  $Et_2O$  was decanted, and the residue was taken up in  $H_2O$  (2 mL) by basification to pH 10 with 2 N NaOH. An additional 5 mL of 2 N NaOH was added, and the solution was sparged with  $N_2$  and heated in an oil bath kept at 80 °C for 30 min. The solution was cooled, and a small amount of brown solid was removed by filtration. The filtrate was adjusted to pH 6 with AcOH and subjected to preparative HPLC on  $C_{18}$  silica gel (analytical retention time 10 min; 1% AcOH, 5% EtOH, 1.0 mL/min). Pooled pure fractions were evaporated and the residue was freeze-dried to obtain a white solid (59 mg, 81%): mp >300 °C; IR (KBr)  $\nu$  3440, 2980, 2950, 1705, 1650 sh, 1615, 1580 sh, 1560, 1525, 1490 sh, 1415, 1350, 1315, 1285, 1235, 1205  $cm^{-1}$ ; UV  $\lambda_{max}$  (0.1 M HCl) 220 nm infl ( $\epsilon$  14,300), 279 (24,900), 302 infl (9,100);  $\lambda_{max}$  (pH 7.4 phosphate buffer) 219 nm ( $\epsilon$  35,100), 281, 31,700, 300 infl (21,200);  $\lambda_{max}$  (0.1 M NaOH) 278 nm ( $\epsilon$  26,500), 294 infl (21,700); NMR ( $CF_3CO_2H$ )  $\delta$  1.62 (m,  $\beta$ - and  $\gamma$ - $CH_2$ ,  $CH_3COOH$ ), 2.10 (m,  $C_5$ - $CH_2$ ,  $C_6$ -CH), 2.6–3.3 (m,  $C_7$ - $CH_2$ ,  $C_9$ - $CH_2$ ,  $\delta$ - $CH_2$ ), 4.40 (m,  $\alpha$ -CH), 7.0–7.6 (m,  $C_2$ -,  $C_3$ -,  $C_6$ -H). Anal. ( $C_{20}H_{27}O_4 \cdot CH_3CO_2H \cdot 3H_2O$ ) C, H, N.

Registry No. 13, 132343-86-3; 14, 139347-01-6; 14-NH<sub>3</sub>, 139347-18-5; 15, 139347-02-7; 15-<sup>5</sup>/<sub>4</sub>NH<sub>3</sub>, 139375-95-4; 16, 139347-03-8; 16-NH<sub>3</sub>, 139347-19-6; (6R)-L-17, 139347-04-9; (6R)-L-17-<sup>4</sup>/<sub>5</sub>NH<sub>3</sub>, 139347-20-9; (6S)-L-17, 139347-14-1; (6S)-L-17-<sup>4</sup>/<sub>5</sub>NH<sub>3</sub>, 139347-21-0; ( $R^*$ , $R^*$ )-(±)-18, 139347-05-0; ( $R^*$ , $R^*$ )-(±)-18-<sup>7</sup>/<sub>4</sub>NH<sub>3</sub>, 139347-22-1; ( $R^*$ , $S^*$ )-(±)-18, 139347-15-2; ( $R^*$ , $S^*$ )-(±)-18-<sup>7</sup>/<sub>4</sub>NH<sub>3</sub>, 139347-23-2; ( $R^*$ , $R^*$ )-(±)-19, 139347-06-1; ( $R^*$ , $R^*$ )-(±)-19-<sup>1</sup>/<sub>2</sub>NH<sub>3</sub>, 139347-24-3; ( $R^*$ , $S^*$ )-(±)-19, 139347-16-3; ( $R^*$ , $S^*$ )-(±)-19-<sup>1</sup>/<sub>2</sub>NH<sub>3</sub>, 139347-25-4; (6R)-L-20, 139347-07-2; (6R)-L-20-HOAc, 139347-26-5; (6S)-L-20, 139347-17-4; (6S)-L-20-HOAc, 139347-27-6; 21, 87373-56-6; 22, 139347-08-3; 24, 139347-09-4; 25, 139347-31-2; 25-<sup>1</sup>/<sub>4</sub>NH<sub>3</sub>, 139347-38-9; 26, 139347-32-3; 27-<sup>3</sup>/<sub>2</sub> oxalate, 139405-66-6; 27-HCl, 139405-64-4; 28-HCl, 139347-33-4; 29, 139347-34-5; 30, 139347-35-6; 31, 139347-36-7; 32, 139347-37-8; 33, 139375-96-5; 34, 139375-94-3; ( $R^*$ , $R^*$ )-(±)-35, 139347-10-7; ( $R^*$ , $S^*$ )-(±)-35, 139347-11-8; (6R)-L-36, 139347-12-9; (6S)-L-36, 139347-13-0; FPGS, 63363-84-8; GARFT, 9032-02-4; H-Orn(Z)-OMe, 62631-17-8; L- $H_2$ NCH( $C_6H_5$ )CO<sub>2</sub>H, 14857-77-3; L- $H_2$ NCH( $CH_2CH_2SO_3H$ )CO<sub>2</sub>Me, 139347-30-1; L- $H_2$ NCH( $CH_2CH_2SO_3^-$ )CO<sub>2</sub><sup>-2</sup> (PhCH<sub>2</sub>)Me<sub>3</sub>N<sup>+</sup>, 139347-29-8; DL- $H_2$ NCH(CO<sub>2</sub>H)CH<sub>2</sub>CH<sub>2</sub>PO<sub>3</sub>H<sub>2</sub>, 20263-07-4; 4- $O_2NC_6H_4COCl$ , 122-04-3; 4- $H_2NC_6H_4CO_2H$ , 150-13-0; (PhCH<sub>2</sub>)Me<sub>3</sub>N<sup>+</sup>MeO<sup>-</sup>, 122-08-7.

**Acknowledgment.** This work was supported by grants CA39867 (R.G.M., A.R.) and CA41461 (J.H.F.) from the National Cancer Institute, DHHS. The authors are indebted to Dr. G. Peter Beardsley and Ms. Barbara Moroson, Yale University School of Medicine, for carrying out some of the cytotoxicity assays, and to Mr. Scott Smith for his excellent technical assistance in carrying out GARFT and FPGS assays.

**Registry No.** 13, 132343-86-3; 14, 139347-01-6; 14-NH<sub>3</sub>, 139347-18-5; 15, 139347-02-7; 15-<sup>5</sup>/<sub>4</sub>NH<sub>3</sub>, 139375-95-4; 16, 139347-03-8; 16-NH<sub>3</sub>, 139347-19-6; (6R)-L-17, 139347-04-9; (6R)-L-17-<sup>4</sup>/<sub>5</sub>NH<sub>3</sub>, 139347-20-9; (6S)-L-17, 139347-14-1; (6S)-L-17-<sup>4</sup>/<sub>5</sub>NH<sub>3</sub>, 139347-21-0; ( $R^*$ , $R^*$ )-(±)-18, 139347-05-0; ( $R^*$ , $R^*$ )-(±)-18-<sup>7</sup>/<sub>4</sub>NH<sub>3</sub>, 139347-22-1; ( $R^*$ , $S^*$ )-(±)-18, 139347-15-2; ( $R^*$ , $S^*$ )-(±)-18-<sup>7</sup>/<sub>4</sub>NH<sub>3</sub>, 139347-23-2; ( $R^*$ , $R^*$ )-(±)-19, 139347-06-1; ( $R^*$ , $R^*$ )-(±)-19-<sup>1</sup>/<sub>2</sub>NH<sub>3</sub>, 139347-24-3; ( $R^*$ , $S^*$ )-(±)-19, 139347-16-3; ( $R^*$ , $S^*$ )-(±)-19-<sup>1</sup>/<sub>2</sub>NH<sub>3</sub>, 139347-25-4; (6R)-L-20, 139347-07-2; (6R)-L-20-HOAc, 139347-26-5; (6S)-L-20, 139347-17-4; (6S)-L-20-HOAc, 139347-27-6; 21, 87373-56-6; 22, 139347-08-3; 24, 139347-09-4; 25, 139347-31-2; 25-<sup>1</sup>/<sub>4</sub>NH<sub>3</sub>, 139347-38-9; 26, 139347-32-3; 27-<sup>3</sup>/<sub>2</sub> oxalate, 139405-66-6; 27-HCl, 139405-64-4; 28-HCl, 139347-33-4; 29, 139347-34-5; 30, 139347-35-6; 31, 139347-36-7; 32, 139347-37-8; 33, 139375-96-5; 34, 139375-94-3; ( $R^*$ , $R^*$ )-(±)-35, 139347-10-7; ( $R^*$ , $S^*$ )-(±)-35, 139347-11-8; (6R)-L-36, 139347-12-9; (6S)-L-36, 139347-13-0; FPGS, 63363-84-8; GARFT, 9032-02-4; H-Orn(Z)-OMe, 62631-17-8; L- $H_2$ NCH( $C_6H_5$ )CO<sub>2</sub>H, 14857-77-3; L- $H_2$ NCH( $CH_2CH_2SO_3H$ )CO<sub>2</sub>Me, 139347-30-1; L- $H_2$ NCH( $CH_2CH_2SO_3^-$ )CO<sub>2</sub><sup>-2</sup> (PhCH<sub>2</sub>)Me<sub>3</sub>N<sup>+</sup>, 139347-29-8; DL- $H_2$ NCH(CO<sub>2</sub>H)CH<sub>2</sub>CH<sub>2</sub>PO<sub>3</sub>H<sub>2</sub>, 20263-07-4; 4- $O_2NC_6H_4COCl$ , 122-04-3; 4- $H_2NC_6H_4CO_2H$ , 150-13-0; (PhCH<sub>2</sub>)Me<sub>3</sub>N<sup>+</sup>MeO<sup>-</sup>, 122-08-7.

## Synthesis and Evaluation of a New Series of Mechanism-Based Aromatase Inhibitors

D. Lesuisse,\* J. F. Gourvest, C. Hartmann, B. Tric, O. Benslimane, D. Philibert, and J. P. Vevert

Centre de Recherches Roussel-UCLAF, 102 Route de Noisy, 93230 Romainville, France. Received August 9, 1991

A series of new 4-(alkylthio)-substituted androstenedione analogues was designed as potential suicide inhibitors of aromatase on the basis of mechanistic considerations on the mode of action of the enzyme. Their synthesis and biological evaluation are described. Among the most interesting are the 4-[(difluoromethyl)thio]-, 4-[(fluoromethyl)thio]-, and 4-[(chloromethyl)thio]androstenediones 12, 13, and 14 with respective  $IC_{50}$ 's of 2.7, 0.8, and 0.94  $\mu$ M. Compound 12 was a reversible inhibitor of aromatase while compounds 13 and 14 displayed time-dependent kinetics of inhibition with respective  $K_i$ 's and half-times of inactivation of 30 nM and 3.75 min for 13 and 30 nM and 3 min for 14. The inhibition of aromatase by 14 was NADPH-dependent, and was protected by the presence of substrate (0.5–1  $\mu$ M), while  $\beta$ -mercaptoethanol (0.5 mM) failed to protect the enzyme from inactivation. Dialysis failed to reactivate aromatase previously inactivated by 14. The mechanistic implications of these findings are discussed.

### Introduction

Breast cancer is among the most common malignancies in women today. In the US alone about 130 000 cases are reported each year.<sup>1</sup> In the case of ER + tumors, ablative therapy is more and more frequently replaced by endocrine palliative treatment. Today, medical endocrine treatment of advanced postmenopausal breast cancer largely falls within three groups:<sup>2</sup> (a) antiestrogens, acting directly on

the tumor cell via the receptor, (b) aromatase inhibitors, suppressing estrogen production, (c) progestins, of which the mechanism of action is still uncertain.<sup>3</sup>

The major pathway of estrogen production in postmenopausal women is the peripheral conversion of androgens to estrogens. The enzyme that catalyzes this conversion is a cytochrome P-450 dependent monooxygenase, aromatase. Although the mechanism of this reaction is still the subject of controversy, most authors agree today that

(1) Young, J. L., Jr. *Breast Cancer*; Alan R. Liss, Inc.: New York, 1989; I-5, chapter 1, pp 1-5.  
(2) Lønning, P. E.; Dowsett, M.; Powles, T. J. Postmenopausal Estrogen Synthesis and Metabolism: Alterations Caused by Aromatase Inhibitors Used for the Treatment of Breast Cancer. *J. Steroid Biochem.* 1990, 35, 355-356.

(3) Lundgren, S.; Lønning, P. E.; Utaaker, E.; Aakvaag, A.; Kwinnslund, S. Influence of Progestins on Serum Hormone Levels in Postmenopausal Women with Advanced Breast Cancer. I. General Findings. *J. Steroid Biochem.* 1990, 36, 99-104.