

## REACTIONS OF TRANSITION METAL COMPOUNDS WITH MACROCYCLIC ALKADIYNES

### II. CYCLOPENTADIENYLNICKEL AND DICOBALT HEXACARBONYL COMPLEXES RETAINING THE MACROCYCLIC ALKADIYNE STRUCTURE UNIT\*

R. B. KING, IONEL HAIDUC\*\* and A. EFRATY\*\*\*

*Department of Chemistry, University of Georgia, Athens, Georgia 30601 (U.S.A.)*

(Received June 13th, 1972)

#### SUMMARY

The macrocyclic alkadiynes 1,7-cyclododecadiyne, 1,7-cyclotridecadiyne, 1,7-cyclotetradecadiyne, 1,8-cyclotetradecadiyne, and 1,8-cyclopentadecadiyne react with  $[C_5H_5NiCO]_2$  in boiling benzene to give the dark green tetrametallic derivatives (alkadiyne)  $(NiC_5H_5)_4$  and with  $Co_2(CO)_8$  in pentane at room temperature to give the dark red tetrametallic derivatives (alkadiyne)  $[Co_2(CO)_6]_2$ . The reactions of 1,7-cyclododecadiyne with  $[C_5H_5NiCO]_2$  and  $Co_2(CO)_8$  can also be made to give the crystalline bimetallic derivatives  $1,7-C_{12}H_{16}(NiC_5H_5)_2$  and  $1,7-C_{12}H_{16}Co_2(CO)_6$ . The macrocyclic alkadiyne ring system is retained in all of these new complexes.

#### INTRODUCTION

Previous papers from this laboratory describe intramolecular transannular cyclizations of the macrocyclic alkadiynes I ( $m=4, n=4, 5, 6; m=5, n=5, 6$ ) with cyclopentadienylcobalt derivatives and iron carbonyls to give tricyclic cyclobutadiene derivatives of the stoichiometries  $C_5H_5Co(alkadiyne)$  (II)<sup>1</sup> and  $(alkadiyne)Fe(CO)_3$  (III)<sup>2a</sup>, metallacyclopentadiene derivatives of the stoichiometry  $(alkadiyne)Fe_2(CO)_6$ <sup>2a</sup> and tricyclic cyclopentadienyl derivatives of the stoichiometry  $[(alkadiyne-H)-Fe(CO)_2]_2$  (IV)<sup>2b</sup>. This paper describes reactions of the same macrocyclic alkadiynes I ( $m=4, n=4, 5$  and  $6; m=5, n=5$  and  $6$ ) with the cyclopentadienylnickel derivative  $[C_5H_5NiCO]_2$  and with the cobalt carbonyl  $Co_2(CO)_8$  which differ from the previously reported<sup>1,2</sup> reactions in that complexes of the types V and VI are formed in which the macrocyclic alkadiyne unit is retained intact without transannular cyclization reactions. Such complexes are rare examples of transition metal derivatives of macrocyclic hydrocarbon ring systems. Previous examples of transition metal

\* For part I see ref. 1.

\*\* Permanent staff member of the Department of Chemistry, Babeş-Bolyai University, Cluj, Romania, on leave during 1971-1972 in the Department of Chemistry, University of Georgia.

\*\*\* Post-doctoral research associate 1968-1971. Present address: Department of Chemistry, Rutgers University, New Brunswick, New Jersey.

derivatives of macrocyclic hydrocarbon ring systems include mainly 1,5,9-cyclododecatriene derivatives of metals such as nickel<sup>3</sup> and ruthenium<sup>4</sup>.

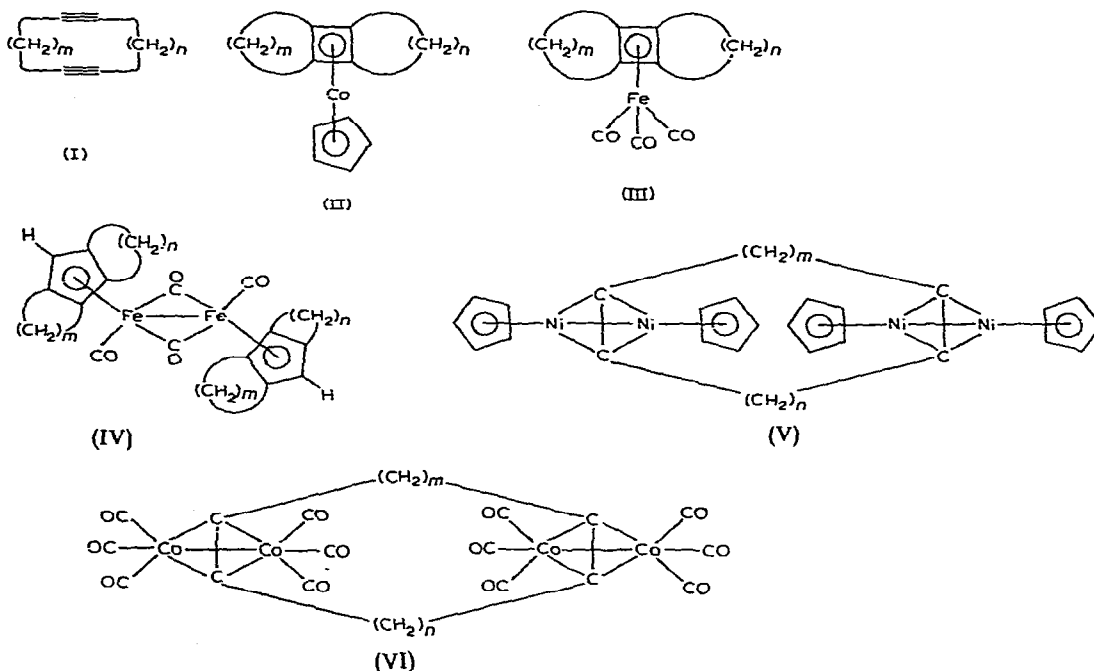

## EXPERIMENTAL

Microanalyses (Tables 1 and 2) were performed by Meade Microanalytical Laboratory, Amherst, Massachusetts. Melting points (Tables 1 and 2) were taken in capillaries and are uncorrected. Infrared spectra in the  $2000\text{ cm}^{-1}$   $\nu(\text{CO})$  region (Table 3) were taken in saturated hydrocarbon solvents (generally pentane or hexane) and recorded on a Perkin-Elmer 621 spectrometer with grating optics. Each spectrum was calibrated with the  $1601$  or  $1944\text{ cm}^{-1}$  bands of a polystyrene film. Proton NMR spectra (Tables 1 and 2) were taken in  $\text{CDCl}_3$  solutions and recorded at 60 MHz. on a Perkin-Elmer Hitachi R-20 spectrometer.

A nitrogen atmosphere was routinely provided for the following operations: (a) carrying out reactions; (b) admitting to evacuated vessels; and (c) handling filtered solutions of organometallic compounds. In addition, the analytical samples were recrystallized in an atmosphere of nitrogen by using Schlenk tubes and related apparatus.

The  $\text{Co}_2(\text{CO})_8$  was purchased from Strem Chemicals, Inc., Danvers, Massachusetts. The  $[\text{C}_5\text{H}_5\text{NiCO}]_2$  was prepared from commercial  $\text{Ni}(\text{CO})_4$  and  $(\text{C}_5\text{H}_5)_2\text{Ni}$  by the published procedure<sup>5</sup>. The macrocyclic alkadiynes 1,7-cyclododecadiyne (I,  $m=4$ ,  $n=4$ ), 1,7-cyclotridecadiyne (I,  $m=4$ ,  $n=5$ ), 1,7-cyclotetradecadiyne (I,  $m=4$ ,  $n=6$ ), 1,8-cyclotetradecadiyne (I,  $m=5$ ,  $n=5$ ), and 1,8-cyclopentadecadiyne (I,  $m=5$ ,  $n=6$ ) were purchased from Farchan Research Laboratories, Willoughby, Ohio.

TABLE I  
 CYCLOPENTADIENYLNICKEL COMPLEXES OF THE MACROCYCLIC ALKADIYNES

Compound <sup>a</sup>	M.p. <sup>b</sup>	Yield (%)	Analyses (%)		Proton NMR spectrum ( $\tau$ ) <sup>c</sup>	
			found (calcd.)		$\pi$ -C <sub>5</sub> H <sub>5</sub> <sup>d</sup>	CH <sub>2</sub> <sup>e</sup>
			C	H		
1,7-C <sub>12</sub> H <sub>16</sub> (NiCp) <sub>2</sub>	99–100°	39	64.5 (64.8)	6.5 (6.4)	4.76(10)	7.14(4), ~8.0(4) ~8.3(4), ~8.7(4)
1,7-C <sub>12</sub> H <sub>16</sub> (NiCp) <sub>4</sub>	180–190° (dec.)	47	58.9 (58.6)	5.6 (5.5)	4.85(20)	~7.5(8), ~8.6(8)
1,7-C <sub>13</sub> H <sub>18</sub> (NiCp) <sub>4</sub>	165°	64	59.4 (59.2)	5.8 (5.6)	4.95(20)	~7.5(8), ~8.6(10)
1,7-C <sub>14</sub> H <sub>20</sub> (NiCp) <sub>4</sub>	155–157°	70	59.7 (59.7)	5.6 (5.8)	4.95(20)	7.50(8), 8.76(12)
1,8-C <sub>14</sub> H <sub>20</sub> (NiCp) <sub>4</sub>	180–185°	41	59.6 (59.7)	5.9 (5.8)	4.95(20)	7.52(8), 8.76(12)
1,8-C <sub>15</sub> H <sub>22</sub> (NiCp) <sub>4</sub>	130–131°	35	60.0 (60.3)	5.9 (6.0)	4.94(20)	7.53(8), 8.78(14)

<sup>a</sup> Cp =  $\pi$ -cyclopentadienyl.

<sup>b</sup> All compounds listed in this table were dark green solids.

<sup>c</sup> These NMR spectra were all run in chloroform-*d* solution. The number of protons corresponding to each resonance is given in parentheses.

<sup>d</sup> All of the  $\pi$ -cyclopentadienyl resonances were sharp singlets.

<sup>e</sup> All of the methylene resonances were broad. The positions of the approximate midpoints are given.

TABLE 2

## DICOBALT HEXACARBONYL COMPLEXES OF THE MACROCYCLIC ALKADIYNES

Compound	M.p. <sup>a</sup>	Yield (%)	Analyses (%) found (calcd.)				Mol.wt. <sup>b</sup>	Proton NMR spectrum ( $\tau$ ) <sup>c</sup> CH <sub>2</sub> <sup>d</sup>
			C	H	O	Co		
1,7-C <sub>12</sub> H <sub>16</sub> Co <sub>2</sub> (CO) <sub>6</sub>	> 100° (dec.)	49	47.0 (48.4)	4.0 (3.6)	21.3 (21.5)	27.6 (26.5)	525 (446)	7.18(4), 7.75(4), 8.32(8)
1,7-C <sub>12</sub> H <sub>16</sub> [Co <sub>2</sub> (CO) <sub>6</sub> ] <sub>2</sub>	198–200° (dec.)	44	39.1 (39.1)	2.4 (2.2)	25.5 (26.2)	33.2 (32.3)		7.00(8), 8.27(8)
1,7-C <sub>13</sub> H <sub>18</sub> [Co <sub>2</sub> (CO) <sub>6</sub> ] <sub>2</sub>	128°	56	40.1 (40.2)	2.4 (2.5)	25.6 (25.7)	31.9 (31.7)	721 (746)	7.05(8), 8.30(10)
1,7-C <sub>14</sub> H <sub>20</sub> [Co <sub>2</sub> (CO) <sub>6</sub> ] <sub>2</sub>	65–66°	75	41.0 (41.0)	2.7 (2.6)	25.2 (25.2)	31.1 (31.0)	789 (760)	7.10(8), 8.35(12)
1,8-C <sub>14</sub> H <sub>20</sub> [Co <sub>2</sub> (CO) <sub>6</sub> ] <sub>2</sub>	175–178° (dec.)	56	41.2 (41.0)	2.2 (2.6)	25.5 (25.2)	30.7 (31.0)	757 (760)	7.10(8), 8.45(12)
1,8-C <sub>15</sub> H <sub>22</sub> [Co <sub>2</sub> (CO) <sub>6</sub> ] <sub>2</sub>	134–135°	93	41.8 (41.7)	2.9 (2.8)	24.7 (24.8)	30.3 (31.7)	787 (774)	7.10(8), 8.50(14)

<sup>a</sup> All compounds listed in this table were dark red solids.

<sup>b</sup> These molecular weights were determined by the vapor pressure osmometer in benzene solution.

<sup>c</sup> These NMR spectra were all run in chloroform-*d* solution. The number of protons corresponding to each resonance is given in parentheses.

<sup>d</sup> All of these methylene resonances were broad. The positions of the approximate midpoints are given.

### Reactions of $[C_5H_5NiCO]_2$ with the macrocyclic alkadiynes (I)

A mixture of 2.5 to 5.0 mmoles ( $\sim 0.4$  to  $\sim 1.0$  g) of the macrocyclic alkadiyne (I), 5.0 to 10.0 mmoles of  $[C_5H_5NiCO]_2$ , and 125 to 150 ml of benzene was boiled under reflux for 18 to 24 h. Generally two moles of  $[C_5H_5NiCO]_2$  were used for each mole of the macrocyclic alkadiyne I. Solvent was removed from the resulting reaction mixture at  $35^\circ/50$  mm. The dark green semisolid residue was dissolved in a minimum volume of pentane or benzene and chromatographed on a  $2 \times 60$  cm Florisil column. The chromatogram was developed with hexane. The green band(s) were eluted with hexane containing gradually increasing volumes of benzene. Solvent was removed from the green eluates at  $35^\circ/50$  mm. In some cases the early fractions gave viscous dark green liquids in quantities too small for characterization; these were probably the corresponding (alkadiyne)( $NiC_5H_5$ )<sub>2</sub> derivatives. The later fractions gave dark green solids upon evaporation. These crude products were purified by low temperature crystallization from hexane to give pure samples of the dark green (alkadiyne)( $NiC_5H_5$ )<sub>4</sub> derivative.

In some experiments 3 to 4.5 mmoles of  $[C_5H_5NiCO]_2$  were used for each mole of the macrocyclic alkadiyne I. In these experiments pure samples of the corresponding (alkadiyne)( $NiC_5H_5$ )<sub>4</sub> derivative could be isolated by simple crystallization from pentane or hexane without the need for chromatography.

The reaction between 1,7-cyclododecadiyne (I,  $m=4$ ,  $n=4$ ) and  $[C_5H_5NiCO]_2$  was investigated in more detail since both the products (alkadiyne)( $NiC_5H_5$ )<sub>2</sub> and (alkadiyne)( $NiC_5H_5$ )<sub>4</sub> were crystalline. A mixture of 0.80 g (5 mmoles) of 1,7-cyclododecadiyne, 4.0 g (13.3 mmoles) of  $[C_5H_5NiCO]_2$ , and 150 ml of benzene was boiled under reflux for 20 h. The reaction mixture was concentrated to 25 ml at  $40^\circ/50$  mm and then chromatographed on a  $2 \times 60$  cm Florisil column. The column was first eluted with pure hexane. Evaporation of this eluate gave a small amount of ( $C_5H_5$ )<sub>2</sub>Ni. The first intense green zone was eluted with a mixture of benzene and hexane. Evaporation of this eluate gave 0.8 g (39% yield) of a dark green solid, m.p.,  $99-100^\circ$ , which was 1,7- $C_{12}H_{16}(NiC_5H_5)_2$ . A second green zone was eluted with pure benzene. Evaporation of this green eluate gave 1.5 g (46% yield) of dark green 1,7- $C_{12}H_{16}(NiC_5H_5)_4$ , dec.  $190-200^\circ$ .

### Reactions of $Co_2(CO)_8$ with the Macrocyclic Alkadiynes (I)

(a) Reaction of  $Co_2(CO)_8$  with 1,7-cyclododecadiyne in a 1/1 mole ratio. A solution of 1.1 g (6.8 mmoles) of 1,7-cyclododecadiyne in 50 ml of hexane was treated dropwise over 40 minutes with a solution of 2.3 g (6.7 mmoles) of  $Co_2(CO)_8$  in 300 ml of hexane. The reaction mixture was then stirred at room temperature for 14 h. Solvent was removed at  $25^\circ/25$  mm. The residue was dissolved in a minimum volume of pentane and chromatographed on a  $2.5 \times 60$  cm Florisil column prepared in pentane. The single red band was eluted with pentane. Concentration of the pentane eluate at 35 mm and cooling to  $-78^\circ$  gave 1.43 g (48% yield) of dark red 1,7- $C_{12}H_{16}Co_2(CO)_6$  collected in three crops.

(b) Reaction of  $Co_2(CO)_8$  with 1,7-cyclododecadiyne in a 2/1 mole ratio. A mixture of 0.85 g (5.3 mmoles) of 1,7-cyclododecadiyne, 3.8 g (11.1 mmoles) of  $Co_2(CO)_8$ , and 100 ml of pentane was stirred for 24 h at room temperature. Some red crystals separated. Solvent was then removed from the reaction mixture at  $25^\circ/40$  mm. The red crystalline residue was washed with pentane and then crystallized from a

mixture of pentane and dichloromethane to give a total of 1.70 g (44% yield) of dark red  $1,7-C_{12}H_{16}[Co_2(CO)_6]_2$  collected in two crops.

(c) *Reactions of  $Co_2(CO)_8$  with the other macrocyclic alkadiynes.* A mixture of 5.0 mmoles (0.8 to 1.0 g) of the macrocyclic alkadiyne I, 3.42 g (10 mmoles) of  $Co_2(CO)_8$ , and 100 to 150 ml of pentane was stirred for ~ 15 h at room temperature. Solvent was removed from the reaction mixture at 25°/40 mm. A concentrated pentane solution of the residue was chromatographed on a 2 × 60 cm Florisil column. The single red band of the (alkadiyne) $[Co_2(CO)_6]_2$  derivative was eluted with pentane. Dichloromethane was added to the pentane eluant to increase the elution rate of the 1,8-cyclotetradecadiyne derivative. Solvent was removed from the eluate at 25°/40 mm. The dark red (alkadiyne) $[Co_2(CO)_6]_2$  derivatives could be purified further by recrystallization from pentane.

## DISCUSSION

The reactions of the macrocyclic alkadiynes (I,  $m=4$ ,  $n=4$ , 5 and 6;  $m=5$ ,  $n=5$  and 6) with  $[C_5H_5NiCO]_2$  and  $Co_2(CO)_8$  gave the tetrametallic compounds of stoichiometries (alkadiyne) $(NiC_5H_5)_4$  and (alkadiyne) $[Co_2(CO)_6]_2$ , respectively. These compounds appear to have structures V and VI with intact macrocyclic alkadiyne ligands and with each carbon-carbon triple bond of the alkadiyne system bonded to a different bimetallic unit in a manner similar to the known alkyne complexes of stoichiometries (alkyne) $(NiC_5H_5)_2$ <sup>5a,6</sup> and (alkyne) $Co_2(CO)_6$ <sup>7</sup>.

The nickel compounds (alkadiyne) $(NiC_5H_5)_4$  were dark green solids which were somewhat air-sensitive in solution. The proton NMR spectra of these nickel compounds V (Table 1) exhibited the expected sharp singlet resonances from the 20 equivalent cyclopentadienyl protons and the expected broad saturated methylene resonances. The relative intensities of these two types of resonances were in accord with the proposed structures V.

The cobalt compounds (alkadiyne) $[Co_2(CO)_6]_2$  were dark red solids. Their infrared spectra in the  $\nu(CO)$  region (Table 3) under fairly high resolution conditions exhibited six distinct bands at  $2095 \pm 4$ ,  $2055 \pm 3$ ,  $2032 \pm 2$ ,  $2020 \pm 2$ ,  $2005 \pm 3$ , and  $1974 \pm 3$   $cm^{-1}$ . The previously reported<sup>7</sup> (alkyne) $Co_2(CO)_6$  derivatives were reported to exhibit  $\nu(CO)$  frequencies at 2084, 2050, and 2024  $cm^{-1}$ . These patterns in the  $\nu(CO)$  region are consistent with each other when allowance is made for the probable

TABLE 3

INFRARED SPECTRA OF SOME DICOBALT HEXACARBONYL COMPLEXES OF THE MACROCYCLIC ALKADIYNES

Compound	Infrared spectrum ( $cm^{-1}$ )	
	Solvent	$\nu(CO)$ frequencies
$1,7-C_{12}H_{16}Co_2(CO)_6$	pentane	2093 m, 2052 s, 2030 s, 2020 s, 2008 w, 1974 w
$1,7-C_{12}H_{16}[Co_2(CO)_6]_2$	pentane	2091 m, 2057 s, 2031 s, 2018 s, 1972 vw
$1,7-C_{13}H_{18}[Co_2(CO)_6]_2$	hexane	2091 m, 2052 s, 2030 s, 2018 s, 2002 m, 1972 w
$1,8-C_{14}H_{20}[Co_2(CO)_6]_2$	pentane	2093 s, 2055 s, 2032 s, 2020 s, 2004 s, 1974 w
$1,8-C_{15}H_{22}[Co_2(CO)_6]_2$	pentane	2098 s, 2058 s, 2034 s, 2022 s, 2005 s, 1977 w

difficulty in resolving the 2032, 2020, and 2004  $\text{cm}^{-1}$  bands from each other under the lower resolution used in the earlier work<sup>7</sup>, the weakness of the 1974  $\text{cm}^{-1}$  band, and the lack of precise calibration of the earlier work.

The saturated methylene protons in the proton NMR spectra of both the (alkadiyne)( $\text{NiC}_5\text{H}_5$ )<sub>4</sub> and the (alkadiyne)[ $\text{Co}_2(\text{CO})_6$ ]<sub>2</sub> derivatives exhibit two distinct broad resonances. The lower field methylene resonance, which appeared around  $\tau$  7.5 for the nickel derivatives V and around  $\tau$  7.1 for the cobalt derivatives VI, may be assigned to the eight protons of the four methylene groups adjacent to the complexed carbon-carbon triple bonds in V and VI on the basis of its approximate relative intensity. The higher field resonance, which appeared around  $\tau$  8.7 for the nickel derivatives V and around  $\tau$  8.4 for the cobalt derivatives VI, may be assigned to all of the remaining methylene groups in the macrocyclic alkadiyne ligand. The methylene protons not directly adjacent to the complexed carbon-carbon triple bonds in V and VI but different distances away exhibited chemical shifts so similar that their broad resonances could not be resolved.

Attempts were made to prepare bimetallic complexes of the types (alkadiyne)-( $\text{NiC}_5\text{H}_5$ )<sub>2</sub> (VII) and (alkadiyne) $\text{Co}_2(\text{CO})_6$  (VIII) with only one of the two carbon-carbon triple bonds of the macrocyclic alkadiyne bonded to transition metals. However, the only crystalline products of these types which could be obtained were the 1,7-cyclododecadiyne complexes 1,7- $\text{C}_{12}\text{H}_{16}(\text{NiC}_5\text{H}_5)_2$  (VII,  $m=4$ ,  $n=4$ ) and 1,7- $\text{C}_{12}\text{H}_{16}\text{Co}_2(\text{CO})_6$  (VIII,  $m=4$ ,  $n=4$ ). These bimetallic 1,7-cyclododecadiyne complexes were eluted more readily from a chromatography column than the corresponding tetrametallic 1,7-cyclododecadiyne complexes of types V and VI ( $m=n=4$ ). Some of the other macrocyclic alkadiynes gave small amounts of viscous liquid products with [ $\text{C}_5\text{H}_5\text{NiCO}$ ]<sub>2</sub> and/or  $\text{Co}_2(\text{CO})_8$  in addition to the crystalline tetrametallic derivatives of the type (alkadiyne)( $\text{NiC}_5\text{H}_5$ )<sub>4</sub> (V) and (alkadiyne)[ $\text{Co}_2(\text{CO})_6$ ]<sub>2</sub> (VI). These may be the corresponding bimetallic derivatives of the type

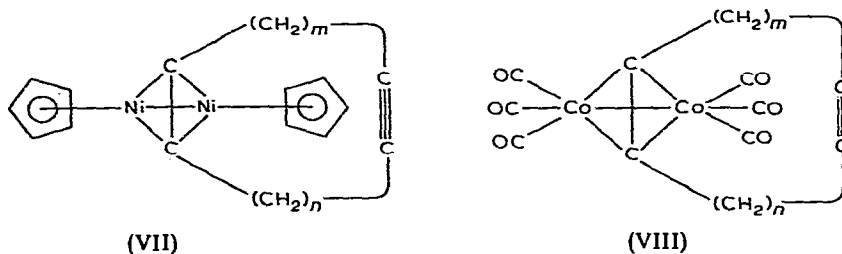

(alkadiyne)( $\text{NiC}_5\text{H}_5$ )<sub>2</sub> (VII) and (alkadiyne) $\text{Co}_2(\text{CO})_6$  (VII) on the basis of their elution from a chromatography column before the corresponding tetrametallic derivatives. However, these viscous liquid products could be obtained neither in the crystalline state nor even in sufficient purity and quantities for identification and characterization.

The reactions between the macrocyclic alkadiynes I and  $\text{Co}_2(\text{CO})_8$  proceeded readily at room temperature in inert saturated hydrocarbon solvents (*e.g.* pentane or hexane) to give the corresponding dark red (alkadiyne)[ $\text{Co}_2(\text{CO})_6$ ]<sub>2</sub> (VI) derivatives. These reaction conditions are similar to the reaction conditions used to convert alkynes with only one carbon-carbon triple bond (*e.g.* diphenylacetylene or even

acetylene itself) to the corresponding (alkyne) $\text{Co}_2(\text{CO})_6$  derivative<sup>7</sup>. Reactions of  $\text{Co}_2(\text{CO})_8$  with the macrocyclic alkadiynes I in boiling 2,2,5-trimethylhexane ( $\sim 124^\circ$ ) gave blue solids which could not be obtained completely pure. The infrared spectra of these blue compounds exhibited several terminal  $\nu(\text{CO})$  frequencies (e.g. 2091, 2053, 2042, 2032, 2018, and 1981  $\text{cm}^{-1}$  for the 1,7-cyclododecadiyne derivative) and a single bridging  $\nu(\text{CO})$  frequency around 1876  $\text{cm}^{-1}$ . The blue color of these materials resembles the blue color reported<sup>8</sup> for (alkyne) $\text{Co}_4(\text{CO})_{10}$  derivatives. Formulation as a tetracobalt derivative is supported by analytical and solution molecular weight data for the 1,7-cyclotridecadiyne derivative which approach the values expected for the stoichiometry (alkadiyne) $_2\text{Co}_4(\text{CO})_n$  (Found: C, 49.8; H, 4.6; Co, 31.4; mol. wt., 939). (Calcd. for  $n=8$ : C, 50.5; H, 4.5, Co, 29.2; mol. wt., 808.). However, the analytical data on these blue compounds were not very reproducible apparently owing to purification problems. Therefore, attempts to synthesize and characterize these blue compounds from reactions of the macrocyclic alkadiynes I with  $\text{Co}_2(\text{CO})_8$  were abandoned.

#### ACKNOWLEDGMENT

We are indebted to the National Science Foundation for partial support of this work under Grants GP-9662 and GP-31347X.

#### REFERENCES

- 1 R. B. King and A. Efraty, *J. Amer. Chem. Soc.*, 94 (1972) 3021.
- 2 (a) R. B. King and I. Haiduc, *J. Amer. Chem. Soc.*, 94 (1972) 4044; (b) R. B. King and C. W. Eavenson, *J. Organometal. Chem.*, 15 (1969) P75.
- 3 B. Bogdanović, M. Kroner and G. Wilke, *Ann.*, 699 (1966) 1.
- 4 M. I. Bruce, M. A. Cairns, A. Cox, M. Green, M. D. H. Smith and P. Woodward, *Chem. Commun.*, (1970) 735.
- 5 (a) J. F. Tilney-Bassett, *J. Chem. Soc.*, (1961) 377; (b) R. B. King, *Organometal. Syn.*, 1 (1965) 119.
- 6 M. Dubeck, *J. Amer. Chem. Soc.*, 82 (1960) 502 and 6193.
- 7 H. Greenfield, H. W. Sternberg, R. A. Friedel, J. H. Wotiz, R. Markby and I. Wender, *J. Amer. Chem. Soc.*, 78 (1956) 120.
- 8 (a) U. Krüerke and W. Hübel, *Ber.*, 94 (1961) 2829; (b) L. F. Dahl and D. L. Smith, *J. Amer. Chem. Soc.*, 84 (1962) 2450.