

Preliminary communication

ACYLALUMINUM DICHLORIDES

DENISE B. CARR and JEFFREY SCHWARTZ*

Department of Chemistry, Princeton University Princeton, New Jersey 08540 (U.S.A.)

(Received May 13th, 1977)

Summary

Evidence has been obtained for the formation of acylaluminum dichlorides by transmetalation between $Cp_2Zr(Cl)(acyl)$ and $AlCl_3$. They have been shown to be reactive toward electrophiles at both the carbon and the oxygen of the acyl group.

“Acyl anion equivalents” (or nucleophilic acylation reagents) are of recurrent interest since they can provide a direct route for the synthesis of many classes of organic compounds [1a]. Two broad classes of acyl anion equivalents are known. (1) elaborately masked carbonyl functional groups, and (2) acylmetallic compounds. Members of this latter category are potentially useful reagents in a direct sense. However, derivatives of main group metals have, heretofore, not been readily available since routes to their preparation (see reaction 1) are stymied by condensation side reactions (in 1a the acylmetallic

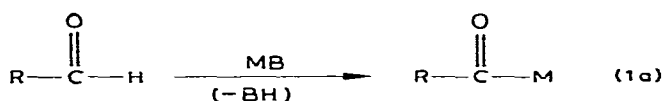

M = main group metal

B = basic ligand

*Author to whom correspondence should be addressed

species once formed can attack the starting aldehyde, while in 1b the acylmetal can add RM)*. Acyl-transition metal complexes, although well known and most often readily prepared from alkyl-transition metals and CO, are of limited use as acylation agents [2]. It was therefore of interest to learn if a readily obtainable acyl-transition metal derivative could be used to prepare a main group acylmetallic compound in the absence of a substrate (aldehyde or alkyl-metal) which could destroy it by condensation. The reactivity of such a species as an acyl anion equivalent could then be investigated. We previously found that transmetalation between organozirconium compounds and AlCl_3 is a facile route to alkyl- and alkenyl-aluminium dichlorides [3], and we now wish to report that acylaluminium dichlorides can be prepared in similar fashion (reaction 2).

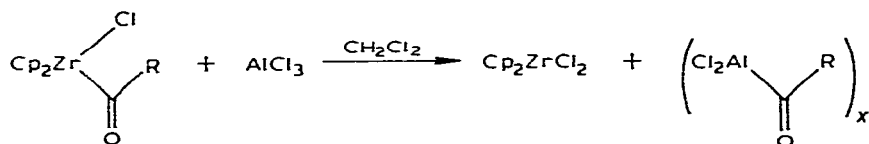

(I a, R = $\text{CH}_2\text{CH}_2\text{C}(\text{CH}_3)_3$,

I b, R = $(\text{CH}_2)_2\text{CH}_3$)

(II)

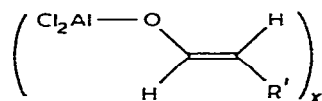

(III a, R = $(t\text{-C}_4\text{H}_9)\text{CH}_2$,

III b, R = CH_3CH_2)

In a typical experiment, a solution of 1.25 mmol of Ia in CH_2Cl_2 was added to a suspension of 2.25 mmol AlCl_3 in CH_2Cl_2 at -20°C . Low-temperature NMR analysis (at -20°C) after 10 min indicated the complete absence of Ia and the presence of Cp_2ZrCl_2 as well as resonances at δ (ppm) 0.9 (broadened singlet), 1.57 (multiplet) and 3.38 (multiplet) attributed to IIa. Infrared analysis of the carbonyl region of the cold reaction mixture revealed a strong absorbance at $\nu(\text{C}=\text{O})$ 1530 cm^{-1} **. Warming the reaction mixture to room temperature resulted in deterioration of both the NMR and the infrared spectra. Hydrolysis of the reaction mixture resulted in changes in both spectra and gave 4,4-dimethylpentaldehyde (43%)***. Also present in low yield in each

* Acyltriphenylsilanes have been prepared [1b]; the chemistry of these species as acyl anion equivalents has not been investigated

** Note that for Ia $\nu(\text{CO})$ 1550 cm^{-1} [2c]. An X-ray structural determination for the compound $\text{Cp}_2\text{Zr}(\text{COCH}_2)\text{CH}_3$ ($\nu(\text{CO})$ 1545 cm^{-1}) [4] indicates that the acyl ligand bonds to zirconium via both the carbon and oxygen atoms. Perhaps a similar explanation accounts for the observed $\nu(\text{CO})$ in these aluminum compounds

*** Yield based on Ia. 4,4-Dimethylpentaldehyde was identified by comparison with an authentic sample.

hydrolyzed reaction mixture were products derived from decarbonylation of IIa· 2,2,8,8-tetramethyl-5-nonanone [5] and *neo*-hexylbenzene* The amount of CO released when IIa was stored at -15°C overnight was 0.11 equiv

To prove that IIa is indeed a "direct" acylmetallic species and not an enolate, III, a sample of IIa was treated with D_2O and the resultant aldehyde was analyzed for deuterium content and position of substitution In this way NMR and mass spectral analysis shows that the aldehyde formed is at least 83% $-\text{C}(\text{O})-\text{D}$ Treating II with acetyl chloride give some α -diketone (IV)** as shown in reaction 3. However, a major product of this reaction (at 5°C) is V, which

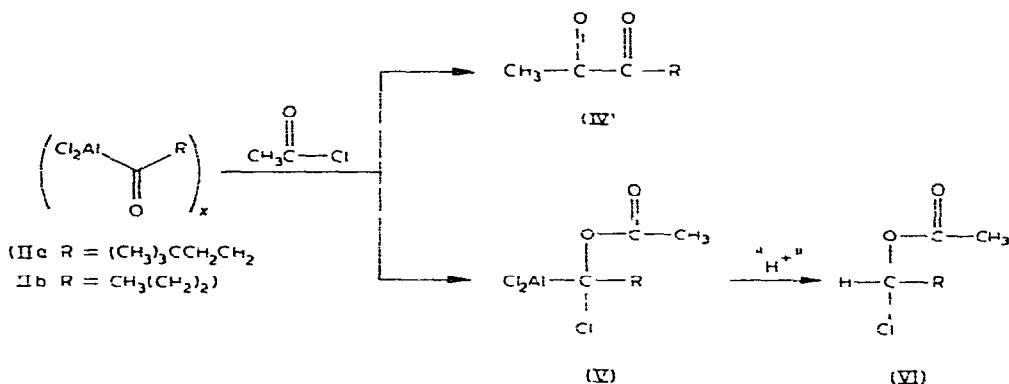

on hydrolysis gives VI (32%***). D_2O workup also gives VI but which is only 20% d_1 (as shown by NMR) Apparently, therefore, V is sufficiently basic to abstract proton from the reaction medium before workup Lewis acids, for example, aluminum chloride, are known to catalyze the reaction between aldehydes and acetyl chloride to produce α -chloroacetates such as VI [6] However, it is evident from NMR spectral analysis of unhydrolyzed reaction mixtures that treatment of II with acetyl chloride proceeds to give V (and VI) before hydrolysis. That VI is not formed during workup is further substantiated by the observation that added aldehyde survives under the reaction and workup conditions described herein*.

An attempt was made to transmetalate Ib and diisobutylaluminum chloride at room temperature in CH_2Cl_2 . Unfortunately, no transmetalation reaction occurred, instead, the two species formed a weak complex (as evidenced by NMR) which was readily dissociated by ether.

*Decarbonylation of $[\text{Cl}_2\text{AlC}(\text{O})\text{R}]_x$ produces Cl_2AlR which reacts with trace amounts of benzene present with the starting acylaluminum to give the alkylbenzene.

**Identified by NMR and mass spectral data.

***Characterized by ^1H and ^{13}C NMR, infrared and mass spectra.

*Also obtained in small amounts from this reaction are, in the case of IIa, 2,2,8,8-tetramethyl-5-nonanone and *neo*-hexylbenzene (both decarbonylation-derived products) and 4,4-dimethylpentanaldehyde (by hydrolysis of unreacted IIa). In the case of IIb the corresponding side products, propylbenzene and butyraldehyde, were also obtained.

The results described above provide evidence that it is indeed possible to prepare acylmetallic derivatives of a main group element from acyl-transition metals by transmetalation. These aluminum species are reactive toward standard electrophiles both at the carbon and oxygen atoms of the carbonyl group. We are now studying the preparation of acyl-main group metals by transmetalation to other main group metals in order to prepare acylmetallics which react with electrophiles specifically at carbon.

Acknowledgements

The authors acknowledge generous support for this research given by the National Science Foundation (CHE 76-02130). One of us (D.B.C.) acknowledges support as a National Cancer Institute Trainee (1976-7).

References

- 1 (a) O W Lever, Jr, *Tetrahedron*, 32 (1976) 1943, (b) A G Brook, *J Amer Chem Soc* 79 (1957) 4373.
- 2 (a) J P. Collman, *Accounts Chem. Res*, 8 (1975) 342 (b) Y Sawa, M Ryang and S Tsutsumi, *J Org. Chem*, 35 (1970) 4183; *Tetrahedron Lett*, (1969) 5189 (c) C A. Bertelo and J Schwartz, *J. Amer. Chem. Soc.*, 97 (1975) 228.
- 3 D B. Carr and J. Schwartz, *J. Amer. Chem. Soc.*, 99 (1977) 638
- 4 G Fachinetti, C Florani, F Marchetti and S Merlino *J Chem Soc, Chem Commun.*, (1976) 522
- 5 R R Arndt and C. Djerassi, *J Chem Soc, Chem. Commun.*, (1965) 578
- 6 R Kyburz, H. Schaltegger and M. Neuenschwander, *Helv Chim. Acta*, 54 (1971) 1037