

Journal of Organometallic Chemistry, 194 (1980) 229-256
© Elsevier Sequoia S.A., Lausanne -- Printed in The Netherlands

Bridged Ferrocenes. VI. * Hydrogenation with Pd/C Catalyst

Manny Hillman, ** Barry Gordon, Nan Dudek, Ruby Fajer, Etsuko Fujita,
Jeffrey Gaffney, Phelesia Jones, Allen J. Weiss

Division of Chemical Sciences, Department of Energy and Environment
Brookhaven National Laboratory

Upton, N.Y. 11973

and Shozo Takagi[@]

Department of Chemistry, Brookhaven National Laboratory

(Received January 7th, 1980)

Summary

The method of Van Meurs et al. [1] for hydrogenation of ferrocene has been extended to include a variety of bridged ferrocenes. Singly bridged and dibridged ferrocenes containing tri-, tetra-, or pentamethylene bridges were hydrogenated to the corresponding polycyclic hydrocarbons. Conditions required were consistent with a mechanism that involves an initial protonation of the iron atom. Bridge opening to a propylferrocene derivative was observed for the compound with three not-all-adjacent

* For Part V see Ref. 20

** To whom requests for information should be sent.

@ Present address: American Dental Association, Health Foundation
Research Unit, NBS, Washington, D.C. 20234

trimethylene bridges, and no hydrogenation reaction was observed for the corresponding derivative with tetramethylene bridges. Without catalyst or hydrogen, trifluoroacetylation and a rearrangement of a bridge were observed in the tris(trimethylene) compound. In the presence of catalyst but no hydrogen, an alpha alcohol and the corresponding diferrocenyl ether were obtained. Possible mechanisms are suggested for these reactions.

Introduction

The first successful hydrogenation of the cyclopentadienyl rings of ferrocene [7] used a Raney Nickel catalyst and hexane as solvent at 340° C and 280 atmospheres. Conditions under which benzene is hydrogenated with ease, such as with rhodium as catalyst and methanol as solvent, were markedly unsuccessful [2-6]. Recently, Van Meurs and coworkers [1] reported that ferrocene was hydrogenated in a few minutes at room temperature and under one atmosphere of hydrogen using palladium on carbon as catalyst and a number of acids as solvents. Their explanation of these remarkably simple hydrogenation conditions was that the iron species formed during the hydrogenation poisoned the catalyst, but under acid conditions the solvent removed the iron from the catalyst surface allowing the hydrogenation to continue. While their explanation appears reasonable, it does not tell why, according to our own observations, the hydrogenation could not be effected under similar conditions using platinum, rhodium or ruthenium as catalysts. They also reported results on hydrogenation of some derivatives of ferrocene and suggested that there were both steric and electronic effects on the rates. In this paper we report an investigation of this method. The results elaborate further on the steric effects, and a mechanism is proposed.

Results

The results of the hydrogenation of (see Figs. 1 and 2 for the structures) Ia,b,c, IIa,b, and IIIa,b are listed in Table 1. The yields listed are the percents of the introduced ferrocene that were isolated as hydrocarbons. The conditions investigated that affect the rate of hydrogenation are temperature, nature of solvent and the amount of catalyst. All of the compounds listed have fewer than three bridges and were successfully hydrogenated to some extent under the conditions given. Except for Ib, the relative ease of hydrogenation of these compounds is

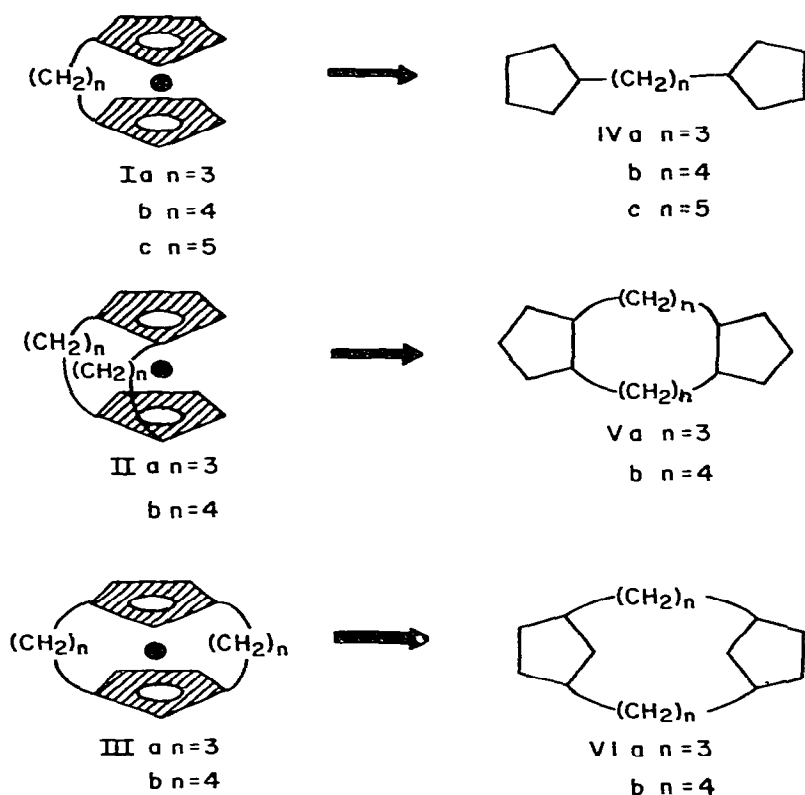
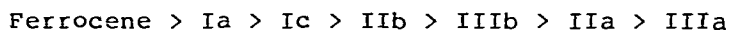

Fig. 1. Reactions investigated. The black circles represent the iron atoms.

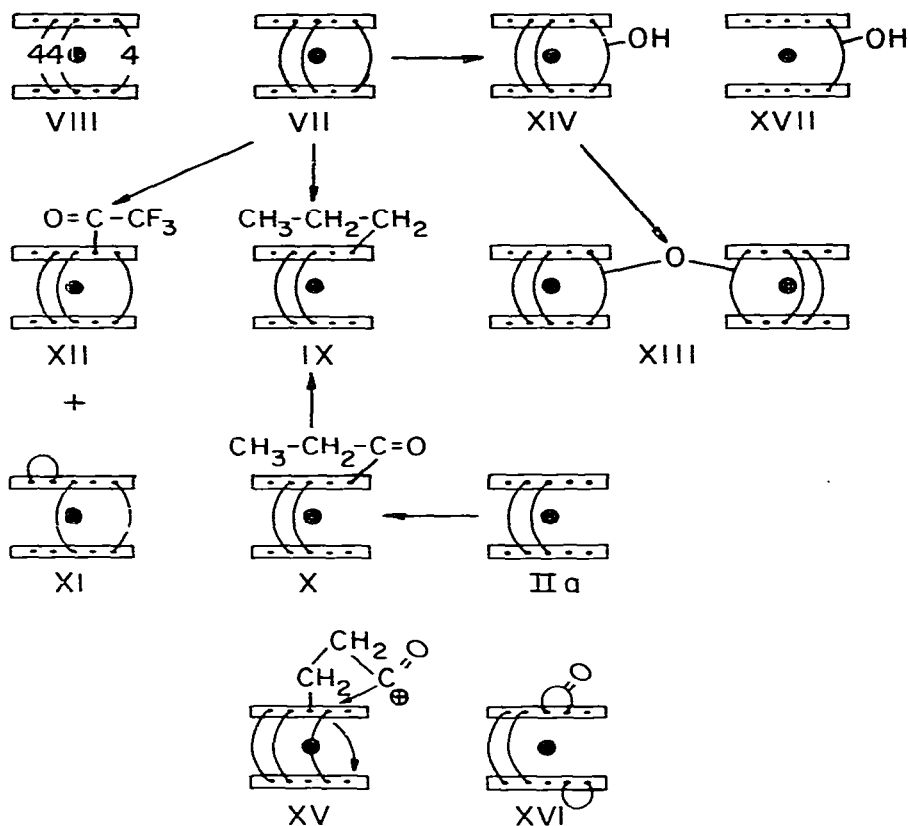

Fig. 2. Ferrocene derivatives and reactions. In each case the rectangles represent the cyclopentadienyl rings, the small solid circles the carbon atoms of the ring, the larger circles the iron atoms, and the arcs the bridges. The values in the arcs are the numbers of methylene groups in the bridges. The unlabeled arcs are trimethylene bridges.

The justification for this ordering follows: Ferrocene, Ia, Ib, and Ic could be hydrogenated at room temperature in acetic acid, the mildest conditions studied. For three of these compounds the relative pseudo zero order rate constants in Torr min⁻¹ are: ferrocene, 1.7; Ia, 0.26; Ic, 0.12. Though probably near Ia and

Table 1. The Conditions and Yields of the Hydrogenation Reactions

| Comp. | Solvent | °C | Hours | Torr ^a | Pd/C ^b | Yield ^c |
|-------|---------|------|-------|-------------------|-------------------|--------------------|
| Ia | A | room | 18 | 1250 | 1.18 | 96 |
| Ib | A | room | 18 | 1250 | 1.04 | 96 |
| Ic | A | room | 17 | 1250 | 1.02 | 98 |
| IIa | P | 141 | 20 | 1250 | 1.03 | 8 |
| | T | room | 20 | 1250 | 1.03 | 4 |
| | T | 70 | 23 | 1250 | 1.02 | 13 |
| | T | 70 | 19 | 1250 | 2.12 | 72 |
| IIb | A | room | 18 | 1250 | 1.00 | 5 |
| | A | 100 | 18 | 1250 | 1.00 | 92 |
| IIIa | A | 100 | 19 | 977 | 1.08 | 0 |
| | T | 70 | 19 | 1250 | 2.00 | 8 |
| IIIb | A | room | 18 | 1250 | 1.40 | 0 |
| | A | 100 | 18 | 1250 | 1.00 | 55 |

a) hydrogen pressure

b) mg catalyst per mg compound

c) mole percent of initial ferrocene obtained as hydrocarbon

A = acetic acid

P = propionic acid

T = trifluoroacetic acid

Ic, the proper position of Ib is not known and is not indicated. IIb gave a much lower yield than Ia,b,c at room temperature in acetic acid but a higher yield than IIIb in acetic acid at 100° C. IIa gave a lower yield in propionic acid at 141° C than IIIb in acetic acid at 100° C. Finally, the yield of IIIa in refluxing trifluoroacetic acid with twofold the usual amount of catalyst was lower than the yield of IIa under the same conditions.

The products of the hydrogenation reactions of Ia, Ib, and Ic were identified as the pure α,ω -biscyclopentylalkanes, IVa,

IVb, and IVc, respectively by means of GC/MS, IR and ^{13}C -NMR spectrometry. The products expected from IIa,b and IIIa,b are the tricycloalkanes, Va,b and VIa,b. The ^{13}C -NMR spectrum of Va, Vb and VIb indicated that mixtures of isomeric products had been formed with properties consistent with those expected. No ^{13}C -NMR spectrum of VIa was obtained because of the small amount of material available. GC/MS of the isomers of Va, Vb and VIb indicated that all but one of the components had the correct masses for the expected products (Fig. 3). Further analysis was not attempted.

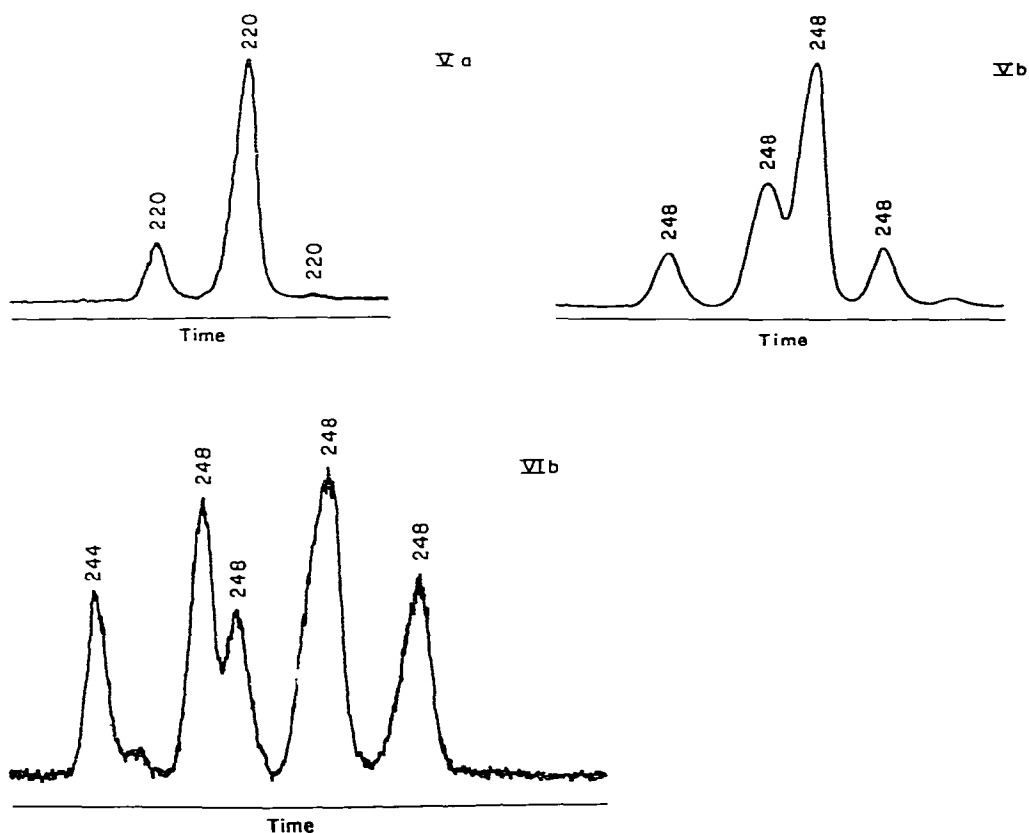

Fig. 3. The results of the GC/MS analysis. The numbers above the peaks are the parent peaks from the mass spectra.

Hydrogenation of tribridged ferrocenes presented a different problem. No reaction was observed for VII in acetic acid at 100° C at pressures up to 2000 psi. No hydrocarbon was obtained from VII in refluxing trifluoroacetic acid at one atmosphere. Instead, a single significant product was isolated which was identified by means of ¹³C-NMR as IX. This product was also isolated from hydrogenations in acetic acid at high temperatures and pressures (150° C, 2000 psi and 200° C, 150 psi). Independent synthesis of IX starting with IIa through X confirmed this identification. It is apparent that the scission of a bond of a trimethylene bridge to a ring had taken place in VII. In contrast to VII, VIII appears to be inert in trifluoroacetic acid.

Discussion

Catalytic hydrogenation of arenes on surfaces involves the absorption of and dissociation of hydrogen on the surface, absorption of the arene (probably through the π -orbitals) on the surface and transfer of the hydrogen to the arene. Homogeneous catalysis of hydrogenation of arenes involves a similar mechanism where the arene is complexed to the metal atom and hydrogen is transferred to the arene from the metal. Hydrogenation of ferrocene by this mechanism is inhibited since the π -orbitals are partially occupied and are not as available for reaction with the catalyst. We had found that ferrocene could not be hydrogenated with the homogeneous Muetterties [8] catalyst. Analogous to the mechanism of homogeneous hydrogenation, it would seem plausible that if hydrogen atoms would attach to the iron atom of ferrocene, then transfer to the cyclopentadienyl rings could occur. An attempt to demonstrate such autocatalysis succeeded for cobaltocene and nickelocene but not for ferrocene [9].

The difficulty in hydrogenation of ferrocene compared to benzene is, therefore, reasonable. That palladium on charcoal in

acid solvents can catalyze hydrogenation of ferrocene implies that a different mechanism is involved. We propose at this time that the mechanism for hydrogenation of ferrocene involves a reaction with the iron atom. The evidence is that the hydrogenation becomes more difficult with an increased number of bridges, which sterically makes the iron less available. Indeed, the hydrogenation of the rings of VII and VIII could not be effected. Furthermore, the isomers with the adjacent bridges are more easily hydrogenated than the isomers with the non-adjacent bridges in concordance with the greater space available for reaction with the iron atom in the derivatives with the adjacent bridges. Since the hydrogenation of the tetramethylene bridged derivatives is more easily effected than the hydrogenation of the derivatives with trimethylene bridges, the possibility that the decrease of the rate of hydrogenation from ferrocene to polybridged ferrocenes is due simply to alkyl substitution on the rings is ruled out. The tetramethylene bridges are potentially more flexible than the trimethylene bridges and can be arranged to allow greater availability of the iron.

Van Meurs et al. [1] suggested that the role of the acid was to remove iron-containing poisons from the surface of the catalyst. This role is not the rate determining step since the rate of hydrogenation depends on the ferrocene derivative. Furthermore, this cannot be the sole role of the acid since the rate of hydrogenation depends on the acid strength. We propose without further evidence that the role of the acid involves protonation of the iron followed by or concerted with a reaction with the catalyst. Protonation of the iron in ferrocene derivatives has been previously reported [10], and, of all of the bridged ferrocenes examined in this hydrogenation study, VII would not undergo protonation in HBF_3OH [10b] nor hydrogenation of the rings in trifluoroacetic acid.

There are two reaction sites on the ferrocene molecule for the catalyst. One is coordination with a ring carbon. Palladation of a ring carbon atom of some ferrocene derivatives has been observed [11,12]. Alternatively, the reaction of the catalyst may be through the iron. There is a vast literature in ferrocene chemistry concerning the participation of the iron atom in reactions, especially in the stabilization of carbonium ions [13], and coordination of the metal atoms in other metallocenes has been reported for intercalation with tantalum sulfide [14].

The failure of the hydrogenation of the rings of VII and VIII may be attributed to the failure of protonation, proper complexation with the catalyst, or both. To elucidate the possible mechanism of the bridge scission of VII, the stage at which the reaction occurred was investigated. One possibility was that the opening of the bridge to form the propyl group was instigated by the trifluoroacetic acid. The reaction of VII with trifluoroacetic acid without the addition of the Pd/C catalyst or of the hydrogen resulted in the formation of small amounts of two products, identified by x-ray crystallography as XI (Fig. 4) and XII (Fig. 5). XII is a Friedel-Crafts acylation product, and XI is the result of an acid catalyzed rearrangement of a bridge. The fact that the products have no apparent connection with the formation of IX and the fact that the yields of these two products were much lower than the yield of IX requires the conclusion that the formation of IX was not caused directly by the trifluoroacetic acid.

The mechanism of the bridge rearrangement may be similar to that observed in Ref. 15. In that work, it was suggested that the acylium ion attacks the ring carbon of the 4,4' bridge, as in XV, causing rearrangement of the 4,4' bridge to form the homoannular 4,5 trimethylene group in compound XVI. It was also

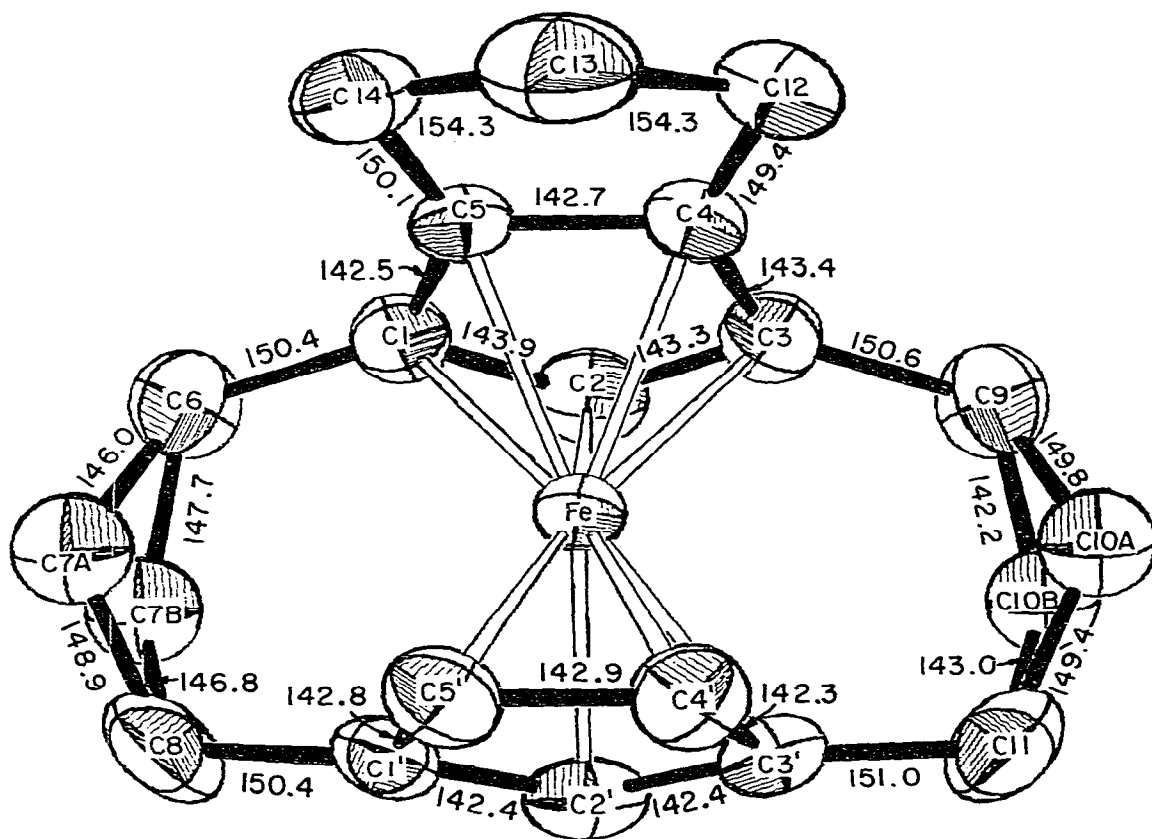

Fig. 4. The molecular structure of XI with the atoms represented by their 50% probability ellipsoids for thermal motion. The numbers are the bond lengths in pm ± 0.5 - 0.6 pm for distances between ordered atoms and ± 0.8 - 1.5 pm for distances including disordered atoms. Hydrogen atoms were omitted.

suggested that in a small fraction of the cases the attack was at the 2,2' bridge. In this case apparently the predominant if not all of the attack of the proton is at the ring carbon of the 2,2' bridge.

In the presence of Pd/C and trifluoroacetic acid, but without the hydrogen, two other products were isolated and iden-

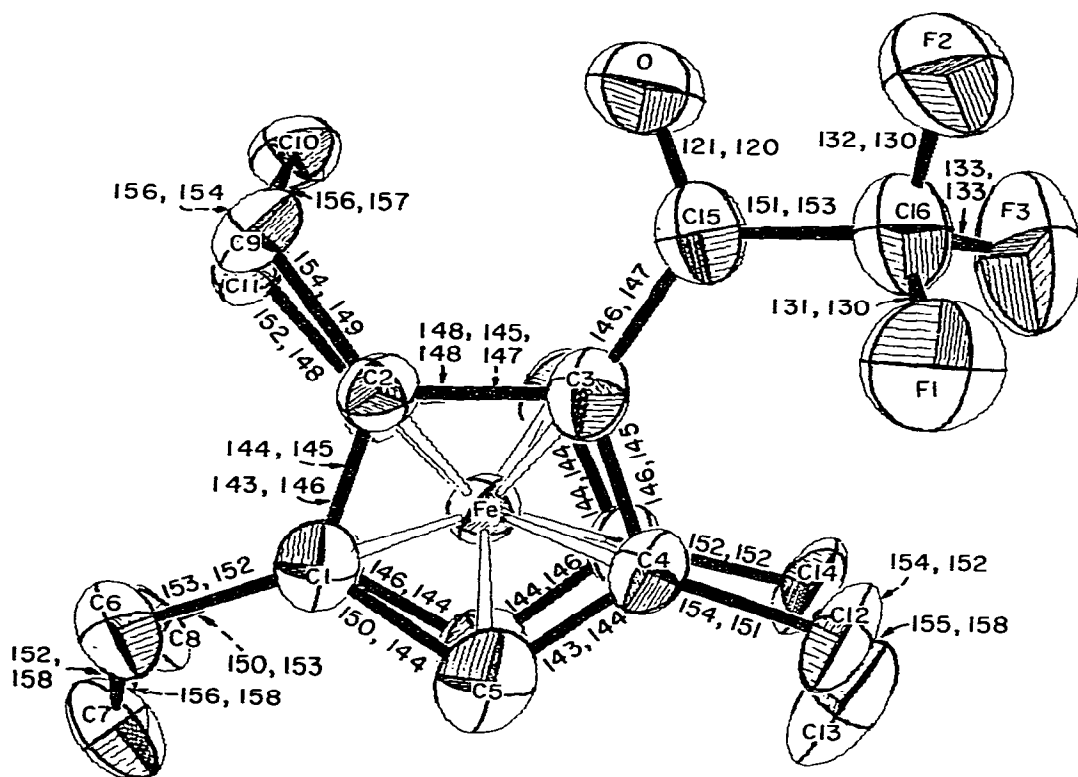

Fig. 5. The molecular structure of XII with the atoms represented by their 50% probability ellipsoids for thermal motion. The numbers are the bond lengths in pm $\pm 1-2$ pm.

tified as the ether, XIII, by x-ray crystallography (Fig. 6), and an alcohol, XIV, by its IR spectrum. By virtue of the fact that the alcohol was autoconverted to the ether, XIII, in the solid state at room temperature, the structure was assigned as XIV. XIV must have been the primary product of this reaction, although it in turn may have formed from the hydrolysis of an ester.

That the formation of the alcohol in the absence of hydrogen and the bridge scission in the presence of hydrogen involve the same bridge leads to the assumption that the mechanisms of the

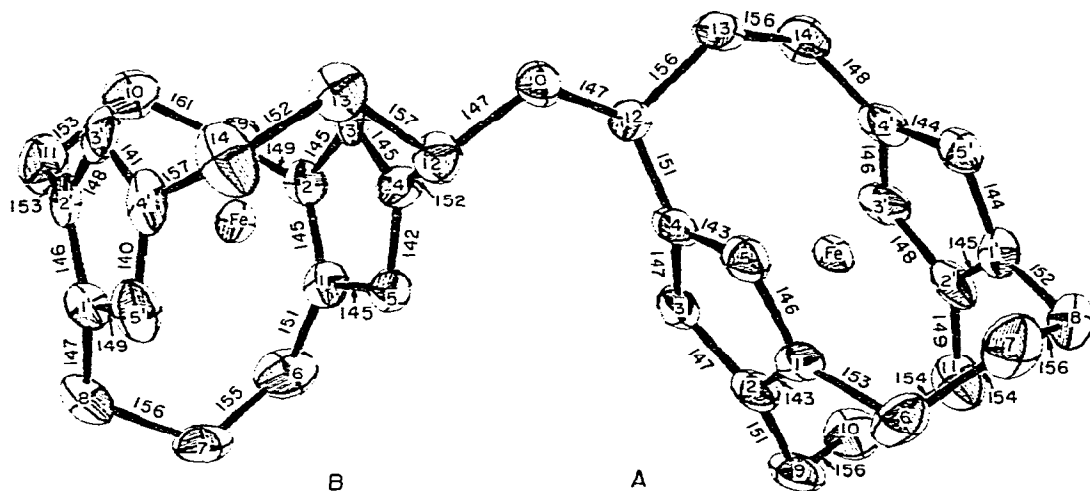

Fig. 6. The molecular structure of XIII with the atoms represented by their 50% probability ellipsoids for thermal motion. The numbers are the bond lengths in pm $\pm 1-2$ pm. The atoms designated only with numbers are carbon atoms.

two reactions are similar. A schematic diagram of a possible mechanism is illustrated in Fig. 7. The palladium coordinates with an appropriate ring carbon. In the presence of hydrogen, the hydrogen absorbed on the palladium transfers to the ring carbon and the alpha carbon of the bridge. In the absence of hydrogen, beta elimination transfers a hydride from the bridge to the palladium, and the trifluoroacetic acid reacts with the resulting carbonium ion.

The observation of bridge opening and the formation of the alpha hydroxyl derivative in VII are not merely the consequences of the absence of hydrogenation of the cyclopentadienyl rings since this situation does not obtain in VIII. These reactions are apparently caused by the effect introduced by the three short

HYDROGEN PRESENTHYDROGEN ABSENT

Fig. 7. Possible mechanism for the reaction of palladium with VII in the presence and absence of hydrogen.

bridges.* Evidence has been offered that there is a direct inductive effect by the iron atom on all of the methylene groups of the bridges particularly in the stabilization of carbonium ions [13,19]. The squeezing of the iron atom in VII increases the electron density and changes the electron gradient on the iron [20] and consequently increases the inductive effect.

The autoconversion in the solid state of the alcohol, XIV,

* The iron to ring distance of VII [16], is 7 pm shorter than the iron to ring distance of VIII [17] which in turn is 2 pm less than the iron to ring distance of ferrocene [18].

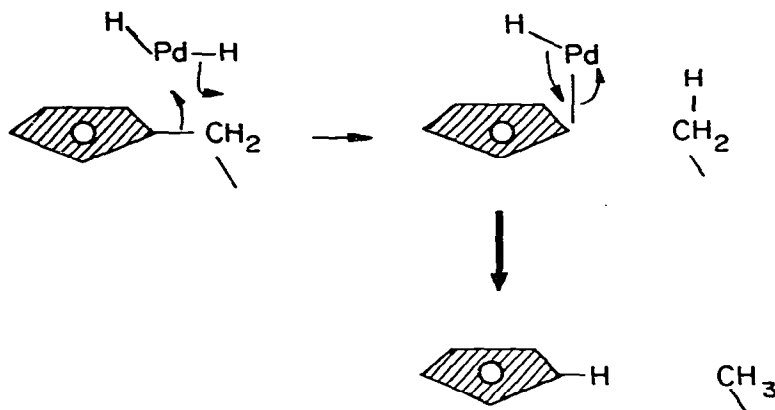
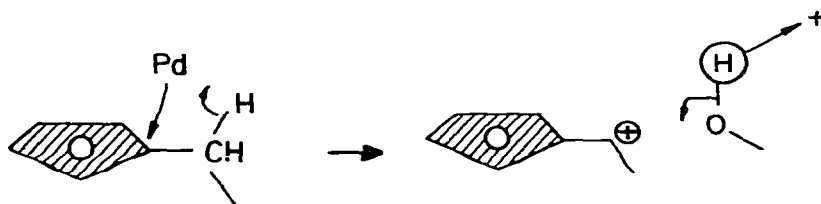
Table 2. Crystal Data

| | XI | XII | XIII |
|---|--|--|--|
| Molecular Formula | C ₁₉ H ₂₂ Fe | C ₂₁ H ₂₁ F ₃ FeO | C ₃₈ H ₄₀ Fe ₂ O |
| Molecular Weight | 306.232 | 402.239 | 624.431 |
| Space Group | C2/c | P $\bar{1}$ | P2 ₁ |
| a (pm) | 1673.0(2) | 822.8(2) | 1540.2(1) |
| b (pm) | 843.8(1) | 1381.0(3) | 789.5(1) |
| c (pm) | 2250.7(2) | 1539.1(3) | 1239.8(1) |
| α (°) | | 99.43(1) | |
| β (°) | 114.513(7) | 99.10(2) | 108.56(2) |
| γ (°) | | 90.29(2) | |
| V (nm ³) | 2.8908 | 1.7027 | 1.4291 |
| Z | 8 | 4 | 2 |
| ρ_{calc} (g/cm ³) | 1.408 | 1.574 | 1.452 |
| Crystal Dimensions ^a (mm) | d(0 $\bar{1}$ 1)=0.166 d(1 $\bar{1}$ 1)=0.156 d(1 $\bar{1}$ 1)=0.199 d(1 $\bar{1}$ 1)=0.148 d(10 $\bar{1}$)=0.038 d(10 $\bar{1}$)=0.102 d(1 $\bar{0}$ 0)=0.099 d(1 $\bar{0}$ 1)=0.096 d(010)=0.230 d(001)=0.039 | d(001)=0.281 d(010)=0.142 d(0 $\bar{1}$ 1)=0.320 d(1 $\bar{1}$ 0)=0.018 d(01 $\bar{1}$)=0.119 | d(010)=0.300 d(1 $\bar{2}$ 0)=0.234 d{001}=0.020 d{100}=0.119 |
| Abs. Coeff. (cm ⁻¹) | 82.6 | 74.8 | 80.0 |
| 2 θ range (°) | 2-140 | 2-140 | 1-140 |
| Reflections Collected | 7329 ^b | 5906 ^b | 7178 ^b |
| Reflections Used (Unique and I>3 σ) | 2052 ^c | 2623 ^b | 2389 ^c |
| Scan Width = A + B x tan ϵ | | | |
| A | 1.05 | 1.20 | 1.05 |
| B | 0.14 | 0.14 | 0.14 |
| R | 0.039 | 0.086 | 0.063 |
| R _w | 0.053 | 0.094 | 0.081 |
| Maximum Shift/Error Residual Electron | 0.5 | 0.5 | 0.2 |
| Density (e nm ⁻³) | 200 ^d | 500 ^e | 880 ^d |

- a distances of crystal planes from center of crystal
b hemisphere
c quadrant
d near an iron atom
e compared to 3000 e nm⁻³ for a typical carbon atom

to the ether, XIII, is another example of this type of activation. The hydroxyls of both XIV and XVII have strong intermolecular hydrogen bond interactions according to the IR spectra, but the alcohol, XVII, does not autoconvert to an ether. The enhanced reactivity of the hydroxyl of XIV is absent in XVII where the iron atom is not squeezed.

Experimental

Compounds Ia,b,c, IIa,b, IIIa,b, VII, and VIII were prepared according to procedures in the literature [21-26]. All bridged ferrocenes used in the experiment had been purified by chromatography and by recrystallization, checked by IR and by TLC. ^{13}C -NMR spectra were obtained on a Bruker WH-360 spectrometer. All chemical shifts of decoupled spectra are given in δ as ppm with coupled multiplicities in parentheses. Mass spectra and GLC separations were obtained on a computer controlled Hewlett Packard 5985A GC/MS using a column packed with 3% OV-17 supported on 120/140 GAS-CHROM Q (Applied Science Laboratories, Inc.). Where GC did not accompany MS, the sample was injected directly into the mass spectrometer through a heated inlet.

For the crystal structures, unit cell parameters and orientation matrices were automatically determined on an Enraf-Nonius CAD-4 diffractometer equipped with a graphite monochromator using $\text{Cu K}\alpha_1$ radiation ($\lambda=154.05$ pm). Intensity data were collected using θ - 2θ scans and $\text{Cu K}\bar{\alpha}$ radiation. The intensities were corrected for Lorentz, polarization and absorption effects [27]. Computations were performed using standard programs (ORFLS, ORFFE, FORDAP and ORTEPII) modified locally [27]. The scattering factors were taken from Doyle and Turner's tabulation [28] for all atoms except hydrogen. The scattering factors for iron were corrected for the real and

imaginary anomalous dispersion components using dispersion factors given by Cromer and Liberman [29]. Scattering factors for hydrogen were taken from values given by Stewart, Davidson and Simpson [30]. The agreement factors and least squares refinement are described in Ref. 16.

The structures were solved by the heavy atom method plus a full matrix least squares refinement. For compounds XII and XIII two blocks were used. Positions of the hydrogen atoms were calculated only for XI. Except for XIII, there were no unusual features encountered during the structural determination. For XIII, the space group $P2_1$ was initially assumed to explain several high peaks in the Patterson map and was subsequently confirmed by successful refinement. Since the compound crystallized in either the D or L optically active form, refinement with the coordinates (x,y,z) transformed to $(-x,-y,-z)$ was also carried out. The latter refinement was more successful than with the original coordinates, the R factor reduced, and peculiar iron to ring distances eliminated. (In the (x,y,z) refinement, the iron atoms were placed along the y axis 11 pm from the middle of the two cyclopentadienyl rings.) Final nonhydrogen atomic positional and thermal parameters for these compounds are given in Tables 3, 4, and 5. Hydrogen position coordinates for XI and tabulations of the final observed and calculated structure factors, interatomic distances, bond angles and least squares planes of the cyclopentadienyl rings were deposited in NAPS.* A summary of the crystallographic data is given in Table 2.

* These tables have been deposited as NAPS Document No. 03636 (52 pages). Order from ASIS/NAPS, c/o Microfiche Publications, P.O. Box 3513, Grand Central Station, New York, N.Y. 10017. A copy may be secured by citing the document number, remitting \$ 13.25 for photocopies or \$ 3.00 for microfiche. There is an additional \$ 3.00 mailing charge for persons outside of the U.S. Advance payment is required. Make checks payable to Microfiche Publications.

Table 3. Final Atomic Positional and Thermal Parameters^{a,b,c} for XI

| x | y | z | β_{11} | β_{12} | β_{33} | β_{12} | β_{13} | β_{23} |
|------|----------|----------|--------------|--------------|--------------|--------------|--------------|--------------|
| Fe | 17872(3) | 26960(5) | 12445(2) | 781(8) | 143(1) | 34(3) | 75(1) | 46(2) |
| C1 | 1460(2) | 1590(4) | 1900(2) | 125(6) | 21(1) | 12(2) | 14(1) | 20(2) |
| C2 | 2319(3) | 2294(5) | 2204(2) | 139(6) | 15(1) | 7(3) | 7(1) | 9(2) |
| C3 | 2869(2) | 1688(4) | 1909(2) | 126(6) | 18(1) | 5(2) | 5(1) | 16(2) |
| C4 | 2361(2) | 514(4) | 1446(2) | 94(5) | 23(1) | 12(2) | 11(1) | 12(2) |
| C5 | 1507(2) | 463(4) | 1444(2) | 87(5) | 25(1) | 4(2) | 12(1) | 16(2) |
| C1' | 893(2) | 4444(4) | 939(2) | 102(5) | 21(1) | 21(2) | 14(1) | 14(2) |
| C2' | 1759(3) | 5070(4) | 1255(2) | 85(5) | 21(1) | 4(3) | 15(1) | 2(2) |
| C3' | 2286(2) | 4518(4) | 937(2) | 93(5) | 23(1) | -3(2) | 13(1) | 10(2) |
| C4' | 1722(2) | 3607(5) | 392(2) | 136(6) | 16(1) | 9(3) | 15(1) | 9(2) |
| C5' | 869(2) | 3554(5) | 393(2) | 129(6) | 16(1) | 10(2) | 5(1) | 10(2) |
| C6 | 653(3) | 2127(6) | 1979(2) | 185(8) | 37(1) | 22(3) | 35(2) | 26(3) |
| C7A | -16(5) | 2990(10) | 1439(4) | * | | | | |
| C7B | 374(6) | 3791(12) | 1820(5) | ** | | | | |
| C8 | 176(3) | 4495(6) | 1177(2) | 50(2) | 35(1) | 49(3) | 26(1) | 21(3) |
| C9 | 3754(3) | 2328(5) | 2004(2) | 26(1) | 33(1) | -1(3) | 2(1) | 17(3) |
| C10A | 3794(4) | 3198(8) | 1437(3) | *** | | | | |
| C10B | 3800(9) | 3887(18) | 1780(7) | **** | | | | |
| C11 | 3270(3) | 4674(6) | 1182(2) | 45(2) | 36(1) | -23(3) | 18(1) | 11(3) |
| C12 | 2431(3) | -674(5) | 977(2) | 49(2) | 33(1) | 17(3) | 20(1) | 5(2) |
| C13 | 1459(3) | -1051(5) | 541(2) | 65(3) | 34(1) | -2(3) | 15(2) | -6(2) |
| C14 | 946(3) | -748(5) | 963(2) | 44(2) | 36(1) | -7(3) | 11(1) | 5(2) |

a The form of the thermal ellipsoid expression is

$$\exp[-\beta_{11}h^2 - \beta_{22}k^2 - \beta_{33}l^2 - 2\beta_{12}hk - 2\beta_{13}hl - 2\beta_{23}kl]$$

Isotropic thermal factors were used for C7A, C7B, C10A, and C10B.

b Occupancy factors for C7A and C7B are 0.56(1) and 0.46(1), respectively. The factors for C10A and C10B are 0.67(1) and 0.32(1), respectively.

c The values for Fe have been multiplied by 10^5 . Except for the four below, the values for the other atoms have been multiplied by 10^4 .

* B = 0.045(1) nm²

** B = 0.046(2) nm²

*** B = 0.041(1) nm²

**** B = 0.047(3) nm²

Table 4. Final Positional and Thermal Parameters^{a,b} for XII

| Unit | A | x | Y | Z | β_{11} | β_{12} | β_{33} | β_{12} | β_{13} | β_{23} |
|------|----------|-----------|---------|---------|--------------|--------------|--------------|--------------|--------------|--------------|
| Fe | 3654(2) | -1114(1) | 1707(1) | 113(3) | 39(1) | 28(1) | 3(1) | 3(1) | 3(1) | 4(1) |
| Cl1 | 3860(13) | -2563(6) | 1539(6) | 174(22) | 35(6) | 30(5) | 9(9) | 9(9) | 5(9) | 10(5) |
| C2 | 2209(11) | -2276(7) | 1588(6) | 114(19) | 45(6) | 27(5) | -1(9) | -1(9) | 6(8) | 7(5) |
| C3 | 2237(13) | -1651(7) | 2470(6) | 158(22) | 48(7) | 31(5) | -8(10) | -8(10) | 16(9) | 3(5) |
| C4 | 3949(13) | -1510(7) | 2909(6) | 151(22) | 61(8) | 27(5) | 8(10) | 8(10) | -2(9) | 0(5) |
| C5 | 4963(14) | -2089(7) | 2373(6) | 236(26) | 43(7) | 37(6) | 23(11) | 23(11) | -7(10) | 22(5) |
| Cl1' | 4493(12) | -835(7) | 603(6) | 135(20) | 49(7) | 37(5) | 37(5) | -7(9) | 18(9) | 5(5) |
| C2' | 2811(12) | -564(6) | 608(6) | 156(20) | 33(6) | 30(5) | 13(9) | 13(9) | 15(8) | 8(5) |
| C3' | 2743(13) | 161(6) | 1400(6) | 171(21) | 30(6) | 32(5) | -6(9) | -6(9) | -13(9) | 2(4) |
| C4' | 4370(12) | 304(7) | 1914(6) | 153(21) | 37(6) | 35(5) | -10(9) | -10(9) | 8(9) | 3(5) |
| C5' | 5453(13) | -282(8) | 1412(6) | 147(22) | 65(8) | 40(6) | -10(11) | -10(11) | 9(9) | 12(6) |
| C6 | 4508(14) | -3108(7) | 722(7) | 188(24) | 56(8) | 45(6) | 13(11) | 13(11) | 35(10) | -1(6) |
| C7 | 5793(14) | -2521(7) | 407(7) | 219(25) | 41(7) | 61(7) | 28(11) | 28(11) | 55(11) | 14(6) |
| C8 | 5131(13) | -1631(7) | -32(7) | 188(23) | 62(8) | 47(6) | 40(11) | 40(11) | 53(10) | 6(6) |
| C9 | 705(12) | -2490(8) | 847(6) | 131(20) | 68(8) | 35(5) | -10(11) | -10(11) | -13(9) | -3(6) |
| C10 | 87(12) | -1562(7) | 450(6) | 120(18) | 64(8) | 36(5) | 10(10) | 10(10) | -2(8) | 11(5) |
| C11 | 1345(13) | -1081(7) | -28(6) | 157(20) | 56(7) | 29(5) | 9(10) | 9(10) | -13(9) | 1(5) |
| C12 | 4674(14) | -721(8) | 3704(6) | 222(28) | 74(9) | 26(5) | -43(13) | -43(13) | -11(10) | -5(6) |
| C13 | 5687(18) | 112(10) | 3463(8) | 339(36) | 87(11) | 52(8) | -35(16) | -35(16) | -49(14) | 2(8) |
| C14 | 4796(14) | 812(8) | 2878(7) | 222(27) | 67(9) | 35(6) | -20(12) | -20(12) | -25(10) | -15(6) |
| C15 | 726(14) | -1346(7) | 2804(7) | 190(25) | 54(8) | 39(6) | 5(11) | 5(11) | 25(10) | 7(6) |
| C16 | 672(17) | -1137(10) | 3791(8) | 245(32) | 103(13) | 41(7) | 13(12) | 13(12) | 31(8) | 5(8) |
| O | -610(10) | -1310(7) | 2349(5) | 173(18) | 191(11) | 42(4) | 53(12) | 53(12) | 15(8) | 14(6) |
| F1 | 1717(10) | -1639(7) | 4261(4) | 294(20) | 205(10) | 46(4) | 29(11) | 29(11) | 30(7) | 51(5) |
| F2 | -803(10) | -1357(7) | 3947(4) | 259(19) | 193(9) | 58(5) | 21(11) | 21(11) | 52(8) | 22(5) |
| F3 | 969(12) | -190(7) | 4113(5) | 496(29) | 132(8) | 89(6) | 38(12) | 38(12) | 40(10) | -47(6) |

a The form of the anisotropic thermal ellipsoid expression is

$$\exp[-\beta_{11}h^2 - \beta_{22}k^2 - \beta_{33}l^2 - 2\beta_{12}hk - 2\beta_{13}hl - 2\beta_{23}kl]$$

b The values have been multiplied by 10^4 .

| Unit | X | Y | Z | β_{11} | β_{22} | β_{33} | β_{12} | β_{13} | β_{23} |
|------|-----------|----------|---------|--------------|--------------|--------------|--------------|--------------|--------------|
| Fe | 218(2) | 3890(1) | 2757(1) | 140(3) | 45(1) | 27(1) | 9(1) | -4(1) | -9(1) |
| C1 | 133(13) | 5259(7) | 3406(6) | 203(24) | 39(7) | 25(5) | 16(10) | 5(9) | -13(5) |
| C2 | 1794(13) | 4985(7) | 3274(6) | 172(22) | 46(7) | 28(5) | -8(10) | -6(9) | 2(5) |
| C3 | 2155(12) | 4131(7) | 3729(6) | 115(19) | 58(7) | 26(5) | 7(9) | -9(8) | -2(5) |
| C4 | 693(14) | 3852(7) | 4059(6) | 223(25) | 46(7) | 21(5) | -6(11) | -3(9) | -3(5) |
| C5 | -509(14) | 4583(7) | 3896(6) | 223(25) | 50(7) | 23(5) | 18(11) | -1(9) | -14(5) |
| C1' | -1308(13) | 3976(8) | 1614(6) | 132(20) | 77(9) | 24(5) | 4(11) | -6(8) | -21(5) |
| C2' | 351(13) | 3743(8) | 1455(6) | 176(24) | 69(8) | 27(5) | -4(11) | 13(9) | -4(6) |
| C3' | 746(13) | 2821(7) | 1793(6) | 195(24) | 48(7) | 23(5) | -14(10) | -2(9) | -20(5) |
| C4' | -604(14) | 2533(8) | 2191(6) | 192(25) | 55(8) | 35(6) | 3(11) | 2(10) | -15(5) |
| C5' | -1902(13) | 3231(8) | 2054(7) | 162(23) | 70(9) | 38(6) | -16(12) | -3(10) | -20(6) |
| C6 | -862(16) | 6028(8) | 2970(7) | 275(33) | 60(9) | 54(7) | 61(14) | -5(13) | -2(6) |
| C7 | -2512(15) | 5547(9) | 2388(7) | 240(29) | 84(10) | 50(7) | 74(14) | -23(11) | -23(7) |
| C8 | -2209(16) | 4921(9) | 1476(7) | 274(31) | 87(10) | 51(7) | 81(14) | -57(12) | -13(7) |
| C9 | 2855(14) | 5395(7) | 2716(7) | 220(25) | 50(8) | 43(6) | -22(11) | 26(10) | -3(6) |
| C10 | 3067(16) | 4723(10) | 1820(7) | 226(28) | 116(12) | 42(6) | -20(15) | 14(11) | 4(7) |
| C11 | 1512(15) | 4374(9) | 1140(7) | 220(30) | 99(10) | 45(7) | -2(14) | 31(12) | 7(7) |
| C12 | 375(15) | 2893(9) | 4366(7) | 231(28) | 75(10) | 53(7) | -35(13) | -7(11) | 24(7) |
| C13 | -966(21) | 2191(10) | 3710(8) | 521(49) | 78(11) | 55(8) | -63(19) | 18(16) | 5(8) |
| C14 | -549(17) | 1766(8) | 2800(8) | 349(38) | 60(9) | 59(8) | -20(14) | 53(14) | 8(7) |
| C15 | 3798(13) | 3715(8) | 3850(7) | 142(22) | 74(9) | 40(6) | 5(11) | -1(10) | 9(6) |
| C16 | 4487(15) | 3432(9) | 4753(8) | 199(29) | 76(10) | 60(8) | 23(14) | -19(12) | 10(8) |
| O | 4771(10) | 3674(7) | 3344(5) | 194(19) | 165(10) | 68(6) | 62(11) | 35(9) | 43(6) |
| F1 | 3733(10) | 3785(6) | 5411(5) | 352(21) | 182(9) | 33(4) | 83(11) | 4(7) | -1(5) |
| F2 | 4440(12) | 2480(6) | 4691(5) | 612(33) | 103(7) | 88(6) | 94(13) | -7(11) | 42(6) |
| F3 | 6072(10) | 3684(8) | 4982(5) | 243(20) | 241(12) | 72(5) | -1(13) | -50(8) | 18(6) |

a The form of the thermal ellipsoid expression is

$$\exp[-\beta_1 h^2 - \beta_2 k^2 - \beta_3 l^2 - 2\beta_{12} h k - 2\beta_{13} h l - 2\beta_{23} k l]$$

b The values have been multiplied by 10^4 .

Table 5. Final Atomic Positional and Thermal Parameters^{a,b} for XIII

| | x | y | z | β_{11} | β_{22} | β_{33} | β_{12} | β_{13} | β_{23} |
|------|----------|-----------|-----------|--------------|--------------|--------------|--------------|--------------|--------------|
| FeA | -477(1) | -200 | 2653(1) | 30(1) | 782(2) | 27(1) | -2(1) | 9(1) | -6(1) |
| FeB | -4080(1) | -2900(3) | -2146(1) | 27(1) | 903(3) | 42(1) | -12(1) | 9(1) | -13(2) |
| O | -2740(5) | -3742(9) | 1386(5) | 42(1) | 121(13) | 40(5) | -23(6) | 11(4) | -8(7) |
| C1A | -183(6) | -1696(12) | 1921(8) | 31(5) | 68(15) | 49(7) | 0(7) | 20(5) | -23(9) |
| C2A | -165(6) | -273(14) | 1203(7) | 47(2) | 102(17) | 40(6) | -16(9) | 21(5) | -22(10) |
| C3A | -1162(6) | -253(15) | 962(7) | 40(3) | 146(20) | 29(5) | -16(10) | 9(4) | -15(9) |
| C4A | -1396(6) | -1682(13) | 1573(7) | 40(5) | 107(18) | 33(6) | -11(8) | 15(5) | -18(10) |
| C5A | -580(6) | -2615(14) | 2107(7) | 42(5) | 106(19) | 42(6) | -12(9) | 10(5) | -18(10) |
| C1'A | 503(6) | 407(13) | 4070(8) | 35(5) | 107(18) | 44(7) | -1(8) | 15(5) | 5(9) |
| C2'A | 172(7) | 1904(13) | 3388(7) | 59(6) | 97(19) | 34(6) | -10(9) | 13(5) | -18(9) |
| C3'A | -821(7) | 2011(15) | 3230(8) | 49(5) | 127(20) | 49(7) | 1(10) | 28(5) | -29(11) |
| C4'A | -1058(7) | 543(15) | 3793(8) | 47(6) | 143(20) | 41(7) | 2(9) | 25(5) | -26(10) |
| C5'A | -1058(7) | -380(14) | 4364(7) | 36(5) | 147(22) | 36(6) | 1(9) | 12(5) | -20(10) |
| C6A | 1195(6) | -2122(15) | 2501(10) | 26(5) | 173(25) | 87(10) | 9(9) | 15(6) | -20(11) |
| C7A | 1465(7) | -2113(17) | 3812(10) | 37(6) | 197(26) | 93(11) | 17(11) | 14(6) | -25(13) |
| C8A | 1482(6) | -317(17) | 4343(8) | 34(5) | 144(22) | 54(7) | -10(11) | 15(6) | -16(13) |
| C9A | 378(7) | 1164(15) | 934(8) | 56(9) | 144(22) | 50(8) | -25(10) | 5(5) | -3(3) |
| C10A | 264(8) | 2913(16) | 1462(10) | 64(7) | 152(24) | 74(10) | -22(12) | 32(7) | 8(13) |
| C11A | 662(8) | 2970(15) | 2771(10) | 66(7) | 116(21) | 67(9) | -37(10) | 17(7) | -16(12) |
| C12A | -231(7) | -1808(14) | 1778(8) | 34(5) | 133(18) | 46(7) | -22(8) | 15(5) | -17(10) |
| C13A | -2010(7) | -1783(18) | 3053(9) | 56(7) | 231(30) | 55(8) | -62(13) | 33(7) | -48(14) |
| C14A | -2010(7) | -8(19) | 3617(8) | 42(5) | 210(26) | 63(8) | -3(12) | 27(6) | -49(15) |
| C1B | -4457(7) | -611(11) | -1751(8) | 41(6) | 60(16) | 55(8) | -11(7) | 11(5) | -28(8) |
| C2B | -3663(7) | -527(11) | -2146(8) | 40(5) | 58(17) | 55(8) | -11(7) | 8(5) | -5(8) |
| C3B | -2937(6) | -1534(13) | -1370(8) | 29(5) | 107(18) | 43(7) | -12(8) | 16(5) | -11(10) |
| C4B | -4228(6) | -2313(13) | -572(8) | 32(5) | 109(18) | 54(7) | -14(8) | 16(5) | -24(10) |
| C5B | -4228(6) | -1700(12) | -756(8) | 33(5) | 73(18) | 43(7) | -11(8) | 7(6) | -28(11) |
| C1'B | 5201(7) | -3573(15) | -3450(9) | 44(5) | 157(22) | 50(8) | -41(10) | 16(5) | -27(10) |
| C2'B | 4380(7) | -3544(15) | -3792(8) | 39(5) | 131(21) | 45(7) | -11(9) | 16(5) | -27(10) |
| C3'B | 3695(7) | -4722(14) | -3058(8) | 43(5) | 119(21) | 55(7) | -14(9) | 9(5) | -37(9) |
| C4'B | 4092(8) | -5396(12) | -2266(9) | 63(7) | 48(17) | 61(8) | -29(12) | 8(5) | -28(10) |
| C5'B | 4991(7) | -4803(13) | -2494(8) | 49(6) | 97(20) | 53(7) | -4(9) | 5(5) | -20(10) |
| C6B | 5400(7) | 77(18) | -2343(10) | 22(5) | 190(26) | 89(9) | 22(10) | 12(6) | -30(12) |
| C7B | -6136(7) | -1302(20) | -2815(11) | 28(5) | 281(36) | 89(12) | -2(11) | 20(7) | -33(13) |
| C8B | 5972(7) | -2371(19) | -3789(9) | 28(5) | 251(33) | 70(9) | -11(10) | -4(6) | -16(11) |
| C9B | 3583(8) | 283(16) | -3193(10) | 56(7) | 149(25) | 85(10) | 11(11) | 28(7) | -24(15) |
| C10B | -3386(7) | -1053(15) | -4064(9) | 44(6) | 154(23) | 71(10) | -16(10) | 31(7) | 5(12) |
| C11B | -4156(8) | -2301(17) | -4611(8) | 55(6) | 208(28) | 49(7) | -15(11) | 18(6) | -7(19) |
| C12B | -2876(7) | -3791(13) | 180(8) | 40(5) | 96(18) | 37(7) | -12(8) | 9(5) | 2(9) |
| C13B | -3470(8) | -2445(12) | 148(9) | 64(7) | 52(18) | 68(9) | -2(8) | 20(7) | -5(11) |
| C14B | -3535(9) | -6339(15) | -1152(10) | 88(9) | 91(20) | 64(10) | -1(11) | 16(8) | -5(11) |

a The form of the thermal ellipsoid expression is $\exp[-\beta_{11}u^2 - \beta_{22}v^2 - \beta_{33}w^2 - 2\beta_{12}uv - 2\beta_{13}uw - 2\beta_{23}vw]$
 b The values have been multiplied by 10⁴.

Hydrogenations - General Procedure. Hydrogenation reactions were run using 100 mg of each of the bridged ferrocene compounds, 10% Pd/C catalyst, and 20 ml of solvent, either glacial acetic acid, propionic acid or trifluoroacetic acid. The reaction flask was placed in an oil bath sitting atop a hot plate-magnetic stirrer combination. A temperature controller allowed the oil bath to be held within $\pm 2^{\circ}$ C of the desired temperature. The entire system contained a 40 liter ballast tank which was pressured to about 1250 Torr with hydrogen, and the reaction was allowed to proceed overnight. After cooling, the reaction mixture was centrifuged, decanted, and the catalyst was washed with benzene. The solution was added to 40 ml of water. When acetic or propionic acid was the solvent, the solution was buffered with sodium acetate to bring the pH into the range where ascorbic acid would reduce any ferrocenium derivative that may have formed. When trifluoroacetic acid was the solvent, an excess of sodium acetate was required. After addition of ascorbic acid, the solution was extracted twice with benzene, and all benzene solutions were combined. After washing with water and 5% sodium bicarbonate solution, the benzene was dried over anhydrous sodium sulfate.

Hydrogenation of Ia,b,c, IIa,b, and IIIa,b. The product mixtures were separated on a silica gel column with hexane. The colorless fractions eluted before the yellow starting material were evaporated to yield the hydrogenation product as a colorless liquid. Blank yields were about 2 mg, and yields equal to or below that were considered as zero. The yellow material eluted subsequently from the column was identified as starting material by means of TLC and the IR spectra. The products, IVa,b,c, Va,b, and VIa,b were identified as follows: IVa, m/e 180, single component in GC, IR identical to that in the literature [31], $^{13}\text{C-NMR}$, 40.7(d) [CH of cyclopentyl rings], 37.0(t),

33.2(t), 28.4(t), 25.7(t) [CH₂, two fourfold carbons of cyclopentyl rings, one twofold carbon of propano group, and central carbon of propano group]: IVb, m/e 194, single component in GC, IR identical to that in literature [31], ¹³C-NMR, 40.9(d) [CH of cyclopentyl rings], 37.0(t), 33.4(t), 29.8(t), 25.9(t) [CH₂, two fourfold carbons of cyclopentyl rings, two twofold carbons of butano group]: IVc, m/e 194, single component in GC, IR identical to that in literature [31]: Va, m/e (see Fig. 3), IR of saturated hydrocarbon, ¹³C-NMR, major peaks - 40.6(d) [CH], 34.1(t), 32.9(t), 32.8(t), 32.2(t), 22.9(t), 21.9(t) [CH₂], 22 peaks with intensities .1 < I < .3 of average of the major peaks, 12 peaks with intensities .05 < I < .1 of average of the major peaks: Vb, m/e (see Fig. 3), IR of saturated hydrocarbon: VIA, IR of saturated hydrocarbon: VIB, m/e (see Fig. 3), IR of saturated hydrocarbon, ¹³C-NMR, (coupled spectrum too complex to determine multiplicities) = 42.4, 41.6, 41.4, 40.4, 40.2, 39.8, 39.5, 39.0, 37.8, 36.8, 36.5, 36.4, 35.7, 35.6, 35.4, 35.1, 34.9, 34.6, 32.8, 32.0, 31.0, 30.3, 30.2, 28.8, 28.1, 26.7, 26.5, 24.9, 23.8.

Measurement of Rates of Hydrogenation. For these experiments, the sample and acetic acid were flushed with nitrogen and hydrogen while kept in a dropping funnel. The flask containing the catalyst was also flushed and pressured with one atmosphere of hydrogen. The solution was then added at once and the stirrer started. The temperature was controlled to 24±2° C. The ballast tank was not used, and the total volume was thus kept small, but large enough that the hydrogen pressure change measured was less than 10% of the total hydrogen pressure.

Hydrogenation of VII at High Temperatures and Pressures. An Autoclave Engineers Inc. WP-5000 high pressure apparatus was used. 100 mg of VII, 100 mg of Pd/C catalyst and 50 ml of acetic acid were pressured with hydrogen under these different conditions: 1) 2000 psi, 100° C, 2.5 days; 94 mg of VII was

recovered; 2) 350 psi, 200° C, overnight; 74 mg of a yellow oil was obtained which, after chromatography, had an IR spectrum identical to IX. No VII was recovered. 3) 2000 psi, 150° C, overnight; 85 mg of IX was obtained. No VII was recovered.

Hydrogenation of VII. To 100 mg of VII and 200 mg of 10% Pd/C catalyst in 20 ml of trifluoroacetic acid, pressured to about 1250 Torr of hydrogen were refluxed overnight with stirring. The reaction mixture was treated as above, and the residue was chromatographed on a silica gel column. Elution with hexane gave about a 50% yield of IX as an oil, f.p. above 0° C; ¹³C-NMR, 89.4(s), 85.3(s), 85.1(s) [1,1',2,2', and 4 ring carbons], 69.9(d), 68.8(d) [3,3', and 4' ring carbons], 38.4(t) [α bridge carbons], 34.0(t), 28.1(t) [α and β propyl carbons], 24.5(t) and 24.3(t) [β bridge carbons], 18.2(q) [γ propyl carbon (methyl group)]. Further elution with hexane and benzene gave a 22% recovery of VII. In this and most other experiments with VII and VIII below, subsequent elution with ethyl acetate gave varying amounts of a material that appeared to have carbonyl groups according to the IR spectra and to consist of several components according to TLC. These were not investigated further.

Propionylation of IIa. 99.7 mg of IIa were treated with propionic anhydride and BF₃·(C₂H₅)₂O in methylene chloride according to the procedure of Vigo [22] for the acetylation of IIa. The product mixture was chromatographed on silica gel. The first component, eluted with benzene was 45.2 mg of IIa. The second component eluted with benzene was 21.8 mg of the 3-propionyl derivative of IIa, and the last component, eluted with 5% ethyl acetate in benzene, was 25.8 mg of X, the 4-propionyl derivative of IIa. Further purification or identification was not attempted.

Reduction of X to IX. The entire product above, X, was placed in a flask with 190 mg of PtO₂ catalyst and 20 ml of

glacial acetic acid. It was stirred overnight under 1250 Torr of hydrogen at room temperature. The acetic acid solution was diluted with 40 ml of water and buffered with sodium acetate. The sodium acetate solution was extracted with benzene, and the benzene solution was combined with benzene washings of the catalyst. The product was chromatographed on silica gel and eluted with hexane to give an oil with an IR spectrum identical to IX.

Reaction of VII with Trifluoroacetic Acid. The procedure was the same as in the hydrogenation reaction above except that the catalyst was omitted and the mixture was pressured with nitrogen instead of hydrogen. 96.6 mg of VII was used in the reaction. The crude product was chromatographed on a silica gel column. Elution with hexane gave at first 3.4 mg of a ferrocene colored solid, m.p. 164-165^o C, identified as XI (lit. m.p. 160.0-162.5^o C [32]) by x-ray crystallography* (Fig. 4) of a crystal of XI grown from hexane at -15^o C. Continued elution of the column with hexane gave recovered VII. Subsequent elution with benzene gave 11.6 mg of a red compound, m.p. 53-55^o C, identified as XII by x-ray crystallography** (Fig. 5) of a crystal grown by vapor diffusion of water into a solution of XII in ethanol.

* The middle carbons of the 1,1' and the 3,3' trimethylene bridges were found to be disordered and to occur as partial atoms, C7A and C7B of the 1,1' bridge and C10A and C10B of the 3,3' bridge with independent occupancy factors of 0.56(1) and 0.46(1) for C7, and 0.67(1) and 0.32(1) for C10 rather than the 0.5 ordinarily expected. The carbon-distances including disordered atoms appear to be too short. This may be due to the difficulty of the refinement for disordered atoms. The cyclopentadienyl rings are slightly nonplanar. It is of interest to note that the middle carbon atom of the homoannular ring is approximately 38 pm toward the iron atom from the plane of the cyclopentadienyl ring.

** Although the structural features are similar to those of VII, in XII the slightly shorter distance of the iron to the ring with the trifluoroacetyl substituent (156.4(3) pm) than of the iron to the ring without the substituent (159.0(2) pm) may be due to the electronic effect of the substituent.

Reaction of VII with Pd/C. The procedure was the same as in the hydrogenation reaction above except that the mixture was pressured with nitrogen instead of hydrogen. 303.8 mg of VII and 609.0 mg of Pd/C was used in the reaction. The crude product was chromatographed on a silica gel column. Elution with benzene gave VII followed by 137 mg of a pale yellow solid, m.p. 259–260° C after recrystallization from xylene, m/e 626, with an ether band in the IR at 1050 cm^{-1} . This compound was identified as XIII by means of x-ray crystallography* (Fig. 6) of a crystal grown by vapor diffusion of pentane into a solution of XIII in xylene.

Further elution with 10% of ethyl acetate in benzene gave 131 mg of a pale yellow solid, XIV, m.p. 223–226° C, m/e 322 and 626. In some runs this solid could not be crystallized and appeared as an oil. (It is possible that the solid reported here had already partially converted to XIII.) The IR of this solid in CCl_4 as well as of the oil contained a hydroxyl peak at 3600 cm^{-1} and a broad hydrogen-bonded hydroxyl band at 3380 cm^{-1} . The IR of the solid as a KBr pellet exhibited the broad hydrogen-bonded hydroxyl band, but no hydroxyl peak. After 3.5 days the IR spectrum of the oil, now solid, was the same as the IR spectrum of XIII. (It should be noted that the above yields were not easily reproduced from experiment to experiment probably because of the conversion of XIV to XIII during workup.)

Hydrogenation of VIII. The conditions were the same as the hydrogenation of VII above. The reaction was run with 100 mg of VIII and with either 200 mg of Pd/C or with 400 mg of Pd/C.

* XIII apparently crystallized in either D or L crystals. The absolute configuration obtained for XIII is for the particular crystal selected from the bulk sample. The two ferrocenyl units are roughly related by C_2 symmetry and are rotated about 90° perpendicular to the C_2 axis.

No colorless hydrocarbon was isolated. 78-91 mg of VIII was recovered on elution of the chromatogram with hexane, and 7-13 mg of oxygenated products were obtained on elution with ethyl acetate.

Acknowledgements

We are indebted to Drs. G.J.B. Williams and John J. Eisch for valuable discussions. We are also indebted to Dr. A. McLaughlin for the use of his NMR spectrometer and to Mr. D. Lawler for his help in obtaining the spectra. This work was supported by the Division of Chemical Sciences, U. S. Department of Energy, Washington, D. C., under contract No. EY76-C-02-0016.

References

1. F. Van Meurs F.W. Metselaar, A.J.A. Post, J.A.A.M. Van Rossum, A.M. Van Wijk and H. Van Bekkum, *J. Organometal. Chem.*, 84 (1975) C22.
2. R.B. Woodward, M. Rosenblum and M.C. Whiting, *J. Amer. Chem. Soc.*, 74 (1952) 3458.
3. E.O. Fischer, *Rec. Trav. Chim. Pays-Bas*, 75 (1956) 629.
4. D.S. Trifan and L. Nicholas, *J. Amer. Chem. Soc.*, 79 (1957) 2746.
5. A.A. Balandin, M.L. Khidekel and V.V. Patrikeev, *Zh. Obshch. Khim.*, 31 (1961) 1876.
6. E.O. Fischer, *Angew. Chem.*, 67 (1955) 475.
7. A.N. Nesmeyanov, E.G. Perevalova, R.V. Golovnya, T.V. Nikitina and N.A. Simukova, *Izv. Akad. Nauk SSSR. Otd. Khim. Nauk*, (1956) 739.
8. E.L. Muetterties and F.J. Hirsekorn, *J. Amer. Chem. Soc.*, 96 (1974) 7920.

9. A.J. Chadwell, Jr., Ph.D. Thesis, University of Tennessee, Knoxville, Tennessee, 1958; Diss. Abst., 19 (1958) 51.
10. a) See, for example, T.F. Bitterwolf and A.C. Ling, J. Organometallic Chem., 57 (1973) C15; b) unpublished results of T. E. Bitterwolf.
11. H. Alper, J. Organometal. Chem., 80 (1974) C29.
12. J.C. Gaunt and B.L. Shaw, J. Organometal. Chem., 102 (1975) 511.
13. See, for example, M. Cais, S. Dani, F.H. Herbststein and M. Kapon, J. Amer. Chem. Soc., 100 (1978) 5554.
14. M.B. Dines, Science, 188 (1975) 1210.
15. M. Hillman, B. Gordon, A.J. Weiss and A.P. Guzikowski, J. Organometal. Chem., 155 (1978) 77.
16. M. Hillman and E. Fujita, J. Organometal. Chem., 155 (1978) 87.
17. E. Fujita, unpublished results.
18. J.D. Dunitz, L.E. Orgel and A. Rich, Acta Crystallogr., 9 (1956) 373.
19. M. Hisatome and K. Yamakawa, Tetrahedron Lett., (1971) 3533.
20. M. Hillman and A.G. Nagy, J. Organometal. Chem., 184 (1980) 433.
21. K.L. Rinehart, Jr., D.E. Bublitz and D.H. Gustafson, J. Amer. Chem. Soc., 85 (1963) 970.
22. F.M. Vigo, Ph.D. Thesis, University of Illinois, Urbana, Illinois, 1969; Diss. Abst., 31 (1970-71) 598-B.
23. M. Hisatome, Y. Kawaziri, K. Yamakawa and Y. Iitaka, Tetrahedron Lett., (1979) 1777.
24. M. Hisatome, T. Sakamoto and K. Yamakawa, J. Organometal. Chem., 107 (1976) 87.
25. M. Rosenblum, A.K. Banerjee, N. Danieli, R.W. Fish and V. Schlatter, J. Amer. Chem. Soc., 85 (1963) 316.
26. T.H. Barr and W.E. Watts, Tetrahedron, 24 (1969) 3219.

27. H.M. Berman, F.C. Bernstein, H.J. Bernstein, T.F. Koetzle and G.J.B. Williams, eds., Brookhaven National Laboratory Crysnet Manual, BNL-21714 (1976).
28. P.A. Doyle and P.S. Turner, Acta Crystallogr. A24 (1968) 390.
29. D.T. Cromer and D. Liberman, J. Chem. Phys., 53 (1970) 1891.
30. R.F. Stewart, E.H. Davidson and W.T. Simpson, J. Chem. Phys., 42 (1965) 3175.
31. S.V. Markova, P.A. Bazhulin, A.F. Plate and V.I. Stanko, Optika i Spek., 8 (1960) 492.
32. D.E. Bublitz and K.L. Rinehart, Jr., Tetrahedron Lett., (1964) 827.