

PHOTOLYSIS OF TITANOCENE DICHLORIDE

ZEI-TSAN TSAI and CARL H. BRUBAKER, JR.

Department of Chemistry, Michigan State University, East Lansing, Michigan 48824 (U.S.A.)

(Received July 20th, 1978)

Summary

The photochemistry of titanocene dichloride, Cp_2TiCl_2 , I, ($\text{Cp} = \eta^5\text{-C}_5\text{H}_5$), and the $\text{CH}_3\text{C}_5\text{H}_4^-$ analog is reported. The primary process is homolytic cleavage of the Ti–Cp π bond, with formation of a CpTiCl_2 fragment and a $\dot{\text{C}}\text{p}$ radical. Both the CpTiCl_2 species and the spin adduct of the $\dot{\text{C}}\text{p}$ radical and nitrosodurene were observed by ESR spectroscopy when irradiation was carried out at -85°C . The fate of the photogenerated $\dot{\text{C}}\text{p}$ radical and the CpTiCl_2 species in different chemical environments is described.

Introduction

Although the Ti–Cp π bond in Cp_2TiCl_2 , I, is thermally inert towards substitution, photolysis of I in chlorinated hydrocarbons produced CpTiCl_3 [1]. We have also reported that the exchange of the $\dot{\text{C}}\text{p}$ ligand between molecules of I in benzene as well as alcoholysis of I in a methanol/benzene solution occurred photochemically [2]. In contrast to the photolysis of I, photocleavage of the Ti–Cp π bond in Cp_2TiMe_2 was not observed. This reaction proceeded by homolytic cleavage of the Ti–C σ bond, with the formation of what is probably titanocene and a methyl radical [3].

Photolysis of very highly purified I in dry benzene did not result in decomposition of I for very long times [2]. If less well purified I is employed, photodecomposition is observed. Traces of HCl from hydrolysis of I or introduced during its purification by extraction with CHCl_3 (saturated with HCl), may be responsible for a new photoreaction.

We have attempted to determine the primary photoinduced species of I. Ph_3CCl , nitrosodurene, and CHBr_3 were employed to react with the photolytically generated species, providing information about the behavior of I.

Dry acetone has been used as a medium for kinetics studies of the substitution reaction of I with halides [4]. The photolability of I towards acetone and alcohols has also been extended.

Results and discussion

Spectra

The band maxima and molar absorptivities are summarized in Table 1 for I and $(\text{MeCp})_2\text{TiCl}_2$. The electronic spectra of both complexes have been measured in acetonitrile, CH_3CN , and tetrahydrofuran, THF. The spectra are dominated by an intense ($\epsilon \approx 20,000 \text{ M}^{-1} \text{ cm}^{-1}$) absorption with a maximum near 250 nm. The bands of the methyl-substituted Cp ring shift to lower energies compared to those of I. Each complex also exhibits lower intensity bands near 390 and 520 nm. The band maxima and molar absorptivities depend slightly on the solvents used. Acetonitrile causes a red shift compared to THF. The shifts of the absorption bands of the methyl-substituted species to lower energies, in addition to the dependence of absorption band positions on solvents, is consistent with a report of the He^1 photoelectron spectrum of I [5]. The three excitations occur in such a way that an electron transfers from the Cp ring to the empty *d*-orbitals of the Ti metal.

ESR studies

Photolysis of a benzene solution of I in the presence of Ph_3CCl produced a $\text{Ph}_3\dot{\text{C}}$ radical, which was detectable by ESR, while the solution containing Ph_3CCl alone did not give one. This result shows that photolysis of a solution of I in the presence of Ph_3CCl undergoes radical formation [6].

Unlike an unirradiated solution, a solution of I in THF, when photolyzed for 2 min at 20°C, displayed a singlet with g 1.976. When the irradiation time was increased, a second singlet with g 1.953 gradually grew. The second peak grew faster than the first. The singlet with g 1.976 and the presence of weak satellites, attributable to hyperfine interaction with Ti isotopes, allows one to identify it (Fig. 1); it must be due to a Ti^{III} species with the unpaired electron residing largely on the metal [7]. The second singlet was not identified. After a 2.5 h irradiation, the solution turned green. Both signals last for at least 18 h, after the irradiation, in the dark, at room temperature.

In order to obtain more constructive information from a spin trapping experiment, an appropriate spin trapping agent, nitrosodurene, ArNO , ($\text{Ar} = 2,3,5,6\text{-Me}_4\text{C}_6\text{H}$) [8], was selected. A photolyzed CHCl_3 solution of I in the presence of ArNO at 20°C displayed an ESR spectrum with four equally-spaced lines (Fig. 2) with relative intensities of 1/2/2/1. The distance between two adjacent lines is 13.0 G. A reasonable assignment of this signal is 2,3,4,6-tetramethylphenyl cyclopentadienyl nitroxide, the radical resulting from Cp radical addition to

TABLE 1
ELECTRONIC SPECTRAL BAND MAXIMA FOR Cp_2TiCl_2 AND $(\text{MeCp})_2\text{TiCl}_2$

Complex	Solvent	Bands (nm) (ϵ ($\text{M}^{-1} \text{ cm}^{-1}$))
Cp_2TiCl_2	CH_3CN	522 (170), 392 (1800), 250 (19800)
	THF	515 (150), 385 (2730), 255 (17700)
$(\text{MeCp})_2\text{TiCl}_2$	CH_3CN	528 (220), 395 (1680), 255 (25300)
	THF	520 (230), 388 (1940), 258 (22500)

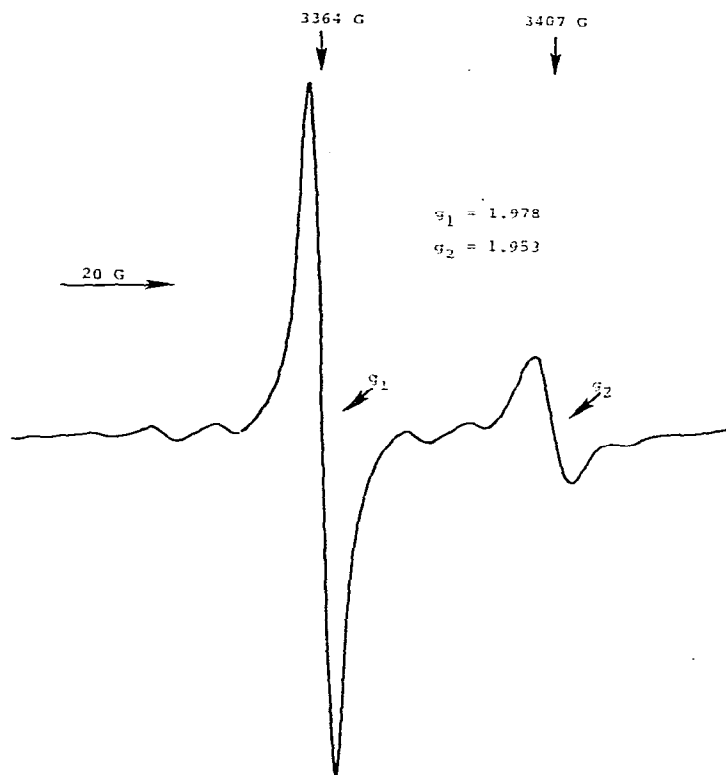
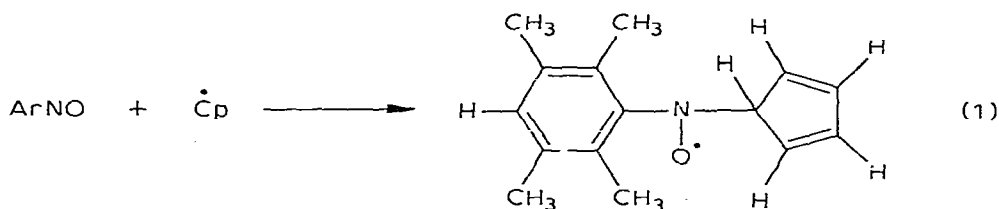

Fig. 1. ESR spectrum of the photolyzed THF solution of I at 20°C after 30 min irradiation.

nitrosodurene (reaction 1). The hyperfine splittings are $a_H = 13.0$ G and $a_N = 13.0$ G. The signal corresponding to the unpaired electron at oxygen is split



by the ^{14}N nucleus into a triplet and each of the triplets is split by the β -hydrogen on the Cp ring into a doublet and gives six lines. Since a_N equals a_H , the resulting ESR spectrum shows a quartet with relative intensities of 1/2/2/1. To confirm this assignment, the experiment was repeated with $(\text{C}_5\text{D}_5)_2\text{TiCl}_2$ and a spectrum with a triplet of triplets pattern was obtained (Fig. 3); $g = 2.005$, $a_N = 13.0$ G, and $a_D = 2.0$ G. The smaller 1/1/1 triplet is attributed to the β -deuteron ($I = 1$).

After stopping the light, the signal decayed to a much weaker six line signal. The latter could not be identified.

The spin trapping experiment with $(\text{MeCp})_2\text{TiCl}_2$ was made in order to characterize the primary photoinduced species of I further. The compound gave two

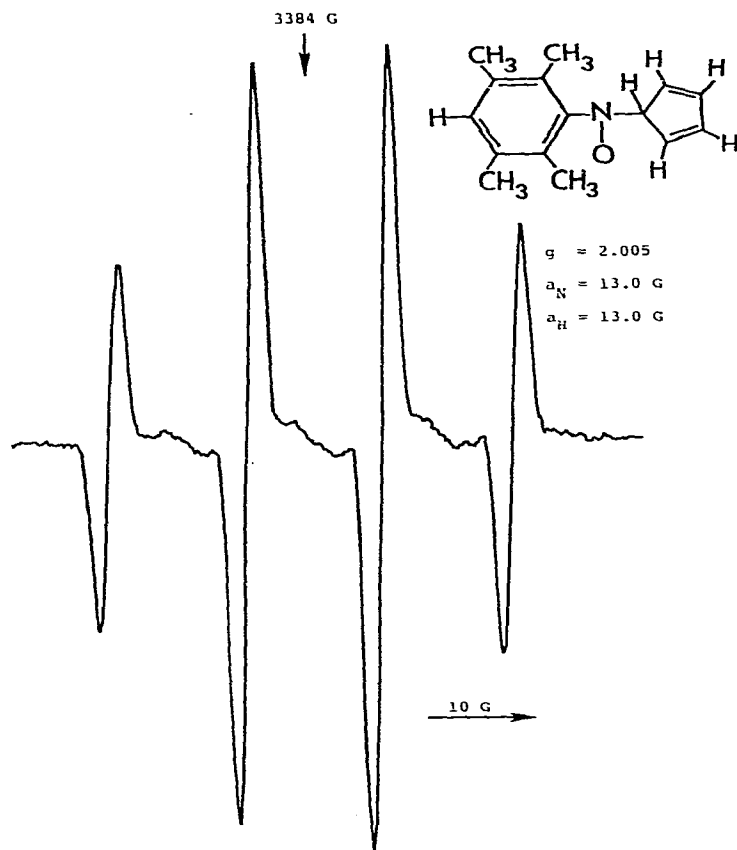

Fig. 2. ESR spectrum of the nitroxide radical obtained from a photoreaction of I with ArNO in CHCl_3 at 20°C after 1 min irradiation.

signals: a triplet and a quartet (Fig. 4), indicating that the MeCp radical can bind to nitrogen in two sites. The quartet is the same one as mentioned before, while the triplet is caused by the species that does not involve β -hydrogen.

If the photolysis of I results in the homolytic cleavage of the Ti—Cp π bonds, one expects to observe the nitroxide radical derived from a $\dot{\text{C}}\text{p}$ radical and the CpTiCl_2 species. The failure to form a detectable spin adduct of ArNO and CpTiCl_2 might be due to this adduct's readiness to undergo photolysis to produce a diamagnetic Ti(IV) species, as evidenced by a red precipitate found in the ESR tube after a 5 min irradiation. Low temperature ESR studies were attempted in order to characterize both the Cp radical and the CpTiCl_2 fragment simultaneously. The photolysis of a THF solution of I in the presence of ArNO at -85°C gave a quartet, which can be assigned to the spin adduct of the $\dot{\text{C}}\text{p}$ radical and ArNO, in addition to a singlet that may be due to the CpTiCl_2 species (Fig. 5). The other singlet with g 1.953 was not identified and also appeared in the absence of ArNO (Fig. 1).

Photolysis in the presence of bromoform

In order to gain insight into the source of chlorine for the formation of

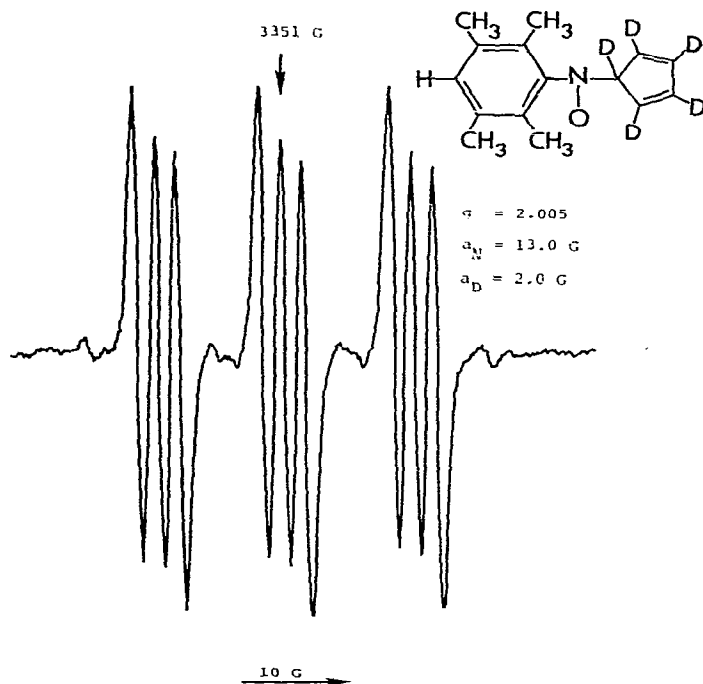

Fig. 3. ESR spectrum of the nitroxide radical obtained from a photoreaction of $(C_5D_5)_2TiCl_2$ with ArNO in THF at $20^\circ C$ after 6 min irradiation.

$CpTiCl_3$ during the photolysis of I in $CHCl_3$ [1], $CHBr_3$ was employed as a substrate. The photolysis of a benzene solution containing $8 \times 10^{-3} M$ I and $8 \times 10^{-2} M$ $CHBr_3$ yielded $CpTiCl_3$, $CpTiBr_2Cl$, and $CpTiBrCl_2$. They were isolated by sublimation and characterized by mass spectrometry. The ratio of $CpTiCl_3/CpTiBr_2Cl/CpTiBrCl_2$ was about 3/2/1 (estimated from the relative intensities of their parent peaks). This result suggests that the photogenerated $CpTiCl_2$ species may associate in its ground state or may abstract a halogen atom from either I or $CHBr_3$ and $CpTiBrCl_2$, or that $CpTiBrCl_2$ disproportionates rapidly to give $CpTiBr_2Cl$ and $CpTiCl_3$. The photopathway to $CpTiBrCl_2$ is expected to be analogous to that outlined in a previous report [1].

The corresponding unirradiated solution was stirred for 2 days in darkness and gave $Cp_2TiBrCl$, determined by mass spectrometry, instead of $CpTiCl_3$, $CpTiBr_2Cl$ and $CpTiBrCl_2$.

Photolysis in pure THF and benzene

The UV absorption spectrum of the separated THF solution from the photolyzed THF solution of I displayed two absorption peaks: 336 nm and 243 nm. The peak at 336 nm is probably due to 1,5-dihydrofulvalene, the coupling of two photogenerated $\dot{C}p$ radicals. In addition to the coupling process, the photogenerated $\dot{C}p$ radical may abstract a hydrogen atom from either solvent or I to form C_5H_6 , which has a UV absorption at about 240 nm (and may be superimposed on the 9,10-dihydrofulvalene peak) [11]. We cannot ascertain

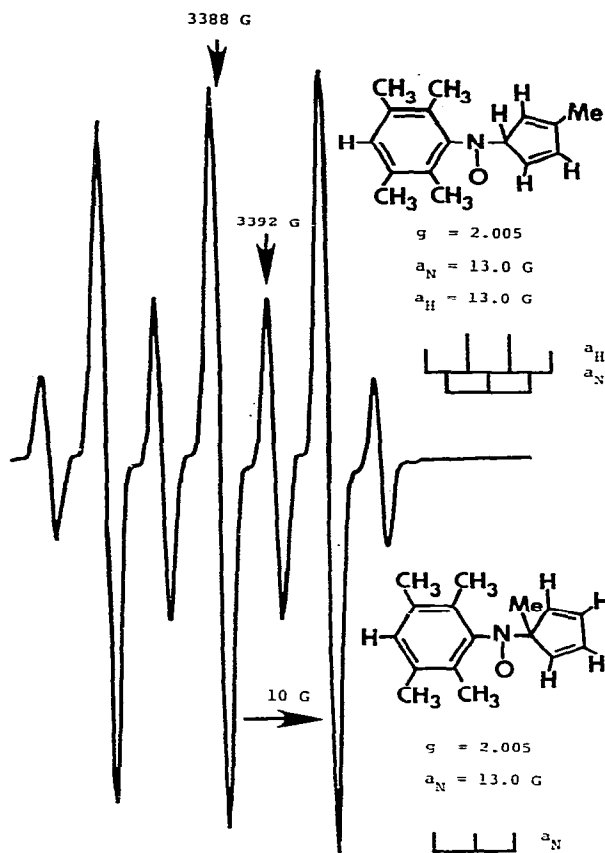

Fig. 4. ESR spectrum of the nitroxide radical obtained from photoreaction of $(\text{MeCp})_2\text{TiCl}_2$ with ArNO in chloroform at 20°C after 2 min irradiation.

that the peak at 243 nm is due entirely to 9,10-dihydrofulvalene. 1,5-Dihydrofulvalene can form from 9,10-dihydrofulvalene [11], and ought to be responsible, in part, for the 243 nm peak. The photoproduct 9,10-dihydrofulvalene amounts to about $8 \times 10^{-4} M$ (a yield of approximately 10%) and is insufficient to give a ^1H NMR spectrum.

Low temperature photolysis (-196°C) of I in benzene also produces an ESR doublet centered at $g = 2.0014$ with $a = 473$ G. It must be due to H, although a is normally greater than 500 G. The signal appears no matter whether the system is Cp_2TiCl_2 in C_6H_6 or $(\text{C}_5\text{D}_5)_2\text{TiCl}_2$ in C_6D_6 . However, the most likely source of a hydrogen radical should be the common cyclohexane impurity and it would not be deuterated during the conversion of C_6H_6 to C_6D_6 . The hexane filtrate obtained from a residue to a photolyzed THF solution of I is yellow, indicating that the residue contains CpTiCl_3 ; I is almost completely insoluble in hexane. A peak observed at 375 nm is probably due to both CpTiCl_3 and 1,5-dihydrofulvalene, while the peak at 235 nm may be due to the combined absorption of C_5H_6 and 9,10-dihydrofulvalene.

Additional information was obtained from the photolysis of a benzene solu-

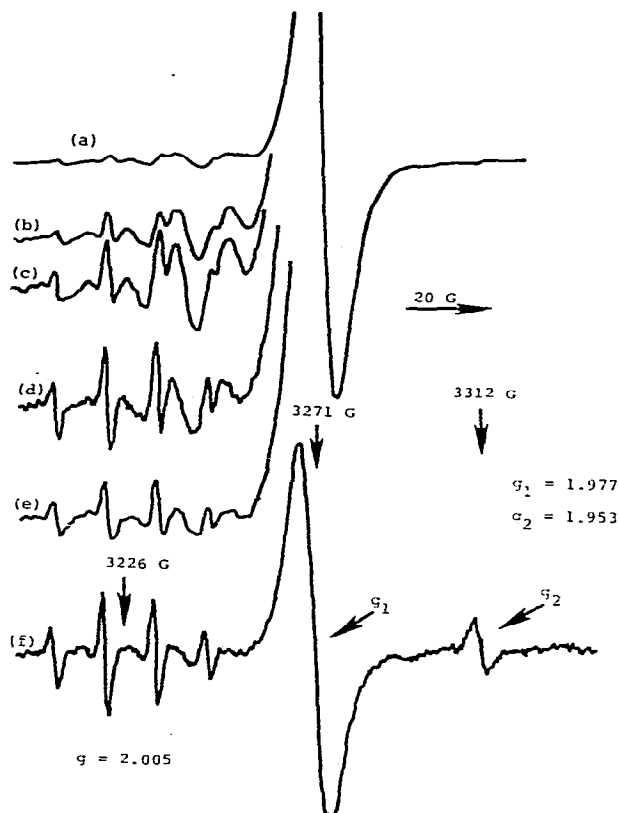

Fig. 5. ESR spectrum of a photolyzed THF solution of I in the presence of ArNO at -85°C . Irradiation time (min) (receiver gain): (a) 6 (1.6×10^2), (b) 8 (5×10^2), (c) 10 (10×10^2), (d) 12 (8×10^2), (e) 15 (8×10^2), (f) 17 (8×10^2).

tion of $(\text{MeCp})_2\text{TiCl}_2$. A peak at 329 nm may be due to the isomeric species resulting in the coupling of two photogenerated MeCp^{\cdot} radicals. The MeCp derivative is less stable toward photolysis than I, but trace impurities, such as HCl, may be responsible for the decomposition.

Photolysis in the presence of alcohols and acetone

The photolysis of I ($8 \times 10^{-3} M$ in benzene) in the presence of 1-propanol or 2-propanol ($8 \times 10^{-2} M$) produced $\text{Cp}(\text{OCH}_2\text{CH}_2\text{CH}_3)\text{TiCl}_2$ and $\text{Cp}[\text{OCH}(\text{CH}_3)_2]$.

TABLE 2
PRODUCTS OBTAINED FROM PHOTOREACTIONS OF I WITH ALCOHOLS AND ACETONE

Substrates	Irradiation time (min)	Photoproducts	M.p. ($^{\circ}\text{C}$)	Yield (%) ^a
1-Propanol	30	$\text{Cp}(\text{n-OC}_3\text{H}_7)\text{TiCl}_2$	33–34	3
2-Propanol	35	$\text{Cp}(\text{l-OC}_3\text{H}_7)\text{TiCl}_2$	105–110 ^b	30
Acetone	50	$\text{Cp}(\text{i-OC}_3\text{H}_7)\text{TiCl}_2$	105–110 ^b	22

^a Based on I. ^b Lit. [18]: 113–113.5 $^{\circ}\text{C}$. Quantum yields are not calculated because, in the presence of these reagents, some decomposition of I is observed, in addition to reaction with alcohols and acetone.

TABLE 3

MASS SPECTRAL PATTERNS OF PHOTOPRODUCTS OF I IN THE PRESENCE OF ALCOHOLS AND ACETONE

<i>m/e</i>	Ions (<i>M</i> ⁺)	Relative intensities		
		1-Propanol	2-Propanol	Acetone
242	CpTiCl ₂ (OC ₃ H ₇)	0.21	0.28	0.24
227	CpTiCl ₂ (OCHCH ₃)		1.41	1.40
213	CpTiCl ₂ (OCH ₂)	0.72		
183	CpTiCl ₂	0.76	1.15	1.16
148	CpTiCl	0.44	0.66	0.60
65	C ₅ H ₅	1.00	1.00	1.00

TiCl₂, respectively (Table 2). Both isomers can be distinguished by their mass spectra: the former has a fragment at *m/e* 213, corresponding to Cp(OCH₂)-TiCl₂⁺, while the latter has one at 227, representing Cp(OCHCH₃)-TiCl₂⁺ (Table 3).

The photoproducts were predicted in a previous report [2], in which it was suggested that the photogenerated $\dot{C}p$ radical might abstract a hydrogen atom from an alcohol molecule to give an alkoxyl radical which subsequently combines with CpTiCl₂ to produce Cp(OR)TiCl₂.

The photolysis of a benzene solution of I in the presence of acetone led to Cp[OCH(CH₃)₂]-TiCl₂, which was identified by a comparison of its mass spectral pattern with that of a known Cp[OCH(CH₃)₂]-TiCl₂ sample obtained from the light-induced reaction of I with 2-propanol, Table 3.

Quantum yields for decomposition of Cp₂TiCl₂ in the presence of all reagents tested were 0.35 ± 0.05 mol Ei⁻¹.

Conclusion

The photochemistry of I is consistent with the excitation of charge transfer, Cp ligand → Ti metal, and leads to a homolytic cleavage of the Ti-Cp π bond. While very highly purified I in benzene does not decompose photochemically, it does decompose in the presence of alcohols, acetone, or even THF. The presence of coordinating substances may permit the separation of the Cp[•] and CpTiCl₂.

Scheme 1 is a summary of the fate of the photogenerated $\dot{C}p$ radical and CpTiCl₂ species in different chemical environments, and shows the possible pathways. ROH* = 1-propanol and 2-propanol.

SCHEME 1

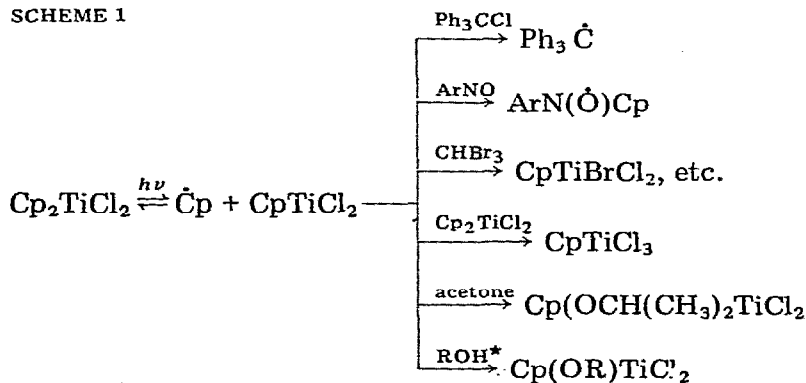

Experimental

General

Manipulations of air-sensitive complexes were carried out under an argon atmosphere, by using either Schlenk or vacuum manifold techniques.

IR spectra were obtained in Nujol by use of a Perkin—Elmer Model 457 grating spectrophotometer, mass spectra by use of a Hitachi—Perkin—Elmer Model RMU-6 mass spectrometer, ESR spectra by use of a Varian Model E-4 ESR spectrometer with a variable temperature controller, UV—visible absorption spectra by means of a Unicam Model SP-800 spectrophotometer or a Cary Model 17 spectrophotometer, and ^1H NMR by use of a Varian Model T-60 spectrometer.

Reagent or spectroscopic grade solvents were used throughout. All solvents and substrates were dried or refluxed over appropriate drying agents and distilled under argon prior to use. The drying agents were molecular sieve 4A for acetone, anhydrous CaSO_4 for alcohols, sodium benzophenone ketyl for benzene and THF, sodium metal for hexane, and calcium hydride for acetonitrile. Bromoform was used as a commercially available reagent grade chemical without further purification. Titanocene dichloride was purchased from Alfa Products and purified either by recrystallizing it twice from toluene or by Soxhlet extraction with chloroform saturated with HCl gas and argon. D_2O was obtained from the Mallinckrodt Chemical Works. Cyclopentadiene was obtained by cracking commercial dicyclopentadiene (Matheson Coleman & Bell) over BaO through a 30-cm Vigreux column. Similarly, methylcyclopentadiene was obtained by cracking the methylcyclopentadiene dimer (Aldrich Chemical Company, Inc.). C_5D_6 was prepared according to the method of Switzer and Rettig [12] beginning with C_5H_6 , KOH, and a D_2O /dioxane mixture.

Preparation of $(\text{C}_5\text{D}_5)_2\text{TiCl}_2$

Perdeuteriotitanocene dichloride was prepared from TiCl_4 (4.2 ml, 3.9 mmol) and sodium cyclopentadienide- d_5 (9 g, 9.7 mmol) in THF in argon atmosphere. The mixture was refluxed for 2 h. Then the THF was evaporated and the residue was extracted by using a Soxhlet extractor and chloroform under an HCl atmosphere, followed by cooling and filtration; yield 5 g (ca. 50% based on TiCl_4); mass spectra [m/e (relative intensity)]: 258(57), 223(17), 188(100), 153(40), 118(14), 70(21); no peaks at m/e of 248 and 65, corresponding to Cp_2TiCl_2 and C_5H_5 , respectively, were found.

Preparation of $(\text{MeCp})_2\text{TiCl}_2$

Bis(methylcyclopentadienyl)titanium dichloride was prepared by the established route [13] with some modification [14]. Sodium methylcyclopentadienide was prepared by reaction of freshly distilled methylcyclopentadiene (100 ml, about 1 mol) with sodium metal (23 g, 1 mol) in 300 ml THF under an argon atmosphere. The resulting solution (from colorless to deep violet, depending on the extent of oxidation) was added dropwise under argon to a 200 ml dry benzene solution of TiCl_4 (49.5 ml, about 0.45 mmol) which was precooled to 0°C . Once the reaction mixture had cooled, the solvent was removed under reduced pressure into a dry-ice trap. The residue was placed in a

large cellulose thimble of a Soxhlet extractor and the reaction product extracted with a mixed solvent of benzene and chloroform (1/1). Cooling of the mixed solvent solution led to red solid. This solid was collected by filtration, washed with pentane, and dried in vacuo to give 23 g of moderately pure product (19% yield based on TiCl_4). Further purification was achieved by recrystallization from toluene to give brilliant red crystalline leaflets; m.p. 219–221°C (decomp.) (lit. [14], m.p. 217–218°C, decomp.); IR spectrum (Nujol, cm^{-1}): 3100m, 500m, 1055s, 1040s, 939w, 859vs, 829m, 701w; ^1H NMR (CDCl_3): δ 2.3 (s,6), 6.25(s,8) ppm.

Preparation of nitrosodurene

Nitrosodurene was synthesized by the established procedure [15], beginning with durene, mercury acetate and ethyl nitrite; m.p. 159°C (decomp.) (lit. [15], m.p. 160°C, decomp.); IR spectrum (Nujol, cm^{-1}), $\nu(\text{N—O})$: 1510 (monomer), 1265 (*trans*, dimer).

Preparation of Ph_3CCl and $\text{Ph}_3\dot{\text{C}}$ radical

Both triphenylchloromethane and triphenylmethyl radicals were prepared by the known procedure [16], beginning with benzene and CCl_4 . The measured g value of the $\text{Ph}_3\dot{\text{C}}$ radical was 2.0027, compared to the published value of 2.0024 [17].

ESR experiments

Solutions ($8 \times 10^{-3} M$ in Ti(IV) complexes, $8 \times 10^{-2} M$ in either Ph_3CCl or ArNO) were carefully introduced into 2 mm O.D. pyrex tubes by a syringe under an argon atmosphere and were then degassed. They were then mounted in the cavity of a Varian Model E-4 spectrometer equipped with a variable temperature controller. Irradiation was carried out by use of a Hanovia model 287, 1000-W compact arc lamp in a model LH 15 1N Schoeffel Lamp Housing. The light was focused through a lens and filtered through a 4 cm water filter. DPPH (2,2-diphenyl-1-picrylhydrazyl, g 2.0037 \pm 0.0002) was used for magnetic field calibration and measurement of g values. The estimated accuracy of hyperfine coupling constants is ± 0.1 G.

Photolysis in the presence of bromoform, alcohols and acetone

The preparative photolysis apparatus is shown in Fig. 6. Argon gas was bubbled through the solution in the apparatus (set in a 20% alcohol/water bath) during irradiation and samples were withdrawn periodically by syringe. The samples were transferred into capped 1-cm quartz cells to monitor the extent of photolysis by promptly measuring the optical density at 520 nm. If the irradiated solution was exposed to air for a short time (less than 4 min), no effect on the visible absorption measurement was observed. With prolonged exposure, precipitation occurred. When the peak at 520 nm was exposed to air for a short time (less than 4 min), no effect on the visible absorption measurement was observed. With prolonged exposure, precipitation occurred. When the peak at 520 nm disappeared, the photoreaction was stopped. Then the irradiated solution was dried under vacuum at room temperature and the residue was sublimed in vacuo at 45–50°C. The photoproduct was collected from the "cold-

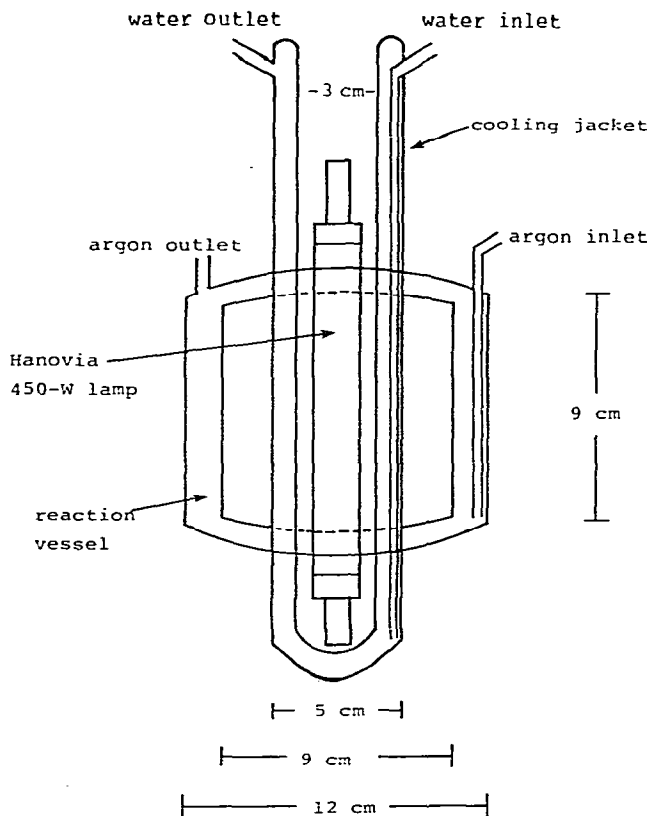

Fig. 6. The photolysis apparatus.

finger" in a dry box and identified by melting point and mass spectrometry. Thermal nonlability of these systems was confirmed by the determination of the optical density at 520 nm after a solution treated in the same way was stirred in darkness for 3 days. No significant decrease in the optical density at 520 nm was found.

Photolysis in pure THF and benzene

A 100 ml THF or benzene solution of $8 \times 10^{-3} M$ of I or $(\text{MeCp})_2\text{TiCl}_2$ was irradiated for 2.5 h at room temperature with an unfiltered 450-W Hanovia medium-pressure mercury lamp. After irradiation, the solvent was removed into a dry-ice trap and subsequently analyzed by UV spectrometry. The residue was extracted with hexane and filtered. The filtrate was analyzed by UV spectrometry.

References

- 1 R.W. Harrigan, G.S. Hammond and H.B. Gray, *J. Organometal. Chem.*, 81 (1974) 79.
- 2 (a) E. Vitz and C.H. Brubaker, Jr., *J. Organometal. Chem.*, 82 (1974) C16; (b) E. Vitz, P.J. Wagner and C.H. Brubaker, Jr., *ibid.*, 104 (1976) C33; (c) E. Vitz and C.H. Brubaker, Jr., *ibid.*, 107 (1976) 301.
- 3 (a) M.D. Rausch, W.H. Boon and H.G. Alt, *J. Organometal. Chem.*, 141 (1977) 299; (b) E. Samuel,

- P. Maillard and C. Giannotti, *ibid.*, 142 (1977) 289; (c) H. Alt and M.D. Rausch, *J. Amer. Chem. Soc.*, 96 (1974) 5936.
- 4 C.H. Langford and J.P. Aplington, *J. Organometal. Chem.*, 4 (1965) 271.
 - 5 G. Condorelli, I. Fragala and A. Centineo, *J. Organometal. Chem.*, 87 (1975) 311.
 - 6 M.S. Wrighton and D.S. Ginley, *J. Amer. Chem. Soc.*, 97 (1975) 4246.
 - 7 B.A. Goodman and J.B. Raynor, *Adv. Inorg. Radiochem.*, 13 (1970) 135.
 - 8 (a) S. Terabe, K. Kurmua and R. Konaka, *J. Chem. Soc. Perkin II*, (1973) 1252; (b) P. Schmid and K.U. Ingold, *J. Amer. Chem. Soc.*, 100 (1978) 2493.
 - 9 P.H. Kasai and D. McLeod, *J. Phys. Chem.*, 82 (1978) 619.
 - 10 M.F. Lappert and P.W. Lednor, *Adv. Organometal. Chem.*, 14 (1976) 345.
 - 11 E. Hedaya, D.W. McNeil, P. Schissel and D.J. McAdoo, *J. Amer. Chem. Soc.*, 90 (1968) 5248.
 - 12 M.E. Switzer and M.F. Rettig, *Inorg. Chem.*, 13 (1974) 1975.
 - 13 L.T. Reynolds and G. Wilkinson, *J. Inorg. Nucl. Chem.*, 9 (1959) 86.
 - 14 (a) J.L. Petersen and L.F. Dahl, *J. Amer. Chem. Soc.*, 97 (1975) 6422; (b) D.G. Sekutowski and G.D. Stucky, *Inorg. Chem.*, 14 (1975) 6422.
 - 15 L.I. Smith and F.L. Taylor, *J. Amer. Chem. Soc.*, 57 (1935) 2370; *ibid.*, 57 (1935) 2460.
 - 16 A.I. Vogel, *Practical Organic Chemistry*, Wiley, New York, 1962, p. 815.
 - 17 D.B. Chesnut and G.J. Sloan, *J. Chem. Phys.*, 33 (1960) 637.
 - 18 A.N. Nesmeyanov, O.V. Nogina and V.A. Bubovitskii, *Izv. Akad. Nauk SSSR., Ser. Khim.*, (1968) 527.