

## FERROCENE

ANNUAL SURVEY COVERING THE YEAR 1977

BERNARD W. ROCKETT and GEORGE MARR

Department of Physical Sciences, The Polytechnic  
Wolverhampton, WV1 1LY (Great Britain)

## CONTENTS

1. Reviews	53
2. Structural determinations	54
3. Stereochemistry of ferrocenes	56
4. Spectroscopic and physico-chemical studies	59
5. Reactions of ferrocene	68
6. Ferricinium salts	71
7. Ferrocenyl carbenium ions	75
8. Ferrocene chemistry	82
(i) Photochemistry	82
(ii) Derivatives containing other metals (metalloids)	83
(iii) Complexes of ferrocene-containing ligands	90
(iv) General chemistry	91
9. Biferrocenes, ferrocenophanes and annelated ferrocenes	108
10. Ferrocene-containing polymers	114
11. Applications of ferrocenes	116
(i) Ferrocene catalysts and photosensitizers	116
(ii) Ferrocene stabilizers and improvers	117
(iii) Ferrocene in analysis	118
(iv) Combustion control	119
(v) Biochemical and biological applications	120
12. References	122

## 1. REVIEWS

A supplementary volume to the Gmelin Handbook of Inorganic Chemistry on binuclear and multinuclear ferrocenes has been published [1]. The chemistry of ferrocene and related metallocenes has been discussed by Toma [2]. Abram and Watts have surveyed briefly the chemistry of ferrocene published

---

Annual Survey covering the year 1976 see J. Organometal. Chem., 148(1978)  
p.273-334

References p. 122

in 1975 [3]. Shustorovich has reviewed the molecular orbital approach to the bonding in ferrocene [4]. The synthesis of the major groups of ferrocene derivatives has been discussed by Schloegl and Falk [5]. Recent advances in the chemistry of the ferrocene derivatives of 6-aminopenicillanic acid and 7-aminocephalosporanic acid have been reviewed. The preparation, characterization and properties of these compounds were surveyed [6].

Pavlik and Klikorka have reviewed the structure, reactivity and applications of transition metal metallocene compounds [7]. Werner has surveyed the chemistry of the di- and tri-nuclear sandwich type complexes. This interesting survey underlined the use of kinetic and mechanistic studies for the development of new synthetic pathways in organometallic chemistry [8]. A general review on iron complexes by Wasson and Stoklosa included some details of ferrocene derivatives [9].

## 2. STRUCTURAL DETERMINATIONS

The crystal and molecular structure of tri-tert-butylferrocene has been determined by X-ray diffraction, solved by Patterson methods and refined by Fourier and least squares calculations. The  $\eta$ -cyclopentadienyl rings were planar and almost parallel. The rings were approximately midway between fully eclipsed and staggered with a mean twist angle of  $19^\circ$  [10]. The crystal and molecular structure of ferrocenyldiphenylsilane has been determined by X-ray analysis. The two planar cyclopentadienyl rings were tilted  $2.7^\circ$  from parallel and twisted  $13.3^\circ$  from the eclipsed configuration [11]. The structure of ferrocenylmethylpyridinium iodide has been determined by X-ray analysis. The  $\eta$ -cyclopentadienyl rings were approximately parallel and displaced by  $4.2^\circ$  from the eclipsed position [12]. The crystal and molecular structure of ferricinium tetrachlorobismuthate has been determined by X-ray analysis. The bismuth atoms were surrounded by six chloride ions in an irregular octahedron, adjacent bismuth atoms were connected by halogen bridges which gave an infinite chain of edge sharing octahedra. The ferricinium cations were stacked between the polymer chains with the cyclopentadienyl rings eclipsed and parallel to one another [13].

The crystal and molecular structure of 1,1'-(tetraphenyl-o-phenylene)ferrocene (2.1) has been determined by X-ray analysis. In the ferrocenyl group the  $\eta$ -cyclopentadienyl

rings were eclipsed and tilted by  $23.7^\circ$  [14]. The crystal and molecular structure of [15]ferrocenophane-8-one has been determined by X-ray crystallography [15]. The crystal and

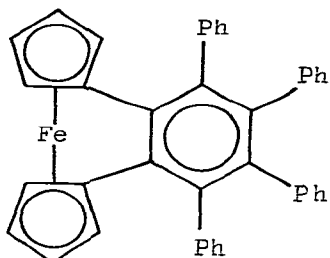

2.1

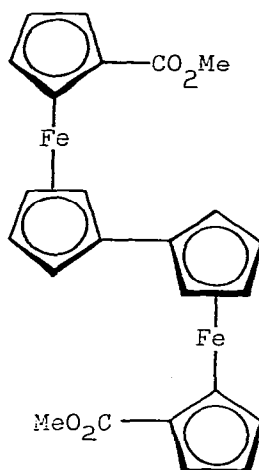

2.2

molecular structure of the bisferrocenyl derivative (2.2) has been determined by X-ray analysis. The molecule had a trans-configuration and the  $\eta$ -cyclopentadienyl rings were almost parallel and almost coplanar to the planes of the substituents [16]. Semiempirical molecular orbital cluster calculations were carried out for ferrocene, the ferricinium ion and some substituted ferrocenes. Calculated orbital energies and populations, electric field gradient tensors and electron charges at the iron atom agreed with experimentally determined values. The collapse of quadrupole splitting in the ferricinium ion with respect to ferrocene was associated with a decrease in  $\text{Fe-}3d_{x^2-y^2}$  and  $-3d_{xy}$  population and a simultaneous increase in  $\text{Fe-}3d_{xy}$  and  $-3d_{yz}$  population associated with the removal of an electron from ferrocene [17].

The atomic, bond and molecular polarizabilities of ferrocene have been calculated by quantum mechanics. The calculated values were in good agreement with those determined experimentally [18]. A method has been developed for the calculation of molecular vibrations of non-classical molecules. The method was applied to ferrocene, for which the twist vibrations were calculated [19].

## 3. STEREOCHEMISTRY OF FERROCENES

Optically active (+)-1-ferrocenyl-2-aminopropane was converted with aqueous formaldehyde to the N-methylidene derivative [(-)-3.1] which was cyclized with aqueous hydrochloric acid to the secondary amine [(+)-3.2]. This product was quaternized with methyl iodide and then subjected to Hofmann degradation to form the (dimethylamino)methylferrocene (3.3). Hydrogenation of the tertiary amine (3.3) gave 1-(dimethylamino)methyl-2-propylferrocene with 95% retention of optical purity [20]. A range of chiral ferrocenes bearing the substituents Me, CN, CO<sub>2</sub>H, CO<sub>2</sub>Me and NH<sub>2</sub> have been formed from the two

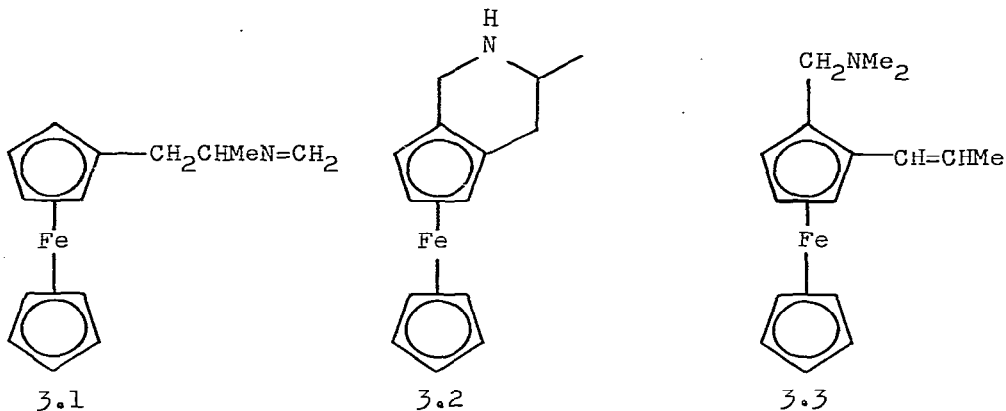

enantiomeric ferrocenes (3.4 and 3.5) of known absolute configuration. The compounds were used to test approximations of

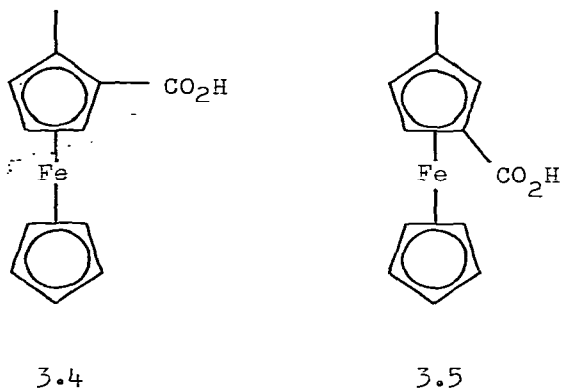

chirality functions for compounds with the basic symmetry  $C_{5v}$ . A shortened Ansatz was used in the tests and large differences were found between the calculated  $(\chi)$  and observed  $[M]_D$  values [21].

The four-component condensation of a ferrocenylmethylamine, an aldehyde, a nitrile and benzoic acid (Scheme 3.1) gave the aminomalonic acid derivative (3.6) in addition to the expected product (3.7). The reaction was carried out in methanol at low concentration and the crystal and molecular structure of an optically active phenyl analogue of (3.6) was determined by

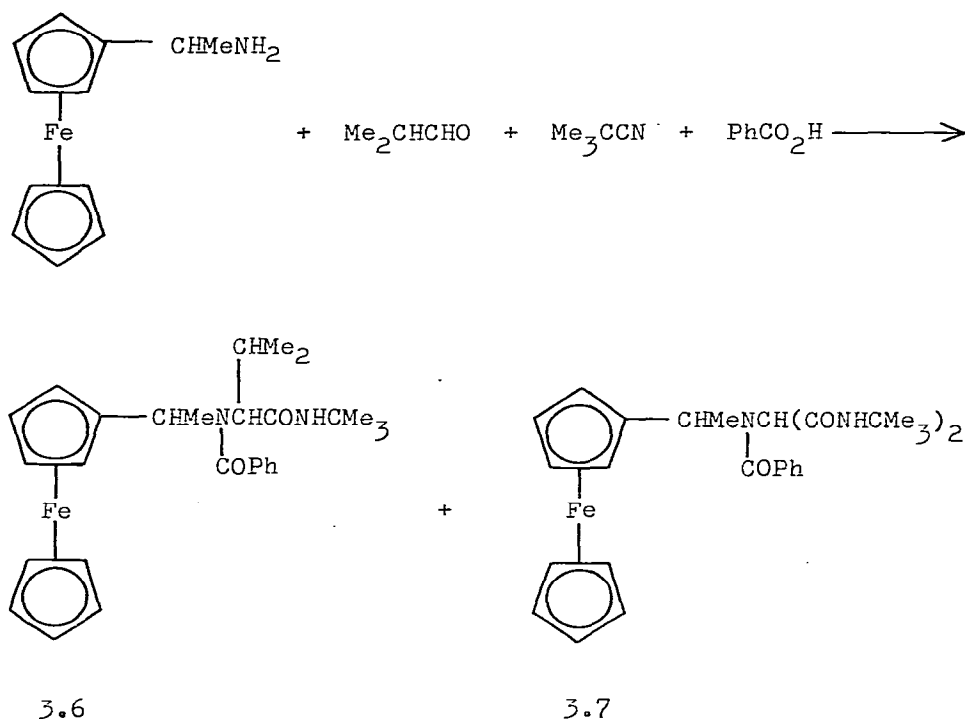

Scheme 3.1

X-ray crystallography [22]. Optically active  $\alpha$ -ferrocenyl alcohols were obtained directly from prochiral ketones by reduction with yeast. Ferrocenyltrifluoromethylketone and [3]ferrocenophan-1-one were treated with a slurry of baker's yeast and glucose to give (-)-1-ferrocenyl-2,2,2-trifluoroethanol and (-)[3]-ferrocenophan-1-ol respectively [23]. The hydrogenation of  $\alpha$ -acetamidocinnamic acid in the presence of rhodium

complexes of the type  $[(\text{diene})\text{Rh}(+)\text{PPFA}]^+\text{ClO}_4^-$ , where diene = cyclooctadiene and bicycloheptadiene and  $(+)\text{PPFA} = (S)\text{-}\alpha\text{-}[(R)\text{-}2\text{-diphenylphosphinoferrocenyl}]$ ethyl dimethylamine (3.8), proceeded in high optical yield and under mild conditions [24].

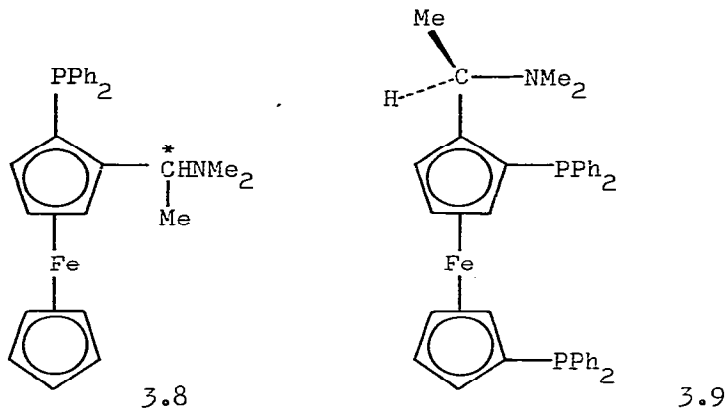

The coupling of 3-alkenyl halides with phenyl Grignard reagents in the presence of chiral nickel-phosphine catalysts has been examined. Thus 4-bromo-1-butene was coupled with phenylmagnesium bromide in the presence of the nickel chloride complex of the chiral ferrocenylphosphine (R)-(S)-(3.9) to give 3-phenyl-1-butene in which the (R)-configuration was in 34% excess over the (S)-configuration. Optically active products were obtained using similar chiral ferrocenylphosphine catalysts and a mechanistic scheme was proposed to rationalize the stereoselective character of the product [25]. The cyclopentadienyl ligand in the (+)-cyclohexene (3.10) was exchanged for a benzene ligand by heating the compound in benzene with aluminium chloride as the catalyst. The (+)-(η-benzene)iron complex obtained (3.11) showed retention of configuration and the starting material was recovered without racemization. The absolute configuration of the product (3.11) was determined by reference to the (1S)(+)-cyclohexenol (3.12) and the mechanism of the ligand exchange was discussed [26]. Orientation of substituents in the products obtained by formylation or acetylation of phenylferrocene and twenty two derivatives substituted in the phenyl group has been examined. Mixtures of 1,2-, 1,3- and 1,1'-isomers were formed and the proportions were determined by  $^1\text{H}$  NMR spectroscopy [27].

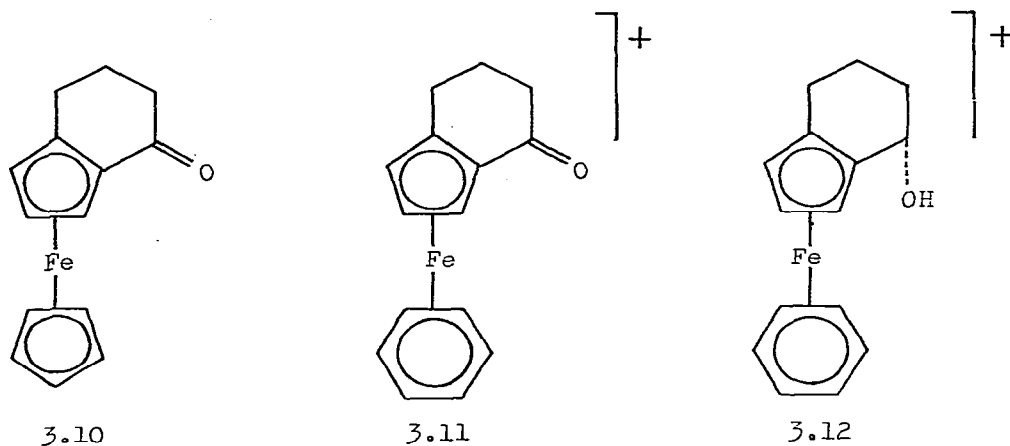

#### 4. SPECTROSCOPIC AND PHYSICO-CHEMICAL STUDIES

The reactions involved in the recoil chemistry of  $\text{Fe}^{n+}$  ions produced by neutron irradiation of ferrocene were investigated and a mechanistic scheme (4.1) was suggested for these reactions. Recombination could be either fast or slow and it led to secondary

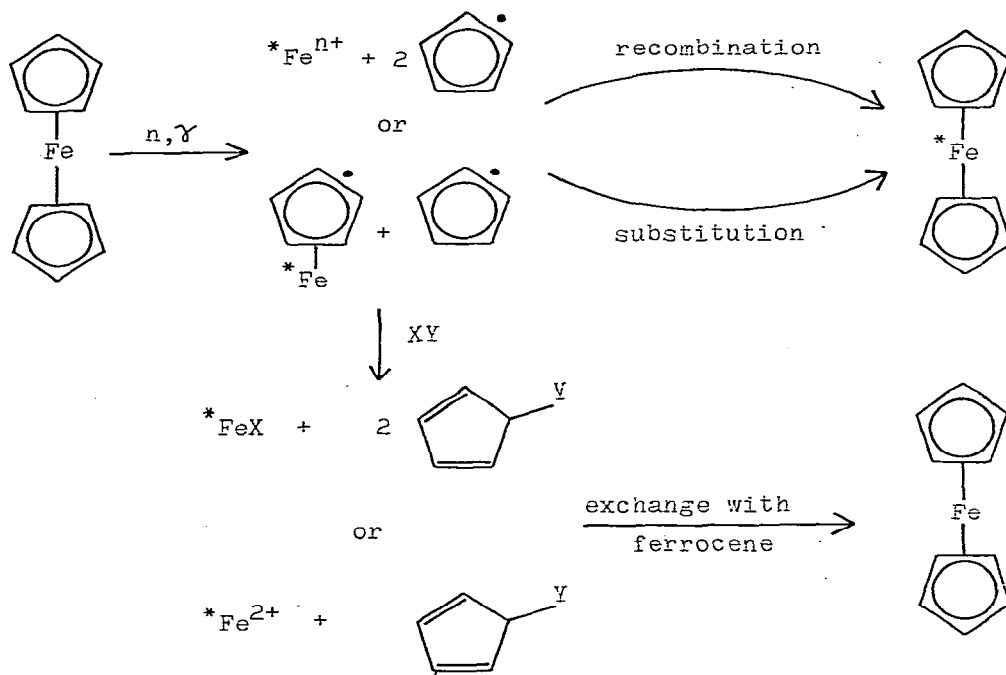

retention (retention was defined as the fraction of radioactive iron found in the form of the original compound, that is ferrocene). Recombination was influenced by ethanol, glycerol, small concentrations of Fe(II) and complexing agents such as tartaric acid and citric acid [28].

The  $^{57}\text{Fe}$  Moessbauer spectra of a series of chlorinated ferrocenes  $\text{C}_{10}\text{H}_{10-n}\text{Cl}_n\text{Fe}$  ( $n=1,2,4,6,8,10$ ) were recorded. Successive ring substitution did not significantly affect the value of the isomer shift. Anomalously large values of the quadrupole splitting were observed for octa- and deca-chloroferrocene. The origin of these anomalous values was attributed to the proximity of the chlorine atoms to the  $e_{2g}$  orbitals of the iron [29]. The vibrational properties of ferrocene were investigated by Moessbauer spectroscopy. The recoilless fractions, area ratios and isomer shifts were measured in frozen solution and in the polycrystalline form. Ferrocene underwent a phase transition at 164 K which was associated with a decrease in the recoilless fraction and an increase in the area ratio above the phase transition temperature [30]. The molecular motions of ferrocene in a viscous organic liquid, cold butyl phthalate, were investigated by Moessbauer spectroscopy. Rotational molecular diffusion was not observed in this system [31]. Moessbauer spectroscopy was used to observe the anisotropic diffusion of 1,1'-diacetylferrocene (enriched in  $^{57}\text{Fe}$ ), as the probe molecule, near the glass-supercooled smectic H liquid crystalline transition in 4-n-hexoxybenzylidene-4'-n-propylaniline [32].

Ferrocenyl-4'-methoxyaniline, ferrocenyl-4'-n-butylaniline, 1,1'-di-n-octanoylferrocene and 1,1'-ferrocene dicarboxylate were introduced into the smectic B liquid crystalline phase of 4-n-butoxybenzylidene-4'-n-octylaniline. These systems were studied by  $^{57}\text{Fe}$  Moessbauer spectroscopy [33]. Investigation of ferrocenecarbaldehyde in the temperature range 43.5-123.5 $^{\circ}$  by Moessbauer spectroscopy and microscopy has confirmed that the compound is in a plastic crystal state and not a liquid crystal state. Increased rotational mobility in the plastic crystal state was used to explain the loss of the Moessbauer effect and the birefringence at the lower transition temperature [34]. Moessbauer spectroscopy has been used to study ordering of solutes in liquid crystals. 1,1'-Diacetylferrocene containing



$^{57}\text{Fe}$  formed the solute in a supercooled monotropic smectic-B liquid crystal. The ordering influence of the liquid crystal medium on the solute was shown by the asymmetry of the quadrupole partners. However partial, rather than complete, alignment was observed [35].

Gas phase reactions of ferrocene with aromatic ligands were studied by ion cyclotron resonance spectrometry. Ion cyclotron double resonance, supported by appearance potential measurements, indicated that the reaction proceeded as follows:

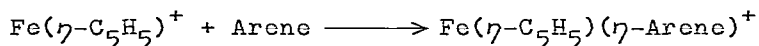

where Arene = PhH, PhMe, PhNO<sub>2</sub>, C<sub>10</sub>H<sub>8</sub>, PhOMe and C<sub>5</sub>H<sub>5</sub>N [36].

Electron resonances were observed at 0.5-2.1 eV in the scattering of monoenergetic electrons by ferrocene [37]. A detailed analysis was made of the d-d spectra of ferrocene, ruthenocene, the cobalticinium ion, biscarborane and mixed  $\eta$ -cyclopentadienyl-carborane sandwich complexes of iron (II) and cobalt (III). The ligand field parameters and nephelauxetic ratio were determined for each complex. The metal atoms were arranged in a nephelauxetic series: Ni(IV)  $\ll$  Ru(II)  $\leq$  Co(III)  $<$  Fe(II)  $<$  Ni(II)  $<$  Cr(III)  $<$  V(II) and the nephelauxetic order for the ligands was carborane  $<$   $\eta$ -cyclopentadienyl [38].

A light scattering process was observed in the ferricinium complex  $(\eta\text{-C}_5\text{H}_5)_2\text{Fe}^+(\text{FeCl}_4)^-$ , where the transitions originated in the vibrational levels of the ground electronic state and terminated on vibrational levels of the same mode of an excited electronic state. Observed and calculated data indicated that the process was dependent upon Franck-Condon overlap integrals [39].

Vacuum UV photoemissions from ferrocene, decamethylferrocene and the decamethylferrocene-tetracyanoquinodimethan complex were measured at 7.7-21.2 eV photon energies. The ionization potentials of the three compounds were 6.1, 5.1 and 5.3 eV respectively. The complex was a semiconductor with its highest occupied states 0.8 eV below the Fermi energy. The electron scattering lengths for ferrocene and decamethylferrocene were ca. 60 Å for electrons 0.5 eV above the vacuum level and decreased to ca. 2.5 Å at an energy of 16 eV [40]. Charge transfer complexes formed between ferrocene and benzoquinones have been used as optical filters in the region 3500-6000 Å. The filter materials have been used in solution, emulsion and as films [41].

The available spectral data for the  $\eta$ -cyclopentadienyl ligand was analysed and the assignments of the fundamental vibrations were discussed. The assignment of some vibrations was revised [42]. The Raman and infrared spectra of ferrocene and nickelocene were related to metal-ligand vibrations. It was found that charge-transfer effects were more important in the bonding of ferrocene than in nickelocene [43]. Several ferrocenylazo-methines (4.1; R = Ph, 3-MeO-4-HO-C<sub>6</sub>H<sub>3</sub>, 2-HOC<sub>6</sub>H<sub>4</sub>, 4-Me<sub>2</sub>NC<sub>6</sub>H<sub>4</sub>, 4-O<sub>2</sub>NC<sub>6</sub>H<sub>4</sub>, C<sub>10</sub>H<sub>9</sub>Fe, 2-furyl, 3-HO-2-C<sub>10</sub>H<sub>6</sub>) were investigated by

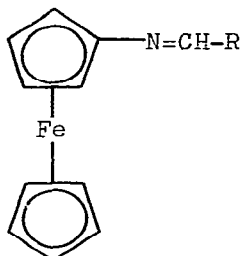

4.1

IR spectroscopy and the N=CH band assigned. Intramolecular OH.....N hydrogen bonding was detected in appropriate cases [44]. The vibrational Raman spectrum of the ferricinium ion has been investigated with respect to the electronically degenerate ground states. The  ${}^2E_{2g}$  ground state gave two spin-orbit states with an energy difference of  $600\text{ cm}^{-1}$  and an electronic excited state  $210\text{ cm}^{-1}$  above the ground state. The contribution made by asymmetric tensors to the intensity of some of the normal modes was emphasised as an important feature of the vibrational Raman selection rules in electronic degenerate states [45].

Ferrocene has been studied by magnetic circular dichroism in order to evaluate its behaviour as a potential pulmonary pathogen which could lead to granuloma formation. Two new absorption bands in the MCD spectrum were reported and the filling of the highest occupied and lowest unoccupied orbitals in ferrocene was discussed [46]. Pulse nuclear magnetic resonance measurements were made at 18 MHz to determine the activation enthalpies for the reorientation of the  $\eta$ -cyclopentadienyl rings in ferrocene and ruthenocene and the  $\eta$ -benzene rings in di( $\eta$ -benzene)-chromium. The contribution from non-bonded interactions to the

total potential for reorientation of the rings was calculated and compared with the experimental activation enthalpies. The results indicated that the potential barrier was due to a combination of the crystal packing forces and bonding forces within the molecule and that there was no contribution to the potential from the non-bonded interactions between the two rings in a single molecule. Above 135° K the crystal structure of ferrocene was thought to be disordered and a model was presented for the order-disorder transition in the solid state [47].

<sup>1</sup>H and <sup>13</sup>C NMR spectra together with INDOR experiments have been used to identify the predominant conformations of  $\alpha,\gamma$ -disubstituted [3]ferrocenophanols (4.2; R = Ph, Me). In trifluoroacetic acid the hydroxy group left the molecule from the less hindered side

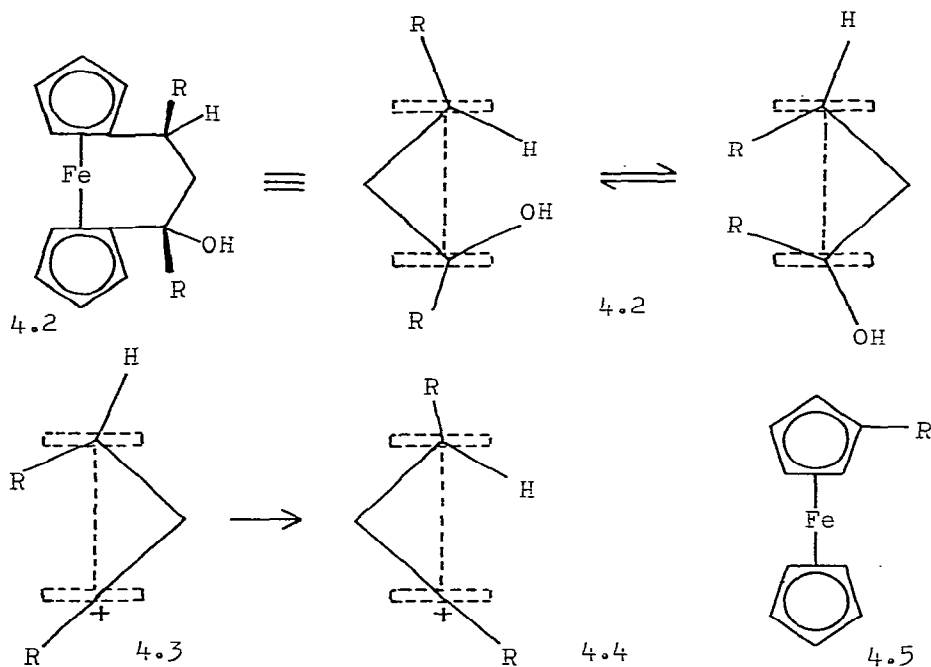

to give the corresponding carbenium ion. The cation (4.3) obtained from the syn-alcohol (4.2) was thermodynamically unstable and it slowly converted to the stable conformational isomer (4.4) [48].

The effect of alkyl substituents on the <sup>13</sup>C NMR spectra of the  $\eta$ -cyclopentadienyl groups in ferrocene and in the cobalticinium cation were investigated. The results supported the  $\pi$ -inductive mechanism for the electronic effects of the substituents [49]. High resolution <sup>13</sup>C NMR spectra of the alkyl-

ferrocenes (4.5; R = Me, Et, Me<sub>2</sub>CH, Bu, PhCH<sub>2</sub>) have been recorded and interpreted [50]. (1,1')(1,3-Cyclopentylene)ferrocenephane (4.6) was acetylated and benzoylated under Friedel-Crafts conditions. The products obtained were investigated by <sup>1</sup>H and <sup>13</sup>C NMR spectroscopy which allowed the positions of the substituents to be assigned. The NMR data was used to investigate the conformation of the cyclopentylene bridge and the results were correlated with X-ray data obtained in the solid phase. The NMR spectra of the cyclopentylene derivatives (4.7 and 4.8)

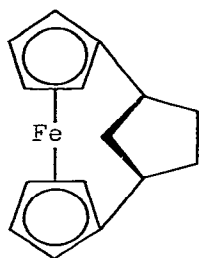

4.6

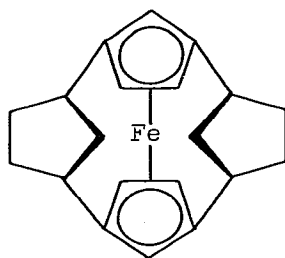

4.7

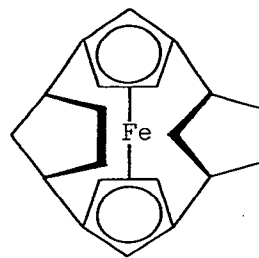

4.8

were discussed [51]. The IR, <sup>1</sup>H NMR and <sup>13</sup>C NMR spectra for a series of methylated ferrocenes, from methylferrocene to 1,2,3,4,5-pentamethylferrocene, have been recorded and interpreted. The <sup>1</sup>H NMR results confirmed that increasing methylation caused successive upfield shifts of the methyl and ring-proton resonances. <sup>13</sup>C NMR spectroscopy demonstrated that the first methyl group gave a downfield shift of the resonance of the substituted cyclopentadienyl carbon while further substitution led to upfield shifts. The methyl-carbon signals also showed upfield shifts. By contrast the unsubstituted cyclopentadienyl ring carbons showed nonmonotonic shifts of their signals to lower field as the number of methyl groups increased. At the same time the <sup>1</sup>J(<sup>13</sup>C-<sup>1</sup>H) coupling constants decreased successively because of s-p electron density redistribution on the cyclopentadienyl-iron bonds [52].

The <sup>13</sup>C NMR spectra of ferrocene and twenty four monosubstituted ferrocenes have been measured. Deuterium labelling has been used to assign the chemical shifts of the 2,5 and 3,4 carbon atoms. The electronic effects of substituents have been determined and

some general conclusions offered: the 3,4-positions of the cyclopentadienyl ring were most sensitive to resonance electron-withdrawing substituents while the 2,5-positions were most sensitive to resonance electron-donating substituents. The 3,4-positions were sensitive to substituent inductive effects but the relative shielding of C(2,5) and C(3,4) depended on the nature of the substituents and was altered even in alkylferrocenes. An analogy was observed between the shielding of C(2,5) and C(3,4) in ferrocenes and the ortho- and para-positions in benzenes with the same substituents [53]. The influence of nonresonant nuclei on NMR spin echoes in liquids and in solids was investigated. Modulations of  $^{13}\text{C}$  NMR echoes in liquid maleic anhydride and echo decays in ferrocene single crystals and in adamantane were described [54]. The  $^1\text{H}$  NMR spectra of a series of ferrocene derivatives in aqueous boron trifluoride were recorded and interpreted. The spectra of these protonated ferrocenes indicated: (i) that ferrocene compounds were protonated at the metal to produce species that were long lived on the  $^1\text{H}$  NMR time scale: (ii) that the protonated ferrocenes had a ring tilted configuration which often lead to hindered rotation of the  $\eta$ -cyclopentadienyl rings and (iii) that a strong shielding field is directed along the  $C_{2v}$  plane of the protonated molecule.  $^{19}\text{F}$  NMR spectra were recorded for m- and p-fluorophenylferrocenes and the Hammett substituent constants for the ferricinium ion and for ferrocene were calculated. Ferrocene in acid solution was oxidized by molecular oxygen and sulphur dioxide. The reaction was thought to proceed by insertion of the oxygen or sulphur dioxide into the iron-hydrogen bond [55].

The protonation of ferrocenes with  $\text{HBF}_3\text{OH}$  has been studied by  $^1\text{H}$  and  $^{19}\text{F}$  NMR spectroscopy. Mono-, 1,1'-di-, 1,1',3-tri- and 1,1',3,3'-tetra-*t*-butylferrocenes were protonated on iron to give a single species in each case while 1,3-di-*t*-butylferrocene gave two rotamers (4.9 and 4.10) which did not interconvert. Protonation of m-, and p-fluorophenylferrocene enabled the Hammett  $\sigma$  values for ferrocene and the ferrocenonium ion (4.11) to be determined. For ferrocene  $\sigma_p = -0.048$ ,  $\sigma_I = -0.014$ ,  $\sigma_R = -0.169$ ; for the ferrocenonium ion  $\sigma_p = 0.288$ ,  $\sigma_I = 0.127$ ,  $\sigma_R = 0.0$  [56].  $^1\text{H}$  NMR spectra were recorded for the 1-ferrocenyl cations prepared by ring opening of 2-ferrocenyl-2-methylcyclopropenecarboxylic acid, 2-ferrocenyltetrahydrofuran and 2-ferrocenyltetrahydropyran in trifluoroacetic acid. Treatment of

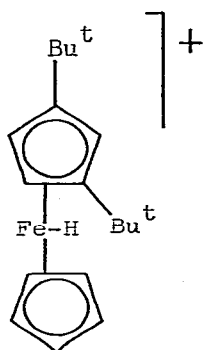

4.9

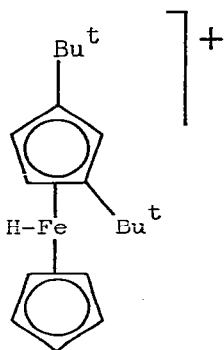

4.10

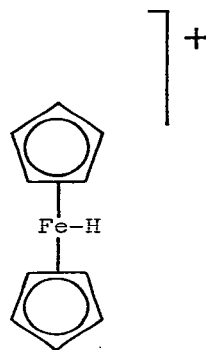

4.11

the ferrocenyl-carboxylic acid (4.12; R = Me, Et, Ph) and 2-ferrocenyl-1,3-oxathiolane with 96% sulphuric acid gave similar spectra [57]. The rate and mechanism of the electron-exchange reaction between ferrocene and the ferricinium ion were

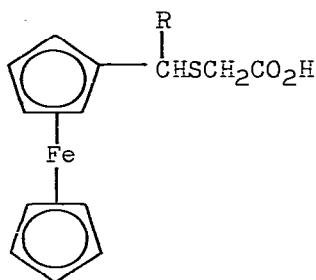

4.12

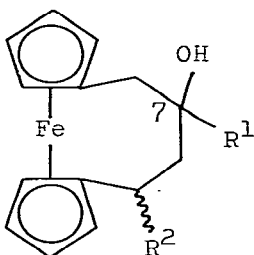

4.13

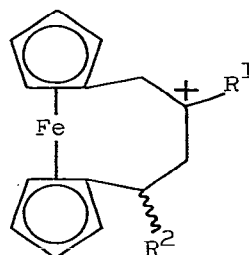

4.14

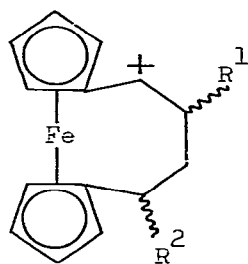

4.15

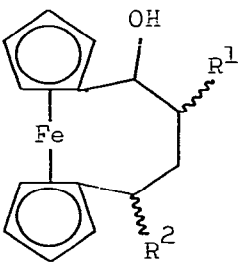

4.16

studied in non-aqueous solvents by the use of an  $^1\text{H}$  NMR line broadening technique. Alkyl substituents increased the exchange rate and the rate constants for the exchange reaction were in the range  $1 \times 10^6$  to  $6 \times 10^6 \text{ M}^{-1} \text{ sec}^{-1}$ . The application of the Marcus theory to a simple model gave theoretical values which agreed reasonably well with the experimental results [58].

The  $^1\text{H}$  NMR spectra of the secondary alcohols (4.13;  $\text{R}^1 = \text{R}^2 = \text{H}$ ;  $\text{R}^1 = \text{D}$ ,  $\text{R}^2 = \text{H}$ ;  $\text{R}^1 = \text{H}$ ,  $\text{R}^2 = \text{Me}$ ;  $\text{R}^1 = \text{H}$ ,  $\text{R}^2 = \text{Ph}$ ) in trifluoroacetic acid showed that the stable 7-carbocations (4.14) were formed. The starting alcohols were recovered by treatment of the cations with aqueous sodium carbonate. The  $^1\text{H}$  NMR spectra of the tertiary alcohols (4.13;  $\text{R}^1 = \text{Me}$ ,  $\text{R}^2 = \text{H}$ ;  $\text{R}^1 = \text{R}^2 = \text{Me}$ ;  $\text{R}^1 = \text{Me}$ ,  $\text{R}^2 = \text{Ph}$ ;  $\text{R}^1 = \text{Ph}$ ,  $\text{R}^2 = \text{H}$ ;  $\text{R}^1 = \text{Ph}$ ,  $\text{R}^2 = \text{Me}$ ) in trifluoroacetic acid indicated that the 6-carbocations (4.15) were present. When these solutions were quenched with sodium carbonate the corresponding [4]ferrocenophane-6-ols (4.16), the rearrangement products, were isolated [59]. The thermal decomposition of ferrocene, ferricinium Reineckate and potassium perchlorate, individually and mixed with poly(methyl methacrylate) was studied by differential thermal analysis. The burning rates of the mixtures containing potassium perchlorate were determined. Thermal decomposition of ferricinium Reineckate gave ferrocene, ammonia and hydrogen cyanide and the residue contained iron and chromium sulphides [60]. A polarographic study of substituted ferrocenes has shown that the half-wave potential decreased by  $\sim 47\text{mV}$  on the introduction of an alkyl group and the decrease was independent of the position of the alkyl group. Introduction of a phenyl group caused a half-wave potential increase of  $\sim 23\text{mV}$  [61].

The phase transitions of several metallocenes, including ferrocene, were determined from the specific heat curves. For ferrocene there was a phase transition at 164 K with  $\Delta H = 853 \text{ J mol}^{-1}$  and  $\Delta S = 5.31 \text{ J K}^{-1}$  [62]. In the proceedings of the 12th European Congress on Molecular Spectroscopy Freymann and co-workers presented a paper entitled "Phase Transitions in Ammonium Salts, Adamantanes, Ferrocenes and Carboranes". The bulk of the discussion in this paper dealt with the carboranes [63]. An undergraduate experiment has been described where the acetylation of ferrocene was monitored by high pressure liquid chromatography [64]. Ferrocene, substituted ferrocenes and other  $\eta$ -cyclopentadienyliron compounds were separated by high pressure liquid chromatography on a column of microparticle silica gel [65].

## 5. REACTIONS OF FERROCENE

The thiapentalene anion (5.1) was treated with iron (II) chloride to form a mixture of the isomeric bis[thiopheno(b)]-ferrocenes (5.2 and 5.3) each of which underwent reversible oxidation to the corresponding ferricinium ion [66]. The dialkyl-

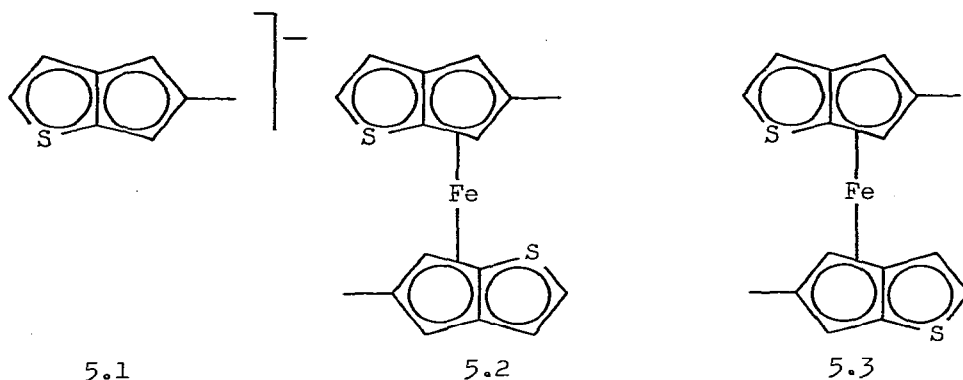

octamethylferrocenes (5.4;  $R = \text{Me}, \text{Et}, \text{Pr}^n, \text{Bu}^n, \text{Ph}$ ) were formed by treatment of the appropriate lithium cyclopentadienides with iron (II) chloride in THF [67]. UV irradiation of ferrocene with disubstituted acetylenes ( $\text{R}^1\text{C}\equiv\text{CR}^2$ ;  $\text{R}^1 = \text{H}, \text{CO}_2\text{Me}, \text{CN}$ ;  $\text{R}^2 = \text{CO}_2\text{Me}, \text{CONH}_2, \text{CN}$ ) gave a mixture of the cis- and trans-ferrocenyl-olefins (5.5, 5.6;  $\text{R}^1 = \text{H}, \text{CO}_2\text{Me}, \text{CN}$ ;  $\text{R}^2 = \text{CO}_2\text{Me}, \text{CONH}_2, \text{CN}$ ). The proportions of the two products varied with the nature of the substituent. The reaction involved an intermediate charge-transfer complex between the acetylene and ferrocene [68]. Ferrocene was

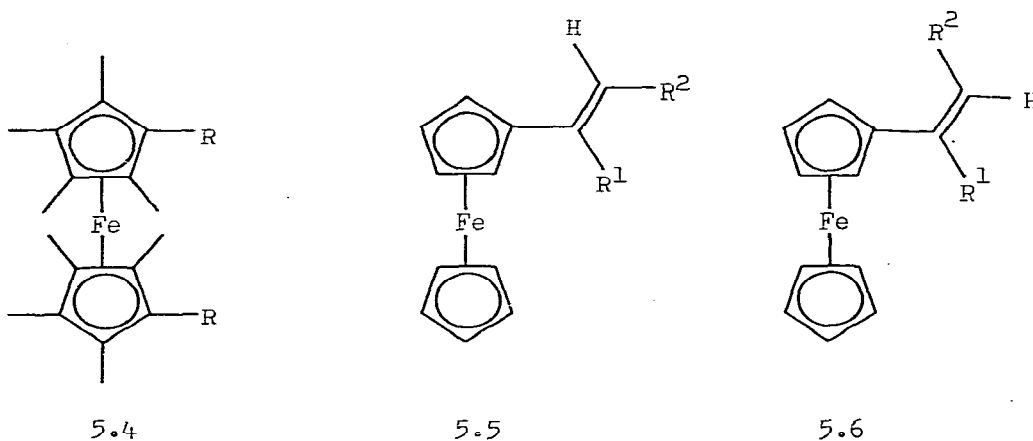



treated with mercury (II) trifluoroacetate to form the decakis-(mercuritrifluoroacetate) derivative which was converted to decaiodoferrocene (5.7) with potassium iodide and iodine and to deca(chloromercuri)ferrocene with potassium chloride [69].

The reaction of ferrocene with boron halides  $BX_3$ , where  $X = Br, I$ , in benzene gave the corresponding ferrocenyldihaloboranes and protonated ferricinium tetrahaloborates (5.8). The latter compounds (5.8;  $X = Cl, I$ ) were prepared also by the reaction of ferrocene with the boron halides in the presence of

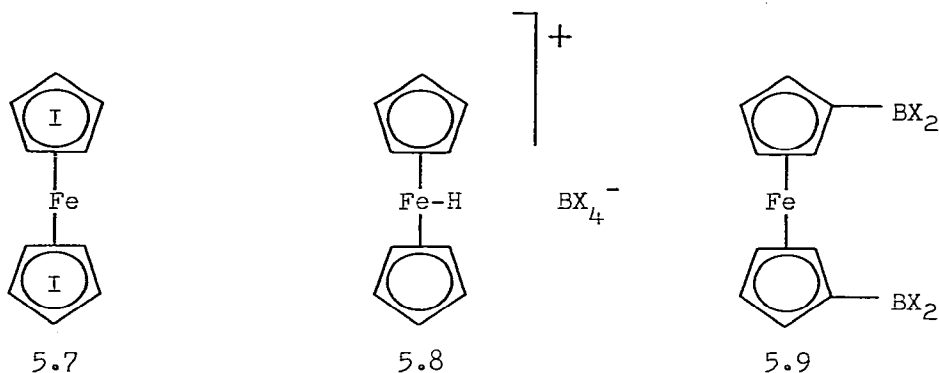

a hydrogen halide [70]. Reaction of ferrocene with boron tribromide or boron triiodide gave the corresponding 1,1'-bis-(dihaloboryl)ferrocene (5.9,  $X = Br, I$ ). Treatment of the diiodo derivative (5.9;  $X = I$ ) with arsenic(III) chloride and fluoride tetramethyltin, diethylether, methylsulphide and diethylamine gave the diborylferrocenes (5.9;  $X = F, Cl, Me, OEt, SMe, NEt_2$ ) respectively. The  $^1H$ ,  $^{11}B$  and  $^{13}C$  NMR spectra indicated increasing  $\pi$ -acceptor properties with increasing Lewis acidity of the boron groups [71].

Twenty-two anilines were diazotized and coupled with ferrocene to form arylferrocenes in low yield. The arylferrocenes were formylated and acetylated to give isomeric mixtures of the 1-acyl-2-, -3- and -1'-arylferrocenes. Condensation of the formyl derivatives with acetophenone and the acetyl derivatives with benzaldehyde gave the corresponding alkenylarylferrocenes [72]. The alkylation of ferrocene with various olefins in the presence of phosphoric acid-boron trifluoride mixtures was investigated. For example, treatment with isobutylene gave a mixture of mono-, di- and tri-*t*-butylferrocenes [73]. Friedel Crafts acylation of

ferrocene with 2-chlorobenzoyl chloride in the presence of aluminium chloride and methylene dichloride as solvent gave (2-chlorobenzoyl)ferrocene in 94% yield. Cleavage of this product with potassium t-butoxide in 1,2-dimethoxyethane led to ferrocenecarboxylic acid in 74% yield [74].

The reaction of dimethylantracene with a ferrocene-aluminium chloride-aluminium mixture gave stereospecifically [ $\eta^6$ -cis-(endo-9,10-dihydro)-9,10-dimethylantracene]( $\eta$ -cyclopentadienyl)iron cation (5.10). The ( $\eta$ -cyclopentadienyl)iron moiety was removed

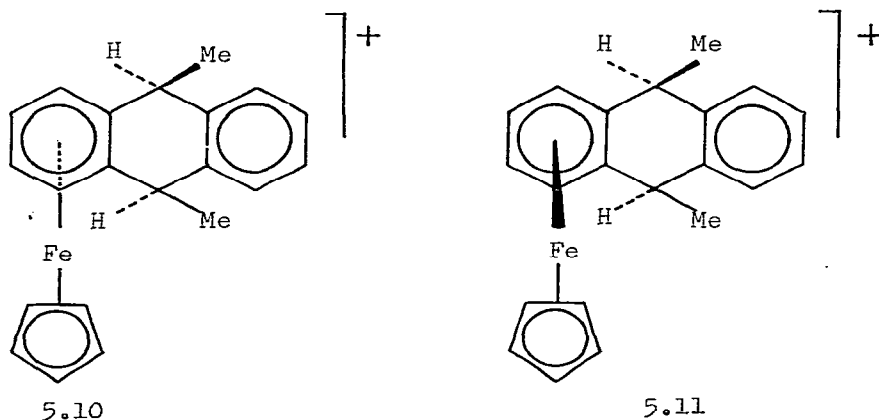

from the cation (5.10) to give cis-9,10-dihydro-9,10-dimethylantracene in good yield. When cis-9,10-dihydro-9,10-dimethylantracene was used as the ligand in the ligand exchange reaction, there was no hydrogenation and the  $\eta$ -cyclopentadienyliron group was able to complex from either side of the ring system. This gave a mixture of the cis-(endo-9,10-dihydro)cation (5.10) and the cis-(exo-9,10-dihydro)cation (5.11) [75].

The reaction of ferrocene and chloroferrocene with atomic hydrogen formed in a glow discharge plasma was investigated. Highly dispersed iron, iron carbide, carbon, hydrocarbons and an organic residue were formed in the reaction [76]. The electrochemical behaviour of 2,2,6,6-tetramethyl-4-oxopiperidinium perchlorate was studied in water-acetonitrile media. The potentials of platinum electrodes were measured in the presence of this perchlorate and ferrocene, when the ferrocene was reduced [77].

X-ray diffraction has been used to investigate the solubility of ferrocene in polyethylene. A phase diagram was constructed and was found to consist of four regions [78]. The molecular

motion of ferrocene has been studied in a viscous organic liquid, butyl phthalate. It was concluded that rotational molecular diffusion could not be observed by quadrupole relaxation. When the sample was heated from the glassy to the liquid state a fast increase in  $[X^2]$  was observed above the glass transition temperature ( $T_g$ ). This was attributed to the rapid linear increase in the number of "soft modes" for the liquid above  $T_g$  [79].

## 6. FERRICINIUM SALTS

The oxidation of ferrocene has been studied by polarography, cyclic voltammetry and controlled potential electrolysis in methanol-water mixtures and in dilute sulphuric acid. The ferricinium ion was formed reversibly and it was found to be stable in both solvents [80]. A rate constant of  $0.6 \times 10^{-2} \text{ cm}^{-1}$  was obtained, for the electrolytic oxidation of ferrocene, by cyclic voltammetry in water-ethanol solutions on a carbon-glass ceramic electrode. The oxidation was quasi-reversible and it proceeded through a fast preliminary protonation stage. Oxidation proceeded with difficulty in alkaline solution and the reversibility of the process was reduced. It was concluded that for analytical purposes in aqueous-organic systems the acid concentration should be equal to or greater than one molar [81]. Ferricinium salts were prepared by the reaction of ferrocene with  $\text{PCl}_3$ ,  $\text{AsCl}_3$ ,  $\text{AsI}_3$ ,  $\text{SbCl}_3$ ,  $\text{BiCl}_3$ ,  $\text{MePCl}_2$ ,  $\text{PhPCl}_2$ ,  $\text{MeAsCl}_2$ ,  $\text{MeAsI}_2$ ,  $\text{PhAsCl}_2$ ,  $\text{Me}_2\text{AsCl}$  and  $\text{MeSbCl}_2$ . The crystal structure of the salt  $(\eta\text{-C}_5\text{H}_5)_2\text{Fe}^+\text{BiCl}_4^-$  was determined by X-ray analysis. The salt contained bismuth atoms in an irregular octahedral environment of chlorine atoms. The bismuth atoms were linked through halogen bridges to give an infinite chain of edge-sharing octahedra [13, 82].

The monocations of acetylferrocene, methoxycarbonylferrocene and the biferrocenes (6.1;  $\text{R}^1 = \text{R}^2 = \text{H}$ ;  $\text{R}^1 = \text{COMe}$ ,  $\text{R}^2 = \text{H}$ ;  $\text{R}^1 = \text{CO}_2\text{Me}$ ,  $\text{R}^2 = \text{H}$ ;  $\text{R}^1 = \text{H}$ ,  $\text{R}^2 = \text{COMe}$ ;  $\text{R}^1 = \text{H}$ ,  $\text{R}^2 = \text{CO}_2\text{Me}$ ), (6.2;  $\text{R}^1 = \text{R}^2 = \text{COMe}$ ,  $\text{R}^1 = \text{R}^2 = \text{CO}_2\text{Me}$ ), (6.3;  $\text{R}^1 = \text{R}^2 = \text{Me}$ ;  $\text{R}^1 = \text{Me}$ ,  $\text{R}^2 = \text{CH}_2\text{OH}$ ) and (6.4) were generated electrochemically and their visible and near-infrared spectra were recorded. The monocations of the biferrocenes all exhibited visible transitions typical of ferricinium ions and the bands in the near-infrared were similar to those observed for the biferrocene monocation. The Hush model was used in predicting the effects of symmetrical and unsymmetrical substitution on the energy and intensity of the intervalence transfer bands for the substituted biferrocene cations. Band energies calculated from the electrochemical and

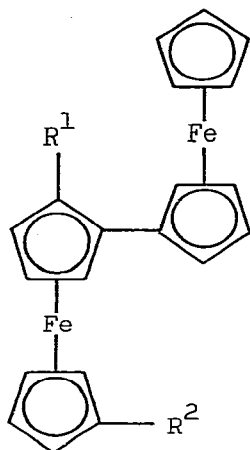

6.1

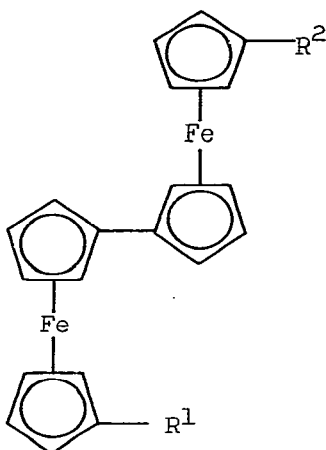

6.2

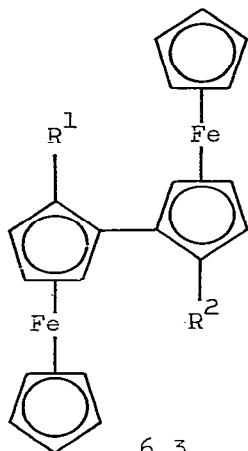

6.3

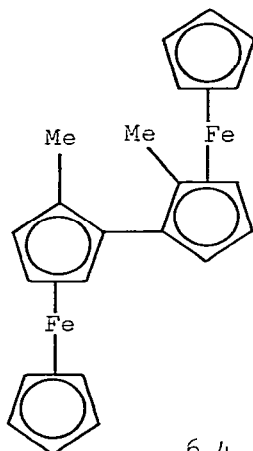

6.4

spectral data were in reasonable agreement with the observed data. [83]. Wollmann and Hendrickson have reported the preparation of meso-tetraferrocenylporphyrin  $H_2TFcP$ , (6.5) from pyrrole and formylferrocene. The presence of atropisomers was indicated by  $^1H$  NMR spectroscopy but these could not be separated by chromatography. Band shifts in the electronic absorption spectrum were explained by  $\pi$ -interaction between the ferrocenyl groups and the porphyrin. The compound was metallated with copper (II) to form meso-tetraferrocenylporphyrincopper (II),  $Cu(TFcP)$ . Oxidation of the original porphyrin and the metalloporphyrin with iodine gave the mixed valence compounds  $[H_2TFcP](I_3)_3$  and

[Cu(TFcP)] ( $I_3^-$ )<sub>3</sub> respectively. Moessbauer spectroscopy demonstrated that the three ferricinium centres in each compound were localized at ordinary temperatures while at low temperatures migration of unpaired electron density from ferricinium centres to the porphyrin ring took place [84]. Ferrocene combined with iodine in 1,2-dichloroethane to give salts containing the ferricinium cation and a polyiodide anion such as  $I_3^-$ ,  $I_4^-$  and  $I_5^-$ . The salts were dissociated in solution [85].

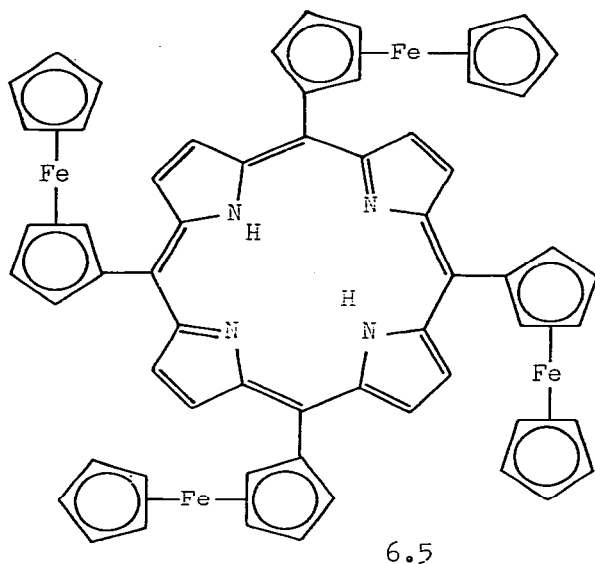

The rates of oxidation of ferrocene and ferrocenemethanols to the corresponding ferricinium ions by horseradish peroxidase in the presence of hydrogen peroxide have been determined. The oxidation proceeded with greater convenience when the enzyme was immobilized on a poly(acryloylmorpholine) gel network [86]. Gubin and co-workers found that the ferricinium cation could be substituted by alkyl radicals at a platinum electrode surface when anionic decarboxylation of carboxylic acid anions was occurring to give, after reduction, alkylferrocenes [87]. The reaction of ferricinium sulphate ( $L_2SO_4$ ) with  $(NH_4)_6Mo_7O_{24} \cdot 4H_2O$ ,  $(NH_4)_4W_5O_{17} \cdot 2.5H_2O$  and  $NH_4VO_3$  gave  $L_4Mo_8O_{26} \cdot 2H_2O$ ,  $L_6W_{12}O_{39} \cdot 3H_2O$  and  $L_2V_4O_{11}$  respectively. The complex  $L_4Mo_8O_{26} \cdot 2H_2O$  underwent dehydration at approximately  $200^\circ$  and at temperatures greater than  $400^\circ$  decomposition occurred to give ferrocene, cyclopentadiene, hydrogen and molybdenum (VI) oxide [88].

The diferrocenylalkenes (6.6 and 6.7) were reduced to the alkane (6.8) in sulphuric acid. The reduction was accompanied by oxidation of the iron atoms in the ferrocenyl groups to form a bisferricinium intermediate. A similar reaction was observed with 1,2-ferrocenylethylene and the reductions were explained by intramolecular electron transfer from iron to a carbocation centre [89]. The use of cyanuric chloride (6.9) as a linking agent for

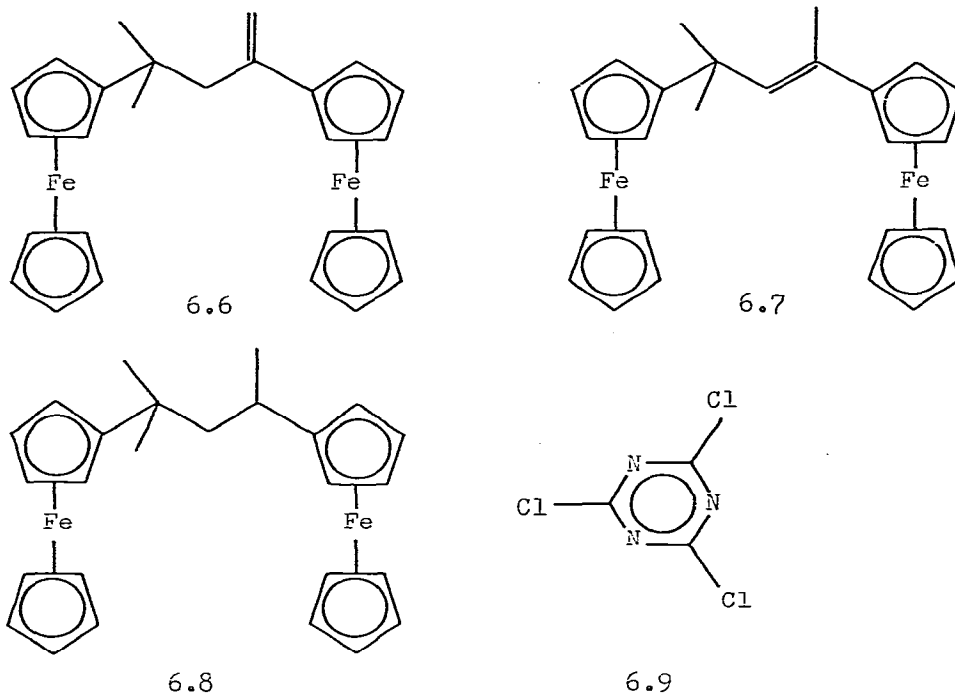

the attachment of redox groups to graphite and metal oxide electrodes was investigated. Surface hydroxyl groups were used to attach cyanuric chloride to pyrolytic graphite, tin oxide and indium oxide electrodes. Hydroxymethylferrocene was attached to the cyanuric chloride modified graphite and 1,1'-bis(hydroxymethyl)ferrocene was attached to the modified metal oxide electrodes as electroactive terminal groups. The chemically modified electrodes were then characterised by cyclic voltammetry and differential pulse polarography. The surfaces of the electrodes were examined by X-ray photoelectron spectroscopy [90].

## 7. FERROCENYL CARBENIUM IONS

The optically active carbenium ion (7.1) was generated by treatment of (+)-[3]ferrocenophan-1-ol with 100% trifluoroacetic acid [91]. The protonation of ethynylferrocenes with trifluoroacetic acid gave the corresponding ferrocenylvinyl cations which underwent rapid nucleophilic attack by the solvent to form ferrocenylcarbenium ions. Thus the ethynylferrocene (7.2) gave the vinyl cation (7.3) which in turn formed the carbenium ion (7.4). The  $^1\text{H}$  NMR spectra of vinyl cations such as (7.3) suggested the

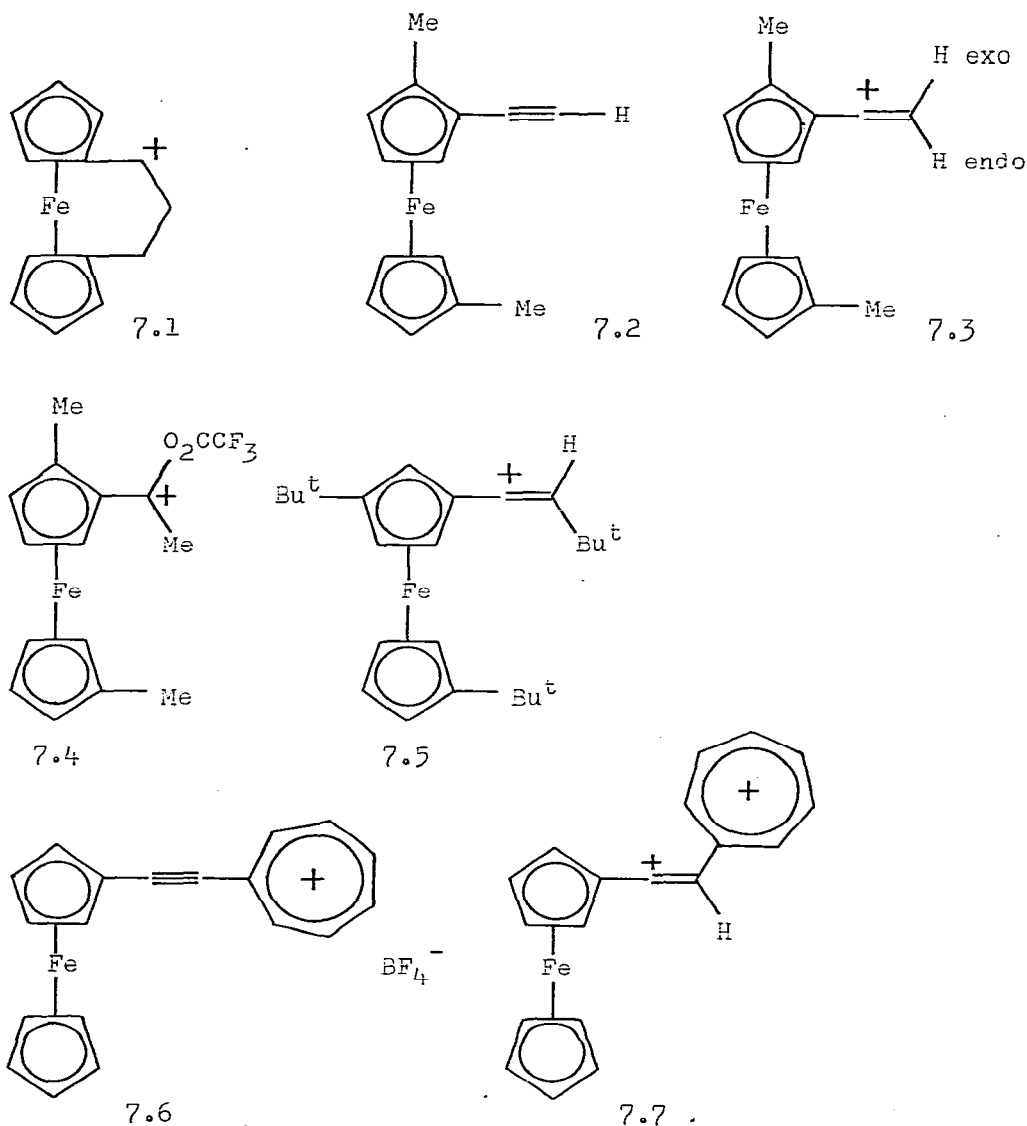

exo and endo arrangement of the terminal hydrogen atoms. Increasing alkyl substitution of the ferrocenyl group extended the lifetimes of the vinyl cations. (3,3-Dimethylbut-1-ynyl)-ferrocenes gave vinyl cations such as the t-butyl vinyl cation (7.5) which were unreactive towards the solvent. The tropylium

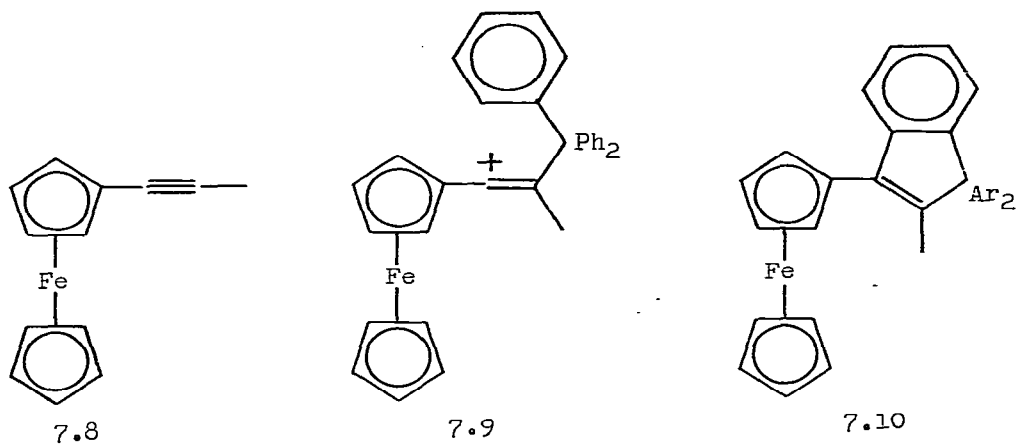

salt (7.6) gave a similarly inert vinyl dication (7.7) [92]. Treatment of 1-ferrocenylpropyne (7.8) with trityl fluoroborate

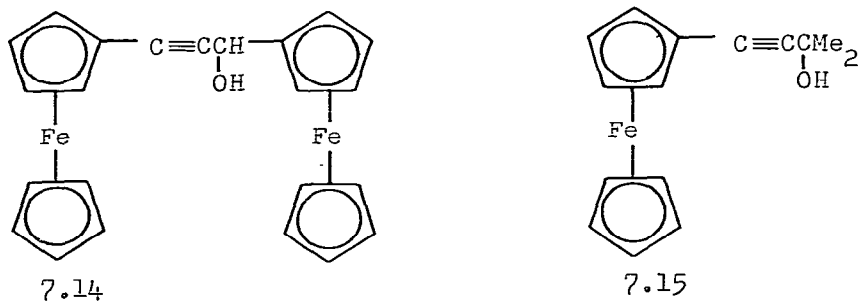
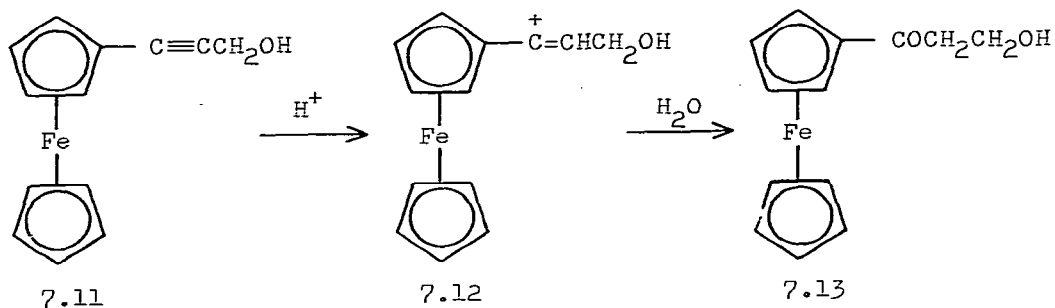



in dichloromethane gave the ferrocenylvinyl cation (7.9) which underwent intra-ionic cyclization to afford, after loss of a proton, the ferrocenylindene (7.10). Ferrocenylvinyl cations with ferrocenylmethyl, ferrocenylcarbonyl or cycloheptatrienyl groups bound to the vinylic  $\beta$ -carbon atom also underwent intra-ionic cyclization [93].

The behaviour of ferrocenylalkynols in trifluoroacetic acid has been investigated. The primary alcohol (7.11) was protonated to form the ferrocenylvinyl cation (7.12) which was isolated as the alcohol (7.13). However the secondary alcohol (7.14) and the tertiary alcohol (7.15) were dehydroxylated to form the mesomeric propynyl $\leftrightarrow$ allenyl cations (7.16a, 7.16b;  $R^1 = H$ ,  $R^2 = Fc$ ;  $R^1 = R^2 = Me$ ) respectively which underwent rapid addition by the solvent. The stable propynylium ion (7.18) was formed from the secondary alcohol (7.17) [94]. The rearrangements of ferrocenylcarbenium ions in trifluoroacetic acid have been examined. The secondary carbenium ions (7.19;  $R = Me, Ph$ ), which were formed from the corresponding secondary alcohols, rearranged by interchange of methyl or phenyl with hydrogen to give the tertiary carbenium ions (7.20;  $R = Me, Ph$ ). The methyl group migrated in preference to the phenyl group when both groups

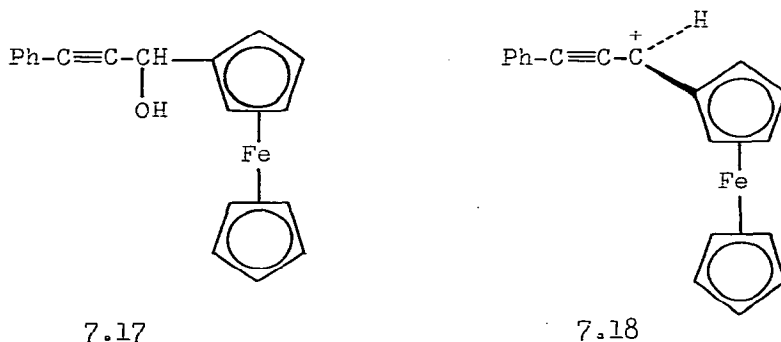
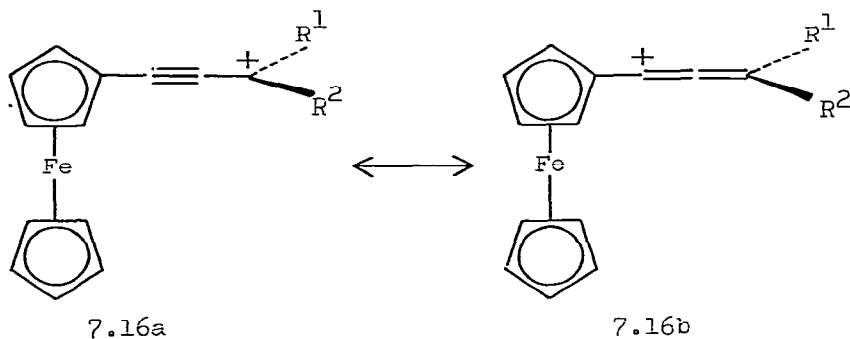

were present. The tertiary carbenium ions (7.21;  $R^1 = \text{Me}$ ,  $R^2 = \text{Ph}$ ;  $R^1 = \text{Ph}$ ,  $R^2 = \text{Me}$ ) each gave an equilibrium mixture of the rearranged carbenium ion (7.22;  $R^1 = \text{Ph}$ ,  $R^2 = \text{Me}$ ;  $R^1 = \text{Me}$ ,  $R^2 = \text{Ph}$ ) respectively and the starting material. The mechanism of rearrangement was investigated by kinetic methods and by a study of sterically constrained bridged carbenium ions. It was concluded that neighbouring group participation by ferrocenyl assisted the reaction [95].

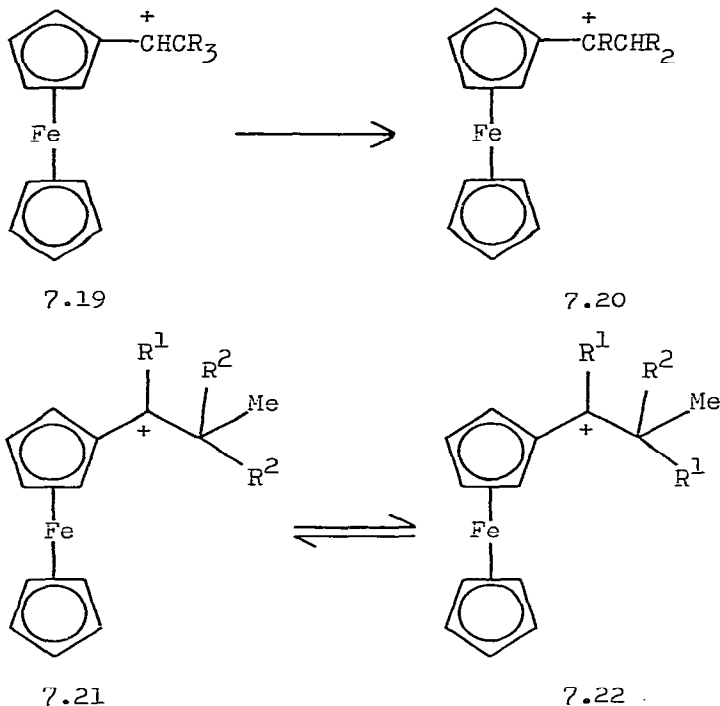

The trimethylenenorbornanols (7.23 and 7.24) each gave the appropriate stereoisomeric  $\alpha$ -ferrocenylcarbenium ion on treatment with trifluoroacetic acid. Slow rotational equilibration occurred to give a mixture in which the sterically less-crowded rotamer (7.25) was dominant [96]. The addition of water, deuterium oxide and methanol to the ferrocenylcarbenium ions (7.26;  $R = \text{CMe}_3$ ,  $\text{Ph}$ ,  $\text{CPh}_3$ ) and their subsequent deprotonation to form mixtures of the alcohols (7.27) and the vinylferrocenes (7.28) has been investigated. The carbenium ion (7.26,  $R = \text{Ph}$ ) underwent addition of water at a rate 2000x faster than the carbenium ion (7.26;  $R = \text{CMe}_3$ ) while the carbenium ion (7.26;  $R = \text{CPh}_3$ ) was inert. These differences

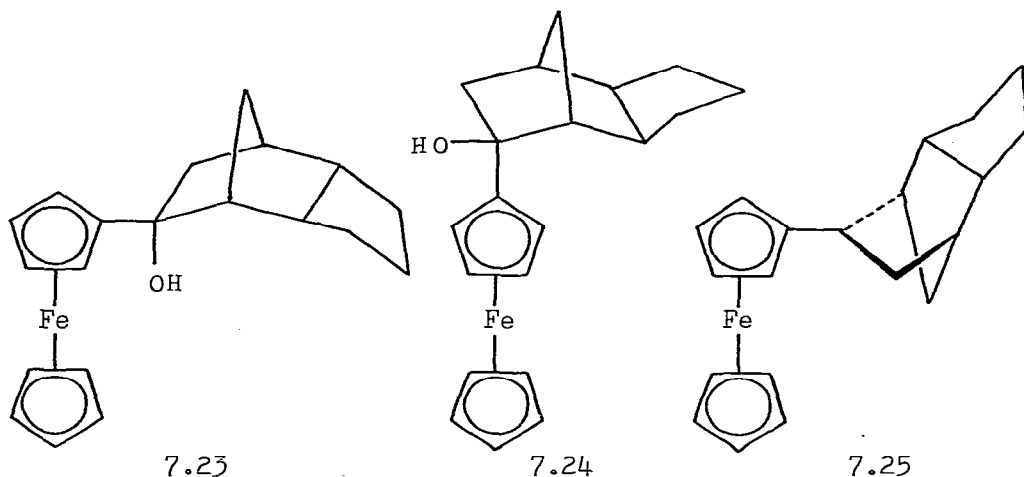

were ascribed to steric impedence to addition by the bulky  $\text{CMe}_3$  and  $\text{CPh}_3$  groups. Steric effects were also implicated in the slow elimination of the cations (7.26;  $\text{R} = \text{CMe}_3, \text{CPh}_3$ ) to the corresponding vinylferrocenes (7.28;  $\text{R} = \text{CMe}_3, \text{CPh}_3$ ) by comparison with the rapid elimination of the cation (7.26;  $\text{R} = \text{Ph}$ ) [97].

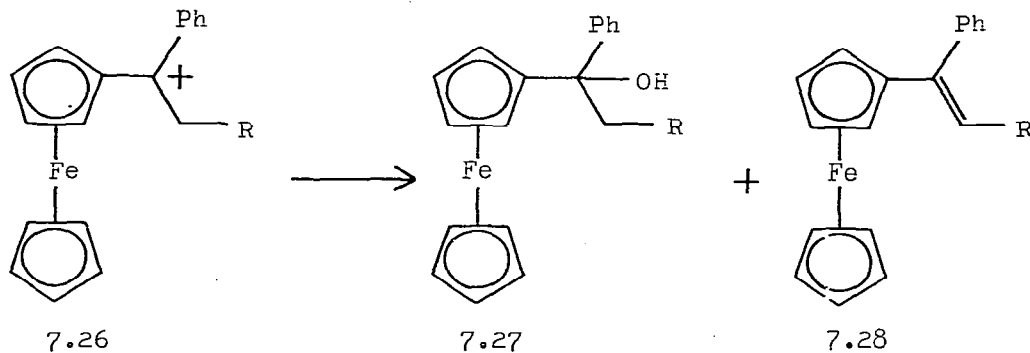

Bunton, Carrasco and Watts have investigated the spontaneous reactions with water of the ferrocenylcarbenium ions (7.29;  $\text{R}^1 = \text{H}, \text{R}^2 = \text{Ph}$ ;  $\text{R}^1 = \text{H}, \text{R}^2 = \text{p-anisyl}$ ;  $\text{R}^1 = \text{Ph}, \text{R}^2 = \text{Bu}$ ; and other combinations of these groups) which were prepared as the tetrafluoroborate salts and, in solution, as the trifluoroacetate salts by dissolving the alcohols in trifluoroacetic acid. It

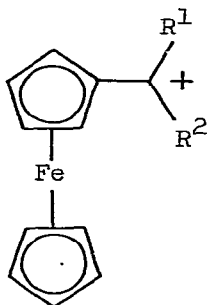

was found that the first-order rate constants,  $k_f$ , for the addition of water to the cations and the second-order rate constants,  $k_s$  for the reaction of the alcohols with  $H_3O^+$ , depended on the structure of the molecules which indicated a carbocation-like transition state. The situation was similar

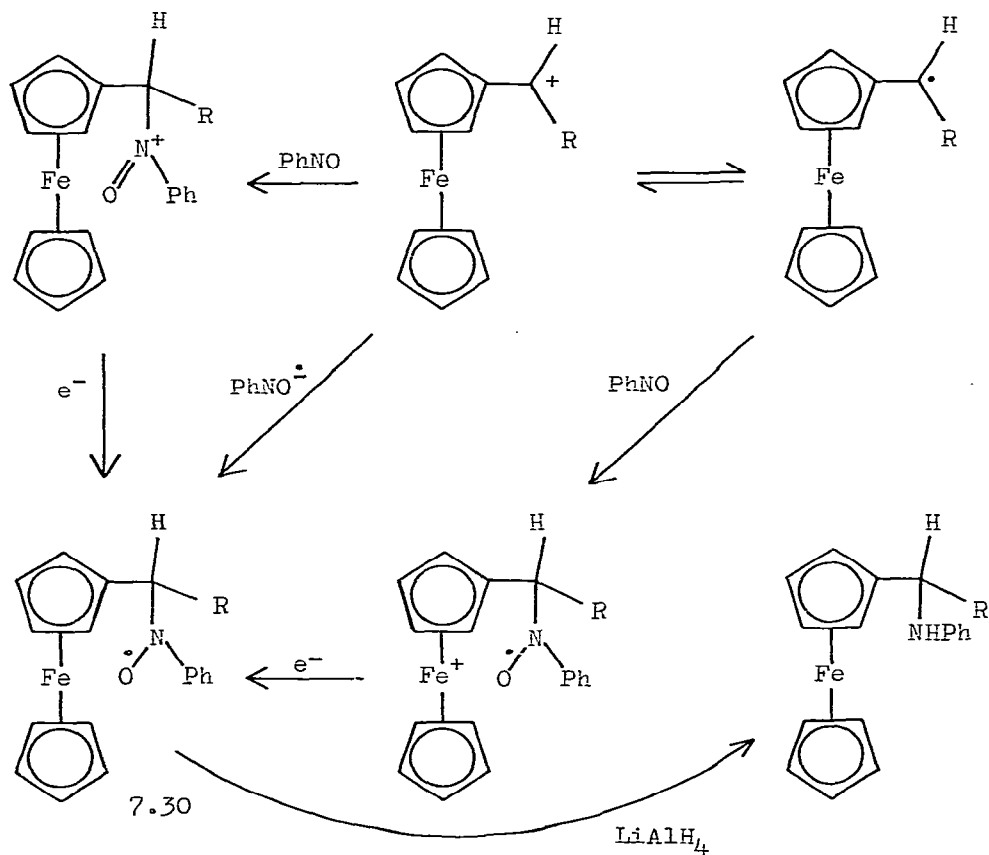

Scheme 7.1

to that observed for nucleophilic additions to triarylmethyl cations [98].  $\alpha$ -Ferrocenylcarbenium ions were treated with nitrosobenzene to give nitroxide radicals (7.30; R = Me, Ph). These nitroxide radicals were studied and characterised by ESR spectroscopy and by transformation to ferrocenyl-containing substituted anilines. Three mechanisms (Scheme 7.1) were suggested for the formation of the radicals [99].

Bicyclopropenyls were generated by cathodic dimerization of ferrocenylcyclopropenium carbocations [100]. Ferrocenylisopropylcarbinol (7.31; R = Me) and (ferrocenylmethyl)dimethylcarbinol (7.32; R = Me) each gave the  $\alpha$ -ferrocenylcarbenium ion (7.33; R = Me) on treatment with sulphuric acid at 10<sup>0</sup>. In the same way the carbenium ion (7.33; R = Ph) was formed from the carbinols (7.31, 7.32; R = Ph). The tertiary carbenium ions formed initially from the carbinols (7.32; R = Me, Ph) were converted to secondary carbocations by 1,2-hydride shifts [101]. The <sup>13</sup>C NMR spectra of several 2,5-dideuterated  $\alpha$ -ferrocenylcarbenium

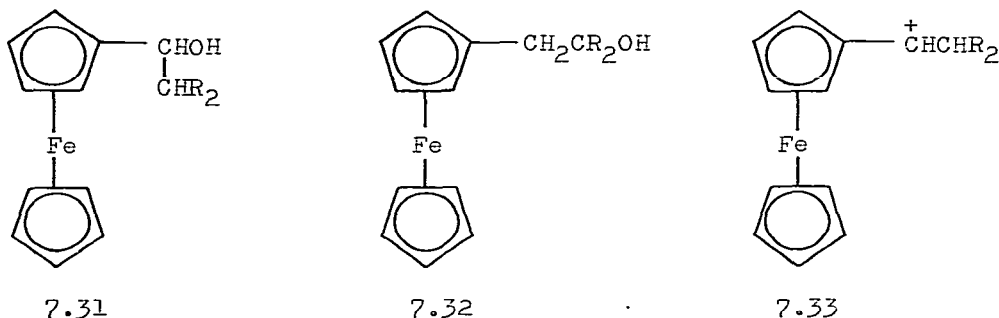

ions (7.34; R<sup>1</sup> = H, R<sup>2</sup> = H, Me, Pr<sup>i</sup>, Bu<sup>t</sup>; R<sup>1</sup> = R<sup>2</sup> = Me) have been recorded and assigned together with the spectra of the corresponding ferrocenylcarbinols. The results were interpreted in terms of an  $\alpha$ -ferrocenylcarbenium ion structure (7.35) without significant geometrical distortion from that of the neutral ferrocene. It was considered that the electron deficient centre interacted with the occupied iron d orbitals through the cyclopentadienyl group to give efficient delocalization of positive charge over the ferrocenyl nucleus [102].

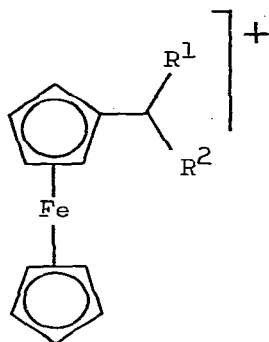

7.34

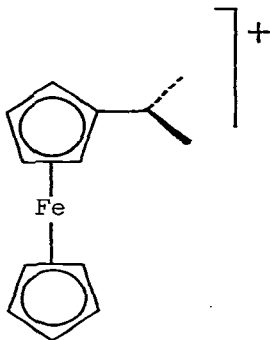

7.35

## 8. FERROCENE CHEMISTRY

### (i) Photochemistry

Monosubstituted ferrocenes underwent ethoxycarbonylation to form mixtures of the esters (8.1, 8.2) on irradiation in a carbon tetrachloride, ethanol mixture. Electron withdrawing substituents (8.1; R = Cl, Br, I, CN, COMe) inhibited the reaction while electron releasing substituents accelerated it. The reaction mechanism, which involved attack of the  $\cdot\text{CCl}_3$  radical on the cyclopentadienyl ring, was discussed [103]. Irradiation of

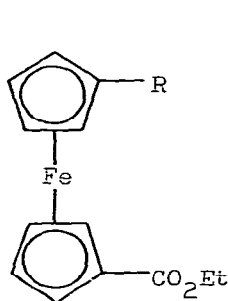

8.1

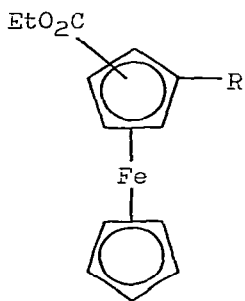

8.2

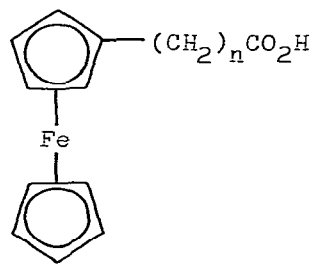

8.3

octamethylferrocene gave the corresponding ferricinium ion [104]. Singlet-singlet energy transfer to ferrocene from naphthalene, phenanthrene, triphenylene or tetracene was demonstrated by a Stern-Volmer study. Rate constants were calculated for the inhibition of fluorescence by ferrocene [105]. The photochemical reactions of acetylferrocene were studied by flash photolysis of degassed solutions in water, aqueous borax buffer, methanol and ethanol. From the results it was concluded that internal charge transfer could have led to breakdown of the molecule rather than electron photoejection or electron transfer to a solvent molecule [106].

The photolysis of acetoacetylferrocene in methanol gave acetylcyclopentadiene, cyclopentadiene and an iron (III) complex. The photolysis was carried out also in benzene, ethanol and dioxane [107]. The photolysis of benzoylferrocene has been reinvestigated by flash photolysis and, in contrast to previous work, no evidence was obtained for the formation of the benzoyl-ferricinium ion or the solvated electron when primary alcohols were used as solvents [108].

A series of ferrocene acids (8.3;  $n = 2, 3$  or  $4$ ) were dissolved as their anions in aqueous borax buffer containing nitrous oxide and irradiated with light of wavelength  $240\text{nm}$ . The ferricinium ions corresponding to the original acids were formed. The yields of the ferricinium ions were reduced by the addition of an alcohol and it was suggested that the photoexcited state was undergoing three competitive processes; first-order decay to the ground electronic state, reaction with nitrous oxide to give the ferricinium ion and quenching by the alcohol. It was concluded that the lifetime of the photoexcited state was greater than  $1\mu\text{s}$  which implied that it was probably a triplet state [109]. Ferrocene has been used as a quenching agent in an investigation of the cis-trans isomerization of 4-nitro-4'-methoxystilbene in cyclohexane [110].

(ii) Derivatives containing other metals (metalloids)

Achermann has investigated directed metallation of ferrocene-sulphonamides by *n*-butyllithium [111]. The complex formed between copper iodide and dimethylaminomethylferrocene was treated with 2-lithio-1-(dimethylaminomethyl)ferrocene to yield 2-copper-1-(dimethylaminomethyl)ferrocene (8.4) which was characterized by X-ray crystallography as a tetranuclear cluster compound. The four copper atoms were arranged in a planar square with substituted

cyclopentadienyl rings acting as bridging ligands. The nitrogen atoms did not participate in the coordination of the copper atoms [112]. The reaction of 1-lithio-2-(dimethylaminomethyl)ferrocene with silver iodide gave 1-silver-2-(dimethylaminomethyl)ferrocene. Treatment of the latter compound with iodine and copper(I)iodide-iodobenzene gave the corresponding iodo- and phenyl-ferrocenes respectively [113].

Diferrocenylmercury was heated with hexaalkyldistannanes to yield trialkylstannylderrocenes (8.5; R = Me, Et, Bu, Ph) of high isomeric purity [114]. A series of ferrocenylaminomethylphosphonates (8.6; R<sup>1</sup> = Me, Et, Pr, Me<sub>2</sub>CH, Bu, Me<sub>2</sub>CHCH<sub>2</sub>; R<sup>2</sup> = piperidino, morpholino, PhNH, *p*-MeC<sub>6</sub>H<sub>4</sub>NH, Et<sub>2</sub>N, *p*-O<sub>2</sub>NC<sub>6</sub>H<sub>4</sub>NH; R<sup>3</sup> = H, Me) was prepared by treating formylferrocene or acetyl-

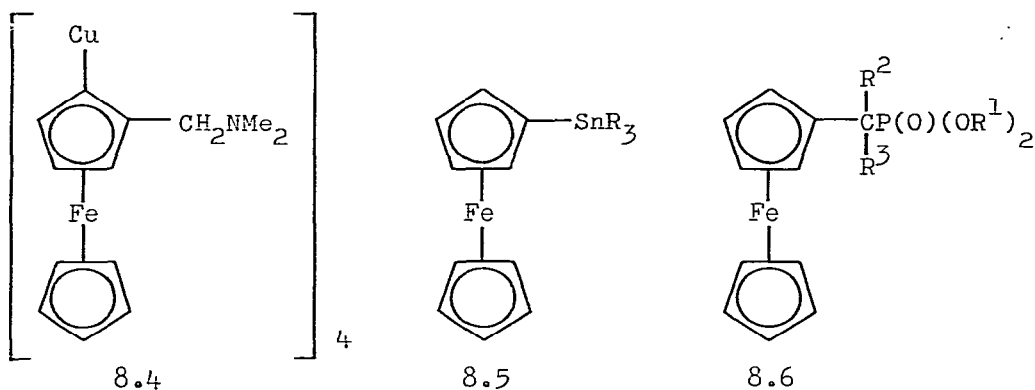

ferrocene with a phosphonate [ $\text{HP}(\text{O})(\text{OR}^1)_2$ ] and an amine ( $\text{R}^2\text{H}$ ) [115]. Isotope exchange of hydrogen for deuterium between triferrocenylphosphine and triferrocenylphosphine oxide and  $\text{CF}_3\text{CO}_2\text{D}$  was investigated. Isotope exchange in the phosphine was five to six times slower and the phosphine oxide three to four times slower than ferrocene. In triferrocenylphosphine oxide the unsubstituted  $\eta$ -cyclopentadienyl ring exchanged approximately three times as fast as the substituted ring [116].

Reaction of tetracarbonylbis( $\eta$ -cyclopentadienyl)diiron with the phospholes (8.7; R = H, Me) gave the corresponding phosphoferrocenes (8.8; R = H, Me). The crystal structure of the phosphoferrocene (8.8; R = Me) was determined by X-ray analysis. The iron atom was sandwiched between an  $\eta$ -cyclopentadienyl ring and an  $\eta$ -phospholyl group with the rings eclipsed. The  $\eta$ -phospholyl ligand was not strictly planar, with the phosphorus atom slightly



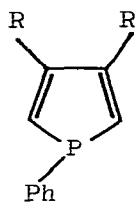

8.7

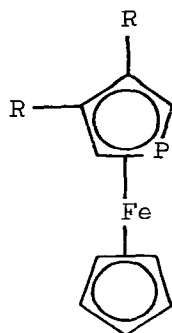

8.8

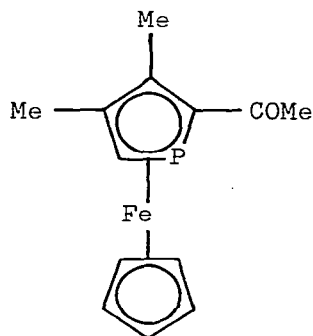

8.9

displaced from the plane of the four carbon atoms. The phosphoferrocene (8.8; R = Me) was acetylated selectively on the  $\eta$ -phospholyl ligand to give the acetyl-ferrocene (8.9) [117]. Treatment of dicarbonyl( $\eta$ -cyclopentadienyl)iron dimer with 1-phenylphosphole in boiling xylene gave a mixture of phosphoferrocene (8.10), 2-phenylphosphoferrocene (8.11; R = H) and 3-phenylphosphoferrocene (8.12). When 1-phenyl-3,4-dimethylphosphole was used as the reagent then the trisubstituted phosphoferrocene (8.11; R = Me) and 3,4-dimethylphosphoferrocene were obtained. Acetylation of phosphoferrocene took place exclusively in the phospholyl ring to give the 2-acetyl and 3-acetyl derivatives in the ratio 85 : 15 [118].

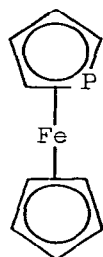

8.10

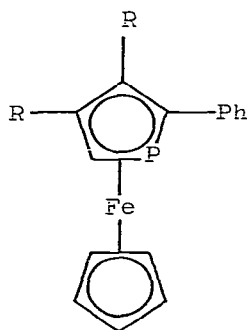

8.11

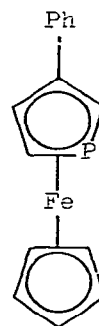

8.12

Di( $\eta$ -cyclopentadienyl)diferrocenyltitanium (8.13;  $M = \text{Ti}$ ) was obtained by stirring bis( $\eta$ -cyclopentadienyl)titanium dichloride with ferrocenyllithium in THF. The zirconium and hafnium analogues (8.13;  $M = \text{Zr, Hf}$ ) were obtained in the same way. All three were air sensitive and were attacked by hydrogen chloride to form the di( $\eta$ -cyclopentadienyl)metal dichloride and ferrocene [119]. Crawford and Kaesz have investigated the metallation of substituted ferrocenes with pentacarbonyl(methyl)-manganese and -rhenium. Acetylferrocene gave the cyclometallated products (8.14;  $M = \text{Mn, Re}$ ;  $L = \text{CO}$ ) of which the manganese compound was labile to reaction with carbon monoxide and triphenylphosphine forming the derivatives (8.15 and 8.14;  $M = \text{Mn}$ ;  $L = \text{PPh}_3$ ) respectively. Benzoylferrocene was metallated exclusively in the benzene ring to give the cyclometallation product (8.16) while treatment of (dimethylamino)methylferrocene with pentacarbonyl(methyl)manganese gave a cyclometallation product which involved an N-methyl group (8.17) [120]. X-ray diffraction has been used to determine the crystal and molecular

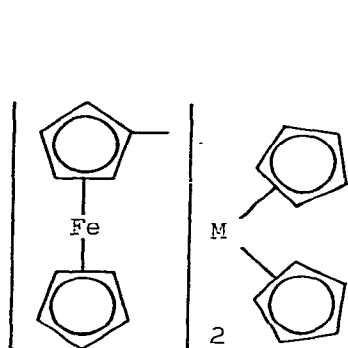

8.13

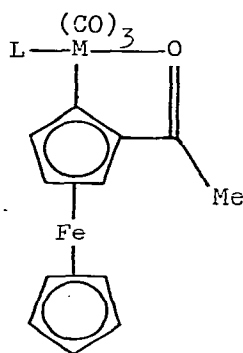

8.14

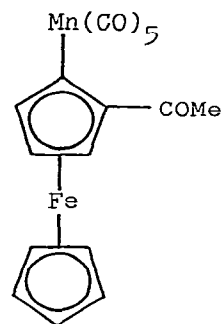

8.15

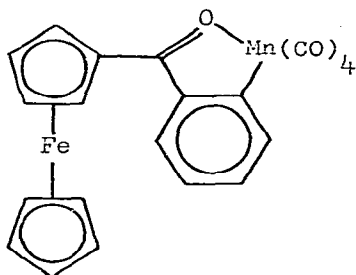

8.16

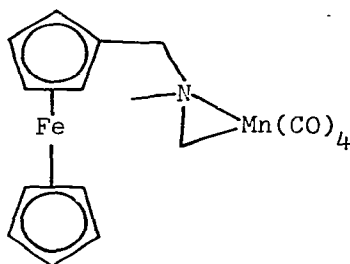

8.17

structure of this compound, N-ferrocenylmethyl-N-methylaminomethyl-(tetracarbonyl)manganese (8.17). It contained a novel Mn-C-N metallocycle with a C-N bond length of 1.42 Å [121].

Reaction of phenylethylnylferrocene with the cobalt complexes (8.18;  $R^1 = R^2 = \text{Ph}$ ;  $R^1 = \text{Ph}, R^2 = \text{CO}_2\text{Me}$ ;  $R^1 = R^2 = \text{CO}_2\text{Me}$ ) gave the corresponding  $\eta$ -cyclobutadiene complexes (8.19) together with the cobaltacyclopentadiene type products (8.20). Treatment of phenylethylnylferrocene with  $\eta$ -cyclopentadienylbis-(triphenylphosphine)cobalt gave the isomeric diferrocenylcyclobutadiene complexes (8.21 and 8.22). Reaction of 1,1'-bis(phenylethylnyl)ferrocene with the cobalt complexes (8.18;  $R^1 = R^2 = \text{Ph}$ ;

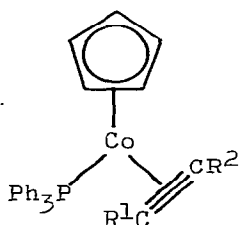

8.18

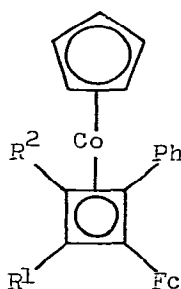

8.19

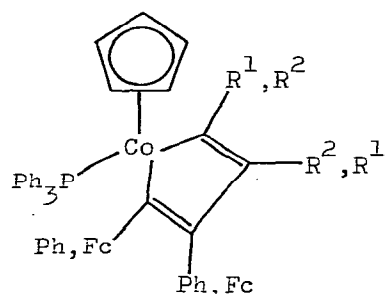

8.20

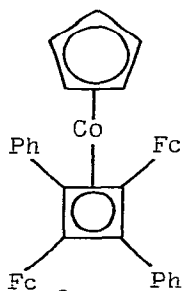

8.21

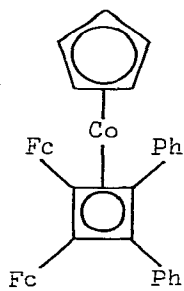

8.22

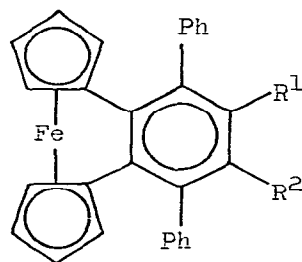

8.23

$R^1 = \text{Ph}, R^2 = \text{CO}_2\text{Me}$ ;  $R^1 = R^2 = \text{CO}_2\text{Me}$ ) gave the corresponding [2]ferrocenophanes (8.23) [122]. Acetylferrocene N,N-dimethylhydrazone was treated with lithium tetrachloropalladate (II) in the presence of sodium acetate to give the cyclic ring metallated product (8.24). This complex (8.24) underwent reaction with the ligands (L) (L = dimethylsulphoxide, 4-methylpyridine, triphenylphosphine and 1-phenethylamine) to give the corresponding monomeric complexes (8.25) [123].

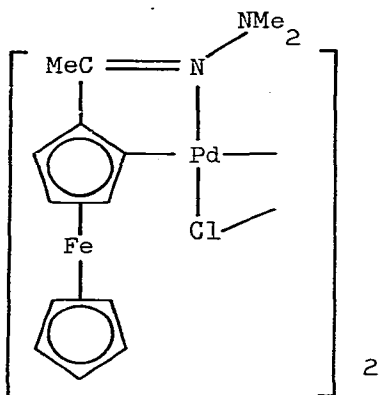

8.24

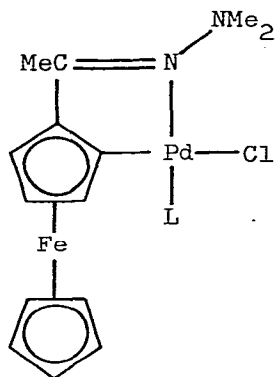

8.25

The palladation of (+)-1-(dimethylaminoethyl)ferrocene (8.26) with sodium tetrachloropalladate (II) gave a 85 : 15 mixture of the two diastereoisomers (8.27 and 8.28). Metallation of (+)-1-(dimethylaminoethyl)ferrocene with *n*-butyllithium proceeded with stereoselectivity 96 : 4 and treatment with mercury (II) chloride gave the mercuri-ferrocene (8.29). This increase in stereoselectivity on lithiation was attributed to the difference in mechanism of the two metallation reactions [124]. Reaction

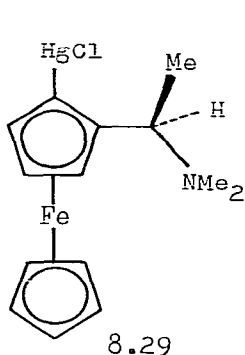
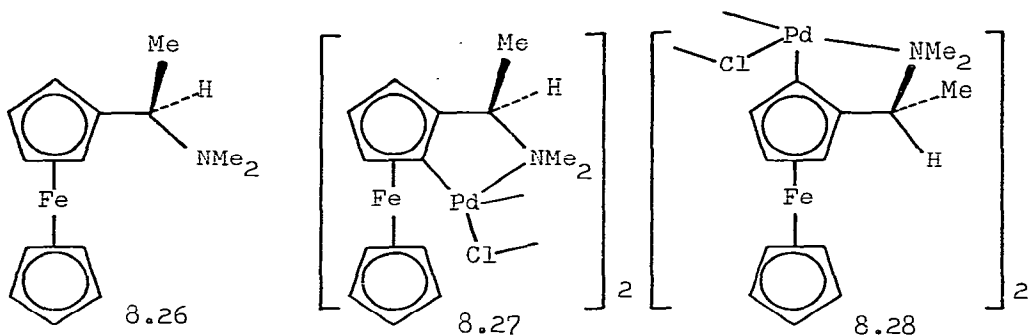

8.29

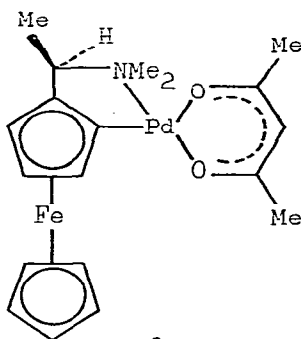

8.30

of (+)-1-(dimethylaminomethyl)ferrocene with sodium tetrachloropalladate gave a mixture of internally metallated compounds (8.27 and 8.28). Treatment of the latter compound (8.28) with sodium acetylacetonate gave the palladium complex (8.30) [125].

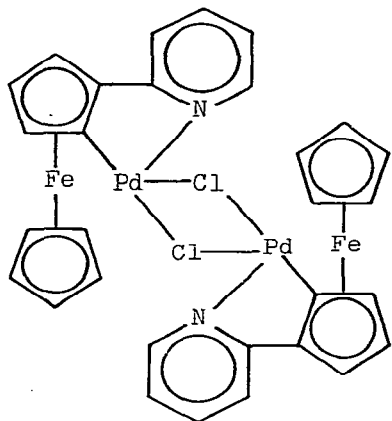

8.31

Treatment of lithium tetrachloropalladate with pyridylferrocene in the presence of sodium acetate gave the ortho-metallated binuclear complex (8.31). Some reactions of the complex were described [126]. Ferrocene was treated with the salt  $[(\text{Ph}_3\text{PAu})_3\text{O}]^+ \text{BF}_4^-$  in chloroform and in the presence of fluoroboric acid to form the cationic gold complex (8.32) which was converted to the neutral gold triphenyl phosphine compound (8.33) with chloride ion or triphenylphosphine [127]. The mercurihalide

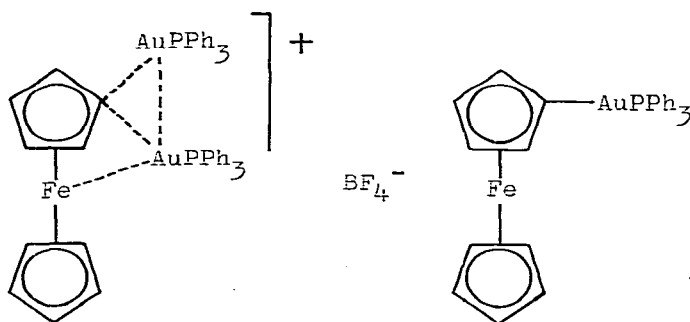

8.32

8.33

complexes (8.34; X = Cl, Br and 8.35) were studied by IR and UV spectroscopy. Charge-transfer bands were observed at 360nm and ascribed to  $(\eta\text{-C}_5\text{H}_5)\text{Fe} \rightarrow \text{HgX}_2$  interactions. Irradiation of the complexes at wavelengths corresponding to the charge-transfer bands caused oxidation of the ferrocene to ferricinium and reduction of the mercury (II) to mercury (I) as the mercurous ion [128].

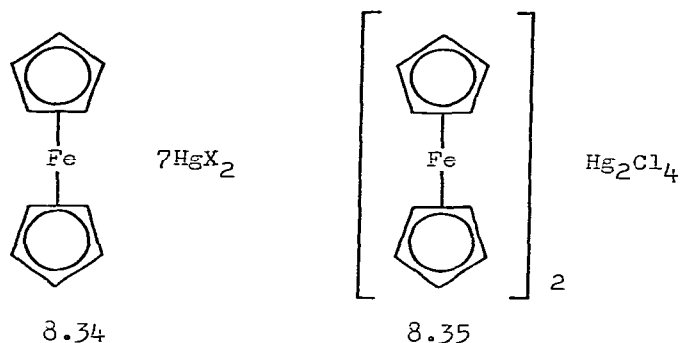

(iii) Complexes of ferrocene-containing ligands

Several 1,1'-bis(dimethylarsino)ferrocene (Fdma) complexes of rhodium (I) were prepared and their reactions were investigated. The complex  $[\text{Rh}(\text{Fdma})_2]\text{PF}_6$  added neutral molecules such as carbon monoxide, sulphur dioxide and *t*-butyl isocyanide to give five-coordinate complexes  $[\text{Rh}(\text{L})(\text{Fdma})_2]\text{PF}_6$  (L = CO, SO<sub>2</sub>, Me<sub>3</sub>CNC). The complexes underwent addition with a variety of molecules X (X = H<sub>2</sub>, O<sub>2</sub>, Br<sub>2</sub>, I<sub>2</sub>, HCl, HBr, HI, MeSO<sub>2</sub>Cl, MeI, F<sub>3</sub>CC≡CCF<sub>3</sub>, MeSSMe) to give  $[\text{Rh}(\text{X})(\text{Fdma})_2]\text{PF}_6$ . On reaction with sulphur, S<sub>8</sub>, the complex  $[\text{Rh}(\text{S}_2)(\text{Fdma})_2]\text{PF}_6$  was produced. Reaction of the complex  $[\text{Rh}(\text{O}_2)(\text{Fdma})_2]\text{PF}_6$  with sulphur dioxide gave  $[\text{Rh}(\text{SO}_4)(\text{Fdma})_2]\text{PF}_6$ . <sup>1</sup>H NMR studies indicated that several of the five coordinate adducts were fluxional and that rearrangements occurred via opening of a chelate ring [129]. The chiral ferrocenyl-phosphine (R)-(S)-(8.36) was used to prepare the rhodium complex  $\{\text{Rh}(\text{COD})[(\text{R})-(\text{S})-(8.36)]\}^+ \text{ClO}_4^-$  which catalysed the asymmetric hydrogenation of carbonyl compounds. For example, hydrogenation of acetophenone, in the presence of the rhodium catalyst, was rapid and quantitative to give (R)-1-phenylethanol with an optical purity of 40% [130].

Irradiation of triferrocenylphosphine with excess pentacarbonyl-iron for five hours gave tetracarbonyltriferrocenylphosphineiron whilst irradiation for twenty four hours gave dicarbonyltris-(triferrocenylphosphine)iron. The conversion of the mono-substituted complex to the tris-complex was shown to proceed by a disproportionation process. The thermally initiated reaction of triferrocenylphosphine with ( $\eta$ -butadiene)tricarbonyliron gave

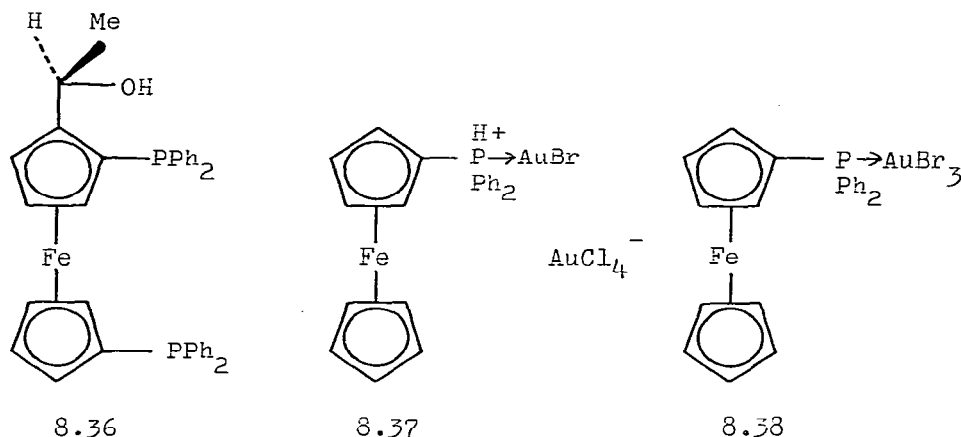

dicarbonyltris(triferrocenylphosphine)iron which was structurally different from the product obtained photochemically. The possible structures of these two isomers were discussed [131]. Gold (III) bromide was reduced with sulphur dioxide and potassium bromide in ethanol and then treated either with triferrocenylphosphine or with ferrocenyldiphenylphosphine to give the corresponding gold (I) complexes. Treatment of gold (I) bromide-ferrocenyl-diphenylphosphine with hydrogen tetrachloroaurate gave the complex (8.37) and treatment of the same gold complex with bromine gave the gold (III) complex (8.38) [132].

#### (iv) General Chemistry

A mixture of sodium cyclopentadienide and the salt  $\text{Na}^+\text{B}_5\text{H}_8^-$  in tetrahydrofuran was treated with iron (II) chloride to give ferrocene and a ferraborane,  $2-(\eta\text{-C}_5\text{H}_5)\text{FeB}_5\text{H}_{10}$ , which underwent thermal rearrangement to a sandwich isomer,  $1-(\eta\text{-C}_5\text{H}_5)\text{FeB}_5\text{H}_{10}$ , which was isoelectronic and isostructural with ferrocene [133]. ( $\eta$ -Cyclopentadienyl)iron dicarbonyl iodide was attacked by thallium (I) tricyanovinylcyclopentadienide (8.39) to form the tricyanovinylferrocene (8.40), and in the presence of an excess

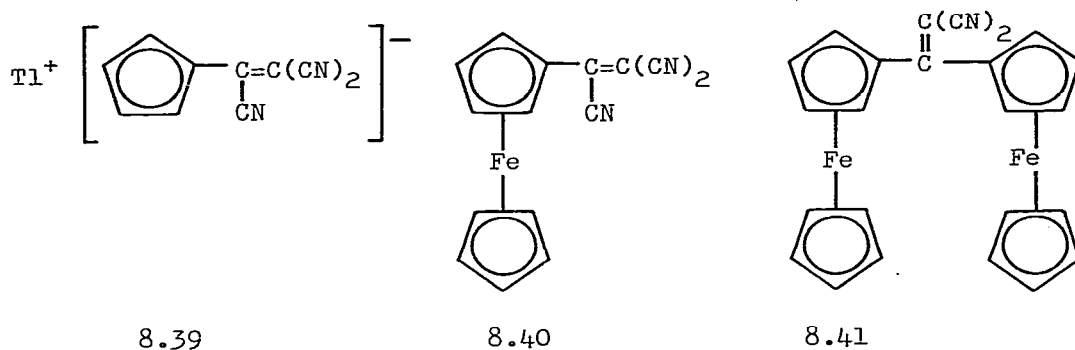

of the thallium salt, the diferrocenylethene (8.41) [134]. Electrochemical reduction of the triferrocenylcyclopropenium ion (8.42) afforded hexaferrocenylbicyclopropenyl (8.43) which aromatized easily at room temperature to the isomeric hexaferrocenylbenzene. The cation (8.42) was reduced with sodium borohydride to triferrocenylcyclopropene (8.44). Reduction also took place with sodium in liquid ammonia although on removing the solvent the reaction was reversed and the original cation (8.42) was recovered [135]. Heating the pyrylium salt (8.45) with ferrocene gave the pyrylferrocene cation (8.46;  $X = \text{O}^+$ ) and subsequent treatment of this product with ammonia gave the pyridylferrocene (8.46;  $X = \text{N}$ ) [136].

The synthesis of the cross-conjugated three-ring hydrocarbon (8.47) was attempted. Success in preparing a stable derivative of the hydrocarbon (8.47) required the presence of strong electron-withdrawing substituents or metal coordination on the five-membered ring to give the ferrocene derivative (8.48). *p*-Ferrocenylphenylmagnesium bromide (8.49) was used to prepare (Scheme 8.1) the stable ferrocene derivative (8.48) [137]. Ethylferrocene was sulphonated with an equimolar proportion of dioxane-sulphur trioxide in dichloroethane at  $-10^\circ\text{C}$  to give the monosulphonic acid (8.50;  $\text{R} = \text{H}$ ). When a two-fold molar excess of the sulphonating agent was used then the heteroannular disulphonic acid (8.50;  $\text{R} = \text{SO}_2\text{H}$ ) was obtained [138]. The ferrocene derivatives (8.51;  $\text{R}^1 = \text{H}, \text{CHO}, \text{CN}, \text{COCH}_3, \text{R}^2 = \text{H}$ ) were sulphonated to give the corresponding



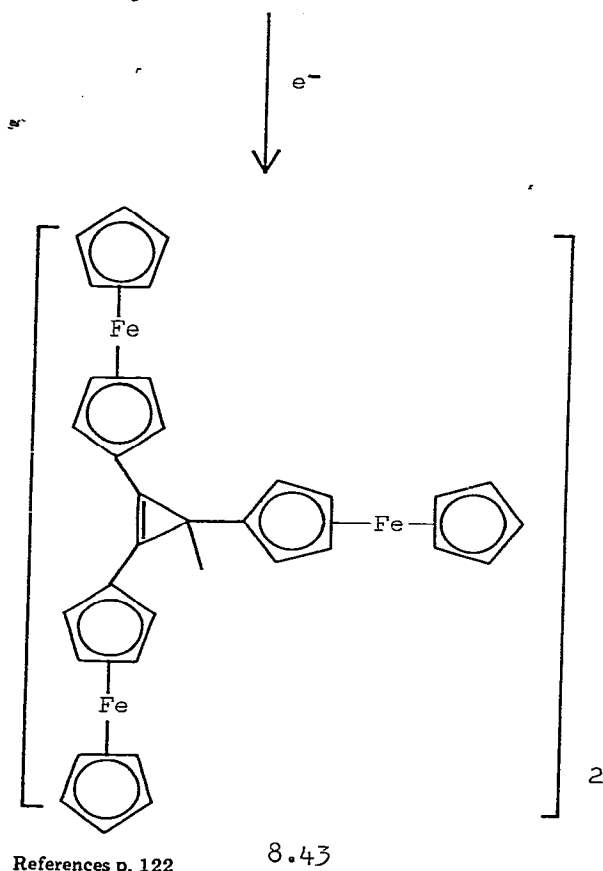
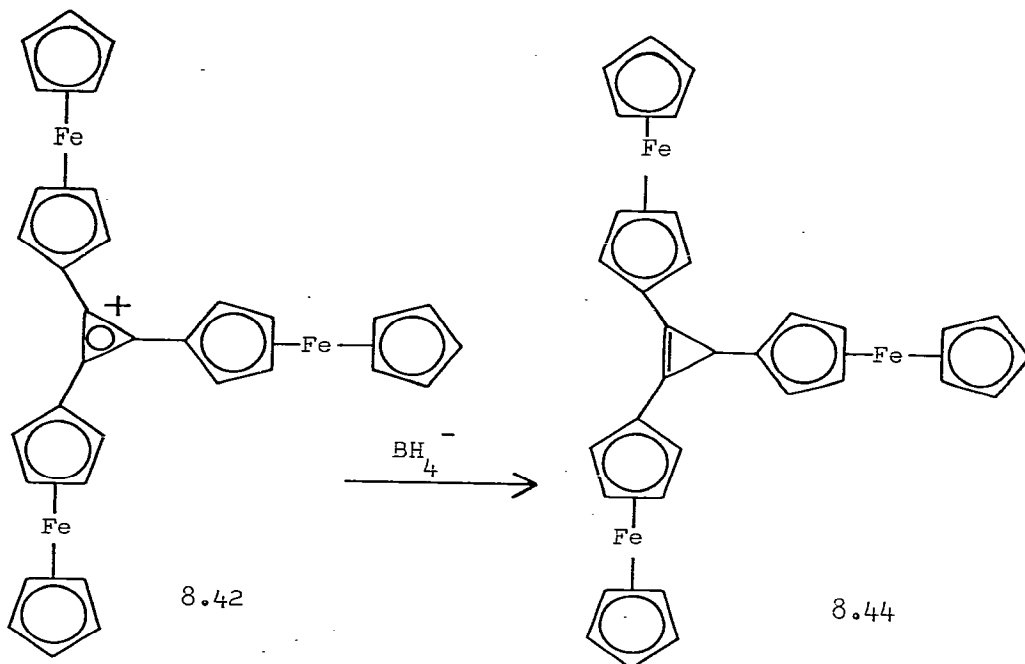

References p. 122

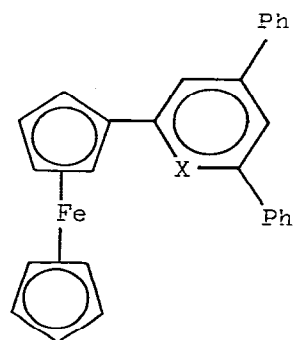
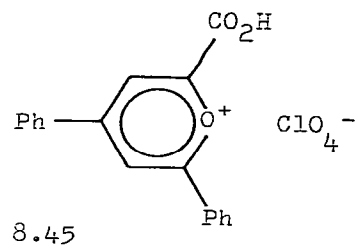

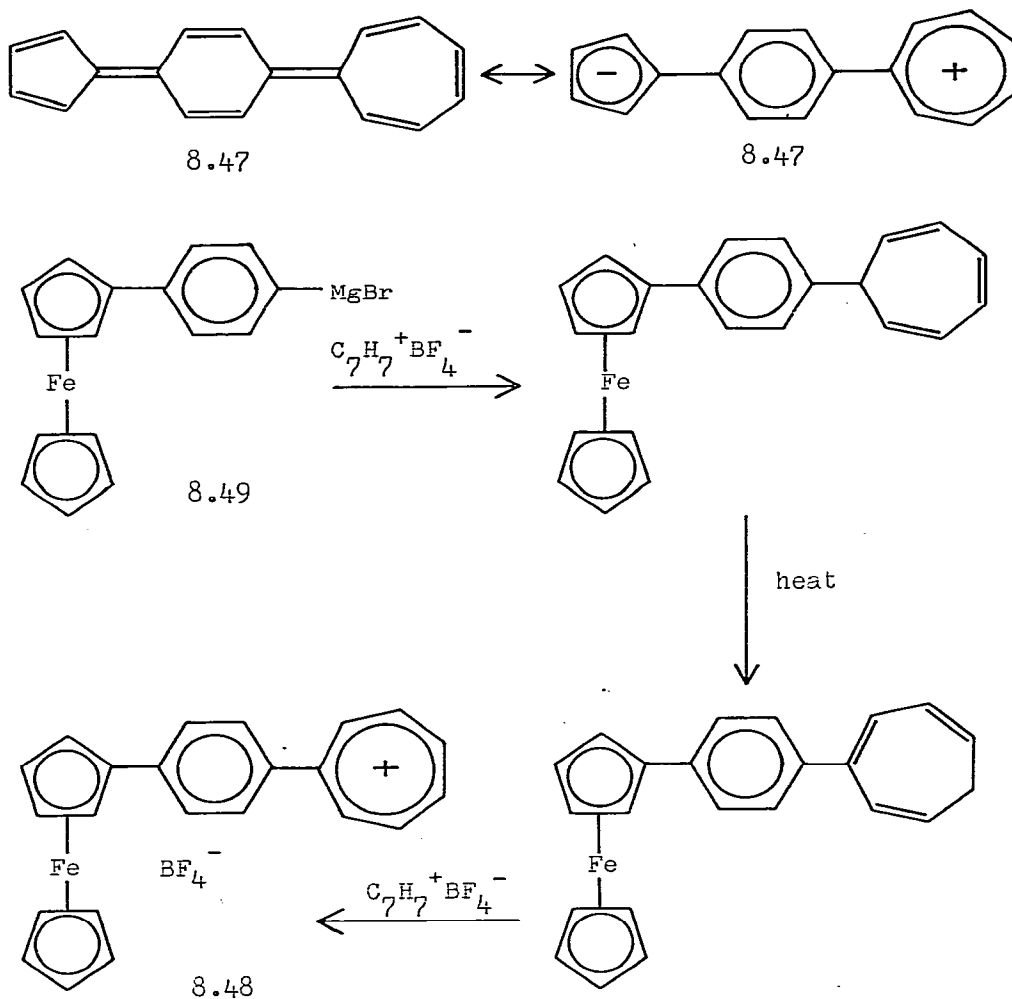

Scheme 8.1

sulphonic acids (8.51;  $R^1 = H, CHO, CN, COCH_3, R^2 = SO_3H$ ). Treatment of ferrocenesulphonic acid with phosphorus (V) or phosphorus (III) chloride gave the acid chloride which when treated with sodium methoxide or ethoxide and the amines  $HNR^1R^2$  gave the corresponding ferrocene derivatives [8.52;  $R^3 = OMe, OEt, NR^1R^2, R^1 = R^2 = H, Et, Me, OEt, R^1 = H, R^2 = Ph, naphthyl, R^1R^2 = (CH_2)_5, (CH_2CH_2)_2O$ ] [139].

Benzaldehydes were condensed with 1,1'-diethylferrocene to form the benzylferrocenes (8.53;  $R = H, p\text{-OMe}, o\text{-OH}, p\text{-F}, p\text{-Cl}, m\text{-}, p\text{-NO}_2$ ) [140]. Treatment of alkylferrocenes with

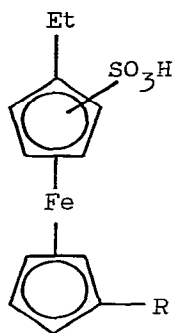

8.50

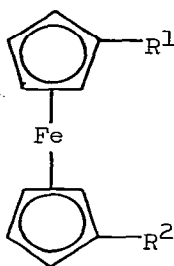

8.51

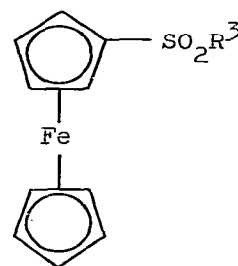

8.52

formaldehyde and methanol in the presence of sulphuric acid gave the bis(ferrocenyl)methanes (8.54; R = Bu, Et) [141].

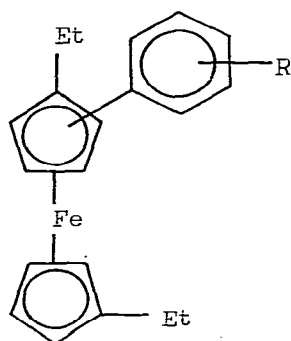

8.53

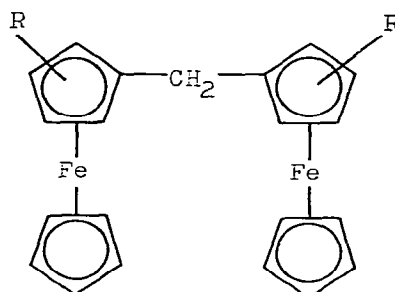

8.54

Iodoferrocene combined with acetylene in the presence of palladium (II) acetate to form diferrocenylacetylene. When the reagent was phenylacetylene then the product was ferrocenylphenylacetylene. Alkenylferrocenes were obtained in the same way by using olefins as the reagents [142]. The ferrocenylacetylenes [8.55;  $R^1 = \text{Me}$ ,  $R^2 = \text{Me, Et}$ ;  $R^1 = R^2 = \text{Pr}$ ;  $R^1R^2 = (\text{CH}_2)_4, (\text{CH}_2)_5$ ] were reduced with hydrogen over palladium to the corresponding ferrocenylbutanediols (8.56) and then dehydrated to the tetrafuranylferrocenes (8.57) [143].

Cyclization of the ferrocenyl-acetylenes (8.58;  $n = 15, 16$ ) with sodium hydrogen sulphide gave the corresponding thiophene derivatives (8.59;  $n = 15, 16$ ) [144]. Condensation of

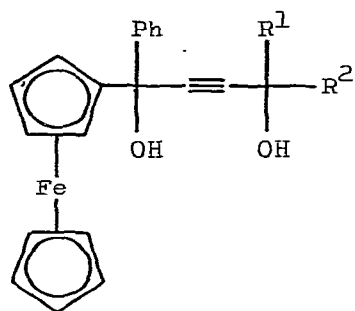

8.55

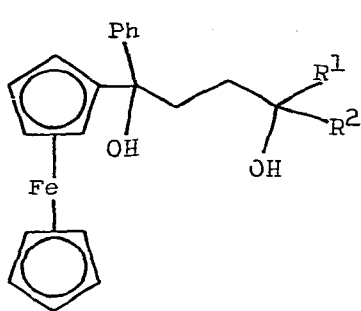

8.56

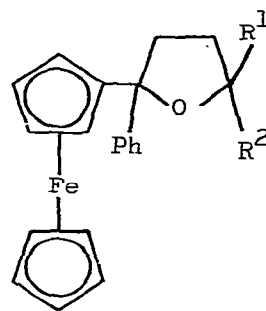

8.57

p-ferrocenylphenylpropargyl ether with m-IC<sub>6</sub>H<sub>4</sub>OCH<sub>2</sub>C≡CBr in the presence of copper (I) chloride and propylamine gave 1-(p-ferrocenylphenoxy)-6-(m-iodophenoxy)-2,4-hexadiyne [145].

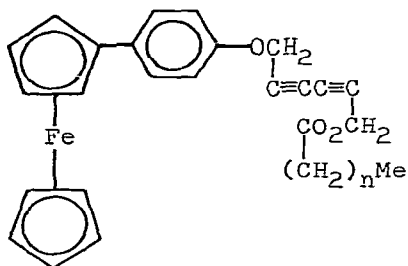

8.58

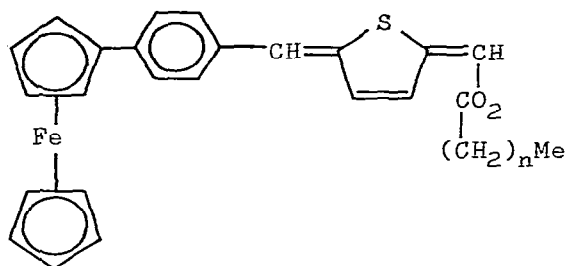

8.59

2-[(p-Ferrocenylphenoxy)methyl]-5-(phoxymethyl)thiophene was prepared by the cyclization of 1-(p-ferrocenylphenoxy)-6-phenoxy-2,4-hexadiyne with sodium hydrogen sulphide in acetone-ethanol [146]. The phenyl-ferrocene derivative (8.60) was prepared by condensing 2-propynyl nicotinate with the ferrocenyl-acetylene (8.61) in the presence of copper (II) acetate [147].

The carbamate-containing derivative of ferrocene [8.62; Z = (CH<sub>2</sub>)<sub>6</sub>] was prepared by condensing (BrC≡CCH<sub>2</sub>O<sub>2</sub>CNH)<sub>2</sub>Z with the ferrocenyl-acetylene (8.61) in the presence of copper (I) chloride and propylamine [148]. Vinylferrocene (8.63) and the

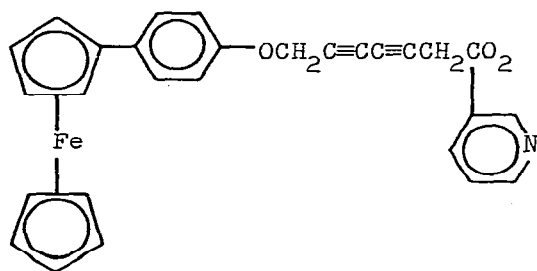

8.60

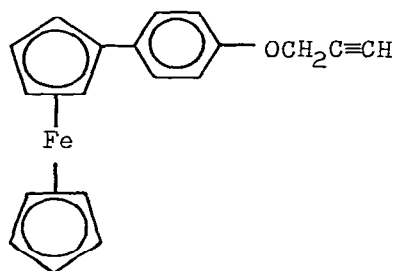

8.61

ferrocenyl-olefins (8.64 and 8.65) were reduced by molybdenum carbonyl in aqueous diglyme to give ethylferrocene and the

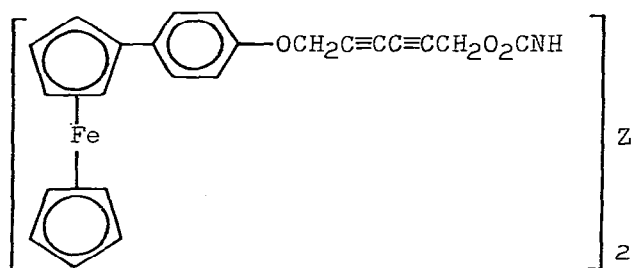

8.62

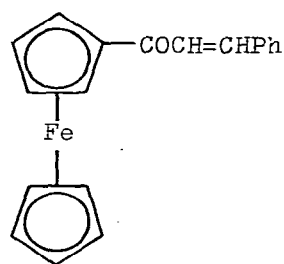

8.64

ferrocenyl-ketones (8.66 and 8.67) respectively [149]. Vinylferrocene (8.63) underwent cycloaddition with tetracyanoethylene to give the ferrocenylcyclobutane (8.68) [150]. The reduction of ferrocene containing acetylenic  $\gamma$ -glycols with an aluminium chloride-lithium aluminium hydride mixture has been investigated [151].

Ferrocenecarbaldehyde was condensed with 1-phenyl-3-methyl-2-pyrazolin-5-ones to form the ferrocenyl pyrazolinones (8.69; R = H, NO<sub>2</sub>), the monomethine cyanine dyes (8.70; R = H, NO<sub>2</sub>) were obtained by similar condensations [152]. The ferrocenyl-

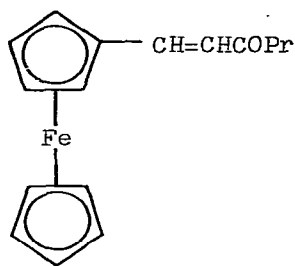

8.65

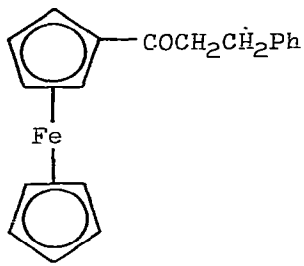

8.66

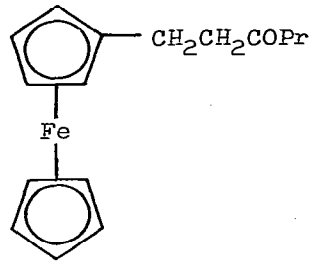

8.67

pyrilium salts (8.72;  $R^1 = \text{Me, Ph, OEt}$ ,  $R^2 = \text{Me, Ph}$ ) were formed by condensation of  $\beta$ -diketones ( $R^1\text{COCH}_2\text{COR}^2$ ) with  $\beta$ -chloro-

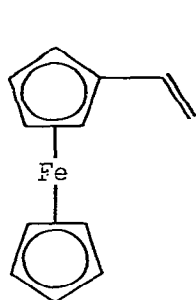

8.63

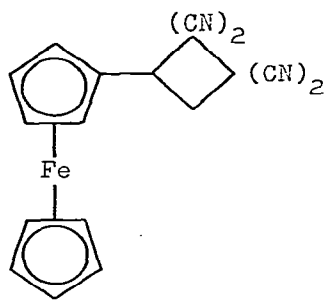
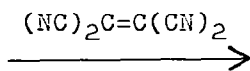

8.68

$\beta$ -ferrocenylacrylaldehyde (8.71) and subsequent addition of perchloric acid. These products were converted to the ferrocenylpyridines (8.73;  $R^1 = \text{Me, Ph, OEt}$ ,  $R^2 = \text{Me, Ph}$ ) by heating with ammonium acetate in acetic acid [153]. The mechanism of the condensation of formyl- and acetyl-ferrocene with acetone cyanohydrin and amines to give the ferrocenylalkylamines (8.74;  $R^1 = \text{H, Me}$ ;  $R^2 = \text{H, Me, MeO, Br, NO}_2, \text{p-H}_2\text{NC}_6\text{H}_4$ ) was determined. The acylferrocene condensed with the amine to give an imine and this then reacted with the cyanohydrin to yield the product [154].

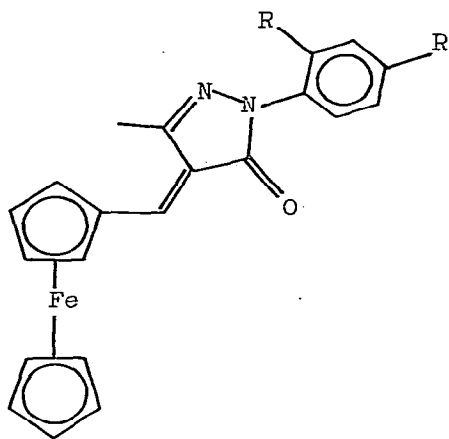

8.69

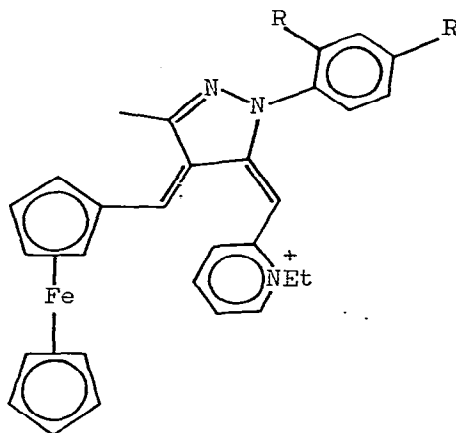

8.70

The reactions of acetylferrocene and formylferrocenes with  $\text{Me}_2\text{C}(\text{OH})\text{CN}$ , secondary amines, cyclopentadiene and sodium phos-

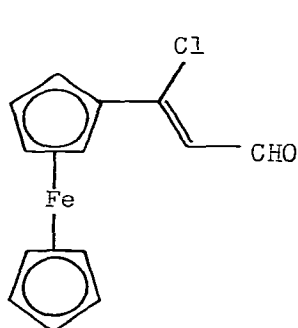

8.71

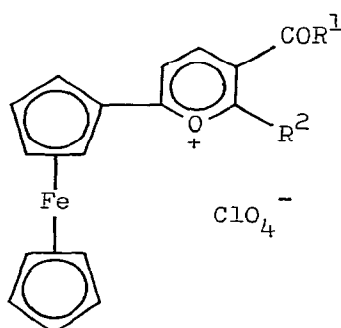

8.72

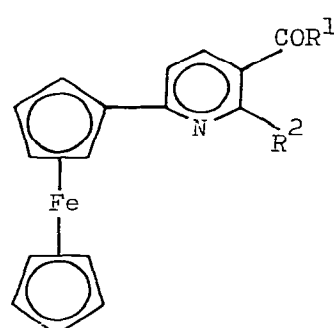

8.73

phonates have been investigated. For example, the treatment of formylferrocene with  $\text{Me}_2\text{C}(\text{OH})\text{CN}$  gave the hydroxy-cyanide (8.75) [155]. The ferrocenylketoximes (8.76;  $\text{R} = \text{Me}, \text{Et}, \text{Pr}, \text{Ph}$ ) underwent the Beckmann rearrangement to give the ferrocenylamides (8.77;  $\text{R} = \text{Me}, \text{Et}, \text{Pr}, \text{Ph}$ ) which were reduced to the secondary amines (8.78;  $\text{R} = \text{Me}, \text{Et}, \text{Pr}, \text{Ph}$ ) in high yield [156]. Acetylferrocene combined with 1,3,5-trinitrobenzene in the presence of triethylamine to give the salt (8.79) which on treatment with tropylium tetrafluoroborate in acetonitrile aromatised to form the trinitrophenyl derivative (8.80) [157].

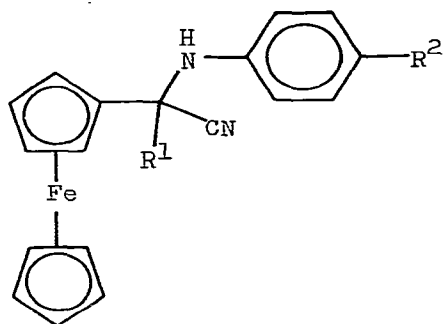

8.74

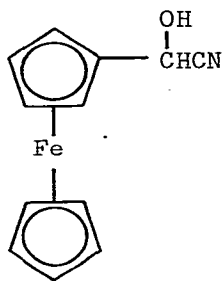

8.75

A series of ferrocenyl dioxolanes (8.81;  $R^1 = R^3 = H$ ,  $R^2 = Me$ ,  $X^1 = X^2 = O$ ;  $R^1 = H$ ,  $R^2 = R^3 = Me$ ,  $X^1 = X^2 = O$ ),

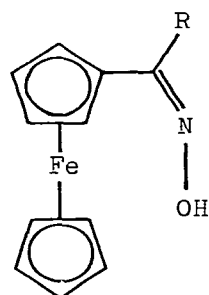

8.76

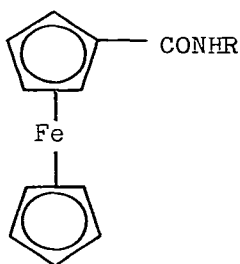

8.77

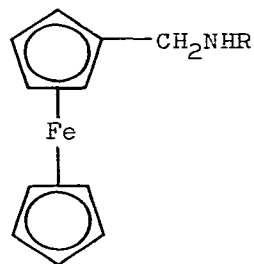

8.78

oxathiolanes (8.81;  $R^1 = R^2 = R^3 = H$ ,  $X^1 = O$ ,  $X^2 = S$ ;  $R^1 = Me$ ,  $R^2 = R^3 = H$ ,  $X^1 = O$ ,  $X^2 = S$ ;  $R^1 = Ph$ ,  $R^2 = R^3 = H$ ,  $X^1 = O$ ,  $X^2 = S$ ) and dithiolanes (8.81;  $R^1 = R^2 = R^3 = H$ ,  $X^1 = X^2 = S$ ;  $R^1 = Me$ ,  $R^2 = R^3 = H$ ,  $X^1 = X^2 = S$ ;  $R^1 = Ph$ ,  $R^2 = R^3 = H$ ,  $X^1 = X^2 = S$ ), (8.82;  $R = Me$ ;  $R = Ph$ ) were prepared by the reaction of formylferrocene or a ferrocenylketone with 1,2-diols, 2-mercaptoethanol or 1,2-dimercaptoethane (Scheme 8.2). All the compounds were relatively unstable and the rates of decomposition decreased in the order: dioxolanes > oxathiolanes > dithiolanes [158]. Reaction of formylferrocene with hydrogen sulphide in ethanol saturated with hydrochloric acid gas gave a mixture of the



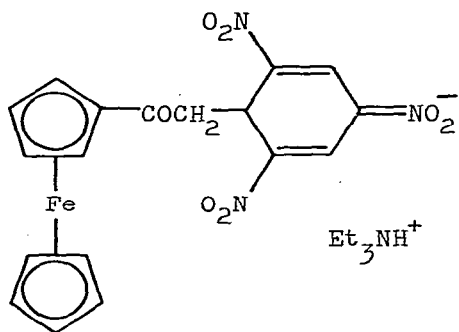

8.79

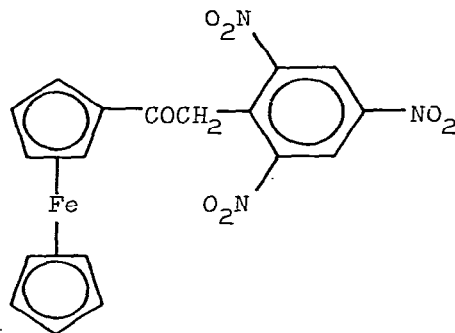

8.80

stereoisomeric 2,4,6-triferrocenyl-1,3,5-trithiacyclohexanes (8.83 and 8.84). Whereas treatment of formylferrocene with sodium thiosulphate gave mainly one isomer (8.83) [159].

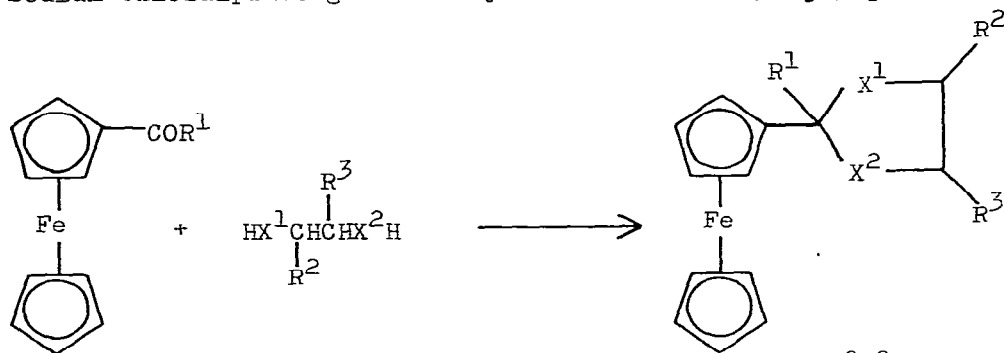

8.81

Scheme 8.2

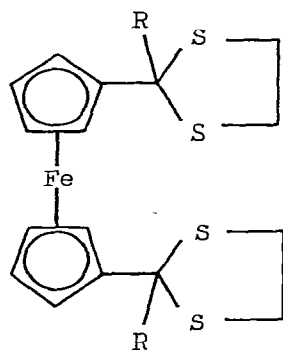

8.82

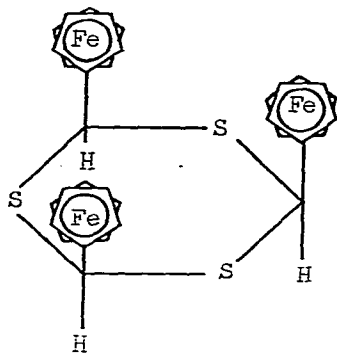

8.83

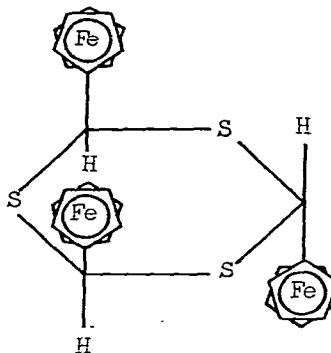

8.84

The reaction of formylferrocene and acetylferrocene with zirconocene hydrochloride gave ferrocenemethanol and 2-ferrocenylpropan-2-ol respectively. In a similar reaction ferrocenecarboxylic acid was reduced to ferrocenemethanol. The reduction of the alcohols was shown to proceed via a ferrocene-zirconocene complex (8.85; R = H, Me) [160].

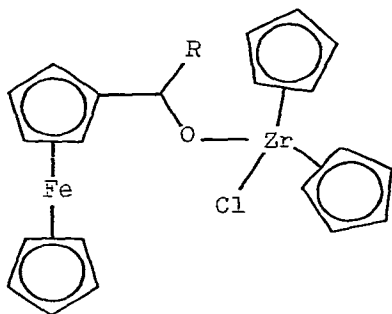

8.85

Kalennikov has investigated the role of catalysts in the synthesis of 2-ferrocenyl-4-methyl-5,6-benzoquinoline (8.87). Optimal yields were obtained from the imine (8.86) and acetone in the presence of aluminium chloride as catalyst [161]. The reduction of 1,1'-diacylferrocenes to the corresponding dialkylferrocenes with sodium borohydride and aluminium chloride in dimethoxyethane and diglyme has been reported. Typical

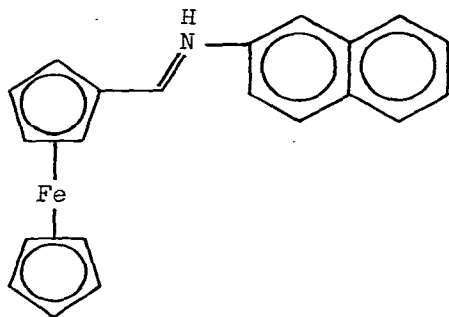

8.86

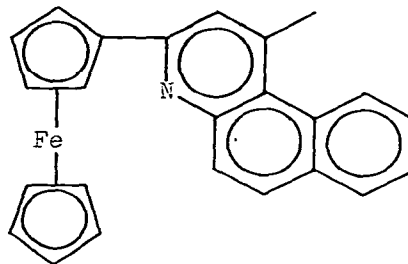

8.87

compounds prepared were the alkylferrocenes (8.88;  $R^1 = H, \text{alkyl}, \text{aryl}$ ,  $R^2 = \text{aralkyl}, \text{aryl}$ ) [162]. A related patent described the reduction of ferrocenophanes containing  $\alpha$ -keto or  $\alpha$ -hydroxy groups to ferrocenophanes under the same conditions [163].

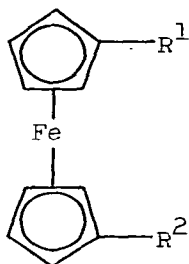

8.88

Reduction of the ferrocenyl-indanones (8.89;  $X = H, Cl$ ) with potassium and sodium borohydrides and Grignard reagents was stereospecific with the endo-isomer (8.90;  $X = H, Cl$ ) being produced. The stereoselectivity was more than 95%, lithium aluminium hydride was less stereoselective with both the endo- (8.90;  $X = H$ ) and exo- (8.91) alcohols being produced [164].

A series of alkyl and aralkyl ferrocenes was prepared by reducing ferrocenyl-ketones and  $\alpha$ -hydroxyferrocenes with sodium borohydride in the presence of boron trifluoride etherate [165]. Ferrocenylcarbinols (8.92;  $R = H, Me, Et, Pr^i, Ph$ ) were treated with thioglycollic acid and 2-hydroxyethanethiol to give the

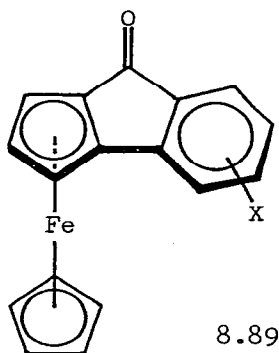

8.89

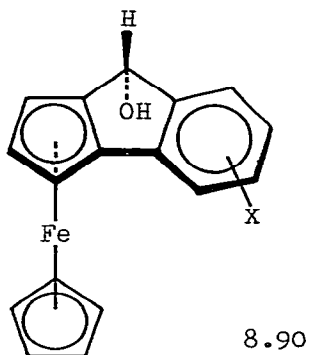

8.90

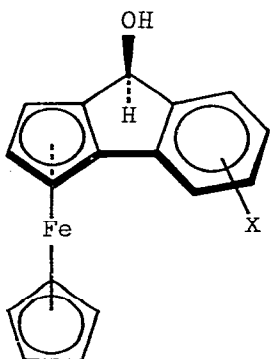

8.91

corresponding carboxylic acids and alcohols (8.93;  $R^1 = \text{H, Me, Et, Pr}^1, \text{Ph}$ ,  $R^2 = \text{CO}_2\text{H, CH}_2\text{OH}$ ). The hydrolysis of some ferrocenophane thioglycollic acids was also described [166]. Reaction of 1,1'-dihydroxymethylferrocene and 1,1'-di- $\alpha$ -hydroxyethylferrocene with 1,2-ethanedithiol gave the bridged ferrocene

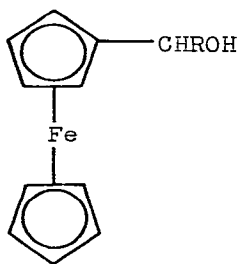

8.92

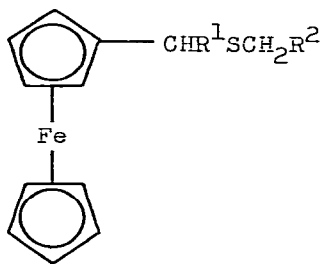

8.93

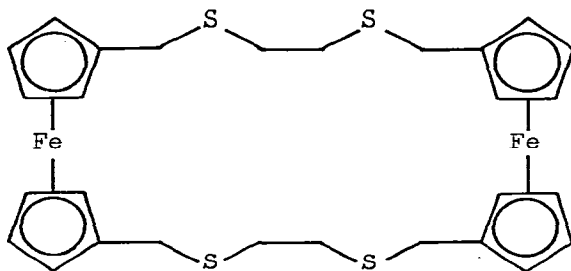

8.94

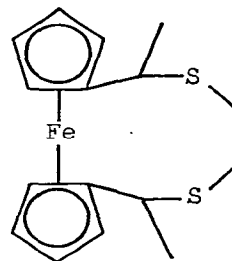

8.95

derivatives (8.94 and 8.95) respectively [167]. The reaction of 1,1'-bis(hydroxymethyl)ferrocene with  $p\text{-MeC}_6\text{H}_4\text{SO}_2\text{Cl}$  gave the pyridinium salt (8.96). Treatment of this salt (8.96) with  $\text{LiC}(\text{NO}_2)\text{R}^1\text{R}^2$  ( $\text{R}^1 = \text{H}, \text{Me}, \text{NO}_2$ ;  $\text{R}^2 = \text{Me}, \text{CO}_2\text{Me}, \text{Et}, \text{CH}_2\text{CH}_2\text{CO}_2\text{Me}, \text{CH}_2\text{CH}_2\text{OCOMe}$ ) and  $\text{LiN}(\text{NO}_2)\text{R}$  ( $\text{R} = \text{Me}, \text{CH}_2\text{CH}_2\text{CN}$ ) gave the corresponding bis(nitroalkyl) (8.97) and bis(nitroaminoalkyl) (8.98)

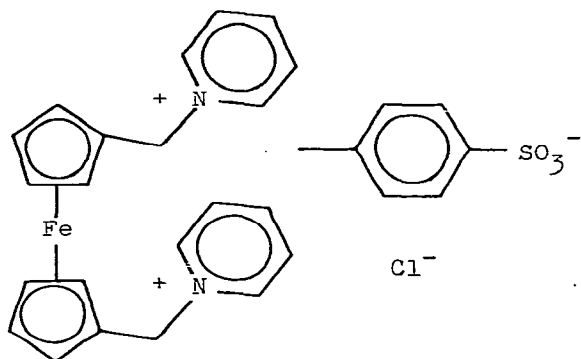

8.96

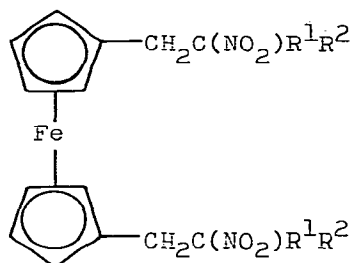

8.97

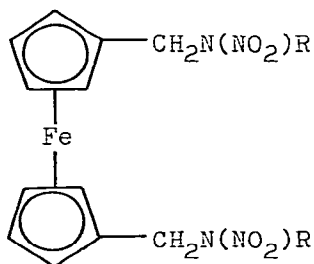

8.98

derivatives of ferrocene respectively [168].

The kinetics of reaction of the quaternary salt (8.99) with  $RCH_2C(NO_2)_2K$  ( $R = H, Me, CH_2CN, CH_2COMe, CH_2CO_2Me$ ) were determined in 50% water-methanol. Displacement occurred to give the ferrocenylmethyl derivatives (8.100) together with some hydrolysis of the starting salt (8.99) [169]. Ferrocenylamine was condensed

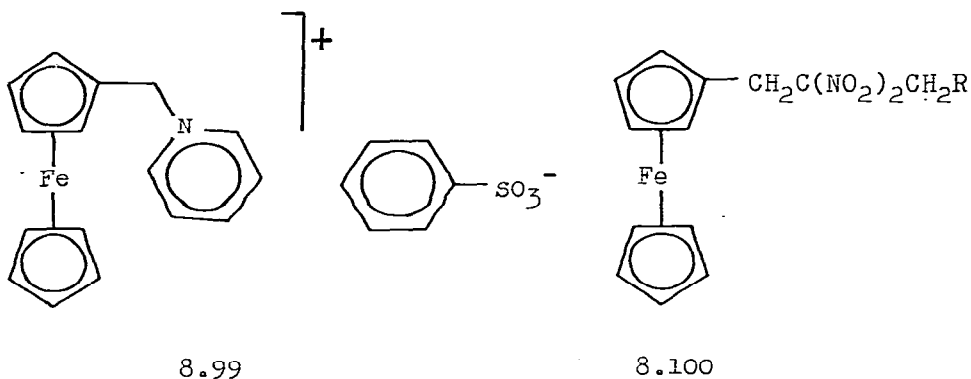

with a series of aldehydes  $RCHO$  ( $R = Ph, p-NO_2C_6H_4, p-Me_2NC_6H_4, 2-furyl, 5-nitro-2-furyl, PhCH=CH$ ) to give the corresponding azomethines (8.101) [170]. The thermal decomposition of ferrocenylmethyl-*N*-nitroamines [8.102;  $R = H, CH_2CH_2CN, CH_2CH_2CMe(NO_2)_2$ ] has been the subject of a kinetic investigation [171]. The ferrocene acids (8.103;  $R = Me, Me_2CH$ ) were

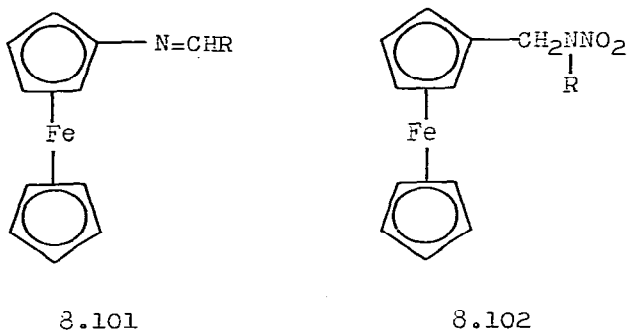

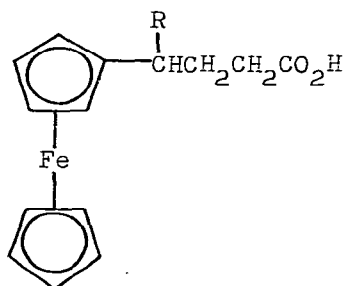

8.103

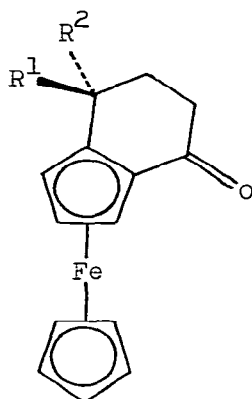

8.104

cyclized to give the ketones (8.104;  $R^1 = \text{Me}, \text{Me}_2\text{CH}, R^2 = \text{H}; R^1 = \text{H}, R^2 = \text{Me}, \text{Me}_2\text{CH}$ ). Reduction of the ketones (8.104) gave the corresponding exo- and endo-alcohols [172].

Reaction of ferrocenecarboxylic acid chloride with sodium hydrogen sulphide gave ferrocenethiocarboxylic acid (8.105). Treatment of the thiocarboxylic acid (8.105) with amines such as piperidine and trimethylamine gave the corresponding air stable piperidinium and trimethylammonium ferrocenethiocarboxylates. These salts reacted readily with a variety of electrophilic reagents to give the corresponding esters. For example, reaction with triphenyltin chloride gave the ester (8.106) [173]. Aldehydes were condensed with p-ferrocenyl-carboxyaniline to form the mesomorphic ferrocene derivatives

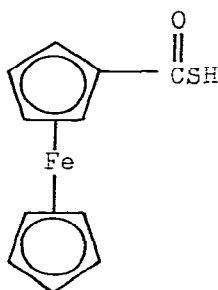

8.105

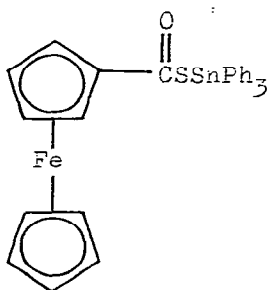

8.106

(8.107;  $n = 4, 5, 7$ ). Several related derivatives were also described [174]. Treatment of the S-(1-ferrocenylalkyl)thio-

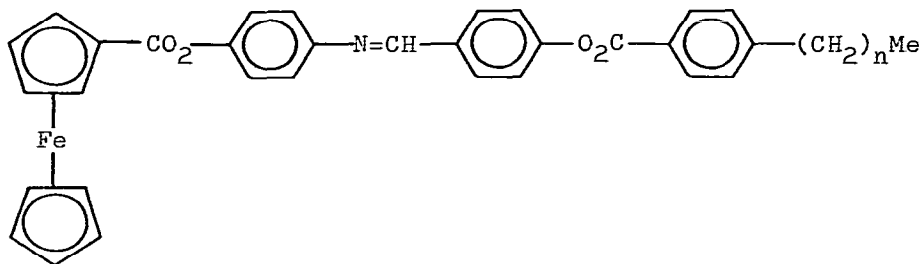

8.107

glycolic acids (8.108;  $R^1 = H, Me$ ) with mercury (II) chloride and an amine gave the corresponding ferrocenylalkyl-amines [8.109;  $R^2 = H, R^3 = PhCH_2, cyclohexyl; R^2, R^3 = (CH_2)_4$ ] [175].

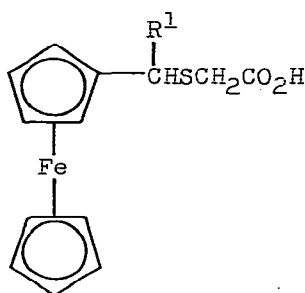

8.108

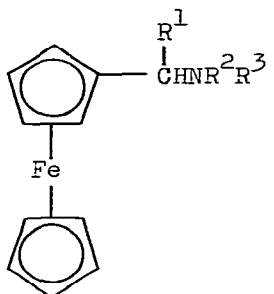

8.109

## 9. BIFERROCENES, FERROCENOPHANES AND ANNELATED FERROCENES

The stereospecific lithiation of the ferrocenophane (9.1;  $A = H, X = NMe_2, Y = H$ ) was used to prepare some chiral ferrocenes. For example, condensation of the lithiated intermediate with methyl iodide, dimethylformamide and benzonitrile gave the [3]ferrocenophanes (9.1;  $A = Me, X = NMe_2, Y = H$ ), (9.1;  $A = CHO, X = NMe_2, Y = H$ ) and (9.1;  $A = CPh, X = NMe_2, Y = H$ ) respectively. These ferrocenophanes were used to study the



stereochemistry of substitution of groups bonded to the  $\alpha$ -carbon atom of the bridge. It was found that nucleophilic substitution proceeded with retention whereas metallation caused racemisation [176]. Methyl 1'-acetylferrocenecarboxylate was cyclized in

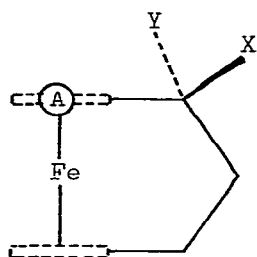

9.1

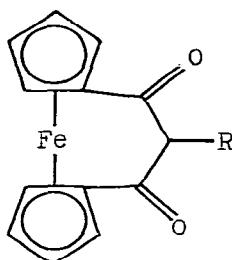

9.2

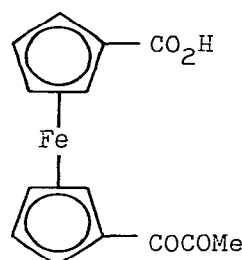

9.3

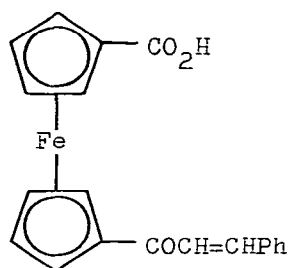

9.4

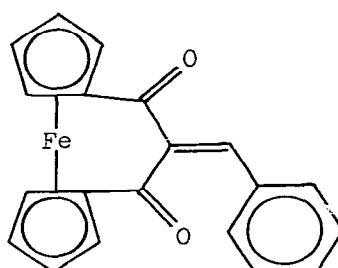

9.5

the presence of potassium triphenylmethoxide to give [3]ferrocenophane-1,3-dione (9.2; R = H). 2-Substituted [3]ferrocenophane-1,3-diones (9.2; R = Me, Ph) were prepared by the same route. A solution of the 2-methyl derivative (9.2; R = Me) was rapidly oxidized by air to give the carboxylic acid (9.3). Condensation of the dione (9.2; R = H) with benzaldehyde in the presence of sodium hydroxide gave 1'-cinnamoylferrocenecarboxylic acid (9.4) whilst in the presence of triethylamine the dione (9.5) was isolated [177].

Condensation of 2-formyl[4](1,1')ferrocenophane (9.6) with malonic acid gave an acylferrocenophane which was reduced to give the saturated carboxylic acid (9.7). Treatment of the acid (9.7) with trifluoroacetic acid anhydride gave three cyclization products (9.8, 9.9 and 9.10). Similar reactions were carried out to prepare the ferrocenophanes (9.11, 9.12 and 9.13). Some reactions of these multibridged ferrocenophanes

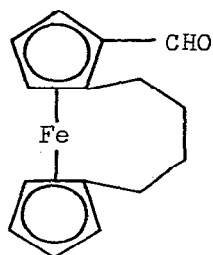

9.6

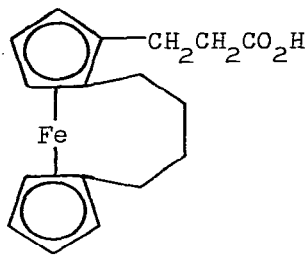

9.7

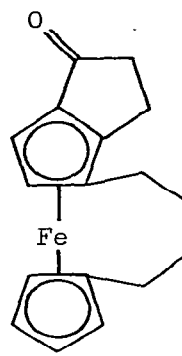

9.8

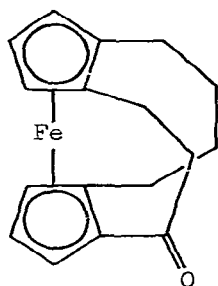

9.9

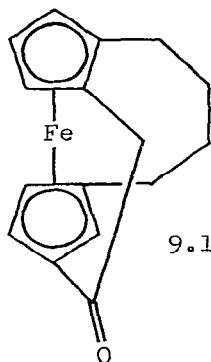

9.10

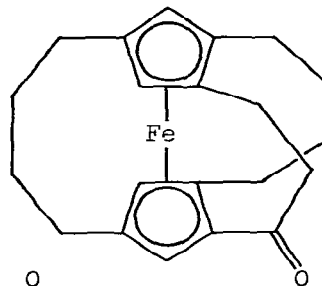

9.11

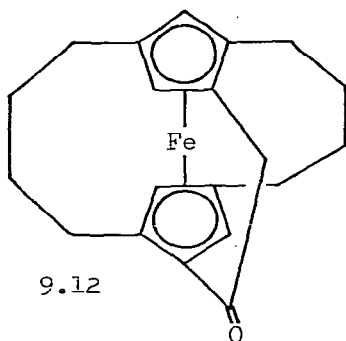

9.12

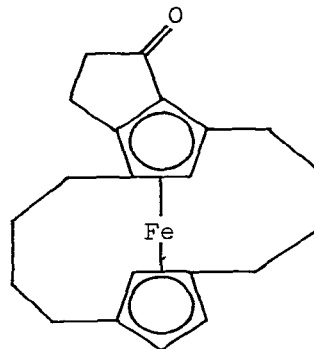

9.13

were described [178]. The mass spectrometric fragmentation of several [3]- and [4]-ferrocenophane ketones has been reported. Decarbonylation was accompanied by bridge contraction in some cases [179]. The isomeric [4][4][4][3]ferrocenophanes (9.14 and 9.15) have been prepared by cyclization of the appropriate tribridged ferrocenophanes. One isomer (9.14) was converted to the butyric acid (9.16) which may be regarded as a precursor for a pentabridged ferrocenophane [180].

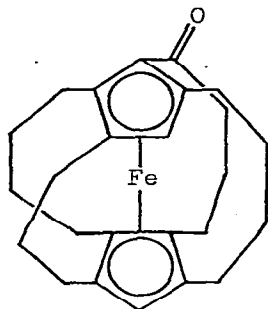

9.14

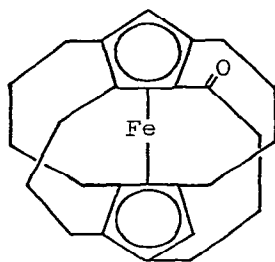

9.15

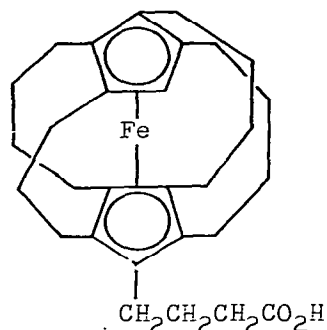

9.16

The [5]ferrocenophane diketones (9.17; R = H, Ph) and the [5]ferrocenophane ether (9.18) were each reduced to the pentamethylene ferrocenes (9.19; R = H, Ph) with a mixture of sodium borohydride and aluminium chloride [181]. The crystal

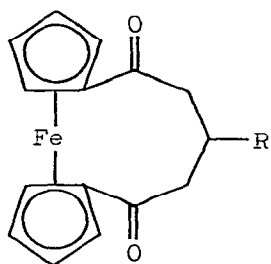

9.17

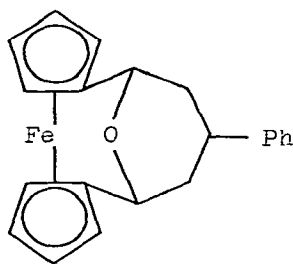

9.18

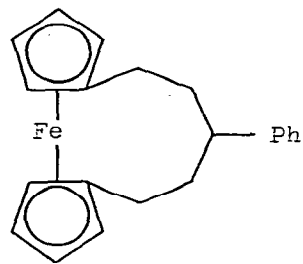

9.19

and molecular structure of 3,4'-diacetyl[5]ferrocenophane has been determined by single crystal X-ray analysis. The cyclopentadienyl rings deviate from the eclipsed position by  $17.4^\circ$  [182]. Roling and Rausch have examined the Ullmann reaction of 1,2-diiodoferrocene as a single reactant and in admixture with iodoferrocene. In each case the same complex range of 1,2-oligomeric ferrocenes was obtained which included biferrocene (9.20) the terferrocene (9.21) two quaterferrocenes (9.22 and 9.23) and the quinqueferrocene (9.24). The 1,2-terferrocene (9.21) was polymorphic and crystallized in four different

forms. The lower melting 1,2-quaterferrocene (9.22) was assigned as a racemic mixture of two enantiomers while the higher melting isomer (9.23) was identified as a meso-1,2-quaterferrocene. The quinqueferrocene (9.24) showed similar physical properties to

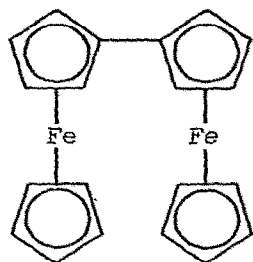

9.20

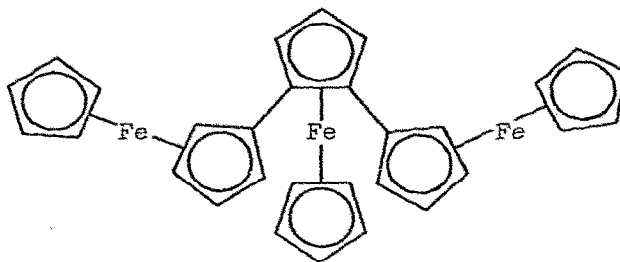

9.21

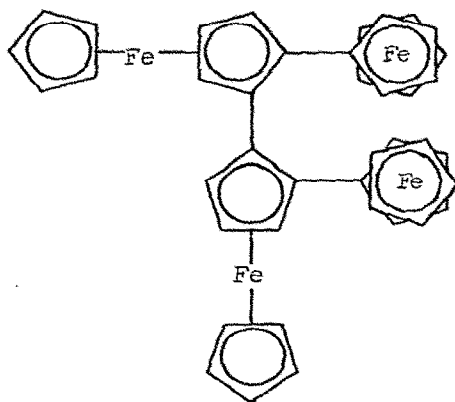

9.22

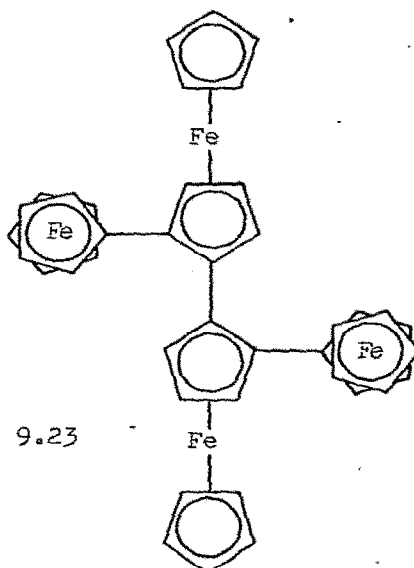

9.23

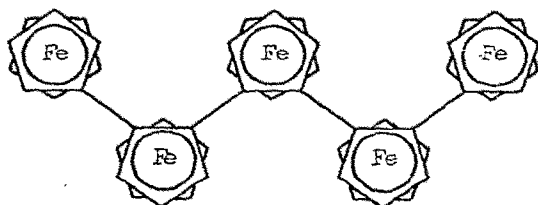

9.24

the quaterferrocene (9.23) and was assigned as meso-1,2-quinqueferrocene [183].

The diastereomeric biferrocenes (9.25 and 9.26) were synthesised from optically active starting materials which enabled the previous configurational assignments to be confirmed. A general fragmentation scheme for halogenoferrocenes was formulated on the basis of the mass spectra of seven halogenated ferrocenes [184]. The 2,6'-disubstituted biferrocenyls (9.27;  $R^1 = Et, Cl$ )

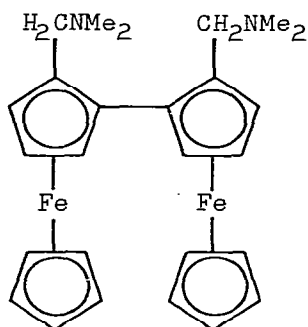

9.25

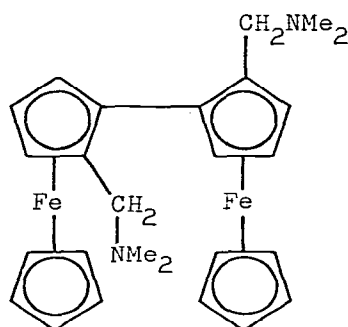

9.26

were prepared by heating 1-copper-2-dimethylaminomethylferrocene with the appropriate halide (9.28;  $R^1 = Et, Cl$ ;  $R^2 = Br, I$ ) [185].

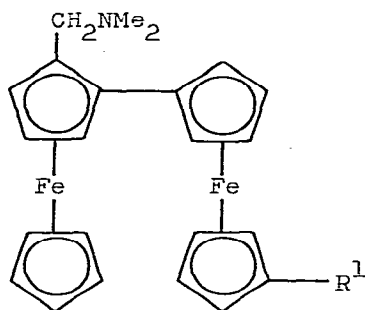

9.27

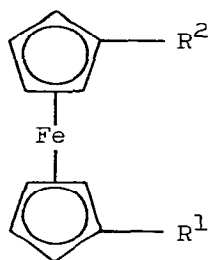

9.28

## 10. FERROCENE-CONTAINING POLYMERS

Acryloyl(ferrocene) was copolymerized with vinylacetate, styrene, acrylonitrile and methyl methacrylate. The kinetics of thermal degradation of these copolymers in air and helium was determined by thermogravimetric analysis. The introduction of ferrocene into the polymer main chain increased the thermal stability of polyacrylonitrile, polystyrene and poly(vinyl acetate). The thermal stability of poly(acryloylferrocene) homopolymer was also investigated [186]. A series of resins was prepared by the polycondensation of acetylferrocene and furfural using sulphuric acid as the catalyst. When the molar ratio of furfural to ferrocene exceeded 15 to 1 the resin was not formed. The resins were heated under high vacuum to 350° for four hours and then up to 400° for two hours. Infrared spectra showed that the resin structure was decomposed and X-ray diffraction patterns indicated that the matrix of heat treated resin was a glass-like carbon. The iron particles with a diameter of 10-24 Å from one of the resins were uniformly dispersed in the carbon matrix with large particles (30-150 Å) thinly scattered. The size of the iron particles varied with the structure of the resin. The iron occurred in both hexagonal close packed and distorted body centred cubic forms [187]. Pyrolysis of a 1-ferrocenylethanol-formaldehyde-phenol copolymer gave a glasslike carbon matrix containing ferromagnetic iron particles. The characteristics of the iron particles were determined by ESR and Moessbauer spectroscopy and by magnetic susceptibility measurements [188].

Ferrocene residues were incorporated into terephthalate polymers by transesterification of dimethyl terephthalate and dimethyl 1,1'-ferrocenedicarboxylate with ethylene glycol followed by condensation of the resulting bis-glycol esters in vacuo at 270° to form a copolymer. Between 0.1 and 0.5 mole % ferrocene units were introduced into the copolymer which, when drawn into fibres, showed improved UV resistance over unmodified poly(ethylene terephthalate) [189]. The diethylene glycol-maleic anhydride copolymer was formed in the presence of 0.004 mole of 1,1'-dipropylferrocene and 1,1'-dibutylferrocene and after crosslinking in the presence of a peroxide catalyst at room temperature showed high mechanical strength and good thermal stability [190]. Treatment of ferrocene-aluminium chloride mixtures in 1,2-dichloroethene with polybutadiene-ferrocene mixtures resulted in incorporation of the ferrocene into the polymer. The glass

transition temperature of the polymer increased considerably with increased incorporation of ferrocene as compared with the unsubstituted polymer [191].

In a group of related patents Kato and Kan have described procedures for the polycondensation of ferrocene with aldehydes or ketones. Each of the procedures used a polar organic solvent such as dimethylformamide and a Lewis acid catalyst such as iron (III) chloride. In one case a non-polar organic solvent such as xylene was used to remove water as an azeotrope. In the second method the aldehyde or ketone was added dropwise to the hot, stirred reaction mixture. While in the third procedure the catalyst solution was added dropwise to the heated solution containing the ferrocene and carbonyl compound. The polymeric products were press moulded into sheet form [192, 193, 194]. Ferrocene polymers, such as the cyclohexanone-ferrocene copolymer, have been used as heat sensors with good thermal stability [195]. Thermal polymerization of *p*-ferrocenylphenylacetylene sulphate and  $\alpha$ -chloro- $\beta$ -formyl-*p*-ferrocenylstyrene sulphate afforded polymers which were catalysts for the oligomerization of  $\alpha$ -chloro- $\beta$ -formyl-*p*-bromostyrene and  $\alpha$ -chloro- $\beta$ -formyl-*p*-chlorostyrene. Thermal oligomerization was less efficient. The ferrocene catalysts were specific for chloroformylated vinyl monomers and the chlorostyrene was converted more effectively than the bromostyrene [196].

The anionic polymerization of ferrocenylmethacrylate (10.1) under high vacuum has been investigated by Pittman and Hirao. Ethyl and phenyl Grignard reagents, *n*-butyllithium, sodium and potassium naphthalide and lithium aluminium hydride

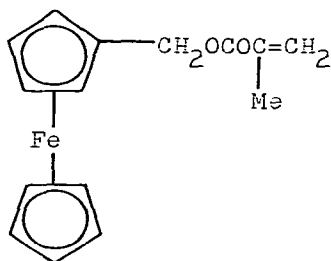

10.1

were used as initiators. Variation of the monomer to lithium aluminium hydride ratio permitted the molecular weight of the polymer to be controlled. In this way a benzene soluble polymer with  $M_n \leq 277,000$  was obtained which had a narrow molecular weight distribution [197]. Sulphur monochloride was condensed with ferrocenylphenol, ( $\alpha$ -hydroxyethyl)ferrocene and bis( $\alpha$ -hydroxyethyl)-ferrocene to form polymers containing an S-S linkage. The polymers were air stable at  $200^\circ$  [198]. The mechanism of phosphorescence quenching of triphenylene by electronic energy transfer from the lowest triplet state to ferrocene has been studied in poly(methyl methacrylate) at  $77^\circ$  K. Transfer to ferrocene occurred by a dipole-dipole mechanism with a weak transfer channel due to the polymer matrix [199].

## 11. APPLICATIONS OF FERROCENE

### (i) Ferrocene catalysts and photosensitizers

Metallocene polymers were used as the main constituents in the formulation of magnetic materials such as magnetic tapes and copying materials. For example, ferrocene, benzaldehyde, dimethylformamide and iron (III) chloride as catalyst were heated together for one hour at  $120^\circ$ . The brown copolymer that was obtained after purification had a specific magnetic permeability of 13 (measured at 60 Hz) [200]. Methanation catalysts that were resistant to contamination by sulphur were prepared from a molten zinc halide carrier, for example, zinc chloride, bromide or iodide containing a dispersed metal catalyst. The catalysts were ferrocene, pentacarbonyliron and manganese [201]. Ferrocene and some substituted ferrocenes were found to behave as catalysts in the light-assisted reaction of cyclohexyl isocyanate with n-butyl or t-butyl alcohol in carbon tetrachloride to give a carbonate. It was proposed that the reaction occurred by excited state charge-transfer complexes which involved the isocyanate and solvent or ferrocene and solvent [202]. When ferrocene was added to a photothermographic copying material it greatly increased the sensitivity [202].

A mixture of *p*-hydroxydiphenylamine, carbon tetrabromide, ferrocene and poly(methyl methacrylate) in tetrahydrofuran was coated on paper and shown to be photosensitive. Irradiation with a mercury lamp gave a black image [204]. A mixture of a ferrocenyl-ketone (11.1;  $R^1 = H, alkyl, benzyl, Ph$ ;  $R^2 = H, CN, acetyl, valeryl, p\text{-methylbenzoyl}$ ) and a diazonium salt were used



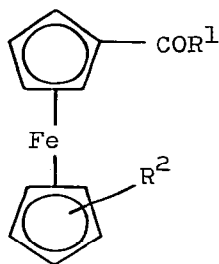

11.1

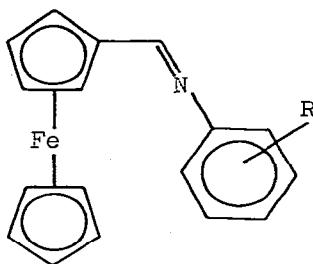

11.2

in the production of photocopying material. For example *p*-dipropylaminobenzenediazonium salt and acetylferrocene in ethylene glycol monomethyl ether were coated on paper, imagewise exposed to a mercury lamp and then exposed uniformly to infrared radiation. This gave a copy with a blue-purple background (exposed area) with yellow images (unexposed area) [205].

(ii) Ferrocene stabilizers and improvers

The azomethines (11.2; R = H, OH) behaved as UV light stabilizers when mixed with polyethylene [206]. The ferrocene-azomethines (11.2; R = H, *o*-, *m*-, *p*-OH) were useful as stabilizers for polyethylene exposed to ultraviolet irradiation [207].  $\alpha$ -Hydroxyethylferrocene was added to polyethylene as an ultraviolet light stabilizer [208]. Addition of (naphthylamino-methyl)ferrocene to polyethylene improved the stability of the polymer to degradation by ultraviolet light [209]. The ferrocene derivatives [11.3; R = H, Et, Ac, SiMe<sub>3</sub>, CH(OH)Me, C(NO<sub>2</sub>)Me and 11.4] were evaluated as antioxidants for isoprene rubbers. The derivatives were of low volatility, good compatibility with the rubber and high electrode potential and were efficient stabilizers [210].

Dibutylferrocene and an organic nitrile were added to a nematic or cholesteric liquid crystal composition to give an increase in service life and dynamic scattering, an improvement in operating characteristics and a decrease in threshold voltage [211]. Ferrocene derivatives inhibited the autoxidation of cumene in acidic solvents, no effect was observed in neutral solvents. In the corresponding oxidation of ferrocene, oxygen uptake decreased in the following order of substituents:

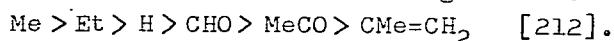

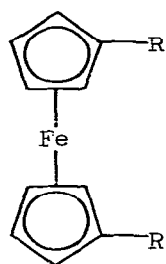

11.3

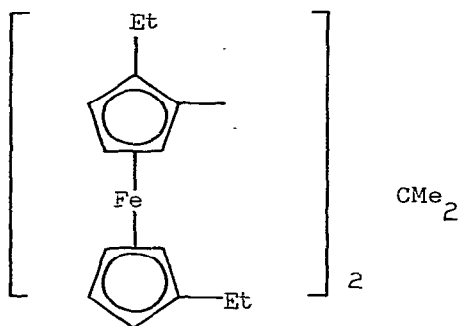

11.4

The behaviour of ferrocene mixed with a siloxane oligomer and 8-hydroxyquinoline as a voltage stabilizer in cross-linked polyethylene insulation was investigated. The mixture containing ferrocene improved the dielectric strength of both cross-linked polyethylene and polyethylene [213].

Poly(diethylene glycol maleates) that had been modified with ferrocene or 1,1'-dialkylferrocenes were crosslinked by styrene in the presence of dibenzylperoxide as initiator. The kinetics of the crosslinking reaction were investigated and the propagation rate constants and the activation energies were determined [214]. Vacuum pyrolysis of an equimolar mixture of triisobutylaluminium and ferrocene led to the deposition of aluminium films on silicon or metals. The presence of ferrocene reduced the growth of aluminium whiskers and etching of the aluminium film [215].

### (iii) Ferrocene in analysis

A reversible redox system such as the ferrocene/ferricinium ion couple has been used for the continuous determination of fatty acids in flotation agents [216]. The amperometric titration of thallium (III) with ferrocene has been examined in aqueous-organic media. Efficient reduction of thallium (III) to thallium (I) was achieved in acetic acid which was 0.5 - 4.5 M in sulphuric acid. Interference by metals and acids was investigated [217]. The methods for the determination of molybdenum using ferrocene have been discussed [218]. The use of ferrocene in the potentiometric determination of iron in alloys has been investigated [219].

The oxidation of ferrocene to the ferricinium ion has been used as the basis of an analytical method for the determination of iron (III), molybdenum (VI) and rhenium (VII). Ferrocene was oxidized in an aqueous-organic medium and the ferricinium ion determined spectrophotometrically. Alternatively molybdenum and rhenium were determined by atomic absorption of the ferricinium ion after removal of the excess ferrocene by solvent extraction with chloroform or dichloroethane [220]. The reduction of silver (I) by ferrocene in aqueous-organic media was studied and the use of this reaction for the amperometric determination of silver was investigated. The effect of solvent on the rate of the reaction was investigated and the optimum conditions for the amperometric determination were established [221]. The characteristics of a carbon paste electrode containing an insoluble electroactive compound, such as ferrocene, and an electrolyte binder have been evaluated using a chronoamperometric procedure. It was demonstrated that the charge transfer reaction occurred between the electrode and the dissolved species [222].

The ferrocene-ferricinium redox couple has been used as a reference for the study of proton medium effects in methanol-water, propylene glycol-water and methanol-propylene glycol mixtures. Perchloric acid and *p*-toluenesulphonic acid were used as supporting electrolytes for the polarographic measurements. The mixtures were found to be more basic than water by this method [223]. Proportional counters for the detection of solar neutrinos which operated at high temperatures required volatile compounds appropriate to the nuclear reaction used. Thus for the reaction  $^{55}\text{Mn}(\nu, e^-)^{55}\text{Fe}$  the most suitable compound was ferrocene [224].

#### (iv) Combustion control

The addition of ferrocene (0.1%) to polycarbonate resins improved their flame retardant properties [225]. The mechanism by which ferrocene suppresses smoke production in the combustion of poly(vinyl chloride) has been investigated by thermal analysis and gas chromatography. At temperatures above 500<sup>o</sup> ferrocene was oxidized to  $\alpha\text{-Fe}_2\text{O}_3$  by hydrogen chloride formed from the burning polymer. The iron oxide was an active smoke suppressant and caused the proportion of low molecular weight volatile products to be enhanced at the expense of benzene. A linear correlation was obtained between the amount of benzene formed and the smoke

evolved in combustion. At temperatures below  $500^{\circ}$  ferrocene caused smoke formation to be increased [226].

Propellants which contained ammonium perchlorate (68%), aluminium (10%) and carboranyldiferrocenylmethyl perchlorate (14%) exhibited ultra high burning rates by comparison with conventional perchlorate propellants [227]. The burning rate of solid propellants containing polybutadiene, finely divided aluminium and ammonium perchlorate were improved by the addition of 2-ferrocenyltetrahydrofuran [228]. The addition of ferrocene to a model propellant mixture containing ammonium perchlorate and styrene did not significantly affect the burning rate [229]. Enhanced combustion rates for composite propellants based on aluminium perchlorate and powdered aluminium were obtained by the incorporation of 1-2% of a ferrocene derivative which acts as a catalyst and a plasticizer. Butylferrocene, amylferrocene and 2-methoxyethyl- $\beta$ -ferrocenoyl propionate were used [230].

The effect of ferrocene as a fuel additive in gas turbine engines was evaluated. Low concentrations of ferrocene (0.025%) reduced the total particulate emissions by 64% when the engine was operated at high power [231].

#### (v) Biochemical and biological applications

The reaction of ferrocene with 3-chloropropionyl chloride gave 3-chloropropionylferrocene which on treatment with cyclohexanethiol gave the ferrocene derivative (11.5). This latter compound (11.5) was useful for the treatment of iron deficiency anemia [232]. Sodium  $\alpha$ -carboxybenzoylferrocene (11.6) was

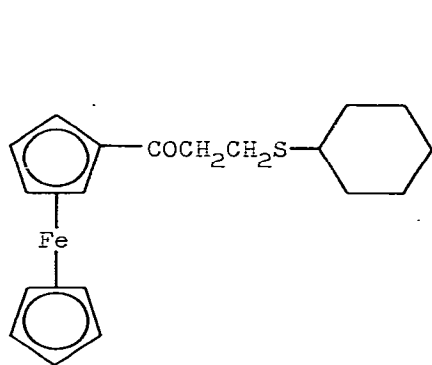

11.5

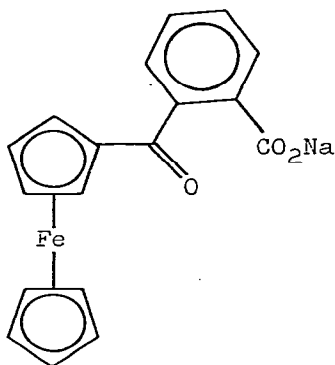

11.6

found to be useful for treating parodontosis in human patients [233]. Ferrocenylpenicillins show excellent antibiotic activity and good resistance to  $\beta$ -lactamase. The compounds were synthesised by condensation of a ferrocenoyl chloride with 6-amino-penicillanic acid. Thus ferrocenylacetyl chloride was treated with the penicillanic acid and triethylamine in methylenedichloride followed by  $\text{BuCHEtCO}_2\text{Na}$  to give the penicillin (11.7) [234].

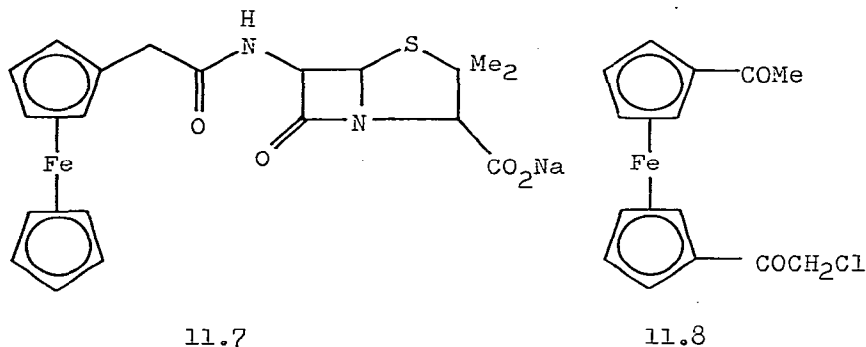

Ferrocenecarboxylic acid labelled with  $^{59}\text{Fe}$  was administered to mice and the distribution and excretion of the compound determined. A very high kidney to muscle ratio was found, ca. 1000 and the metallocene was degraded to give free iron in the urine. The compound was eliminated much faster than  $^{59}\text{Fe}$  labelled iron (III) chloride, ca. 90 times [235]. Thirtynine ferrocene derivatives have been evaluated as microbiological agents. Halogenoacylferrocenes such as 1-acetyl-1'-chloroacetylferrocene (11.8) and 3-chloropropenoylferrocene were most active and functioned as bactericidal agents at high concentrations while showing bacteriostatic effects at low concentrations. The relationship between chemical structure and microbiological activity was considered [236].

Ferrocene derivatives have been claimed as iron fertilizers when mixed with extenders or surface active agents. Monosubstituted ferrocenes such as carboxylate salts, esters, acylferrocenes and ferrocenylimines were used as well as diacylferrocenes (11.9; R = Me, Et, Pr, Bu, C<sub>5</sub>H<sub>9</sub>, C<sub>6</sub>H<sub>11</sub>). These compounds were also used to treat iron deficiency in plants [237, 238]. The ferrocenylmethylthiol derivative (11.10) was

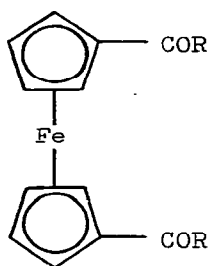

11.9

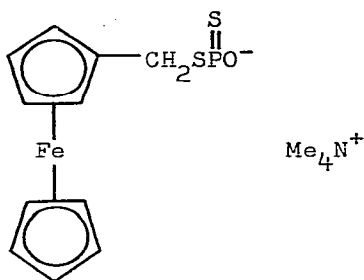

11.10

formed by treatment of the methiodide of (dimethylamino)methylferrocene with the salt  $\text{NaSP(S)(OMe)}_2$ . The product (11.10) was claimed as a convenient source of iron for plants. Several related compounds were also described [239].

## REFERENCES

- 1 Gmelin Handbook of Inorganic Chemistry, Supplementary Work, Vol. 41: Organoiron Compounds, Pt. A: Ferrocene, Sect. 6: Binuclear and Multinuclear Ferrocenes, 8th Ed., Springer-Verlag, Berlin, 1977.
- 2 S. Toma, Chem. Listy, 71 (1977) 478.
- 3 T.S. Abram and W.E. Watts, Organometal. Chem., 5 (1976) 352.
- 4 E.M. Shustorovich, Koord. Khim., 2 (1976) 1142.
- 5 K. Schloegl and H. Falk, Method. Chim., 8 (1976) 469.
- 6 E.I. Edwards, R. Epton, G. Marr, G.K. Rogers and K.J. Thompson, Spec. Publ. Chem. Soc. (Recent Adv. Chem.  $\beta$ -Lactam Antibiot), (1977) 28.
- 7 J. Klikorka and I. Pavlik, Sb. Ved. Pr., Vys. Sk. Chemicko-technol., Pardubice, 34 (1975) 27; Chem. Abstr., 86 (1977) 155720.
- 8 H. Werner, Angew. Chem., 89 (1977) 1.
- 9 J.R. Wasson and H.J. Stoklosa, Annu. Rep. Inorg. Gen. Synth. for 1973, 2 (1974) 196.
- 10 E. Skrzypczak-Jankun and Z. Kaluski, Bull. Acad. Pol. Sci., Ser. Sci. Chim., 24 (1976) 719.
- 11 W.F. Paton, E.R. Corey, J.Y. Corey, M.D. Glick and K. Mislow, Acta Crystallogr., Sect. B, B33 (1977) 268.

- 12 G.M. Brown and L.H. Hall, *Acta Crystallogr., Sect. B*, B33 (1977) 876.
- 13 N.J. Mammano, A. Zalkin, A. Landers and A.L. Rheingold, *Inorg. Chem.*, 16 (1977) 297.
- 14 K. Yasufuku, K. Aoki and H. Yamazaki, *Inorg. Chem.*, 16 (1977) 624.
- 15 T.N. Sal'nikova, V.G. Andrianov and Yu. T. Struchkov, *Koord. Khim.*, 3 (1977) 768.
- 16 Z. Kaluski, A.I. Gusiev and Yu. T. Struchkov, *Bull. Akad. Pol. Sci., Ser. Sci. Chim.*, 24 (1976) 631.
- 17 A. Trautwein, R. Reschke, I. Dezsi and F.E. Harris, *J. Phys. (Paris), Colloq.*, (1976) 463.
- 18 L. Dixit, I.D. Singh and S.K. Kapoor, *Acta Cienc. Indica*, 2 (1976) 192; *Chem. Abstr.*, 86 (1977) 71656.
- 19 L.S. Mayants and G.B. Shaltuper, *Zh. Strukt. Khim.*, 17 (1976) 588.
- 20 A. Ratajczak and H. Zmuda, *Bull. Acad. Pol. Sci., Ser. Sci. Chim.*, 25 (1977) 35.
- 21 V. Ropic, K. Schloegl and B. Steinitz, *Monatsh. Chem.*, 108 (1977) 767.
- 22 A. Gieren, E. Dederer, G. George, D. Marquarding and I. Ugi, *Tetrahedron Lett.*, (1977) 1503.
- 23 A. Ratajczak and B. Misterkiewicz, *Chem. Ind. (London)* (1976) 902.
- 24 W.R. Cullen and E.-S. Yeh, *J. Organometal. Chem.*, 139 (1977) C13.
- 25 M. Zembayashi, K. Tamao, T. Hayashi, T. Mise and M. Kumada, *Tetrahedron Lett.*, (1977) 1799.
- 26 E.E. Roman and D. Astruc, *Nouv. J. Chim.*, 1 (1977) 183.
- 27 S. Toma, A. Maholanyiova and E. Solcaniova, *Collect. Czech. Chem. Commun.*, 42 (1977) 1013.
- 28 K.H. Lieser and C. Marcopoulos, *Radiochim. Acta*, 22 (1975) 111.
- 29 I. Motoyama, M. Shonojima, S. Iijima and H. Sano, *Chem. Lett.*, (1976) 1257.
- 30 R.C. Hill and P.G. Debrunner, *J. Phys. (Paris) Colloq.*, (1976) 41.
- 31 S.L. Ruby, B.J. Zabransky and F.A. Flinn, *J. Phys. (Paris), Colloq.*, (1976) 745.
- 32 R.E. Detjen and D.L. Uhrich, *Mössbauer Eff. Methodol.*, 9 (1974) 113; *Chem. Abstr.*, 36 (1977) 149043.
- 33 V.O. Aimiwu, *Diss. Abstr. Int. B*, 37 (1977) 2351.

- 34 J.M. Wilson, R. Harden and J. Phillips, *Mol. Cryst. Liq. Cryst.*, 34 (1977) 237.
- 35 V.G. Bhide, M.C. Kandpal and S. Chandra, *Solid State Commun.*, 23 (1977) 459.
- 36 P.H. Hemberger and R.C. Dunbar, *Inorg. Chem.*, 16 (1977) 1246.
- 37 E.P. Fesenko and L.V. Iogansen, *Izv. Vyssh. Uchebn. Zaved., Fiz.*, 20 (1977) 158; *Chem. Abstr.*, 87 (1977) 83998.
- 38 V. Cerny, I. Pavlik and E. Kustkova-Maxova, *Collect. Czech. Chem. Commun.*, 41 (1976) 3232.
- 39 V.T. Aleksanyan, L.V. Haley, J.A. Koningstein and T. Parameswaran, *J. Chem. Phys.*, 66 (1977) 3835.
- 40 J.J. Ritsko, P. Nielsen and J.S. Miller, *J. Chem. Phys.*, 67 (1977) 687.
- 41 M.F. Froix (Xerox Corp.), US Pat. 4025541, 1977 May 24; *Chem. Abstr.*, 87 (1977) 135955.
- 42 V.T. Aleksanyan and B.V. Lokshin, *J. Organometal. Chem.*, 131 (1977) 113.
- 43 K. Yokoyama, S. Kobinata and S. Maeda, *Bull. Chem. Soc. Jpn.*, 49 (1976) 2190.
- 44 I.A. Alekseeva, G.N. Yashchenko, T.A. Sinitsyna and L.A. Petrov, *Zh. Obshch. Khim.*, 47 (1977) 1874.
- 45 J.A. Koningstein, L.V. Haley and V.T. Aleksanyan, *Proc. Int. Conf. Raman Spectrosc.*, 5th, (1976) 638.
- 46 D.W. Nielson, *Diss. Abstr. Int. B*, 37 (1977) 3442.
- 47 A.J. Campbell, C.A. Fyfe, D. Harold-Smith and K.R. Jeffrey, *Mol. Cryst. Liq. Cryst.*, 36 (1976) 1.
- 48 M.L. Martin, F. Mabon, B. Gautheron and P. Dodey, *J. Organometal. Chem.*, 124 (1977) 175.
- 49 A.N. Nesmeyanov, E.V. Leonova, E.I. Fedin, N.S. Kochetkova, P.V. Petrovskii and A.I. Lutsenko, *Dokl. Akad. Nauk SSSR*, 237 (1977) 143.
- 50 F.H. Koehler, *Z. Naturforsch., B: Anorg. Chem., Org. Chem.*, 31B (1976) 1151.
- 51 D. Astruc, P. Batail and M.L. Martin, *J. Organometal. Chem.*, 133 (1977) 77.
- 52 R.B. Materikova, V.N. Babin, I.R. Lyatifov, T. Kh. Kurbanov, E.I. Fedin, P.V. Petrovskii and A.I. Lutsenko, *J. Organometal. Chem.*, 142 (1977) 81.
- 53 A.A. Koridze, P.V. Petrovskii, A.I. Mokhov and A.I. Lutsenko, *J. Organometal. Chem.*, 136 (1977) 57.
- 54 A. Kumar and R.R. Ernst, *J. Magn. Reson.*, 24 (1976) 425.
- 55 T.E. Bitterwolf, *Diss. Abstr. Int. B*, 38 (1977) 1703.



- 56 T.E. Bitterwolf and A.C. Ling, *J. Organometal. Chem.*, 141 (1977) 355.
- 57 A. Ratajczak, B. Czech, B. Misterkiewicz, A. Pioko and H. Zyzik, *Bull. Acad. Pol. Sci., Ser. Sci. Chim.*, 24 (1976) 775.
- 58 E.S. Yang, *Diss. Abstr. Int. B*, 37 (1977) 3952.
- 59 M. Hisatome and K. Yamakawa, *J. Organometal. Chem.*, 133 (1977) C9.
- 60 V.G. Guslev, K.K. Kovalenko, A.I. Lesnikovich and V.V. Sviridov, *Fiz. Goreniya Vzyva*, 12 (1976) 441.
- 61 M.M. Sabbatini and E. Cesarotti, *Inorg. Chim. Acta*, 24 (1977) L9.
- 62 C. Pommier and C. Azokpota, *Journ. Calorimetric Anal. Therm.*, [C.R.] 3 (1976) 8.
- 63 R. Freymann, G. Capderroque and M. Selim, *Mol. Spectrosc. Dense Phases, Proc. Eur. Congr. Mol. Spectrosc.*, 12th (1975) 245, Edited by M. Grossmann, S.G. Elkomoss and J. Ringeissen, Elsevier, Amsterdam.
- 64 D.T. Haworth and T. Liu, *J. Chem. Educ.*, 53 (1976) 730.
- 65 D.T. Haworth and T. Liu, *J. Chromatogr. Sci.*, 14 (1976) 519.
- 66 H. Volz and H. Kowarsch, *J. Organometal. Chem.*, 136 (1977) C27.
- 67 R.S. Threlkel and J.E. Bercaw, *J. Organometal. Chem.*, 136 (1977) 1.
- 68 H. Watanabe, K. Ito, F. Nakanishi, T. Akiyama and A. Sugimori, *Bull. Chem. Soc. Jpn.*, 50 (1977) 1349.
- 69 V.I. Boer and A.V. Dombrovskii, *Zh. Obshch. Khim.*, 47 (1977) 727.
- 70 W. Siebert, W. Ruf, K.-J. Schaper and T. Renk, *J. Organometal. Chem.*, 128 (1977) 219.
- 71 W. Ruf, T. Renk and W. Siebert, *Z. Naturforsch., B: Anorg. Chem., Org. Chem.*, 31B (1976) 1028.
- 72 S. Toma, A. Maholanyiova and E. Solcaniova, *Acta Fac. Rerum Nat. Univ. Comenianae, Chim.*, 24 (1976) 53; *Chem. Abstr.*, 87 (1977) 135788.
- 73 T.P. Visnyakova, I.D. Vlasova, T.A. Sokolinskaya, V.I. Gulimov, Ya. Sh. Sokolovskii, N.A. Pankova and N.A. Kir'yanov, *Zh. Obshch. Khim.*, 46 (1976) 2730.
- 74 P.C. Reeves, *Org. Synth.*, 56 (1977) 28.
- 75 R.G. Sutherland, W.J. Pannekoek and C.C. Lee, *J. Organometal. Chem.*, 129 (1977) C1.
- 76 S.V. Mitrokhin, M.G. Felin and K.N. Semenenko, *Vestn. Mosk. Univ., Ser. 2: Khim.*, 18 (1977) 340; *Chem. Abstr.*, 88 (1978) 15335.

- 77 A.I. Busev, V.T. Solomatin and L.I. Kharlamova, Nov., Polyarogr., Tezisy Dolk. Vses. Soveshch. Polyarogr., 6th, (1975) 121; Chem. Abstr., 86 (1977) 25504.
- 78 A. Sh. Cherdabaev and D. Ya. Tsvankin, Vysokomol. Soedin., Ser. A, 19 (1977) 1237.
- 79 S.L. Ruby, B.J. Zabransky and P.A. Flinn, Report 1976, CONF-760938-3; Chem. Abstr., 87 (1977) 46311.
- 80 M. Lamache and D. Bauer, C.R. Hebd., Seances Acad. Sci., Ser. C, 284 (1977) 171.
- 81 V.I. Ignatov and V.T. Solomatin, Zh. Anal. Khim., 32 (1977) 56.
- 82 A.G. Landers, M.W. Lynch, S.B. Raaberg, A.L. Rheingold and N.J. Mammano, US NTIS, AD Rep., 1976, AD-A028830; Chem. Abstr., 86 (1977) 155770; A.G. Landers, M.W. Lynch, S.B. Raaberg, A.L. Rheingold, J.E. Lewis, N.J. Mammano and A. Zalkin, J. Chem. Soc., Chem. Commun., (1976) 931.
- 83 C. LeVanda, K. Bechgaard, D.O. Cowan and M.D. Rausch, J. Amer. Chem. Soc., 99 (1977) 2964.
- 84 R.G. Wollmann and D.N. Hendrickson, Inorg. Chem., 16 (1977) 3079.
- 85 M.A. Wassef, A. El Fitouh and H. Sofaa, Commun. Fac. Sci. Univ. Ankara, Ser. B, 22B (1975) 29; Chem. Abstr., 87 (1977) 38684.
- 86 R. Epton, M.E. Hobson and G. Marr, J. Organometal. Chem., 134 (1977) C23.
- 87 N.V. Zakurin, L.I. Denisovich and S.P. Gubin, J. Organometal. Chem., 129 (1977) 203.
- 88 P.N. Gaponik, A.I. Lesnikovich and Yu. G. Orlik, Zh. Neorg. Khim., 22 (1976) 376.
- 89 W.M. Horspool, R.G. Sutherland and B.J. Thomson, J. Chem. Soc., Perkin Trans., 1 (1977) 1418.
- 90 A.W.C. Lin, P. Yeh, A.M. Yacynych and T. Kuwana, J. Electroanal. Chem. Interfacial Electrochem., 84 (1977) 411.
- 91 A. Ratajczak and B. Misterkiewicz, Roczn. Chem., 51 (1977) 399.
- 92 T.S. Abram and W.E. Watts, J. Chem. Soc., Perkin Trans. 1, (1977) 1522.
- 93 T.S. Abram and W.E. Watts, J. Chem. Soc. Perkin Trans. 1, (1977) 1527.
- 94 T.S. Abram and W.E. Watts, J. Chem. Soc., Perkin Trans. 1, (1977) 1532.
- 95 T.S. Abram, T.D. Turbitt and W.E. Watts, J. Chem. Soc., Perkin Trans. 1, (1977) 1536.

- 96 R.G. Kinnley, W. Lawrie and W.E. Watts, *J. Chem. Soc., Perkin Trans. 1*, (1977) 1542.
- 97 C.A. Bunton and W.E. Watts, *Tetrahedron Lett.*, (1977) 2049.
- 98 C.A. Bunton, N. Carrasco and W.E. Watts, *J. Organometal. Chem.*, 131 (1977) C21.
- 99 M. Cais, P. Ashkenazi, S. Dani and J. Gottlieb, *J. Organometal. Chem.*, 124 (1977) 49.
- 100 R.L. Krieger, *Diss. Abstr. Int. B*, 38 (1977) 1719.
- 101 C.C. Lee, S.-C. Chen, W.J. Pannekoek and R.G. Sutherland, *Can. J. Chem.*, 55 (1977) 1024.
- 102 A.A. Koridze, P.V. Petrovski, S.P. Gubin, V.I. Sokolov and A.L. Mokhov, *J. Organometal. Chem.*, 136 (1977) 65.
- 103 T. Akiyama, T. Kitamura, T. Kato, H. Watanabe, T. Serizawa and A. Sugimori, *Bull. Chem. Soc. Jpn.*, 50 (1977) 1137.
- 104 A.N. Nesmeyanov, N.S. Kochetkova, R.B. Materikova, I.R. Lyatifov, N.V. Fok, T.V. Burova, B.M. Yavorskii and V.M. Trembovler, *Dokl. Akad. Nauk SSSR*, 236 (1977) 624.
- 105 E. Penigault, A.M. Braun and J. Faure, *C.R. Hebd. Seances Acad. Sci., Ser. C*, 283 (1976) 655.
- 106 E.K. Heaney and S.R. Logan, *Inorg. Chim. Acta*, 22 (1977) L3.
- 107 T. Shiraiwa and H. Imai, *Technol. Rep. Kansai Univ.*, 18 (1977) 83; *Chem. Abstr.*, 88 (1978) 6025.
- 108 E.K. Heaney, S.R. Logan and J.A. Powell, *J. Chem. Soc., Faraday Trans. 1*, 73 (1977) 699.
- 109 E.K. Heaney and S.R. Logan, *J. Chem. Soc., Perkin Trans. 2*, (1977) 1353.
- 110 H. Goerner and D. Schulte-Frohlinde, *Ber. Bunsenges, Phys. Chem.*, 81 (1977) 713.
- 111 W. Achermann, *Diss. Abstr. Int. B*, 37 (1977) 5076.
- 112 A.N. Nesmeyanov, Yu. T. Struchkov, N.N. Sedova, V.G. Andrianov, Yu. V. Volgin and V.A. Sazonova, *J. Organometal. Chem.*, 157 (1977) 217.
- 113 A.N. Nesmeyanov, V.A. Sazonova, N.N. Sedova, E.N. Stakheeva, *Izv. Akad. Nauk SSSR Ser. Khim.*, (1977) 2354.
- 114 T.E. Bitterwolf and A.C. Ling, *Synth. React. Inorg. Met.-Org. Chem.*, 7 (1977) 367.
- 115 V.I. Boev and A.V. Dombrovskii, *Zh. Obshch. Khim.*, 47 (1977) 2215.
- 116 A.N. Nesmeyanov, D.N. Kursanov, V.N. Setkina, N.K. Baranetskaya, V.D. Vil'chevskaya, V.I. Losilkina, G.A. Panasyan and A.I. Krylova, *Izv. Akad. Nauk SSSR, Ser. Khim.*, (1977) 2263.

117. F. Mathey, A. Mitschler and R. Weiss, *J. Amer. Chem. Soc.*, 99 (1977) 3537.
- 118 F. Mathey, *J. Organometal. Chem.*, 139 (1977) 77.
- 119 G.A. Razuvaev, G.A. Domrachev, V.V. Sharutin and O.N. Suvorova, *J. Organometal. Chem.*, 141 (1977) 313.
- 120 S.S. Crawford and H.D. Kaesz, *Inorg. Chem.*, 16 (1977) 3193.
- 121 S.S. Crawford, C.B. Knobler and H.D. Kaesz, *Inorg. Chem.*, 16 (1977) 3201.
- 122 K. Yasufuku and H. Yamazaki, *J. Organometal. Chem.*, 127 (1977) 197.
- 123 M. Nonoyama, *Inorg. Nucl. Chem. Lett.*, 12 (1976) 709.
- 124 V.I. Sokolov, L.L. Troitskaya and O.A. Reutov, *J. Organometal. Chem.*, 133 (1977) C28.
- 125 L.L. Troitskaya, V.I. Sokolov and O.A. Reutov, *Dokl. Akad. Nauk SSSR*, 236 (1977) 371.
- 126 A. Kasahara, T. Izumi and M. Maemura, *Bull. Chem. Soc. Jpn.*, 50 (1977) 1878.
- 127 A.N. Nesmeyanov, E.G. Perevalova, V.P. Dyadchenko and K.I. Grandberg, *Izv. Akad. Nauk SSSR, Ser. Khim.*, (1976) 2844.
- 128 O. Traverso, C. Chiorboli, U. Mazzi and G.L. Zucchini, *Gazz. Chim. Ital.*, 107 (1977) 181.
- 129 J.T. Mague and M.O. Nutt, *Inorg. Chem.*, 16 (1977) 1259.
- 130 T. Hayashi, T. Mise and M. Kumada, *Tetrahedron Lett.*, (1976) 4351.
- 131 G.P. Sollott, D.L. Daughdrill and W.R. Peterson, *J. Organometal. Chem.*, 133 (1977) 347.
- 132 A.N. Nesmeyanov, E.G. Perevalova, O.B. Afanasova and K.I. Grandberg, *Izv. Akad. Nauk SSSR, Ser. Khim.*, (1977) 2166.
- 133 R. Weiss and R.N. Grimes, *J. Amer. Chem. Soc.*, 99 (1977) 8087.
- 134 M.B. Freeman, L.G. Sneddon and J.C. Huffman, *J. Amer. Chem. Soc.*, 99 (1977) 5194.
- 135 A.J. Fry, R.L. Krieger, I. Agranat and E. Aharon-Shalom, *Tetrahedron Lett.*, (1976) 4803.
- 136 V.V. Krasnikov, Yu. P. Andreichikov, N.V. Kholodova and G.M. Dorofeenko, *Zh. Org. Khim.*, 13 (1977) 1566.
- 137 T. Niem and M.D. Rausch, *J. Org. Chem.*, 42 (1977) 275.
- 138 V.I. Boev, A.S. Osipenko and A.V. Dombrovskii, *Zh. Obshch. Khim.*, 47 (1977) 1573.
- 139 V.I. Boev, A.S. Osipenko and A.V. Dombrovskii, *Zh. Obshch. Khim.*, 47 (1977) 426.
- 140 E.A. Kalennikov and R.I. Dashevskaya, *Zh. Obshch. Khim.* 47 (1977) 1320.

- 141 M.L. Talbot (Syntex Corp.) US Pat. 3989731, 1976, Nov. 2;  
Chem. Abstr., 86 (1977) 90032.
- 142 A. Kasahara, T. Izumi and M. Maemura, Bull. Chem. Soc. Jpn.,  
50 (1977) 1021.
- 143 L.P. Asatiani and I.M. Gverdtsiteli, Soobshch. Akad. Nauk.  
Gruz. SSR, 85 (1977) 369; Chem. Abstr., 87 (1977) 23455.
- 144 I.R. Askarov, A.G. Makhsumov and E.A. Mirzabaev, Deposited  
Doc. 1973, VINITI, 7434; Chem. Abstr., 86 (1977) 190160.
- 145 A.G. Makhsumov, I.R. Askarov, M. Mamadaliev and T. Mirzakasimov,  
Deposited Doc., 1973, VINITI 6877; Chem. Abstr., 86 (1977)  
190161.
- 146 A.G. Makhsumov and I.R. Askarov, Deposited Doc., 1973, VINITI  
6878; Chem. Abstr., 86 (1977) 190162.
- 147 A.G. Makhsumov, I.R. Askarov, Sh. Inoyatov and A.N. Kryzhenkov,  
Deposited Doc. 1973, VINITI 7433; Chem. Abstr., 86 (1977)  
190164.
- 148 A.G. Makhsumov, I.R. Askarov and M.A. Atakhodzhaeva, Deposited  
Doc., (1973) VINITI 7432; Chem. Abstr., 86 (1977) 171575.
- 149 A.N. Nesmeyanov, G.B. Shul'pin, V.V. Krivykh and M.I.  
Rybinskaya, Dokl. Akad. Nauk SSSR, 232 (1977) 330.
- 150 Y. Shirota, J. Magata, Y. Nakano, T. Nogami and H. Mikawa,  
J. Chem. Soc., Perkin Trans. 1, (1977) 14.
- 151 I.M. Gverdtsiteli and L.P. Asatiani, Tbilisis Universitetis  
Shromebi, Tr. Tbilis Un-ta (1976) 41; From Ref. Zh. Khim.  
(1976) Abstr. No. 24Zh371; Chem. Abstr., 86 (1977) 121492.
- 152 K.M. Hassan, J. Indian Chem. Soc., 53 (1976) 1185.
- 153 G.N. Dorofeenko, V.V. Krasnikov and A.I. Pyshchev, Khim.  
Geterotsikl, Soedin., (1977) 599; Chem. Abstr., 87 (1977)  
85121.
- 154 E.E. Vittal and V.I. Boev, Zh. Org. Khim., 13 (1977) 2059.
- 155 A.V. Dombrovskii and E.E. Vittal, Tezisy Dolk.-Ukr. Resp.  
Konf. Org. Khim., 12th 1973 (Pub. 1974) 69; Chem. Abstr.,  
86 (1977) 121488.
- 156 V.I. Boev and A.V. Dombrovskii, Zh. Obshch. Khim., 47 (1977)  
1892.
- 157 M.I. Kalinkin, G.D. Kolomnikova, V.E. Puzanova, M.M. Gol'din,  
Z.N. Parnes and D.N. Kursanov, Izv. Akad. Nauk SSSR, Ser.  
Khim., (1977) 1852.
- 158 A. Ratajczak and B. Czech, Rocz. Chem., 51 (1977) 1735.
- 159 A. Ratajczak and A. Piorko, Rocz. Chem., 51 (1977) 967.
- 160 P. Etievant, G. Tainturier and B. Gautheron, C.R. Hebd.  
Seances Acad. Sci., Ser. C, 283 (1976) 233.

- 161 E.A. Kalennikov, Zh. Obshch. Khim., 47 (1977) 628.
- 162 A.N. Nesmeyanov, G.B. Shul'pin, M.V. Tolstaya and M.I. Rybinskaya (Institute of Heteroorganic Compounds), USSR Pat. 555114, 1977 Apr. 25; Chem. Abstr., 87 (1977) 135954.
- 163 A.N. Nesmeyanov, G.B. Shul'pin, M.V. Tolstaya and M.I. Rybinskaya (Institute of Heteroorganic Compounds) USSR Pat. 555113, 1977, Apr 25; Chem. Abstr., 87 (1977) 135953.
- 164 M. Le Plouzennec and R. Dabard, J. Organometal. Chem., 133 (1977) 359.
- 165 A.N. Nesmeyanov, M.V. Tolstaya, G.B. Shul'pin and M.I. Rybinskaya, USSR Pat., 539894, 1976, Dec. 25; From Otkrytiya Izobret., From. Obraztsy, Tovarnye Znaki, 53 (1977) 79; Chem. Abstr., 86 (1977) 171603.
- 166 A. Ratajczak, B. Misterkiewicz and B. Czech, Bull. Acad. Pol. Sci., Ser. Sci. Chim., 25 (1977) 27.
- 167 A. Ratajczak and B. Czech, Bull. Akad. Pol. Sci., Ser. Sci. Chim., 25 (1977) 635.
- 168 V.P. Tverdokhlebov, I.V. Tselinskii, B.V. Gidasov and G. Yu. Chikisheva, Zh. Org. Khim., 12 (1976) 2335.
- 169 V.P. Tverdokhlebov, I.V. Tselinskii, B.V. Gidasov and A.I. Shemyakin, Zh. Org. Khim., 12 (1976) 2512.
- 170 G.N. Yashchenko, A.A. Shashmurina, L.A. Petrov and N.I. Latosh, Zh. Obshch. Khim., 46 (1976) 2631.
- 171 M.A. Stepanova, V.P. Tverdokhlebov, R.S. Stepanov, I.V. Tselinskii and B.V. Gidasov, Zh. Org. Khim., 13 (1977) 1364.
- 172 H. Uysal and B. Gautheron, Bull. Soc. Chim. Fr., 3-4 (1977) 263.
- 173 T. Katada, M. Nishida, S. Kato and M. Mizuta, J. Organometal. Chem., 129 (1977) 189.
- 174 J. Malthe and J. Billard, Mol. Cryst. Liq. Cryst., 34 (1976) 117.
- 175 A. Ratajczak, B. Czech and B. Misterkiewicz, Bull. Acad. Pol. Sci., Ser. Sci. Chim., 25 (1977) 541.
- 176 K. Chhor Y Sok, G. Tainturier and B. Gautheron, J. Organometal. Chem., 132 (1977) 173.
- 177 M. Salisova, S. Toma and E. Solcaniova, J. Organometal. Chem., 132 (1977) 419.
- 178 M. Hisatome, N. Watanabe, T. Sakamoto and K. Yamakawa, J. Organometal. Chem., 125 (1977) 79.
- 179 M. Hisatome and K. Yamakawa, Shitsuryo Bunseki, 24 (1976) 283; Chem. Abstr., 87 (1977) 52353.
- 180 M. Hisatome, N. Watanabe and K. Yamakawa, Chem. Lett., (1977) 743.

- 181 A.N. Nesmeyanov, G.B. Shulpin, M.V. Tolstaya and M.I. Rybinskaya, Dokl. Akad. Nauk SSSR, 232 (1977) 1319.
- 182 T.N. Sal'nikova, V.G. Andrianov, M. Yu. Antipin and Yu. T. Struchkov, Koord. Khim., 3 (1977) 939.
- 183 P.V. Roling and M.D. Rausch, J. Organometal. Chem., 141 (1977) 195.
- 184 D.I. Sugarman, Diss. Abstr. Int. B, 37 (1977) 4472.
- 185 A.N. Nesmeyanov, N.N. Sedova, Yu. V. Volgin and V.A. Sazonova, Izv. Acad. Nauk SSSR, Ser. Khim., (1976) 2831.
- 186 Z.F. Saikina, S.L. Sosin and V.V. Kopylov, Vysokomol. Soedin., Ser. B, 18 (1976) 843.
- 187 S. Yajima and M. Omori, Nature (London), 267 (1977) 823.
- 188 M. Omori, K. Nagashima and S. Yajima, Bull. Chem. Soc. Jpn., 50 (1977) 1157.
- 189 A.I. Volozhin, L. Yu. Verkhovodka, A.A. Rozmyslova and Ya. M. Paushkin, Vysokomol. Soedin., Ser. B, 19 (1977) 593.
- 190 V.P. Red'ko, V.K. Skubin, D.F. Kutepov and V.N. Muzykantov, Plast. Massy, (1977) 42.
- 191 A. Gal, M. Cair and D.H. Kohn, J. Polym. Sci., Polym. Chem. Ed., 15 (1977) 461.
- 192 H. Kato and H. Kan (Dainichi Nippon Cables), Japan. Pat. 7791093, 1977, Aug 1; Chem. Abstr., 87 (1977) 185493.
- 193 H. Kato and H. Kan (Dainichi Nippon Cables), Japan. Pat. 7791094, 1977, Aug 1; Chem. Abstr., 87 (1977) 185494.
- 194 H. Kato and H. Kan (Dainichi Nippon Cables), Japan. Pat. 7791095, 1977, Aug 1; Chem. Abstr., 87 (1977) 185495.
- 195 H. Kato, H. Fujita and H. Suga (Dainichi Nippon Cables) Japan. Pat. 77 42294, 1977 Apr 1; Chem. Abstr., 87 (1977) 69375.
- 196 C. Simionescu and I. Mazilu, Rev. Roum. Chim., 22 (1977) 753.
- 197 C.U. Pittman and A. Hirao, J. Polym. Sci., Polym. Chem. Ed., 15 (1977) 1677.
- 198 A.E. Vodopyanova, Yu. P. Losev, Ya. M. Paushkin and R.V. Chibrikova, Dokl. Akad. Nauk SSSR, 21 (1977) 611.
- 199 J.F. Vikesland and F. Wilkinson, J. Chem. Soc., Faraday Trans. 2, 73 (1977) 1082.
- 200 H. Kato (Dainichi Nippon Cables Ltd.) Japan Kokai, 7697797, 1976, Aug. 27; Chem. Abstr., 86 (1977) 32865.
- 201 T.E. Kiovisky and M.M. Wald (Shell Oil Co), US Pat., 4006177, 1977, Feb. 1; Chem. Abstr., 86 (1977) 111638.
- 202 S.P. McManus, H.S. Bruner, H.D. Coble and M. Ortiz, J. Org. Chem., 42 (1977) 1428.

- 203 T. Shiga, K. Tomokumi, H. Kobayashi and M. Yoshino (Asahi Chemical Industry Co., Ltd.), Japan Pat., 76102627, 1976, Sept. 10; Chem. Abstr., 86 (1977) 148808.
- 204 T. Shiga and M. Yoshino (Asahi Chemical Industry Co., Ltd.) Japan Pat. 76 17428, 1976, Feb. 12; Chem. Abstr., 86 (1977) 113726.
- 205 G. Toshinao (Ricoh Co., Ltd.) Japan Pat., 7653818 1976, May 12; Chem. Abstr., 86 (1977) 131099.
- 206 E.A. Kalennikov, Ya. M. Paushkin, L.V. Turkina, S.V. Markevich, A.E. Perever'zev and T.N. Ustimenko, USSR Pat., 533614, 1976, Oct. 30; From Otkrytiya Izobret., Prom. Obraztsy, Tovarnye Znaki, 53 (1976) 67; Chem. Abstr., 86 (1977) 107476.
- 207 E.A. Kalennikov, A.N. Sokolov, V.S. Yuran and Ya. M. Paushkin, Dokl. Akad. Nauk BSSR, 21 (1977) 329.
- 208 E.A. Kalennikov, A.N. Sokolov, S.L. Sosin and V.S. Yuran, USSR Pat., 533615, 1976, Oct. 30; From Otkrytiya, Izobret., Prom. Obraztsy, Tovarnye Znaki, 53 (1976) 66; Chem. Abstr., 86 (1977) 56291.
- 209 E.A. Kalennikov, V.S. Yuran and T.N. Ustimenko, USSR Pat., 530893, 1976, Oct. 5; From Otkrytiya, Izobret., Prom. Obraztsy, Tovarnye Znaki, 53 (1976) 63; Chem. Abstr., 86 (1977) 44406.
- 210 E.A. Kalennikov, T.E. Ognevskaya, T.N. Mitrokhina, R.I. Dashevskaya and Ya. M. Paushkin, Vesti Akad. Nauk BSSR, Ser. Khim., Nauk, (1977) 58; Chem. Abstr., 89 (1977) 7167.
- 211 H.S. Lim (Hughes Aircraft Co.) Ger. Pat. 2656252, 1977 Jul 14; Chem. Abstr., 87 (1977) 93584.
- 212 S. Muto, H. Kochi and Y. Kamiya, Sekiyu Gakkai Shi, 17 (1974) 150; Chem. Abstr., 87 (1977) 133530.
- 213 H. Kato, N. Maekawa, S. Inoue and H. Fujita, Annu. Rep. Conf. Electr. Insul. Dielectr. Phenom., (1974) 229; Chem. Abstr. 86 (1977) 57959.
- 214 V.P. Red'ko, V.K. Skubin, D.F. Kutepov and V.V. Kershak, Vysokomol. Soedin., Ser. B, 19 (1977) 118.
- 215 B.V. Zhuk, V.N. Khamylov, B.A. Nesterov, G.A. Domrachev and N.K. Zaglunonia, Dokl. Akad. Nauk SSSR, 233 (1977) 862.
- 216 V.I. Zlatkin, A.N. Makovskii, A.G. Krasnov, V.G. Krunchak, A.G. Rodichev, E.S. Sorokin and E.G. Krunchak (Leningrad Mining Institute), USSR Pat. 550568, 1977 Mar 15; Chem. Abstr., 87 (1977) 62163.
- 217 V.T. Solomatina and S.P. Rzhavichev, Zh. Anal. Khim., 31 (1976) 2345.



- 218 V.T. Solomatin, T.N. Artemova and L.A. Lapshina, *V sb., i Standartiz Metodov Analiza Khim. Sostava Materialov* (1976) 140; *From Ref. Zh. Khim.*, (1976) Abstr. No 21G145; *Chem. Abstr.*, 86 (1977) 164785.
- 219 V.T. Solomatin, T.N. Artemova and S.P. Rzhavichev, *Novye Metody Ispyt. Metallov*, (1977) 47; *From Ref. Zh. Metall.*, (1977) Abstr. No. 6K13; *Chem. Abstr.*, 88 (1978) 44436.
- 220 V.T. Solomatin, G.V. Kozina and S.P. Rzhavichev, *Org. Reagenty Anal. Khim., Tezisy Dokl. Vses. Konf.*, 4th, 2 (1976) 27; *Chem. Abstr.*, 87 (1977) 177049.
- 221 V.T. Solomatin, V.I. Ignatov and S.P. Rzhavichev, *Zh. Anal. Khim.*, 32 (1977) 948.
- 222 L. Lamache and D. Bauer, *J. Electroanal. Chem. Interfacial Electrochem.*, 79 (1977) 359.
- 223 C. Kalidas, P. Sivaprasad and U.V.Venkatram, *Z. Naturforsch.*, A, 32A (1977) 791.
- 224 I.R. Barabanov, V.N. Gavrin, Yu. I. Zakharov and G.T. Zatsepin, *Neutrino '75 Proc., IUPAC Conf.*, 2 (1975) 395; *Chem. Abstr.*, 87 (1977) 13234.
- 225 A.L. Baron and P. Sivaramakrishnan (Mobay Chemical Co.) *US Pat.*, 4017457, 1975, Oct 6; *Chem. Abstr.*, 86 (1977) 172562.
- 226 L. Lecomte, M. Bert, A. Michel and A. Guyot, *J. Macromol. Sci., Chem.*, A 11 (1977) 1467.
- 227 D.C. Sayles (US Dept. of the Army), *US Pat.* 4026912, 1977 May 31; *Chem. Abstr.*, 87 (1977) 87247.
- 228 O.E. Ayers and D.C. Van Landuyt (US Dept. of the Army) *US Pat.*, 3951703, 1976, Apr. 20; *Chem. Abstr.*, 86 (1977) 45340.
- 229 A.V. Boldyreva, R.P. Mitrofanova, V.V. Boldyrev and R.K. Tukhtaev, *Fiz. Goreniya Vzryva*, 12 (1976) 506.
- 230 W.F. Arendale (Thiokol Corp.), *US Pat.* 4023994, 1977. May 17; *Chem. Abstr.*, 87 (1977) 203844.
- 231 A.F. Klarman and J.E. Horling, *Int. Conf. Environ. Sensing Assess. [Proc.]* 2 (1975) 41; *Chem. Abstr.*, 86 (1977) 77842.
- 232 Anon (Fisons Ltd.) *Neth. Pat. Appl.* 7600250, 1976 Jul. 19; *Brit. Pat. Appl.* 75/1682, 1975, Jan 15; *Chem. Abstr.*, 86 (1977) 111186.
- 233 A.N. Nesmeyanov, L.G. Bogomolova, N.S. Kochetkova, V.D. Vilchevskaya, N.P. Palitsyn, Yu. Yu. Gorelikova, I.G. Andrianova, O.P. Belozeroва and V.K. Syundyukova, *US Pat.* 3996377, 1976, Dec. 7; *Chem. Abstr.*, 86 (1977) 78687.

- 234 E.I. Edwards, R. Epton and G. Marr, Brit. Pat. 1470210, 1977, Apr. 14; Chem. Abstr., 87 (1977) 135313.
- 235 M. Wenzel, E. Nipper and W. Klose, J. Nucl. Med., 18 (1977) 367.
- 236 S. Toma, P. Foltinova and E. Zikova, Acta Fac. Rerum Nat. Univ. Comenianae, Chim., 25 (1977) 9.
- 237 V. Mues and J. Niggemann (Bayer A.-G.), Ger. Pat. 2543999, (1977) Apr. 7; Chem. Abstr., 87 (1977) 67314.
- 238 V. Mues and J. Niggemann (Bayer A.-G.), Ger. Pat. 2553786, 1977 Jun. 2; Chem. Abstr., 87 (1977) 67316.
- 239 V. Mues and J. Niggemann, (Bayer A.-G.) Ger. Pat. 2553787, 1977, Jun. 02; Chem. Abstr., 87 (1977) 168204.