

ELECTROCHEMICAL FORMATION OF STABLE FERROCENE ANION AND THE FORMAL RATE CONSTANT OF THE FERROCENE^{0/-} ELECTRODE

NAOYUKI ITO, TETSUO SAJI * and SHIGERU AOYAGUI

Department of Chemical Engineering, Tokyo Institute of Technology, Ohokayama, Meguro-ku, Tokyo 152 (Japan)

(Received November 4th, 1982)

Summary

A reversible cyclic voltammogram for the one-electron reduction of ferrocene in 1,2-dimethoxyethane is recorded under experimental conditions that enable the ferrocene anion to exist for a few minutes. The formal rate constant of the ferrocene^{0/-} electrode, determined by cyclic voltammetry at -45°C , ca. $10^{-3} \text{ cm s}^{-1}$, is in striking contrast with that of ferrocene⁺⁰, $> 10^{-1} \text{ cm s}^{-1}$. The distortion of the ferrocene molecule caused by reduction may be a reason for this difference in electron-transfer rate.

Introduction

Many synthetic and physicochemical studies of ferrocene (FC) have been made since its discovery [1]. It is known that FC can be oxidized to ferrocenium ion (FC⁺) electrochemically as well as chemically [2]. On the reduction of FC, however, only a few results have been reported. Important ones are as follows: lithium-metal reduction of FC in ethylamine at room temperature results in cleavage of the FC molecule into metallic iron and cyclopentadiene molecules [3]; the formation of ferrocene anion (FC⁻) is suggested by the reversible one-electron reduction step on a cyclic voltammogram of FC in *N,N*-dimethylformamide (DMF) recorded at -30°C with a scan rate (v) of 1 V s^{-1} [4]; the formation of FC⁻ by the γ -ray irradiation of FC in frozen matrices is confirmed spectroscopically [5].

This paper deals with voltammetry of FC in 1,2-dimethoxyethane (DMeE), in order to gain information on the stability of FC⁻ and the charge-transfer rate of the FC^{0/-} electrode.

Experimental

Ferrocene supplied by Tokyo Chemical Industries was used without further purification. The base solution, 0.2 *M* tetra-*n*-butylammonium perchlorate (TBAP)

* To whom correspondence should be addressed.

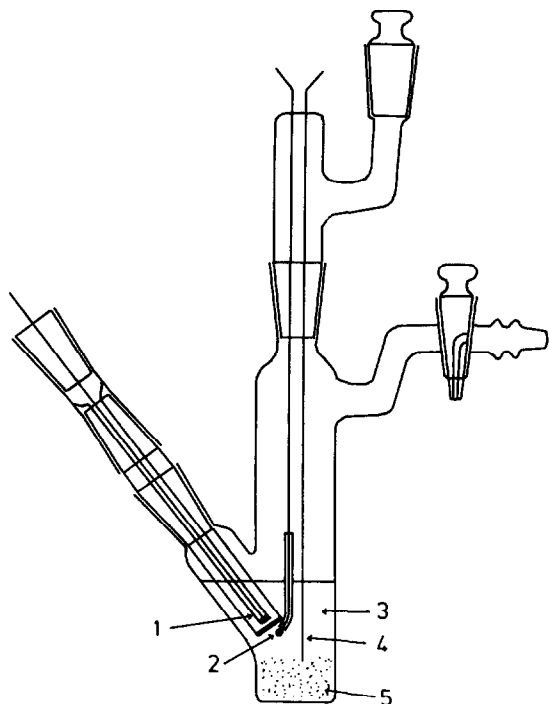

Fig. 1. Electrolysis Cell: (1) Ag/AgNO₃(sat.); (2) Pt sphere; (3) solution; (4) Pt wire; (5) neutral alumina.

in DMeE, was prepared in a similar way as described previously [6]. Figure 1 shows the electrolysis cell used, in which a platinum sphere, a platinum wire and an Ag/AgNO₃(sat.) serve as the working, counter and reference electrodes respectively. The test solution was kept in contact with neutral alumina during measurement [7]. The ohmic potential loss between the reference and the working electrodes was compensated with the usual positive-feedback technique.

Results and discussion

Figure 2 shows a cyclic voltammogram of 0.5 mM FC at -45°C , recorded with $\nu = 0.02 \text{ V s}^{-1}$. It exhibits one reduction step at -3.576 V vs. Ag/AgNO₃(sat.), besides the oxidation step of FC⁺⁰ at -0.130 V , where potentials are indicated in terms of the potential at the midpoint between the cathodic peak potential (E_{pc}) and the anodic one (E_{pa}). This reduction step, being nearly equal in peak height to the oxidation step, may be assigned to FC^{0/-}.

Since the anodic current peak of the FC^{0/-} step can be observed even with $\nu = 0.01 \text{ V s}^{-1}$, the lifetime of FC⁻ in DMeE at -45°C may be longer than a few minutes. At $\nu = 0.2 \text{ V s}^{-1}$, this peak was observable at -10°C , but it was masked by the ultimate current rise above 0°C , similarly to the result of Mugnier et al. that the FC^{0/-} step in DMF was reversible at -30°C and 1 V s^{-1} , but irreversible at 0°C irrespective of scan rates [4].

Table 1 lists peak separations ($\Delta E_p = E_{pa} - E_{pc}$) at various scan rates. The ΔE_p values for FC⁺⁰ do not depend on ν , and are a little greater than the theoretical

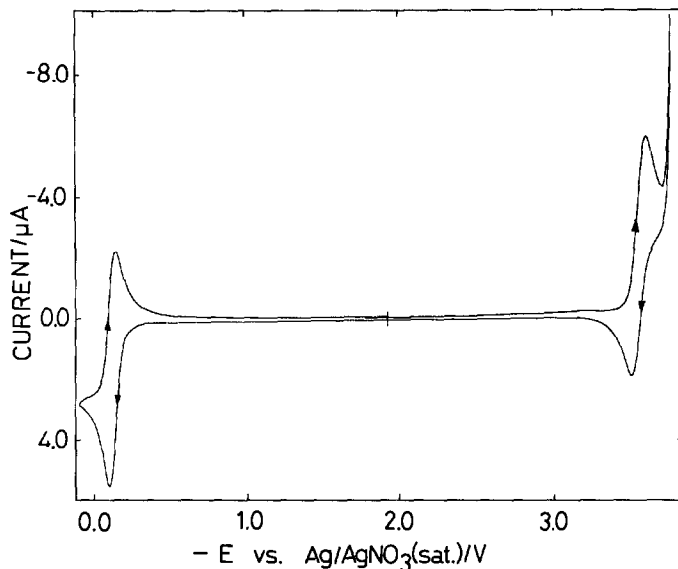

Fig. 2. Cyclic voltammogram of 0.5 mM ferrocene in 0.2 M TBAP/DMeE at -45°C . Scan rate 0.02 V s^{-1} .

value for the nernstian one-electron process, 45 mV. This discrepancy may be due to the residual ohmic drop after compensation, and not to the slowness of the charge-transfer process. Since the electrode reaction of $\text{FC}^{+/0}$ is reversible at $v = 0.28\text{ V s}^{-1}$, the formal rate constant (k^0) should be greater than 10^{-2} cm s^{-1} at -45°C [8]. This is in accord with the expectation that it should be of the order of 10^{-1} cm s^{-1} , which is based on our previous findings that the k^0 value of this electrode in methanol is 0.7 cm s^{-1} at room temperature [9] and that the k^0 value of $[\text{Fe}(2,2'\text{-bipyridine})_3]^{2+/+}$ is 0.35 cm s^{-1} at 40°C and 0.1 cm s^{-1} at -20°C [10]. In contrast, the increase in the ΔE_p of $\text{FC}^{0/-}$ with increasing v should be attributed to the slowness of the electrode reaction.

TABLE I

THE PEAK SEPARATIONS OF CYCLIC VOLTAMMOGRAMS FOR $\text{FC}^{+/0}$ ($\Delta E_p^{+/0}$) and $\text{FC}^{0/-}$ ($\Delta E_p^{0/-}$) IN 0.2 M TBAP/DMeE AT -45°C , AND THE FORMAL RATE CONSTANTS. FOR $\text{FC}^{0/-}$ (k^0) DETERMINED FROM $\Delta E_p^{0/-}$ AT VARIOUS SCAN RATES (v)

v (V s^{-1})	$\Delta E_p^{+/0}$ (mV)	$\Delta E_p^{0/-}$ (mV)	$10^3 k^0$ (cm s^{-1})
0.02	53	104	1.7
0.04	54	123	1.6
0.06	55	132	1.6
0.08	55	138	1.7
0.10	54	146	1.6
0.15	55	161	1.7
0.20	54	170	1.7
0.25	56	181	1.7
0.28	55	185	1.6

The k^0 value of the $\text{FC}^{0/-}$ electrode was roughly estimated by the method of Nicholson on the basis of the following equation from the working curves of ΔE_p vs. Ψ [8]:

$$\Psi = k^0 (D_0/D_R)^{\alpha/2} / (\pi v D_0 n F / RT)^{1/2} \quad (1)$$

where α is the transfer coefficient, and D_0 and D_R are the diffusion coefficients of the oxidant and the reductant, respectively, and the remaining terms have their usual meanings. In calculating the approximate value of k^0 , it was assumed that $\alpha = 0.5$ and $D_R = D_0$. The D_0 value of FC, $3.5 \times 10^{-6} \text{ cm}^2 \text{ s}^{-1}$, was determined by comparing the peak currents of $\text{FC}^{+/0}$ and $\text{Fe}(\text{CN})_6^{3-/4-}$ with each other, and by using a literature D_0 value of $\text{Fe}(\text{CN})_6^{3-/4-}$ [11]. The k^0 values thus determined are listed in Table 1. The agreement among the k^0 values at different scan rates is excellent; they give an average value of $(1.7 \pm 0.1) \times 10^{-3} \text{ cm s}^{-1}$.

Attention should be called to the great difference between the k^0 values of $\text{FC}^{+/0}$ and $\text{FC}^{0/-}$. It is unlikely that the difference in outer-sphere reorganization energy (λ_0) can account for this, because no appreciable difference in molecular radius should exist among FC^+ , FC and FC^- [12]. Alternatively, there may be two possibilities. One is the effect of ϕ_2 -potential. Unfortunately, we cannot discuss this effect at this stage, since the potential of zero charge and the ϕ_2 -potential of a platinum electrode in DMeE are not known. The other possibility is the inner-sphere reorganization energy (λ_i). The empirical relation between the activation free energy and λ_0/λ_i , which is illustrated in Fig. 2 of ref. 9, shows that the difference between $k^0 = 0.7 \text{ cm s}^{-1}$ and $1.7 \times 10^{-3} \text{ cm s}^{-1}$ can be ascribed to the difference in λ_i , when the difference in λ_0 is negligible. We have the following reasons to believe that the contribution of λ_i to the total activation free energy is important in $\text{FC}^{0/-}$ and not in $\text{FC}^{+/0}$. First, the redox reaction of $\text{FC}^{+/0}$ is very fast both in solution and at the electrode, as seen from the homogeneous rate constant of $5 \times 10^6 \text{ M}^{-1} \text{ s}^{-1}$ [13] and the electrochemical rate constant of $k^0 = 0.7 \text{ cm s}^{-1}$ [9]. In our experience, such rate constants are characteristic of redox systems of aromatic hydrocarbons and inert metal complexes which have small λ_i [14]. Secondly, if both cyclopentadienyl ligands have normal *pentahapto* arrangements, the electron configuration of the Fe atom would exceed the electron number of the Kr atom by one electron.

Consequently, it is likely that FC^- has one bent *tetrahapto*- and one planar *pentahapto*-cyclopentadienyl ligand, which leads to the energetically favourable 18-electron configuration for the Fe atom, a similar situation as encountered in $[\text{W}(\text{O})(\text{C}_2\text{H}_5)_2(\text{CO})_2]$ [15]. Under these circumstances, the λ_i value for $\text{FC}^{0/-}$ would be significant. The same situation has been encountered in the cases of cyclooctatetraene [16] and stilbene [17], where stereochemical effects prevail. Similarly, Holloway et al. [18] have suggested the slipped sandwich structure for the nickelocene anion. However, the wave form of the cyclic voltammogram of nickelocene $^{0/-}$ given by these authors shows that an e.c.e. mechanism, rather than a simple, slow electron transfer, may operate.

References

- 1 Gmelin Handbuch der anorganischen Chemie, Bd. 14, Teil A, Ferrocene 1, Springer, Berlin, 1974.
- 2 C.K. Mann and K.K. Barnes, *Electrochemical Reactions in Nonaqueous Systems*, Marcel Dekker, New York, 1970, Chap. 13.

- 3 D.S. Trifan and L. Nicholas, *J. Amer. Chem. Soc.*, 79 (1957) 2746.
- 4 Y. Mugnier, C. Moise, H. Tirouflet and F. Laviron, *J. Organometal. Chem.*, 186 (1980) C49.
- 5 S. Ikuta, A. Kira, M. Imamura, I. Motoyama and H. Sano, *Bull. Chem. Soc. Jpn.*, 54 (1981) 549.
- 6 T. Saji, T. Yamada and S. Aoyagui, *J. Electroanal. Chem.*, 61 (1975) 147.
- 7 B.S. Jensen and V.D. Parker, *J. Amer. Chem. Soc.*, 97 (1975) 5211.
- 8 R.S. Nicholson, *Anal. Chem.*, 37 (1965) 1351.
- 9 T. Saji, Y. Maruyama and S. Aoyagui, *J. Electroanal. Chem.*, 86 (1978) 219.
- 10 M. Miyagawa, Y. Sato, Y. Ohsawa, K. Suga and S. Aoyagui, unpublished data.
- 11 D.H. Angell and T. Dickinson, *J. Electroanal. Chem.*, 35 (1972) 55.
- 12 D.R. Stranks, *Discuss. Faraday Soc.*, 29 (1960) 73.
- 13 E.S. Yang, M. Chan and A.C. Wahl, *J. Phys. Chem.*, 79 (1975) 2049.
- 14 J.M. Hale in N.S. Hush (Ed.), *Reactions of Molecules at Electrode*, Wiley-Interscience, London, 1971, p. 229.
- 15 G. Huttner, H.H. Brintzinger, L.G. Bell, P. Friedrich, V. Benjenke and D. Neugebauer, *J. Organometal. Chem.*, 145 (1978) 329.
- 16 B.J. Huebert and D.E. Smith, *J. Electroanal. Chem.*, 31 (1971) 333.
- 17 R. Dietz and M.E. Peover, *Discuss. Faraday Soc.*, 45 (1968) 154.
- 18 J.D.L. Holloway, W.L. Bowden and W.E. Geiger, Jr., *J. Amer. Chem. Soc.*, 99 (1977) 7089.