

**THE STRUCTURE OF  
 3,4,5,6-TETRAHAPTOCYCLODECA-1,3,5,7-TETRAENE-TRICARBONYLIRON,  
 A PI COMPLEX OF A TEN-MEMBERED, MONOCYCLIC POLYOLEFIN**

F. ALBERT COTTON and JAN M. TROUP

*Department of Chemistry, Texas A & M University, College Station, Texas 77843 (U.S.A.)*

(Received November 24th, 1980)

**Summary**

The title compound, a minor product of the reaction of  $\text{Fe}_2(\text{CO})_9$  with bicyclo[6.2.0]deca-2,4,6-triene, crystallizes in space group  $P\bar{1}$  with  $a = 10.401(2)$  Å,  $b = 9.779(2)$  Å,  $c = 6.554(2)$  Å;  $\alpha = 98.69(2)^\circ$ ;  $\beta = 111.76(2)^\circ$ ;  $\gamma = 82.65(2)^\circ$ ;  $V = 610.1(2)$  Å<sup>3</sup>;  $Z = 2$ . The structure has been refined to  $R_1 = 0.029$  and  $R_2 = 0.036$ . No crystallographic symmetry is imposed on the molecule but it has an approximate mirror plane of symmetry. The  $\text{C}_{10}\text{H}_{12}$  ligand is present as a coordinated 1,3,5,7-cyclodecatetraene, coordinated to the  $\text{Fe}(\text{CO})_3$  group through the *cis,cis*-3,5-diene unit. The bond distances and angles within the local (butadiene) $\text{Fe}(\text{CO})_3$  moiety are normal, with one CO group lying over the open side of the butadiene chain. The central C—C distance is 0.028(9) Å shorter than the mean of the two outer C—C distances of the butadiene chain. The  $\text{C}_{10}$  ring lies in four planes with dihedral angles between adjacent planes (starting with the plane of the coordinated butadiene unit) of  $41.5^\circ$ ,  $50.6^\circ$  and  $53.8^\circ$ .

**Introduction**

Several years ago in this laboratory, the reaction of *cis*-bicyclo[6.2.0]deca-2,4,6-triene, I, with  $\text{Fe}_2(\text{CO})_9$ , was investigated, and it was found that a surprisingly multifarious mixture of products was obtained [1,2].

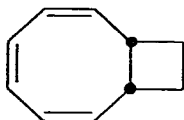

(I)

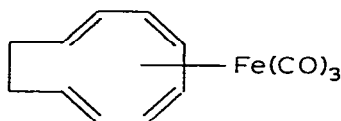

(II)

All of those that could be chromatographically separated and crystallized have

been thoroughly characterized by X-ray crystallography and, with the exception of the compound described here, full structural reports have been published [3–8]. There is still one of these compounds, shown schematically as II, which, though its structure has been briefly described [9], has not been presented in detail. We have completed the refinement and present here a final report on this compound.

## Experimental

### Preparation

Bicyclo[6.2.0]deca-2,4,6-triene, which was known to contain at least 5% cyclooctatetraene, was reacted with diiron nonacarbonyl in ether at 20°C as described previously [1,2]. The products were separated by chromatography on Woelm activity 2 alumina by eluting with hexane. The large yellow band [2] containing the previously identified product tricyclo[6.2.0.0<sup>2,7</sup>]-deca-3,5-diene-tricarbonyliron (C<sub>10</sub>H<sub>12</sub>)Fe(CO)<sub>3</sub>, which has been fully characterized by an X-ray structure determination [4], was rechromatographed several times on Woelm activity 2 alumina until the yellow band separated into two distinct bands. The first band contained only (tri-cyclo[6.2.0.0<sup>2,6</sup>]-C<sub>10</sub>H<sub>12</sub>)Fe(CO)<sub>3</sub> as identified by NMR, but the second band showed a very complex NMR spectrum indicating a mixture of products. This second band was evaporated to dryness in vacuum and crystals of [(C<sub>8</sub>H<sub>9</sub>)Fe(CO)<sub>3</sub>]<sub>2</sub> [8] were recovered by crystallization from (30–60°) petroleum ether at –5°C. A few crystals of the title compound (C<sub>10</sub>H<sub>12</sub>)Fe(CO)<sub>3</sub> were obtained by reducing to dryness in vacuum the mother liquor from the above crystallization and subliming the resulting solid at 40°C under atmospheric pressure. The IR spectrum in CS<sub>2</sub> showed strong carbonyl stretching bands at 2050, 1995 and 1990 cm<sup>-1</sup>.

### Data collection

A crystal measuring approximately 0.20 × 0.25 × 0.30 mm was selected for data collection and mounted in a thin glass capillary. The crystal was found to be triclinic and the space group  $P\bar{1}$  was assumed. This choice was later confirmed by the successful solution and refinement of the structure.

Preliminary examination of the crystal and data collection were performed on a Syntex  $P\bar{1}$  diffractometer. Unit cell dimensions and an orientation matrix for data collection were determined using the Syntex software after automatically centering fifteen reflections. The cell dimensions and other crystal data are given in Table 1. The width at half-height of 0.15° was obtained from  $\omega$  scans of strong reflections.

TABLE 1

CRYSTAL DATA FOR Fe(CO)<sub>3</sub>C<sub>10</sub>H<sub>12</sub>

$a = 10.401(2) \text{ \AA}$	triclinic
$b = 9.779(2) \text{ \AA}$	space group $P\bar{1}$
$c = 6.554(2) \text{ \AA}$	Mo- $K_{\alpha}$ radiation
$\alpha = 98.69(2)^{\circ}$	$\mu = 14.0 \text{ cm}^{-1}$
$\beta = 111.76(2)^{\circ}$	$Z = 2$
$\gamma = 82.65(2)^{\circ}$	
$V = 610.1(3) \text{ \AA}^3$	

The details of diffractometer operation and data collection are described elsewhere [3]. Data were collected at 22°C using the  $\theta$ - $2\theta$  scan technique and a scan rate which varied from 2.0 to 24.0°/min. depending on the intensity of the reflection. Unique data with  $2\theta$  (Mo- $K_{\alpha}$ ) values up to 45° were collected using a scan range of 0.8° before  $2\theta$  (Mo- $K_{\alpha_1}$ ) to 0.8° after  $2\theta$  (Mo- $K_{\alpha_2}$ ). Three standard reflections checked during the data collection showed good electronic and crystal stability.

An absorption correction was not made in view of the small variation in transmission factors during data collection. Lorentz and polarization corrections were made. Only 1091 reflections of the 1316 reflections collected were found to have  $F_0^2 > 3\sigma(F_0^2)$  and were used in the refinement of the structure.

#### *Solution and refinement of the structure [10]*

The iron atom was located using the Patterson method. Two cycles of least-squares refinement of the coordinates of the iron atom gave the following agreement factors:

$$R_1 = (\sum ||F_0| - |F_c||) / \sum |F_0| = 0.413$$

$$R_2 = (\sum w(|F_0| - |F_c|)^2 / \sum w|F_0|^2)^{1/2} = 0.478$$

where  $|F_0|$  and  $|F_c|$  are the observed and calculated structure factor amplitudes and  $w$  is the weighting factor given as  $4|F_0|^2/\sigma^2$ . Here  $\sigma$  is the e.s.d. of  $|F_0|^2$ . Scattering factors were taken from the International Tables [11]. Anomalous dispersion effects were included in the calculated structure factors for iron, using  $\Delta f'$  and  $\Delta f''$  values given by Cromer and Liberman [12].

A difference Fourier map based on the phases determined by the iron atom revealed the positions of all carbon and oxygen atoms. All non-hydrogen atoms were refined isotropically by two full matrix least-squares cycles and then anisotropically by four least-squares cycles to give the agreement indices of  $R_1 = 0.051$  and  $R_2 = 0.076$ . A difference Fourier map now showed the positions of all twelve hydrogen atoms. The non-hydrogen atoms were refined anisotropically and hydrogen atoms isotropically in three final least-squares cycles to give final agreement factors of  $R_1 = 0.029$  and  $R_2 = 0.036$ . In the final cycle of refinement no parameter shift exceeded 0.10 times the standard deviation in the parameter. The e.s.d. in an observation of unit weight was 1.147.

No systematic trends were found in the data as a function of  $\lambda^{-1} \sin \theta$ ,  $|F_0|$ , Miller indices, or reflection number. The atomic coordinates and thermal parameters with their estimated standard deviations are given in Tables 2 and 3, respectively. A final difference Fourier map was featureless\*.

## Results and discussion

The molecular structure is shown in Figs. 1 and 2. The atom numbering

---

\* See NAPS document no. 03817 for 19 pages of supplementary material. Order from NAPS c/o Microfiche Publications, P.O. Box 3513, Grand Central Station, New York, N.Y. 10017. Remit in advance, in U.S. funds only \$5.00 for photocopies or \$3.00 for microfiche. Outside the U.S. and Canada add postage of \$3.00 for photocopy and \$1.00 for microfiche.

TABLE 2  
 ATOMIC POSITIONAL AND ANISOTROPIC THERMAL PARAMETERS FOR  $\text{Fe}(\text{CO})_3\text{C}_{10}\text{H}_{12}$  FOR NON-HYDROGEN ATOMS

Atom	x	y	z	$\beta_{11}$	$\beta_{22}$	$\beta_{33}$	$\beta_{12}$	$\beta_{13}$	$\beta_{23}$
Fe	-0.09664(6)	-0.24183(5)	0.16263(8)	0.0114(1)	0.0089(1)	0.0298(2)	-0.0001(1)	0.0064(1)	0.0016(1)
O(1)	-0.1832(3)	0.314(3)	0.3888(5)	0.0185(5)	0.0120(4)	0.0561(12)	0.0006(4)	0.0074(6)	-0.0050(6)
O(2)	0.0745(3)	-0.3572(3)	0.5749(5)	0.0185(5)	0.0187(5)	0.0484(12)	-0.0012(4)	-0.0001(7)	0.0121(6)
O(3)	0.1535(4)	-0.1808(4)	0.1004(7)	0.0182(6)	0.0287(7)	0.0713(16)	-0.0078(5)	0.0186(9)	0.0021(8)
C(1)	-0.2735(5)	-0.3297(4)	0.1711(7)	0.0137(7)	0.0113(5)	0.0284(13)	-0.0029(5)	0.0065(8)	0.0032(7)
C(2)	-0.2160(4)	-0.4084(4)	0.0206(6)	0.0122(6)	0.0083(6)	0.0363(14)	-0.0012(4)	0.0052(8)	0.0028(7)
C(3)	-0.1888(5)	-0.3615(4)	-0.1411(7)	0.0131(7)	0.015(5)	0.0320(13)	0.0001(5)	0.0084(8)	-0.0038(7)
C(4)	-2171(5)	-0.2081(4)	-0.1761(6)	0.0128(6)	0.0127(5)	0.0255(11)	-0.0189(5)	0.0074(7)	0.0019(6)
C(5)	-0.3473(6)	-0.1221(4)	-0.2366(6)	0.0156(9)	0.0097(5)	0.0278(12)	-0.0013(6)	0.0064(9)	0.0034(6)
C(6)	-0.4734(6)	0.1607(4)	-0.3451(7)	0.0147(8)	0.0112(6)	0.0290(13)	0.0015(6)	0.0064(9)	0.0058(7)
C(7)	-0.5156(7)	-0.3065(5)	-0.4098(7)	0.0163(8)	0.0141(6)	0.0332(15)	-0.0030(6)	0.0062(10)	0.0015(7)
C(8)	-0.5462(6)	-0.3660(5)	-0.2325(8)	0.0147(8)	0.0138(6)	0.0432(17)	-0.0024(6)	0.0069(9)	0.0037(8)
C(9)	-0.5252(6)	-0.2718(5)	-0.0263(8)	0.0133(8)	0.0142(6)	0.0396(17)	0.0011(6)	0.0111(10)	0.0057(8)
C(10)	-0.4085(5)	-0.2492(4)	0.1361(7)	0.0135(8)	0.0137(6)	0.0324(14)	-0.0018(6)	0.0101(9)	0.0008(7)
C(11)	-0.1485(4)	-0.0738(4)	0.2707(6)	0.0119(6)	0.0096(5)	0.0353(13)	-0.0033(4)	0.0053(7)	0.0007(6)
C(12)	0.0075(5)	-0.3130(4)	0.4121(8)	0.0116(6)	0.0111(5)	0.0410(14)	-0.0012(5)	0.0056(8)	0.0021(7)
C(13)	0.0549(6)	-0.2055(4)	0.1220(7)	0.0159(8)	0.0139(6)	0.0461(17)	-0.0028(6)	0.0109(10)	0.0029(7)

TABLE 3

ATOMIC POSITIONAL AND ISOTROPIC THERMAL PARAMETERS FOR  $\text{Fe}(\text{CO})_3\text{C}_{10}\text{H}_{12}$  HYDROGEN ATOMS

Atom	x	y	z	$B_{\text{iso}}$
H(1)	-0.247(4)	-0.367(4)	0.306(7)	6.1(10)
H(2)	-0.180(4)	-0.498(4)	0.051(6)	5.5(9)
H(3)	-0.131(4)	-0.397(4)	-0.213(6)	4.1(9)
H(4)	-0.149(4)	-0.176(4)	-0.231(6)	5.4(10)
H(5)	-0.329(4)	-0.022(4)	-0.200(6)	5.3(9)
H(6)	-0.555(4)	-0.089(4)	-0.388(6)	5.3(9)
H(7)	-0.601(5)	-0.302(4)	-0.551(8)	8.0(12)
H(7')	-0.439(5)	-0.363(5)	-0.435(7)	6.9(13)
H(8)	-0.647(6)	-0.391(5)	-0.295(8)	8.3(14)
H(8')	-0.488(4)	-0.448(4)	-0.203(6)	5.0(9)
H(9)	-0.606(5)	-0.205(4)	-0.025(6)	6.0(10)
H(10)	-0.400(5)	-0.180(4)	0.274(8)	8.7(12)

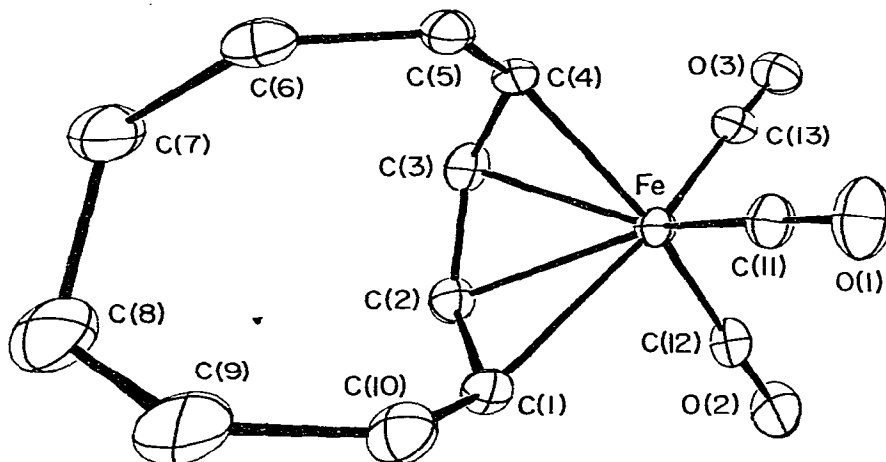
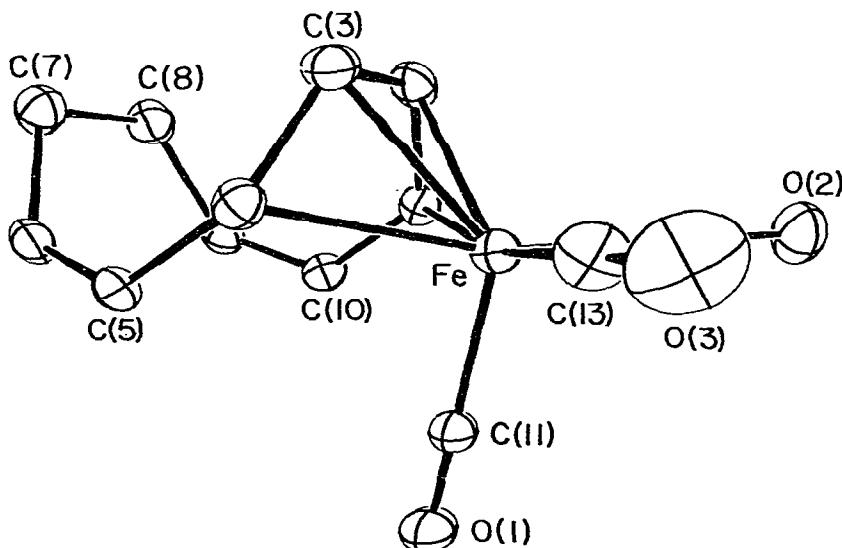
Fig. 1. An ORTEP drawing of the  $\text{C}_{10}\text{H}_{12}\text{Fe}(\text{CO})_3$  molecule omitting hydrogen atoms. The atom numbering scheme is defined.Fig. 2. An ORTEP drawing showing how the conformation of the  $\text{C}_{10}$  ring defines four planes.

scheme is fully defined in Fig. 1, which also makes clear the virtual mirror symmetry of the molecule. Figure 2 gives a particularly clear view of the folding of the ring. Tables 4 and 5 list the important distances and angles. In parts B and C of Table 4 pairs of distances that would be equal under rigorous mirror symmetry are grouped and their averages given. The three types of C—C bonds, viz.,  $C(sp^2)=C(sp^2)$ ,  $C(sp^2)-C(sp^2)$ ,  $C(sp^2)-C(sp^3)$ , and  $C(sp^3)-C(sp^3)$ , have average values of 1.314(6), 1.455(6), 1.482(6) and 1.528(6) Å, which are all

TABLE 4  
BOND LENGTHS (Å)

<i>A. In the Fe(CO)<sub>3</sub> unit</i>	
Fe—C(11)	1.789(4)
Fe—C(12)	1.780(5)
Fe—C(13)	1.778(6)
C(11)—O(1)	1.129(4)
C(12)—O(2)	1.150(5)
C(13)—O(3)	1.145(5)
<i>B. In the Fe-butadiene unit</i>	
Fe—C(1)	2.150(4)
Fe—C(4)	2.159(4)
Av	2.155(5)
Fe—C(2)	2.065(4)
Fe—C(3)	2.058(4)
Av	2.062(5)
C(1)—C(2)	1.419(6)
C(3)—C(4)	1.432(5)
Av	1.425(7)
C(2)—C(3)	1.397(6)
<i>C. In the C<sub>8</sub>H<sub>12</sub> ring</i>	
C(4)—C(5)	1.452(6)
C(10)—C(1)	1.458(6)
Av	1.455(6)
C(5)—C(6)	1.312(6)
C(9)—C(10)	1.315(6)
Av	1.314(6)
C(6)—C(7)	1.489(6)
C(8)—C(9)	1.476(6)
Av	1.482(6)
C(7)—C(8)	1.528(6)
<i>D. C—H distances</i>	
C(1)—H(1)	0.94(4)
C(2)—H(2)	0.93(4)
C(3)—H(3)	0.93(4)
C(4)—H(4)	1.00(4)
C(5)—H(5)	0.99(4)
C(6)—H(6)	1.01(4)
C(7)—H(7)	1.02(5)
C(7)—H(7)'	0.96(5)
C(8)—H(8)	1.02(5)
C(8)—H(8)'	0.94(4)
C(9)—H(9)	1.00(5)
C(10)—H(10)	1.03(5)
Av	0.98(5)

TABLE 5  
BOND ANGLES (deg)

<i>A. In the (butadiene)Fe(CO)<sub>3</sub> unit</i>	
Fe—C(11)—O(1)	178.9(4)
Fe—C(12)—O(2)	179.0(4)
Fe—C(13)—O(3)	178.6(4)
C(11)—Fe—C(12)	100.6(2)
C(11)—Fe—C(13)	100.7(2)
C(12)—Fe—C(13)	90.6(2)
C(11)—Fe—C(1)	92.0(2)
C(11)—Fe—C(4)	93.5(2)
C(11)—Fe—C(2)	127.9(2)
C(11)—Fe—C(3)	129.0(2)
C(12)—Fe—C(1)	89.2(2)
C(12)—Fe—C(2)	96.5(2)
C(12)—Fe—C(3)	126.4(2)
C(12)—Fe—C(4)	165.7(2)
C(13)—Fe—C(4)	89.3(2)
C(13)—Fe—C(3)	97.7(2)
C(13)—Fe—C(2)	128.1(2)
C(13)—Fe—C(1)	167.2(2)
<i>B. In the ring</i>	
C(1)—C(2)—C(3)	123.7(4)
C(2)—C(3)—C(4)	124.1(4)
C(2)—C(1)—C(10)	131.7(4)
C(3)—C(4)—C(5)	130.5(4)
C(4)—C(5)—C(6)	128.4(4)
C(1)—C(10)—C(9)	127.2(4)
C(5)—C(6)—C(7)	126.8(5)
C(8)—C(9)—C(10)	126.9(5)
C(3)—C(7)—C(8)	114.0(4)
C(7)—C(8)—C(9)	114.3(4)

in satisfactory accord with the accepted standard values. The C—H bond lengths vary from 0.93 to 1.03 Å, with a mean of 0.98 Å, which is quite a typical pattern for a structure determination of this sort.

In part B of Table 5 the ring angles are listed, with the pairs that would be identical under strict mirror symmetry grouped. In every pair, they are equal to within much less than  $3\sigma$ . The distribution of the angles around the ring is in accord with the arrangement of the single and double bonds. The angles at the saturated carbon atoms are about  $114^\circ$  while those at the  $sp^2$  carbon atoms are all larger, ranging from  $123.7^\circ$  to  $131.7^\circ$ .

The (butadiene)Fe(CO)<sub>3</sub> portion of the molecule is very typical in its conformation and dimensions [10]. The three Fe—CO distances are equal within the e.s.d.s and the Fe—C—O chains are nearly linear. The three carbonyl carbon atoms and the two outer carbon atoms of the butadiene moiety, C(1) and C(4), lie approximately at the vertices of a square pyramid; the midpoint of the C(2)—C(3) bond lies near, but not at, the position *trans* to the apical CO ligand. This is the normal stereochemical arrangement, with one CO group over the "open" side of the *cisoid* butadiene moiety. The ratio of the mean length of the outer C—C bonds, C(1)—C(2) and C(3)—C(4), to that of the inner C(2)—C(3), bond of the "butadiene" unit is  $>1$ . The difference, 0.028(0) Å, is similar to that found in many other cases [10]. The Fe—C(outer) and Fe—C(inner) bonds differ by 0.093(7) Å, which is, again, a typical value [10].

The conformation of the  $C_{10}H_{12}$  ring is shown in Fig. 2. The ring atoms define four planes,  $P_1-P_4$ :

$P_1$ : C(1), C(2), C(3), C(4)

$P_2$ : C(1), C(4), C(5), C(10)

$P_3$ : C(5), C(6), C(9), C(10)

$P_4$ : C(6), C(7), C(8), C(9)

The dihedral angles between these planes are:

$P_1/P_2$  41.5°

$P_2/P_3$  50.6°

$P_3/P_4$  53.8°

The distance of the iron atom from  $P_1$  is 1.55 Å.

The attachment of the ten-membered ring to the  $Fe(CO)_3$  unit presumably strongly stabilizes it against cyclization, since conrotatory cyclization [11] to a 6.2.0 bicyclic system would appear to require both conformational changes and shifts of the  $Fe(CO)_3$  group requiring large energies.

### Acknowledgement

We are grateful to The Robert A. Welch Foundation (Grant No. A-494) for financial support.

### References

- 1 F.A. Cotton and G. Deganello, *J. Amer. Chem. Soc.*, **94** (1972) 2142.
- 2 F.A. Cotton and G. Deganello, *J. Organometal. Chem.*, **38** (1972) 147.
- 3 F.A. Cotton, B.A. Frenz, G. Deganello and S. Shaver, *J. Organometal. Chem.*, **50** (1973) 227.
- 4 F.A. Cotton and J.M. Troup, *J. Organometal. Chem.*, **77** (1974) 369.
- 5 F.A. Cotton, B.A. Frenz and J.M. Troup, *J. Organometal. Chem.*, **61** (1973) 337.
- 6 F.A. Cotton, B.A. Frenz, J.M. Troup and G. Deganello, *J. Organometal. Chem.*, **59** (1973) 317.
- 7 F.A. Cotton and J.M. Troup, *J. Organometal. Chem.*, **76** (1974) 81.
- 8 F.A. Cotton and J.M. Troup, *J. Organometal. Chem.*, **77** (1974) 83.
- 9 F.A. Cotton and J.M. Troup, *J. Amer. Chem. Soc.*, **97** (1973) 3798.
- 10 F.A. Cotton, V.W. Day, B.A. Frenz, K.I. Harcastle and J.M. Troup, *J. Amer. Chem. Soc.*, **95** (1973) 4522.
- 11 S.W. Staley and T.J. Henry, *J. Amer. Chem. Soc.*, **92** (1970) 7612.