

## MASS SPECTROMETRY OF $\pi$ -COMPLEXES OF TRANSITION METALS

### XXIV \*. THE CYCLOPENTADIENYLTRICARBONYLRHENIUM (CTR) DERIVATIVES

V.F. SIZOI \*, Yu.S. NEKRASOV, Yu.N. SUKHAREV and N.E. KOLOBOVA

*Institute of Organoelement Compounds, U.S.S.R. Academy of Sciences, Vavilova St. 28, 117334 Moscow (U.S.S.R.)*

(Received November 18th, 1980)

#### Summary

Mass spectra of  $\eta^5\text{-RC}_5\text{H}_4\text{Re}(\text{CO})_3$ , where R = H, CH<sub>3</sub>, I, CH<sub>2</sub>OH, CHO, COOH, CN, COCH<sub>3</sub>, COOCH<sub>3</sub>, CH<sub>2</sub>Cl, CH=NC<sub>6</sub>H<sub>5</sub>, C(OH)(CH<sub>3</sub>)<sub>2</sub> or C(OH)-(C<sub>6</sub>H<sub>5</sub>)<sub>2</sub>, have been studied. The routes of fragmentation of the complexes under electron impact have been established. Dehydrogenation of decarbonylated ions follows the "intramolecular catalysis" mechanism and yields cluster ions with non-classical bonds. The main process of successive decarbonylation competes only with those decomposition reactions of the molecular ions which give stable 18-electron cations.

Mass spectra of cyclopentadienyltricarbonylrhenium, C<sub>5</sub>H<sub>5</sub>Re(CO)<sub>3</sub> (I), derivatives are little studied. King [1] has compared the mass spectra of CTR and its manganese analog C<sub>5</sub>H<sub>5</sub>Mn(CO)<sub>3</sub> (Ia). We have studied [2a] the effect of the  $\sigma$ -ligand on the fragmentation of cyclopentadienyl complexes of seven-coordinate rhenium, C<sub>5</sub>H<sub>5</sub>Re(CO)<sub>2</sub>XY, where X and Y are H, CH<sub>3</sub>, COCH<sub>3</sub>, Br, I or HgCl. Herrmann has published the mass spectra of RC<sub>5</sub>H<sub>4</sub>Re(CO)<sub>3</sub> (R = Cl, Br, I) [2b].

This paper is devoted to studying mass spectra of cyclopentadienyltricarbonylrhenium (I) and some of its derivatives (II–XIII).

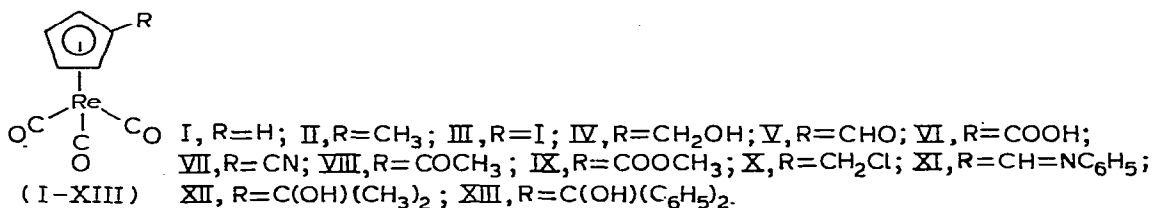

\* For part XXIII see ref. 10.

TABLE 1

STABILITY OF MOLECULAR IONS OF CTR AND CTM AND RELATIVE INTENSITY OF SOME PROCESSES IN THE MASS SPECTRA OF CTR DERIVATIVES (IN % OF TOTAL ION CURRENT)

Process	R =												
	H	CH <sub>3</sub>	I	CH <sub>2</sub> OH	CHO	COOH	CN	COCH <sub>3</sub>	COOCH <sub>3</sub>	CH <sub>2</sub> Cl	CH=NC <sub>6</sub> H <sub>5</sub>	C(OH)(CH <sub>3</sub> ) <sub>2</sub>	C(OH)(C <sub>6</sub> H <sub>5</sub> ) <sub>2</sub>
M <sup>+</sup> (CTR)	18	18	22	12	15	15	17	14	17	9	12	12	10
M <sup>+</sup> (CTM)	9	4	8	2	8	3	8	5	7	—	—	2	0.2
Decar-	51	46	30	27	33	31	45	32	27	31	53	6	26
Fragmentation of substituent	0	0	0	0	0	0.2	0	0.4	2	5	0	3	0
Dehydration	10	20	1	30	0	0	0	4	1	8	4	19	13
Destruction of ligand	5	1	8	1	0	0	3	0	0	2	0	0	0

SCHEME 1

DECOMPOSITION OF CTR DERIVATIVES UNDER ELECTRON IMPACT. THE TYPE OF PROCESS IS GIVEN IN THE BRACKETS

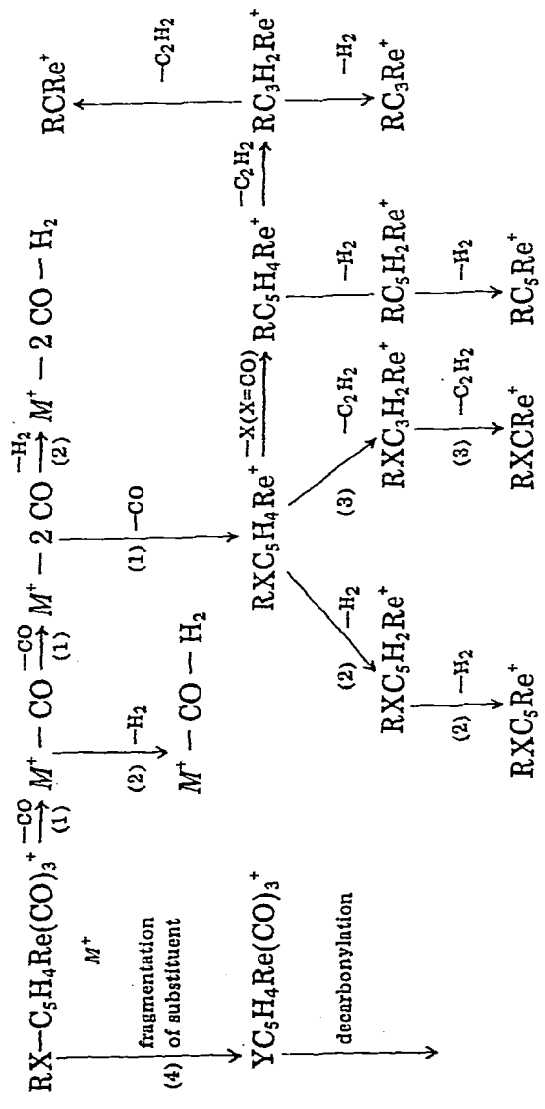

The mass spectra were computed to monoisotopic form by the AÉLTITA program [3].

The presence of intense molecular ion peaks in the mass spectra is a characteristic feature of the compounds under study. This points to a high stability of CTR derivatives towards electron impact as compared to other carbonyl complexes. Thus, the ratio of the molecular ion intensity to the total ion current is 2–6 times more in the case of CTR derivatives than in the mass spectra of CTM (Ia) and its derivatives (Table 1).

The fragmentation processes of the compounds under study can be divided into four groups (Scheme 1):

- 1) Decarbonylation of the molecular ion.
- 2) Dehydrogenation of decarbonylated ions.
- 3) Destruction of the cyclopentadienyl ring in the ion  $M^+ - 3 \text{CO}$ .
- 4) Fragmentation of a molecular ion with participation of atoms of substituent.

The intensity of each of these processes expressed in % of the total ion current is given in Table 1.

The main route of fragmentation of molecular ions of CTR derivatives consists of a successive elimination of carbonyl groups (Scheme 1) which yields intense  $M^+ - 3 \text{CO}$  ions which undergo destruction of the cyclopentadienyl ring. Thus, in the mass spectrum of  $\text{OHCC}_5\text{H}_4\text{Re}(\text{CO})_3$  (V) (Scheme 2) the

#### SCHEME 2

##### FRAGMENTATION OF $\text{OHCC}_5\text{H}_4\text{Re}(\text{CO})_3$

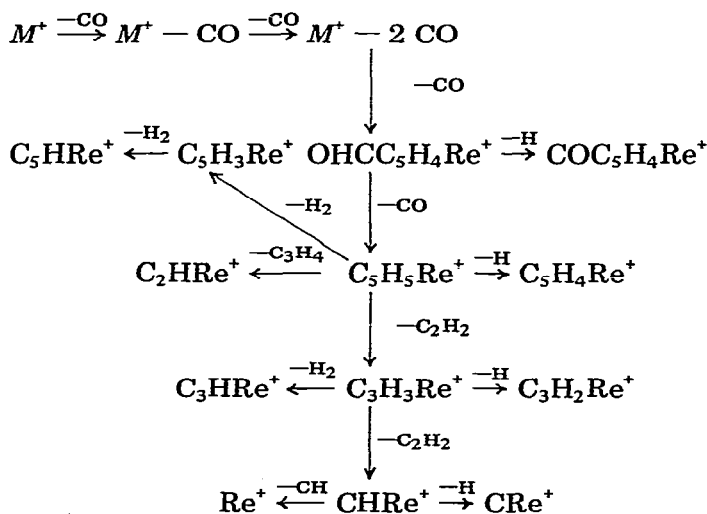

whole set of  $\text{C}_n\text{H}_m\text{Re}^+$  ions is present with  $n$  and  $m$  ranging from 5 to 0. Such cracking, as we have pointed out earlier [4], proceeds with participation of a rhenium atom by the "intramolecular catalysis" mechanism and are most pronounced for the systems with a large hydrocarbon ligand. Thus, in the mass spectrum of  $\text{C}_5\text{H}_5\text{Re}(\text{CO})_3$  (I) the  $M^+ - 3 \text{CO}$  ion eliminates 4 hydrogen atoms, whereas in mass spectra of  $(\text{CH}_3)_2\text{C}(\text{OH})\text{C}_5\text{H}_4\text{Re}(\text{CO})_3$  (XII) and  $(\text{C}_6\text{H}_5)_2\text{C}(\text{OH})\text{C}_5\text{H}_4\text{Re}(\text{CO})_3$  (XIII) this ion loses 6 and 7 hydrogen atoms, respectively;

the ion  $C_5H_5Re[C=C(C_6H_5)C(C_6H_5)=CH_2]ReC_5H_5^+$  in the mass spectrum of the corresponding tetracarbonyl complex eliminates 10 hydrogen atoms [4].

Complete dehydrogenation of  $C_5H_5Re^+$  yields  $C_5ReH^+$  ions which are present in the mass spectra of almost all compounds studied. Semi-sandwich cluster structures (XIV) with non-classical bonds can be assigned to these ions. The similar structure (XV) with a three-membered cycle can be assigned to  $C_3ReH^+$  ions formed after a successive loss of acetylene and hydrogen from the  $C_5H_5Re^+$  ions.

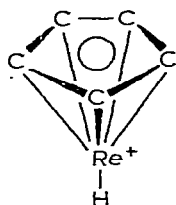

(XIV)

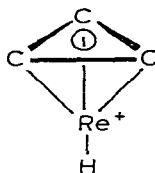

(XV)

The intensity of dehydrogenation differs at the various stages of decomposition and grows with increasing extent of decomposition of the molecular ion. In none of the cases do molecular ions eliminate hydrogen; The decarbonylated ions  $RC_5H_4Re(CO)_n^+$  ( $n = 0-2$ ) are subjected to dehydrogenation only in mass spectra of CTR derivatives with  $R = H, CH_3, CH_2OH, CH_2Cl, C(OH)(CH_3)_2$  and  $C(OH)(C_6H_5)_2$ , i.e. in the compounds with mobile hydrogen atoms. The selectivity of the process decreases with the extent of destruction of the ligand. In almost all cases hydrogen leaves the ions formed as a result of elimination of the substituent.

Dehydrogenation, proceeding by the "intramolecular catalysis" mechanism includes a hydrogen migration from the hydrocarbon ligand to the rhenium atom with the formation of hydride ions  $C_xH_yReH_z^+$  ( $z = 1$  or  $2$ ) which lose further hydrogen. The double bonds thus formed participate in additional coordination with the metal atom and compensate in this way for its coordinative unsaturation.

The behaviour described of rhenium complexes under electron impact correlates with the high catalytic activity of metallic rhenium in dehydration and dehydrocyclization reactions proceeding in the condensed phase [5].

The processes of partial or complete loss of the substituent compete with the main successive decarbonylation process of the molecular ion. For instance, the ions  $R'CO C_5H_4Re(CO)_3^+$  ( $R' = CH_3, OH, OCH_3$ ) lose  $R'$  with the formation of stable 18-electron cations  $CO C_5H_4Re(CO)_3^+$  in which the ligand has, evidently, the structure of 6-oxofulvene. Elimination of a chlorine atom, and methyl and hydroxy groups from the molecular ions  $ClCH_2C_5H_4Re(CO)_3^+$  (X) and  $(CH_3)_2C(OH)C_5H_4Re(CO)_3^+$  (XII) yields cations of the same type. The resulting ions  $M^+ - Cl, M^+ - CH_3$  and  $M^+ - OH$  have the structures of the 18-electron cations XVI, XVII, and XVIII. The presence of hydrocarbon ions with  $m/z$  78 and 106 (corresponding to the loss of  $Re(CO)_3$  from the ions XVI and XVIII) in mass spectra of X and XII confirms the proposed structures.

Thus, decarbonylation competes only with those reactions of decomposition of a molecular ion which give stable 18-electron cations, i.e. when the energy

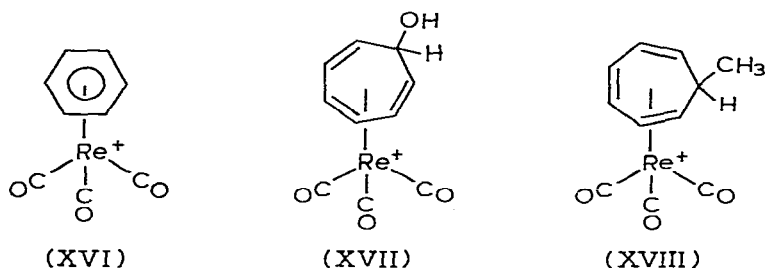

required for breaking the stable bonds is compensated for by the high stability of the products obtained.

The decomposition of the carbinol XII is rather interesting. The main fragmentation routes of its molecular ion are presented in Scheme 3.

#### SCHEME 3

DECOMPOSITION OF  $(\text{CH}_3)_2\text{C}(\text{OH})\text{C}_5\text{H}_4\text{Re}(\text{CO})_3$  (XII) UNDER ELECTRON IMPACT

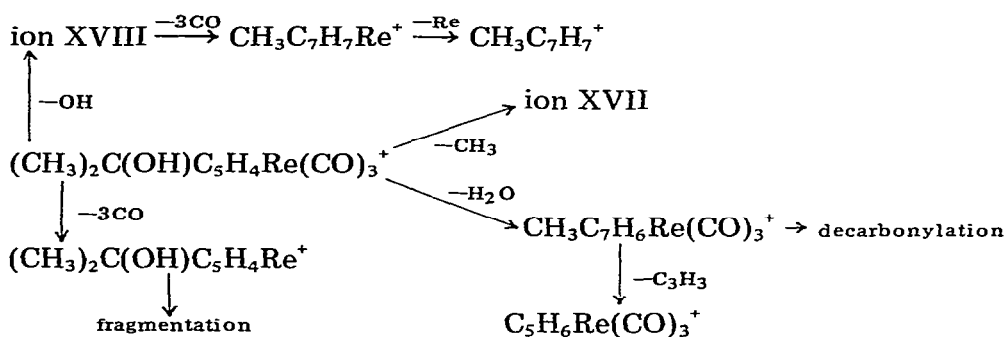

The mass spectrometric decomposition of this compound is one of the rare examples of a substantial inhibition of decarbonylation by the energetically more favourable reactions forming cations stable in the gas phase. The molecular ion  $(\text{CH}_3)_2\text{C}(\text{OH})\text{C}_5\text{H}_4\text{Re}(\text{CO})_3^+$  decomposes in four directions:

- 1) Loss of three carbonyl groups. The ion  $M^+ - 3\text{CO}$  formed loses a water molecule, hydrogen, and carbon oxide.
- 2) Loss of methyl group. Ion XVII ( $m/z$  379) is formed.
- 3) Loss of hydroxyl group. Ion XVIII formed loses three carbonyl groups and then the rhenium atom.
- 4) Dehydration.

In the mass spectrum of the corresponding derivative of CTM,  $(\text{CH}_3)_2\text{C}(\text{OH})\text{C}_5\text{H}_4\text{Mn}(\text{CO})_3$ , the  $M^+ - \text{H}_2\text{O}/M^+$  ratio is 0.7 [6]; when manganese is replaced with rhenium this ratio decreases almost fivefold. If the dehydration of rhenium complexes follows the same mechanism as that of cymantrenylcarbinols, i.e. a preliminary migration of a hydroxy group to a positively charged metal atom, the observed decrease in intensity of dehydration in going from manganese to rhenium may be related to the greater distance between the hydroxy group and the rhenium atom in the molecular ion  $(\text{CH}_3)_2\text{C}(\text{OH})\text{C}_5\text{H}_4\text{Re}(\text{CO})_3^+$  [7].

A characteristic feature of mass spectra of CTR derivatives is the complete absence of  $\text{RRe}^+$  ions, corresponding to rearrangement processes of type 5 com-

mon in mass spectra of CTM derivatives [8]:



Even such substituents as chlorine, hydroxyl, or phenyl do not migrate. This may be due to both the greater strength of the  $\text{C}_5\text{H}_5-\text{Re}$  bond as compared to the  $\text{C}_5\text{H}_5-\text{Mn}$  bond, the greater distance between the rhenium atom and a radical at an  $\alpha$ -carbon atom of the substituent, and the low stability of  $\text{RRe}^+$  ions in which rhenium is formally bivalent. It is known that the bivalent state is not common for rhenium [9]. The latter factor is, evidently, dominating, which agrees with the mass spectrum of  $\text{CH}_3\text{OOC}\text{C}_5\text{H}_4\text{Re}(\text{CO})_2\text{Br}_2$ , in which ions  $\text{CH}_3\text{OReBr}_2^+$  with stable tetravalent rhenium are present [2a]. These ions are formed as a result of the loss of  $\text{C}_5\text{H}_4\text{CO}$  from  $\text{CH}_3\text{OOC}\text{C}_5\text{H}_4\text{ReBr}_2^+$ .

### Experimental

Mass spectra were recorded on MX-1303 and AEI MS-30 mass spectrometers with a DS-50 data acquisition system; the temperature of direct introduction system was 20–100°C and the temperature of the source was 150–200°C; the ionizing voltage was 50–70 V.

### Acknowledgement

The authors express their deep gratitude to Z.P. Valueva, A.G. Ginzburg, Yu.V. Makarov and M.Ya. Solodova for the samples of the compounds studied in this work.

### References

- 1 R.B. King, *J. Amer. Chem. Soc.*, **90** (1968) 1417.
- 2 (a) V.F. Sizoi, Yu.S. Nekrasov, Yu.V. Makarov and N.E. Kolobova, *J. Organometal. Chem.*, **94** (1975) 425. (b) W.A. Herrmann, *Chem. Ber.*, **111** (1978) 2458.
- 3 Yu.N. Sukharev and Yu.S. Nekrasov, *Org. Mass Spectrom.*, **11** (1976) 1232.
- 4 V.F. Sizoi, Yu.S. Nekrasov, Yu.N. Sukharev, N.E. Kolobova, O.M. Khitrova, N.S. Obezyuk and A.B. Antonova, *J. Organometal. Chem.*, **162** (1978) 171.
- 5 V.A. Roiter (Ed.), *Catalytic properties of compounds*, Vol. 4, Naukova Dumka, Kiev, 1977.
- 6 Yu.S. Nekrasov, V.F. Sizoi, D.V. Zagorevskii and N.I. Vasykova, *Org. Mass Spectrom.*, **14** (1979) 22.
- 7 V.G. Andrianov, B.P. Biryukov and Yu.T. Struchkov, *Zh. struct. khimii*, **10** (1969) 1129.
- 8 N. Maoz, A. Madelbaum and M. Cais, *Tetrahedron Lett.*, (1965) 2087.
- 9 E.V. Nekrasov, *Principles of General Chemistry*, Vol. 1, Khimiya, Moscow, 1965, p. 296.
- 10 Yu.S. Nekrasov, V.F. Sizoi, D.V. Zagorevskii and Yu.A. Borisov, *J. Organometal. Chem.*, **205** (1981) 157.