

BORON: BORANES IN ORGANIC SYNTHESIS
ANNUAL SURVEY COVERING THE YEAR 1981*

George W. Kabalka

Department of Chemistry
University of Tennessee
Knoxville, TN 37996 (USA)

CONTENTS

A.	INTRODUCTION	2
B.	BORANE REAGENTS	2
1.	Hydroborating Agents	2
a.	BH ₃	2
b.	RBH ₂	2
c.	R ₂ BH	3
2.	Reducing Agents	4
a.	BH ₃	4
b.	RBH ₂	5
c.	R ₂ BH	5
d.	R ₃ B	6
e.	R ₄ B-M ⁺	6
3.	Mechanism and Theory	7
C.	CARBON-CARBON BOND FORMATION	10
1.	Homologation	10
2.	Alkenylborate Rearrangements	12
3.	Alkynylborate Rearrangements	13
4.	Allylboranes	15
5.	Enol Borinates	16
6.	Boraadamantanes	18
D.	CARBON-HETEROATOM BOND FORMATION	19
1.	Group VII	19
2.	Group V	21
E.	HYDROBORATION OXIDATION/PROTONOLYSIS	21
1.	Natural Products	21
2.	General Synthetic Applications	22
F.	REFERENCES	23

*Boron: Boranes in organic synthesis; Annual Survey covering the year 1980; by D.S. Matteson see J. Organometal. Chem., 227 (1982) 165-197.

A. INTRODUCTION

The organoboranes are playing an ever increasing role in organic synthesis. Professor Brown continues his pioneering studies and is, once again, the leading contributor in the field. A large percentage of the research presented in this survey was carried out by former students of Professor Brown but there is an increasing number of chemists of diverse backgrounds who are discovering the utility of the organoboranes. The contributions of these scientists will surely cause even more rapid expansion in the organoborane area.

I have attempted to present organoborane chemistry in the format which has worked so effectively in the past. As always, classification of data is sometimes arbitrary but hopefully logical. As an example, classification B.2.c. contains dialkoxyboranes as well as the more conventional dialkylborane derivatives. Reviews are cited in the topic in which they belong; thus a survey of vinylboranes is found in classification C.3 (alkenylboranes).

B. BORANE REAGENTS

1. Hydroborating Agents

a. BH_3

Hydroboration is fundamental to the organoborane field. Considerable effort continues in the search for new and more specific hydroborating agents. However, the older reagents have not been forgotten. Pelter and his coworkers studied the hydroboration of alkenes utilizing nitrogen and phosphorous complexes of borane [1]. In general, they found that trialkylamine and pyridine complexes of borane gave

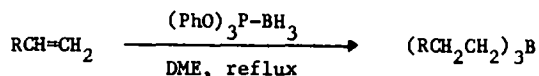

modest yields of the trialkylborane (~40%) when reacted with an alkene at reflux for two hours. Increased yields were obtained (~75%) when methyl iodide was added to the reaction mixture. Ph_3P and $(PhO)_3P$ complexes are more effective than amine complexes with $(PhO)_3P$ being the most efficient. Even though complexation of borane with amines occurs readily, unsaturated amines can be hydroborated to yield aminoalcohols after oxidation of the intermediate [2].

b. RBH_2

Brown has continued to develop isopinocampheylborane as an asymmetric hydroborating agent [3]. The reagent hydroborates trans alkenes with exceptionally high asymmetric induction [enantiomeric purities are in the range of 70-92% ee].

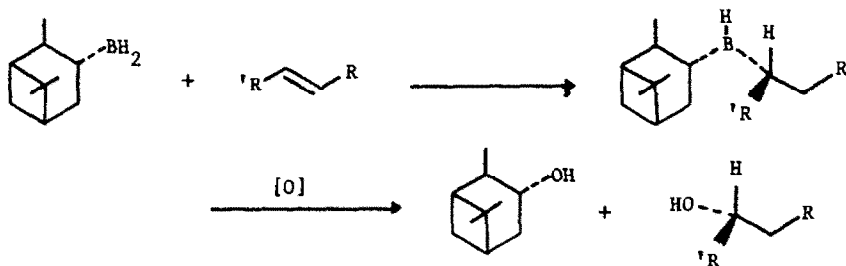

Brown and his workers have reviewed the use of chiral organoboranes in asymmetric syntheses (97 references) [4].

An interesting preparation of monoalkylboranes was reported which utilizes the reaction of alkylidenetriphenylphosphoranes with borane [5].

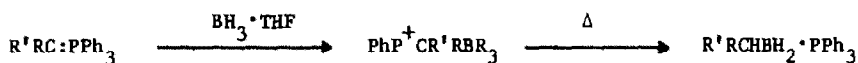

c. R_2BH

Dialkylboranes such as 9-BBN continue to be important in synthetic procedures as summarized in Section C. Soderquist and Brown reported an improved synthesis of 9-BBN involving the use of monoglyme (1,2-dimethoxyethane) as a solvent instead of THF [6]. The use of monoglyme as a recrystallization solvent makes purification of 9-BBN rather straightforward.

Brown and Chen examined the use of 9-BBN for hydroborating functionally substituted alkenes [7]. 9-BBN hydroborates terminal alkenes with remote functionality with remarkable regioselectivity (>98%). As the functional groups approach the alkene site, selectivity becomes dependent on the inductive and mesomeric effects of the functional groups. They found some unusual condensation reactions occurred in the hydroboration of crotyl esters.

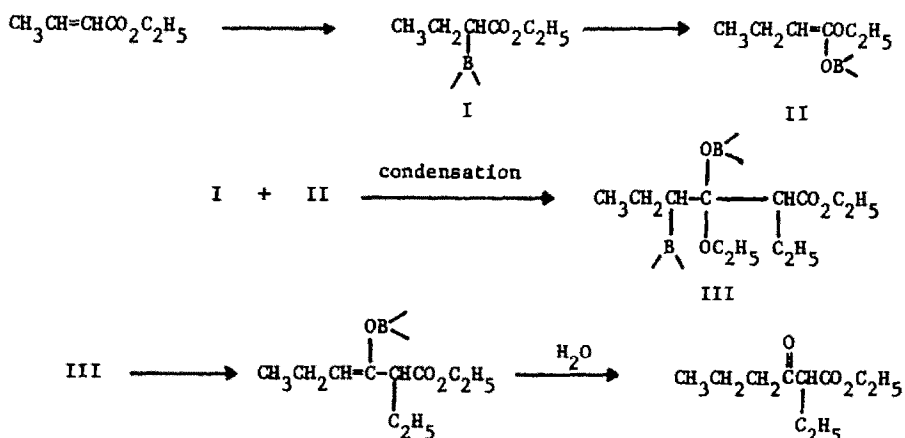

Brown and Jadhav reported the synthesis of a new chiral hydroborating agent, dilongifolylborane [8].

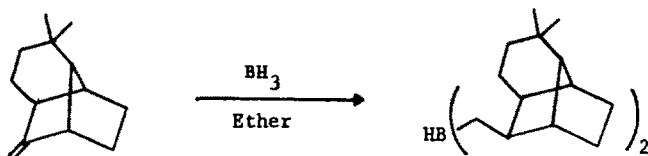

The new agent will hydroborate *cis* alkenes and trisubstituted prochiral alkenes to provide alcohols with optical purities in the 60-78% ee range with the new asymmetric center being predominately the R enantiomer. The reagent is better than the isopinocampheylborane reagents for hydroborating trisubstituted olefins.

Brown and Kulkarni have reported that dialkylboranes are readily prepared via the hydridation of dialkylhaloboranes [9]. Since a number

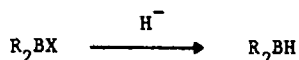

of dialkylhaloboranes are available via the reaction of monohaloborane complexes with alkenes, a variety of dialkylboranes can be prepared which are not currently available via hydroboration with BH_3 itself. Pelter and his coworkers utilized the same concept to prepare a mixed trialkylborane starting with dialkylbromoboranes [10].

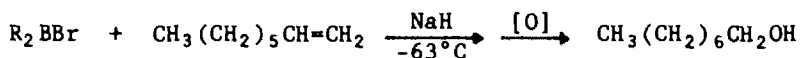

Contreras and Wrackmeyer examined the hydroboration of 3-methyl-1,3-butadiene with 1,2:1,2-bis(tetramethylene)diborane [11].

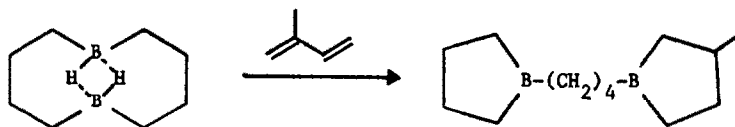

A polish group studied the synthesis of trialkylboranes via transmetallation reactions with organoaluminum reagents [12].

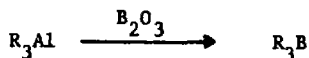

2. Reducing Agents

a. BH_3

Borane complexes have demonstrated great utility as reducing

agents. Brown reports that borane-dimethyl sulfide is very effective for the reduction of nitriles [13] and amides [14]

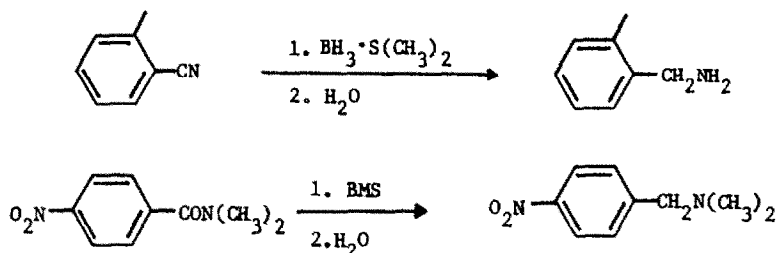

It has been reported that borane complexed with chiral amines will asymmetrically reduce ketones [15].

b. RBH_2

Another asymmetric reduction was achieved using chiral alkoxy-amine-borane complexes [16] formed via the reaction of (S)-(-)- $HOCH_2CH(NH_2)CHMe_2$, IV, with BH_3 . The reagent yields complex, V, which

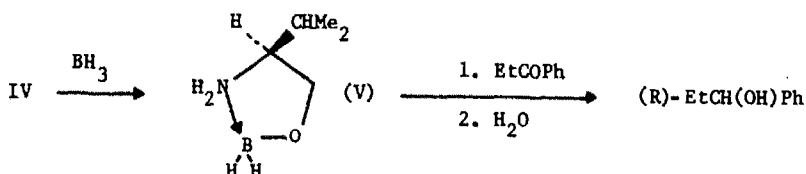

will reduce propiophenone to the corresponding alcohol (60% e.e. of R isomer).

c. R_2BH

Maryanoff reports that bis(trifluoroacetoxy)borane will reduce indoles, ketones, imines, and compounds that generate carbocations but that alkenes, acetylenes and carboxylic acids are not reduced [17]. The paper is very thorough and the reducing properties of the reagent are

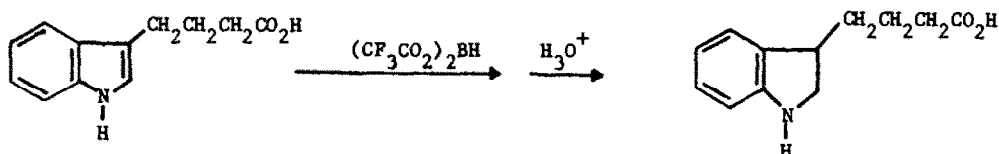

compared to the reducing properties of other borane reagents.

Kabalka and Summers continued their investigation of the reduction of tosylhydrazone derivatives of ketones and aldehydes using dialkoxyboranes [18]. The method offers a mild alternative to the Wolff-Kishner and Clemmensen reductions.

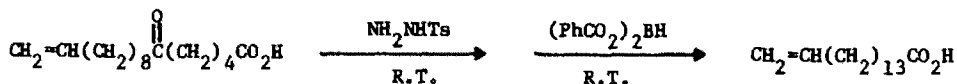

Zaidlewicz and Mokhtas studied the stereoselective reduction of α,β -epoxyketones with 9-BBN [19]. They found that 9-BBN exhibits greater stereoselectivity than B_2H_6 in the reduction of α,β -epoxyketones to α,β -epoxyalcohols.

d. R_3B

Midland and his coworkers continue to develop "alpine" borane (B-3-pinanyl-9-BBN) as a reagent for asymmetric reductions. They have utilized the reagent to prepare a series of chiral hydroxycarboxylic acids [20]

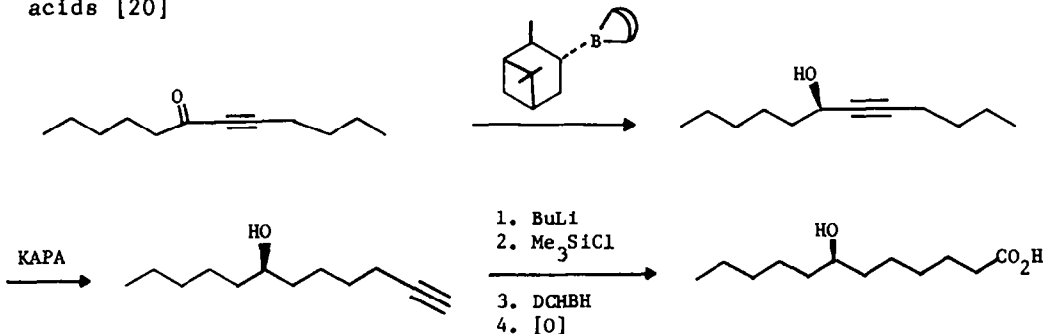

and lactones [21].

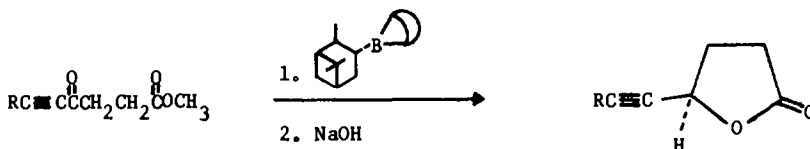

Johnson used the reagent to synthesize a polyunsaturated alcohol intermediate in a synthesis of corticoids [22].

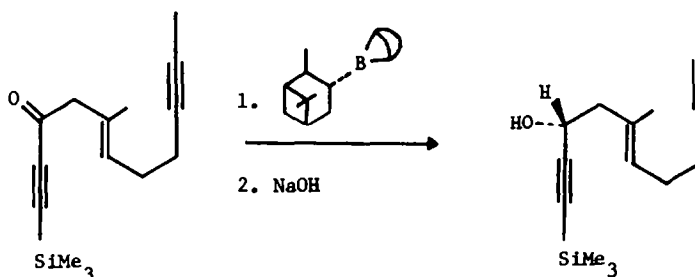

e. R_4B^-

A variety of borate anions are effective reducing agents. Brown, Singaram, and Hubbard reported that lithium trialkylborohydrides can be prepared via the reaction of $LiAlH_4$ with trialkylboranes in the presence of $Et_2NCH_2CH_2NHet$ [23]. They prepared a variety of trialkylborohydrides. Highly hindered reagents such as VI are useful for stereoselective reductions of ketones.

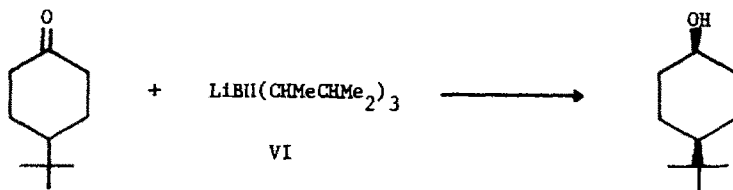

Brown, Singaram, and Mathew examined the preparation of dialkyl- and monoalkylborohydrides using saline hydrides [24] and lithium aluminum hydride [25]. The rate, stoichiometry, and products of the reactions were studied under a variety of conditions. [The boron-11 NMR parameters of the products are tabulated].

Makhlouf and Rickborn report that L-Selectride will selectively reduce the least hindered carbonyl in a substituted phthalic anhydride [26]. This contrasts with the nonselective reductions achieved using LiBHET_3 and NaBH_4 .

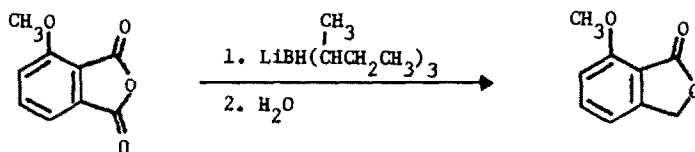

Lithium 9,9-di-n-butyl-9BBN reduces tertiary alkyl, benzyl, and allyl halides to the corresponding hydrocarbons [27].

Tetraethylammonium borohydride and tetrabutylammonium borohydride were used to reduce aldehydes and ketones. They demonstrated no selectivity when compared to sodium borohydride but the ammonium salts are soluble in methylene chloride and chloroform and may be of value in certain syntheses [28].

3. Mechanism and Theory

A variety of spectroscopic studies were performed on borane complexes and on organoboranes. The studies encompassed mechanistic and structural characteristics of a number of reagents and reactions. Duncan and coworkers carried out a careful IR and Raman study of B_2H_6 and B_2D_6 [29]. They also reported on the high resolution infrared of $^{10}\text{B}_2\text{D}_6$. Sets of upper-state parameters were determined for all 5 bands studied [30].

Ramsey and Isabelle utilized UV-visible, ESR, and NMR spectroscopy to examine the reaction between trimesitylborane and alkyl lithium [31]. The evidence strongly supports the formation of anion, VII, which is stabilized by B-C 2p- π bonding from a non-adjacent boron atom.

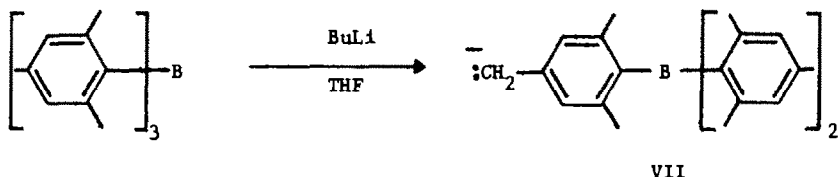

Interestingly, reaction of tri-m-xylylborane with n-butyllithium, under the same conditions, resulted in the formation of the tri-m-xylylborane radical anion, VIII, and not boron-stabilized anions.

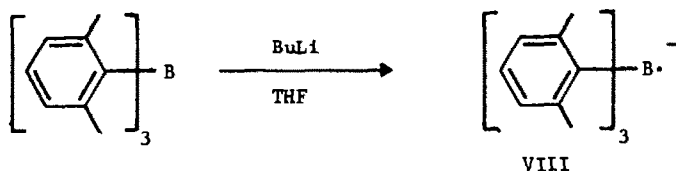

Davidson and Wilson carried out a mass spectrometric study on a series of twenty-nine dimesitylborane derivatives. In general, the compounds gave parent ions in high abundance except for t-butyl and benzyl derivatives [32].

In a separate study, ^{13}C , ^{11}B , and ^1H NMR investigations were carried out on trimesitylborane and a series of substituted dimesitylboranes [33]. The evidence clearly support the concept of π electron back-donation to the empty p orbital on boron.

Proton NMR was used to investigate the mechanism of the reaction between trialkylboranes and dialkyl(alkylperoxy)boranes [34]. Utilizing deuterated reagents and observing CIDNP effects, the authors conclude that the reaction involves the transfer of an alkoxy group from the peroxide to the boron atom of the trialkylborane (after homolysis of the peroxide linkage). The four coordinate alkoxyborane eliminates an alkyl radical which couples with the boroxyl radical left after the homolysis of the peroxide.

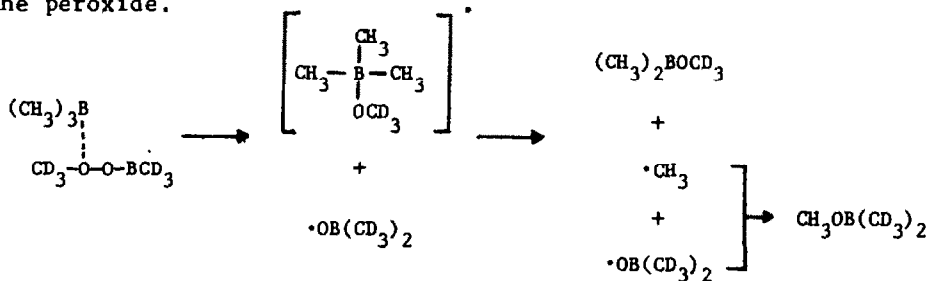

Mikhailov utilized ^1H NMR to study the conformation of 3-borabicyclo[3.3.1]nonanes [35,36]. He concluded that the conformation of IX involves a compressed double chair unless the boron is coordinated; in which case, the cyclohexane ring adopts the boat conformation.

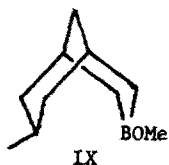

^{11}B and ^{13}C NMR studies of tetraphenylborate [37] and a series of benzannelated heteroboranes [38] were reported.

Van der Kerk investigated 1-methylborepin using NMR and concluded that it was aromatic [39].

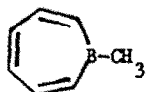

The degenerate 1,3-shift rearrangements of allylborane have been mapped by the PRDDO method. The rearrangements conform to the pseudo-pericyclic concept when it is recognized that a general feature of electron deficient sigmatropic migrations is the existence of polycyclic transition state binding [40]. The PRDDO method was also used to investigate pathways for both the Markovnikov and anti-Markovnikov addition of BH_3 to propylene and to acrylonitrile [41]. Markovnikov addition to propene is preferred by 1.1 kcal/mol whereas anti-Markovnikov addition to acrylonitrile is preferred by 1.6 kcal/mol. The regioselectivity of the hydroboration reaction appears to arise from electronic effects induced by electron-donating or withdrawing substituents when steric effects are negligible.

Brown and Pai used IR spectroscopy to examine the role of steric effects in the stability of addition compounds of borinane with amines [42]. They found that borinane complexes completely with most trialkylamines except for very hindered ones.

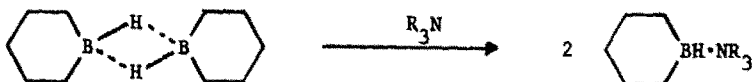

The data supports the conclusion that borinane is much less sterically hindered than 9-BBN. Brown also investigated the effect of steric crowding in the isomerization of trialkylboranes [43]. They found that the thermal isomerization of $\text{B}-(3\text{-hexyl})\text{bis}(2,5\text{-dimethylcyclohexyl})\text{-borane}$ is 100 x faster than the isomerization of the corresponding dicyclohexyl derivative and 40,000x faster than the $\text{B}-(3\text{-heptyl})\text{-9-BBN}$ derivative.

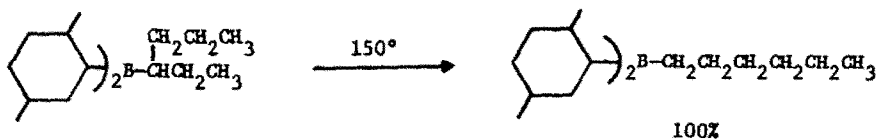

C. CARBON-CARBON BOND FORMATION

1. Homologation Reactions

A number of organoborane homologation reactions have been developed over the years. These include the carbonylation, cyanidation, DCME, and related reactions. The carbonylation reaction was applied to the synthesis of methylene cycloalkanes by Brown and Ford. They reported that methylene cycloalkanes can be prepared via the hydroboration-carbonylation of cycloalkenes [44]. The method is limited to those substrates which hydroborate regioselectively.

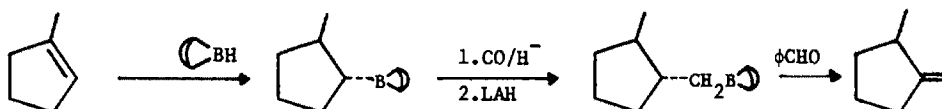

Bryson investigated the hydroboration-carbonylation of trienes in the formation of carbocyclic ring systems [45]. He reported that the hydroboration-carbonylation of 6,10-dimethyl-1,5,9-undecatriene yielded a mixture of the following alcohols after oxidation.

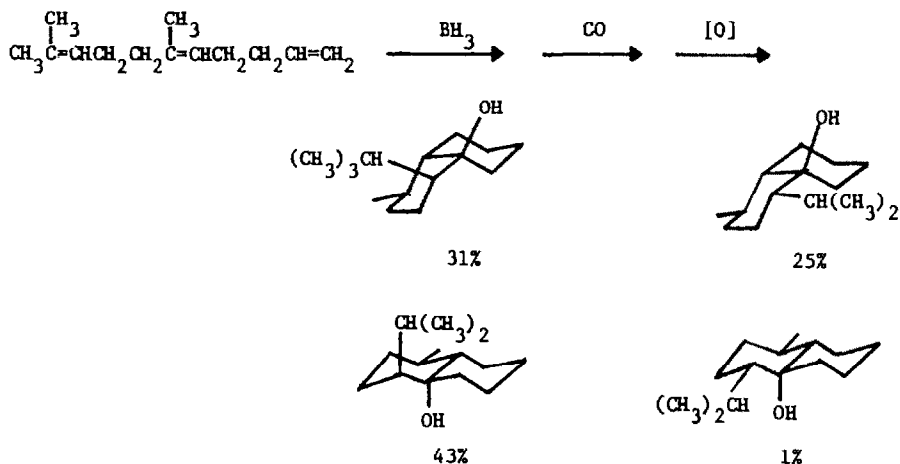

Prager and Murphy utilized the cyanidation reaction to form the cycloheptanediol monoacetate, X, from linalyl acetate [46].

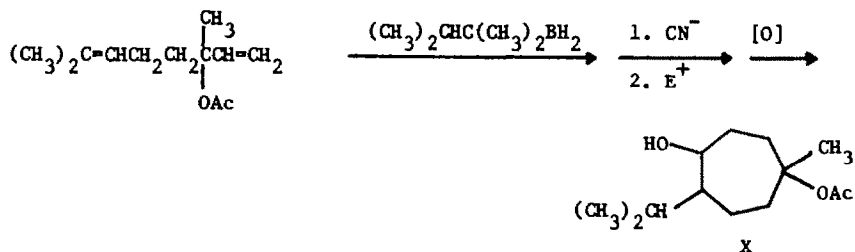

Larsen and Prieto prepared a series of alkylated cyclopentanol and cyclohexanol via the hydroboration of silylated enol ethers [47].

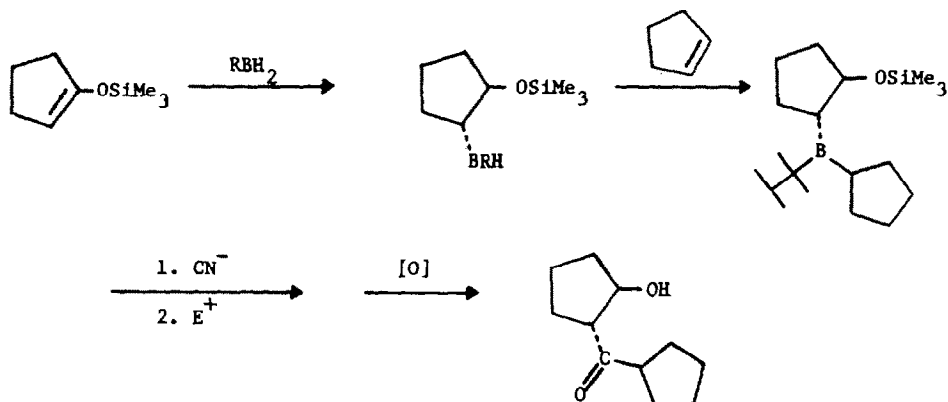

δ -Coniceine was prepared via reductive cyclization of XI which was synthesized in 35% yield from the bisolefinic amine, XII [48].

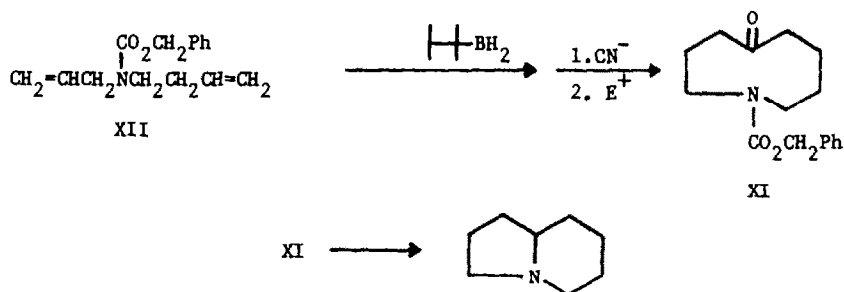

Pelter has developed a new synthesis of ketones and trialkylcarbinols using the reaction of lithium tris(phenylthio)-methanide with trialkylboranes [49]. The reaction is analogous to the carbonylation and dichloromethyl ether reactions.

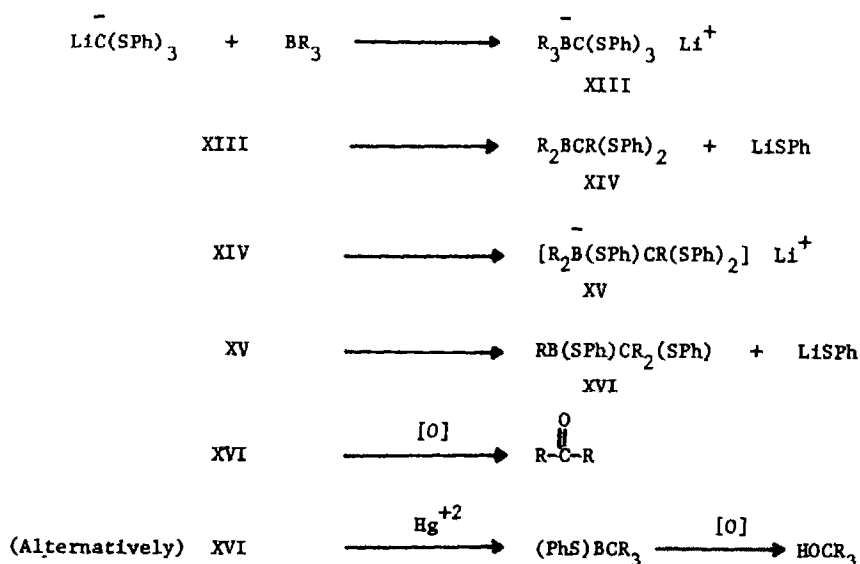

Two of the alkyl groups migrate spontaneously to yield XVI which may be oxidized to the corresponding ketone. The third alkyl group will migrate in the presence of electrophiles such as Hg^{+2} . Interestingly, a hexyl group migrates faster than a n-hexyl group.

2. Alkenylborate Rearrangements

Alkylalkenylborates react with various electrophiles or oxidizing agents to join the alkyl and alkenyl groups. The reactions proceed with a high degree of stereochemical control. The preparation and reactions of vinylboranes have been reviewed [50,51].

Zweifel and Pearson report that 1-alkenylallenic boranes, are readily available via the rearrangement of the borate complex XVII which is prepared via the hydroboration of an alkyne with hexylchloroborane followed by reaction with lithium chloropropargylide [52].

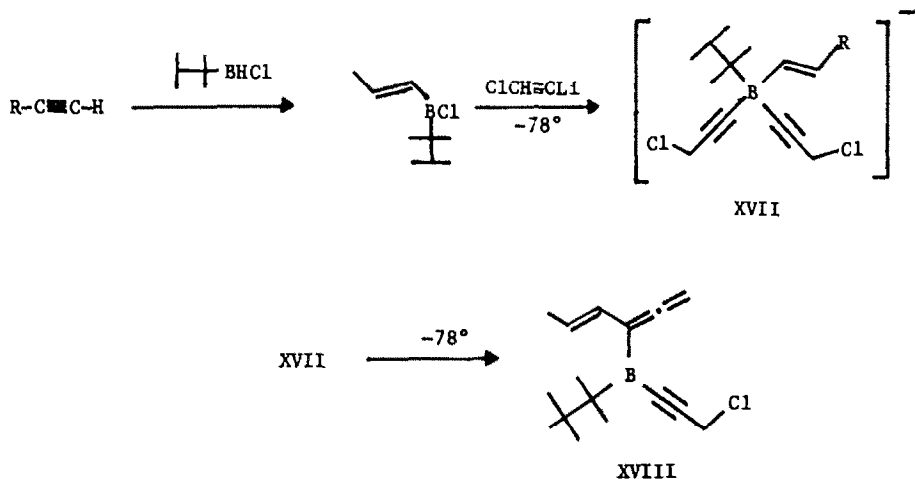

The allenic borane, XVIII, will rearrange to the corresponding propargylicborane, XIX.

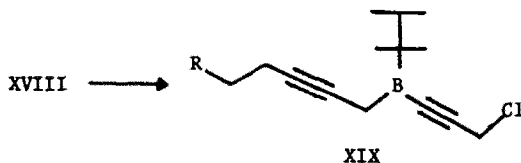

Borane XVIII and XIX will add to aldehydes to form 1,3-enynols and 1,2,4-trienols respectively.

Brown, Singaram, and Molander used alkylisocyanates to rearrange a series of B-(1-alkenyl)dialkylboranes to form heterocycle, XX [53]. These materials are readily solvolized.

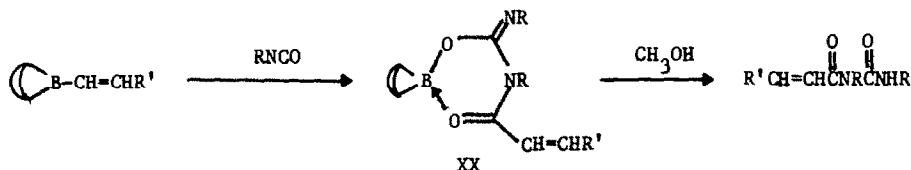

The use of dicyclohexylborane derivatives results in migration of one of the cyclohexyl groups and leads to a different product.

Brown and Molander have synthesized conjugated enynes via the reaction of copper iodide with vinylboranes and haloalkynes [54]. The reaction presumably proceeds via a vinyl copper intermediate.

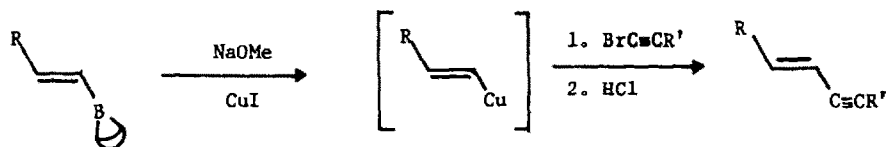

Suzuki and his coworkers have developed a stereospecific synthesis of conjugated (E,Z)- and (Z,Z)-alkadienes by a palladium-catalyzed cross coupling reaction of 1-alkenyl-boranes with 1-alkenylbromides [55].

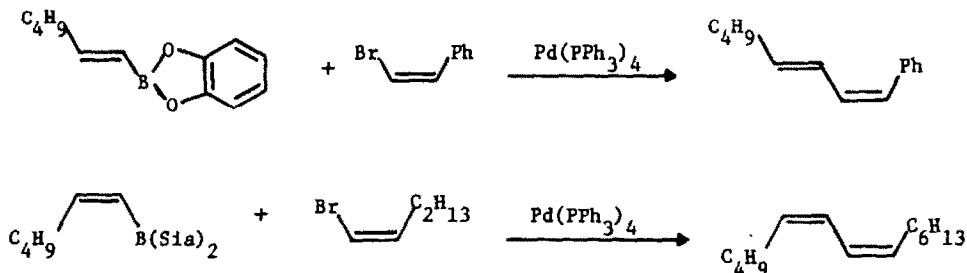

3. Alkynylborate Rearrangements

Alkynylborate complexes undergo rearrangements analogous to those of the alkenylborate complexes. Slayden has investigated the migratory aptitudes of various alkyl groups in the iodine induced rearrangements of lithium ethynyltrialkylborates [56]. The overall migratory aptitude order is bicyclooctyl > *n*-butyl > cyclohexyl > isobutyl > *sec*-butyl > *thexyl*. The general order is primary > secondary > tertiary which is compatible with the anionotropic nature of the rearrangements. As in many organoborane reactions, however, steric factors may predominate in some instances.

The iodine induced rearrangement of an alkynylborate complex was utilized to prepare a key intermediate in the synthesis of the sex pheromone of *Antheraea polyphemus*, XXI [57]

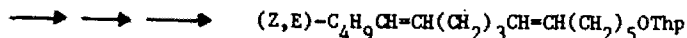
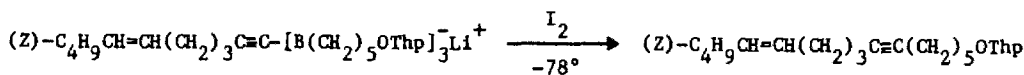

XXI

Bihlmayer and Wrackmeyer report that alkynylborate complexes result when alkynyl stannanes react with 9-ethyl-9-BBN [58].

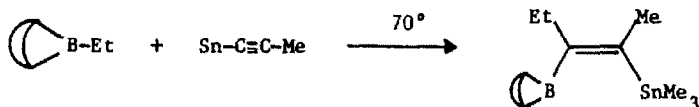

They also report unexpected products form when t-butyl alkynylstannane derivatives are reacted with 9-BBN [59]. As an example, the reaction of 9-BBN with XXII yields XXIV which they postulate arises via an alkynylborate intermediate (XXIII). When the t-butyl group is replaced

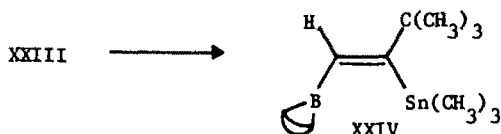
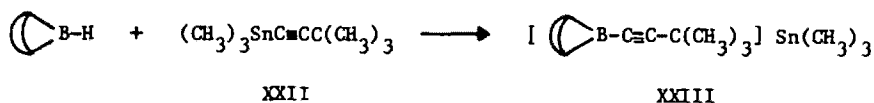

by the corresponding tin or silicon analogs, further reactions occur leading to allenic products.

Pelter and coworkers have been investigating reactions of trialkylalkynylborates with various substrates. They have found that the alkynylborates react with alkylidenemalonates and alkylidene acetoacetates [60]. The reactions are interesting analogs of the rearrangements

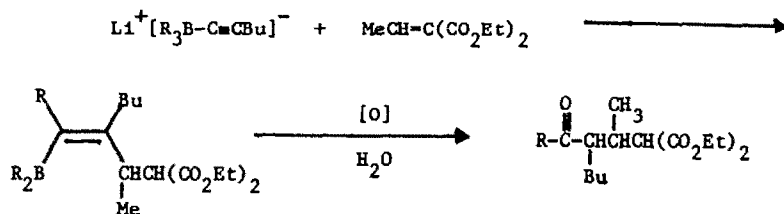

initiated by simple acids such as the protic acids. In a mechanistically related study, they employed benzo-1,3-dithiolium fluoroborate to induce the rearrangement yielding heterocycles which are essentially protected aldehydes [61].

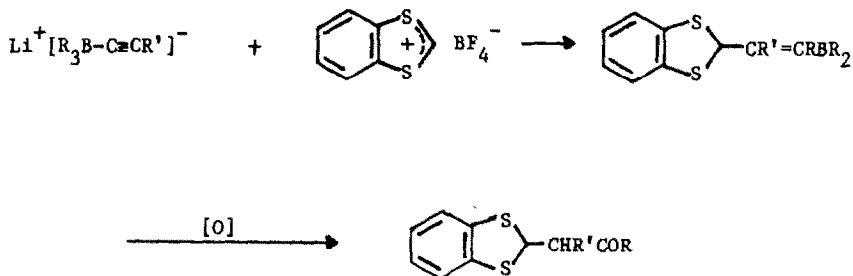

4. Allylboranes

The addition of allylboranes to aldehydes continues to be investigated. The reaction can be used in stereoselective alcohol syntheses. Hoffmann and Zeiss have prepared the (Z)- and (E)-crotylboronates, XXV and XXVI, and reacted them with a number of aldehydes [62]. The homoallylic alcohols are formed with a diastereoselectivity of > 95%.

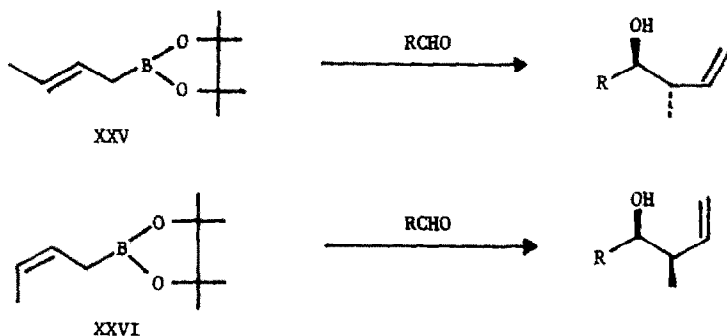

Hoffman and Herold then utilized chiral boronates such as XXVII to produce homoallylic alcohols [63]. The asymmetric induction produces the chiral alcohol in 70% e.e.

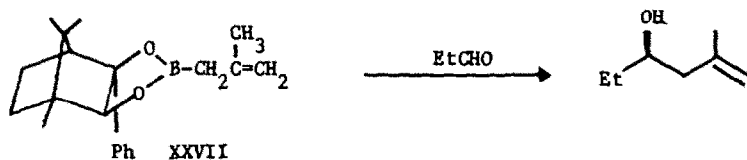

Matteson and Tsai have developed a stereocontrolled synthesis of Z and E terminal dienes via the addition of pinacol (E)-1-trimethylsilyl-1-propene-3-boronate to aldehydes [64].

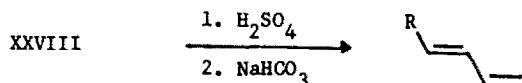
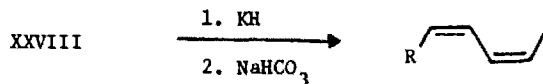
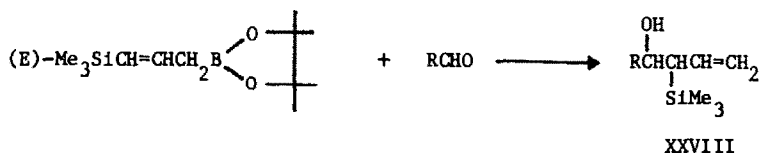

XXIX

Yamamoto, Yatagai, and Muiruyama reacted α -stannyl substituted crotyl 9-BBN reagents with aldehydes in a stereoregulated synthesis of acyclic systems [65]. (M = SiMe₃ or SnMe₃.)

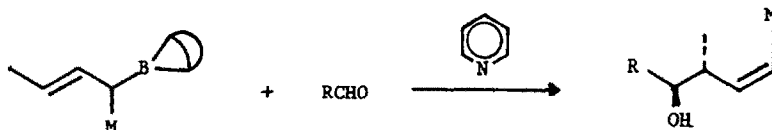

A transition state model is proposed which explains the high stereoselectivity of the reaction.

Mikhailov reports that allylboranes react with silylated alkynes to generate unstable vinylborane intermediates which eliminate boron to form silylated allylacetylenes [66].



Mikhailov also reports that triallylborane will condense with alkenylacetylenes to produce a variety of cyclic and bicyclic heterocycles [67].

5. Enol Borinates

The condensation of boron enolates with a variety of carbonyl compounds is a useful synthetic reaction. Wada reports that boron enolates are readily prepared via the reaction of silyl enol ethers with dialkylboron halides [68].

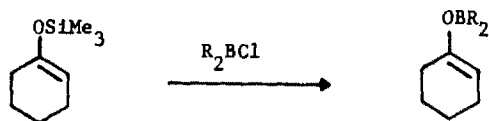

Evans has continued his investigation of the use of boron enolates in stereoselective aldol condensations [69]. A detailed investigation of the enolization of a variety of ketones and carboxylic acid derivatives was conducted. The boron enolates formed from acyclic ketones were found to be dependent on the structure of the ketone, the dialkyl triflate, and the amine used. Consistently good correlation was observed between enolate geometry and the product aldol stereochemistry for acyclic ketones. A mechanism for the enolization involving initial coordination of the boron triflate to the ketone carbonyl with subsequent deprotonation by the amine is proposed to explain the results.

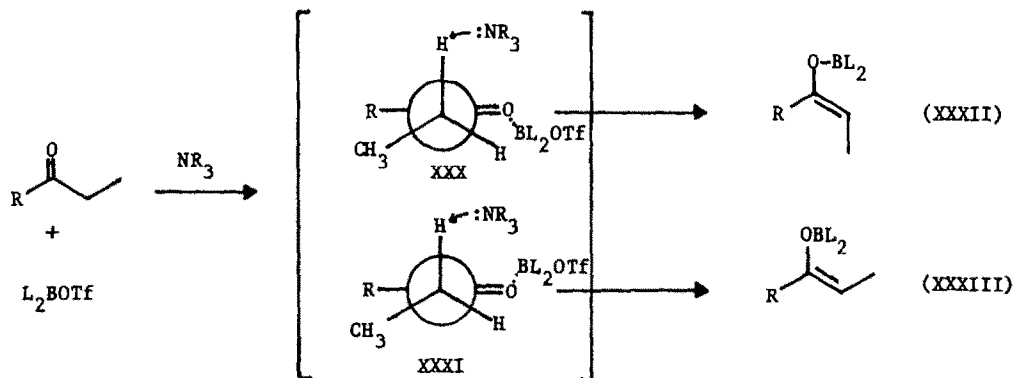

Trans and cis enolates XXXII and XXXIII are derived from deprotonation of syn and anti complexes XXX and XXXI, respectively. Deprotonation tends to be the rate-determining step rather than complexation. All factors being equal ($R_1 = Et$), e.g., XXX = XXXI, anti deprotonation (XXXI \rightarrow XXXIII) is preferred over syn deprotonation (XXX \rightarrow XXXII) with hindered bases. Chiral boron enolates were studied for possible asymmetric induction in the aldol condensation moderate levels of chirality transfer were observed in certain instances.

Evans did achieve high enantioselectivity utilizing enolates derived from β -amino alcohols [70].

The addition of boron enolates to isoquinolinium salts yield isoquinoline derivatives [71].

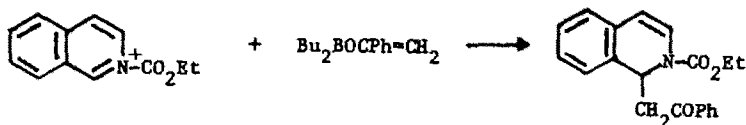

Meyers and Yamamoto utilized boron azoenolates to carry out enantioselective aldol reactions with high three selectivity [72]. The use of boron azaenolate, XXXIV, gave high three selective aldol products in reactions with various aldehydes.

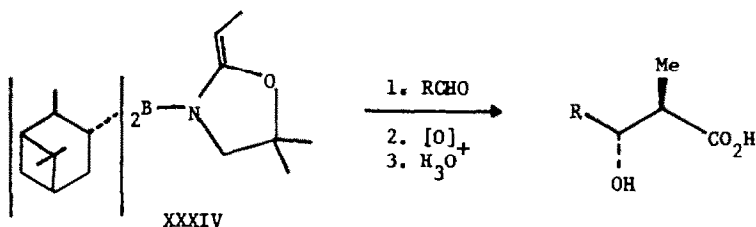

The corresponding erythro aldols could be obtained in moderate enantiomeric excess utilizing the boron azaenolate XXXV.

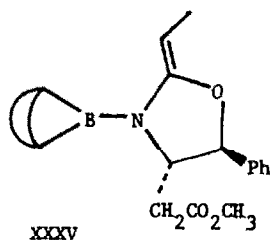

Vinyloxyboranes were reported to react with Schiff bases to yield β-amino acid derivatives [73].

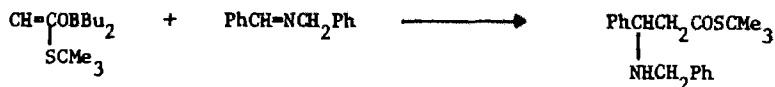

6. Boroadamantanes

Mikhailov and his coworkers continue to explore the adamantane-like boron heterocycles. He has reviewed the formation of boron heterocycles from allylboranes [74]. The boroadamantanes can be prepared via the reaction of propargyl esters with allylboranes. Intermediates from this reaction can be isomerized and hydroborated to yield the 1-boroadamantanes XXXVI [75]. The physical parameters of pyridine and quinoline

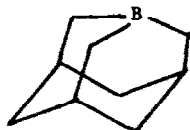

XXXVI

complexes of 1-boraadamantane were studied (bond length, crystal structure, bond angles). The steric effects of the donor heterocycles are not reflected in the boroadamantane bond angles [76].

Mikhailov reports that 1-boroadamantane can be carbonylated to generate adamantylborane derivatives which exhibit appropriate chemistry for alkylboronic esters [77].

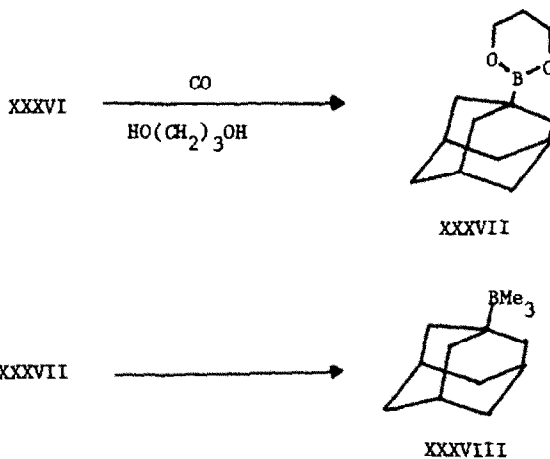

1-Boraadamantane will add to aldehydes and small ketones to generate dimers of XXIX [78].

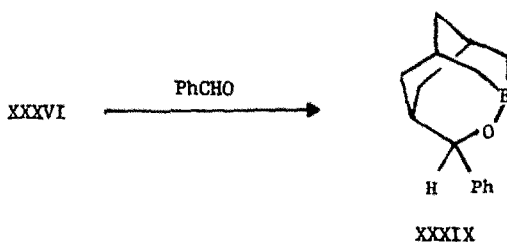

1-Boraadamantane can be aminated by reaction with chloroamines or hydroxylamine-O-sulfonic acid [79].

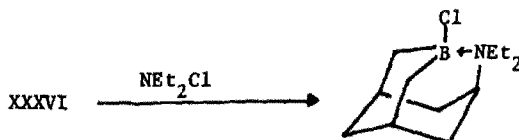

Mikhailov is also studying other boronheterocycles [80,81].

D. CARBON-HETEROATOM BOND FORMATION

1. Group VII

The organoboranes have proven to be versatile synthetic intermedi-

ates not only in carbon-carbon bond formation but in the functionalization of carbon structures. A large number boron-mediated functionalizations have been reported in the past. The oxidation, protonolysis, and halogenation reactions have become routine synthetic transformations. Nevertheless, new reactions continue to appear which are often more selective or are milder than the original reactions. In some instances the new reactions are more suited for specific purposes. Kabalka and his coworkers have developed a number of new organoborane reactions which are designed for the incorporation of isotopes into physiologically active materials. They report that iodine can be readily incorporated into functionally substituted molecules via the reaction of iodine monochloride with organoborane under near neutral conditions at room temperature [82]. The reaction can be applied to the synthesis of vinyl

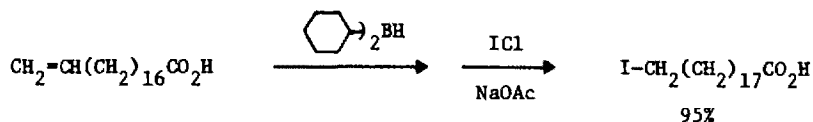

iodides via the reaction of the corresponding vinylboronic acid [83].

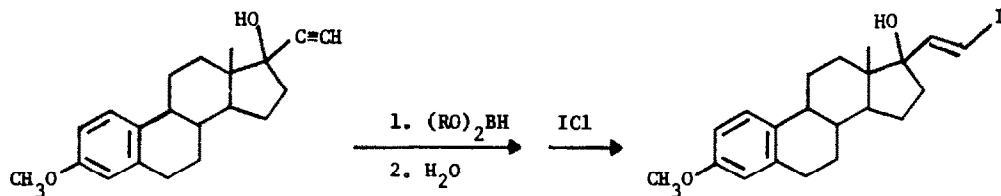

Kabalka and Gooch reported that the reaction can be carried out even more conveniently via the in-situ generation of iodine monochloride [84]. The reaction tolerates a variety of sensitive functional groups and produces high isolated yields of isomerically pure products. The new methods are ideal for incorporating radioiodine in radiopharmaceuti-

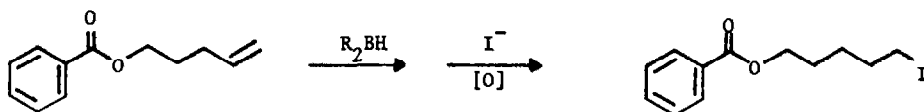

cals and other physiologically active agents since they utilize radioiodide ion essentially quantitatively. [Iodine radioisotopes are obtained most readily in the iodide form.] They have successfully radiolabeled a series of fatty acids and other materials on a no-carrier-added scale [85,86].

Kabalka and his coworkers have extended the reaction to the incorporation of bromine via reaction of bromide ion with organoboranes in the presence of mild oxidizing agents [87].

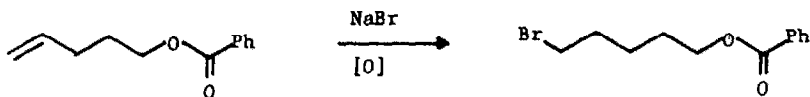

K. Smith and his coworkers have developed a new synthesis of alkyl chlorides via the free radical reaction of trialkylboranes with N,N-dichlorourethane or dichloramine-T [88].

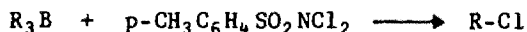

2. Group V

Kabalka and his coworkers developed a new synthesis of amines utilizing the in-situ preparation of chloramine. The reaction involves the sequential addition of ammonium hydroxide and sodium hypochlorite to organoboranes [89].

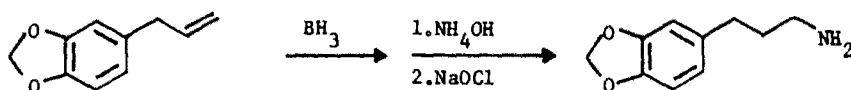

Suzuki and Akimoto have prepared a series of ethyl N-alkylcarbamates utilizing substituted carbamate derivative [90].

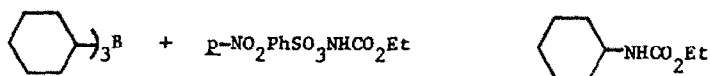

E. HYDROBORATION-OXIDATION/PROTONOLYSIS

1. Natural Products

Hydroboration-oxidation has become a routine procedure for the synthesis of alcohols. The sequence was applied to the synthesis of a number of natural products. White and Burton synthesized (\pm)-cinna-modial from XLI which was obtained via the hydroboration-oxidation of XL [91].

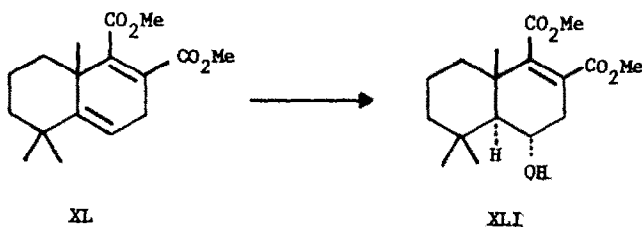

Yatagai and Tokahashi carried out the in-situ hydroboration ($\text{BF}_3 \cdot \text{OEt}_2 / \text{LiAlH}_4$) of abietic acid to yield a mixture of isomerized and monohydroborated products [92]. Ghosh and Ghotak hydroborated the unsaturated acid, XLII to generate the oxoacid XLIII after oxidation [93].

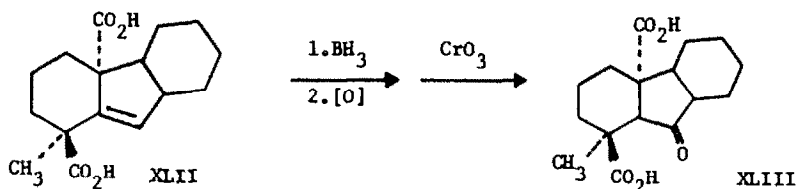

Midland and Kwan report that the hydroboration of Z-ethylidene steroids with 9-BBN generates the 17- β -alkyl steroids [94].

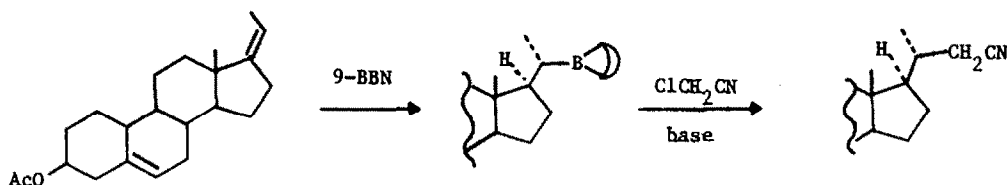

A hydroboration-protonolysis sequence was utilized in the preparation of 1- ^{13}C -oleic acid from the corresponding acetylene [95].

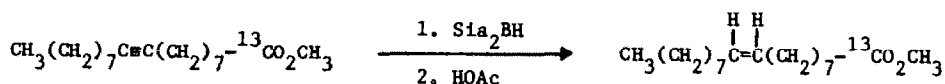

2. General Synthetic Applications

Bloodworth and Eggelte prepared 3-cyclopentenyl hydroperoxide via a hydroboration autooxidation of cyclopentadiene [96].

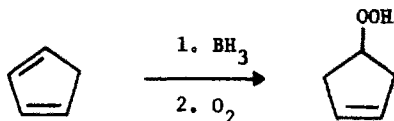

Zweifel and Miller prepared a series of acylsilanes via the hydroboration-oxidation of silylacetylenes [97].

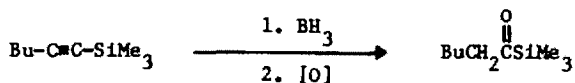

Whiteley developed an interesting new procedure for synthesizing alkyl-9BBN derivatives involving dialkylcuprates [98]. The method can be used to prepare methyl and phenyl derivatives in good yields (>80% isolated).

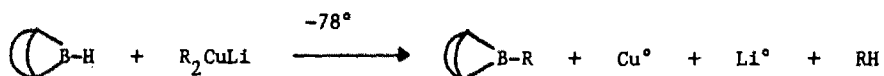

REFERENCES

1. A. Pelter, R. Rosser and S. Mills *J. Chem. Soc., Chem. Commun.*, (1981) 1014-15
2. M. Baboulene, J. L. Torregrosa, V. Speziale, A. Lattes, *Bull. Soc. Chim. Fr.*, 11-12 (1981) 565-70
3. H. C. Brown and P. K. Jadhav, *J. Org. Chem.*, 46 (1981) 5047-5048
4. H. C. Brown, P. K. Jadhav, and A. K. Mandal, *Tetrahedron*, 37 (1981) 3547-3587
5. H. J. Bestmann, K. Suehs, and T. Roeder, *Angew. Chem.*, 93 (1981) 1098-1100
6. J. A. Soderquist and H. C. Brown, *J. Org. Chem.*, 46 (1981) 4599-4600
7. H. C. Brown and J. C. Chen, *J. Org. Chem.*, 46 (1981) 3978-3988
8. P. K. Jadhav and H. C. Brown, *J. Org. Chem.*, 46 (1981) 2988-2990
9. H. C. Brown, S. U. Kulkarni, *J. Organomet. Chem.*, 218 (1981) 299-307
10. P. J. Maddocks, A. Pelter, K. Rowe, K. Smith, and C. Subrahmanyam, *J. Chem. Soc., Perkin Trans. 1*, (1981) 653-656
11. R. Contreras and B. Wrackmeyer, *J. Organomet. Chem.*, 205 (1981) 15-19
12. L. Synoradzki, M. Boleslawski, S. Pasynkiewicz, and T. Zawada, *Przem. Chem.*, 60 (1981) 2000-2002
13. H. C. Brown, Y. M. Choi, and S. Narasimhan, *Synthesis*, (1981) 605-606
14. H. C. Brown, S. Narasimhan, and Y. M. Choi, *Synthesis* (1981) 996-997
15. M. F. Grundon, D. G. McCleery and J. W. Wilson, *Chem. Soc.; Perkin Trans. 1*, (1981) 231-235
16. A. Hirao, S. Itsuno, S. Nakahama, and N. Yamazaki, *J. Chem. Soc., Chem. Commun.*, (1981) 315-317
17. B. E. Maryanoff, D. F. McComsey, and S. O. Nortey, *J. Org. Chem.*, 46 (1981) 355-360.

18. G. W. Kabalka and S. T. Summers, *J. Org. Chem.*, 46 (1981) 1217-1218
19. H. Mokhtar and M. Zaidelwicz, *Pol. J. Chem.*, 55 (1981) 757-761.
20. M. M. Midland and P. E. Lee, *J. Org. Chem.*, 46 (1981) 3933-3934
21. M. M. Midland and N. H. Nguyen, *J. Org. Chem.*, 46 (1981) 4107-4108
22. W. S. Johnson, B. Frei, and A. S. Gopalan, *J. Org. Chem.*, 46 (1981) 1512-1513
23. H. C. Brown, J. L. Hubbard, and B. Singaram, *Tetrahedron*, 37 (1981) 2359-2362
24. H. C. Brown, B. Singaram, and P. C. Mathew, *J. Org. Chem.*, 46 (1981) 2712-2717
25. H. C. Brown, B. Singaram, and P. C. Mathew, *J. Org. Chem.*, 46 (1981) 4541-4544
26. M. A. Makhlof and B. Rickborn, *J. Org. Chem.*, 46 (1981) 4810-4811
27. H. Toi, Y. Yamamoto, A. Sonoda, and A. Murahashi, *Tetrahedron*, 37 (1981) 2261-2267
28. D. J. Raber, W. C. Guida, and D. G. Shoenberger, *Tetrahedron Lett.*, 22 (1981) 5107-5110
29. J. L. Duncan, D. C. McKean, I. Torto, and G. D. Nivellini, *J. Mol. Spectrosc.*, 85 (1981) 16-39
30. E. Hamilton and J. L. Duncan, *J. Mol. Spectrosc.*, 90 (1981) 517-530
31. B. C. Ramsey and L. M. Isabelle, *J. Org. Chem.*, 46 (1981) 179-182
32. F. Davidson and J. W. Wilson, *Org. Mass. Spectrum.*, 16 (1981) 467-468
33. N. M. D. Brown, F. Davidson, and J. W. Wilson, *J. Organomet. Chem.*, 210 (1981) 1-8
34. R. Huschens, R. Rensch, and H. Friebolin, *Chem. Ber.*, 114 (1981) 3581-3588
35. M. E. Gurskii, A. S. Shashkov, and B. M. Mikhailov, *Izv. Akad. Nauk SSSR, Ser. Khim.*, (1981) 341-352
36. M. E. Gurskii and B. M. Mikhailov, *Izv. Akad. Nauk SSSR, Ser. Khim.*, (1981) 394-398
37. A. J. Zozulin, H. J. Jakobsen, T. F. Moore, A. R. Garber, and J. D. Odem, *J. Magn. Reson.*, 41 (1980) 458-466
38. R. Goetze, H. Noeth, H. S. Pommerening, D. Sedlak, and B. Wrackmeyer, *Chem. Ber.*, 114 (1981) 1884-1893
39. S. M. Van der Kerk, *J. Organomet. Chem.*, 215 (1981) 315-323
40. U. Henricksen, J. P. Snyder, and T. A. Halgren, *J. Org. Chem.*, 46 (1981) 3767-3768
41. G. D. Graham, S. C. Freilich, and W. N. Lipscomb, *J. Am. Chem. Soc.*, 103 (1981) 2546-2552

42. H. C. Brown and G. G. Pai, *J. Org. Chem.*, 46 (1981) 4713-4716
43. H. C. Brown, U. S. Racherla, and H. Taniguchi, *J. Org. Chem.*, 46 (1981) 4313-4314
44. H. C. Brown and T. M. Ford, *J. Org. Chem.*, 46 (1981) 647-648
45. C. F. Reichert, W. E. Pye, and T. A. Bryson, *Tetrahedron*, 37 (1981) 2441-2444
46. R. H. Prager, *Aust. J. Chem.*, 34 (1981) 143-150
47. A. J. Prieto and G. L. Larson, *Synth. Commun.*, 10 (1981) 675-684
48. M. E. Garst and J. N. Bonfiglio, *Tetrahedron Lett.*, 22 (1981) 2075-2076
49. A. Pelter and M. J. Rao, *J. Chem. Soc., Chem. Commun.*, (1981) 1149-1150
50. H. C. Brown and J. B. Campbell, Jr., *Aldrichimica Acta*, 14 (1981) 3-11
51. H. C. Brown, *Org. Synth.: Today Tomorrow, Proc. 3rd IUPAC Symp. Org. Synth.*, 1980 (1981) 121-137
52. G. Zweifel and N. R. Pearson, *J. Org. Chem.*, 46 (1981) 829-830
53. B. Singaram, G. A. Molander, and H. C. Brown, *Heterocycles*, 15 (1981) 231-236
54. H. C. Brown and G. A. Molander, *J. Org. Chem.*, 46 (1981) 645-647
55. N. Miyaoura, H. Sugimoto, and A. Suzuki, *Tetrahedron Lett.* 22 (1981) 127-130
56. S. W. Slayden, *J. Org. Chem.*, 46 (1981) 2311-2314
57. H. J. Bestman and K. Li, *Tetrahedron Lett.*, 22 (1981) 4941-4944
58. C. Bihlmayer and B. Wrackmeyer, *Z. Naturforsch. B: Anorg. Chem., Org. Chem.*, 36B (1981) 1265-1269
59. B. Wrackmeyer and C. Bihlmayer, *J. Chem. Soc., Chem. Commun.* (1981) 1093-1094
60. A. Pelter and R. J. Madhusudhana, *Tetrahedron Lett.*, 22 (1981) 797-800
61. A. Pelter, P. Rupani, and P. Stewart, *J. Chem. Soc., Chem. Commun.*, (1981) 164-165
62. R. W. Hoffmann and H.-J. Zeiss, *J. Org. Chem.*, 46 (1981) 1309-1314
63. R. W. Hoffmann and T. Herold, *Chem. Ber.*, 114 (1981) 375-383
64. D. J. Tsai and D. S. Matteson, *Tetrahedron Lett.*, 22 (1981) 2751-2752
65. Y. Yamamoto, H. Yatagai, and K. Muruyama, *J. Am. Chem. Soc.*, 103 (1981) 3229-3231
66. S. F. Ponomarev, Y. N. Bubnov, and B. M. Mikhailov, *Izv. Akad. Nauk SSSR, Ser. Khim.*, (1981) 1859-1861

67. B. M. Mikhailov, Y. N. Bubnov, and S. I. Frolov, *Izv. Akad. Nauk SSSR, Ser. Khim.*, (1981) 2114-2119
68. M. Wada, *Chem. Lett.*, (1981) 153-156
69. D. A. Evans, J. V. Nelson, E. Vogel, and T. R. Taber, *J. Am. Chem. Soc.*, 103 (1981) 3099-3111
70. D. A. Evans, J. M. Takacs, L. R. McGee, M. D. Ennis, D. J. Mathre, and J. Bartroli, *Pure Appl. Chem.*, 53 (1981) 1109-1127
71. K. Akiba, K. Araki, M. Nakatani, and M. Wada, *Tetrahedron Lett.*, 22 (1981) 4961-4964
72. A. I. Meyers and Y. Yamamoto, *J. Am. Chem. Soc.*, 103 (1981) 4278-4279
73. M. Otsuka, M. Yoshida, S. Kobayashi, M. Ohno, Y. Umezawa, and H. Morishima, *Tetrahedron Lett.*, 22 (1981) 2109-2112
74. B. M. Mikhailov, *Sov. Sci. Rev. Soc. B*, 2 (1981) 283-355
75. B. M. Mikhailov and T. K. Baryshnikova, *J. Organomet. Chem.*, 219 (1981) 295-300
76. L. G. Vorontsova, O. S. Chizhov, V. N. Smirnov, and B. M. Mikhailov, *Izv. Akad. Nauk SSSR, Ser. Khim.*, (1981) 595-600
77. T. A. Shchegoleva, E. M. Shashkova, and B. M. Mikhailov, *Izv. Akad. Nauk SSSR, Ser. Khim.*, (1981) 1098-1104
78. B. M. Mikhailov, T. K. Baryshnikova, and A. S. Shashkov, *J. Organomet. Chem.*, 219 (1981) 301-308
79. B. M. Mikhailov, E. A. Shagova, and M. Y. Etinger, *J. Organomet. Chem.*, 220 (1981) 1-9
80. V. A. Dorokhov, L. I. Lavrinovich, A. S. Shashkov, and B. M. Mikhailov, *Izv. Akad. Nauk SSSR, Ser. Khim.*, (1981) 1371-1373
81. V. A. Dorokhov, B. M. Zolotarev, and B. M. Mikhailov, *Izv. Akad. Nauk SSSR, Ser. Khim.*, (1981) 869-874
82. E. E. Gooch and G. W. Kabalka, *Synth. Commun.*, 11 (1981) 521-525
83. G. W. Kabalka, E. E. Gooch, and H. C. Hsu, *Syn. Commun.*, 11 (1981) 247-251
84. G. W. Kabalka and E. E. Gooch, *J. Org. Chem.*, 46 (1981) 2582-2584
85. G. W. Kabalka and E. E. Gooch, *J. Chem. Soc., Chem. Commun.*, (1981) 1011
86. G. W. Kabalka, E. E. Gooch, and C. Otto, *J. Radional. Chem.*, 65 (1981) 115-121
87. G. W. Kabalka, K. A. R. Sastry, H. C. Hsu, and M. D. Hylarides, *J. Org. Chem.*, 46 (1981) 3113-3115
88. V. B. Jigajinni, W. E. Paget, and K. Smith, *J. Chem. Res. Synop.* (1981) 376-377.
89. G. W. Kabalka, K. A. R. Sastry, G. W. McCollum, and H. Yoshioka, *J. Org. Chem.*, 46 (1981) 4296-4298

90. I. Akimoto and A. Suzuki, *Synth. Commun.*, 11 (1981) 475-480
91. L. P. J. Burton, and J. D. White, *J. Am. Chem. Soc.*, 103 (1981) 3226-3228
92. M. Yatagai and T. Takahashi, *Mokuzai Gakkaishi*, 27 (1981) 649-653
93. S. Ghosh and U. R. Ghatak, *J. Org. Chem.*, 46 (1981) 1486-1490
94. M. M. Midland and Y. C. Kwon, *J. Org. Chem.*, 46 (1981) 229
95. T. W. Whaley, G. H. Daub, R. D. Walker, and D. L. Williams, *J. Labelled Compd. and Radiopharm.*, 18 (1981) 1593-1603.
96. A. J. Bloodworth and H. J. Eggelte, *Tetrahedron Lett.*, 21 (1980) 2001-2004
97. J. A. Miller and G. Zweifel, *Synthesis*, (1981) 288-289
98. C. G. Whitley, *J. Chem. Soc., Chem. Commun.* (1981) 5-6