

## WCl<sub>6</sub>/LiAlH<sub>4</sub> PROMOTED TRANSFORMATION OF IMINES INTO SECONDARY AND TERTIARY AMINES

TAKAO IKARIYA \*, YASUTOSHI ISHIKAWA, KIYOMIKI HIRAI, and SADA O YOSHIKAWA

*Department of Synthetic Chemistry, Faculty of Engineering, University of Tokyo, Hongo, Bunkyo-ku, Tokyo, 113 (Japan)*

(Received December 13th, 1984)

### Summary

The reaction of WCl<sub>6</sub>/LiAlH<sub>4</sub> with imines, R'N=CHR, gave tertiary amines, R'N(CH<sub>2</sub>R)<sub>2</sub>, and secondary amines, R'NHCHRCH<sub>2</sub>R. Isotope labeling experiments revealed that the reaction involved two types of azatungstenacyclobutanes, WNR'CHRCHR and WCHRNR'CHR, produced from the reaction of an alkylidene tungsten intermediate with the imine C=N double bond. Formation of these metal-lacyclobutanes is highly dependent on the solvent used.

### Introduction

The mechanism of olefin metathesis has been extensively investigated and now it is generally accepted that the reaction proceeds by a stepwise mechanism involving alternating alkylidenemetal and metallacyclobutane intermediates [1]. On the other hand, the proposed intermediates, alkylidenemetals, have been trapped by unsaturated molecules such as olefins [2] and carbonyl compounds [3] to give cyclopropane derivatives and methylene transfer products such as Wittig type products, respectively. Recently Schrock reported that alkylidenetantalum complexes smoothly reacted with imines to provide new alkylimidotantalum complexes and olefins [4]. Furthermore, Hegedus has shown that carbenechromium complexes react under sunlight with imines to produce β-lactams in good yields, where an azachromiacyclobutane intermediate is suggested [5].

These results suggest that some catalytic systems could promote a transformation reaction of imines similar to olefin metathesis into olefins and azo compounds or some other nitrogen-containing compounds. In this regard we wish to report herein that the reaction of the WCl<sub>6</sub>/LiAlH<sub>4</sub> system, with imines **1a–1f** produces tertiary

\* Author to whom correspondence should be addressed.

amines **2a–2f** and secondary amines **3a–3f** after hydrolysis, where azatungstenacyclobutanes may be involved as possible intermediates.

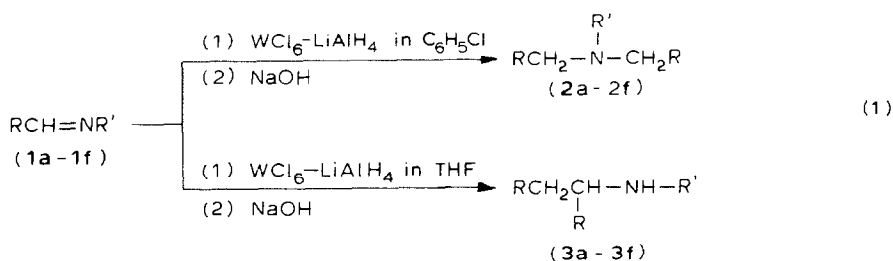

## Results and discussion

The  $\text{WCl}_6/\text{LiAlH}_4$  system, which is known to exhibit high catalytic activity for olefin metathesis and promotes reductive coupling reactions of carbonyl compounds providing olefins [6], has been found to promote a reaction of imines as shown in eq. 1. The combination of  $\text{WCl}_6$  and  $\text{LiAlH}_4$  is required for formation of amines after hydrolysis and the optimum molar ratio:  $\text{WCl}_6/\text{LiAlH}_4/\text{imine}$  is 1/1/4. The representative results obtained from the reaction of  $\text{WCl}_6/\text{LiAlH}_4$  with imines are shown in Table 1. Although the reaction did not occur catalytically it was found that the reaction products were significantly dependent upon the solvent used. In chlorobenzene benzaldehyde N-substituted imines **1a–1c** produced the tertiary amines **2a–2c** as main products in good yields. However imine **1d** which has a bulkier substituent on nitrogen provided secondary amine **3d** as the main product even in chlorobenzene with a trace amount of tertiary amine **2d**. On the other hand, in THF secondary amine **3a** or **3b** is produced as a main product in a poor yield with contamination of a hydrogenated product,  $\text{R}'\text{NHCH}_2\text{Ph}$  [7].

In order to clarify the reaction mechanism a reaction with  $\text{LiAlD}_4$  was carried out. When  $\text{LiAlD}_4$  was used in place of  $\text{LiAlH}_4$  the reaction of **1a** in chlorobenzene gave

TABLE 1  
REACTION OF  $\text{WCl}_6/\text{LiAlH}_4$  WITH IMINES

Imine (RCH=NR') (1)	Solvent	Product (%) <sup>a</sup>	
		$\text{RCH}_2\overset{\text{R}'}{\text{N}}\text{CH}_2\text{R}$ (2)	$\text{RCH}_2\underset{\text{R}}{\text{CH}}\text{NHR}'$ (3)
PhCH=NEt ( <b>1a</b> )	C <sub>6</sub> H <sub>5</sub> Cl	53	–
PhCH=N-n-Bu ( <b>1b</b> )	C <sub>6</sub> H <sub>5</sub> Cl	67	–
PhCH=NPh ( <b>1c</b> )	C <sub>6</sub> H <sub>5</sub> Cl	69	–
PhCH=N-t-Bu ( <b>1d</b> )	C <sub>6</sub> H <sub>5</sub> Cl	trace	5
(CH <sub>3</sub> ) <sub>2</sub> CHCH=N-n-Bu ( <b>1e</b> )	C <sub>6</sub> H <sub>5</sub> Cl	39	–
PhCH=NEt ( <b>1a</b> )	THF	–	10
PhCH=N-n-Bu ( <b>1b</b> )	THF	–	7
p-MeC <sub>6</sub> H <sub>4</sub> CH=N-n-Bu ( <b>1f</b> )	THF	–	12

<sup>a</sup> GLC yield based on  $\text{WCl}_6$ .

**2a-d<sub>2</sub>**, (PhCHD)<sub>2</sub>NEt (eq. 2), which was identified by its NMR and mass spectra. Furthermore, evidence that another intermediate is involved in the same reaction in THF was provided by isolation of PhCHDCHPhNH(D)Et from the reaction of imine **1a** with WCl<sub>6</sub>/LiAlD<sub>4</sub> in THF (eq. 3). These results seem to indicate that as

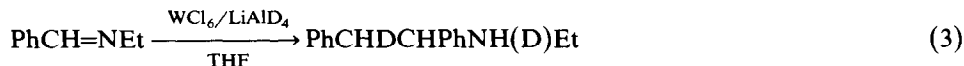
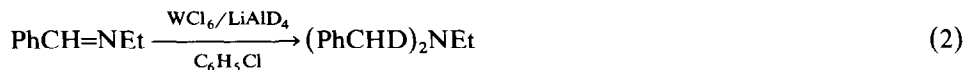

shown in Scheme 1 the reaction proceeds through an azatungstenacyclobutane

SCHEME 1

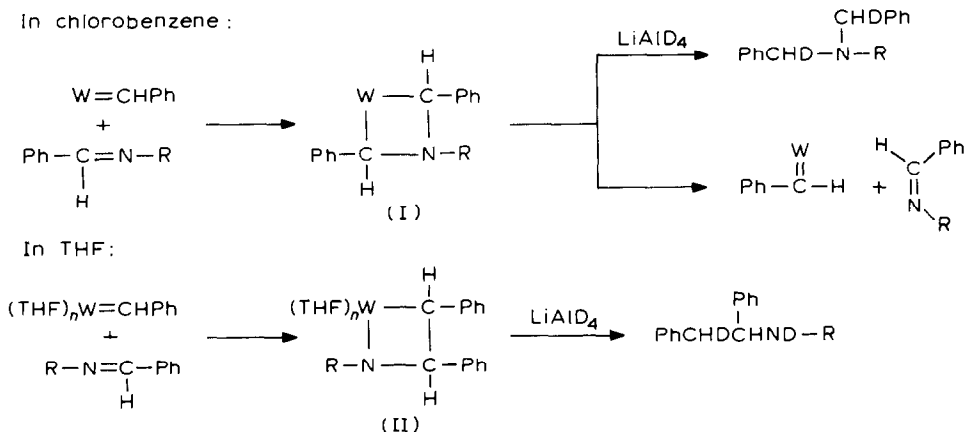

intermediate such as I or II, which might be generated from attack of imine on alkydene metal in a similar fashion to the olefin metathesis reaction [1]. Subsequent hydrogenolysis of these metallocyclobutanes with LiAlH<sub>4</sub> (LiAlD<sub>4</sub>) gave the corresponding amines.

Alternatively, it would be possible that the hydrogenated product, PhCH<sub>2</sub>NHEt, adds to the starting imine followed by deamination to provide the tertiary amine. A similar mechanism has appeared in RuCl<sub>2</sub>(PPh<sub>3</sub>)<sub>3</sub> catalyzed secondary and tertiary amine formation reactions from primary amines [8]. This alternative pathway can be ruled out in view of the result that the addition of PhCH<sub>2</sub>NHEt to the reaction mixture of WCl<sub>6</sub>/LiAlH<sub>4</sub>/imine in chlorobenzene did not increase the formation of a tertiary amine.

Generally, the M=C double bond in alkydidenemetal complexes should be polarized depending upon several factors such as the oxidation state of the metal and the electronic property of the ligand including oxo and halide ligands as shown in eq. 4 [1b,9].



Our results obtained here can be explained in terms of a change in polarization of the M=C double bond caused by coordination of solvent and steric interaction in an azametallacyclobutane. In chlorobenzene the imine nitrogen should add to the electrophilic carbene carbon as in the Fischer-type alkydene complexes **4b**, while in THF the alkydidenetungsten complex coordinated by THF might be attacked in the

opposite direction like the Schrock-type alkylidene complexes **4a** [4]. The facts that imine **1d** gave the secondary amine as the main product even in chlorobenzene and that the reactivity of **1d** or **1e** became low can be explained by the steric effect in the azatungstenacyclobutane intermediate.

Furthermore, as can be seen in Fig. 1 it was found that upon addition of  $\text{PPh}_3$  to the reaction mixture the formation of a secondary amine was observed even in chlorobenzene with decreasing amount of a tertiary amine. The maximum yield of the secondary amine was obtained upon addition of one equivalent of  $\text{PPh}_3$ . Since the  $\text{PPh}_3$  ligand could coordinate to the central metal, the azatungstenacyclobutane containing  $\text{PPh}_3$  would be a more favorable intermediate as reaction intermediate II in THF.

In our reaction system  $\text{WCl}_6$  alone is not reactive for the transformation of imines, and addition of  $\text{LiAlH}_4$  causes the reaction, suggesting that  $\text{WCl}_6$  is reduced by  $\text{LiAlH}_4$  to some lower valent tungsten species which would react with imine to give an alkylidene complex. Although an attempt to trap the alkylidenemetal complex failed, it is reasonable to assume that this reaction would involve an alkylidenemetal intermediate in view of the fact that iminium salts react with low-valent tungsten carbonyl complexes,  $\text{M}_2\text{W}(\text{CO})_5$  ( $\text{M} = \text{Na}$  and  $\text{Li}$ ), to produce the alkylidene complex,  $(\text{CO})_5\text{W}=\text{CPh}_2$  [10], and moreover that an alkylidenetungsten has been shown to be involved in the reaction of  $\text{WCl}_6/\text{LiAlH}_4$  with carbonyl compounds [6]. An attempt to isolate an azatungstenacyclobutane complex containing THF or a phosphine ligand from our reaction system is currently under investigation.

## Experimental

All manipulations were carried out under nitrogen. Imines were prepared according to the reported methods [11]. Other starting materials were of commercial grade. THF and chlorobenzene were dried by the usual method and distilled under nitrogen.  $\text{WCl}_6$  was purified by sublimation. The MS spectrum was recorded on a Hitachi M-80 instrument.

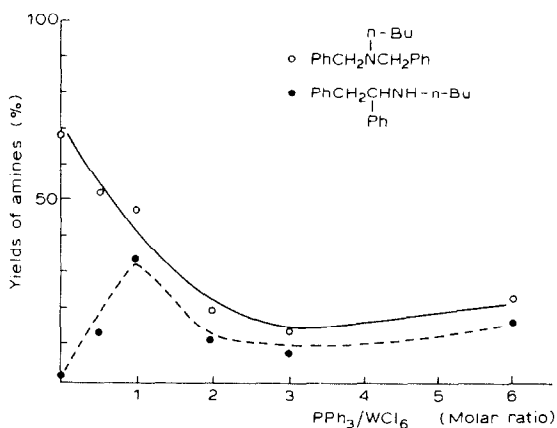

Fig. 1. Yields of tertiary and secondary amines from reaction of  $\text{WCl}_6/\text{LiAlH}_4$  with  $\text{PhCH}=\text{N}-n\text{-Bu}$  in chlorobenzene as a function of the molar ratio of added  $\text{PPh}_3$  to  $\text{WCl}_6$ .

#### *Reaction of $WCl_6$ - $LiAlH_4$ with imines*

The general procedure was as follows:  $WCl_6$  (0.5 mmol) was added to 30 ml of chlorobenzene cooled to  $-55^\circ\text{C}$ , followed by addition of  $LiAlH_4$  (0.5 mmol) and then imine (2.0 mmol). Reaction took place smoothly to give a deep red solution. The reaction mixture was then warmed to room temperature and further stirred for 5 h. The reaction was quenched with 20% aqueous NaOH and organic products were extracted with ether. The yields were determined by GLC using an internal standard (stilbene), and are summarized in Table 1.

#### *Reaction of $WCl_6$ - $LiAlD_4$ with imine 1a*

The reaction was carried out in a similar manner to that described above using  $LiAlD_4$  instead of  $LiAlH_4$ . After the usual work up, the reaction products were isolated by GLC and identified by NMR and mass spectroscopy. Mass spectra for  $(\text{PhCHD})_2\text{NEt}$  ( $m/e$ , rel int.): 227 ( $M^+$ , 79); 212(100); 92(99), for  $\text{PhCHDCHPhNH(D)Et}$ : 227 ( $M^+$ , 7); 212(25); 134(5); 92(100).

#### *Effect of addition of $PPh_3$ on the reaction of $WCl_6$ / $LiAlH_4$ with imines*

To a chlorobenzene solution of  $PPh_3$  were added  $WCl_6$  (0.5 mmol) and  $LiAlH_4$  (0.5 mmol) at  $-50^\circ\text{C}$ . Imine **1b** was then added dropwise. The reaction mixture was stirred for 20 h at room temperature. After the same work up as described above the product yields were determined by GLC using an internal standard. The results are shown in Fig. 1.

#### **Acknowledgment**

This work was partly supported by a Grant-in-Aid for Scientific Research from the Ministry of Education, Science and Culture, Japan (58750680).

#### **References**

- 1 For recent reviews on metathesis reaction, see: (a) N. Calderon, J.P. Lawrence, and E.A. Ofstead, *Adv. Organomet. Chem.*, 17 (1979) 449; (b) R.H. Grubbs, *Prog. Inorg. Chem.*, 24 (1978) 1; (c) T.J. Katz, *Adv. Organomet. Chem.*, 16 (1977) 28.
- 2 (a) P.G. Gassman and T.H. Johnson, *J. Am. Chem. Soc.*, 98 (1976) 6058, 6059; (b) R. Noyori, H. Kawaguchi, and H. Takaya, *Tetrahedron Lett.*, (1974) 1749; (c) M. Brookhart, J.R. Tucker, and G.R. Husk, *J. Am. Chem. Soc.*, 103 (1981) 979; (d) K.A.M. Kremer, P. Helquist, and R.C. Kerber, *ibid.*, 103 (1981) 1862; (e) M.P. Doyle, J.H. Bagheri, and R.L. Dorow, *Organometallics*, 3 (1984) 53.
- 3 (a) S.H. Pine, R. Zahler, D.A. Evans, and R.H. Grubbs *J. Am. Chem. Soc.*, 102 (1980) 3270; (b) F.W. Hartner, Jr. and J. Schwarz, *ibid.*, 103 (1981) 4979.
- 4 S.M. Rocklage and R.R. Schrock, *J. Am. Chem. Soc.*, 104 (1982) 3077.
- 5 (a) M.A. McGuire and L.S. Hegedus, *J. Am. Chem. Soc.*, 104 (1982) 5538; (b) L.S. Hegedus, M.A. McGuire, L.M. Schultze, C. Yijun and O.P. Anderson, *ibid.*, 106 (1984) 2680.
- 6 Y. Fujiwara, R. Ishikawa, F. Akiyama, and S. Teranishi, *J. Org. Chem.*, 43 (1978) 2477.
- 7 Under our reaction conditions imines did not undergo hydrogenation by  $LiAlH_4$  in chlorobenzene but in THF imines **1c** and **1f** were easily hydrogenated even at room temperature.
- 8 (a) B.T. Khai, C. Conclio, and G. Porzi, *J. Organomet. Chem.*, 208 (1981) 249; (b) B.T. Khai, C. Conclio, and G. Porzi, *J. Org. Chem.*, 46 (1981) 1759; (c) C.W. Jung, J.D. Fellman, and P.E. Garrou, *Organometallics*, 2 (1983) 1042.
- 9 C.P. Casey and H.E. Tuinstra, *J. Am. Chem. Soc.*, 100 (1978) 2270.
- 10 R.P. Beatty, J.M. Maher, and N.J. Cooper, *J. Am. Chem. Soc.*, 103 (1981) 238.
- 11 S.R. Sandler and W. Karo, *Organic Functional Group Preparation*, 2 (1971) 246.