

TRANSITION METALS IN ORGANIC SYNTHESIS  
ANNUAL SURVEY COVERING THE YEAR 1984 \*

Louis S. Hegedus

Department of Chemistry, Colorado State University, Fort Collins, CO 80523, USA

CONTENTS

I. General Comments	209
II. Carbon-Carbon Bond Forming Reactions	209
A. Alkylations	209
1. Alkylation of Organic Halides Tosylates, Acetates, and Epoxides	209
2. Alkylation of Acid Derivatives	227
3. Alkylation of Olefins	229
4. Decomposition of Diazoalkanes and Other Cyclopropanations	245
5. Cycloaddition Reactions	250
6. Alkylation of Alkynes	255
7. Alkylation of Allyl and Propargyl Alcohols and Acetates	260
8. Coupling Reactions	275
9. Alkylation of $\pi$ -Allyl Complexes	282
10. Alkylation of Carbonyl Compounds	284
11. Alkylation of Aromatic Compounds	296
12. Alkylation of Dienyl and Diene Complexes	301
13. Metal/Carbene - Reactions	307
B. Conjugate Addition	313
C. Acylation Reactions (Excluding Hydroformylation)	323
1. Carbonylation of Alkenes and Alkynes	323
2. Carbonylation of Halides	338
3. Carbonylation of Nitrogen Compounds	342
4. Carbonylation of Oxygen Compounds	345
5. Miscellaneous Carbonylations	348
6. Decarbonylation Reactions	348
7. Reactions of Carbon Dioxide	349

---

\*Previous review see J.Organomet.Chem., 283(1985)1-219.

D. Oligomerization	351
E. Rearrangements	363
1. Metathesis	363
2. Olefin Isomerization	365
3. Rearrangements of Allylic and Propargylic Oxygen and Nitrogen Compounds	365
4. Skeletal Rearrangements	370
5. Miscellaneous Rearrangements	371
III. Functional Group Preparations	371
A. Halides	371
B. Amides, Nitriles	373
C. Amines, Alcohols	376
D. Ethers, Esters, Acids	383
E. Heterocycles	390
F. Alkenes, Alkanes	406
G. Ketones, Aldehydes	410
H. Organosilanes	416
I. Miscellaneous	417
IV. Reviews	421

## I. General Comments

This annual survey covers the literature for 1984 dealing with the use of transition metal intermediates for organic synthetic transformations. It is not a comprehensive review but is limited to reports of discrete systems that lead to at least moderate yields of organic compounds, or that allow unique organic transformations, even if low yields are obtained. Catalytic reactions that lead cleanly to a major product and do not involve extreme conditions are also included. This is not a critical review, but rather a listing of the papers published in the title area.

The papers in this survey are grouped primarily by reaction type rather than by organometallic reagent, since the reader is likely to be more interested in the organic transformation effected than the metal causing it. Oxidation, reduction, and hydroformylation reactions are specifically excluded, and will be covered in a different annual survey. Also excluded are structural and mechanistic studies of organometallic systems unless they present data useful for synthetic application. Finally, reports from the patent literature have not been surveyed since patents are rarely sufficiently detailed to allow reproduction of the reported results.

## II. Carbon-Carbon Bond-Forming Reactions

### A. Alkylations

#### 1. Alkylation of Organic Halides, Tosylates, Acetates, and Epoxides

"Carbon-carbon bond formation involving organic halides and transition metal complexes" was the subject of a chapter in a book (360 references) [1]. "Applications of organocopper(I) compounds in organic synthesis" has been reviewed (27 references) [2]. "Mixed organocuprates containing new classes of non-transferable ligands" was the topic of a dissertation [3]. Copper-assisted nucleophilic substitution of aryl halogens has been reviewed (189 references) [4]. Active copper metal, made by reduction of copper(I) iodide with lithium naphthalenide, combined with organic halides to form alkyl cuprates which underwent typical organocopper reactions (equation 1) [5]. A detailed nmr study of the reagent  $R_2Cu(CN)Li_2$  showed that a rapid dissociation-reassociation was involved, and that the reagent had different states of aggregation in THF and in ether [6]. The reagent  $[R_2CuCN]Li_2$  efficiently alkylated 2° halides and highly substituted epoxides (equations 2 and 3) [7]. Copper-catalyzed nucleophilic aromatic substitution was claimed to proceed as in equation 4, and not be involve free radicals [8]. Iron(II) salts catalyzed the alkylation of aryl halides by ketone enolates (equations 4 and 5) [9].

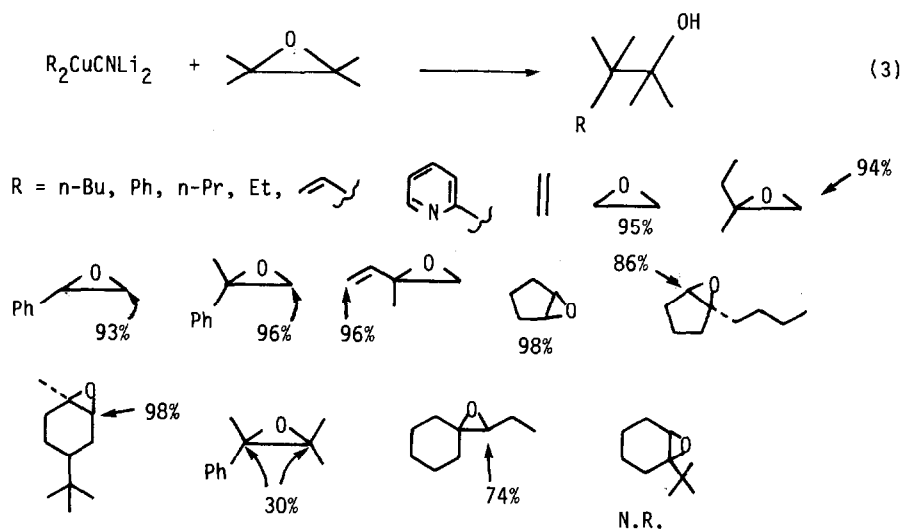
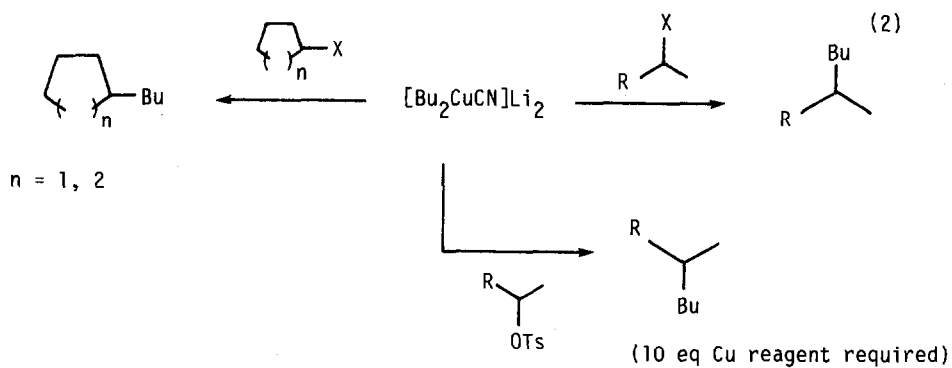
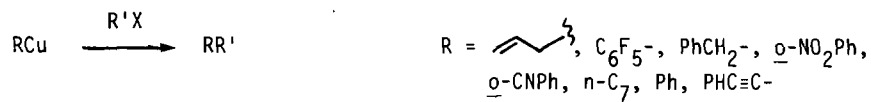
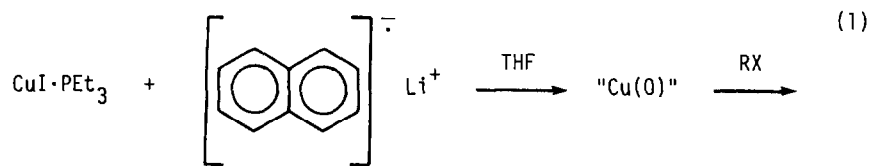

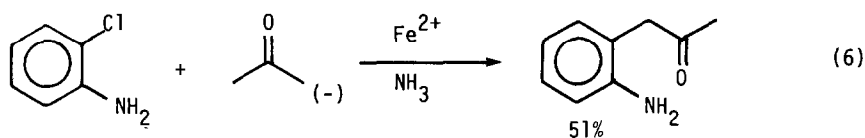
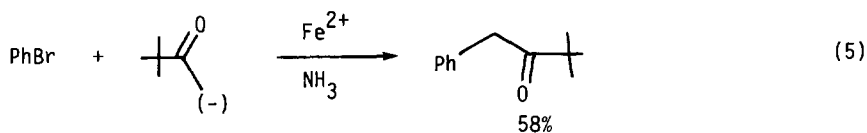
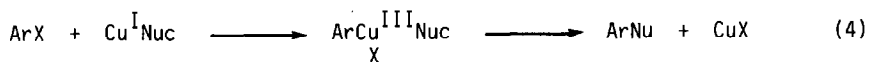

*o*-Bromophenyl allyl ethers underwent alkylation by organocopper reagents to give mixtures of open chain and cyclic compounds (equation 7) [10]. The mixed cuprates of lithiated amidines underwent facile alkylation by a number of halides (equation 8) [11]. Cyclopropylmethyl halides underwent alkylation by organocuprates to give both cyclic and acyclic products [12]. The ratio depended on the nature of the alkyl group and the halide (equation 9) [13].

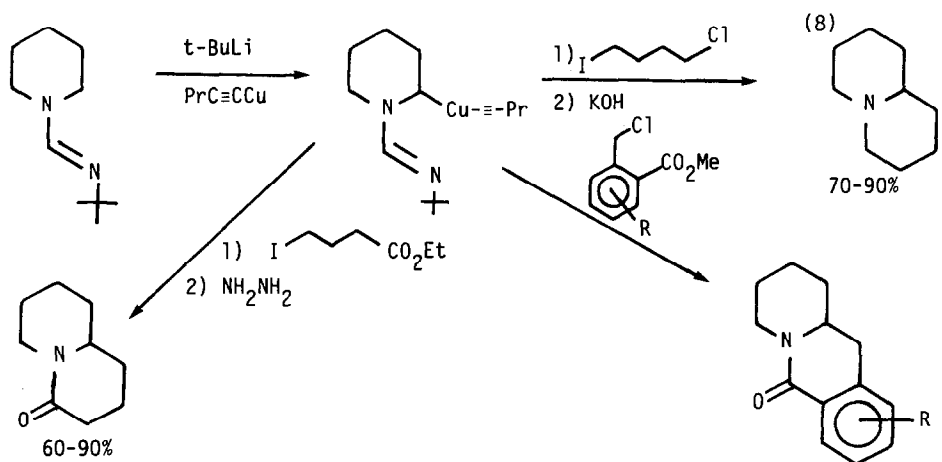
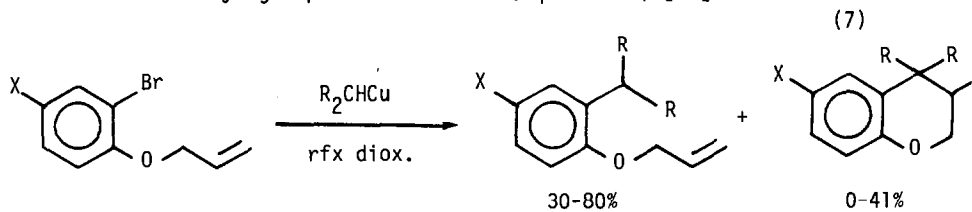

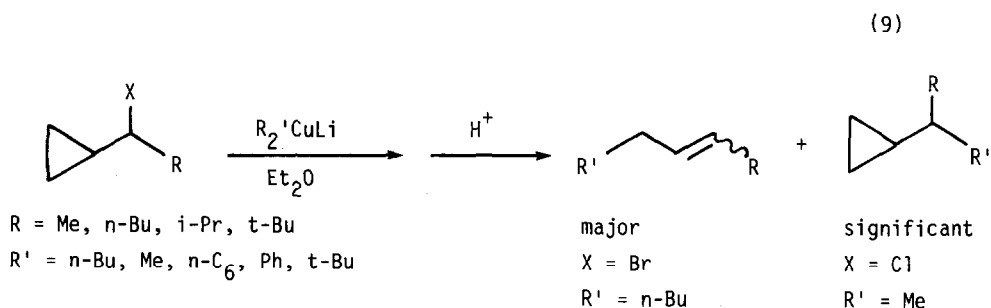

Organocuprates alkylated  $\gamma$ -halo- $\alpha$ -aminoesters without racemization (equation 10) [14].  $\beta$ -Halo- $\alpha$ -aminoesters behaved similarly although elimination became competitive (equation 11) [15]. Allenic bromides were alkylated by organocuprates in an  $S_N2'$  process with high anti selectivity (equation 12) [16]. Chiral allenic bromides were alkylated by organozinc reagents and palladium(0) catalysts with clean inversion (equation 13) [17].

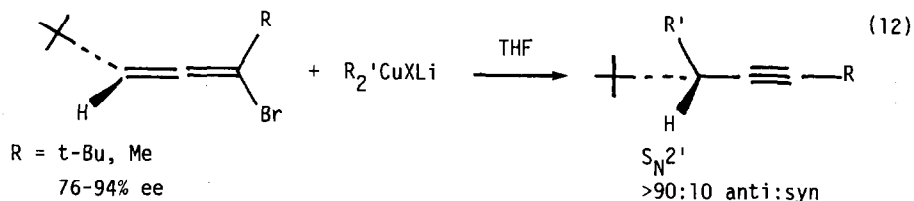
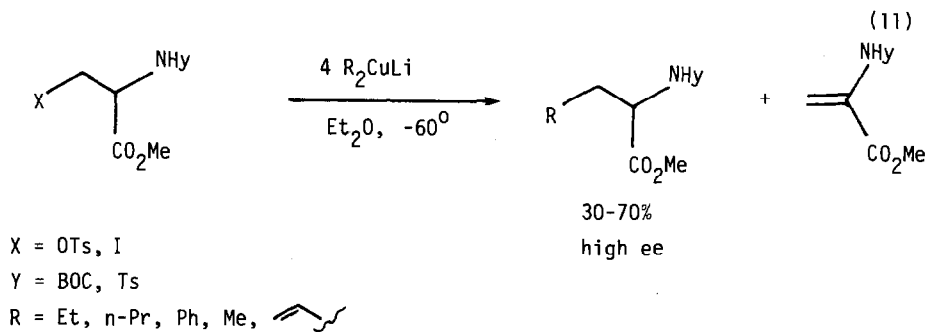
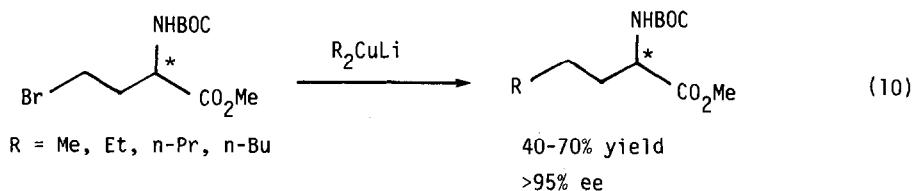

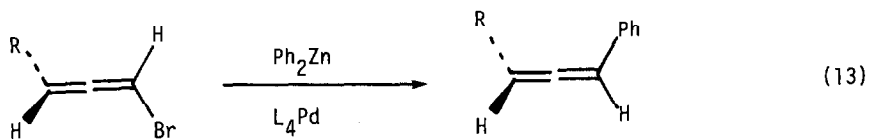

Copper(I) salts catalyzed the alkylation of tosylates (equation 14) and halides by acetal-containing Grignard reagents [18]. Copper(I) catalyzed reactions of organolithium and Grignard reagents has been reviewed (89 references) [19]. Nickel(II) salts catalyzed the polyalkylation (equation 15) [20] and monoalkylation (equation 16) [21] of polyhaloarenes. Nickel(II) salts also catalyzed the replacement of aromatic thio groups by Grignard reagents (equation 17) [22]. This topic was the subject of a dissertation [23].

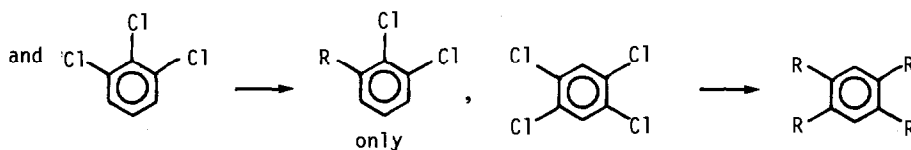
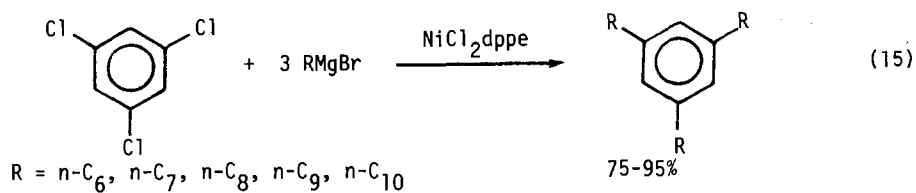
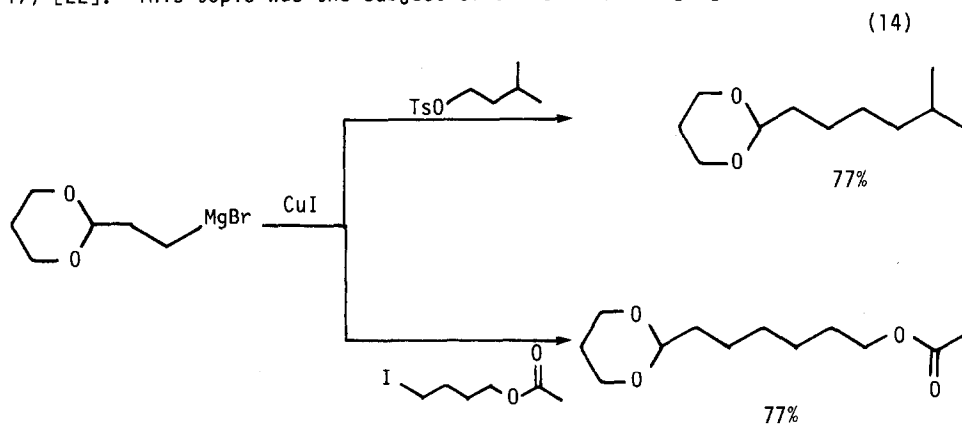

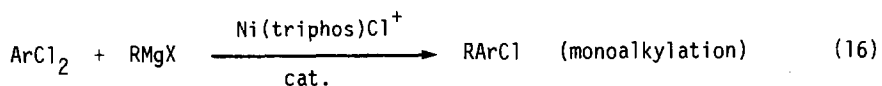

1,2; 1,3; 1,4

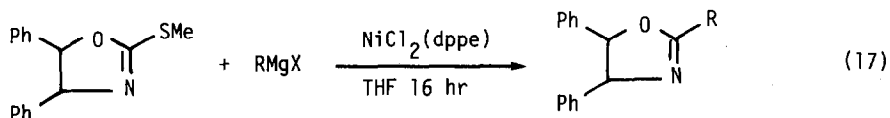

76-90%

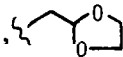
R = Ph, Et, n-Bu, ptol, 

Palladium(II) catalysts were most effective for the cross coupling of secondary Grignard reagents with halides (equation 18) [24]. Chirality (with low ee) was induced into the alkylation of vinyl halides by secondary Grignards using chiral nickel catalysts (equation 19) [25]. However chiral ferrocenyl phosphine nickel complexes remain the reagent of choice for this process. Copper(I) salts catalyzed the reaction of Grignard reagents with epoxides (equation 20) [26]. This chemistry was used in the synthesis of talaromycin B (equation 21) [27]. The stereochemistry of epoxide ring opening depended on the age of the Grignard reagent (equation 22) [28].

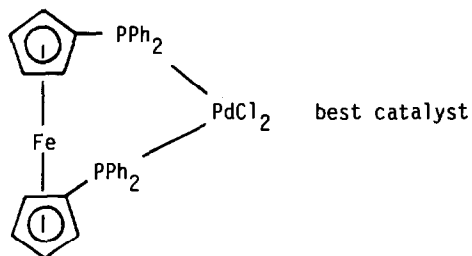
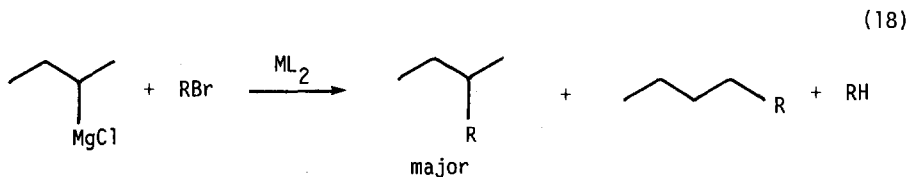



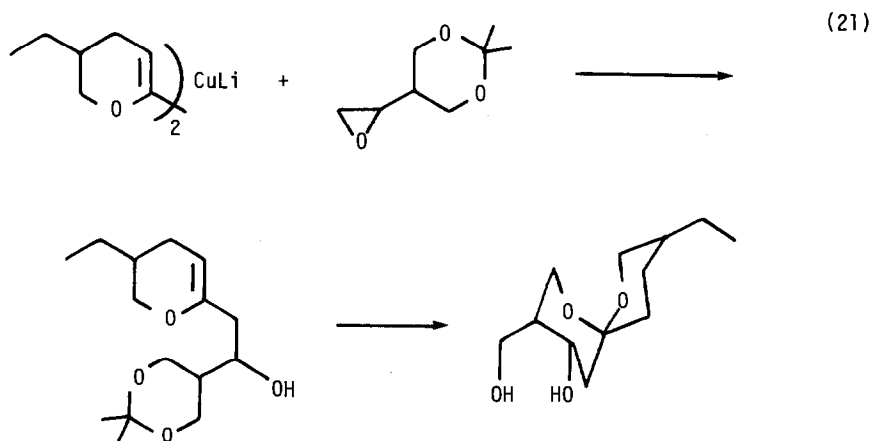
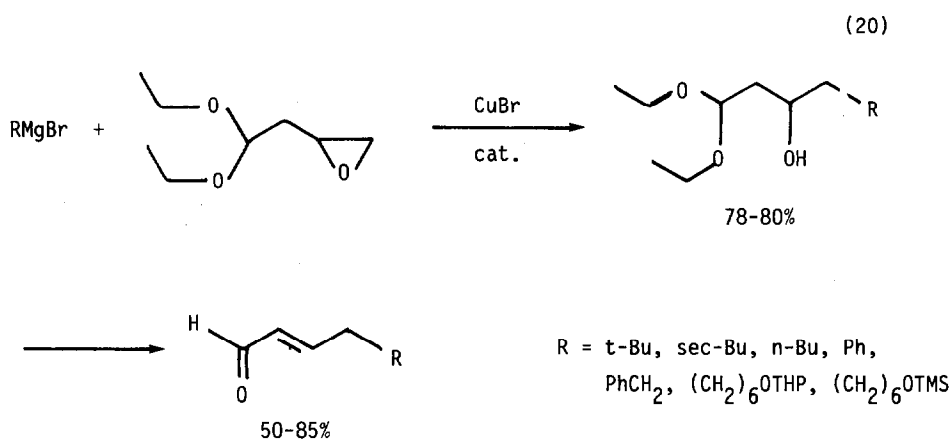
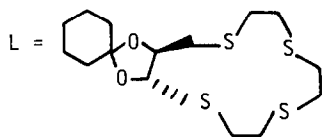
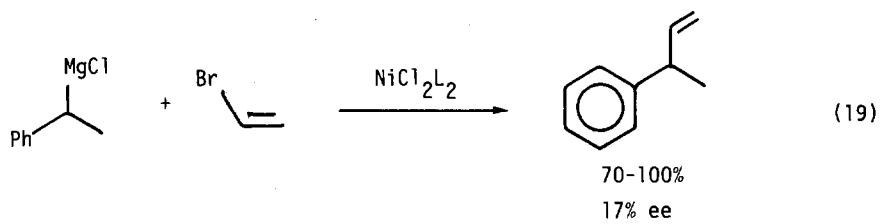

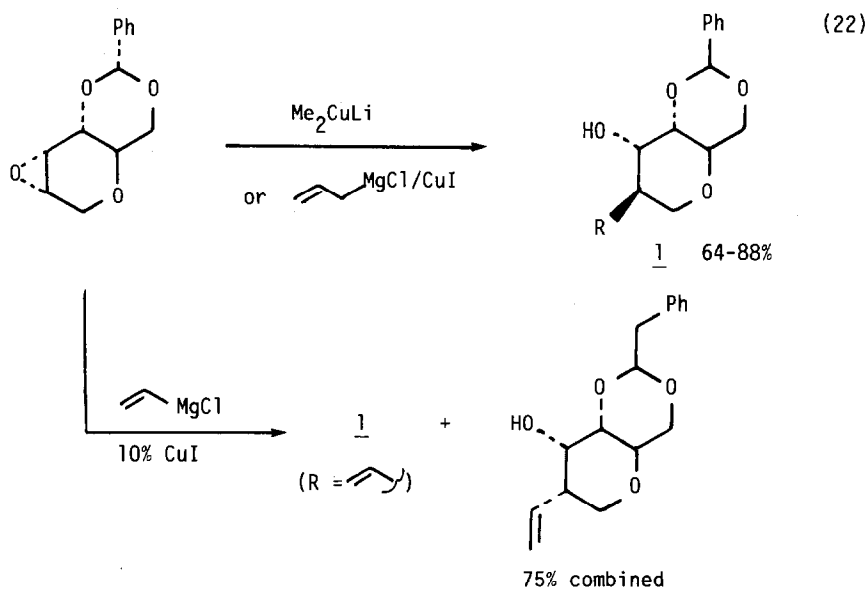

Transmetalation processes are becoming increasingly important in organic synthesis. Transfer of organic groups from boron to palladium has been used in several transformations. Heteroaromatic boranes were arylated by aryl halides using palladium(0) catalysts (equation 23) [29][30]. Unsymmetrical biaryls were synthesized by the palladium(0) catalyzed coupling of aryl halides with aryl borates (equation 24) [31]. Conjugated dienes were prepared by a similar process (equation 25) [32]. Vinyl boranes were alkylated by halides using copper(II) catalysts (equation 26) [33]. Halothiophenes were coupled to thiopheneboronic acids using palladium(0) catalysts (equation 27) [34] [35]. Phosphorous compounds could also be arylated by a similar process (equation 28) [36], (equation 29) [37].

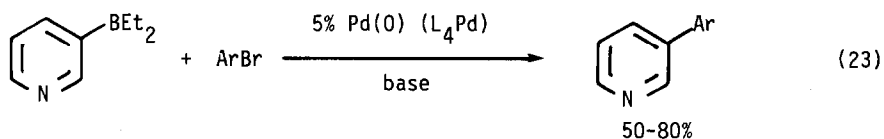

Ar = 2-MePh, 4-MePh, 2-MeOPh, 4-MeOPh, 2-NO<sub>2</sub>Ph, 4-NO<sub>2</sub>Ph, 2-COMePh, 4-COMePh, 4-ClPh, 2-CO<sub>2</sub>MePh, 4-CO<sub>2</sub>Me, 2-NHCOPh

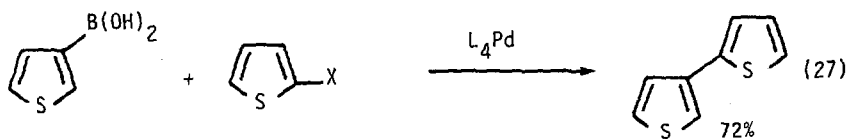
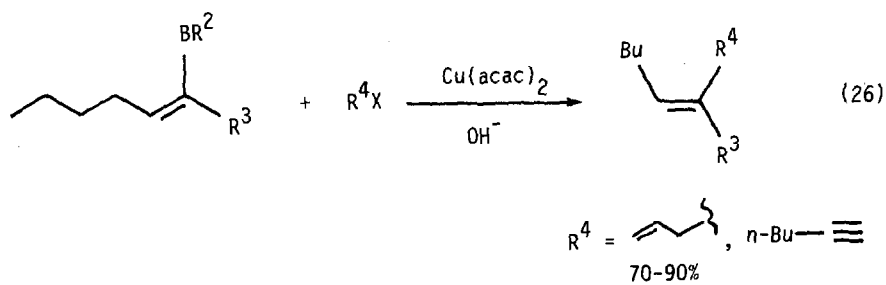
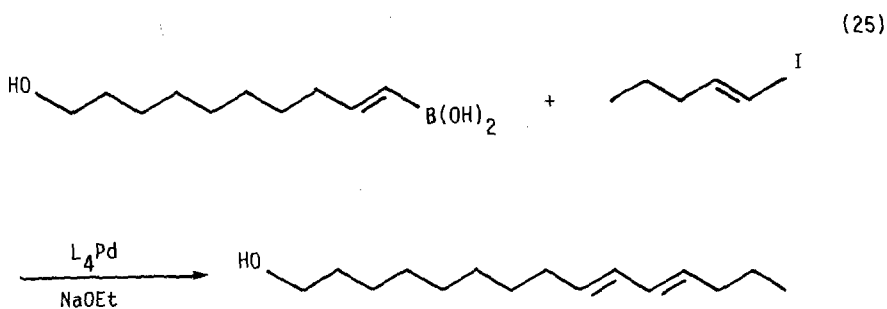
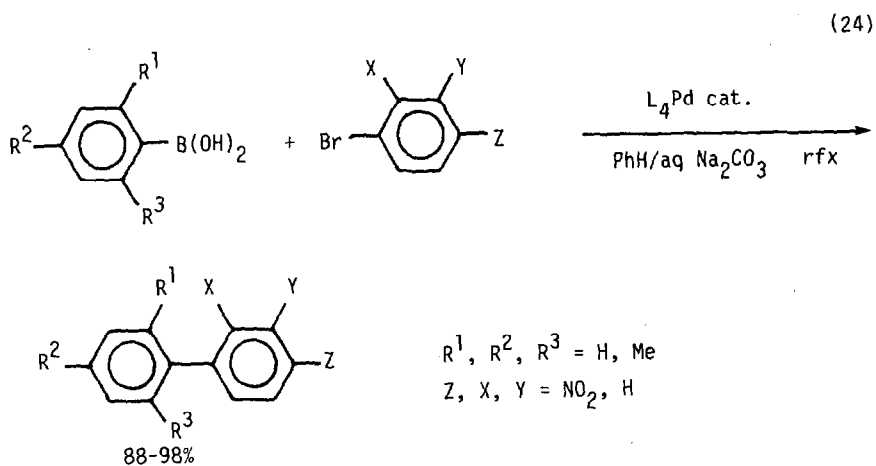

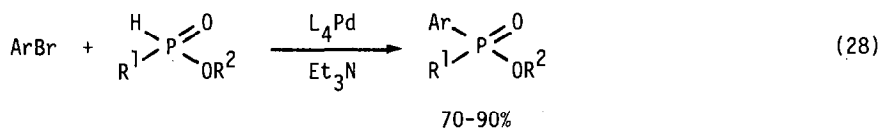

Ar = Ph, p-tol, o-tol, 4-ClPh, 4-MeOPh, 4-PhPh, 4-MeCOPh, 4-Me<sub>2</sub>NPh, 4-CNPh, β-Naph, 2-thienyl, 4-NO<sub>2</sub>Ph

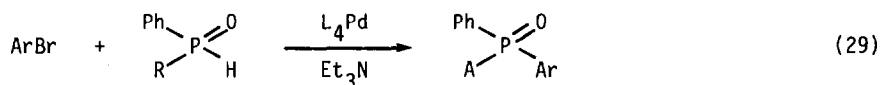

Tin-to-palladium transmetalation has also been extensively developed. Benzyl methyl ethers were synthesized by the alkylation of aryl halides by methoxymethyltin reagents catalyzed by palladium complexes (equation 30) [38]. Benzyl cyanides were made by a similar process (equation 31) [39]. α-Haloketones were alkylated by tin enolates, in the presence of palladium catalysts (equation 32) [40]. Aryl halides were similarly alkylated by tin enolates (equation 33) (equation 34) [41]. Allyl halides were alkylated by vinyl tin (equation 35) and aryl tin reagents (equation 36) in the presence of palladium catalysts [42]. Palladium and Lewis acid catalyzed cross coupling of allylic with organostannanes was the subject of a dissertation [43].

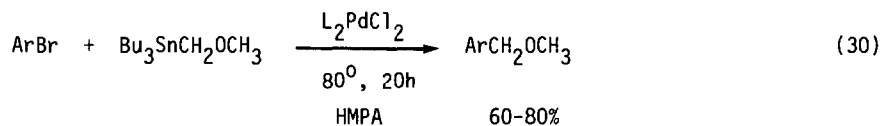

Ar = Ph, o-MePh, m-MePh, p-MePh, p-ClPh, o-ClPh, o-MeOPh, p-AcPh, p-CNPh, p-NO<sub>2</sub>Ph

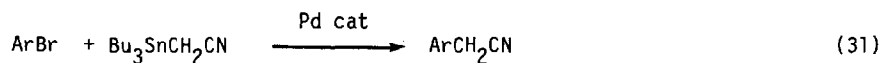

Ar = Ph	o-tol	m-tol	p-tol	o-MeOPh	p-MeOPh	o-ClPh	p-ClPh	
72%	74%	74%	78%	70%	77%	67%	66%	

p-MeCOPh, p-CNPh, p-NO<sub>2</sub>Ph fail

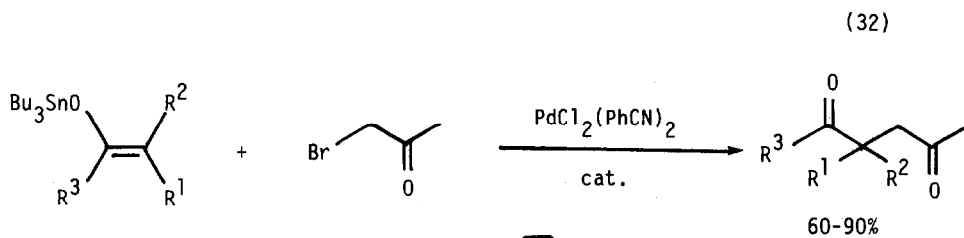

enolate =  $\text{CH}_2\text{COCH}_3$ ,  $\text{CH}_2\text{CO-t-Bu}$ ,  $\text{CH}_2\text{CO-i-Pr}$ ,  $\text{Cyclohex-1-en-1-yl}$ ,  $\text{CH}_2\text{CO}_2\text{-t-Bu}$ ,  
 $\text{CHMeCO-t-Bu}$ ,  $\text{CHMeCOEt}$ ,  $\text{CMe}_2\text{COMe}$ ,  $\text{CH}_2\text{CO-n-C}_6$

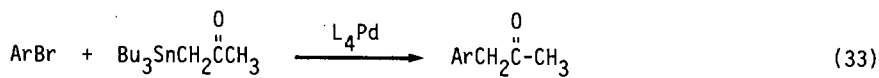

60-90%

Ar = Ph	o-tol	m-tol	p-tol	o-MeOPh	p-MeOPh	ClPh	p-ClPh	
72%	74%	74%	78%	70%	77%	67%	66%	

p-MeCOPh, p-CNPh, p-NO<sub>2</sub>Ph fail

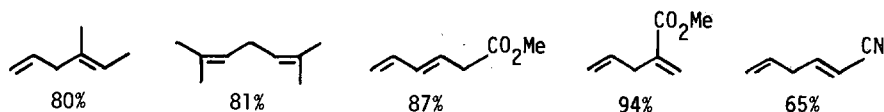
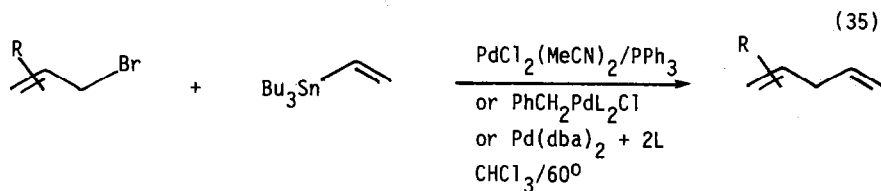
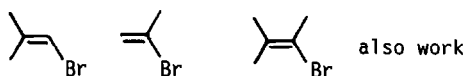
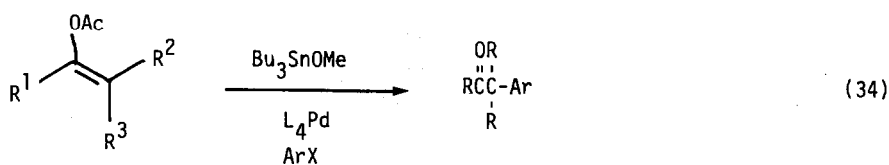

(continued on next page)

(equation 35 continued)

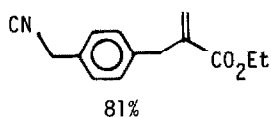
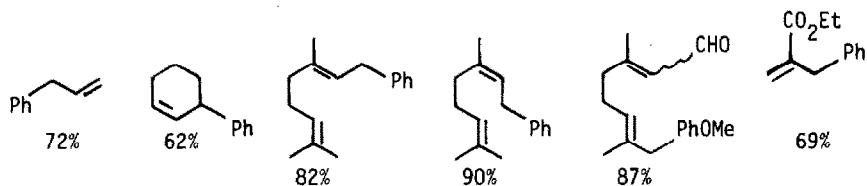
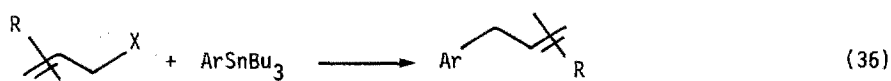
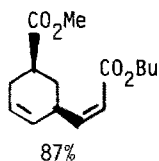
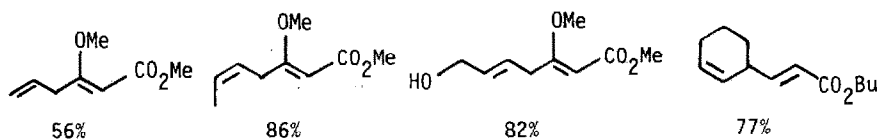

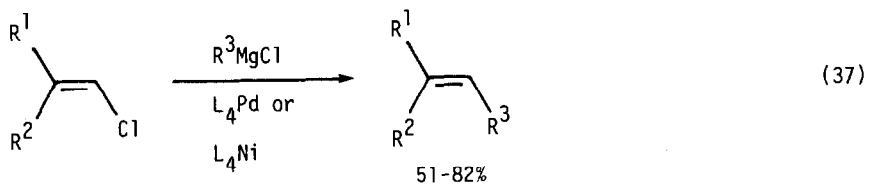

Palladium(0) and nickel(0) complexes catalyzed the alkylation of vinyl chlorides by Grignard reagents (equation 37) [44]. Diynes were prepared by the palladium(0) catalyzed alkylation of vinyl halides by alkynes (equation 38) [45]. Organo zinc reagents alkylated iodouracil derivatives in the presence of palladium(0) catalysts (equation 39) [46]. Malononitrile alkylated aryl halides in the presence of palladium catalysts (equation 40) [47]. Palladium catalysis was also claimed in the synthesis of mitomycins, although the substrates react in a similar manner in the absence of palladium catalysts (equation 41) [48]. Palladium(II) salts catalyzed the coupling of halo-diphenyl systems, probably by aromatic substitution (equation 42) [49]. Acetanilide was orthopalladated, then alkylated by cleavage with reactive halides (equation 43) [50].

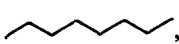

$R^1 = \text{Me, Et, H, } n\text{-C}_8, n\text{-C}_4$

$R^2 = \text{H, Et, Me}$

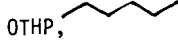
$R^3 =$  , , , 

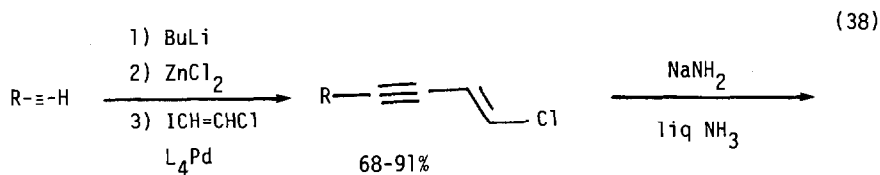

$R\equiv\equiv\equiv H$

$R = n\text{-C}_6, n\text{-C}_5, \text{Ph}$

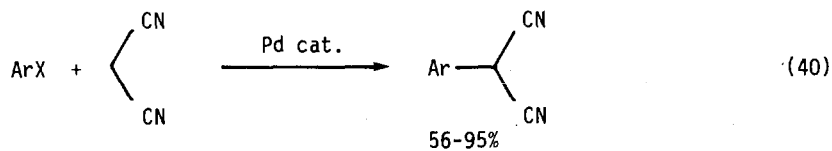
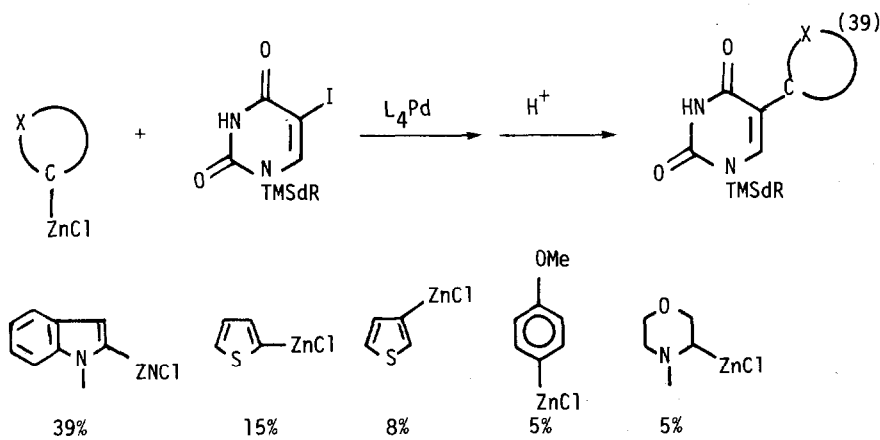

$Ar = \text{Ph, } p\text{-MePh, } o\text{-MePh, } p\text{-MeOPh, } o\text{-MeOPh, } p\text{-ClPh, } p\text{-PhPh}$

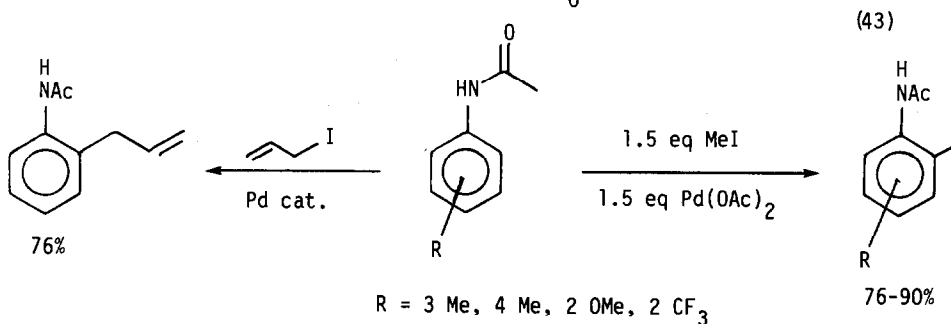
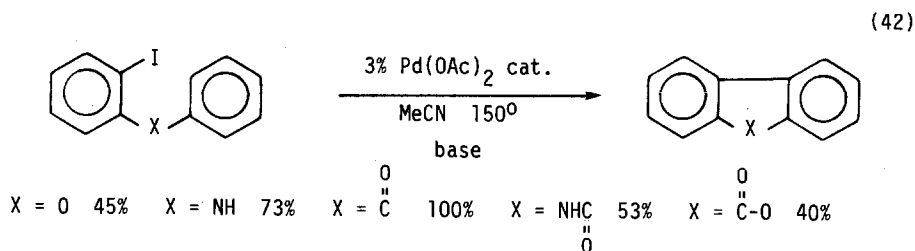
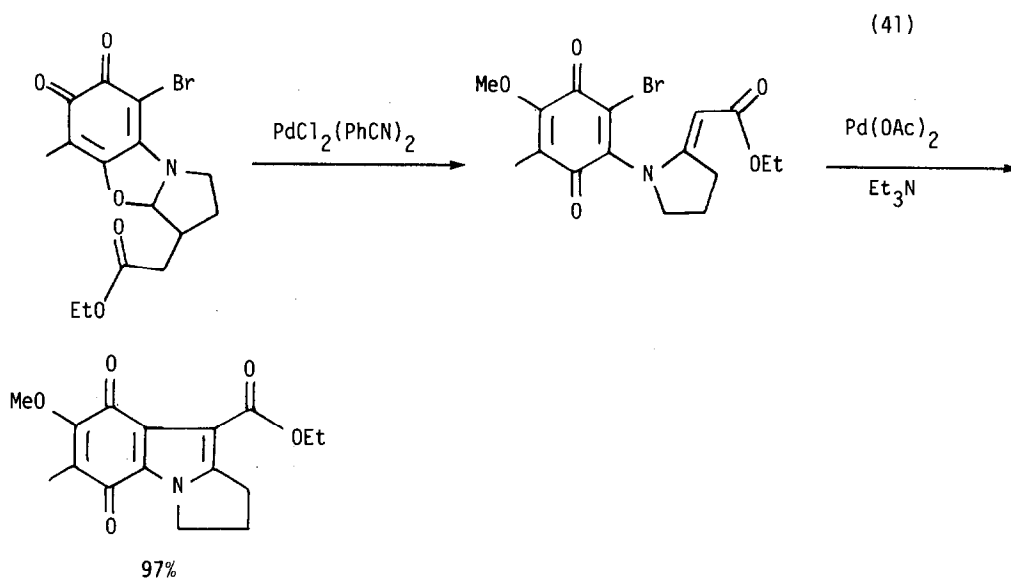

Mixed palladium(0)-copper(I) catalysts were used to alkylate dihaloaryl compounds with alkynes (equation 44) [51]. Polymers were made from bisalkynes (equation 45). Propargyl alcohol was arylated in a similar fashion (equation 46) [52], (equation 47) [53]. Diynes were also prepared by the alkylation of alkynyl iodides by alkynes (equation 49) [54]. Alkyl acetates having halides on the olefin were alkynylated at the halogen-bearing position using palladium(0) catalysts (equation 50) [55].



(44)

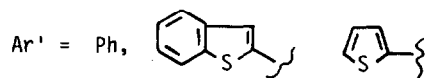
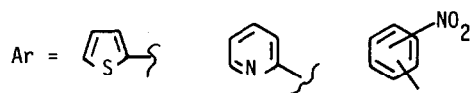
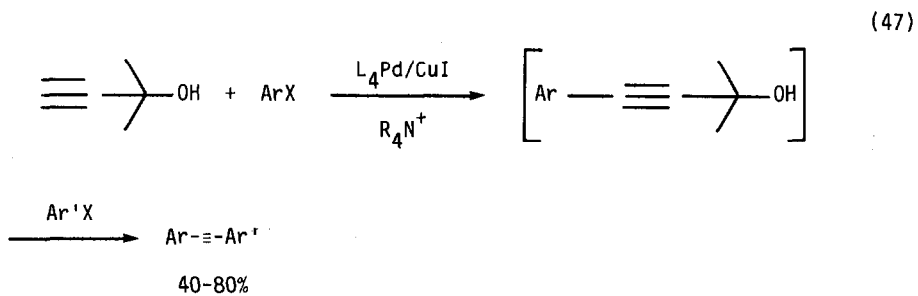
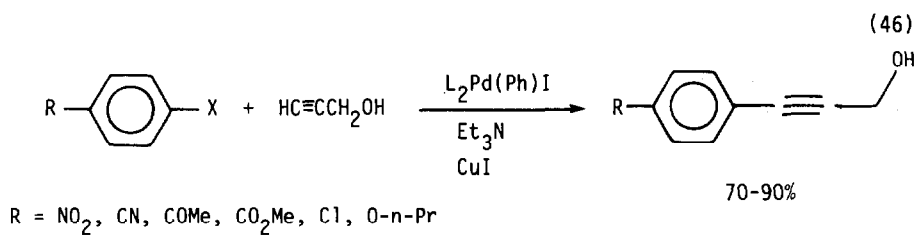
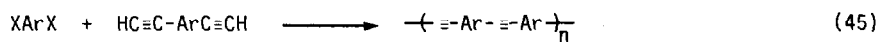
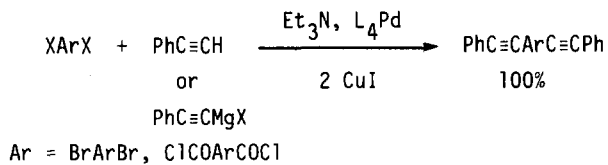

(48)

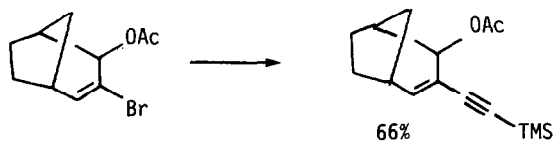
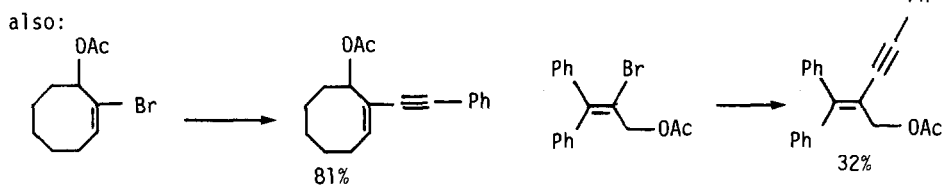
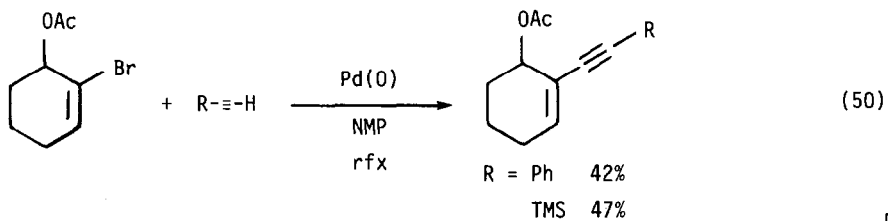
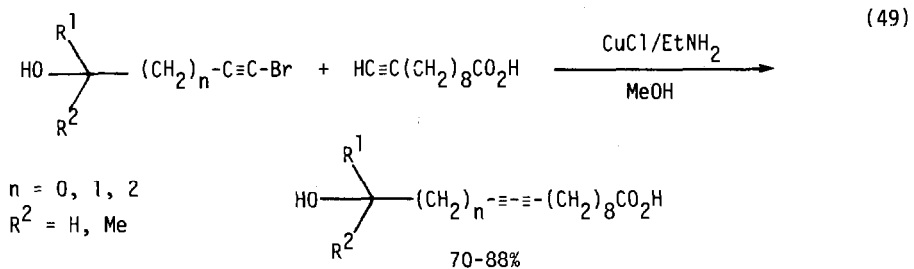
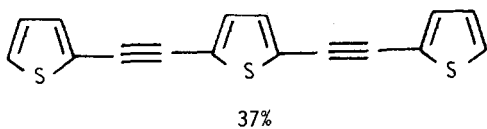
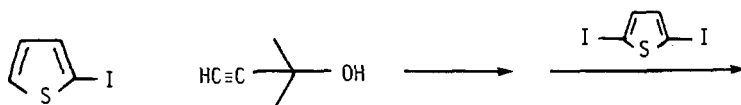

Vinylcuprates, from direct carbocupration of alkynes, alkylated a variety of functionalized organic halides (equation 51) [56], (equations 52, 53, and 54) [57]. Vinyl cuprates were used in a general approach to conjugated dienic insect sex pheromones (equation 55) [58].

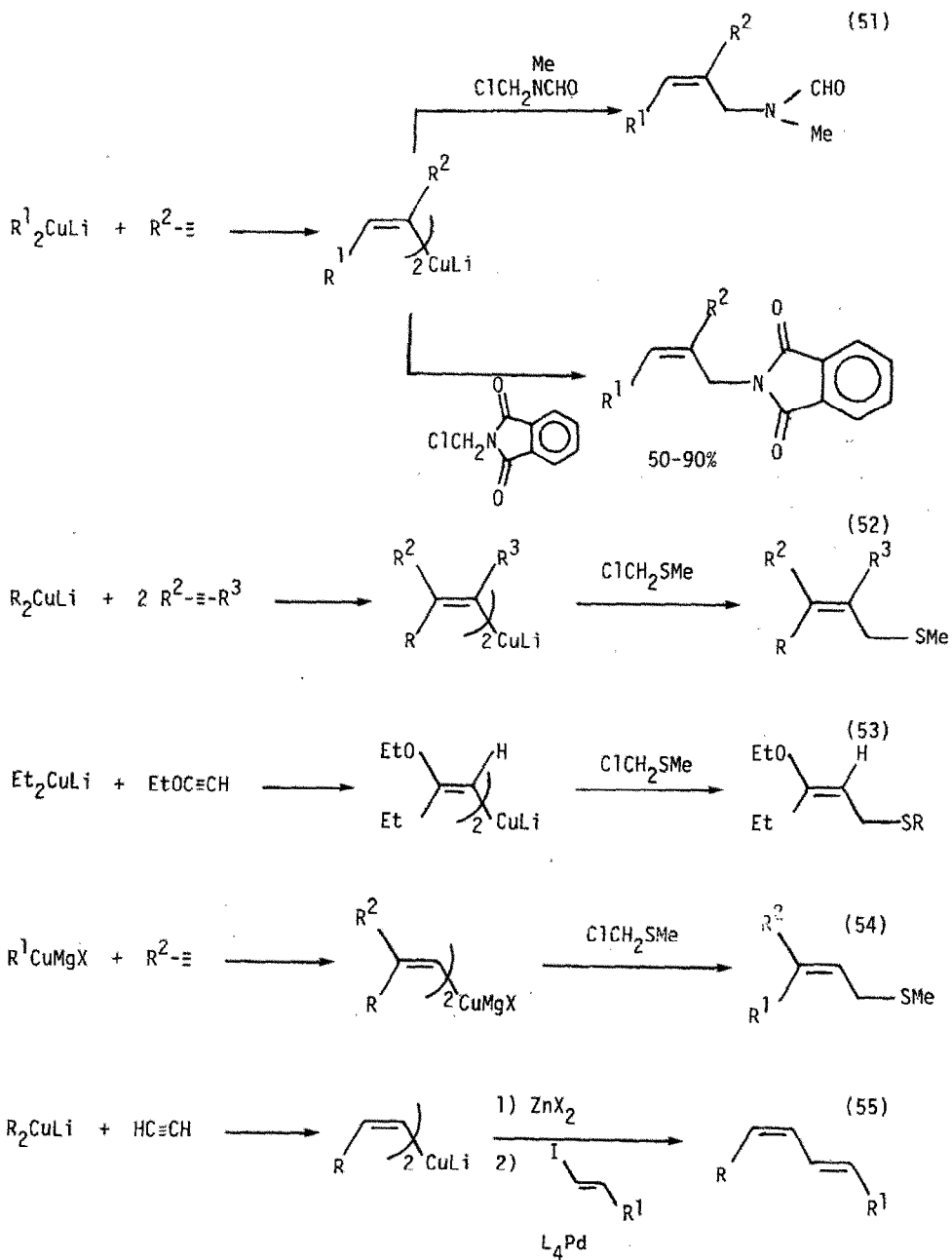

(55 continued)

Made:

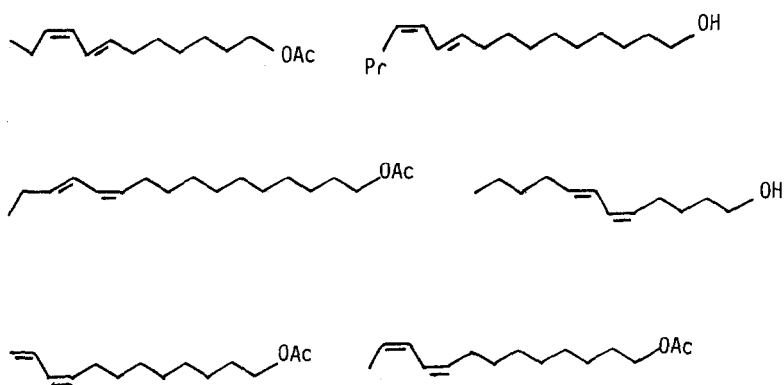

Cyclic olefins were prepared from  $\omega$ -haloalkynes using trimethylaluminum/zirconocene dichloride combinations (equations 56-58) [59]. Diphosphines chelated to transition metals were alkylated by deprotonation/alkylation with organic halides (equation 59) [60].

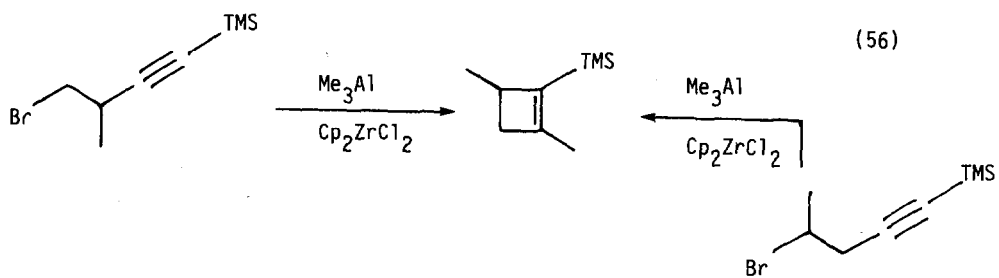

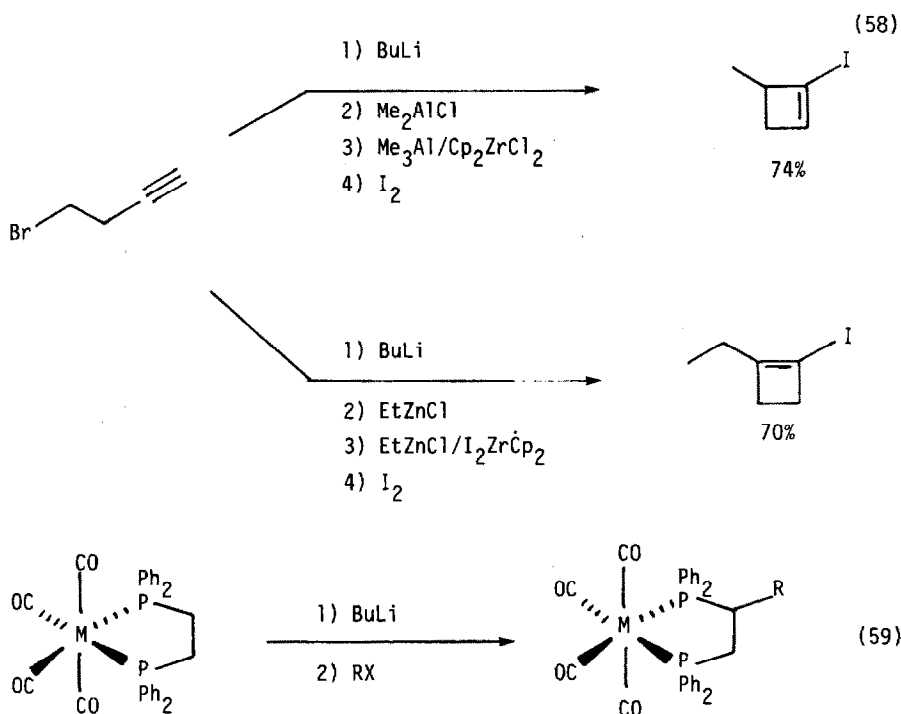

## 2. Alkylation of Acid Derivatives

Alkylmanganese iodides alkylated acid chlorides to ketones (equation 60). Trifluoroketones were prepared from alkylation of trifluoroacetic anhydride (equation 61) [61]. The effects of leaving groups on this reaction were studied [62]. Iron(III) acetylacetonate catalyzed the alkylation of acid halides to ketones by Grignard reagents (equation 62) [63]. Palladium(II) catalysts promoted the alkylation of acid chlorides by dialkylzinc reagents (equation 63) [64]. The palladium-catalyzed coupling of acid chlorides with organotin compounds was the subject of a dissertation [65]. Dibenzyl ketones were produced by the metallic nickel promoted coupling of benzyl halides with the half ester of oxallyl chloride (equation 64) [66]. Fluorinated acid chlorides were converted to fluorinated alkynes via organocopper chemistry (equation 65) [67]. Benzoyl cyanide condensed at the nitrile carbon with  $\beta$ -diketones in the presence of nickel(II) acetylacetonate catalysts (equation 66) [68]. Lauroyl chloride was converted to lauryl alcohol by treatment with butylmagnesium chloride and titanocene dichloride [69].

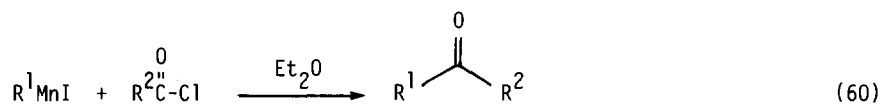

40-90%

$R^1 = n-C_7, n-Bu-\equiv, n-C_{10}, Bu_2C=CH-, n-C_6-\equiv, n-Bu,$

$R^2 = CCl_3, CF_3, CHCl_2, CH_2Cl, (CH_2)_3Cl, (CH_2)_{10}Br, CH_2OEt, CH_2CH_2OEt, C_6H_4OMe, CH_2SPh, (CH_2)_3SPh$

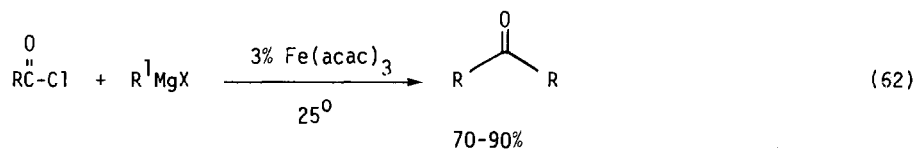
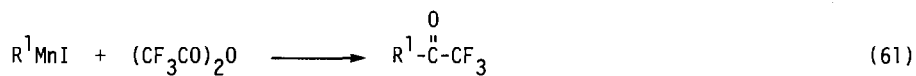

70-90%

$R = n-C_{10}, n-C_5, Me, n-Pr, i-Pr, t-Bu, Ph$

$R^1 = Me, n-C_5, n-C_9, n-C_{10}, i-Bu, t-Bu, Ph, i-Pr, Ph$

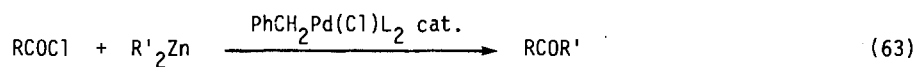

high yields

$R = n-C_3, n-C_7, Me, Ph, p-tol$

$R' = n-Bu, n-Pr, i-Pr, Ph$

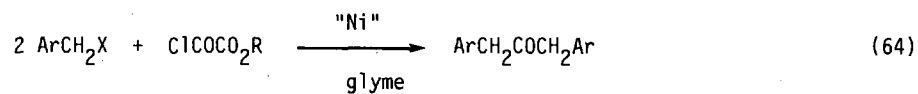

35-60%

$NiI_2 + Li(naphth)$

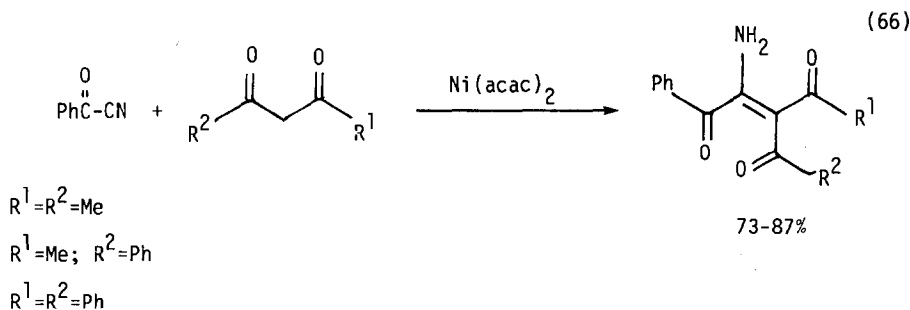
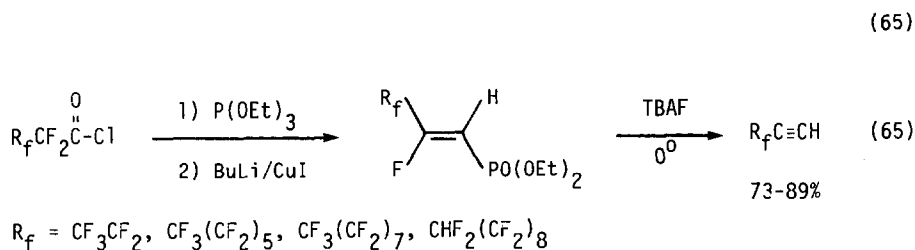

### 3. Alkylation of Olefins.

Palladium(II) assisted reactions of monoolefins has been reviewed (73 references) [70]. "Nucleophilic Addition to Coordinated Cyclic  $\pi$ -Hydrocarbons - Mechanistic and Synthetic Studies" is the subject of a review with 127 references [71]. Carbometallation-addition of organometallic compounds to isolated multiple bonds in functionally substituted compounds has been reviewed (91 references) [72]. "Organic Synthesis in the Presence of Catalyst. Hydroalkylation" is the title of a review with 25 reference [73].

Palladium(0) catalyzed oxidative addition/insertion chemistry (Heck Reaction) continues to be useful for the arylation of olefins. Several technical refinements have substantially increased the utility of this process. By using a mixed catalyst system consisting of  $\text{Pd(OAc)}_2/\text{Bu}_4\text{NCl}/\text{NaHCO}_3$ , olefins can be arylated at  $25^\circ$  rather than the normal  $80-100^\circ$  (equation 67) [74]. Conditions have also been developed to make normally unreactive aryl chlorides react [75]. Another clever solution to the reactivity problem is to use aroyl chlorides as substrates. Decarbonylation ensues along the way, permitting facile arylation of olefins (equation 68) [76]. When the arylation process was carried out in the presence of formic acid, reduced products were obtained (equation 69) [77][78]. Vinyl triflates have also been used as sources of vinyl groups in the typical Heck olefination procedure (equation 70) [79].

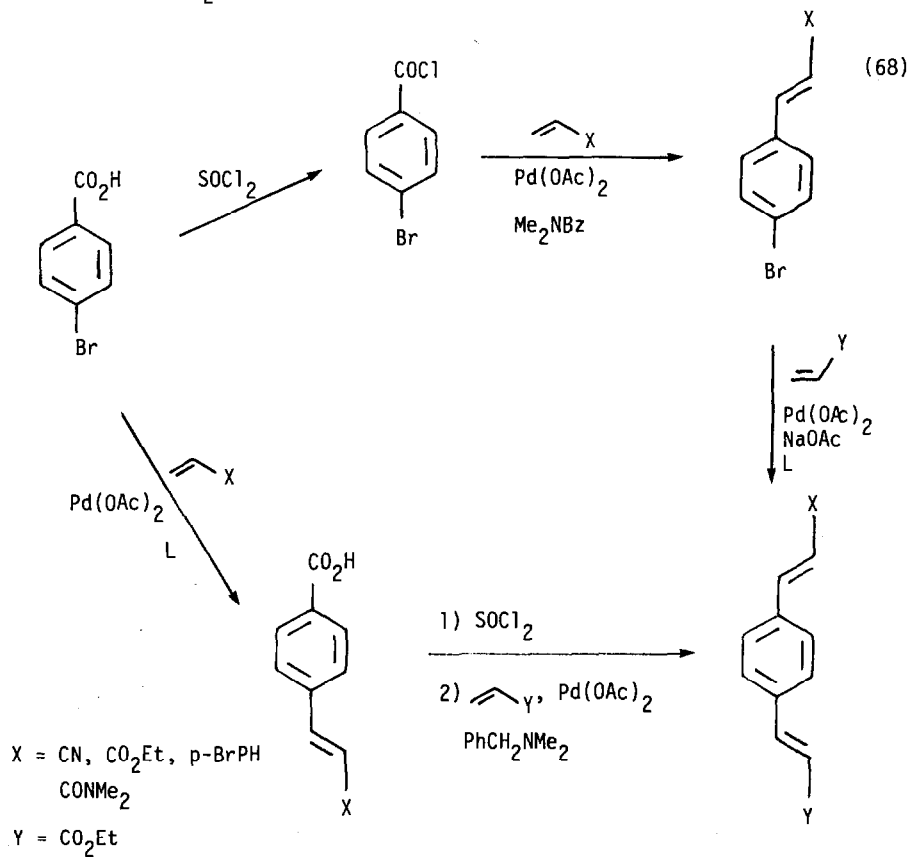
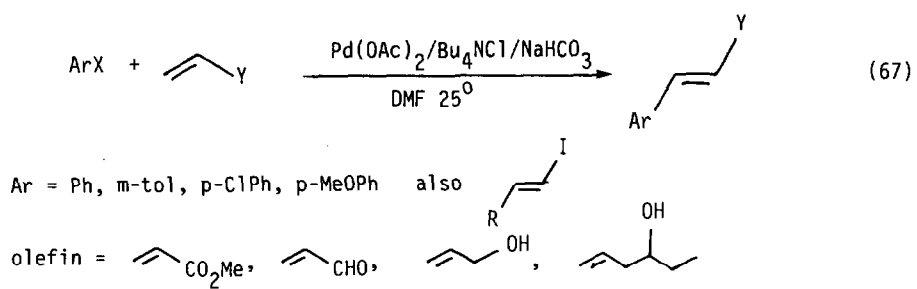



(69)

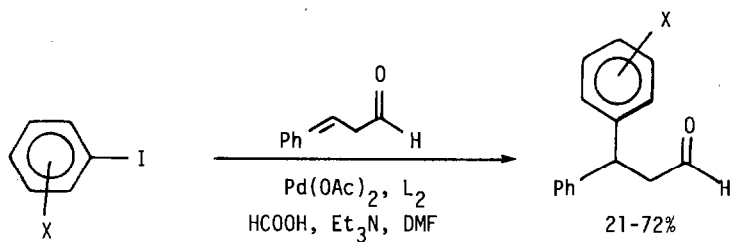

X = H, p-Me, m-HOCH<sub>2</sub>, o-MeO, p-MeO, m-MeCONH, p-MeCONH, p-OH, p-CHO

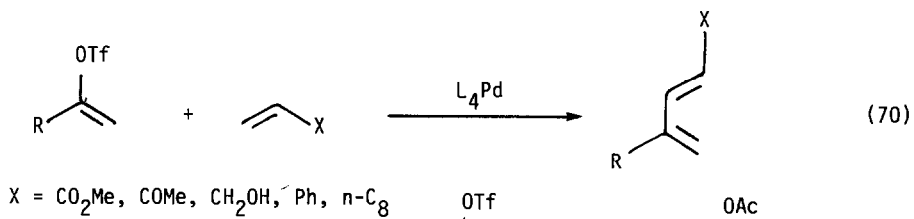
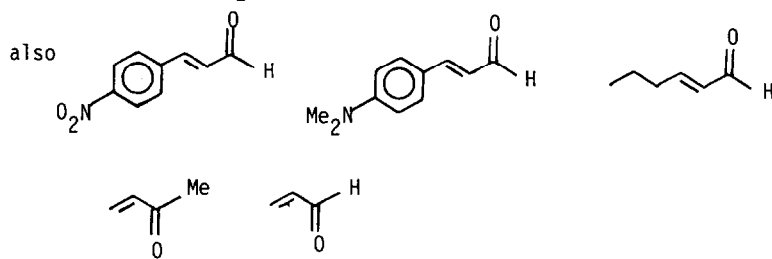

X = CO<sub>2</sub>Me, COMe, CH<sub>2</sub>OH, Ph, n-C<sub>8</sub>

triflate =

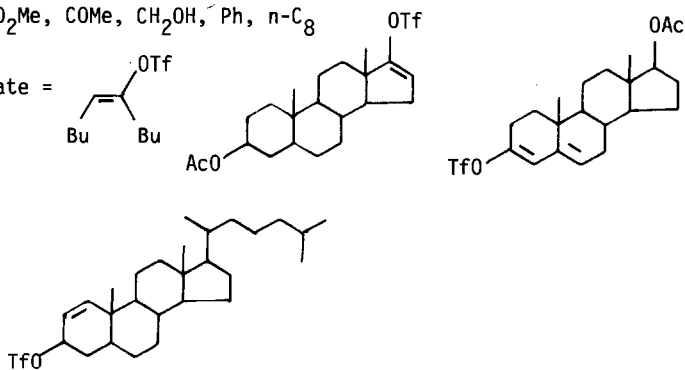

By using DMF as solvent, and adding sodium acetate, aryl chlorides become reactive in "Heck" arylation reactions (equation 71)(equation 72) [80]. Dienes underwent arylation by aryl halides in the presence of palladium catalysts (equation 73) [81]. Vinyl bromides alkylated electrophilic olefins in the presence of palladium catalysts [82], while aryl halides arylated conjugated enols [84]. Palladium catalyzed arylation of olefins was used to synthesize a number of 3- and 4-substituted indoles (equation 74) [84].

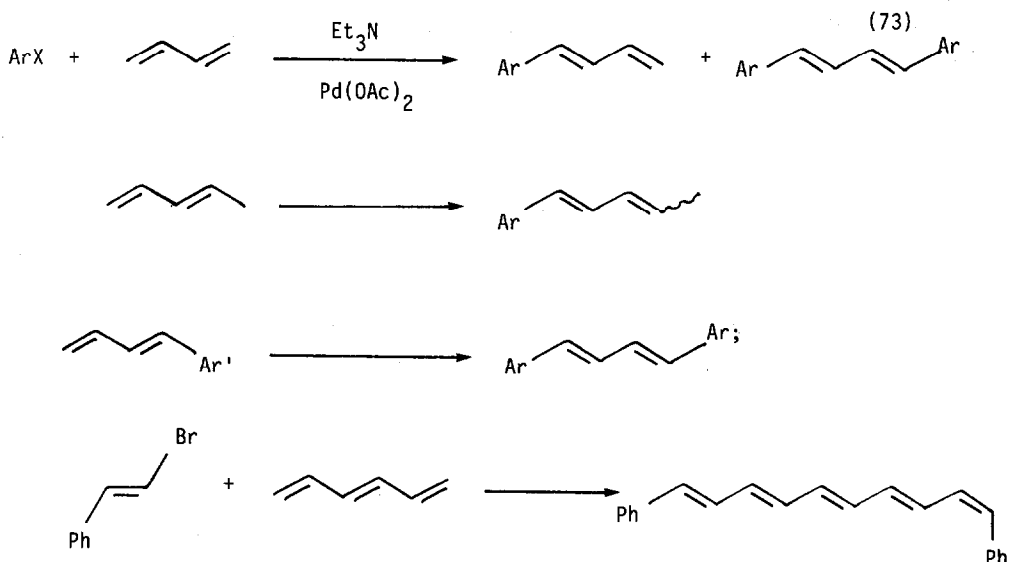
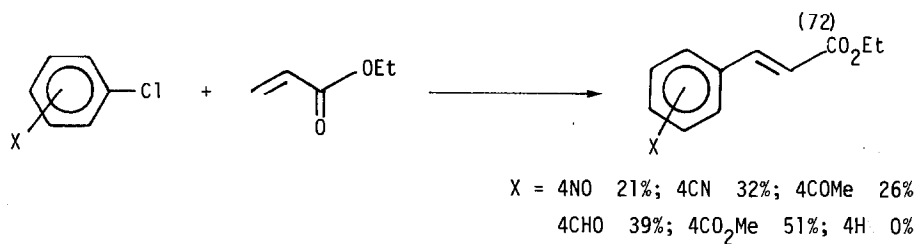
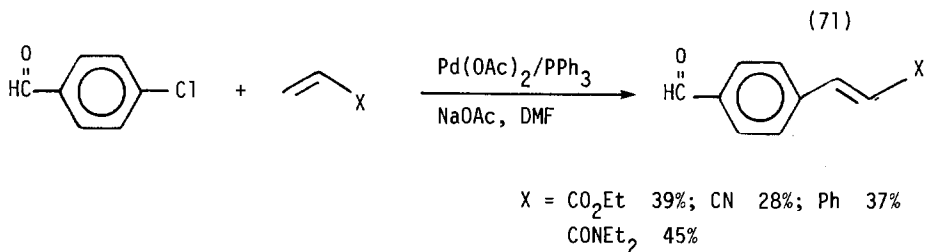

(74)

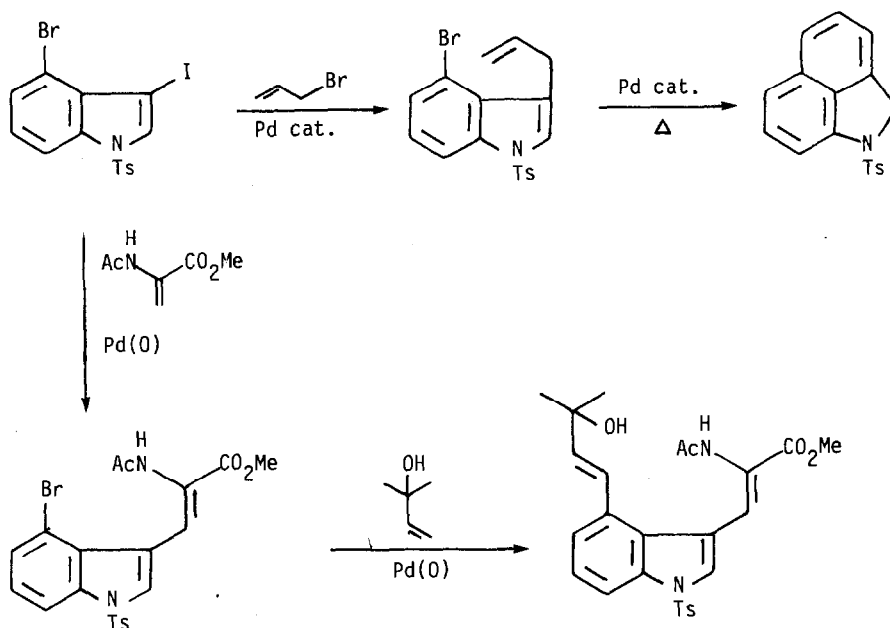

Norbornene underwent a double insertion when treated with aryl halides and alkynes in the presence of palladium(0) catalysts (equation 75) [85]. The same catalyst system dialkylated *p*-bromonitrobenzene (equation 76) [86]. Palladium(0) or rhodium(I) catalysts effected intramolecular alkylations of olefins (equation 77) [87]. Allenes inserted into  $\sigma$ -aryl-palladium(II) complexes to give  $\pi$ -allyl-palladium complexes which underwent nucleophilic attack (equations 78 and 79) [88], (equations 80 and 81) [89].

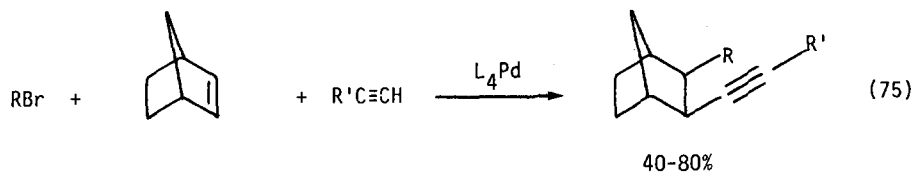

R = Ph, PhCH=CH

R' = Ph, *p*-MeOPh, *p*-NO<sub>2</sub>Ph, *n*-C<sub>6</sub>, C(NH<sub>2</sub>)Me<sub>2</sub>, C(OH)Me<sub>2</sub>

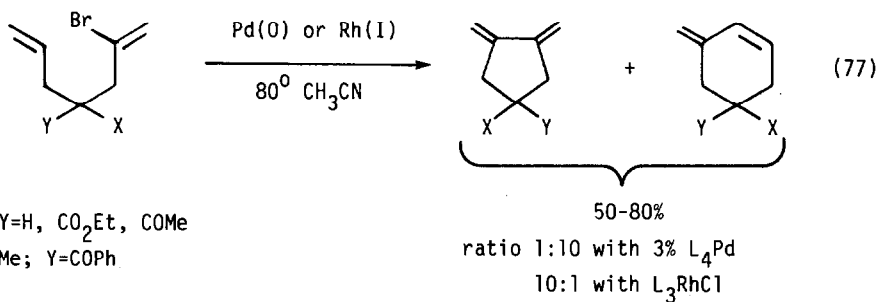
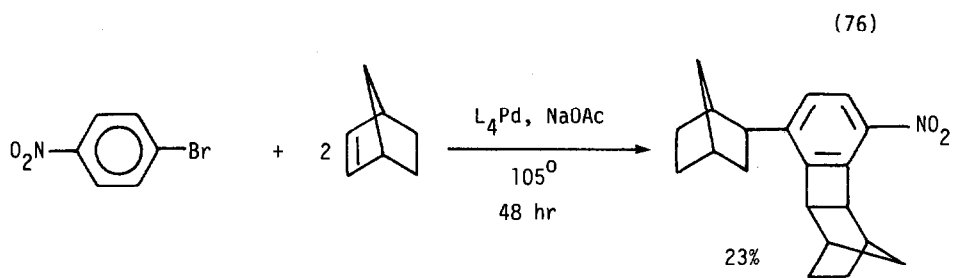

X=Y=H,  $\text{CO}_2\text{Et}$ , COMe  
 X=Me; Y=COPh

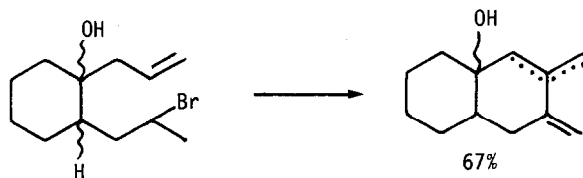
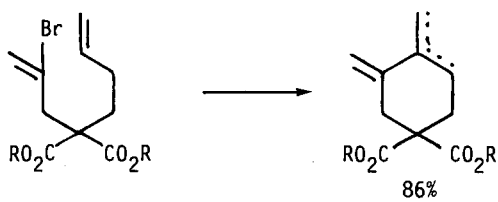
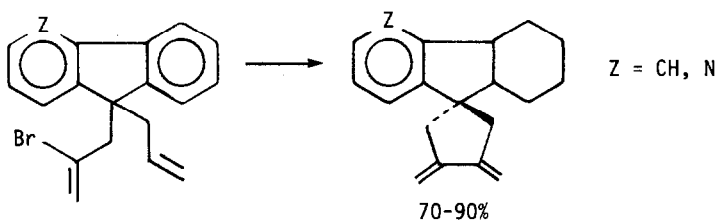

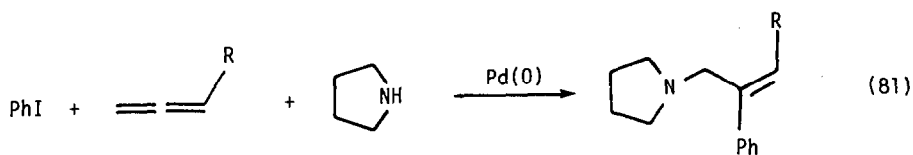
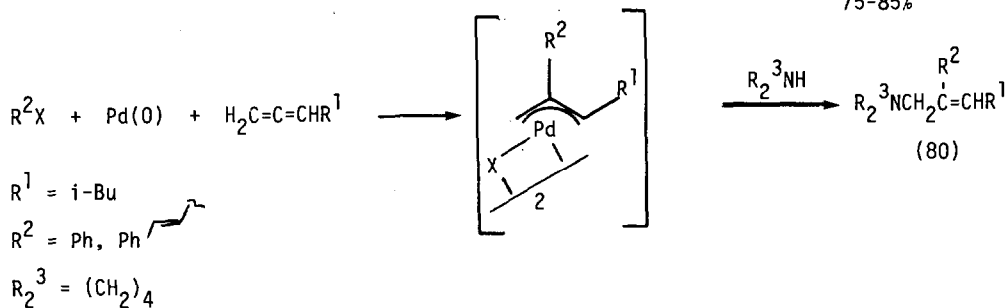
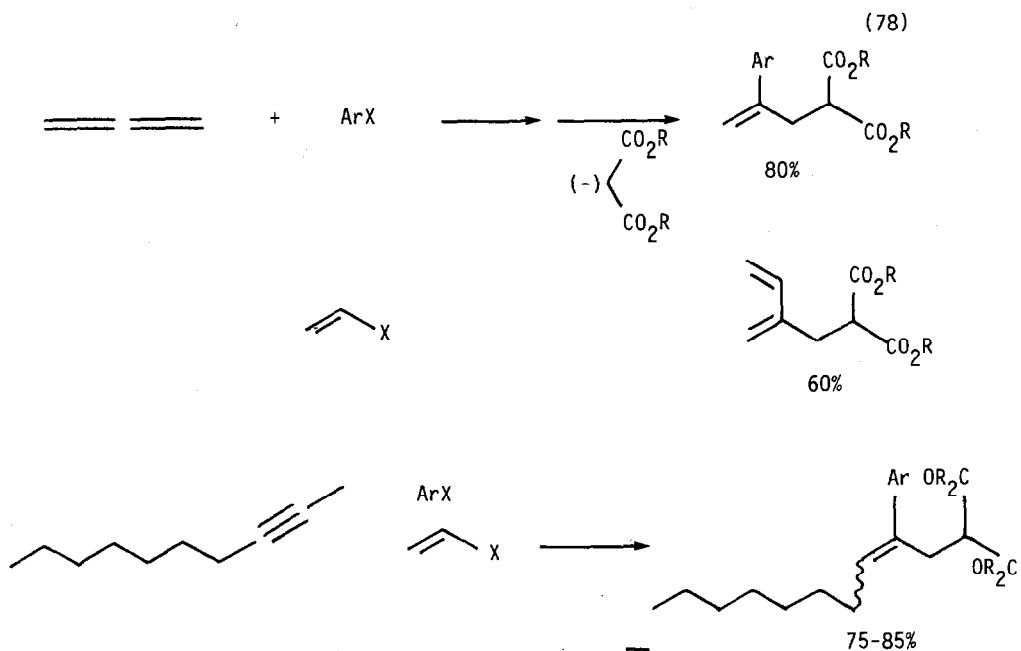

R = PhCHOH 84%; CMe<sub>2</sub>CH<sub>2</sub>OAc 70%; CH(OMe)i-Bu 90%

Direct palladation of aromatics, followed by olefin insertion has also been developed to arylate olefins (equations 82 and 83) [90]. Indoles (equation 84) [91], (equation 85) [92], pyridones (equation 86) and furans or thiophenes (equation 87) [93], and N-acylated pyrroles behave in a similar manner (equation 88) [94]. Vinyl silanes were arylated by aryl diazonium salts (equation 89) [95] and preformed phenylpalladium(II) complexes (equation 90) [96].

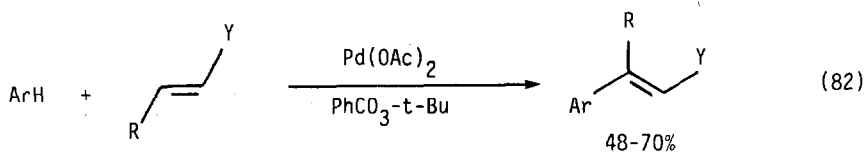

Y = COMe, CHO, CO<sub>2</sub>Me

R = Ph, Me, H

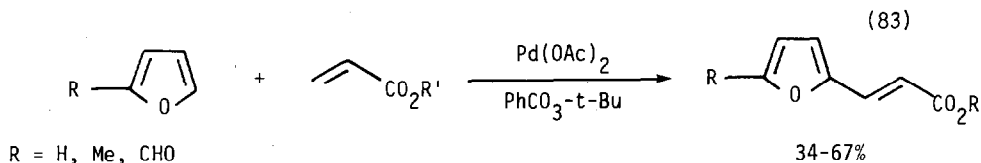

R = H, Me, CHO

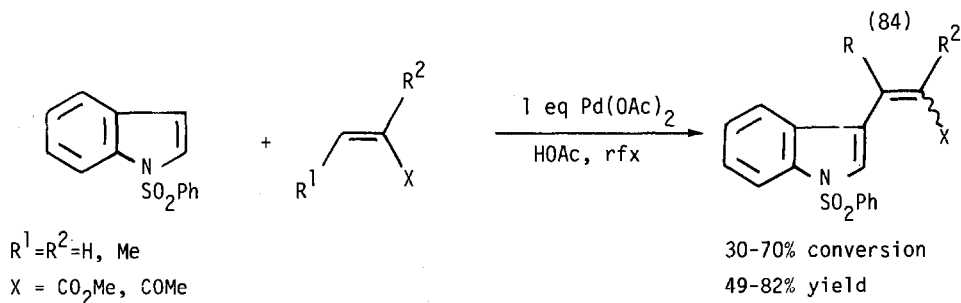

R<sup>1</sup>=R<sup>2</sup>=H, Me

X = CO<sub>2</sub>Me, COMe

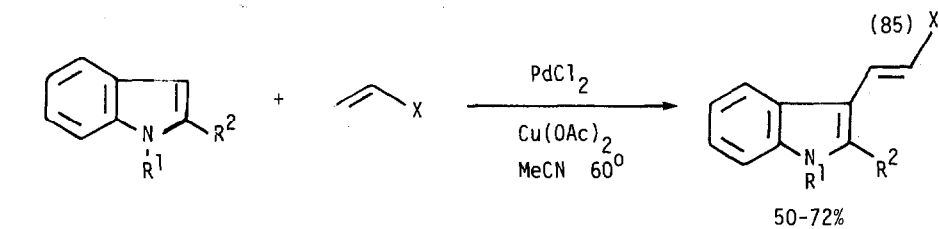

R<sup>1</sup> = H, PhCH<sub>2</sub>

R<sup>2</sup> = H, CO<sub>2</sub>Et

X = COMe, CO<sub>2</sub>Et, Ph, CN

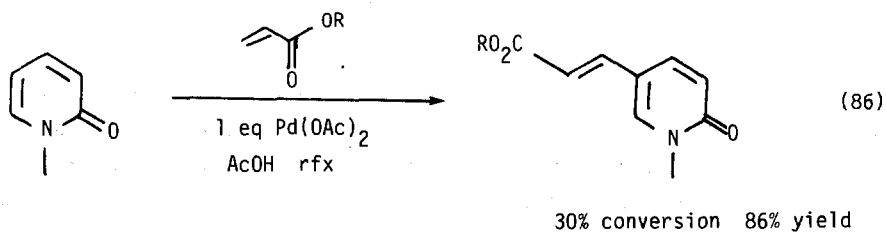

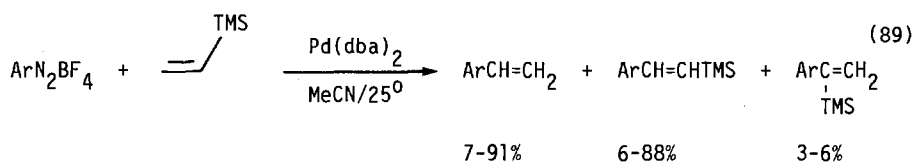
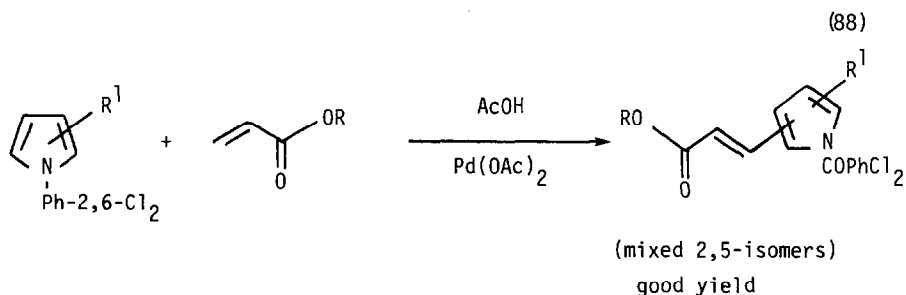
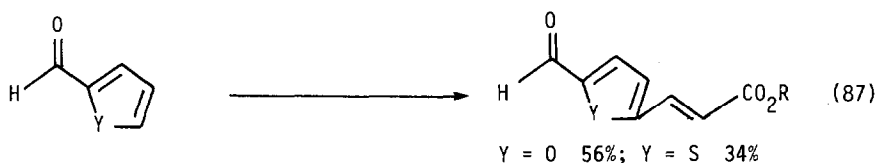

distribution depends on conditions

80-100%

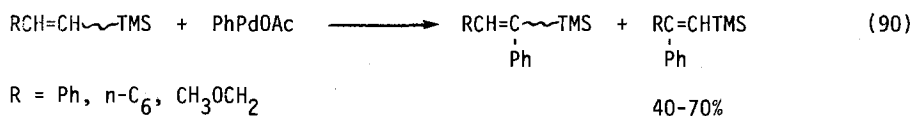

Transmetalation/insertion has been extensively developed for the alkylation of olefins. A number of heterocycles have been prepared by *o*-thallation of aromatic compounds, followed by transmetalation to palladium and insertion (equations 91-94) [97], (equation 95) [98]. Insertion of dienes led to  $\pi$ -allyls, which also have been converted into heterocycles (equations 96-101) [99].  $\pi$ -Allylpalladium complexes were also available from vinylcyclopropanes and -butanes (equation 102) [100], and  $\alpha,\omega$ -dienes (equation 103) [101].

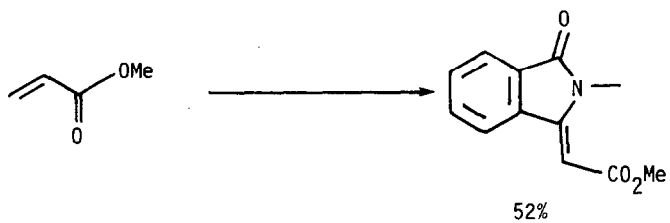
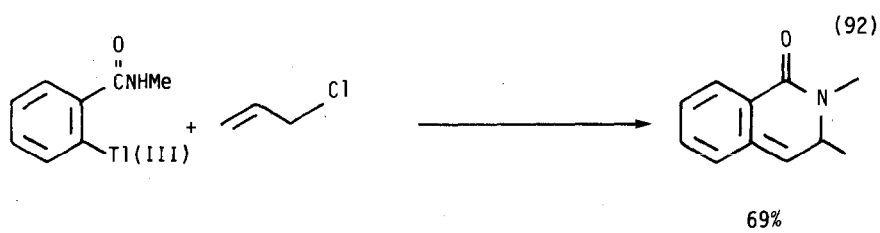
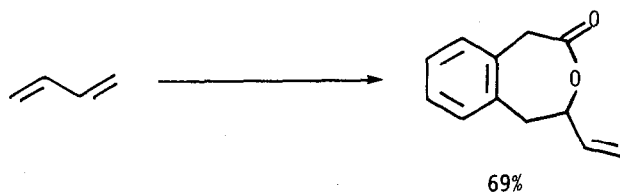
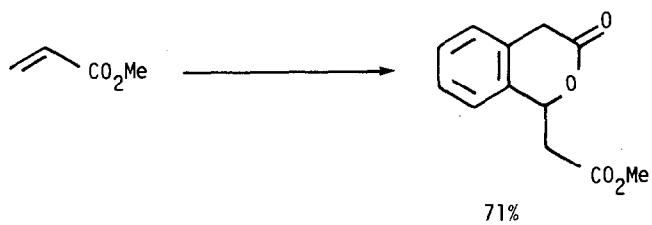
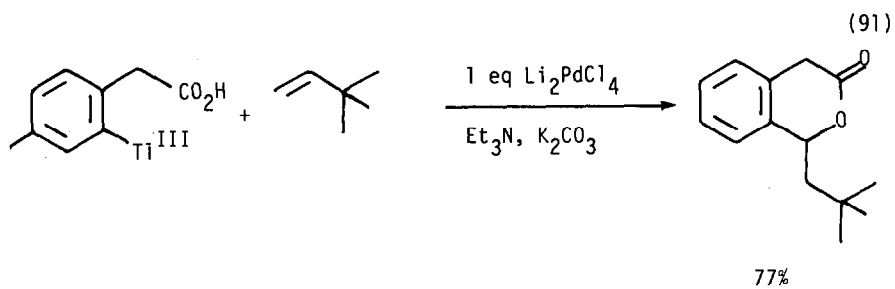



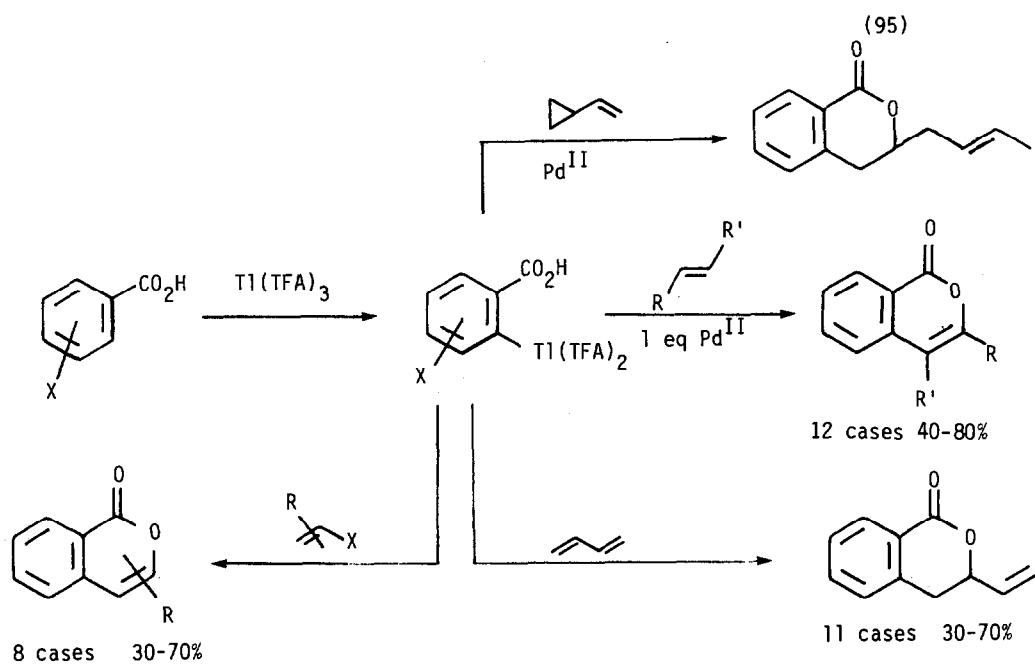
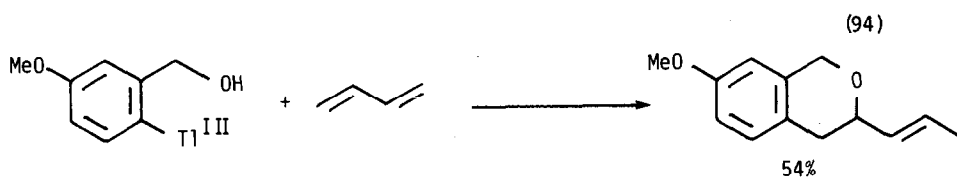
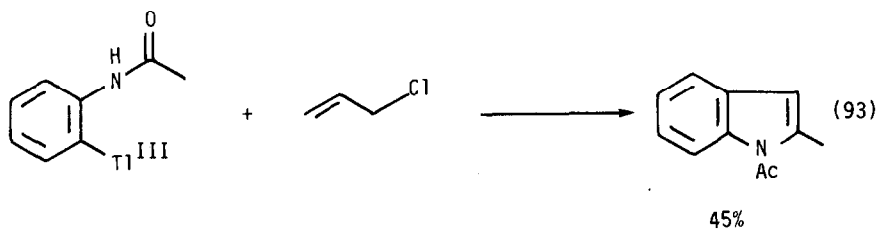

R = H, n-Bu, Ph, t-Bu, CO<sub>2</sub>Me, CN, Me

R' = H, Me, (CH<sub>2</sub>)<sub>4</sub>

X = H, 5 Cl, 5 Me, 3 MeO

Y = Br, OAc, I

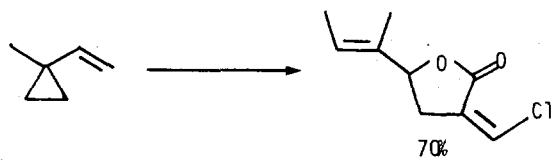
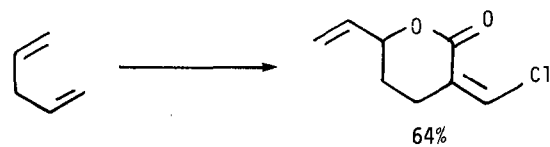
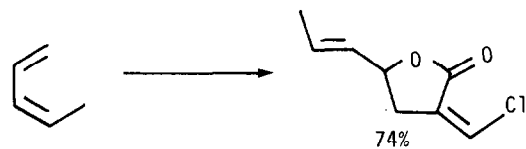
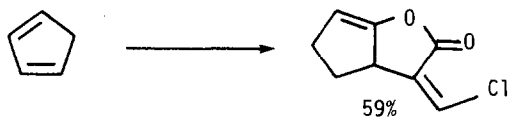
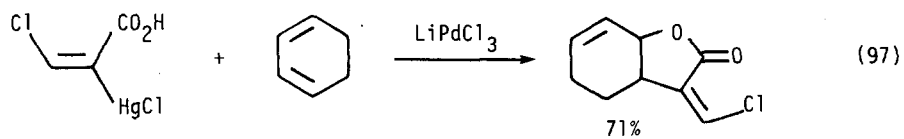
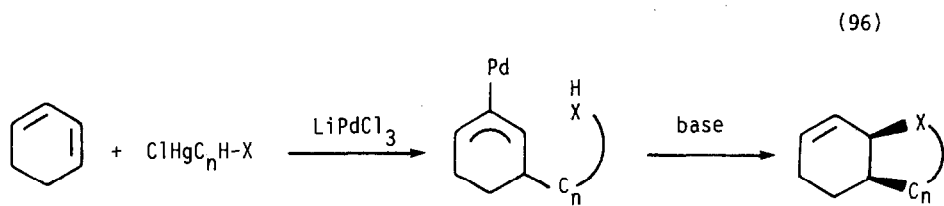

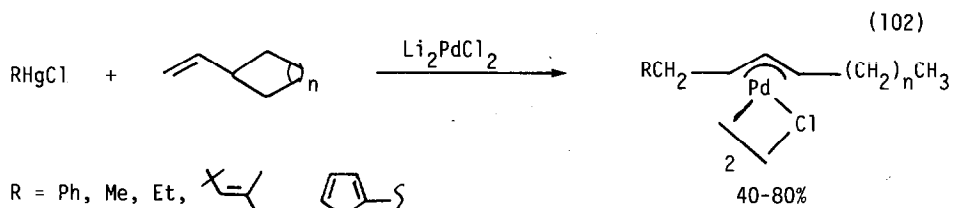
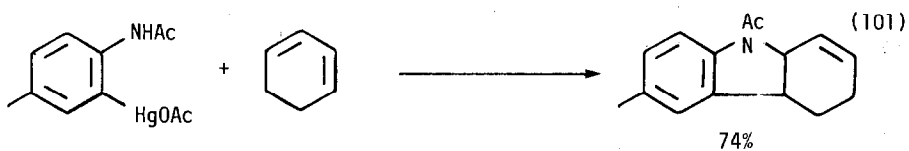
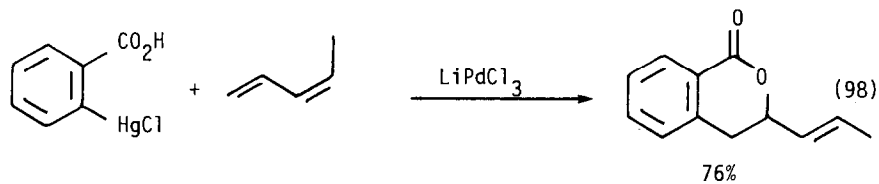

R = Ph, Me, Et,

olefin =

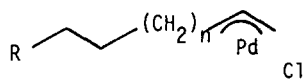
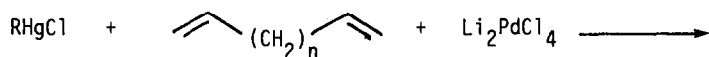

2

R = Ph, MeO<sub>2</sub>C, Me<sub>2</sub>Et  
n = 1, 2, 3, 4

Cyclopalladation of N,N-dimethyl-C-phenylglycine ethyl ester [102] has been effected. The role of base in the cyclopalladation of sterically hindered amines has been probed [103], as has the exchange of cyclopalladated ligands in chloro-bridged palladium(II) complexes [104]. Ferrocene analogs of prostaglandins have been synthesized using asymmetric cyclopalladation [105]. The kinetics and mechanism of vinylation of ortho-palladated N,N-dialkylbenzylamines by parasubstituted styrenes has been studied [106]. Rhodium(I) salts catalyzed the conversion of ortho-allylbenzaldehyde to indane (equation 104) [107]. Iron(II) salts cyclized ω-olefinic halides (equation 105) [108]. Allenes were alkylated by organocuprates (equation 106) [109], (equation 107) [110].

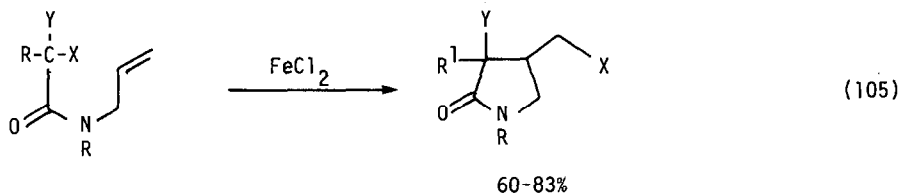
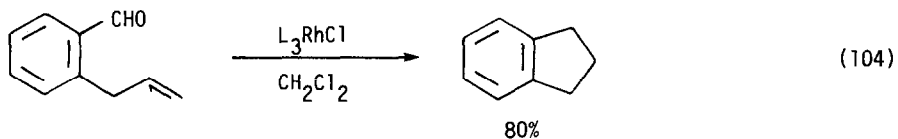

R = Ph, , 3 CF<sub>3</sub>Ph  
R<sup>1</sup> = H, Cl  
X, Y = Cl, Br



(108)

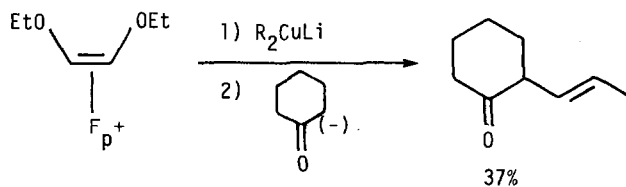
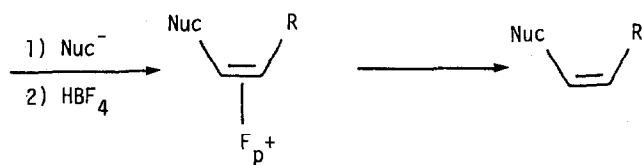
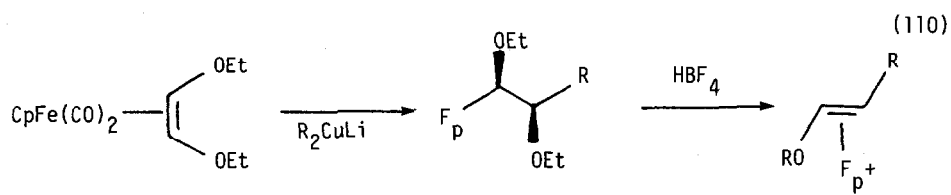
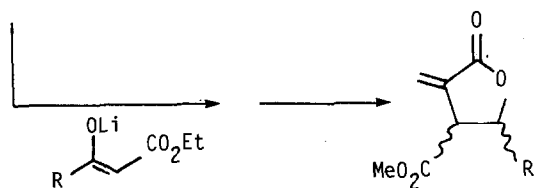
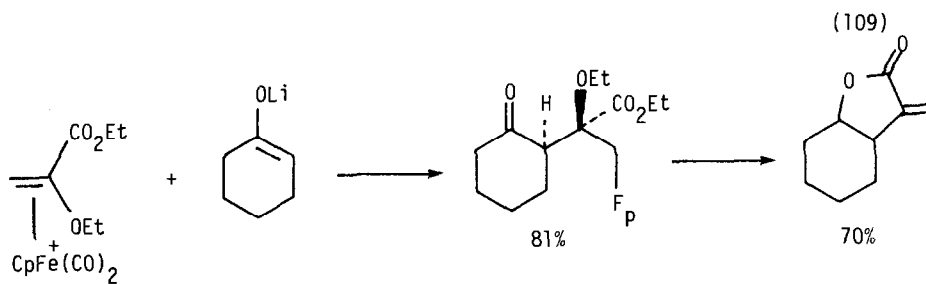
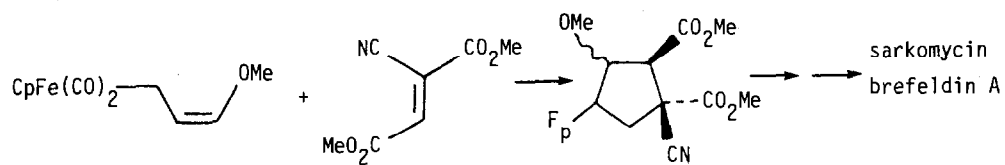

(111)

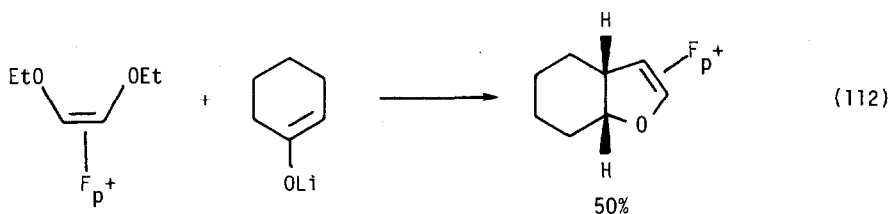

#### 4. Decomposition of Diazoalkanes and Other Cyclopropanations

The mechanism of metal catalyzed decomposition of diazoalkanes to form cyclopropanes has been studied extensively. It has been shown that catalyst-dependent differences in regioselectivity for cyclopropanation results from the degree of charge development in the transition state rather than from intramolecular collapse of the coordinated olefin [115]. The electronic character of the metal catalyst was shown to control the regio- and stereochemistry of the cyclopropanation in equation 113 [116]. The rhodium(II) acetate catalyzed cyclopropanation of olefins with ethyl diazoacetate was compared with the stoichiometric reactions of olefins with tungsten carbene complexes, and the two reactions were claimed to proceed by similar mechanisms [117]. Halogenated olefins were cyclopropanated by ethyl diazoacetate in low yield in the presence of rhodium(II) pivalate complexes (equation 114) [118].

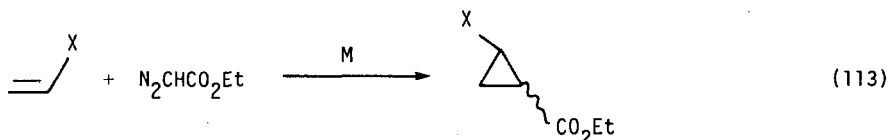

M =  $\text{Rh}_2(\text{OAc})_4$ ,  $\text{CuCl}\cdot\text{P}(\text{O}-i\text{-Pr})_3$ ,  $\text{Rh}_6(\text{CO})_{16}$ ,  $\text{PdCl}_2\cdot 2\text{PhCN}$

X =  $\text{CH}_2\text{Br}$ ,  $\text{CH}_2\text{Cl}$ ,  $\text{OPh}$ ,  $n\text{-Bu}$ ,  $\text{OAc}$ ,  $\text{OEt}$ ,  $\text{OBu}$ ,  $i\text{-Pr}$ ,  $t\text{-Bu}$ ,  $\text{CCl-CH}_2$ ,  $\text{CPh-CH}_2$ ,  
 $\text{CH}_2\text{MeC=CH}_2$ ,  $t\text{-BuC=CH}_2$ ,  $\text{CH-CHOMe}$ ,  $\text{CH-CHCl}$ ,  $\text{C-CHPh}$ ,  $\text{C=CHMe}$

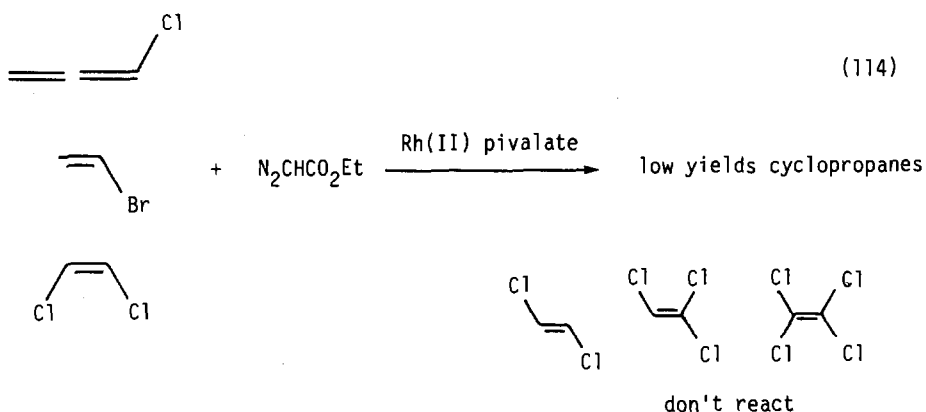

Transition metals also catalyze the insertion reactions of diazoalkanes (equations 115-117) [119]. By using bulky rhodium(II) carboxylates as catalysts the distribution of C-H insertion products was altered [120]. Transition-metal catalyzed insertions have been used to synthesize a number of interesting compounds (equation 118) [121], (equation 119) [122], (equation 120) [123].

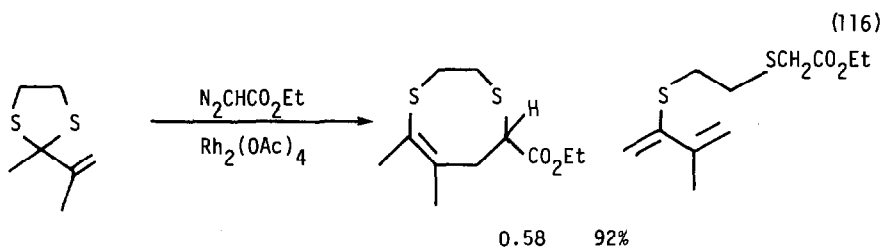
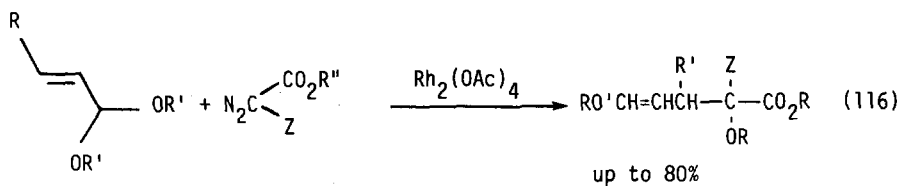
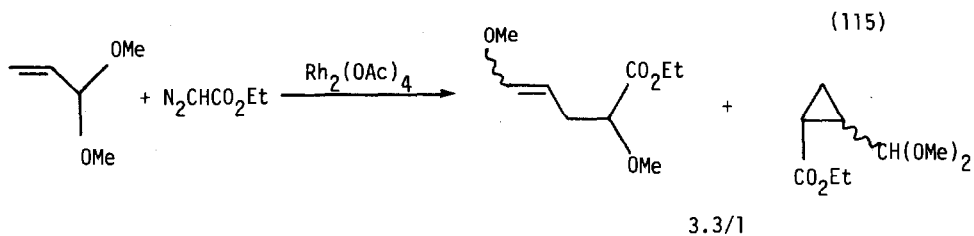



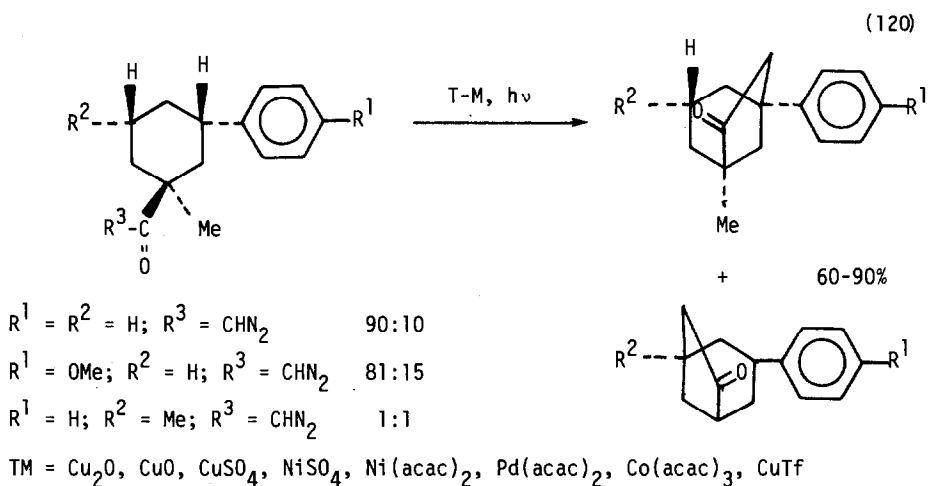
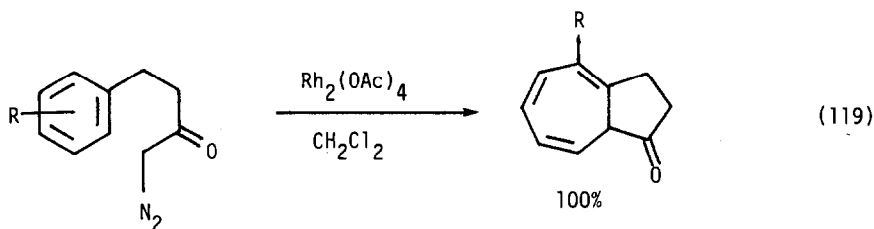
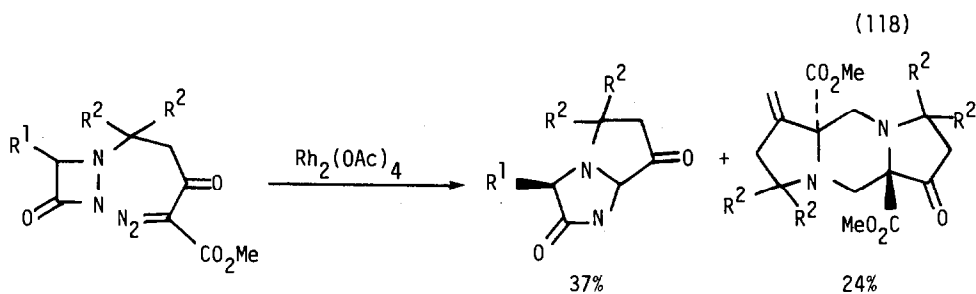

Copper compounds also catalyzed the cyclopropanation of olefins by diazo compounds. Bridged polycyclic systems were made this way (equation 121) [124]. With chiral catalysts, high asymmetric induction was observed (equation 122) [125], (equation 123) [126], (equation 124) [127]. With dienes, mixtures of cyclopropanation products were obtained (equation 125) [128]. With  $C_6$  to  $C_8$  cycloalkenes, yields of cyclopropanation increased with increase in ring size or ring strain.

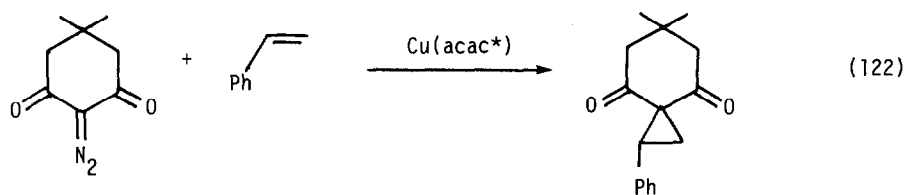
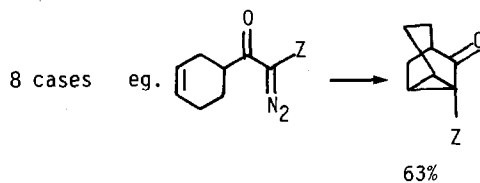
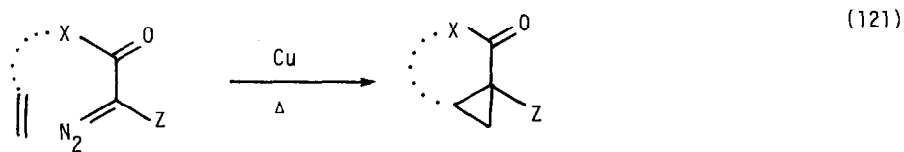

48% yield 100% ee with  
10-methylene facam

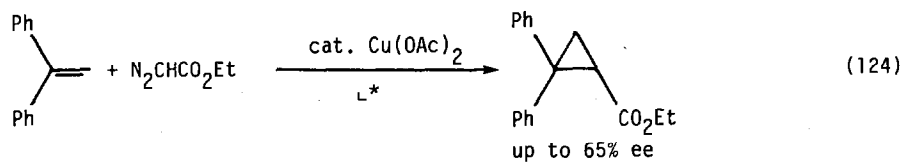
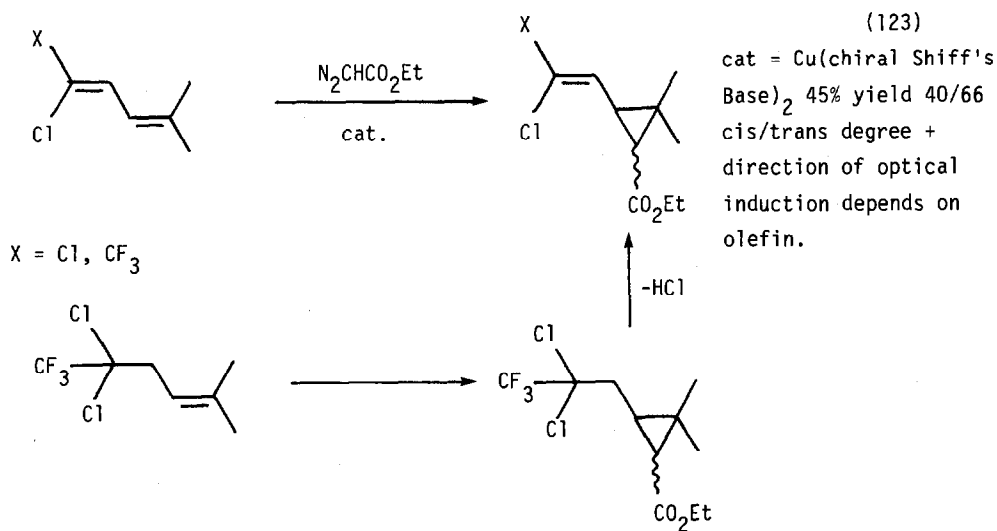

(124 continued)

studied 37 chiral L's

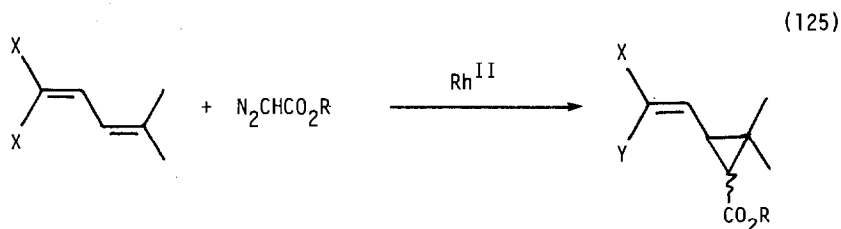
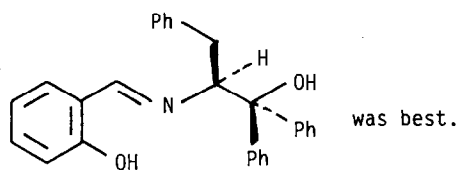

Palladium(II) compounds catalyzed the cyclopropanation of norbornene and norbornadiene by diazomethane [130]. Transition metal phthalocyanine complexes catalyzed the cyclopropanation of styrene by ethyl diazoacetate [131]. Cyclopropanation of styrene by iron carbenes has been the subject of a report [132]. Conjugated iron carbene complexes cyclopropanated olefins (equation 126) [133]. Titanacyclobutanes were converted to cyclopropanes by iodine (equation 127) [134]. Norbornene was cyclopropanated by  $\beta$ -bromostyrene and secondary amines in the presence of palladium(0) catalyst (equation 128) [135]. "Palladium-Assisted Preparation of Cyclopropanes, Conjugated Ketones, and Carbamates" was the title of a dissertation [136].

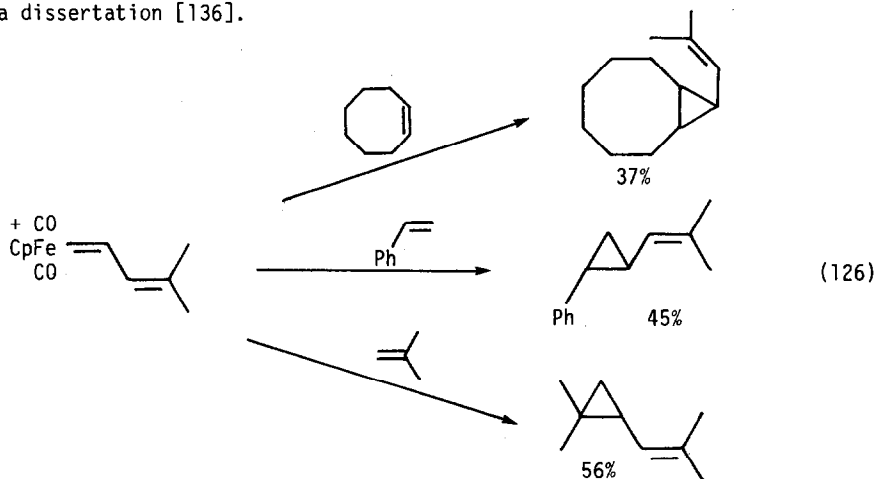

(127)

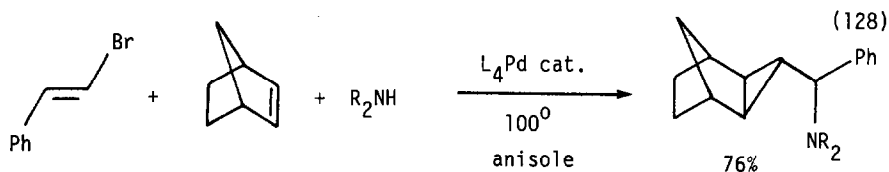
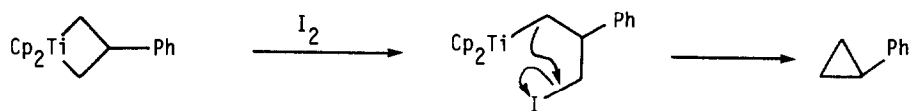

### 5. Cycloaddition Reactions

A dissertation dealing with attempted development of a metal catalyzed [4+1] cycloaddition methodology has appeared [137]. The role of [2+2] cycloaddition type reactions in catalysis was the subject of an article [138]. Iron(III) doped K10 montmorillonite catalyzed a variety of Diels-Alder reactions (equation 129) [139]. Conjugated enones were prepared by the  $\text{Eu}(\text{fod})_3$  catalyzed heteroatom cycloaddition of benzaldehyde to electron-rich dienes (equation 130) [140]. Phosphabenzene coordinated to tungsten(0) underwent Diels-Alder reactions with 2,3-dimethylbutadiene, N-phenylmaleimide and dimethyl acetylene dicarboxylate (equation 131) [141].  $\eta^1$ -Cyclopentadienyl iron complexes underwent Diels-Alder reactions with a number of dienophiles (equation 132) [142]. Oxidative cleavage produced bicyclic esters (equation 133) [143]. The cycloadduct of furans and alkynes were converted to aromatic compounds by  $\text{TiCl}_4/\text{LiAlH}_4$  (equation 134) [144].

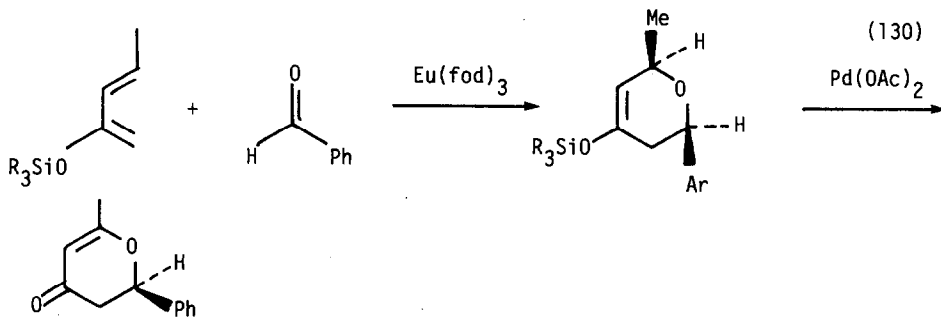
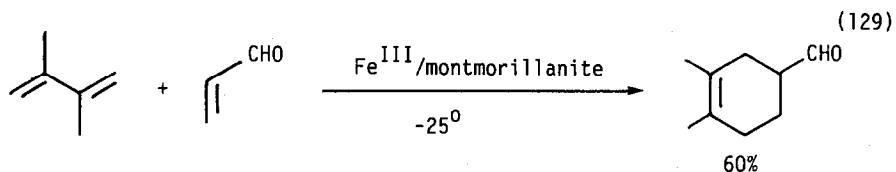

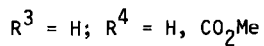
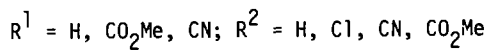
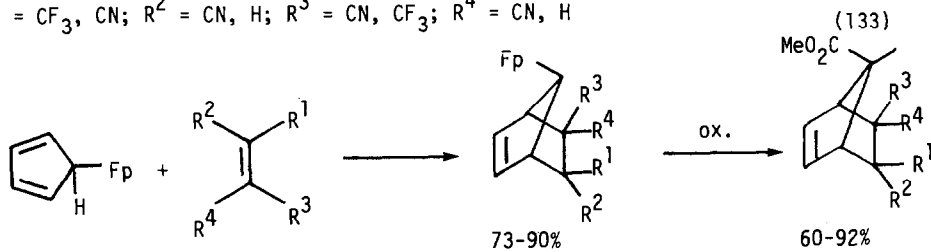
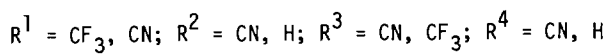
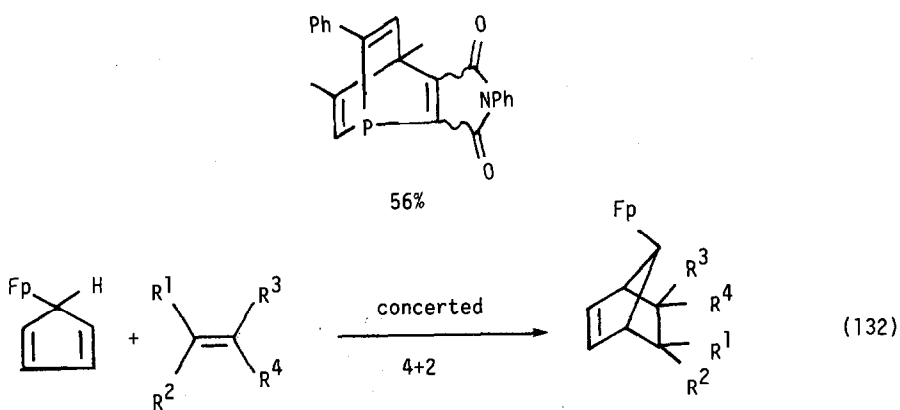
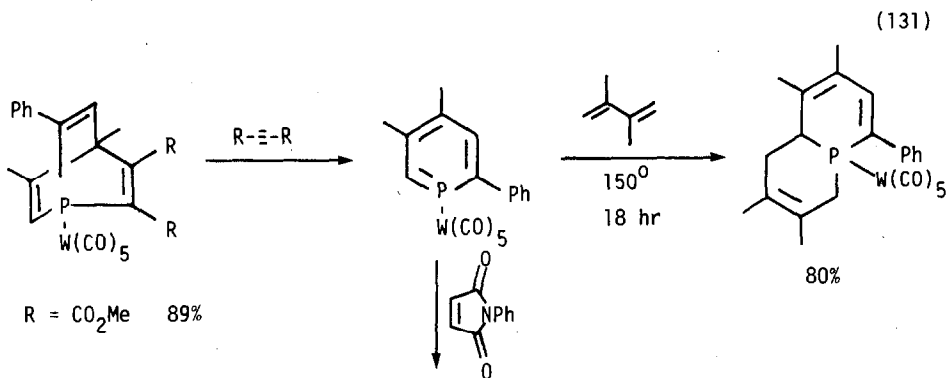

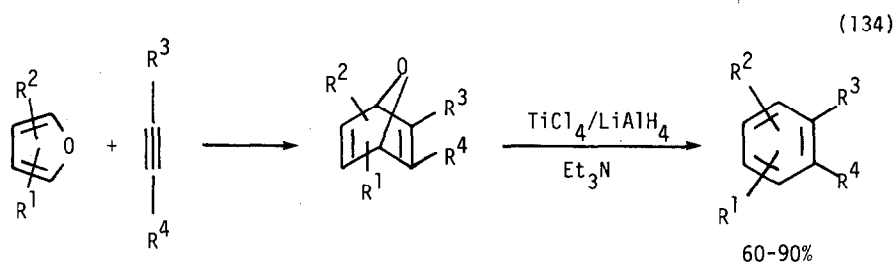

Ketenes cycloadded to  $n^4$ -cycloheptatriene iron complexes in a concerted [2+2] process (equation 135) [145]. Rhenium complexes cyclodimerized 2-butyne (equation 136) [146]. Copper triflate catalyzed the photochemical cycloaddition of *N,N*-diallyl amines to 5,4 ring systems (equations 137-139) [147]. Dienes underwent a similar reaction (equations 140 and 141) [148]. Eneynes underwent an intramolecular cycloaddition when treated with *i*-butylaluminum and zirconocene dichloride (equation 142) [149]. Molybdenum hexacarbonyl catalyzed the cycloaddition of alkynes to oxazolines (equation 143) [150].

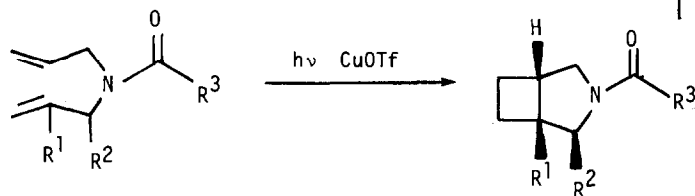
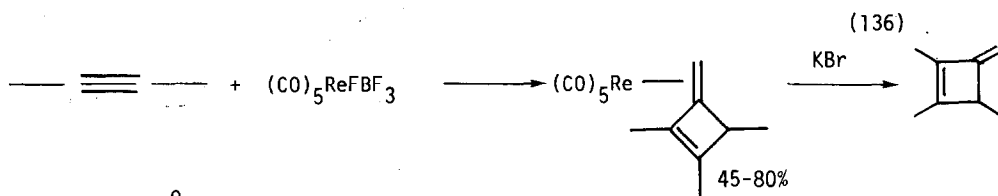
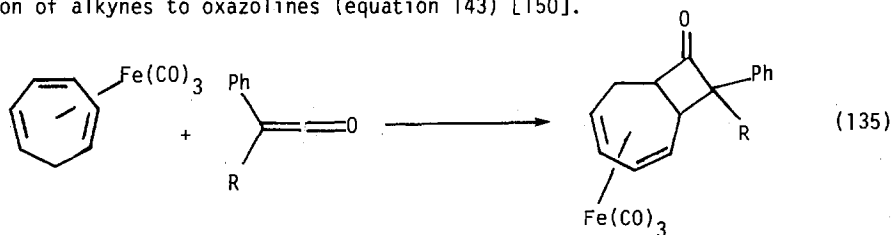

R <sup>1</sup>	R <sup>2</sup>	R <sup>3</sup>	%
H	H	Me	0
H	H	H	0
H	H	OEt	74
H	Me	OEt	60
Me	H	OEt	76

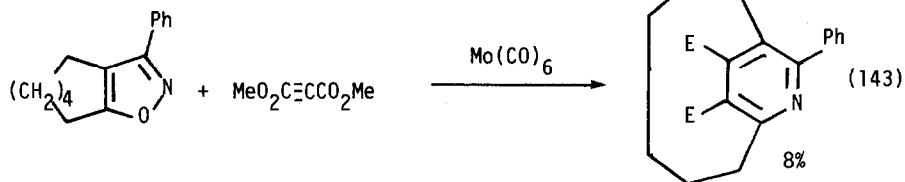
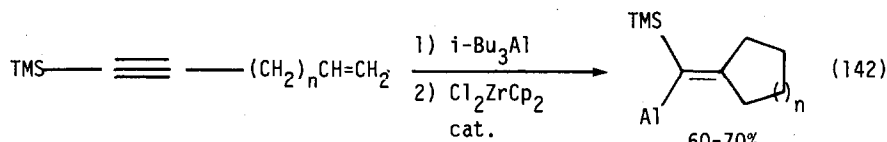
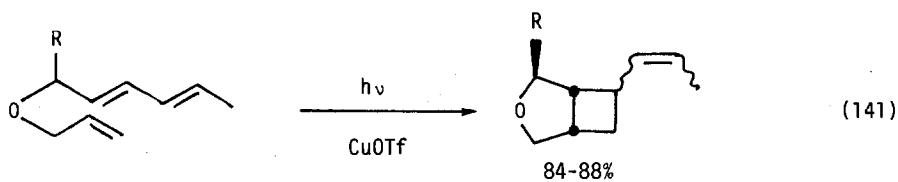
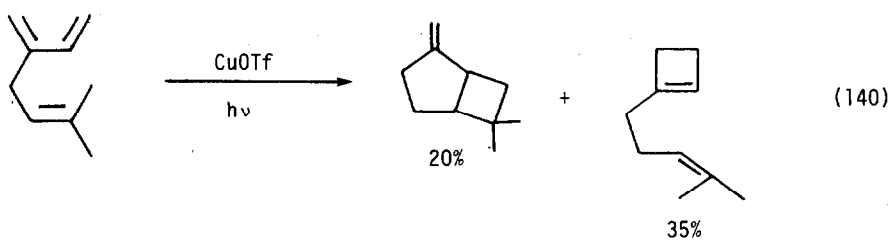
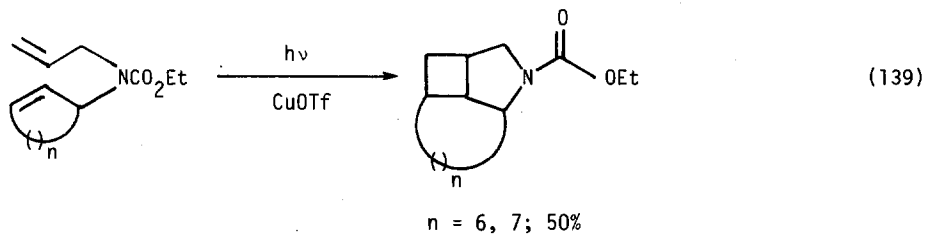
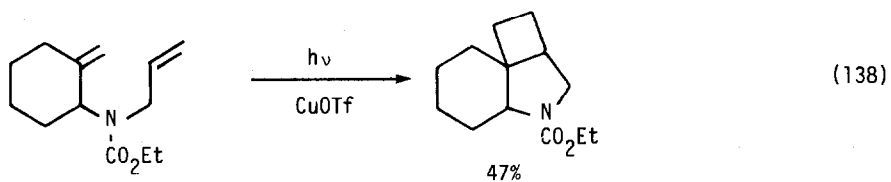

Bis-benzylhalides cyclodimerized when treated with nickel(0) complexes (equation 144) [151]. Reduction by chromium(II) chloride in the presence of dienophiles led to bicyclic systems (equation 145) [152]. Nickel(0) complexes cyclodimerized isocyanates with aldehydes to give complexes that could be converted to a number of unusual systems (equation 146) [153]. Allenes and isocyanates cyclo dimerized in a similar manner (equation 147) [154]. Palladium(0) catalyzed the cycloaddition of electron-deficient olefins with bis-functionalized allyl systems (equation 148) [155].

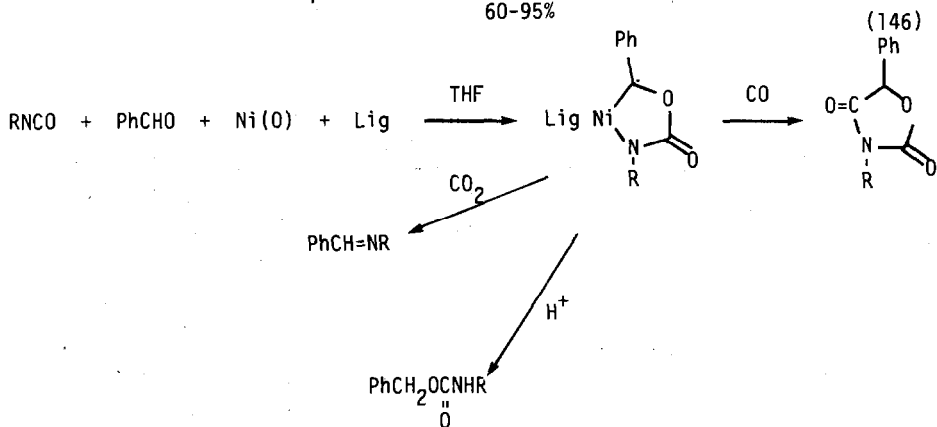
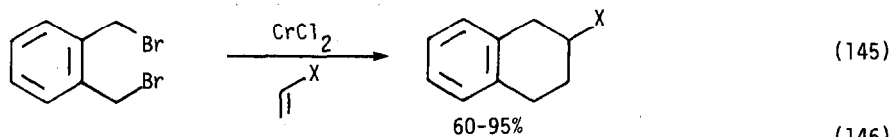
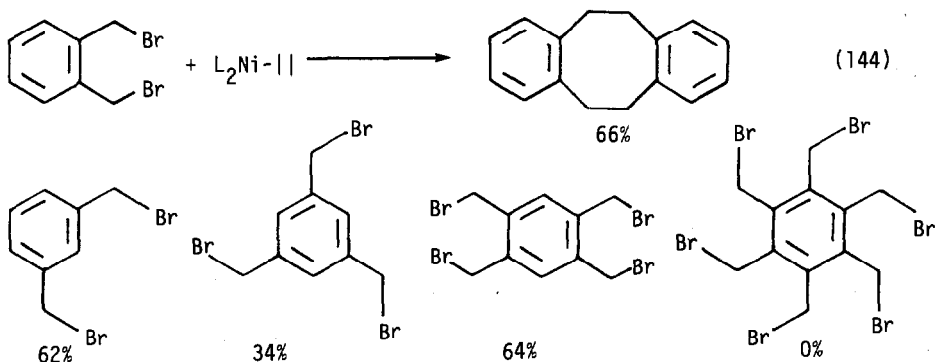



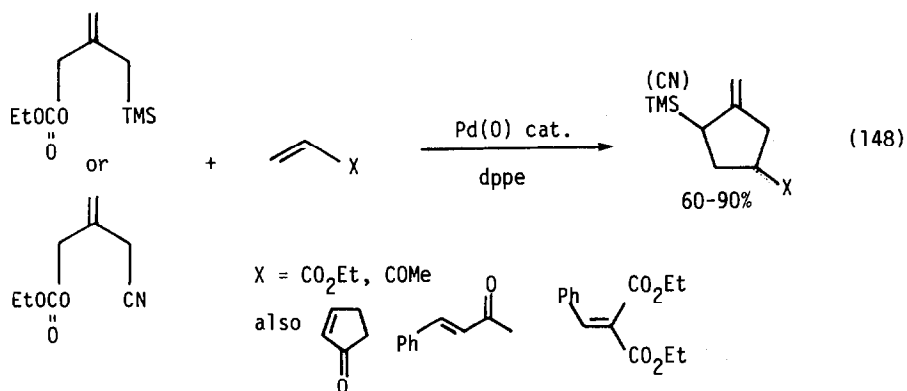
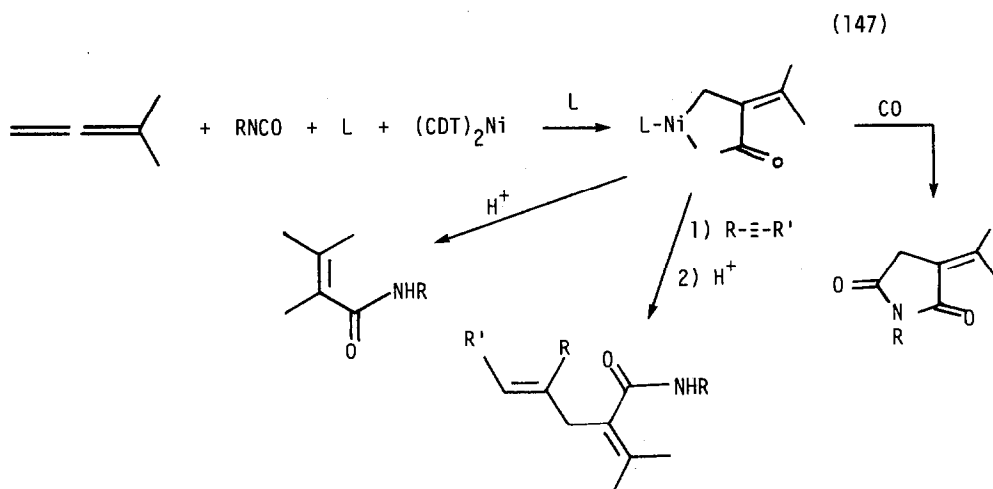

## 6. Alkylation of Alkynes

Trimethylsilyl acetylene was converted to a vinyl cuprate by reaction with organocopper complexes. Substituted vinyl silanes were prepared by treatment of these copper complexes with electrophiles (equation 149) [156], (equation 150) [157]. Reduced nickel salts catalyzed the addition of Grignard reagents to trimethylsilyl acetylenes (equation 151) [158]. Cuprates also alkylated ketals of propiolic aldehydes (equation 152) [159]. Terminal acetylenes were alkylated by organic halides in the presence of amine/copper(I) iodides palladium catalysts [160].

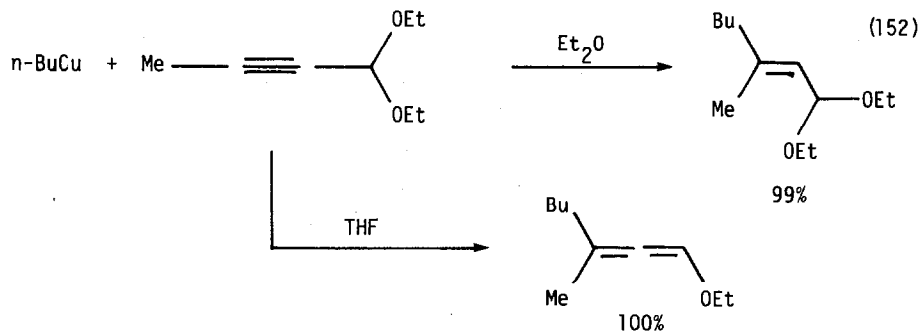
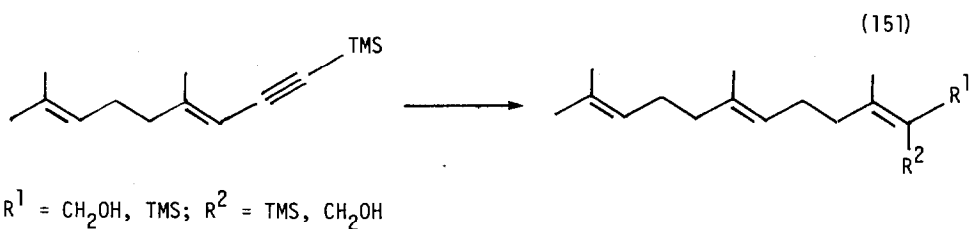
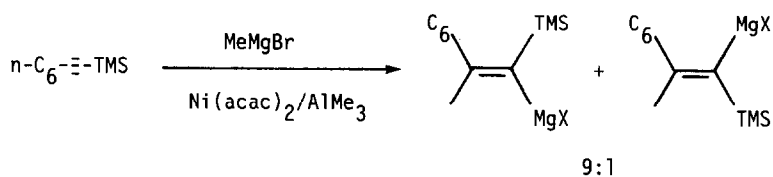
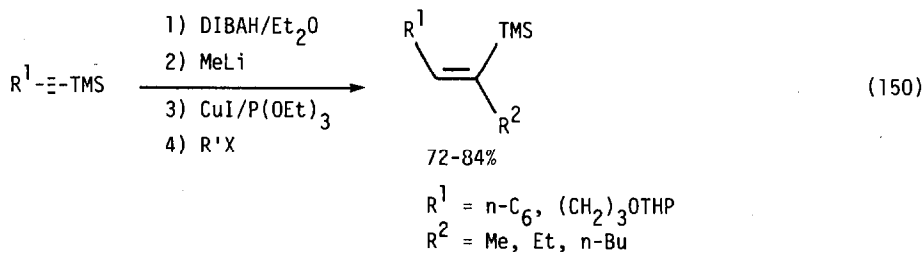
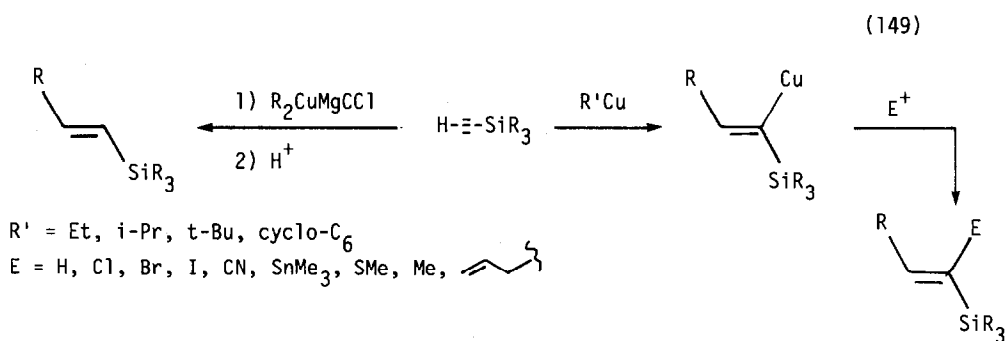

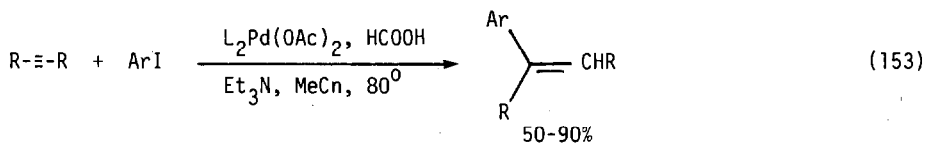

Palladium complexes catalyzed the arylation of alkynes by aryl iodides (equation 153) [161]. Terminal alkynes were alkylated to give internal alkynes by organic halides and a palladium(0)/copper(I) catalyst (equation 154) [162]. Zirconocene dichloride catalyzed the addition of allyl aluminum reagents to alkynes (equation 155) [163].

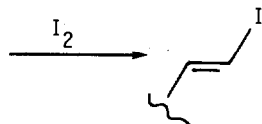
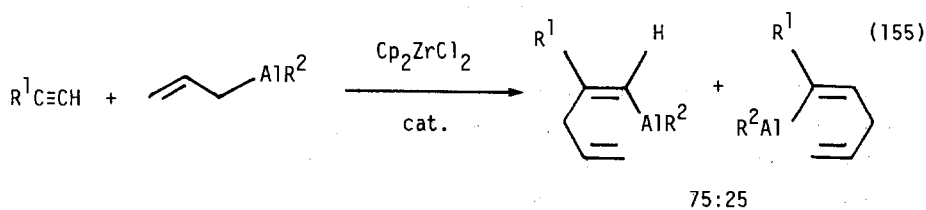
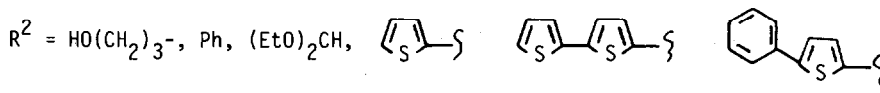
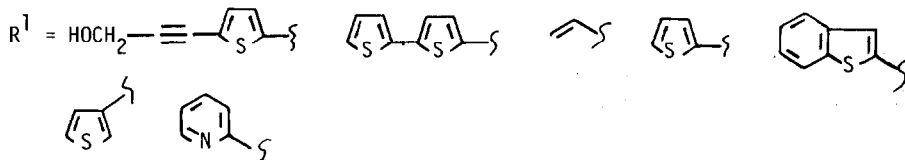
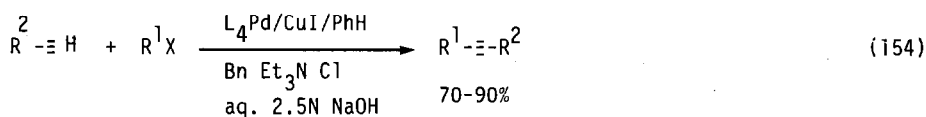

R = Ph

Ar = Ph, p-MePh, p-HOPh, p-MeOPh, m-NH<sub>2</sub>Ph, m-CONHMePh, p-CONHMePh, p-OHCNHCH<sub>2</sub>, 



R<sup>1</sup> = n-C<sub>6</sub>, Ph, TMS-C≡CCH<sub>2</sub>-, 

Iron-alkyne complexes were generally reactive towards organocopper reagents and stabilized carbanions, giving  $\sigma$ -vinyliron complexes (equation 156) [164]. Ruthenium iron and cobalt carbonyls catalyzed the addition of perfluoro halides to alkynes (equation 157) [165]. Chromium(II) catalyzed the intramolecular alkylation of alkynes by alkyl halides (equation 158) [166].

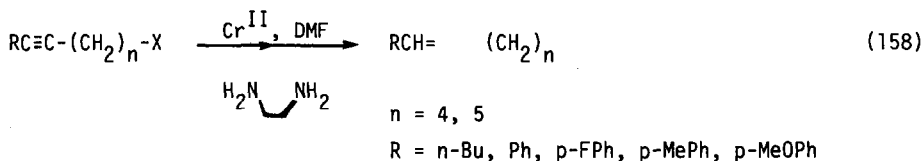
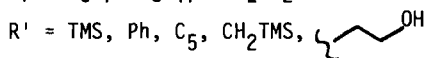
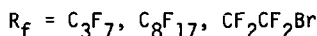
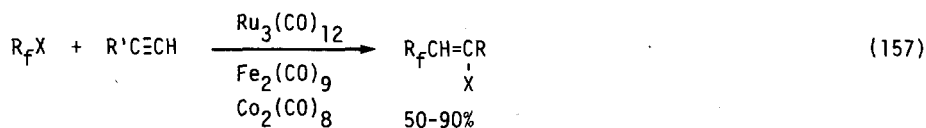
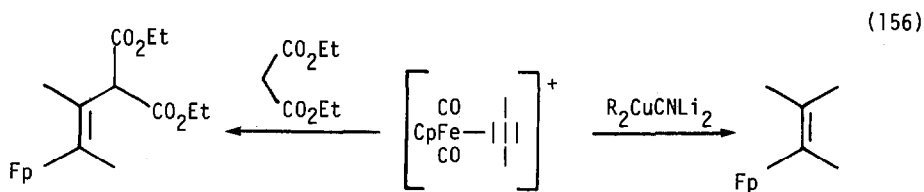

An organotransition metal approach to the synthesis of substituted naphtho- and benzoquinones was the topic of a dissertation [167]. Cobalt(I) complexes catalyzed the reaction of alkynes with cyclobutene diones to produce benzoquinones (equation 159) [168]. An intramolecular version of this reaction was used to synthesize naturally occurring naphthoquinones (equation 160) [169]. Cobalt complexed propargyl cations were alkylated cyclic ketones or trimethylsilylenol ethers (equation 161) [170]. Acetylenic alcohols were ethylated by ethyl aluminum compounds in the presence of titanium(IV) (equation 162) [171].

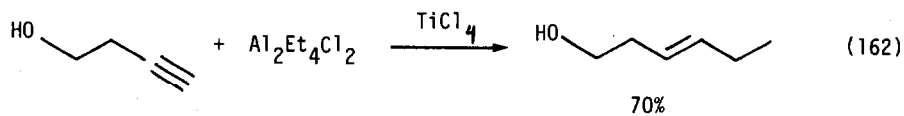
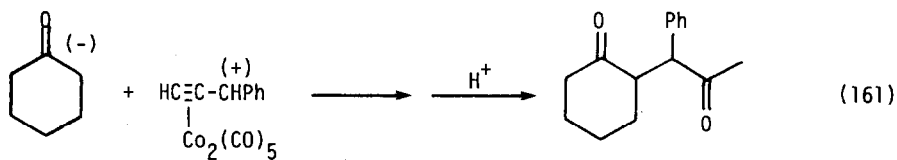
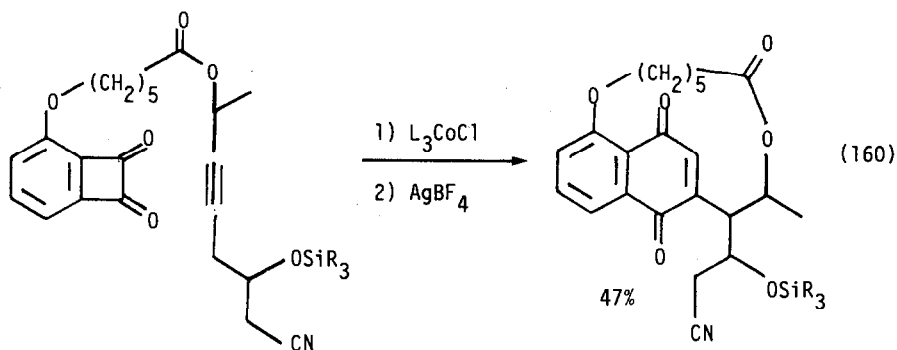
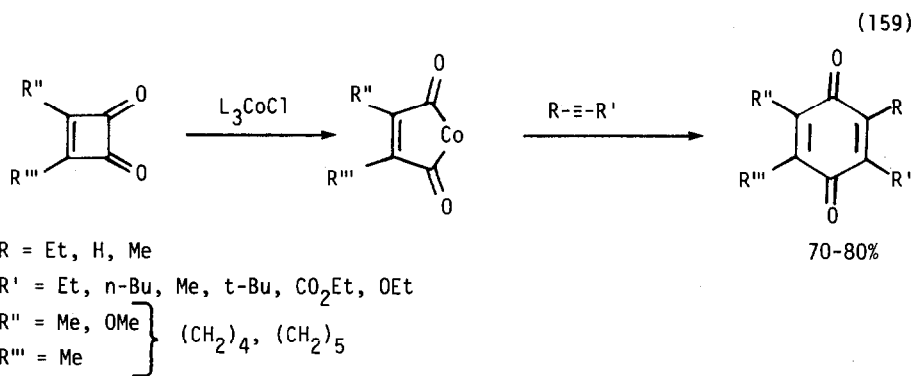

## 7. Alkylation of Allyl and Propargyl Alcohols and Acetates

The regiochemistry of the alkylation of allylic acetates by heterocuprates has been examined and has been shown to depend on the nature of both the cuprate and the substrate (equations 163-166) [172]. Copper(I)/BF<sub>3</sub> catalyzed addition of an aryl lithium to a cyclic allyl acetate went with clean S<sub>N</sub>2' chemistry (equation 167) [173], and was used to prepare cannabinoids. Dialkylcuprates opened allyl lactones to give mixtures of regioisomers (equation 168) [174]. Allyl carbonates and carbamates were also cleanly reduced by dialkylcuprates (equation 169) [175]. The alkylation of cyclopentylallylic lactones was used to synthesize d,1-iridomyrmecin [176]. Allylic acetals reacted with organocuprates by an S<sub>N</sub>2' process when unhindered, but by both S<sub>N</sub>2 and S<sub>N</sub>2' paths when hindered (equation 170) [177]. Dialkylcuprates alkylated allylnitro compounds (equation 171) [178]. Prostaglandins were synthesized by using the reactions of vinyl cuprates with cyclic allylic epoxides (equation 172) [179]. Propargyl halides were converted to allenes by organocopper reagents (equation 173) [180]. Carbocupration of acetylenic acetals and ketals-synthesis of α,β-ethylenic acetals, and of dienals and dienones - was the subject of a review (31 refernces) [181].

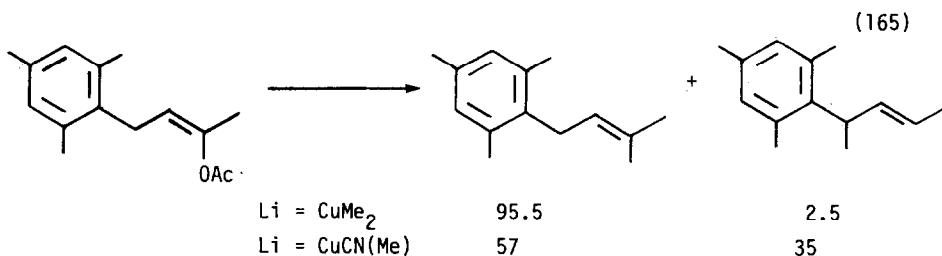
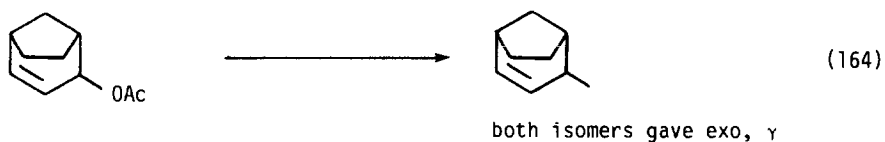
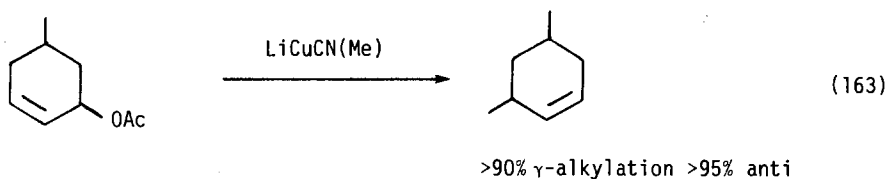

(166)

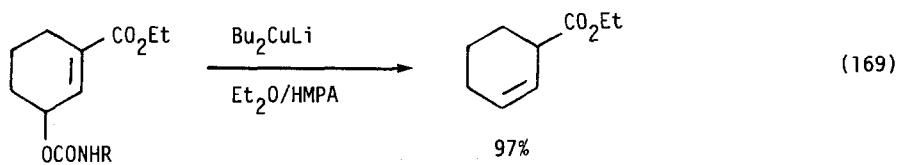
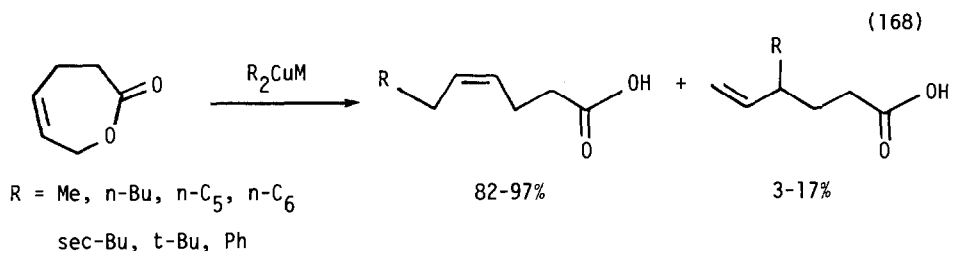
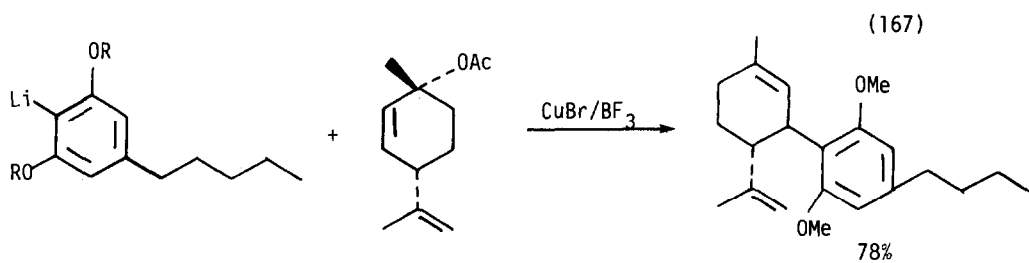
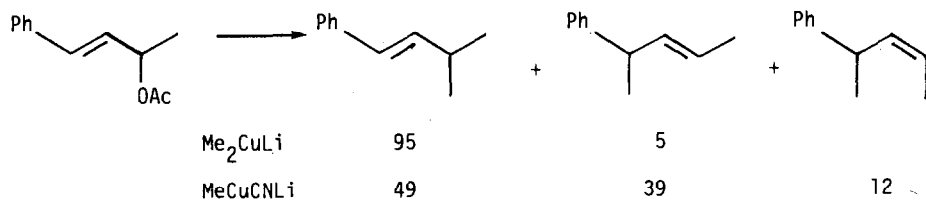

(169 continued)

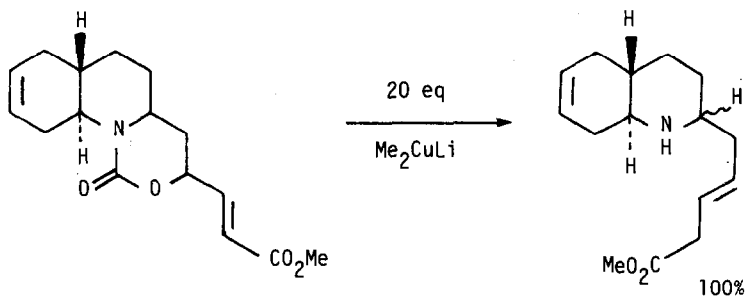

(170)

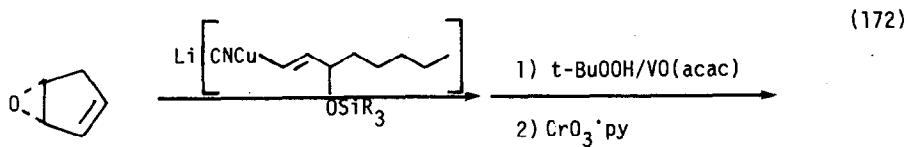
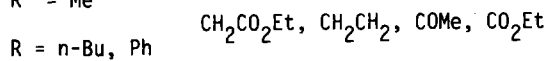
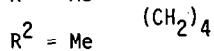
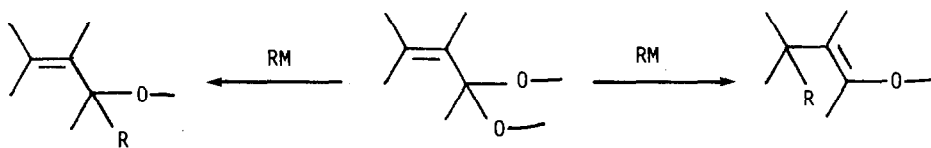

(continued on next page)



(172)

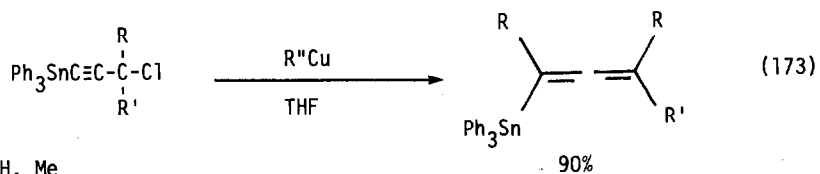
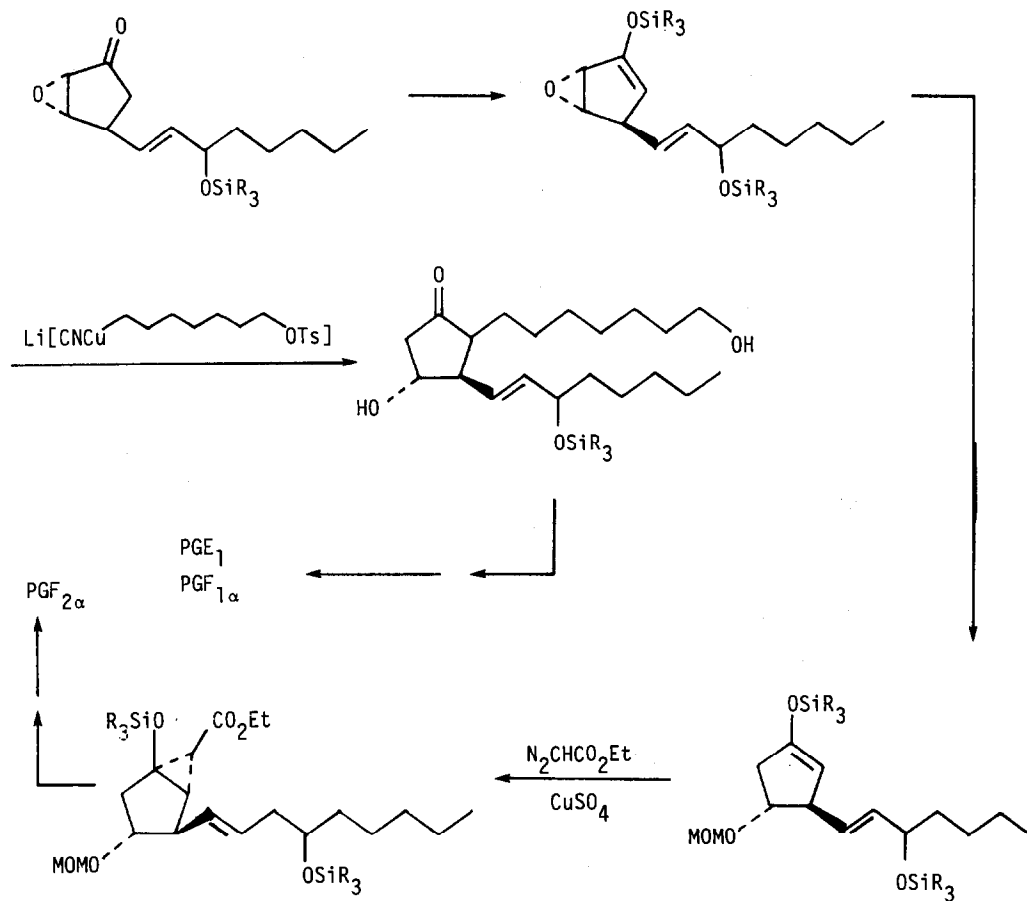

R, R' = H, Me

R'' = Et, Pr, i-Pr, Bu, t-Bu

R'' ≠ Me

Nickel(0) complexes catalyzed the alkylation of allyl acetates, tosylates and thiols by acetylenic Grignard reagents (equation 174) [182]. Nickel(II) phosphine complexes catalyzed the alkylation of allyl ethers by Grignard reagents (equation 175) [183]. Copper(I) iodide catalyzed the alkylation of allyl phosphates (equation 176) [184]. This chemistry was used to synthesize the African Monarch Sex Pheromone (equation 177). Palladium and nickel salts catalyzed the alkylation of allyl compounds by organozinc reagents [185].

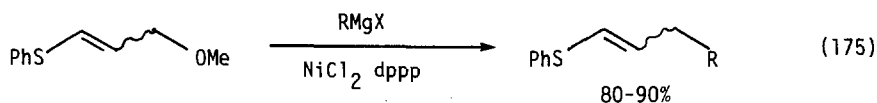
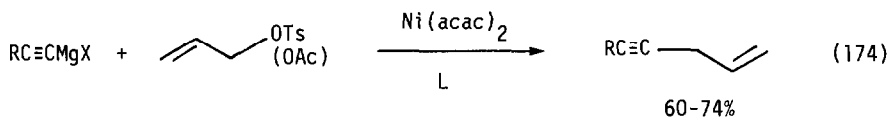

R = Ph, Me, Bu, n-C<sub>6</sub>, n-C<sub>8</sub>, Ph

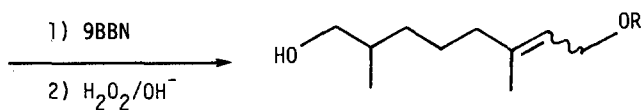
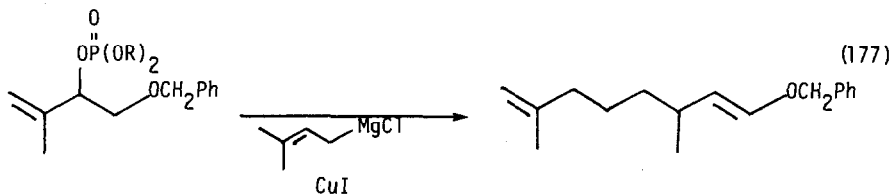
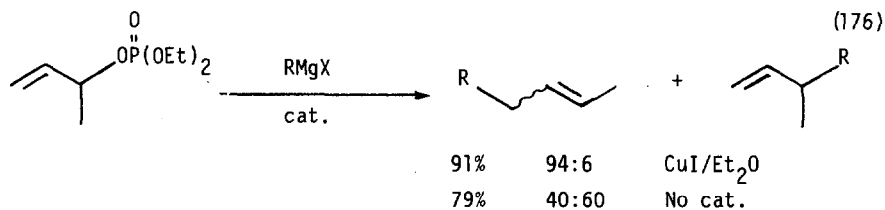

Palladium catalyzed reactions of nucleophiles with allylic substrates continues to be an active area of research. A review entitled "Organopalladium and - molybdenum intermediates - chemical chameleons", surprisingly deals with metal catalyzed alkylations of allylic substrates [186]. Asymmetric allylation with palladium or nickel complex catalysts have been reviewed (12 references) [187], as has new palladium-catalyzed reactions of allylic compounds via  $\pi$ -allylpalladium complexes [188]. A model for the regiochemistry of allylic alkylation using M.O. calculations has been developed. It concluded that palladium-catalyzed reactions were controlled by steric factors, that tungsten catalyzed reactions were controlled by electronic factors, and that molybdenum catalyzed reactions were in between these two extremes [189]. The mechanism of palladium-catalyzed allylic alkylation of allyl acetates (equation 178) concluded that the same regiochemistry was observed for both catalytic and stoichiometric reactions, and for neutral and cationic complexes. Acceptor ligands directed the attack to the more substituted position, and  $\eta^3$ -allyl not  $\eta^1$ -allyl complexes were involved [190].

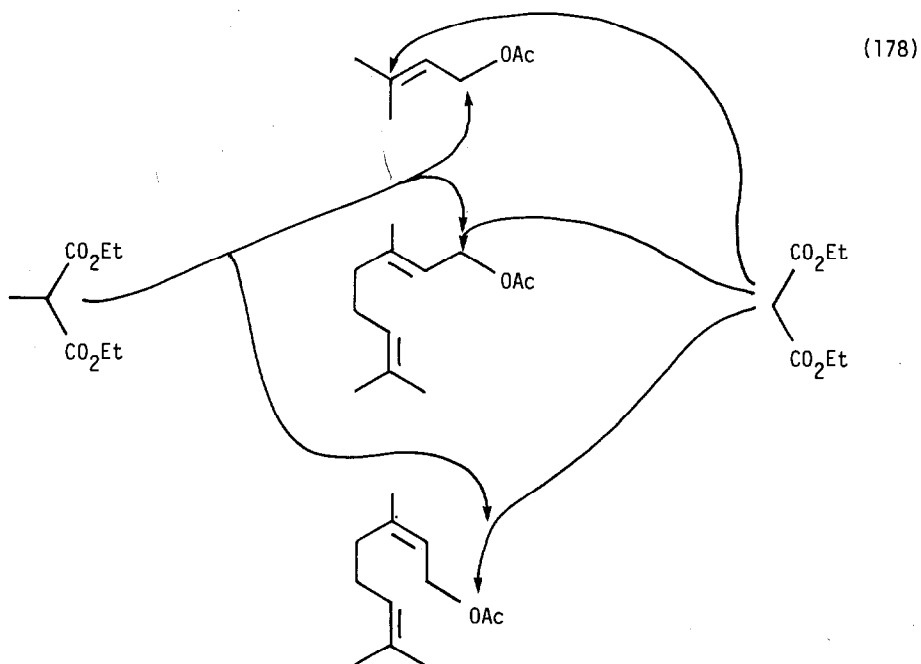

By coupling  $\omega$ -olefinic carbanions to unsaturated allyl acetates, a very efficient approach to polycyclic compounds has been developed (equations 179-183) [191].  $\alpha$ -Thio-allyl acetates underwent palladium catalyzed allylic alkylation to give regiochemistry opposite that of normal Michael addition processes (equation 184) [192]. Palladium catalyzed the alkylation of allyl acetates by tin enolates (equation 185) [194]. Allylic diacetates underwent palladium(0) catalyzed allylic alkylation by stabilized carbanions (equation 186) [195].

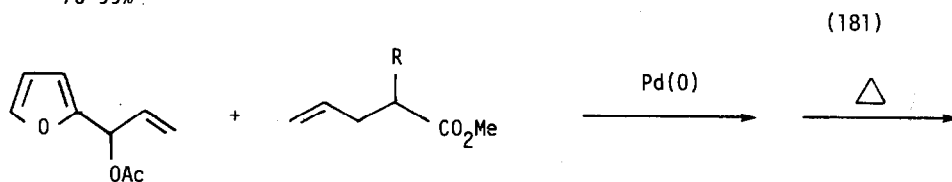
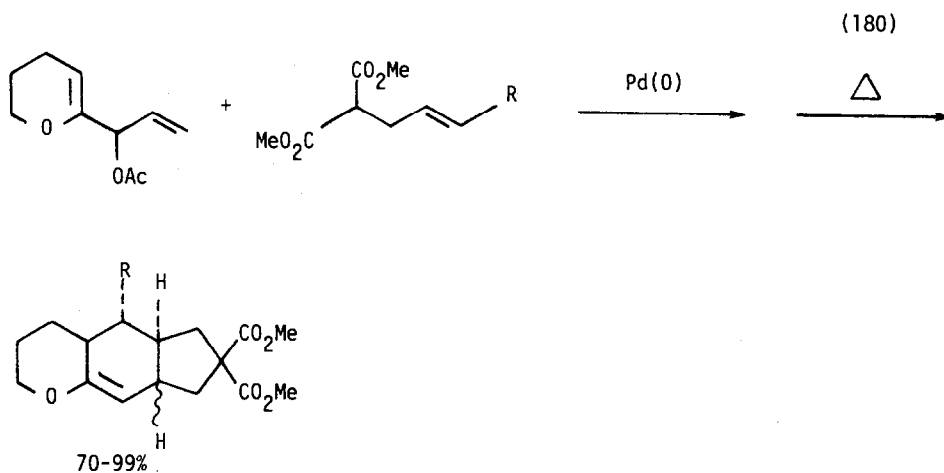
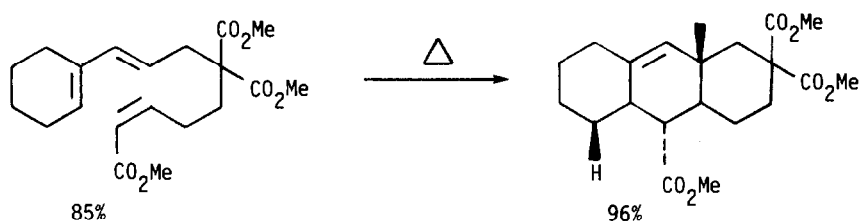
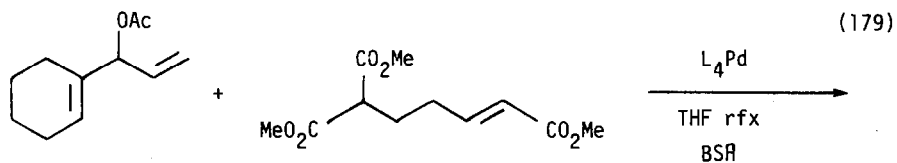

(181 continued)

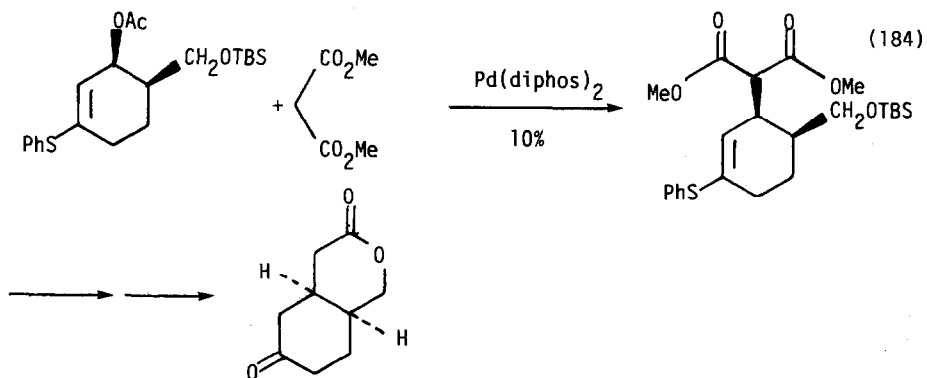
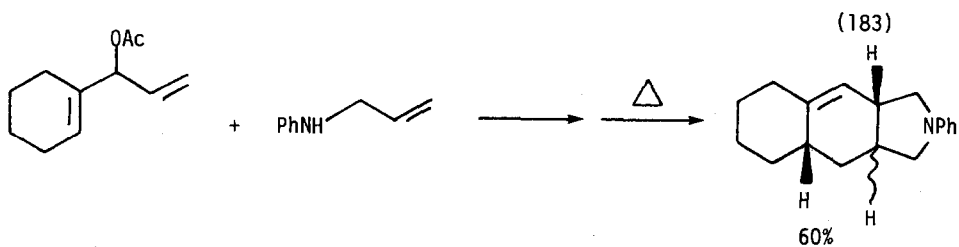
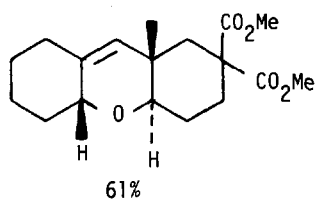
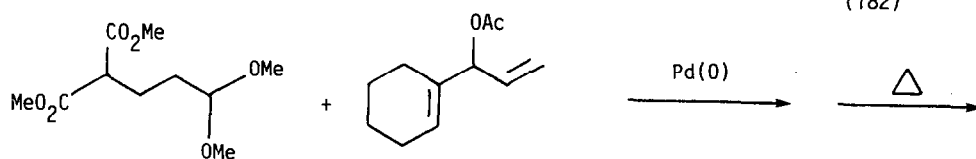
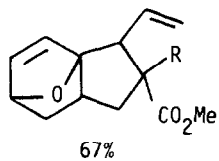

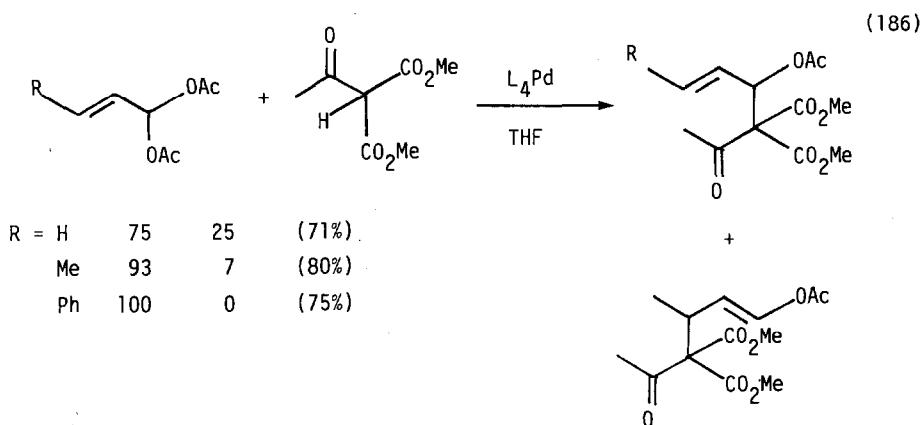
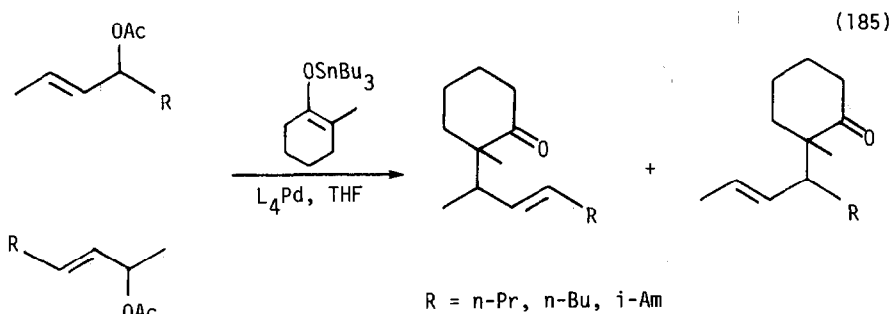

More highly functionalized allylic substrates also underwent palladium catalyzed allylic alkylation to give more functionalized products (equation 187) [195], (equation 188) [196], (equations 189-191) [197]. Allenic acetates underwent palladium catalyzed alkylation without rearrangement (equation 192) [198].

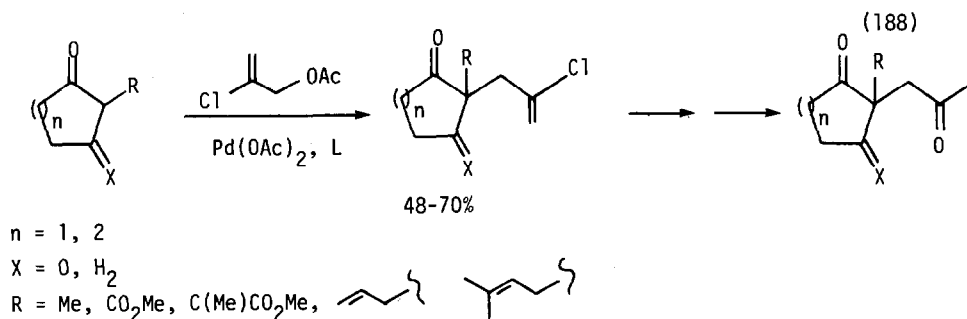

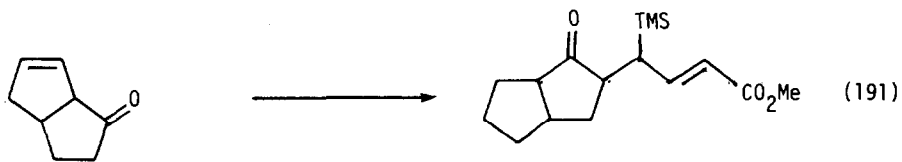
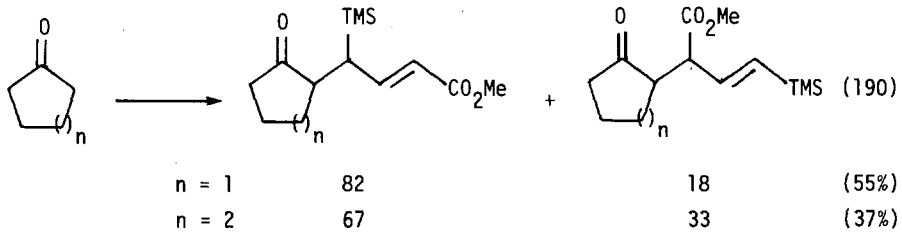
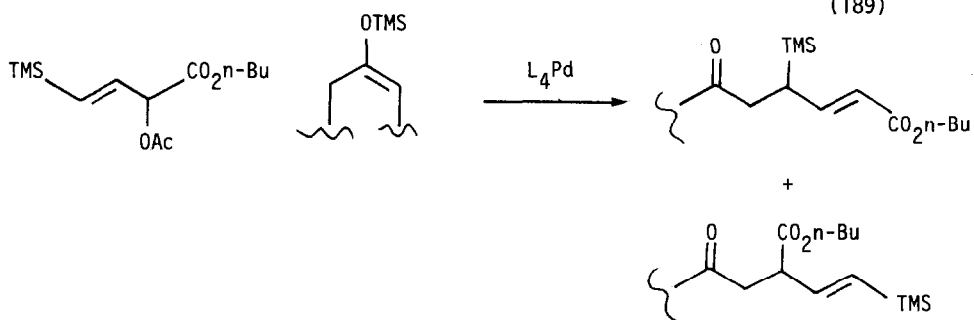
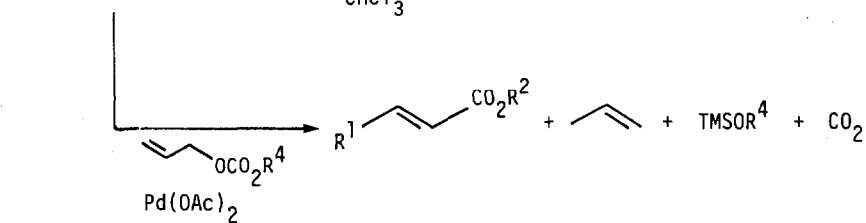
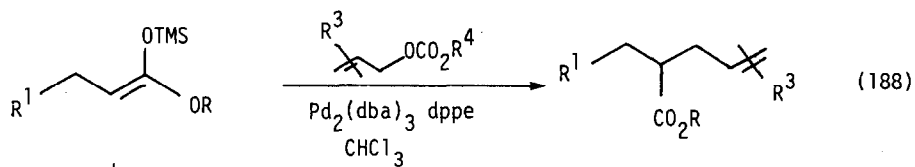

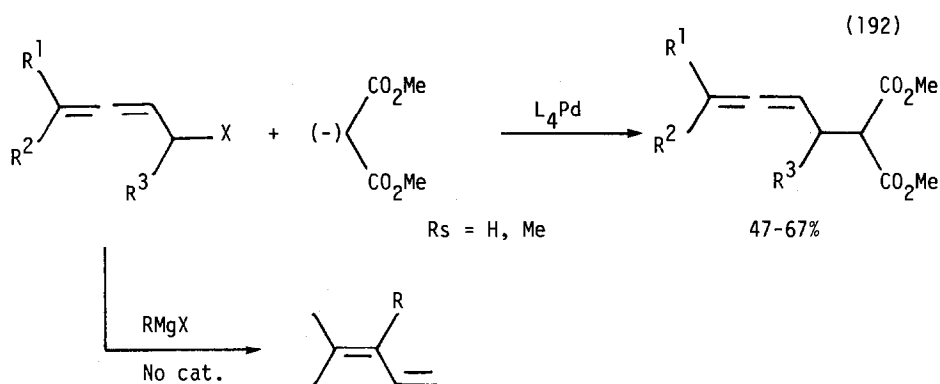

Chirality has been induced in intramolecular allylic alkylations of allyl carbonates when chiral starting materials were used (equation 193) [199], (equation 194) [200]. The palladium(0) catalyzed alkylation of allyl epoxides underwent a syn,  $S_N2'$  process in which an exclusive 1,4-syn relationship between the entering and departing groups was observed (equations 195 and 196) [201]. Allylic alcohols were alkylated by ketone enolates under palladium(0) catalysis, after conversion to their DCC adducts (equation 197) [202]. Dialkylation products were major.

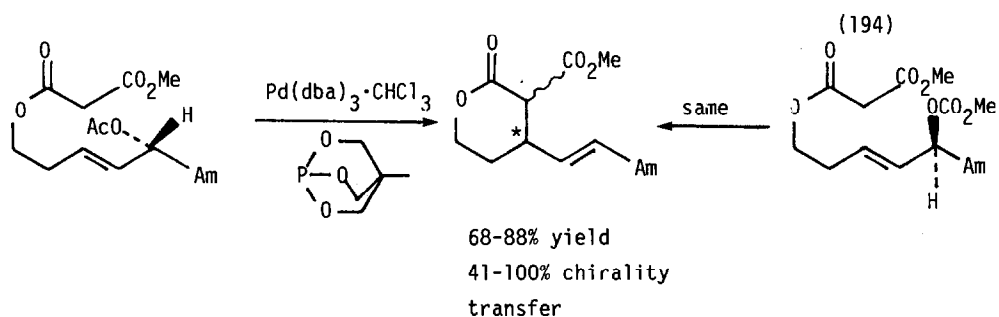
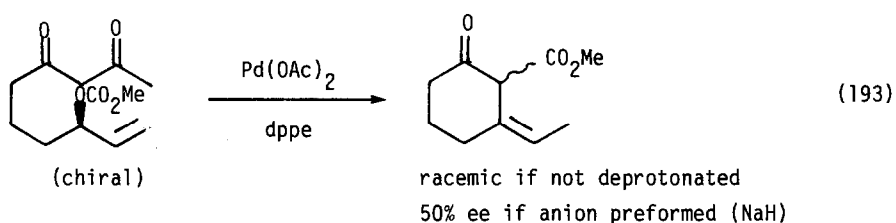



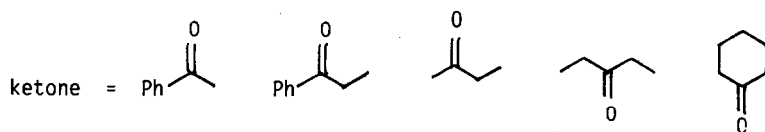
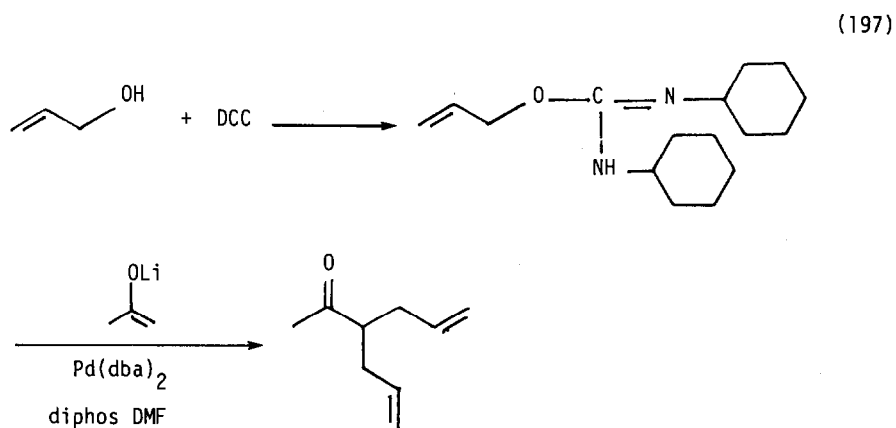
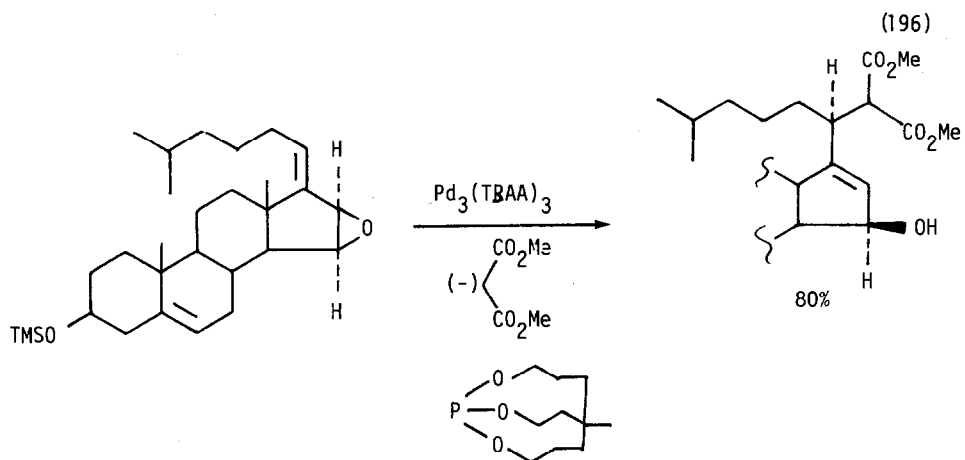
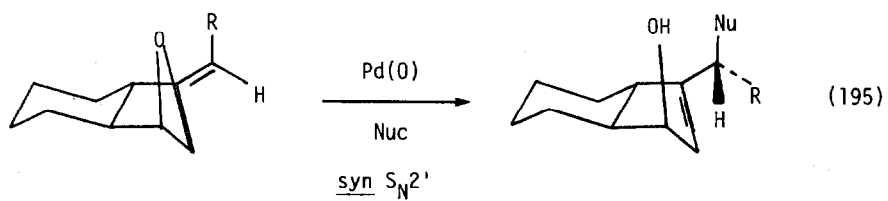

Chiral allyl sulfonates underwent palladium catalyzed allylic alkylation with a high degree of stereospecificity but low regioselectivity (equation 198) [203] [204]. Allyl acetates were converted to allyl stannanes by the palladium(0) catalyzed reaction with diethylaluminum stannane (equation 199) [205].  $\alpha$ -Nitro esters alkylated allyl acetates, ethers, and carbonates in the presence of palladium(0) catalysts (equation 200) [206]. Allyl acetates were made to react with electrophiles by conversion to the  $\pi$ -allylpalladium complex, followed by reduction (equation 201) [207].

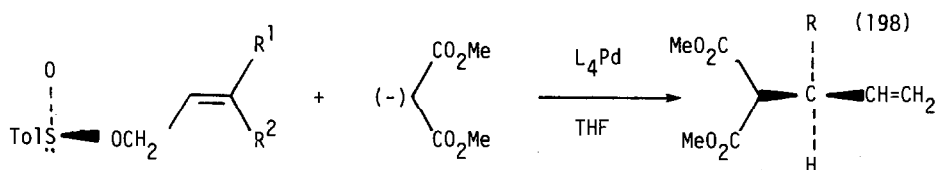

R <sup>1</sup>	R <sup>2</sup>	% Stereospecificity
Me	H	83
H	Me	78
n-Pr	H	33
H	n-Pr	21

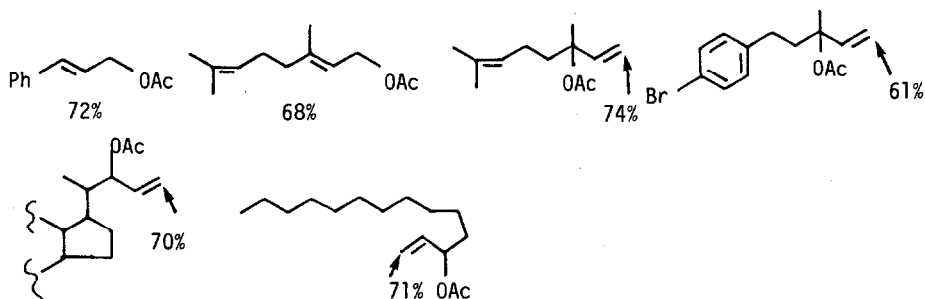
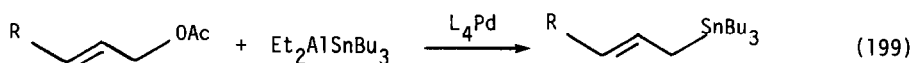
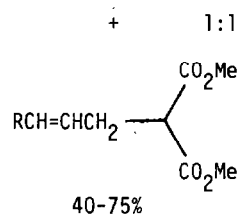

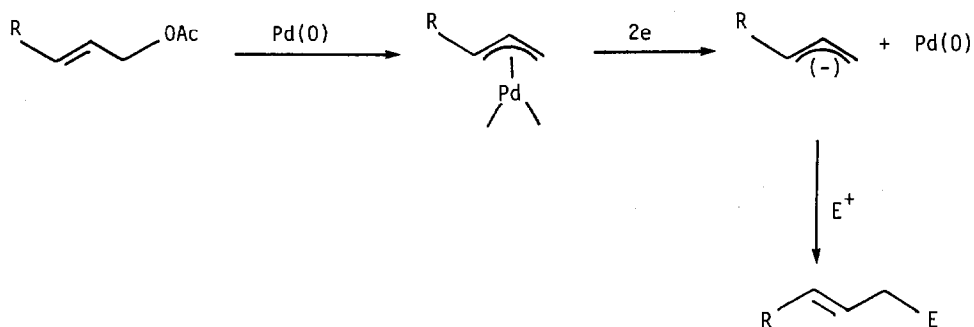
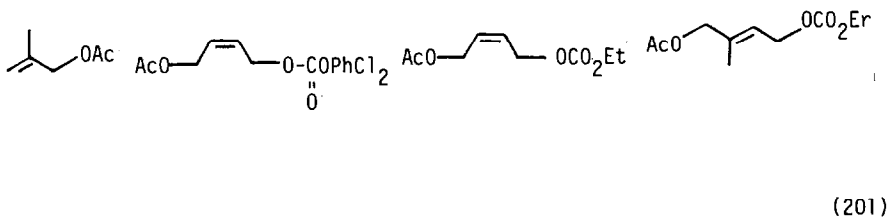
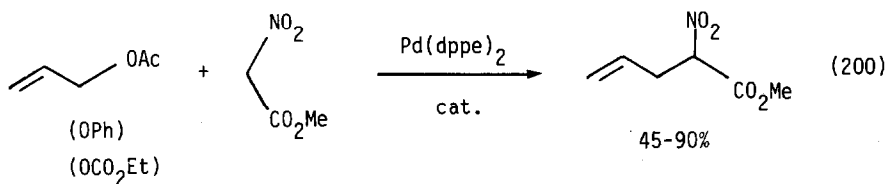

Molybdenum-mediated allylation of nucleophilic species was the topic of a dissertation [208]. Humulene was synthesized by the palladium(0) catalyzed cyclization of a vinyl borane with an allylic halide (equation 202) [209]. Rhodium(I) hydride complexes catalyzed the allylic alkylation of alkyl carbonates at the more substituted terminus (equation 203) [210]. Deuterated allyl alcohols were allylated to  $\alpha$  aryl ketones by aryl halides using palladium(0) catalysts (equation 204) [211]. Allyl silanes were alkylated by perfluorohalides in the presence of iron or ruthenium catalysts (equation 205) [212].

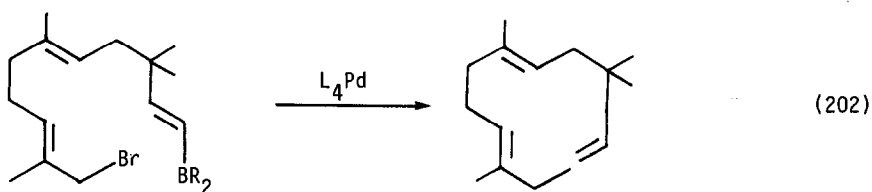

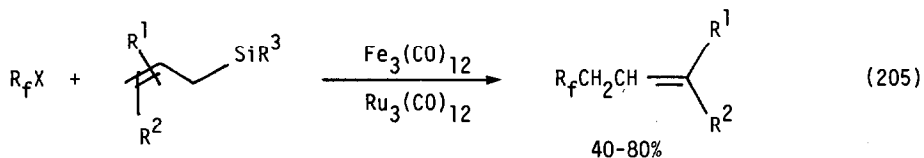
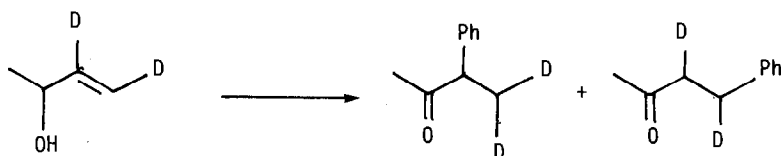
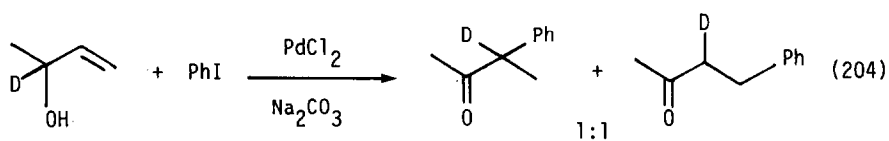
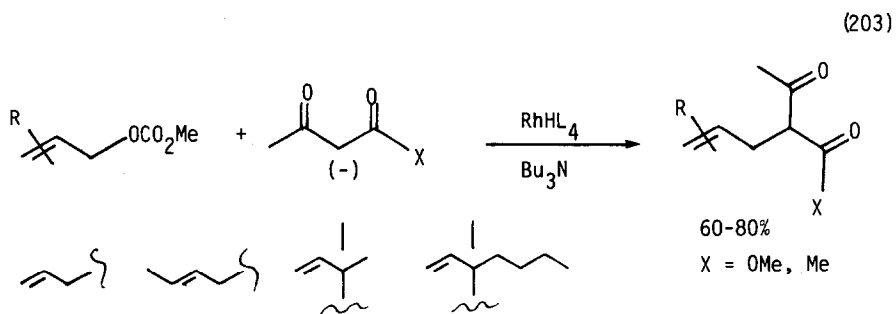

$R_f = \text{C}_3\text{F}_7, \text{C}_8\text{F}_7, \text{etc.}$

$R^1 = \text{H}; R^2 = \text{H, Me, CH}_2\text{CF}_3; R^3 = \text{Me, H}$

Cobalt stabilized propargyl cations were alkylated by ketone enolates (equation 206) [213] [214]. This was used in an annelation sequence (equation 207) [215].

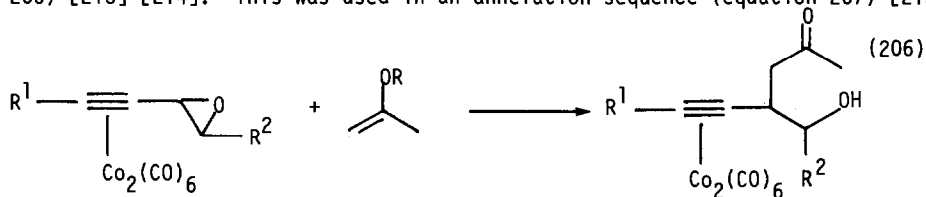

(207)

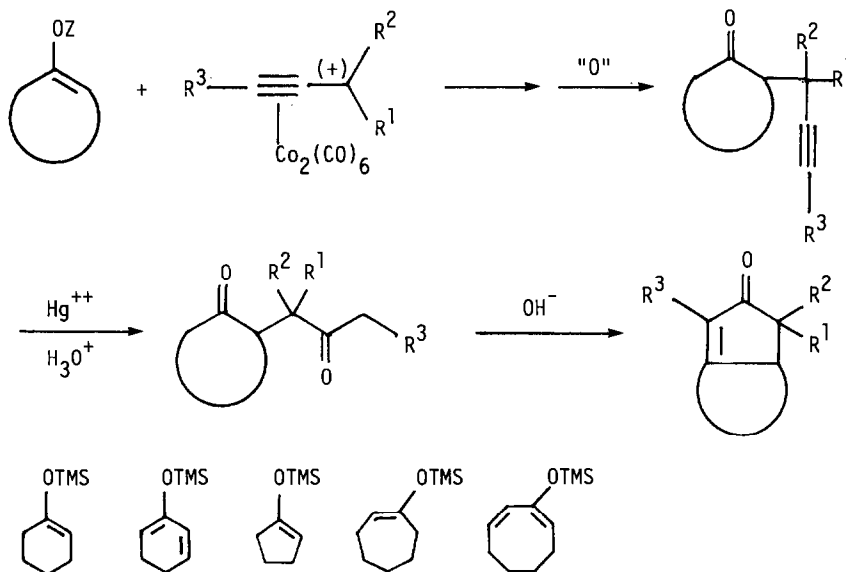

### 8. Coupling Reactions

Regioselectivity in metal-promoted carbon-carbon coupling reactions has been reviewed (32 references) [216]. Chloroquinones were coupled by catalysts containing nickel(0)/nickel(II) catalysts (equation 208) [217]. The electrocatalyzed coupling of allyl halides promoted by nickel-phosphine catalysts has been subjected to a mechanistic study [218]. Nickel(0) complexes coupled iodobenzophenones with chloropyrazines (equation 209) [219]. Halogenated pyridines and quinolines were coupled by nickel(II)/zinc catalysts (equation 210) [220]. Organocoppers as intermediates in the Ullmann biaryl synthesis was the topic of a dissertation [221]. Aryl, vinyl and heteroaryl halides were coupled by nickel(II) salts/zinc in DMF (equation 211) [222]. Chiral binaphthyls were synthesized by coupling, with copper/DMF, of naphthol esters of chiral diacids (equation 212) [223]. A "complex" reducing agent produced from nickel(II) acetate/sodium hydride/*t*-amylxide/bipyridine was an efficient catalyst for the coupling of aryl and vinyl halides (equation 213) [224].

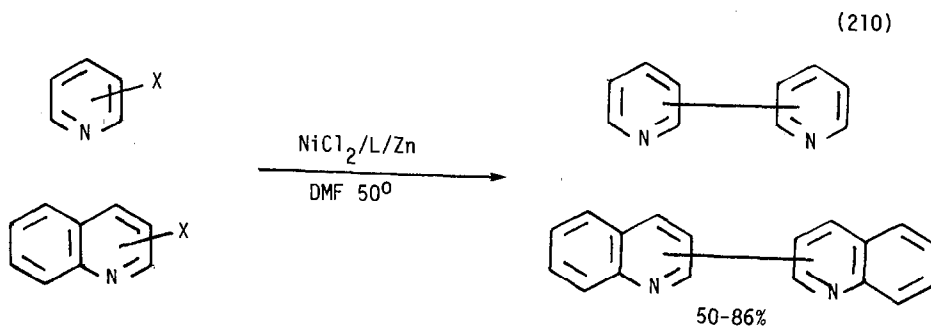
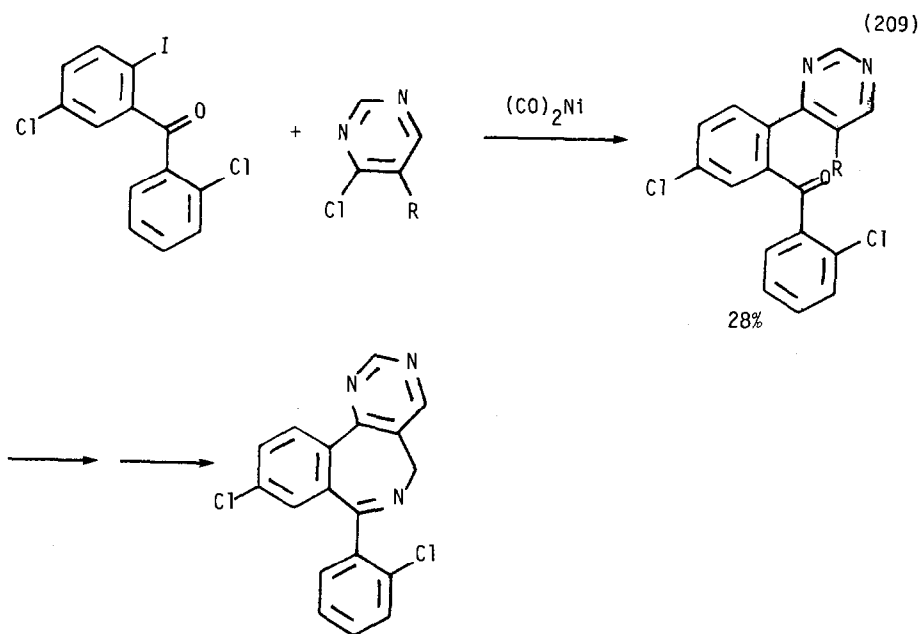
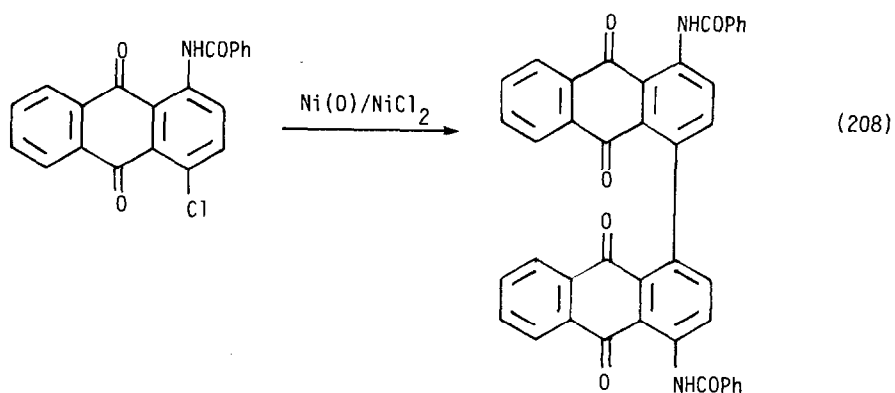

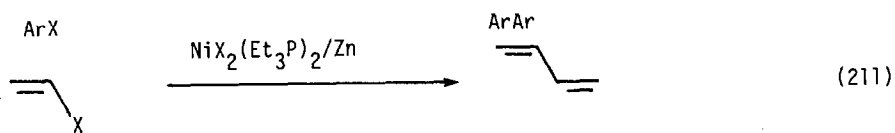

(212)

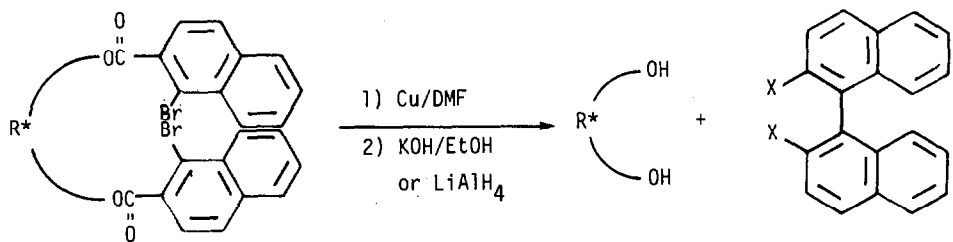
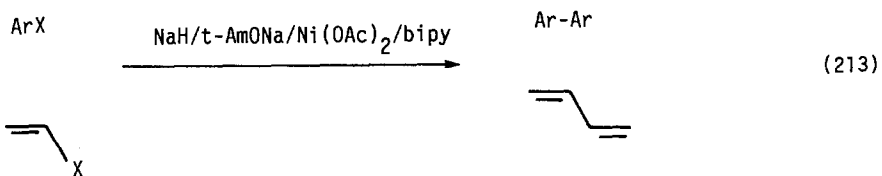
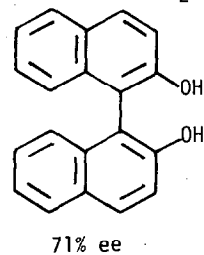
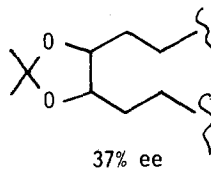
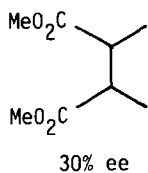
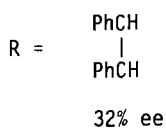
X = COOH, CH<sub>2</sub>OH

Ar = Ph, 1-naphth, 2-MeOPh, 4-MeOPh, 3-MeOPh, 2-MePh, 3-MePh, 4-MePh

also

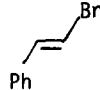
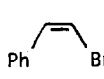
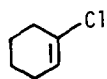
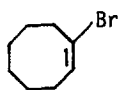

Active nickel metal, produced by the reduction of nickel(II) iodide by lithium/naphthalene, reductively coupled benzyl halides with  $\alpha$ -halonitriles (equation 214) [225]. The same reagent coupled benzyl halides to bibenzyls, with some competitive reduction (equation 215) [226]. Cobalt(I) complexes also coupled benzyl halides (equation 216) [227].

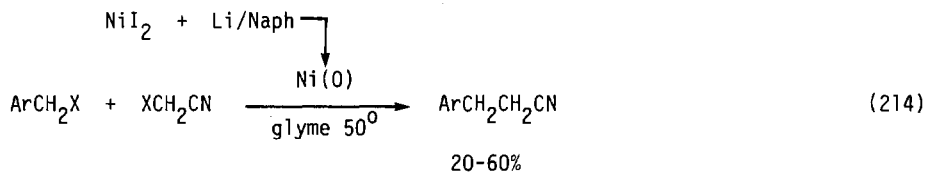

Ar = Ph, 4-MePh, 3-CF<sub>3</sub>Ph, 3-MeOPh, 4-FPh, 4-ClPh, 4-BrPh, 2-BrPh, 4-CNPh, 2-CNPh, 4-MeO<sub>2</sub>CPh, 1-Naphth, 2-Naphth

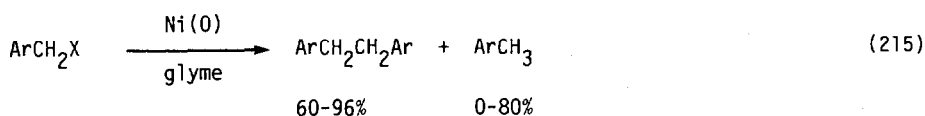

(Ar = same as equation 214)

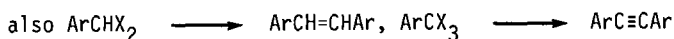
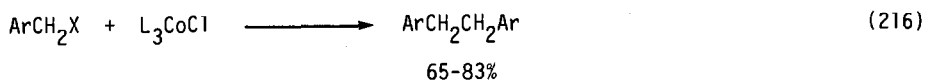
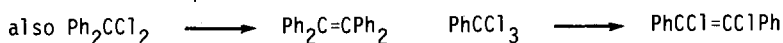

Vinyl halides were coupled to 1,3-dienes by nickel(II)/zinc/NaI (equation 217) [228].  $\alpha$ -Haloesters coupled to conjugated esters by lithium diisopropyl amide/copper(I) iodide (equation 218) [229]. Geminal vinyl dihalides were coupled to cumulenes by nickel(0) catalysts (equation 219) [230].

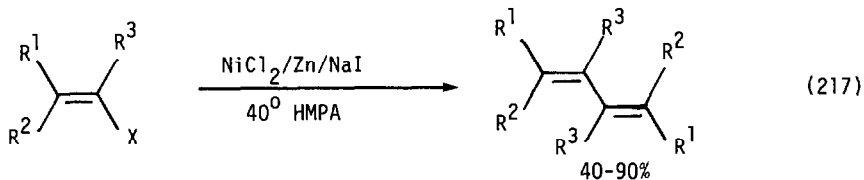

R<sup>1</sup> = Ph, Me, H, MeO<sub>2</sub>C  
R<sup>2</sup> = Ph, Me, H, p-ClPh  
R<sup>3</sup> = H, Me

(CH<sub>2</sub>)<sub>5</sub>, (CH<sub>2</sub>)<sub>6</sub>

mixed EE, EZ, ZZ



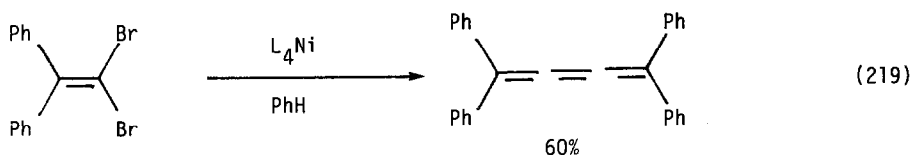
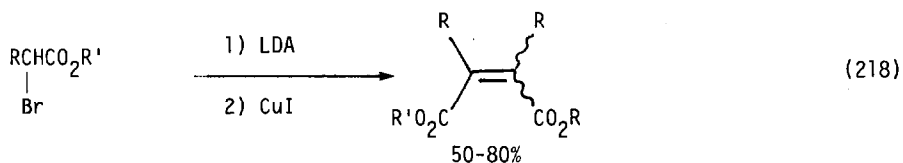

Heteroaromatic compounds were directly coupled by treatment with palladium(II) acetate in acetic acid (equation 220) [231], or by aluminum(III) chloride/copper(II) chloride in chlorobenzene (equation 221) [232]. Anthracene underwent dimerization at the 9 and 10 positions when treated with palladium(II) acetate (equation 222) [233]. Low molecular weight polyphenylene oxides were produced by the oxidative coupling of 2,6-dialkylphenols with copper(II) chloride KOH/pyridine catalysts [234].

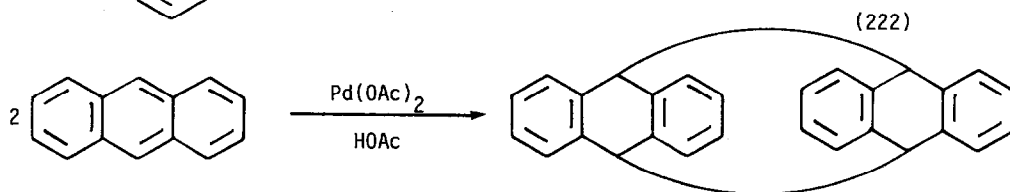
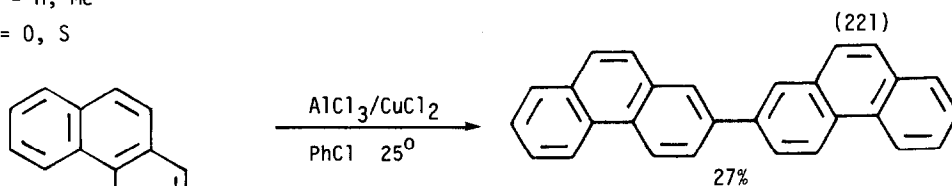
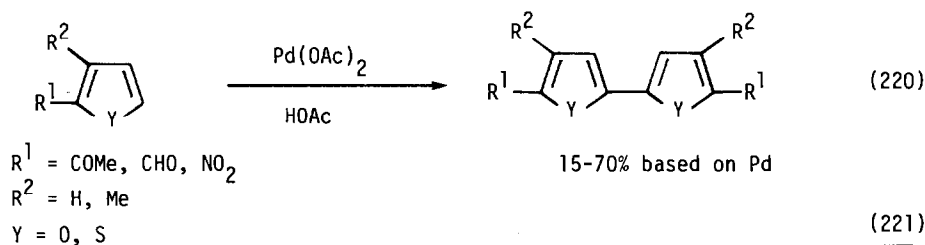

1,6-Dienes were coupled by palladium(II) or rhodium(I) catalysts to give cyclopentanes (equation 223) [235]. Palladium(II) acetate coupled propargyl acetates to dimers (equation 224) [236]. Alkynes were coupled to enynes by reduced titanium species (equations 225 and 226) [237].

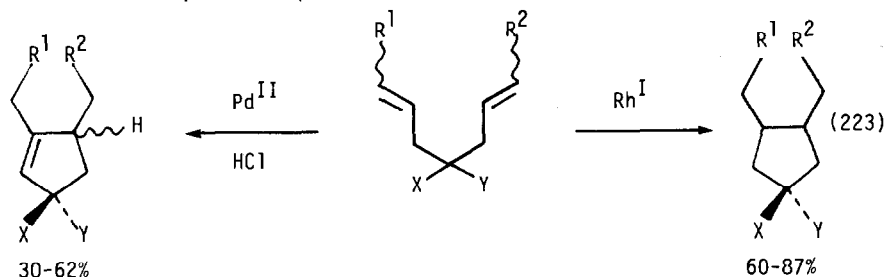

$R^1 = H, Me$

$X, Y = COMe, CO_2Me, CPh$

$R^2 = H, Me$

(224)

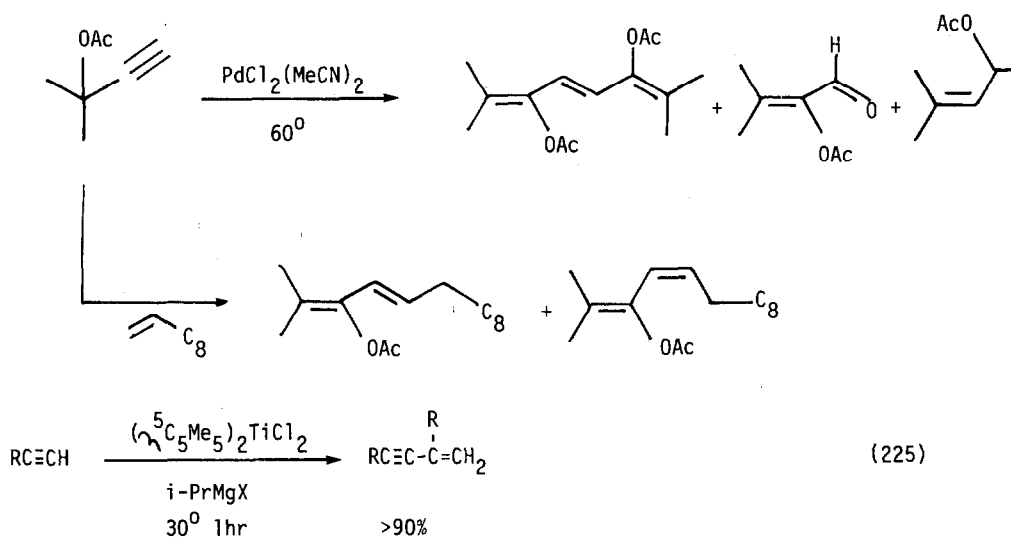

$R = Et, n-Pr, n-Bu, Ph, TMS, TMSCH_2, TMSOCH_2$

fails:  $R = t-Bu, EtO, EtS, Et_2N,$

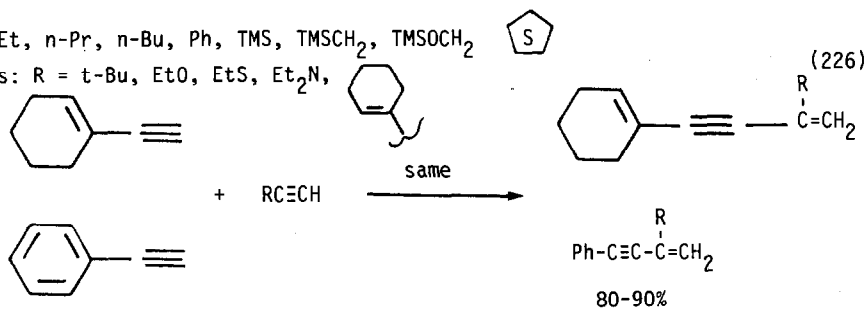

Low valent titanium reductively coupled aryl aldehydes to diaryl olefins and pinacols. Aliphatic aldehydes and ketones were reduced to alcohols (equation 227) [238]. Highly strained olefins were prepared in low yield by titanium(0) coupling of branched ketones (equation 228) [239]. Intramolecular versions of this coupling have also been performed (equation 229) [240], (equation 230) [241]. Tungsten complexes also coupled ketones and aldehydes to olefins (equation 231) [242], (equation 232) [243].

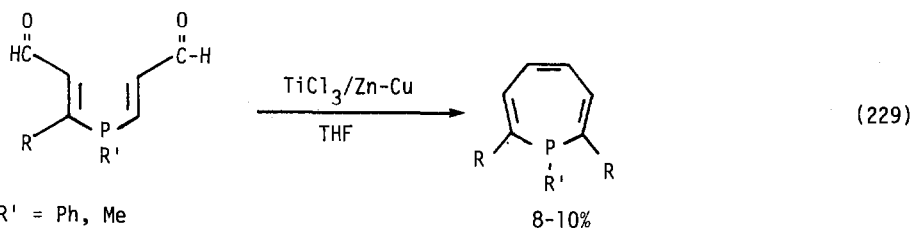
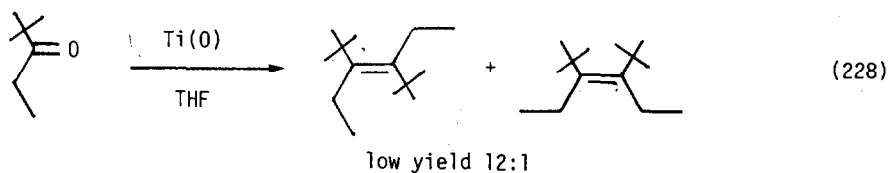
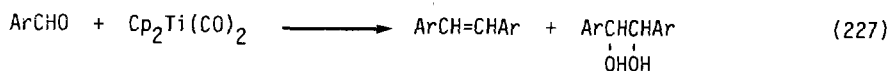

R' = Ph, Me

R = t-Bu, Ph

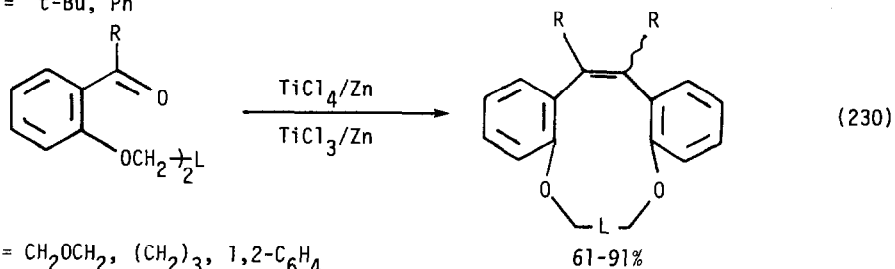

L = CH<sub>2</sub>OCH<sub>2</sub>, (CH<sub>2</sub>)<sub>3</sub>, 1,2-C<sub>6</sub>H<sub>4</sub>

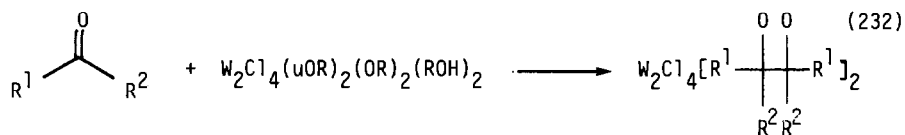
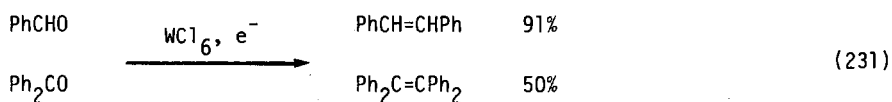

R<sup>1</sup> = Me

R<sup>2</sup> = Me, Et, n-Pr

### 9. Alkylation of $\pi$ -Allyl Complexes

The regiochemical studies of formation of allylpalladium complexes from olefins and palladium(II) salts was the topic of a dissertation [244], as was the stereochemical nature of the formation of  $\pi$ -allylpalladium complexes from olefins [245]. Allylic halides were converted to  $\pi$ -allylpalladium(II) halides in high yield by treatment with palladium black and ultrasound [246].  $\pi$ -Allyl palladium complexes from 2-methyl and 2,3-dimethyl-1,3-butadiene were subjected to a thorough <sup>1</sup>H nmr spectral study [247]. Nmr studies of reactions of a norbornyl  $\pi$ -allylpalladium complex with phosphine were carried out (equation 233) [248]. It was concluded that ion pairs formed in chloroform but not in THF, and that the regiochemistry of the reaction was unaffected by phosphine. Steroidal  $\pi$ -allylpalladium complexes were alkylated by stabilized carbanions in dry DMSO (equation 234) [249].  $\pi$ -Allylpalladium complexes coupled with allyl Grignard reagents to give unsymmetrical biallyls. Maleic anhydride was required to drive the reductive elimination (equation 235) [250]. A three-topic dissertation dealing with (1) a palladium catalyzed route to spirocycles; (2) sequential  $\pi$ -allylpalladium alkylations; and (3) the synthesis and chemistry of bridgehead olefin-metal complexes has appeared [251].

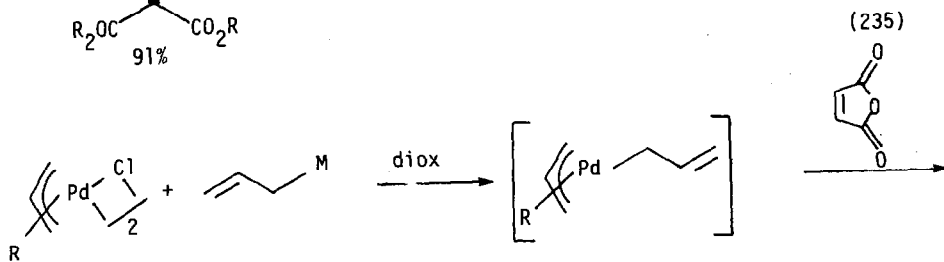
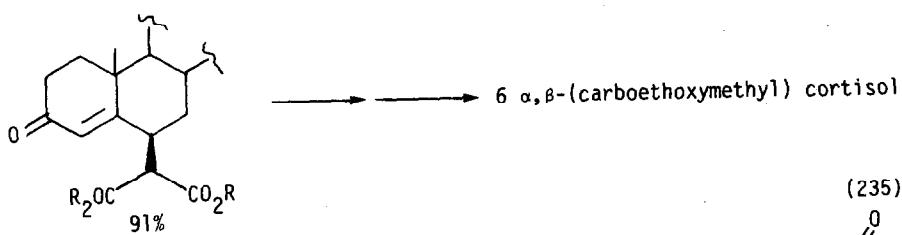
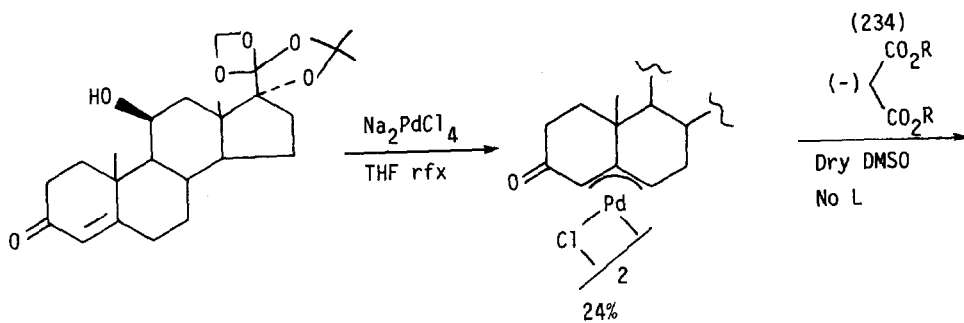
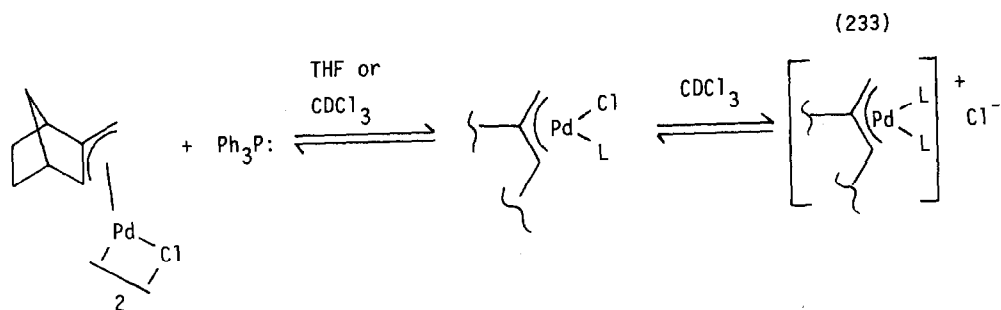

(235 continued)

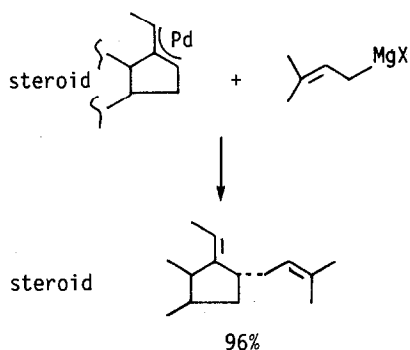
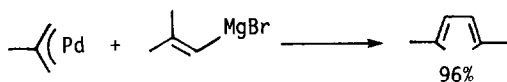
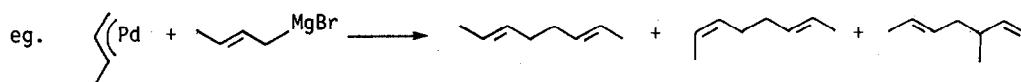

#### 10. Alkylation of Carbonyl Compounds

Some recent advances in the use of titanium reagents for organic synthesis has been reviewed (42 references) [252], as has carbon-carbon bond formation reactions using titanium reagents (40 references) [253]. Low valent titanium in organic synthesis: mechanisms of reductive coupling of ketones was the topic of a dissertation [254]. Ketones were alkylated by  $\alpha$ -halo ketones when treated with titanium (IV) chloride/zinc (equation 236) [255].

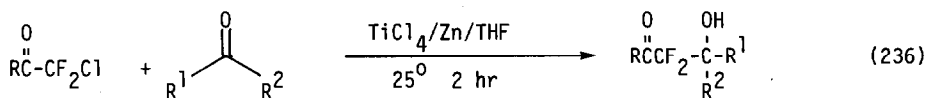

40-70%

R = n-C<sub>6</sub>, cyclo-C<sub>6</sub>, Me, PhCH<sub>2</sub>

R<sup>1</sup> = n-Pr, n-C<sub>6</sub>, i-Pr, Et, Me, cyclo-C<sub>6</sub>

R<sup>2</sup> = H, Et, (CH<sub>2</sub>)<sub>2</sub>CO<sub>2</sub>Et, (CH<sub>2</sub>)<sub>3</sub>CO<sub>2</sub>Et

Aldehydes were alkylated with low asymmetric induction by allyltitanium reagents chiral at the metal center (equation 237) [256]. Allyltitanium reagents alkylated aldehydes with high erythro:threo selectivity (equation 238) [257]. Boron trifluoride reversed this selectivity. Cyclic allyl titanium reagents alkylated aldehydes with exclusive erythro selectivity (equation 239) [258]. Allyllithium reagents alkylated aldehydes to give exclusively  $\alpha$ -adducts in the presence of titanium(IV) isopropoxide (equation 240) [259]. Aldehydes were converted to dienes when treated with vinyl silanes and titanium(IV) isopropoxide (equation 241) [260]. Propargyl titanium reagents alkylated aldehydes and ketones (equation 242) [261], (equation 243) [262]. This was used to synthesize asperlin (equation 244) [263].

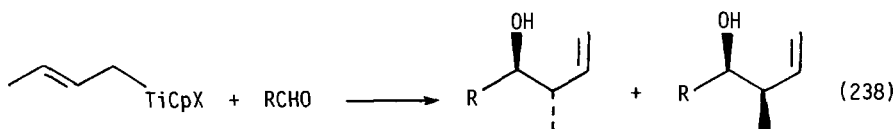
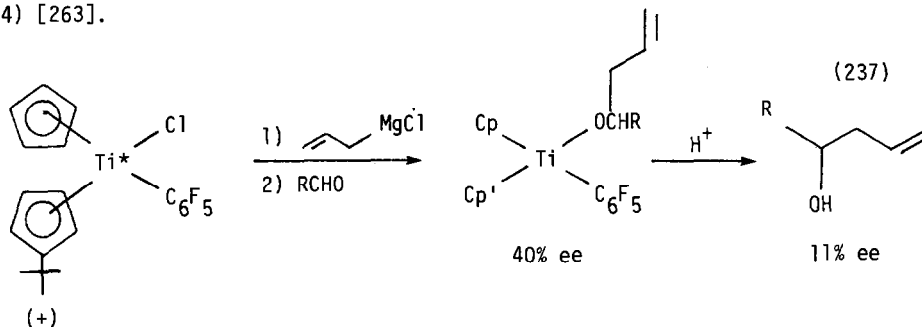

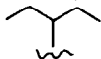
R=Ph, n-C<sub>6</sub>, i-Pr, 

BF<sub>3</sub> added      6:94 threo:erythro  
no BF<sub>3</sub>      100:0 threo:erythro

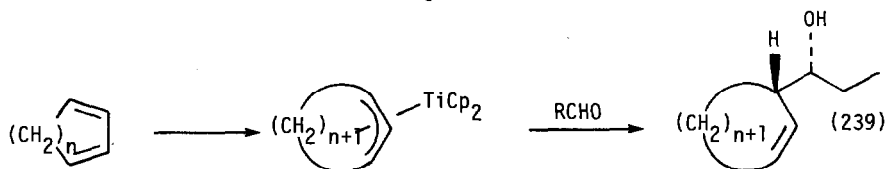

n = 3, 4, 5, 6, 10

70-86% erythro only

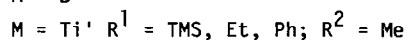
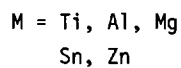
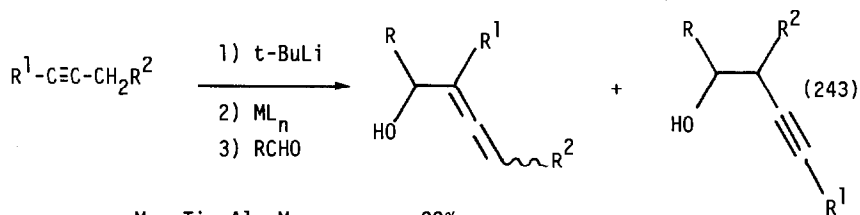
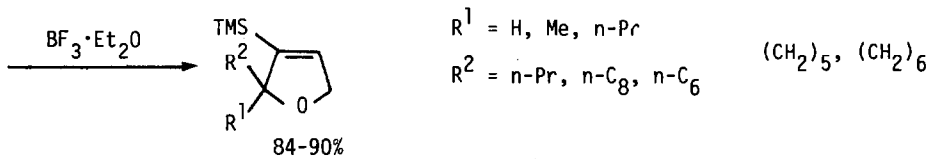
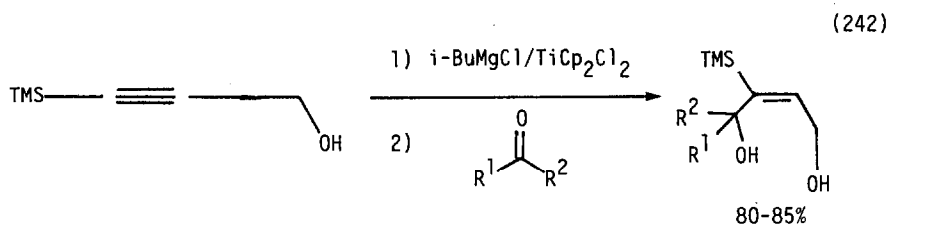
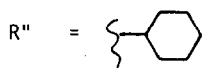
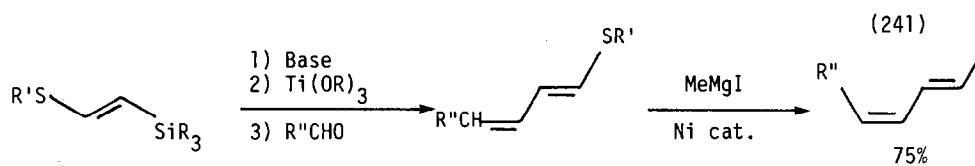
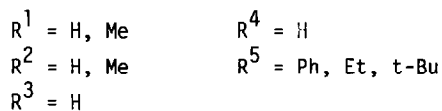
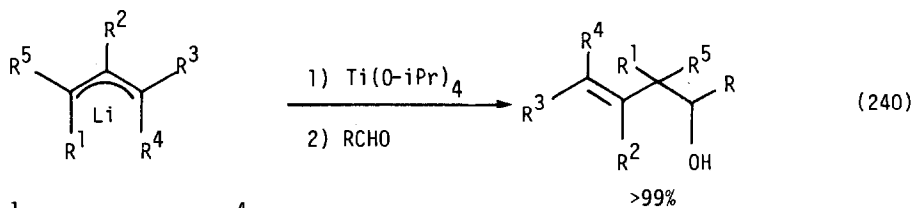



(243 continued)

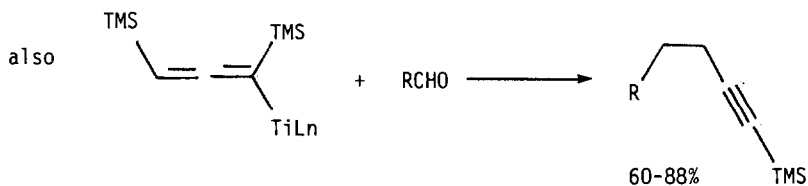

(244)

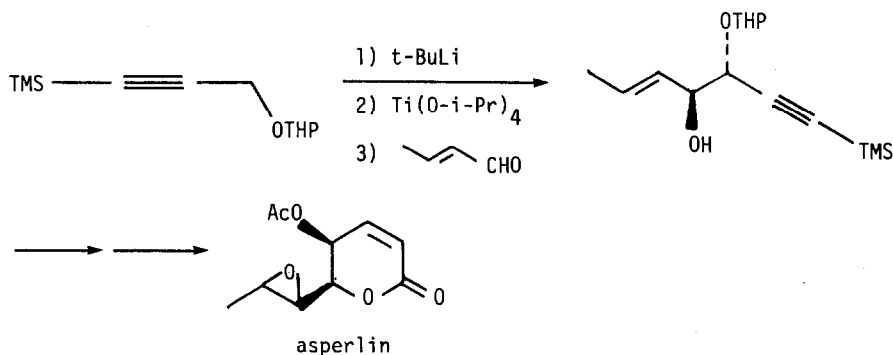

First row transition metal salts, in the presence of L- or D- tyrosine, catalyzed crossed aldol condensations of acetone and aromatic aldehydes to give optically active condensation products [264]. Ketone enolates alkylated titanium (IV) salts of aminals to give  $\beta$ -aminoketones (equation 245) [265]. Titanium(IV) chloride was used to convert acetals into heterocycles (equations 246 and 247) [266]. Ketones were converted to  $\beta$ -hydroxy thioamides in a titanium(IV) assisted process (equation 248) [267]. Chiral alcohols were synthesized by the reaction of organolithium or magnesium reagents with ketals or acetals of chiral diols in the presence of titanium(IV) (equation 249) [268], (equation 250) [269], and (equations 251 and 252) [270].

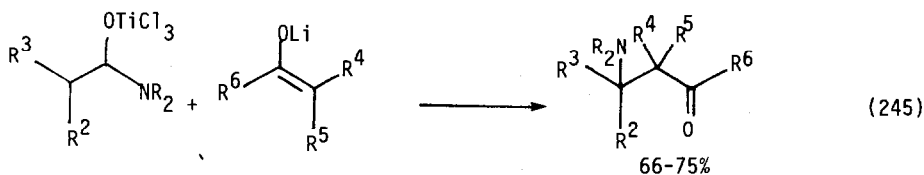

$R = (\text{CH}_2)_5, (\text{CH}_2)_2\text{O}(\text{CH}_2)_2, \text{Me}, \text{Et}, \text{PhCH}_2$

$R^3 = \text{H}$

$R^2 = \text{Ph}, p\text{-MeOPh}, 2\text{-naphth}, p\text{-BrPh}$

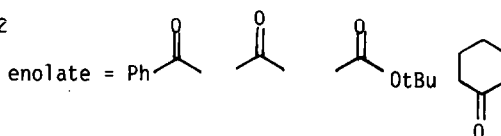

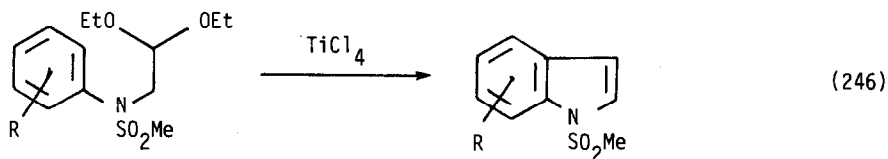

R = H, 4-Me, 4-OMe, 4-Br, 3-Me, 3-OMe  
60-80%  
3-Cl, 2-Me; 3-OMe, //, 2-OMe, 2-F, 2-Me all failed

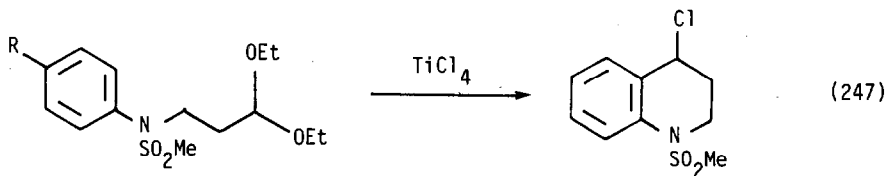

R = H, Me, OMe  
60-80%

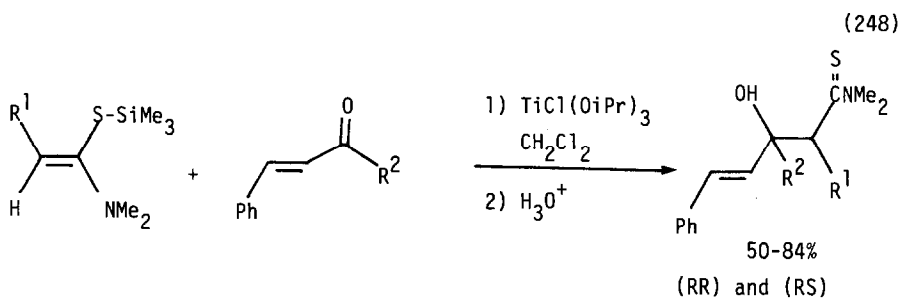

50-84%  
(RR) and (RS)

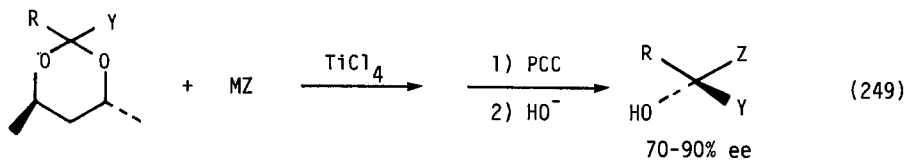

Y = H, Me  
Z = Me, n-Bu,  
M = Li, MgBr

70-90% ee

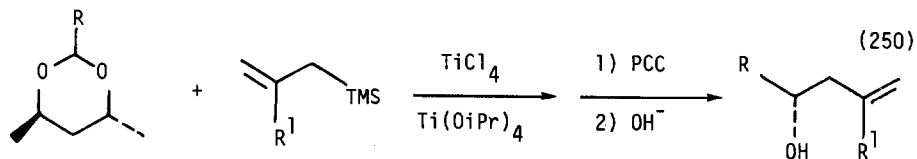

R = n-C<sub>8</sub>, , , i-Pr  
R<sup>1</sup> = H, Me

92-98% yield  
90-98% ee

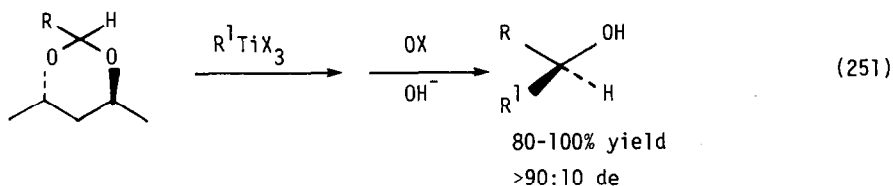

R = , n-C<sub>6</sub>, n-Bu, Me, Et

R<sup>1</sup> = Me, n-Bu, Et

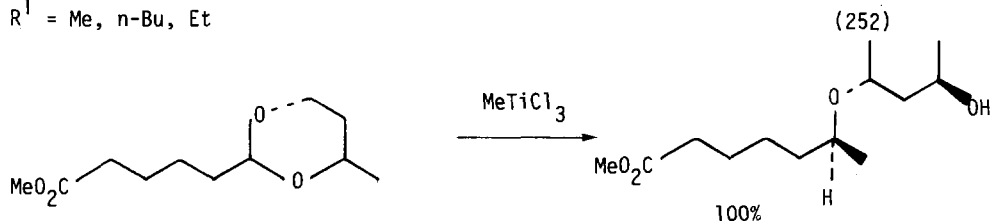

Tebbe's reagent efficiently converted enolizable ketones to methylenes (equation 253) [271]. It was used to convert a lactone to a cyclic allyl ether (equation 254) [272]. A facile preparation of Tebbe's reagent has been described [273]. Zirconium methylene reagents also converted ketones and imines to olefins. The E/Z ratio was determined by the size of the heteroatom substituent (equations 255 and 256) [274]. Molybdenum methylene reagents converted aldehydes to olefins and were stable in aqueous ethanol (equation 257) [275]. The chemistry of these molybdenum reagents depended on their mode of preparation (equation 258) [276]. Alkyl chromium reagents alkylated aldehydes even in the presence of large amounts of water or ethanol (equation 259) [277].

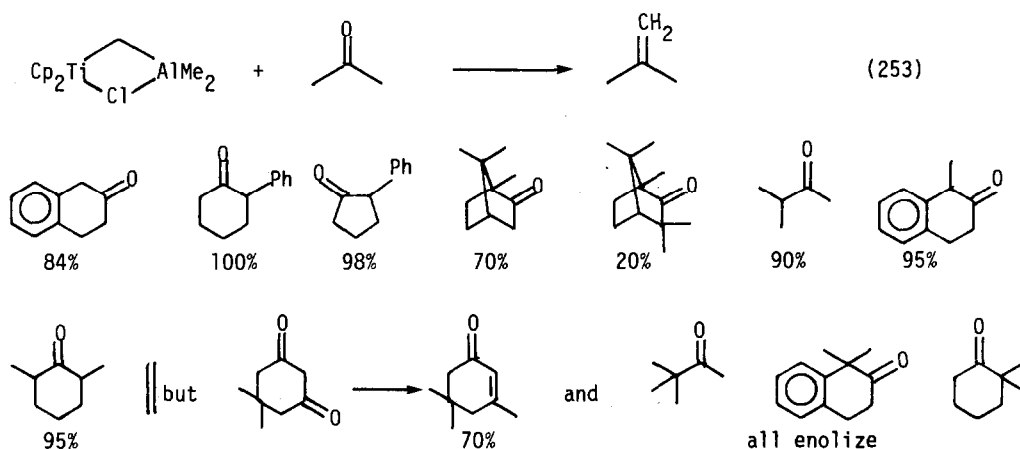

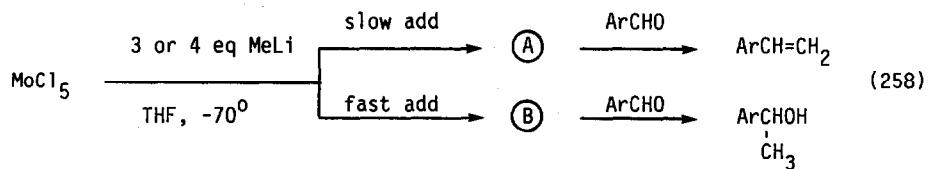
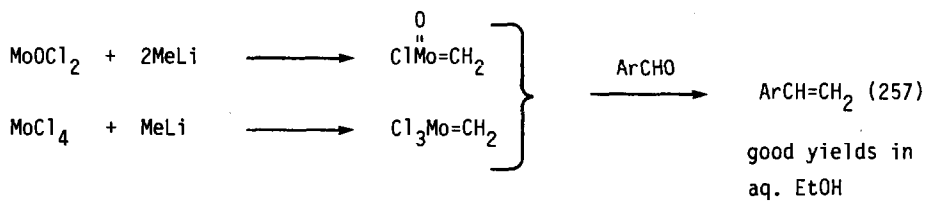
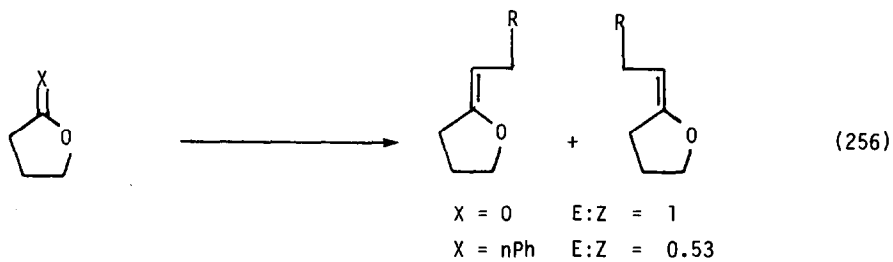
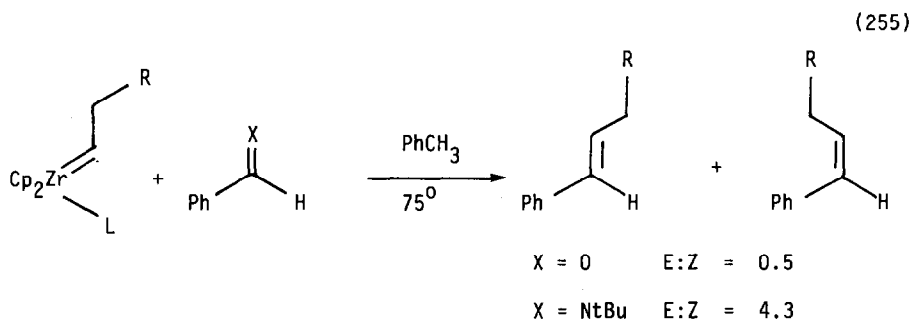
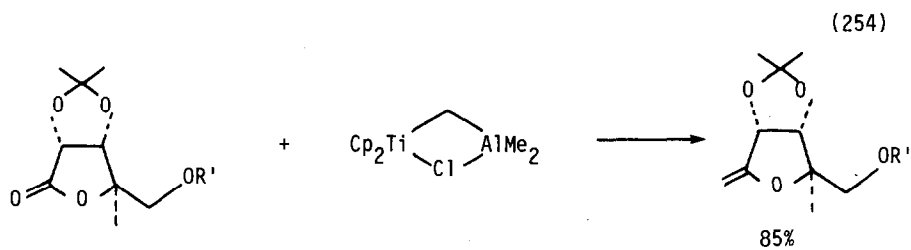

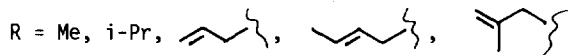
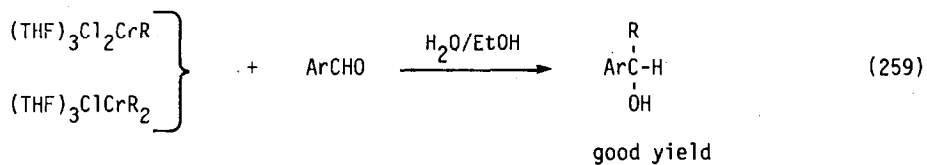

Acetals were alkylated by "RCu·BF<sub>3</sub>" reagents (equation 260), as were epoxides (equation 261) and orthoesters (equation 262) [278]. With chiral acetals, good asymmetric induction was observed (equation 263) [279]. The same reagent alkylated imines (equation 264) [280].

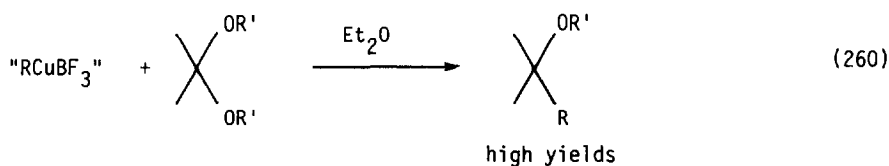

"RCuBF<sub>3</sub>" = C<sub>7</sub>CuLiX, PhCuLiX, MeCuLiX, Me<sub>2</sub>CuLi

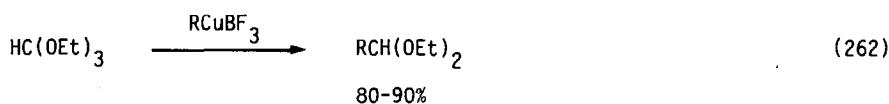
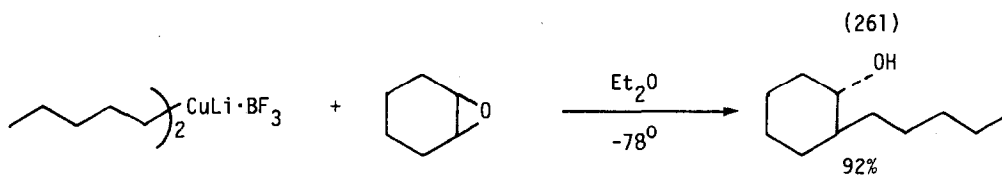
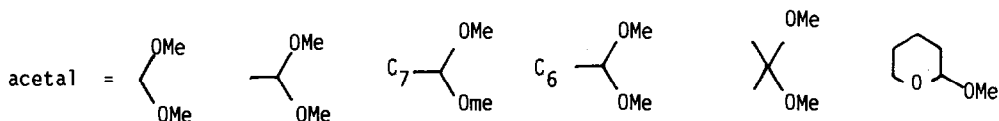
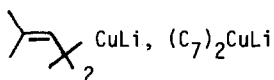

(263)

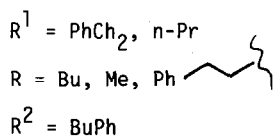
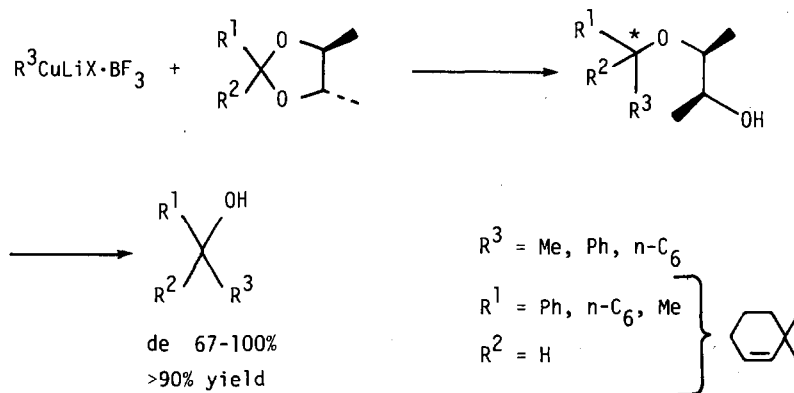

Samarium(II) iodide reductively alkylated ketones with chloromethyl phenyl ether (equation 265) [281].  $\omega$ -Iodoketones were cyclized by the same reagent (equation 266) [282]. Enol phosphates were alkylated by trialkylaluminum reagents in the presence of palladium(0) catalysts (equation 267) [283]. Enol triflates were alkylated by tin reagents under similar conditions (equation 268) (equation 269) [284].

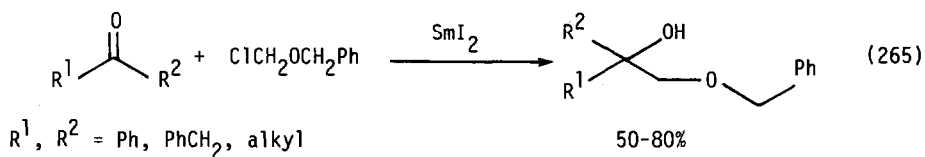

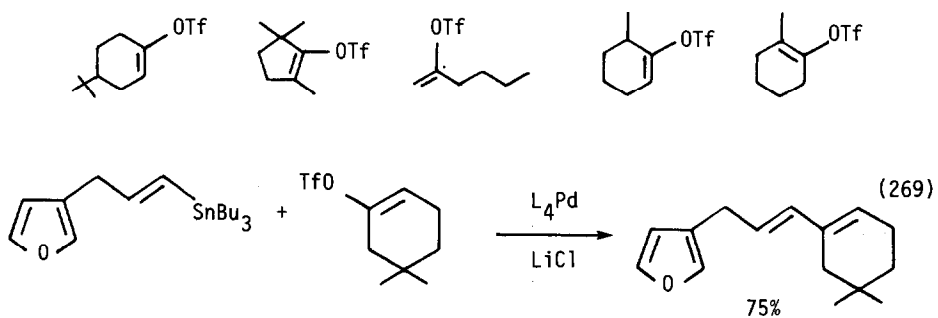
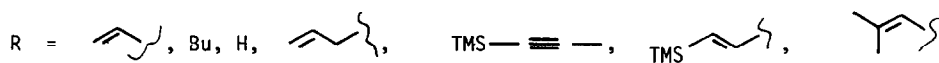
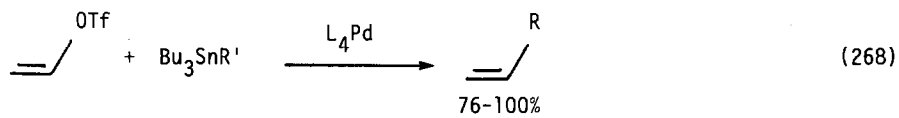
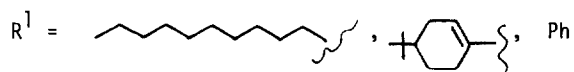
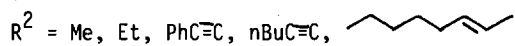
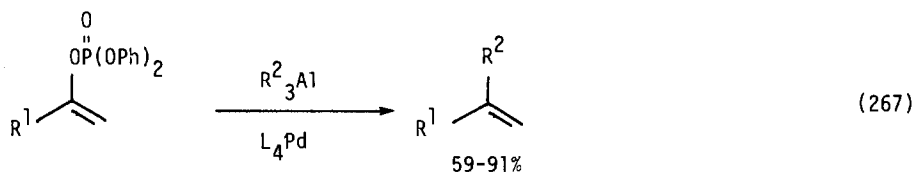
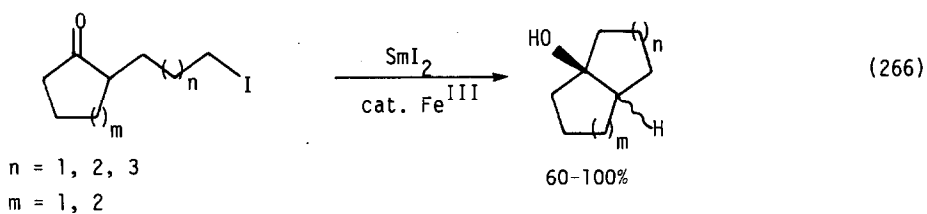

Aldehydes and ketones were alkylated by allylic halides when treated with fine particles of manganese metal [285]. Benzyl halides alkylated  $\alpha$ -diketones to pinacolones when treated with activated nickel powder (equation 270) [286]. Aldehydes were alkylated by perfluoroiodides when treated with zinc metal and nickel(II) or palladium(II) salts (equation 271) [287]. Ketone enolates alkylated  $\alpha$ -sulfonyl esters when treated with manganese(III) and copper(II) salts (equation 272) [288].

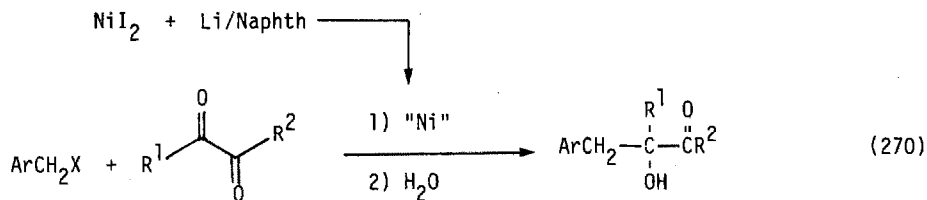

50-80%

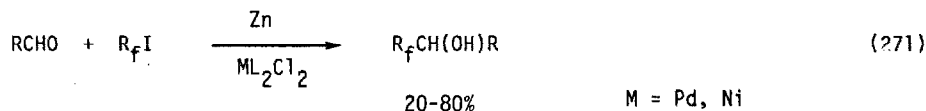
Ar = Ph, 4MePh, 3MePh, 3CF<sub>3</sub>Ph, 4FPh, 4ClPh, 4BrPh, 4CNPh, 4MeOPh, naphth.R<sup>1</sup>, R<sup>2</sup> = Ph, Me

20-80%

M = Pd, Ni

R = Ph, Ph-CH=CH-

M = Pd, Ni

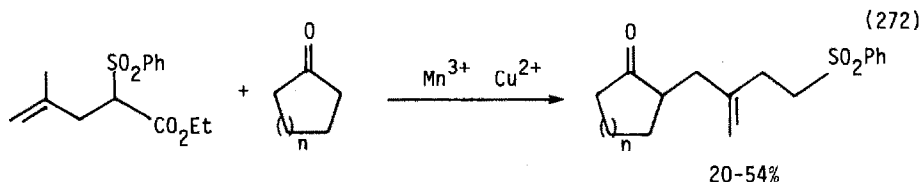
R<sub>f</sub> = CF<sub>3</sub>, C<sub>2</sub>F<sub>5</sub>, iC<sub>3</sub>F<sub>7</sub>, C<sub>4</sub>F<sub>9</sub>, C<sub>6</sub>F<sub>13</sub>, C<sub>8</sub>F<sub>17</sub>

20-54%

Six rules have been given in order to predict the conformations of pseudo-tetrahedral complexes, and the stereochemistry of their reactions [289]. Enolates of acyliron complexes underwent reaction with a variety of electrophiles (equation 273) [290]. Erythro  $\beta$ -hydroxy acids were prepared with high stereoselectivity taking advantage of the steric constraints imposed on these enolates by the iron and its associated ligands (equation 274) [291], (equation 275) [292], (equation 276) [293].



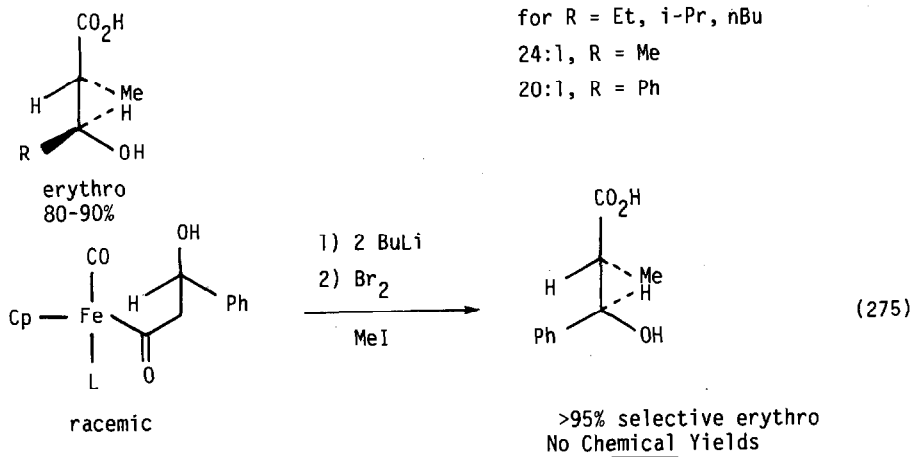
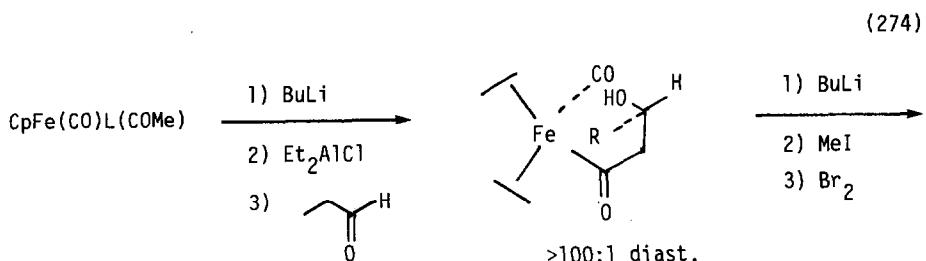
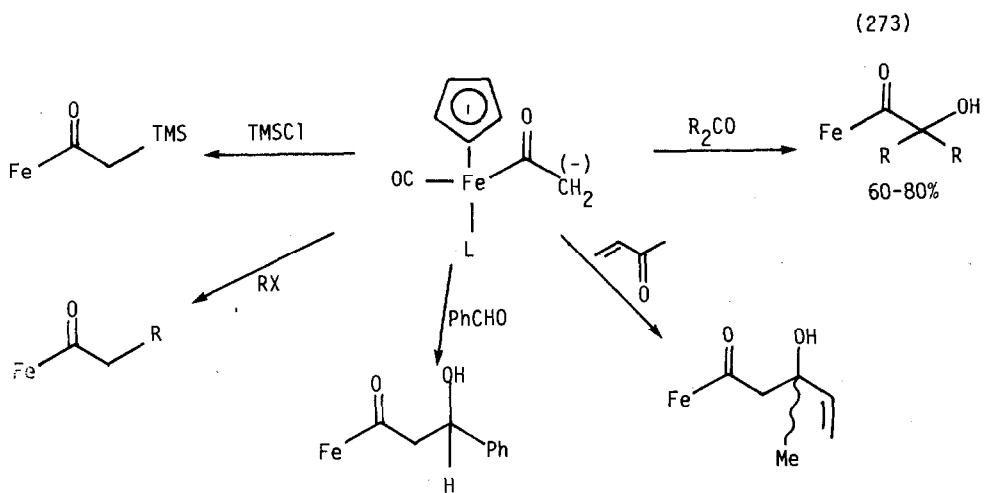

(relative configuration results from E-enolate - anti ( $\text{O}^-$  to  $\text{C}=\text{O}$ ) configuration from unshielded face)

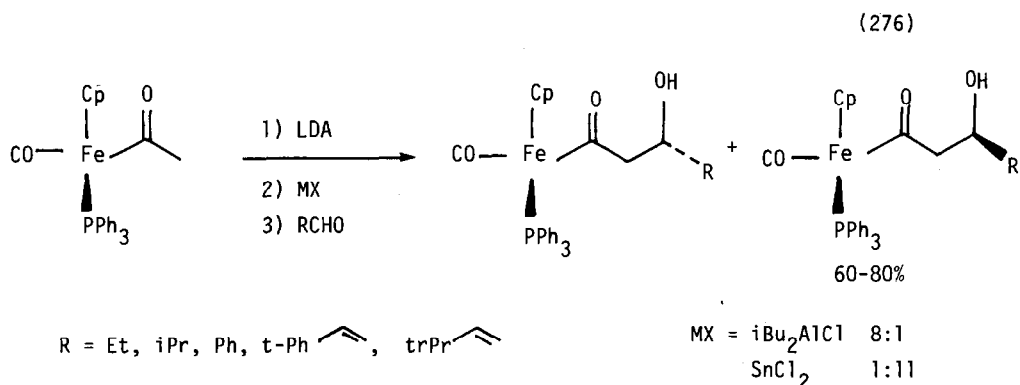

### 11. Alkylation of Aromatic Compounds

Arene and carbon-hydrogen bond activation in organotransition metal complexes was the topic of a dissertation [294]. The effect of substituents on the nucleophilic displacement of fluoride from substituted fluorobenzene chromium tricarbonyl complexes with methoxide nucleophile was shown to increase in the order  $p\text{-MeO} > o\text{-Me} > p\text{-Me} > m\text{-Me} > \text{H}$  [295]. A similar displacement of chloride from bis arene chromium complexes showed a rate dependence on the substituent in the nonreacting (transannular) ring [296].  $\eta^6$ -Pyridine chromium tricarbonyl complexes reacted with phenyllithium to give dihydropyridine complexes, from alkylation of the pyridine ring. In contrast, methyllithium caused reductive coupling of pyridine to dipyridyls [297]. The site of addition of the anion of 2-cyanopropane to the chromium tricarbonyl complex of N-methyl-1,2,3,4-tetrahydroquinoline depended on the solvent and the reaction time (equation 277) [298]. The mechanism of exchange of aryl groups in arenechromium tricarbonyl complexes was claimed to occur by stepwise decomplexation - eg. from  $\eta^6$  to  $\eta^4$  to  $\eta^2$  to  $\eta^0$  - while the incoming arene complexes from  $\eta^0$  to  $\eta^2$  to  $\eta^4$  to  $\eta^6$  (equation 278) [299]. Toluene, *p*-xylene and *m*-xylene underwent this arene exchange efficiently [300].

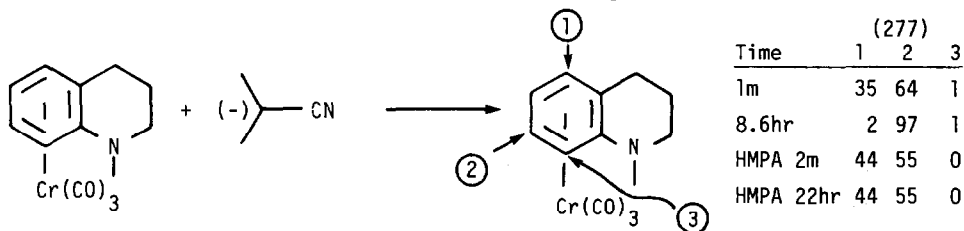



Activation of the benzylic position of aromatic compounds by complexation to chromium has been used extensively. Steroids were hydroxymethylated by benzylic deprotonation followed by condensation with formaldehyde. Alkylation occurred from the face opposite the metal (equation 281) [302][303]. Other complexed arenes underwent a similar reaction (equation 282) [302]. Activation by complexation to chromium was used in a number of ways in the synthesis of 11-deoxyanthracyclinone (equation 283) [304]. With polyalkylated aromatics, some selectivity among various benzylic positions was noted (equation 284) [305]. Chromium complexed toluene was acylated by treatment with base followed by diethyl oxalate (equation 285) [306], (equation 286) [307].

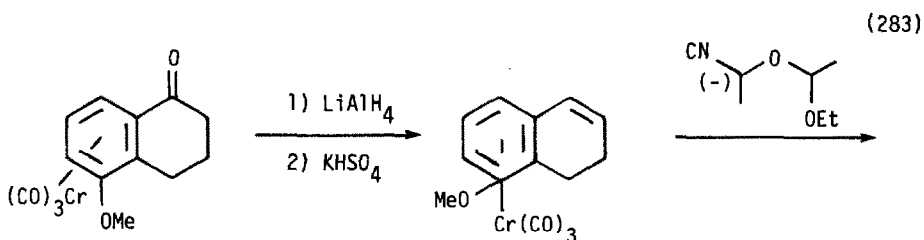
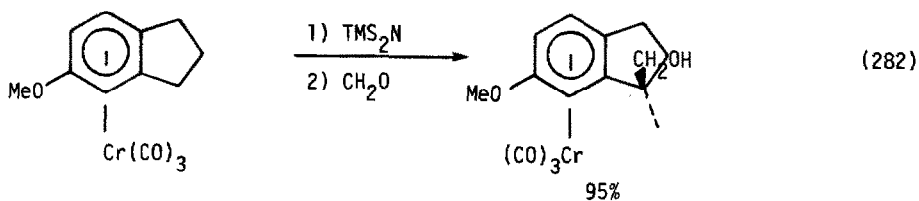
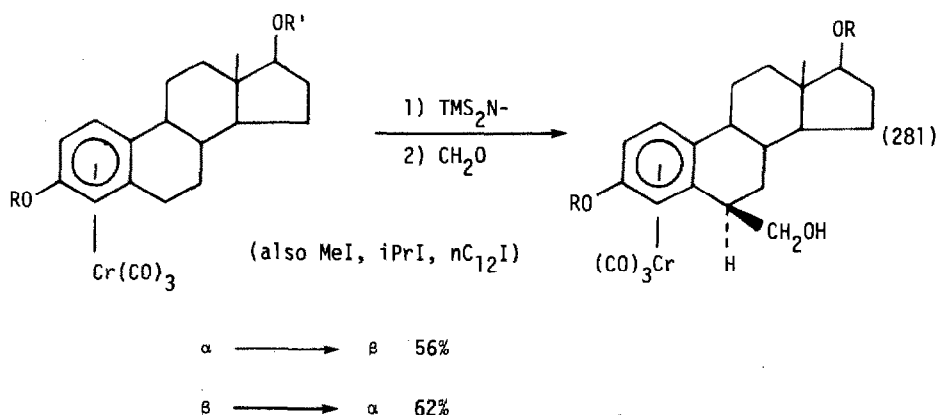

(continued on next page)

(283 continued)

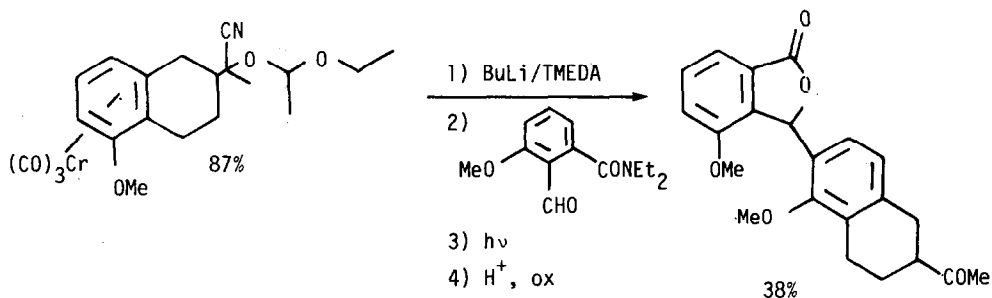

—————>—————> 11-Deoxyanthracyclinone

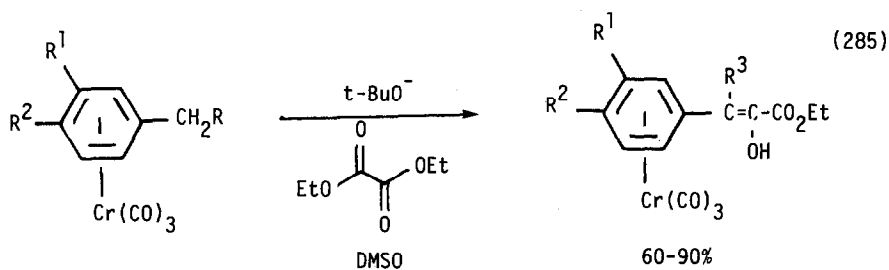
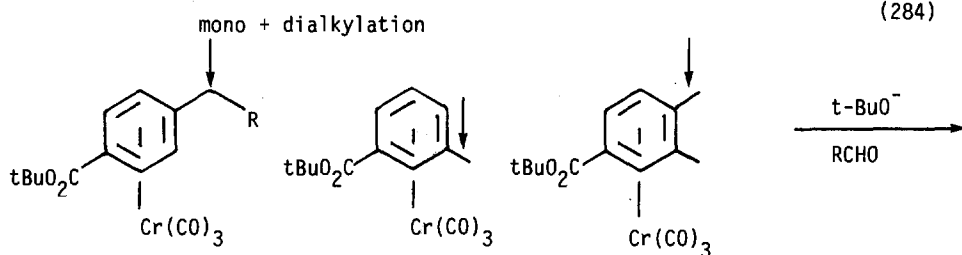

Applications of organoiron complexes of aromatic compounds in organic synthesis has been reviewed (230 references) [308]. Bis arene iron dications underwent sequential attack by hydride, than alkyllithium to give cyclohexadiene complexes (equation 286) [309]. Arenes were reduced to cyclohexadienes via manganese-hydrogen-carbon bond bridged cyclohexenylmanganese tricarbonyl complexes (equation 287) [310]. Phenol or thiophenol complexes of iron underwent ring expansion when treated with diazomethane (equation 288) [311].

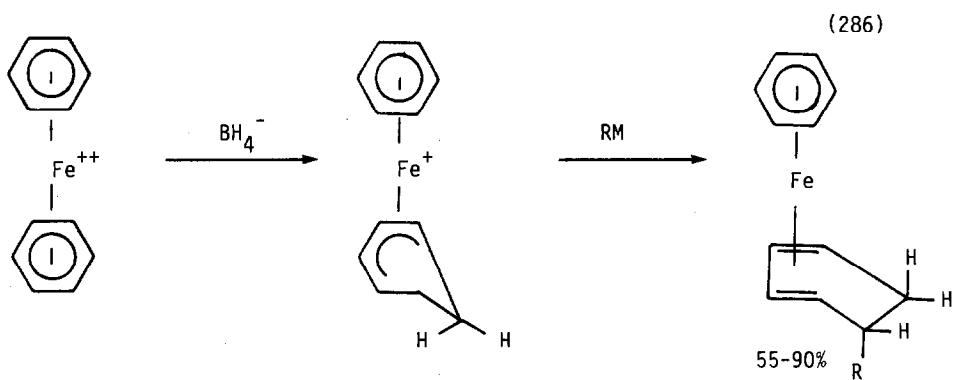

RM = BH<sub>4</sub><sup>-</sup>, KCN, NaCH(CO<sub>2</sub>Et)<sub>2</sub>, PhMgBr

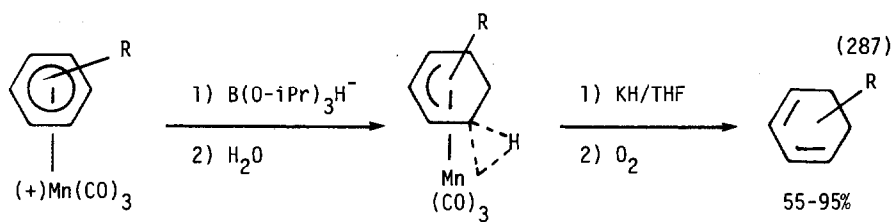
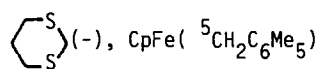

R = Me, Ph, OMe, 1,2-diMe

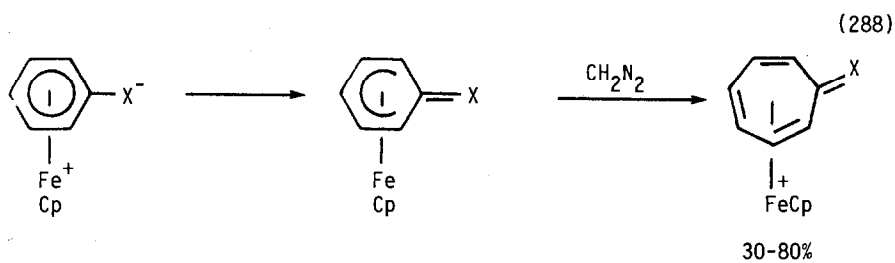

X = O, S

## 12. Alkylation of Dienyl and Diene Complexes

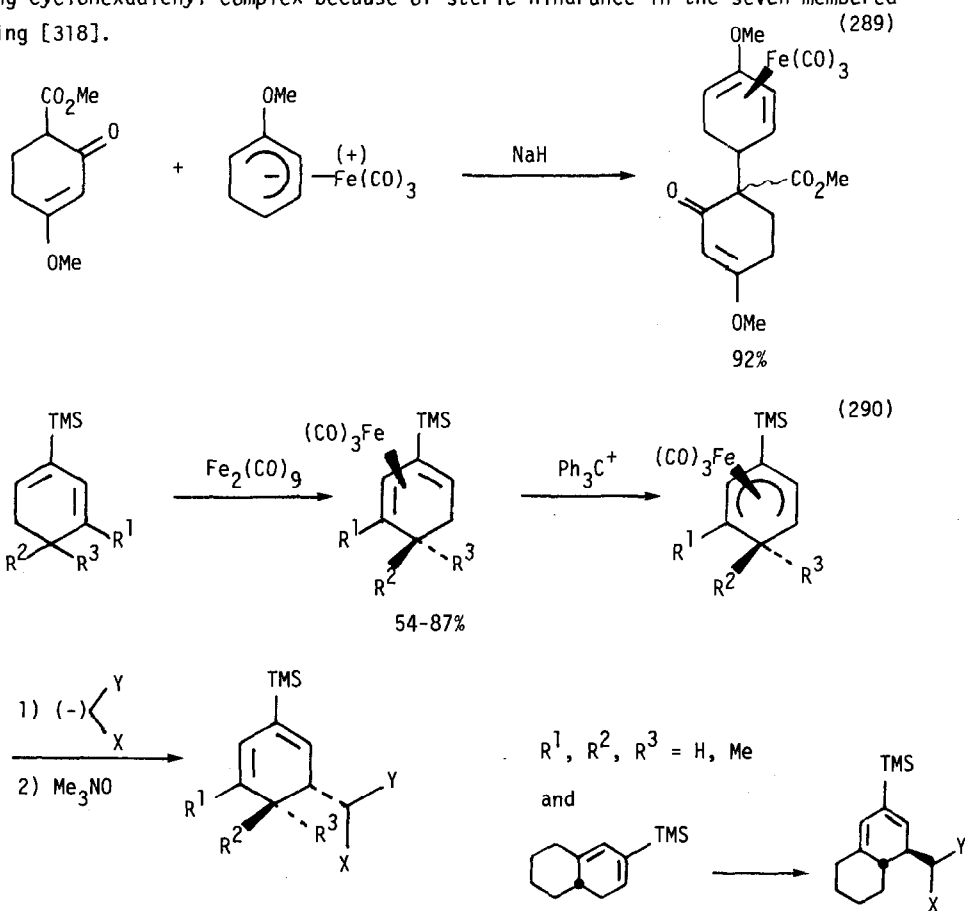

The synthesis and characterization and reactions of pentadienyl transition metal compounds was the topic of a dissertation [312]. Iron stabilized carbocations as intermediates for organic synthesis was the topic of a review (50 references) [313], as was natural products synthesis using organoiron complexes [314]. Dienyliron complex chemistry has been used to synthesize (+)-0-methyl-joubertiamine (equation 289) [315]. The regiochemistry of nucleophilic attack on cationic substituted cyclohexadienyl iron complexes has been examined (equation 290) [316]. Racemic methoxycyclohexadienyl complexes of iron have been resolved by treatment with (R)(+)- $\alpha$ -phenethylamine, and the absolute configuration deduced from circular dichroism measurements (equation 291) [317]. The cationic cycloheptadienyl complex of iron was 16 to 200 times less reactive than the corresponding cyclohexadienyl complex because of steric hindrance in the seven membered ring [318].

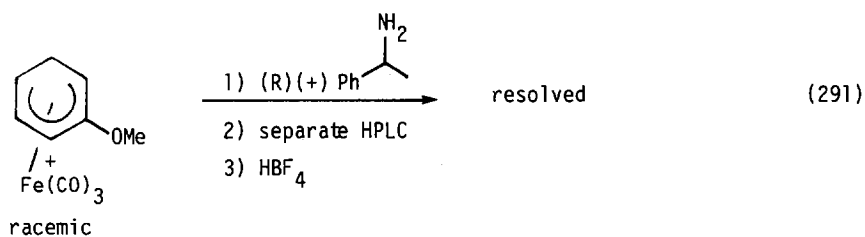

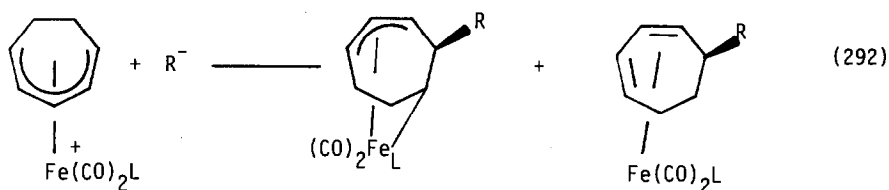

Cycloheptadienyl complexes of iron reacted with nucleophiles to give either substituted diene complexes or  $n^1$ -alkyl- $n^3$ -allyl complexes, depending on the nucleophile and the ligands on iron (equations 292 and 293) [319]. Manganese complexes of cycloheptatriene underwent alkylation by a wide range of carbanions (equation 294) [320].  $n^1$ -Allyliron complexes annellated cyclopentyl rings onto an appropriate dienyliron complex (equation 295) [321].



L = Ph <sub>3</sub> P, (Ph) <sub>3</sub> P	CN	100	0	91%
	SPh	0	100	94%
	p-MeOPhS	0	100	91%
	MeLi	100	0	69%
	Me <sub>2</sub> CuLi	0	100	100%
	BuLi	9	1	92%
	Bu <sub>2</sub> CuLi	1	3	75%
	PhLi	100	0	91%
	Ph <sub>2</sub> CuLi	0	100	77%
	 MgX	10	1	72%
	 CuLi	1	5	79%
		0	100	100%

X = CO<sub>2</sub>R; Y = CO<sub>2</sub>R, CN, SO<sub>2</sub>Ph



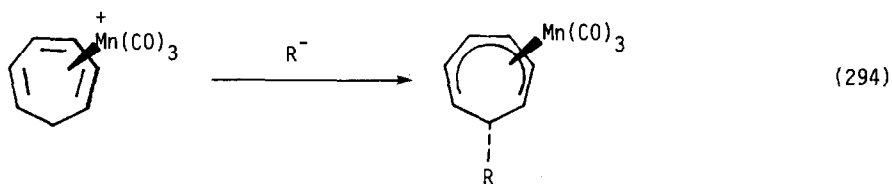
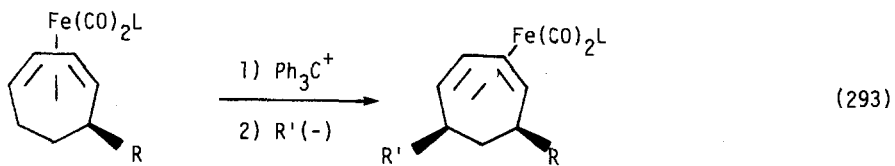

$R^- = \text{CH}(\text{CO}_2\text{Me})_2, \text{CMe}(\text{CO}_2\text{Me})_2, \text{CH}(\text{COMe})(\text{CO}_2\text{Me}), \text{CH}(\text{SO}_2\text{Ph})(\text{CO}_2\text{Me}),$

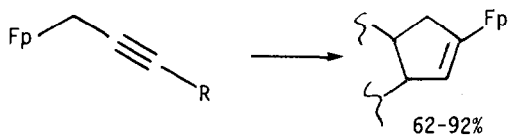
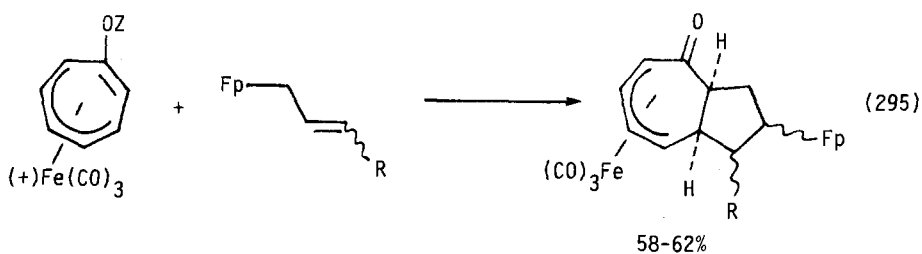
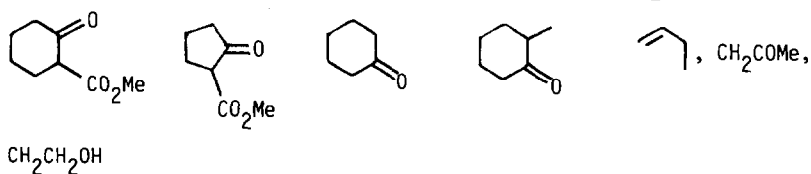



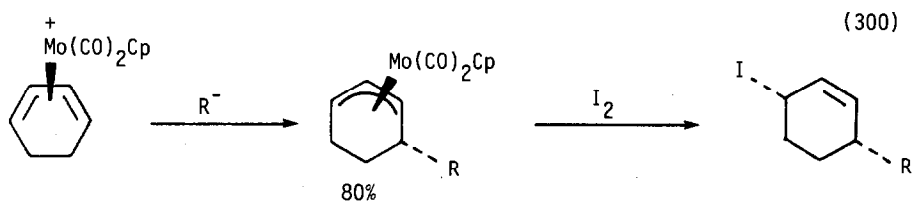
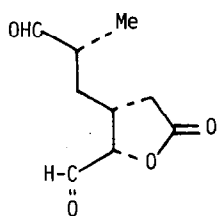
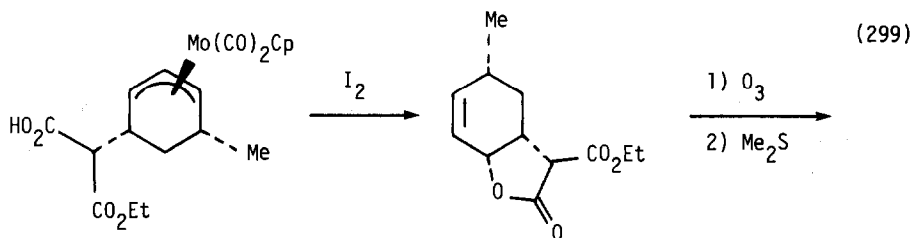
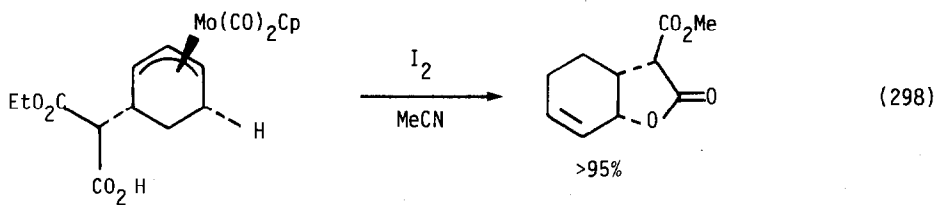

$\text{R} = \text{CH}(\text{SO}_2\text{Ph})(\text{CO}_2\text{Me})$

$\text{CH}(\text{COMe})(\text{CO}_2\text{Me})$ ,

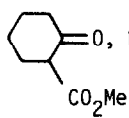

$\text{MeC}(\text{CO}_2\text{Me})_2$ ,

$\text{pMeOPh}$ ,

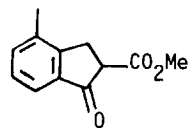

(continued on next page)

(equation 300 continued)

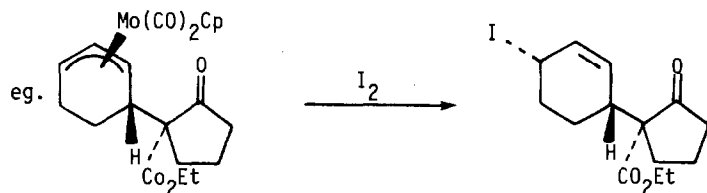

Dienals were complexed to iron to permit reactions of the aldehyde group to go cleanly and with high stereospecificity (equation 301) [326] (equation 302) [327]. Iron complexes of chiral enones were prepared. Upon exchange of the enone ligand for a diene ligand, up to 40% chirality transfer was observed (equation 303) [328]. The reactions of dienes with Grignard reagents in the presence of iron or nickel salts has been examined [329].

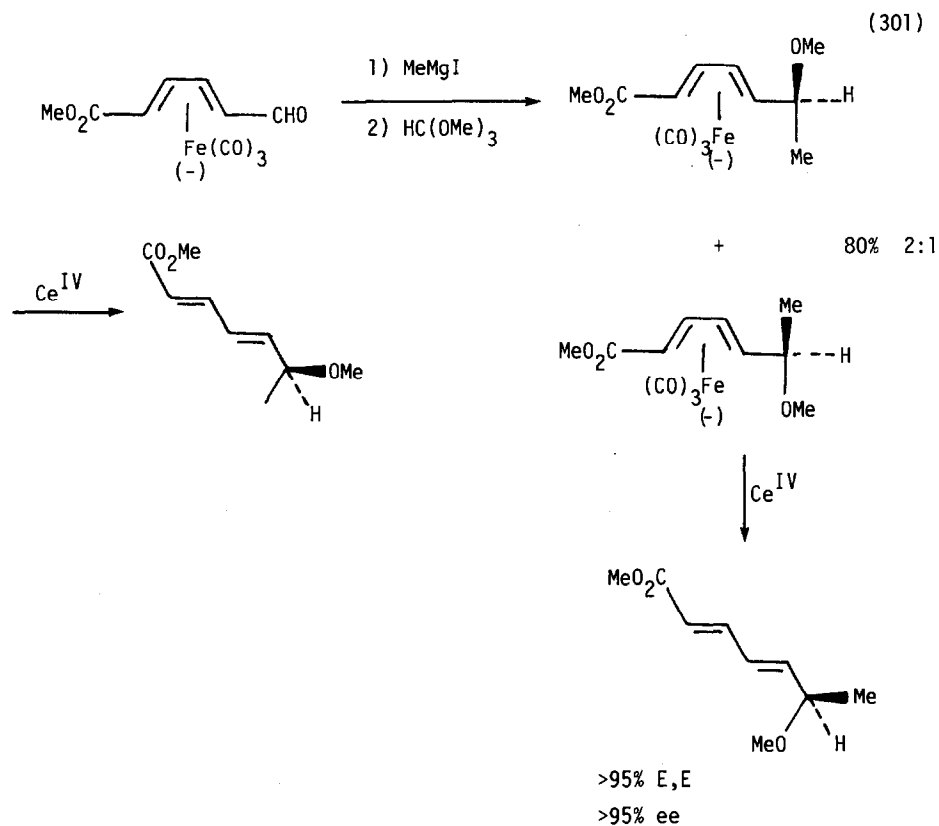

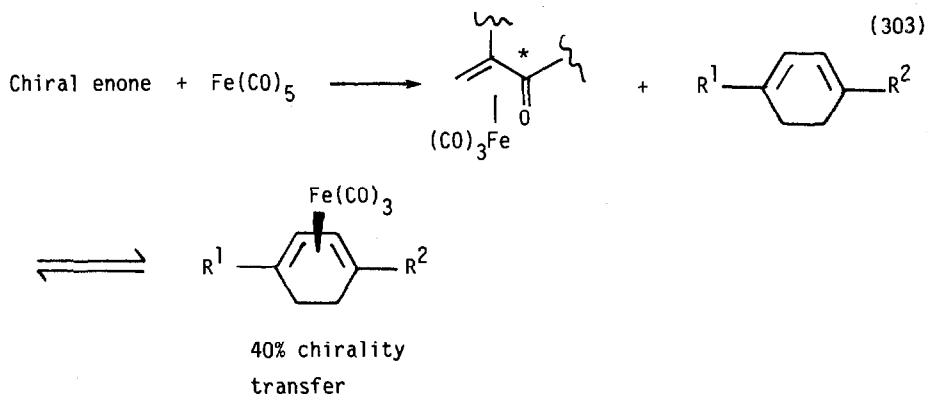
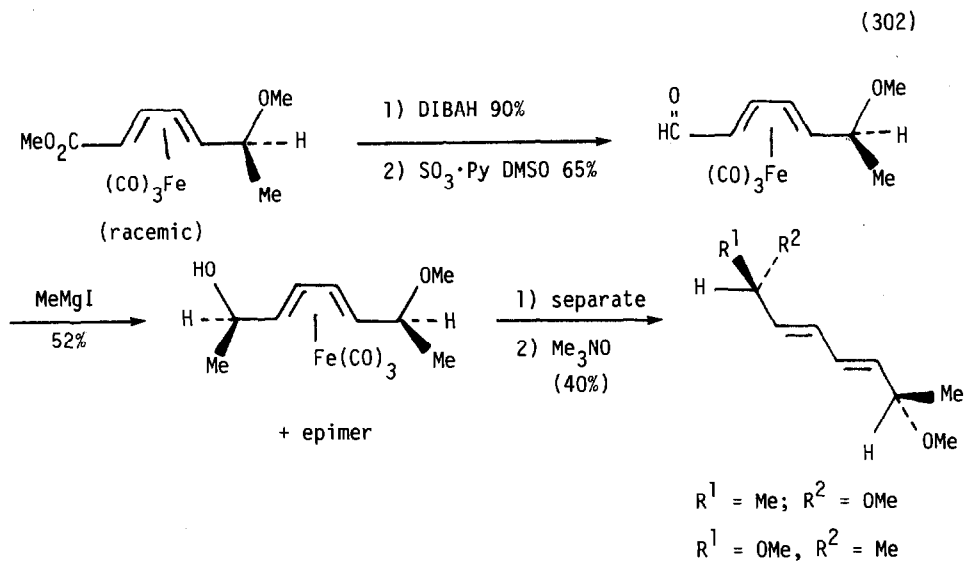

### 13. Metal-Carbene Reactions

The synthesis of metal-carbene complexes has been reviewed (476 references) [330], as has carbene complexes in organic synthesis (181 references) [331], (54 references) [332], and carbon-carbon bond formation via carbonyl carbene complexes (58 references) [333]. A review (149 references) on vinylidene and propadienylidene metal complexes has appeared [334]. Electrophilic tungsten alkyl alkylidenes is the subject of a dissertation [335]. Theoretical calculations on  $(\text{CO})_5\text{Cr}^+\equiv\text{CH}$  and  $\text{H}_2\text{MeNb}=\text{CH}_2$  have been carried out [336]. Treatment of Group(VI) carbonyls with LDA followed by Meerwein's reagent gave mono and bis carbenes (equation 304) [337].

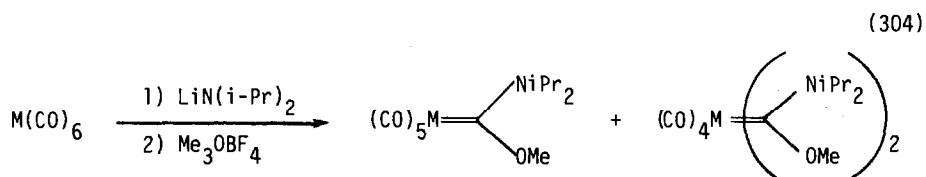

Alkynes combined with methoxy-vinyl carbene complexes of chromium to produce hydroquinone mono ethers in good yield (equations 305 and 306) [338]. This process was used to synthesize tetracyclins (equation 307) [339]. With gem disubstituted vinyl carbenes, cyclohexadienones were obtained (equations 308 and 309) [340]. A stereospecific synthesis of alkenylcarbene chromium complexes has been developed [341]. A dissertation entitled "Palladium(II) and chromium carbene mediated synthesis of organic compounds" has appeared [342]. Photolysis of mixtures of chromium carbene complexes with imines produced  $\beta$ -lactams in high yield and in a stereo- and regiospecific manner (equation 310) [343]. The same reaction using azobenzenes as substrates produced 1,3-diazetidines in a process thought to involve an "azo metathesis" (equation 311) [344].

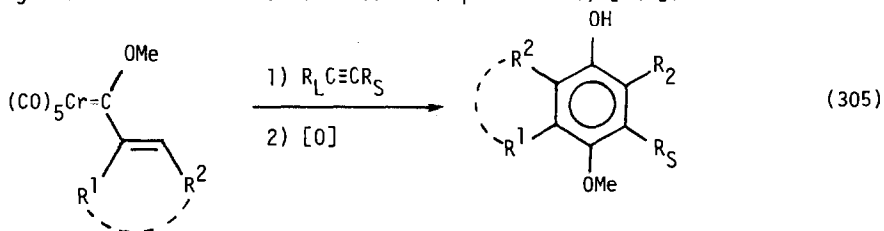

$\text{R}^1, \text{R}^2 = (\text{CH}_2)_3, (\text{CH}_2)_4, (\text{CH}_2)_5, \text{O}(\text{CH}_2)_3\text{O}, \text{O}(\text{CH}_2)_2\text{O}, \text{EtO-Me}, \text{EtO-H}, \text{Me-H}, \text{H-Me}$   
 $\text{R}_2 = \text{Ph}, \text{Et}, \text{n-Pr}, \text{R}_L, \text{Me}_2\text{CCHCH}_2, \text{EtOCH}_2, \text{PhCO}, \text{MeO}_2\text{C}, \text{ZMeOCH=CH}, (\text{EtO}_2\text{C})_2\text{NHAc}$   
 $\text{R}_S = \text{H}, \text{Ph}, \text{Et}, \text{MeO}_2\text{C}$

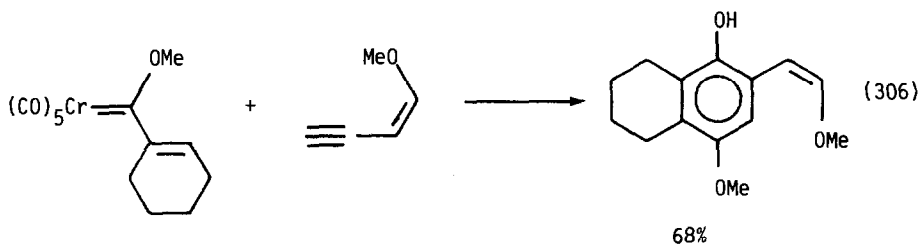

(307)

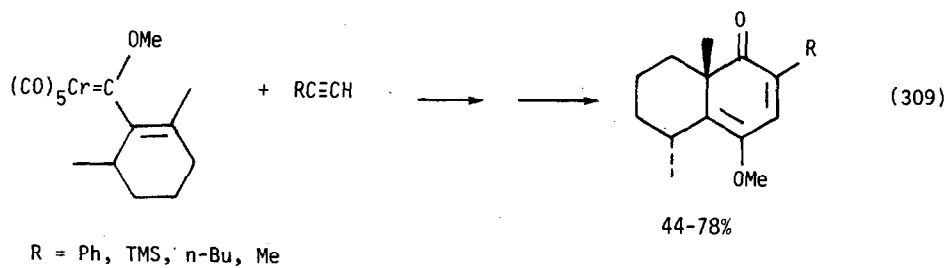
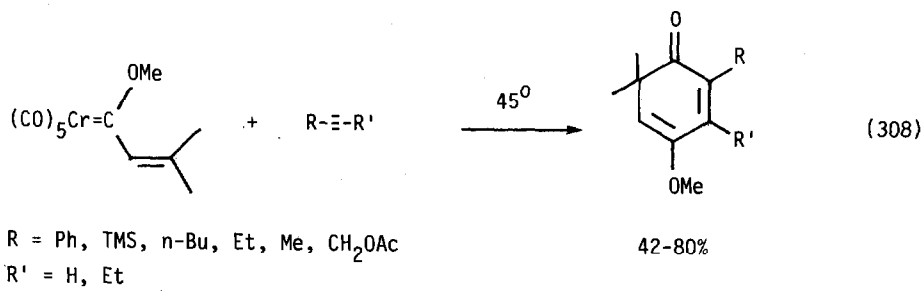
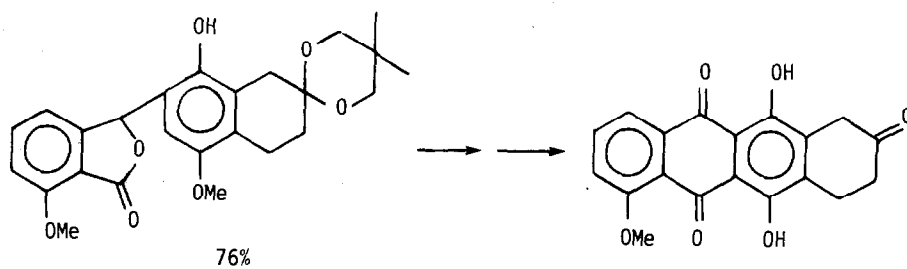
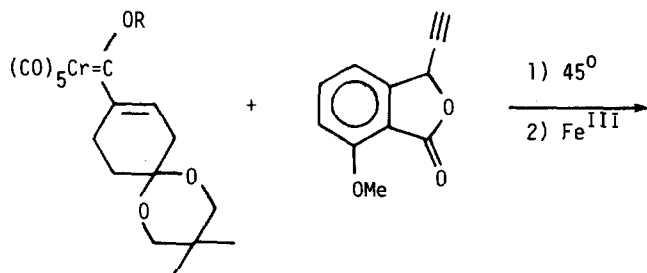

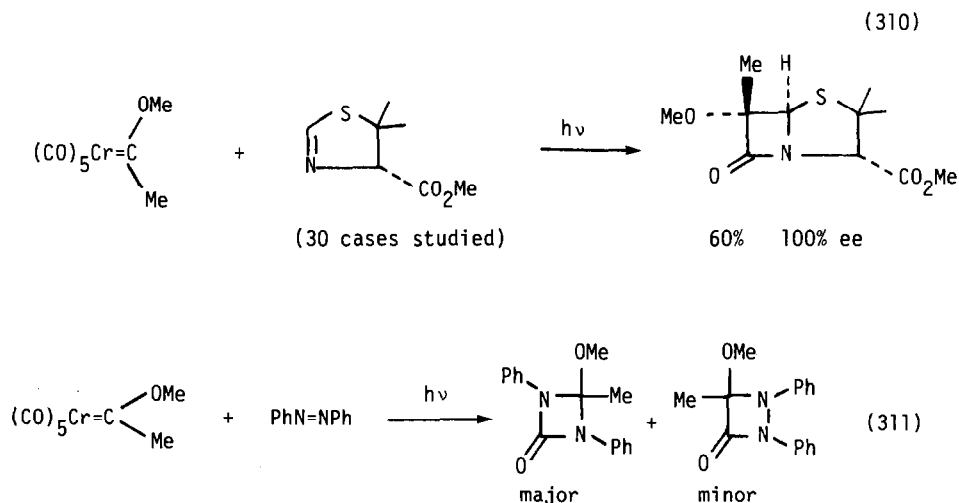

The role of olefin-carbene complexes in cyclopropanation of olefins was demonstrated by isolation and x-ray structure determination of one such complex (equation 312) [345]. Tungsten carbene complexes converted alkynes to conjugated enones via metallacyclization -  $\beta$ -hydride elimination (equation 313) [346]. Insertion of a carbene into a  $\omega$ -phenyl bond has been demonstrated (equation 314) [347]. Isonitriles combined with chromium carbene complexes to produce dimeric glyoxime ligands (equation 315) [348].

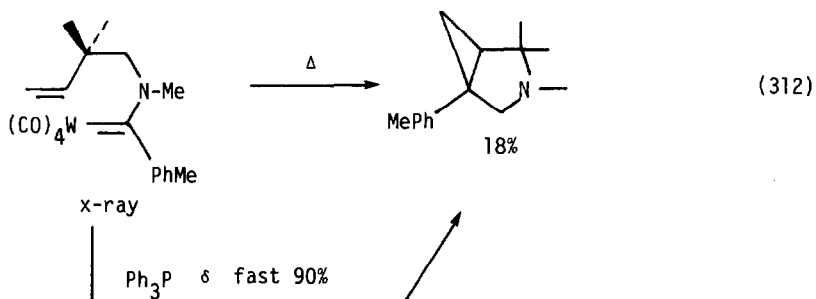



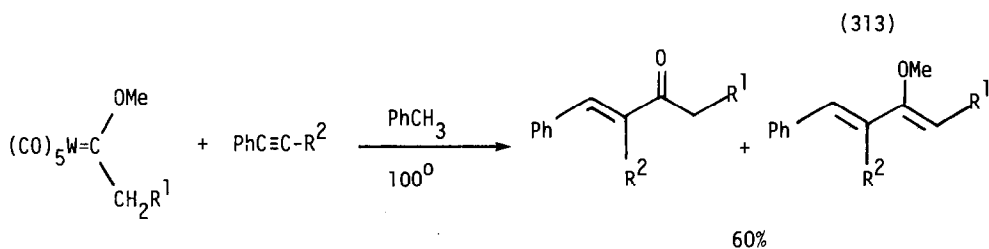

$\text{R}^1 = \text{H}, \text{Me}; \text{R}^2 = \text{Ph}, \text{Me}$

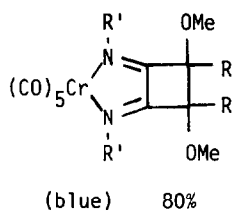
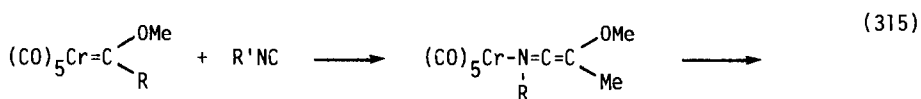
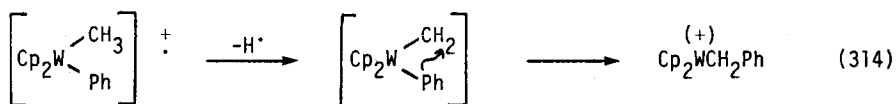
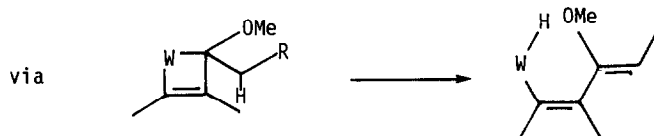

The stereochemistry of addition of nucleophiles to iron carbene complexes is that resulting from addition from "the top of the enolate" (equation 316) [349], (equation 317) [350], (equation 318) [351].

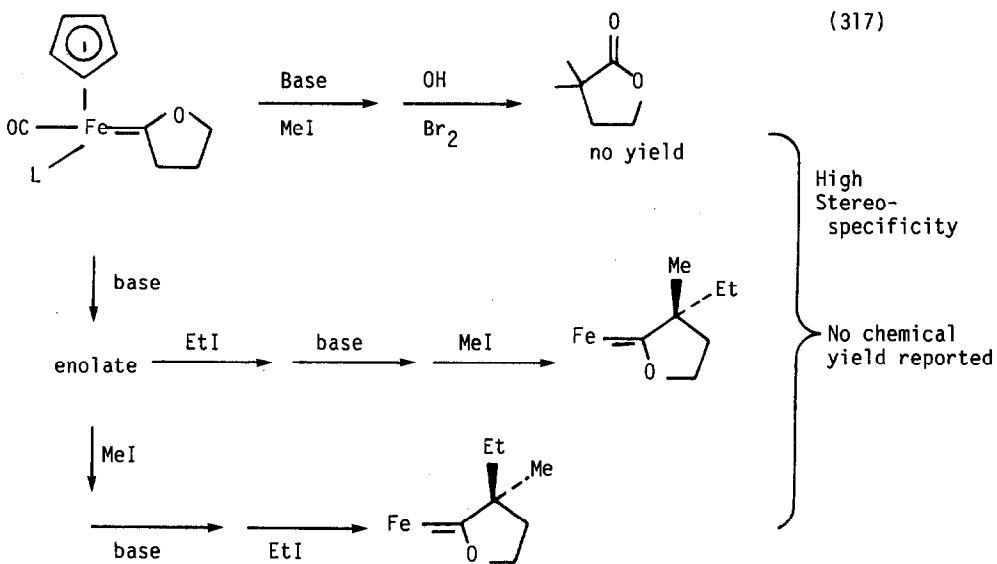
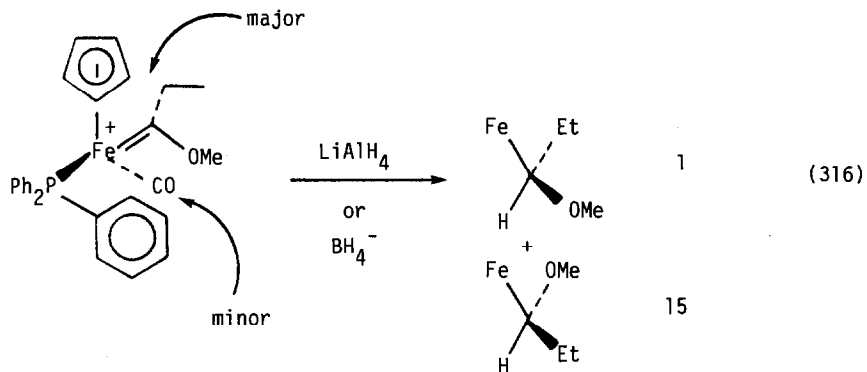

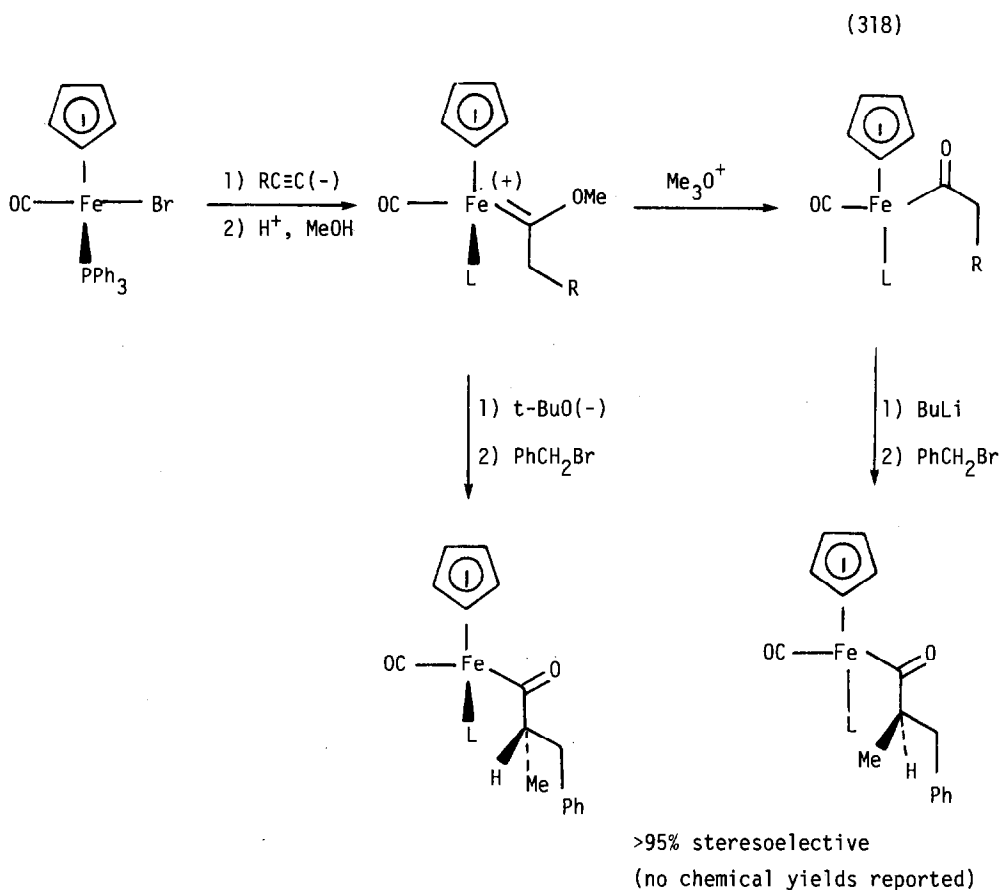

### B. Conjugate Addition

Organocuprates continue to be the reagents of choice for conjugate additions to enones, and several new, more efficient reagents have been developed. The higher order cuprate  $[\text{R}_2\text{CuCN}]\text{Li}_2$  was very efficient in the  $\beta$ -alkylation of conjugated enones, even those containing  $\beta$ -disubstitution (equation 319) [352]. The rate of this reaction was further enhanced by the presence of  $\text{BF}_3 \cdot \text{OEt}_2$  in the reaction medium [353]. The mixed cuprate  $\text{RCu}(\text{PCy}_2)\text{Li}$  was also efficient in the  $\beta$ -alkylation of conjugated enones, as well as in other typical organocuprate reactions (equation 320) [354]. Organocuprates  $\beta$ -alkylated  $\gamma$ -pyrones bearing  $\alpha$ -carbonyl groups (equation 321) [355]. From  $^{13}\text{C}$  measurements, it was claimed that the first step of conjugate addition reactions was complexation of the enone to copper [356]. Steroidal allyl epoxides were ring opened by organocuprate reagents (equation 322) [357]. Prostaglandin synthesis by three-component coupling (equation 323) was the topic of a review [358]. Copper(I) salts catalyzed the 1,4-addition of zinc homoenolates of esters to conjugated enones (equation

324) [359]. Copper-imine complexes also added in a 1,4-fashion to conjugated enones (equations 325 and 326) [360]. Alkyl and aryl silylcuprates introduced this useful functional group into a number of conjugated enones (equations 327 and 328) [361].



R = n-Bu, sec-Bu, , t-Bu, Ph

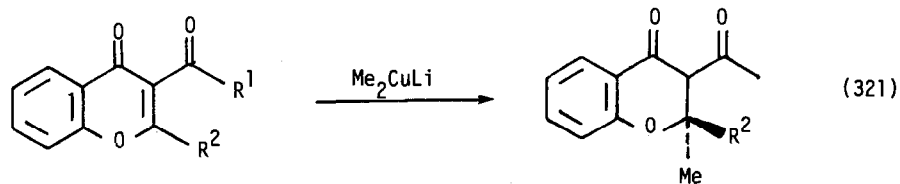
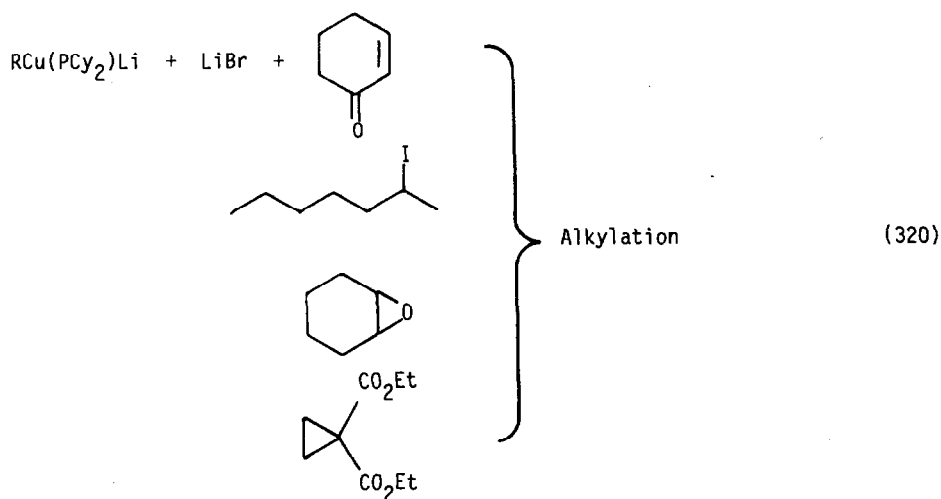
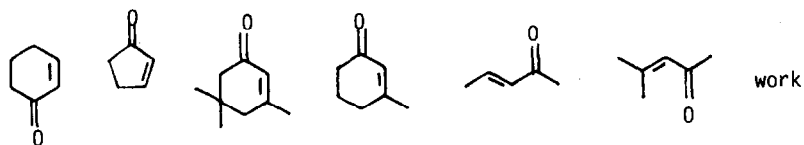

R<sup>1</sup> = Ph, OMe, Me, H

R<sup>2</sup> = H, Me

50-78% yield

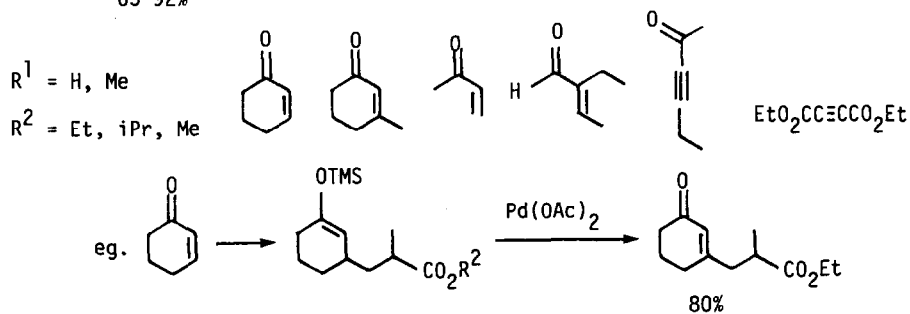
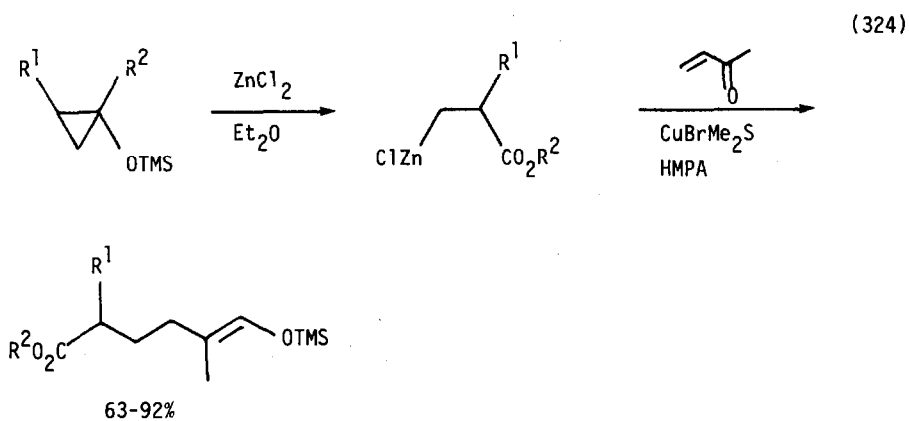
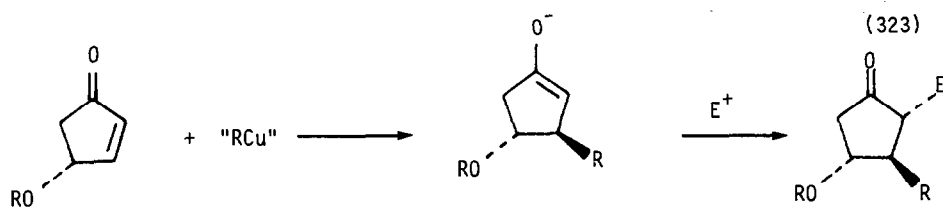
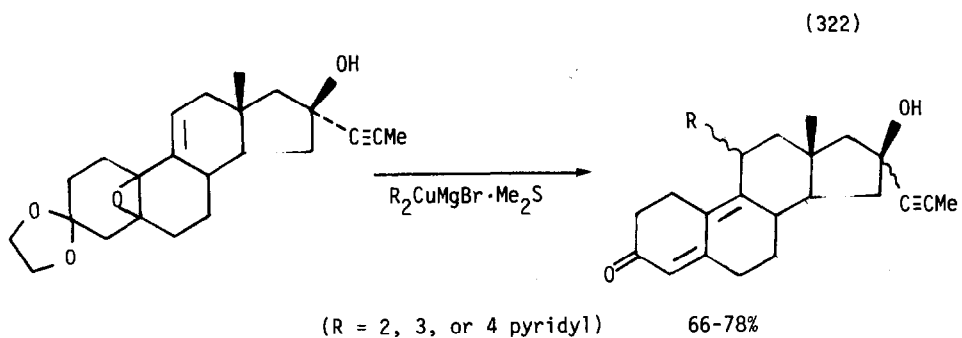

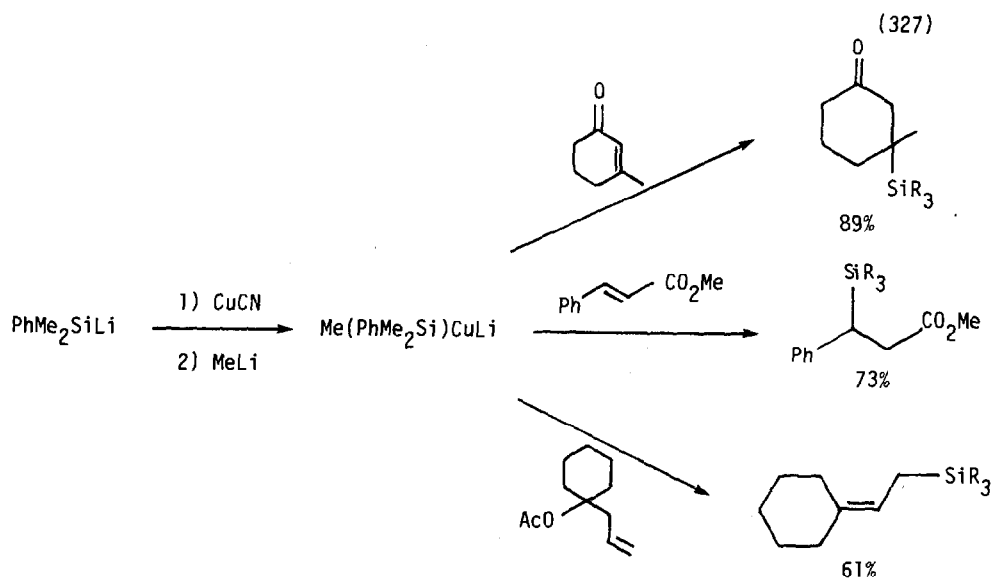
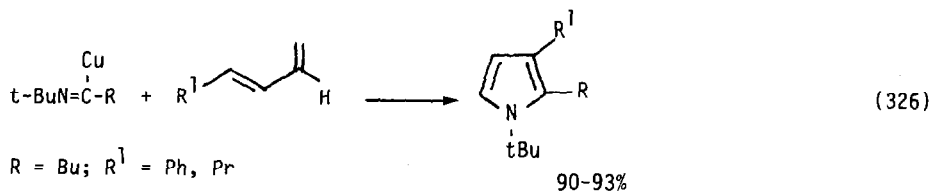
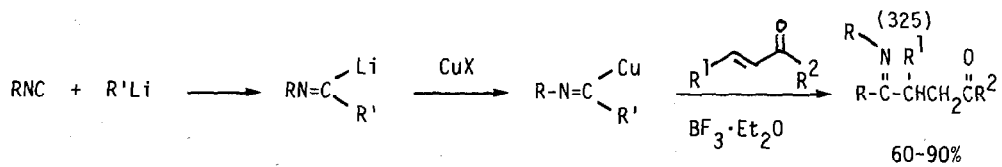

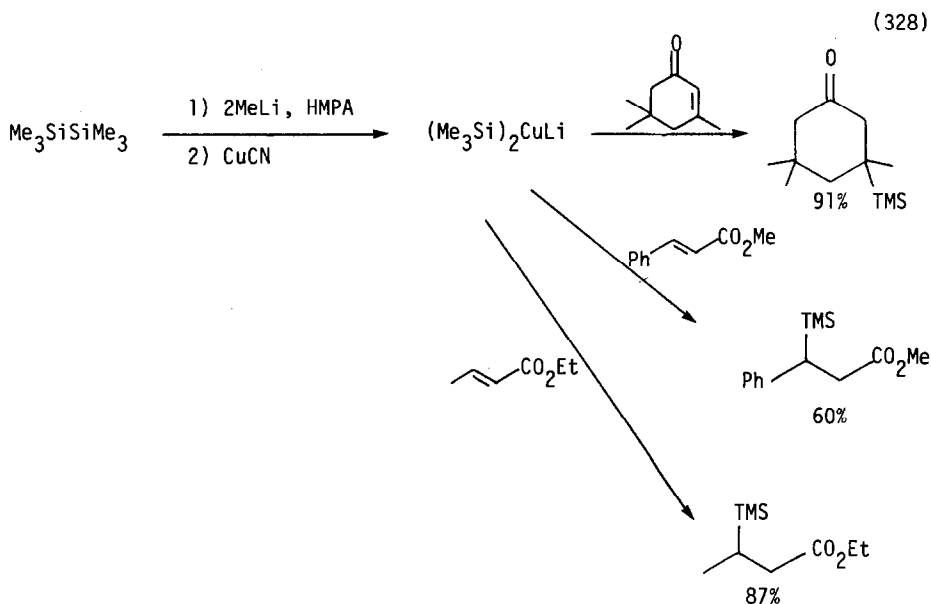

A number of systems involving 1,4-additions to chiral substrates have been developed. Chiral aldehydes were produced by the addition of organocuprates to chiral enamines of conjugated aldehydes (equation 329) [362]. Addition of vinyl cuprates from chiral allylic alcohols added to conjugated enones with high asymmetric induction (equation 330) [363]. With chiral  $\beta$ -binapenones, organocuprates added with complete retention (equation 331) [364]. Direct insertion of the metal into the C-X bond was claimed. Addition of organocuprates to chiral  $\alpha$ -sulfoxide- $\alpha,\beta$ -unsaturated ketones proceeded with high ee (equations 332 and 333) [365]. Vinyl cuprates added 1,4- to  $\gamma$ -carboethoxy- $\alpha,\beta$ -unsaturated ketones to give a mixture of isomers (equation 334) [366].  $\alpha$ -Cuprates of chiral imines added to cyclopentenones with high ee (equation 335) [367]. Chiral cobalt catalysts promoted high ee in the addition of  $\beta$ -ketoesters to conjugated enones (equation 336) [368].

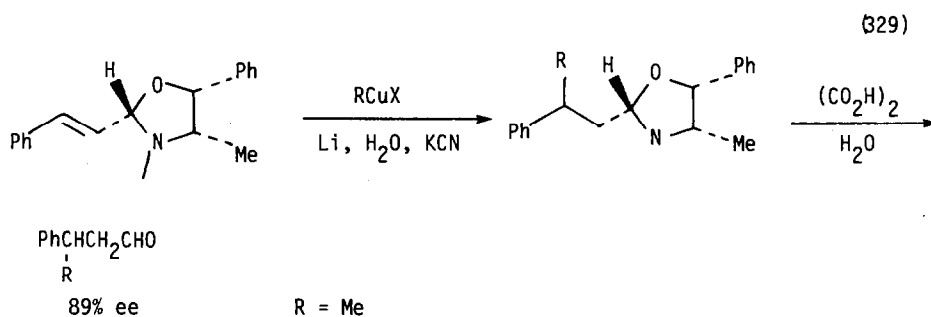

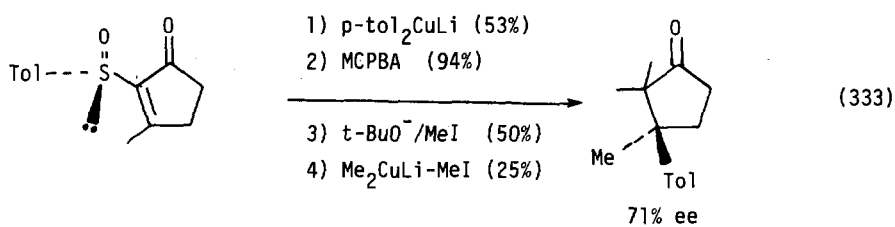
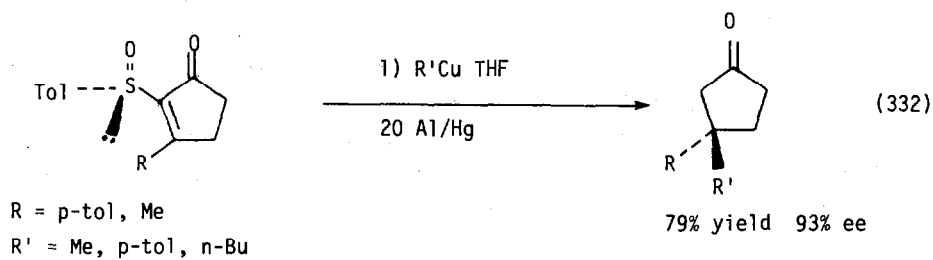
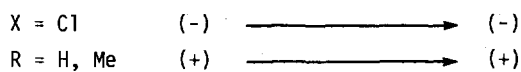
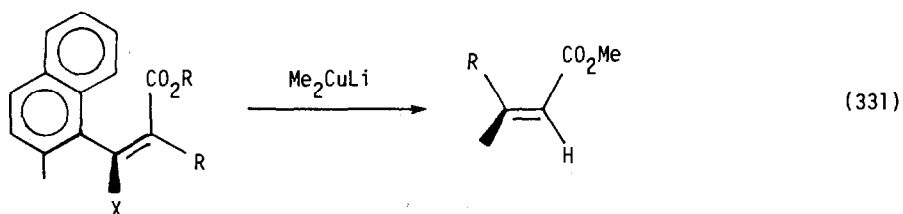
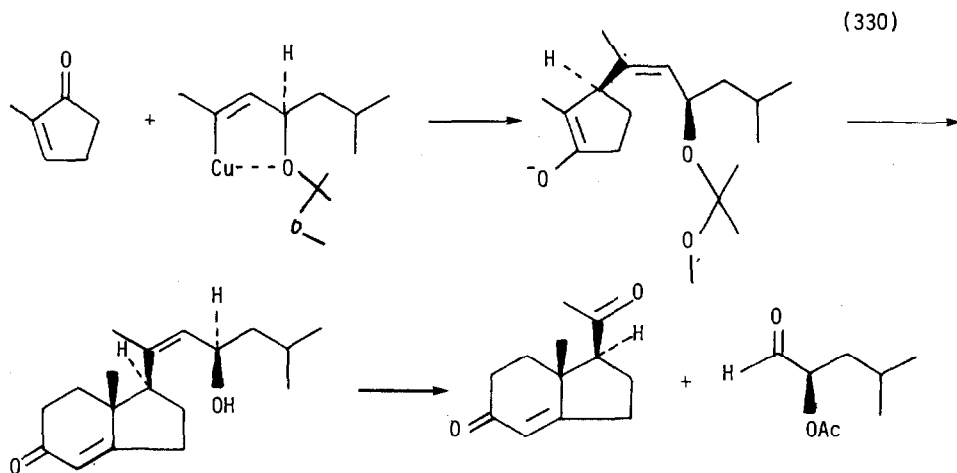



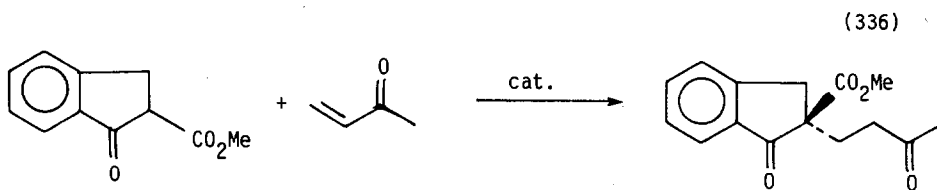
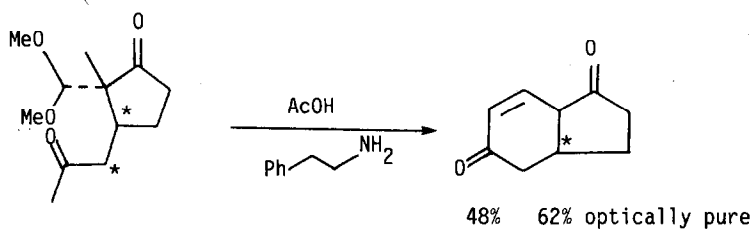
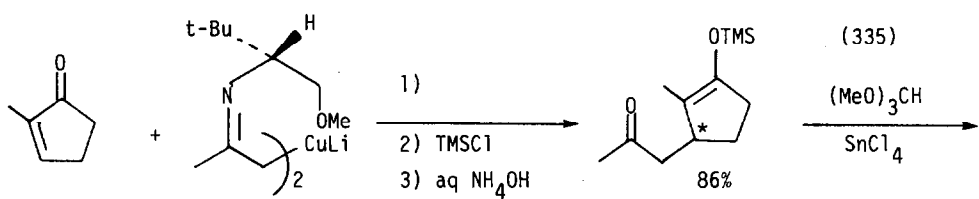
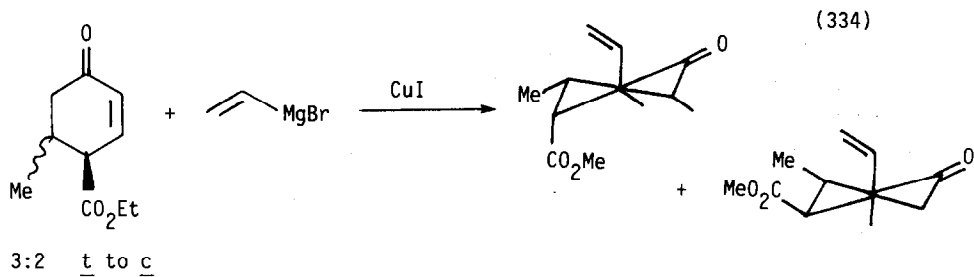

cat. = Co(acac)<sub>2</sub>/(+)-1,2-diphenyl-1,2-ethane diamine

66% ee, 50% yield   
 28% ee, 83% yield

$\beta$ -Selenylsulfonates were  $\beta$ -alkylated by organocuprates (equation 337) [369].  $\beta$ -Phosphonates of  $\alpha,\beta$ -unsaturated esters were  $\beta$ -alkylated by organocuprates (equation 338) [370]. Vinyl cuprates alkylated vinylphosphorous compounds (equation 339) [371]. Addition of organocuprates to cyclopropyl ketones was studied.  $\alpha$ -Stabilization of the enolate was necessary and the reaction went via an  $S_N2'$  process (equation 340) [372]. Copper(II) and nickel(II) chelates catalyzed the Michael addition of acetyl acetone to  $\beta$ -nitro styrene [373].

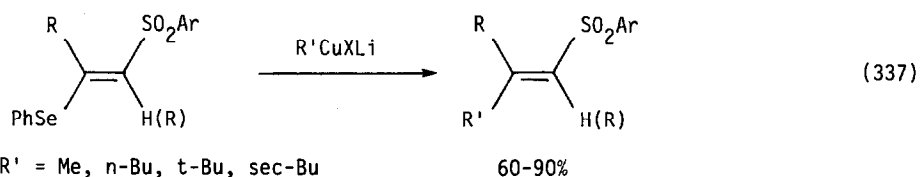

R' = Me, n-Bu, t-Bu, sec-Bu

R = H, n-C<sub>8</sub>, n-Bu, TMS, Ph

(338)

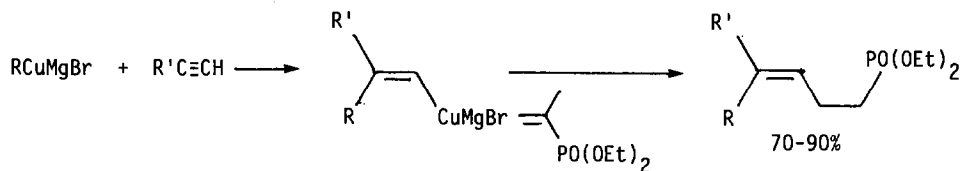
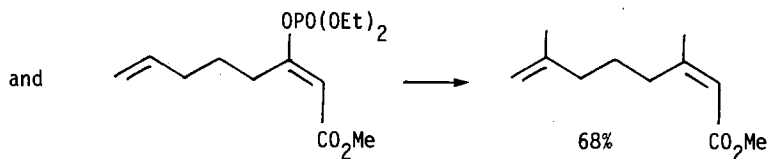
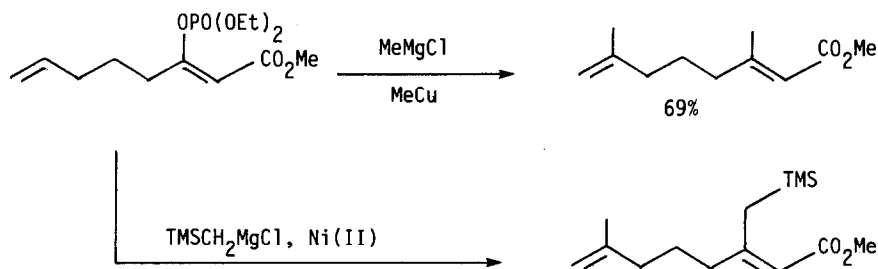

R = Et, n-Bu; R' = H, Me, 

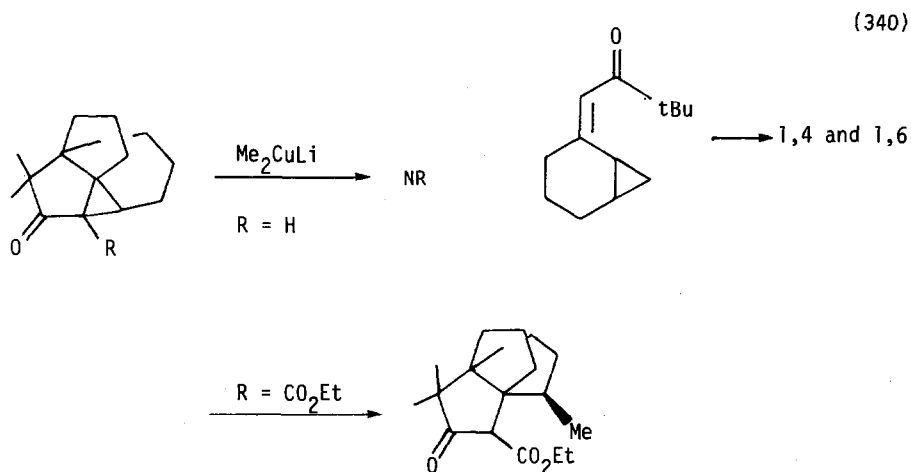

N-Acylated pyridinium salts underwent alkylation at the 4-position by Grignard reagents in the presence of copper salts (equation 341) [374]. Titanium(IV) chloride promoted the Michael addition of allyl silanes to  $\alpha,\beta$ -unsaturated acid cyanides (equation 342) [375]. Benzyltitanium(IV) species added 1,4 to conjugated enones (equation 343) [276]. Alkylmanganese(II) ate complexes  $\beta$ -alkylated  $\alpha,\beta$ -unsaturated ketones (equation 344) [377]. Acyl cobalt species were produced from the reaction of ketenes with hydridocobalt tetracarbonyl (equation 345) [378]. Iron-complexed fluorene Michael added to conjugated enones to give the alkylated hydrocarbon (equation 346) [379].  $\alpha,\beta$ -Unsaturated carbonyl compounds were reduced to unsaturated alcohols by iridium(I)-diamine complexes [380] and to saturated ketones by  $\text{Pd}/\text{HCOOH}/\text{Et}_3\text{N}$  systems [381].

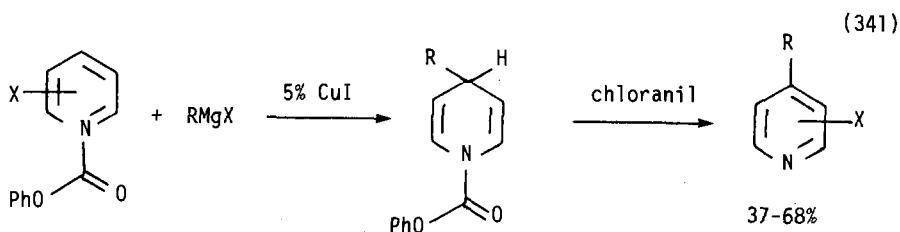

$\text{R} = \text{Me}, \text{Et}, \text{n-Bu}, \text{i-Pr}, \text{cyclohex}, \text{t-Bu}, \text{Ph}$   
 $\text{X} = \text{Br}, \text{Cl}$

(341 continued)

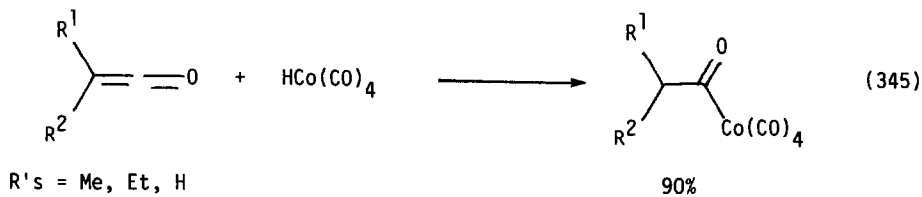
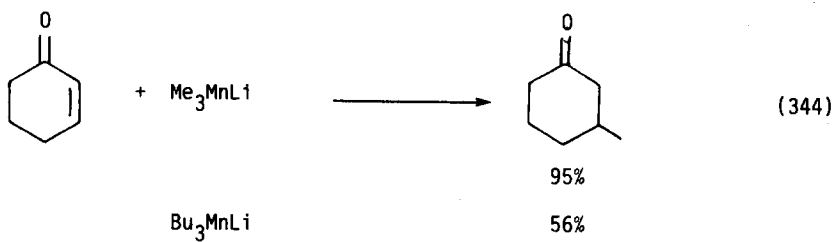
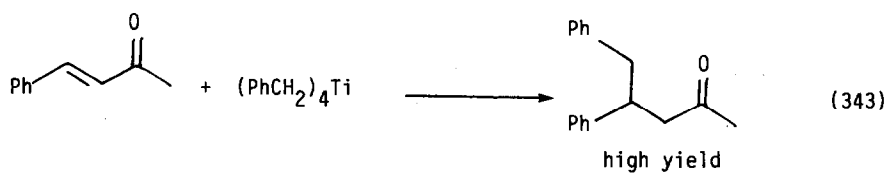
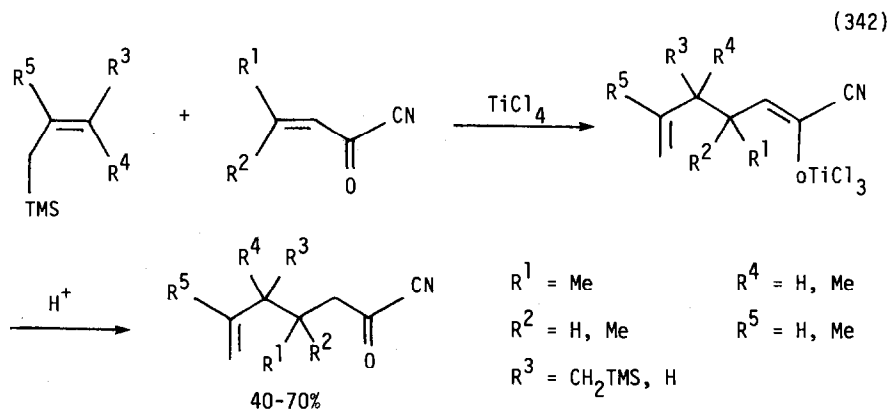
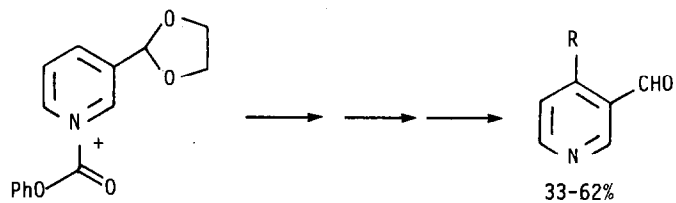

(346)

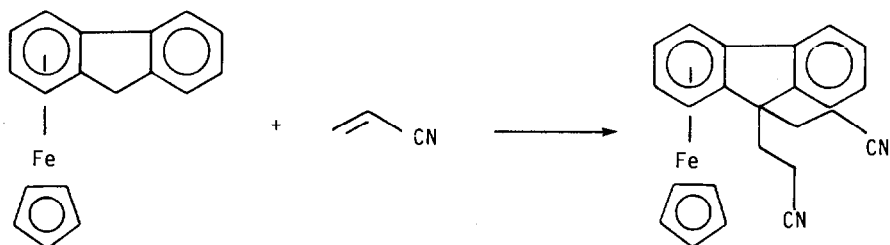

### C. Acylation Reactions

A review dealing with hydroformylation reduction and oxidation (494 references) has appeared [382]. Allylic halides were converted to  $\beta,\gamma$ -unsaturated aldehydes by treatment with carbon monoxide and hydrogen in the presence of palladium(II) complex catalyst (equation 347) [383]. 1-Nonene was hydrocarboxylated to linear  $C_{10}$  esters by catalyst such as  $(Ph_3P)_2PdCl_2/SnCl_2/Me_3CO/ROH$  in the presence of 24 atoms of carbon monoxide [384]. With chiral diphosphines as ligands, up to 52% ee was obtained in the palladium(II) catalyzed hydrocarboxylation of 2-phenylpropene [385]. Olefins were converted to monoesters of diols by reaction with carbon monoxide in the presence of a palladium(II) catalyst (equation 348) [386]. Alkynes were converted to cyclopentenones by hydrocarboxylation followed by reaction with alkyl cuprates (equation 349) [387]. Lactones were produced from aromatic alkynes by combined acetoxy mercuration/palladium catalyzed carbonylation (equation 350) [388]. Prostacyclin analogs were synthesized by alkoypalladation/carbonylation of norbornadiene palladium(II) complexes (equation 351) [389]. Palladium(II) complexes catalyzed the intramolecular alkoypalladation/carbonylation of olefins to give lactones (equation 352) [390], (equation 353) [391].

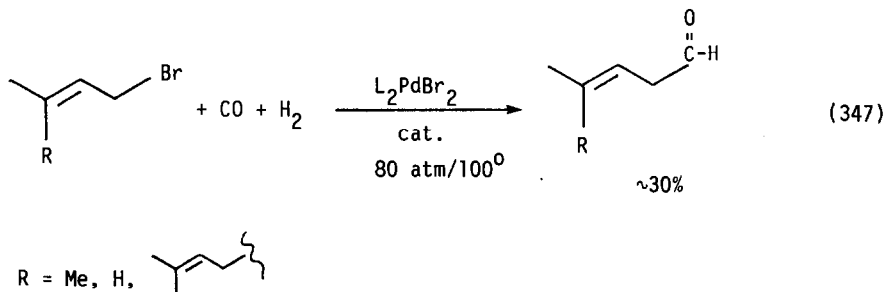

(348)

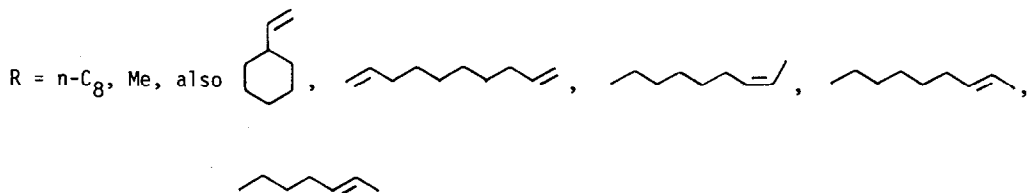
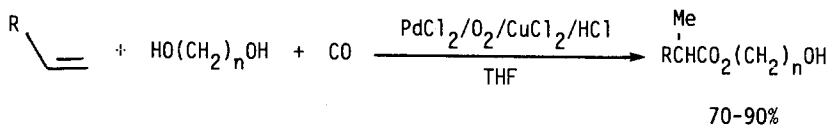

(349)

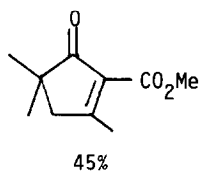
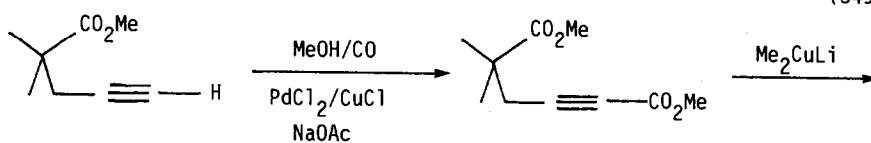

(350)

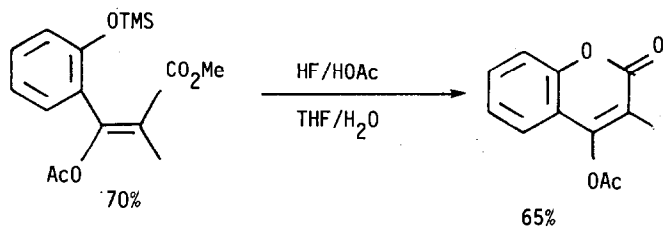
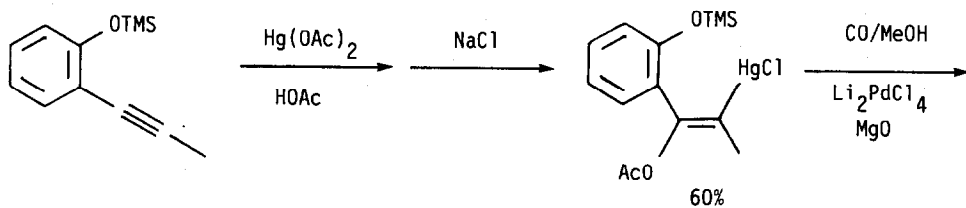

(351)

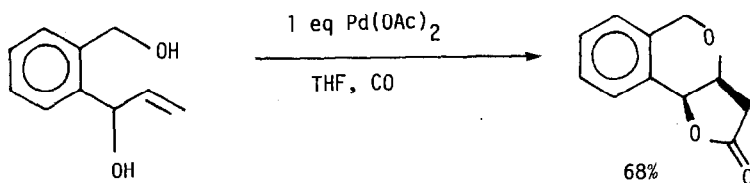
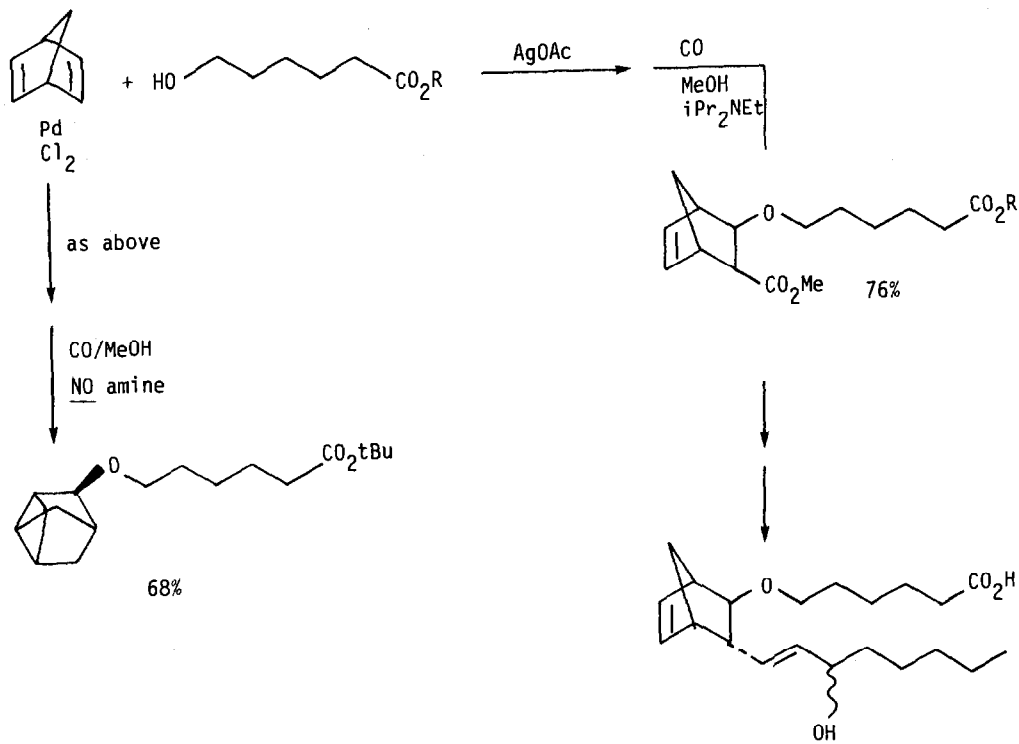

Free OH favors cis lactone regardless of stereochemistry at C<sub>1</sub>.

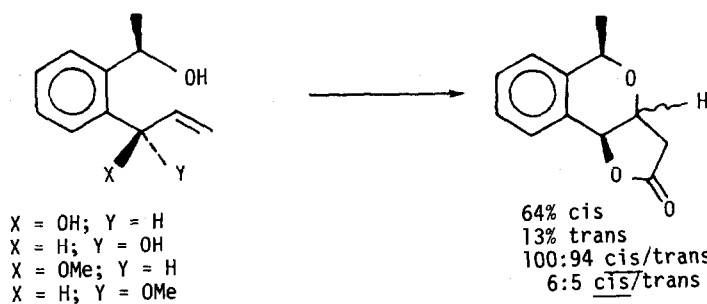

(352)

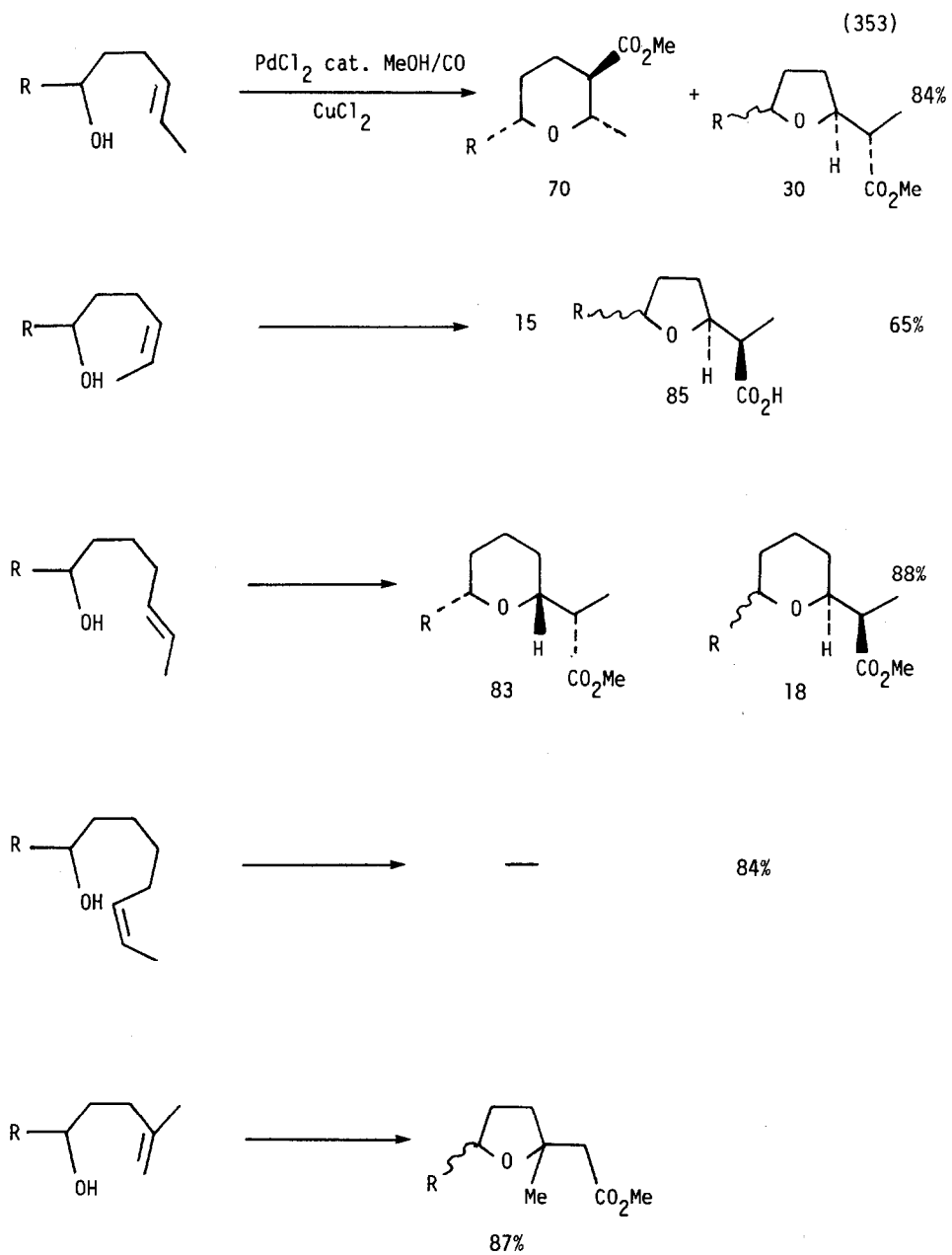



Conjugated dienes were carboxylated by reaction with acylcobalt carbonyl complexes followed by nitronate anions (equation 354) [392]. Allene underwent amination/acylation upon reaction with carbon monoxide and nickel(II) amine complexes (equation 355) (equation 356) [393]. Allenes were methoxy carbonylated using palladium(II) catalysts (equation 357) [394].

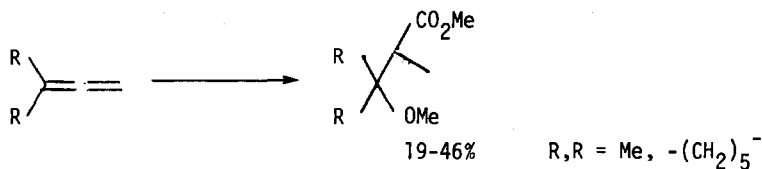
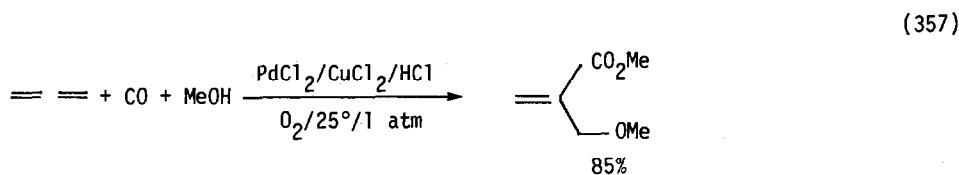
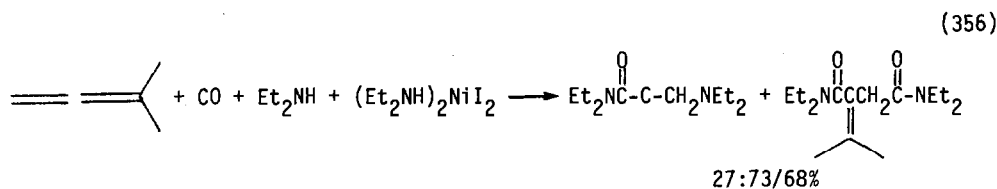
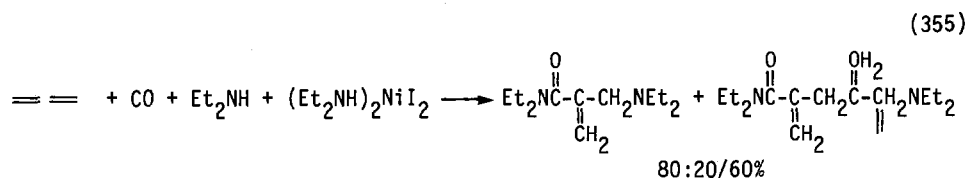
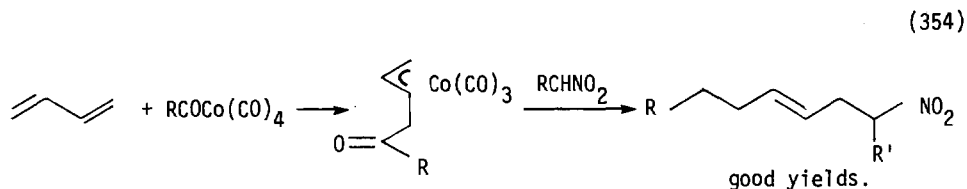

The effects of substituents on the rate of carbonylation of *o*-palladated imines of substituted benzaldehydes was studied (equation 358) [395]. *o*-Palladated benzyl amines also underwent carbonylation and isonitrile insertion (equation 359) [396] as well as alkylation by  $\alpha$ -haloesters. *N*-vinylphthalimides were hydroformylated. The regioisomeric distribution depended on the catalyst used (equation 369) [397]. Cobalt hydroformylation catalysts were electrochemically generated (equation 36) [398]. Rhodium carbonyl clusters catalyzed the carbonylation of olefins and acetylenes, and the cross hydrocarbonylation of these same substrates [399].

(358)

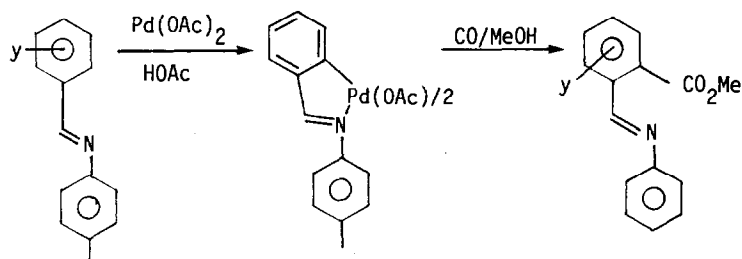

$y = 5' \text{ OMe}, 5' \text{ Me}, 5' \text{ Cl}, 4' \text{ Me}, 4' \text{ H}, 4' \text{ NO}_2, 4' \text{ Cl}, 4' \text{ OMe}, 5' \text{ NO}_2$

Electron withdrawing gp slows CO insertion

(359)

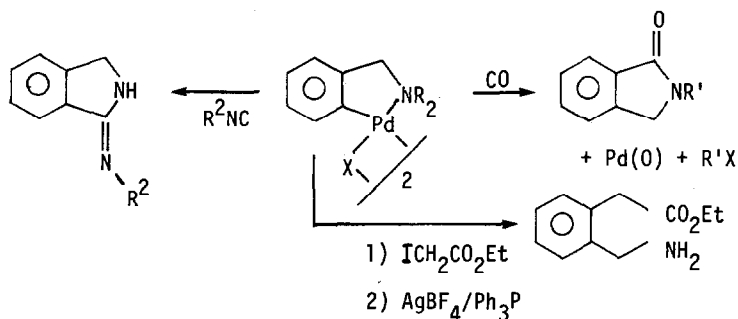

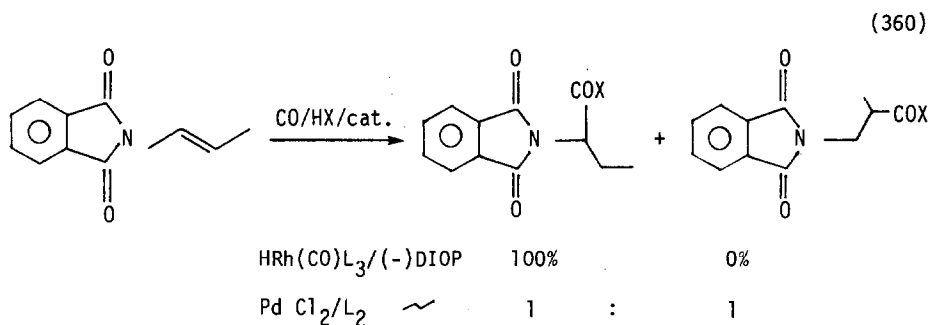

(361)

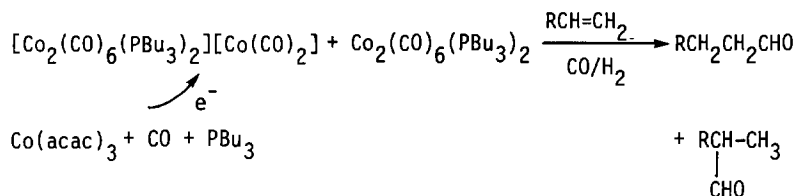



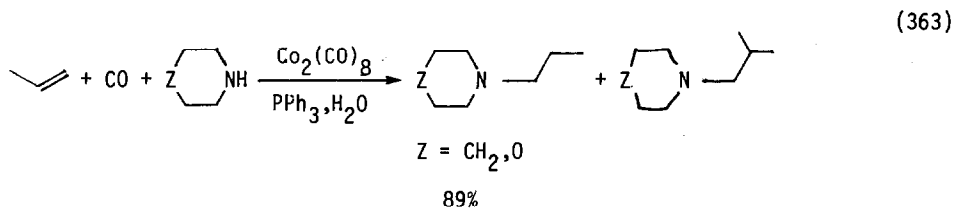
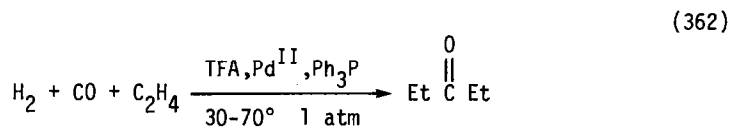

Ethylene was converted to diethylketone by reaction with hydrogen and carbon monoxide in the presence of palladium(II) catalysts (equation 362) [400], and catalysts made by the pyrolysis of dicobalt octacarbonyl on carbon [401]. Propylene was aminomethylated with piperidine or morpholine with cobalt catalysts (equation 363) [402]. Polymer-bond catalysts for alkoxy carbonylation and for asymmetric hydroformylation have been developed [403].

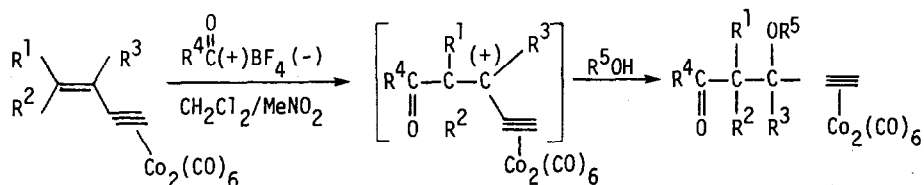

Cobalt-complexed enynes underwent clean acylation by acylium ions (equation 364) [404]. Dicobalt octacarbonyl promoted the cyclization of allyl propargyl ethers to bicyclic compounds (equation 365) [405]. The same complex catalyzed the cocyclization of acetylene and carbon monoxide to low yields of bicyclic compounds (equation 366) [406]. Prostaglandins were made by the reaction of olefins with cobalt-alkyne complexes (equation 367) [407]. Other cyclic systems were prepared by this same reaction (equation 368) [408].

(364)

R<sup>1</sup> = HR<sup>2</sup> = H (CH<sub>2</sub>)<sub>3</sub>, (CH<sub>2</sub>)<sub>4</sub>R<sup>3</sup> = H, MeR<sup>4</sup> = Me, iPr, , ,  1-adamantylR<sup>5</sup> = Me, H

(365)

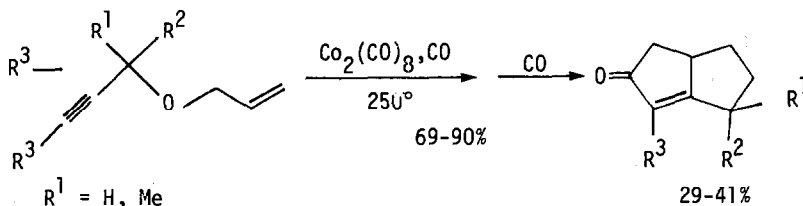
R<sup>1</sup> = H, MeR<sup>2</sup> = H, MeR<sup>3</sup> = H, Me  OTHP

29-41%

(366)

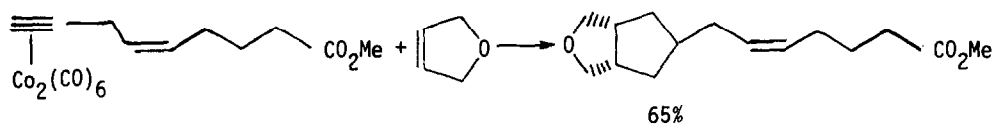
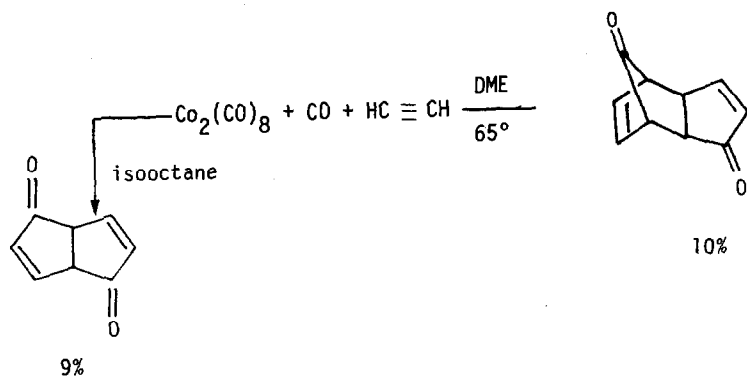

(367)

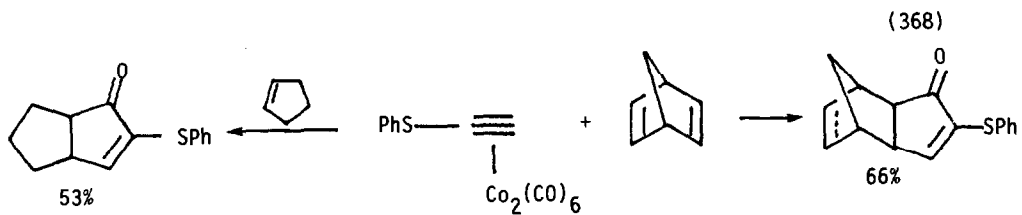
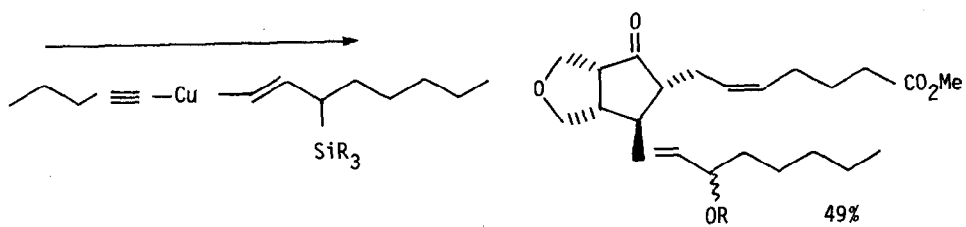

Cyclohexadiene iron complexes underwent Friedel-Crafts acylation when heated with acid halides and aluminum trichloride (equation 389) [409]. Oxidation of  $\sigma$ -vinyliron complexes led to CO insertion to give  $\sigma$ -acyliron species (equation 320) [410]. Alkylation of cyclohexadieneiron complexes with nitrite stabilized carbanions and carbon monoxide produced new acyliron complexes (equation 371) [411]. Iron pentacarbonyl cyclodimerized norbornadienes with CO incorporation (equation 372) [412]. Cyclooctene and 2-butyne were cyclized to bicyclic ketone complexes (equation 373) [413].

(369)

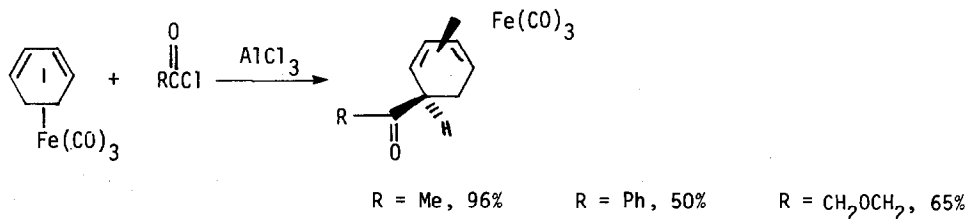

(370)

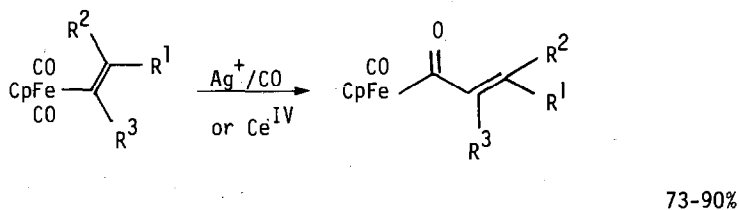

(371)

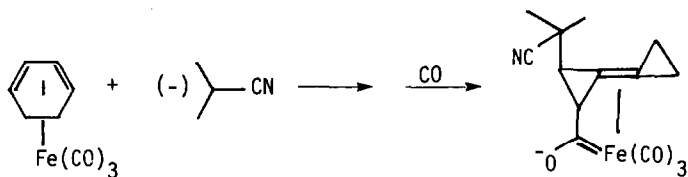

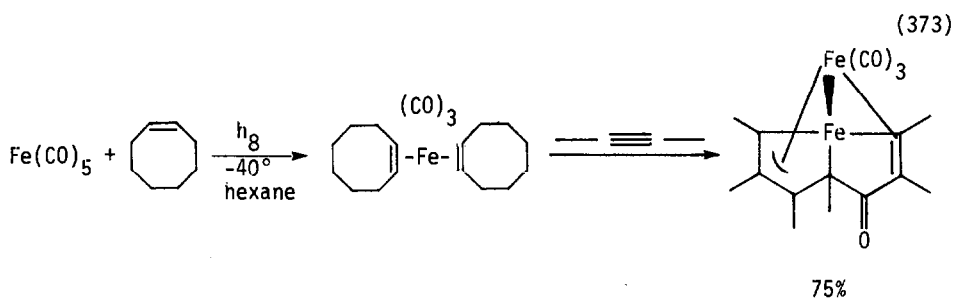
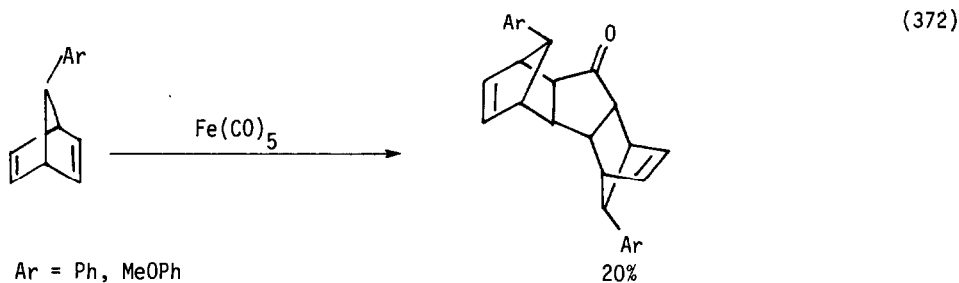

Alkynes were converted to maleamides by reaction with carbon monoxide and diethylamine in the presence of nickel(II) catalysts (equation 374) [414]. Dienes were dicarboxylated by nickel (0) complexes in the presence of carbon dioxide (equation 375) [415]. Alkynes and carbon dioxide were converted to a number of interesting organic compounds by nickel (0) catalysts (equation 376) [416].

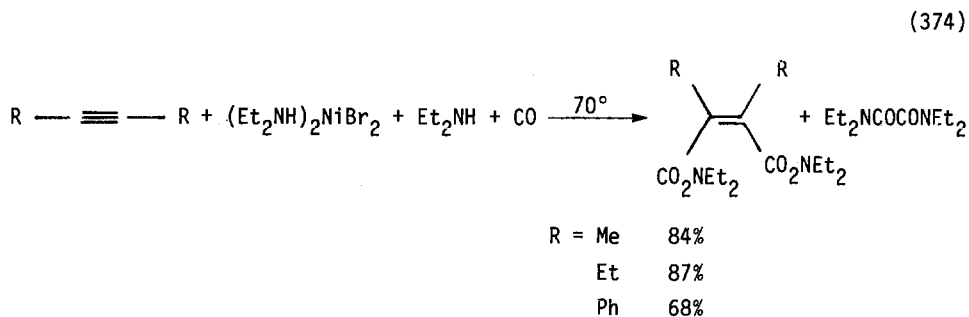

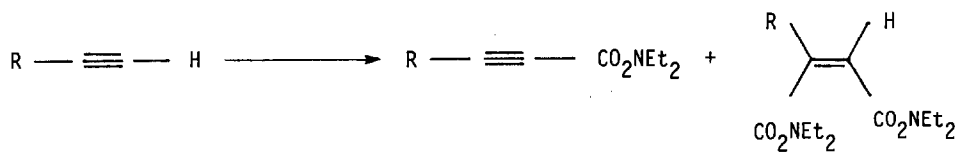

R = Me	46%	25%
Et	47%	28%
Bu	12%	40%

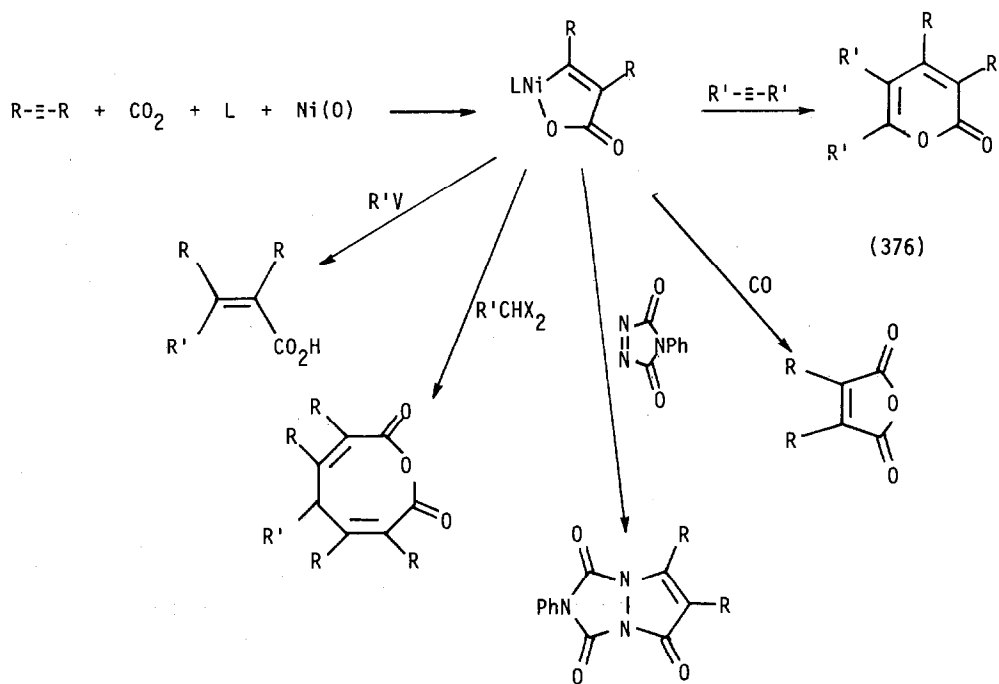
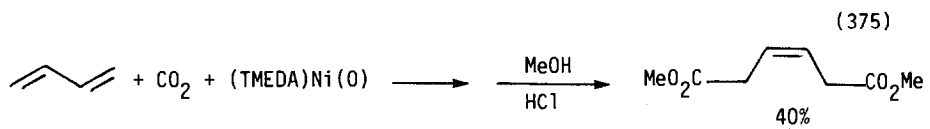



(377)

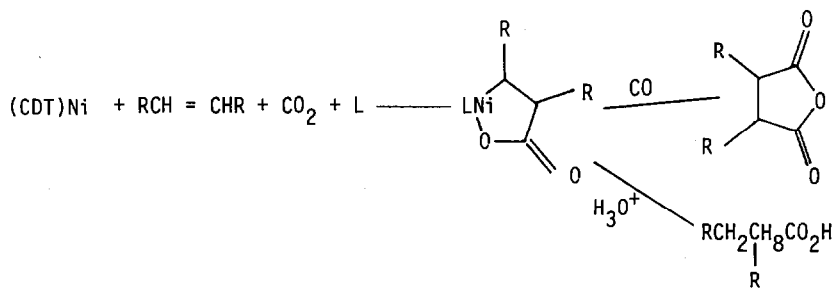

Rhodium(I) complexes catalyzed the intramolecular hydroacylation of olefins to give cyclic ketone (equation 378) [417] (equation 379) (equation 389) [415]. Homoallylic alcohols were cyclocarbonylated to lactones using rhodium(II) catalysts (equation 382) [420]. Molybdenum, tungsten and cobalt catalyzed the addition of acetaldehyde to methyl acrylate to give lactones (equation 383) [421]. Cyclocarbonylation reactions of alkynes and alkenes has been reviewed (251 references) [422]. Methyl acrylate was hydrocarbonylated by cobalt carbonyl catalysts [423]. Alkylmanganese complexes acylated olefins under high carbon monoxide pressures (equation 384) [424]. Group VI metal carbonyls reacted with zirconium diene complexes to produce new carbene complexes (equation 385) [425].

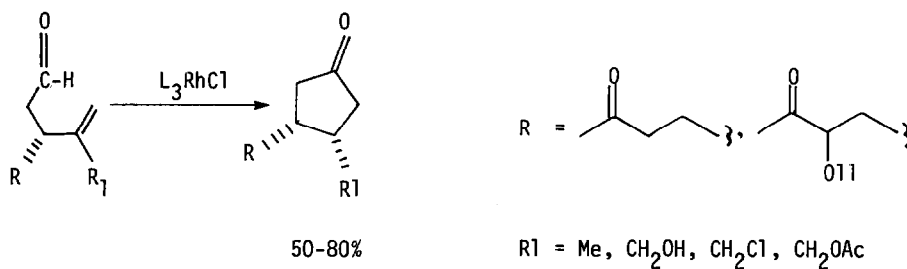

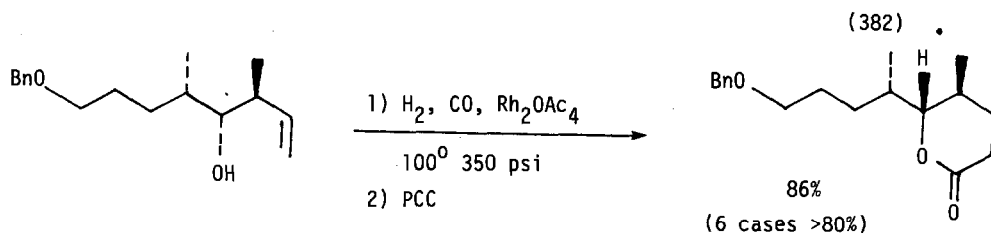
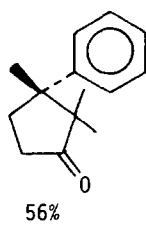
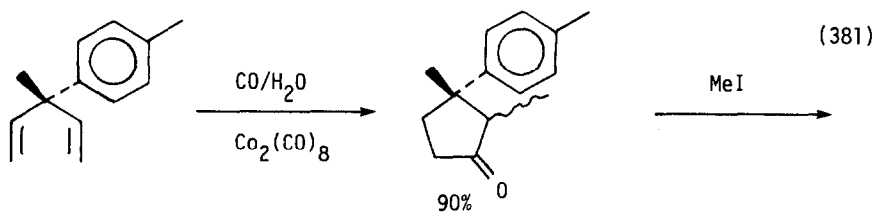
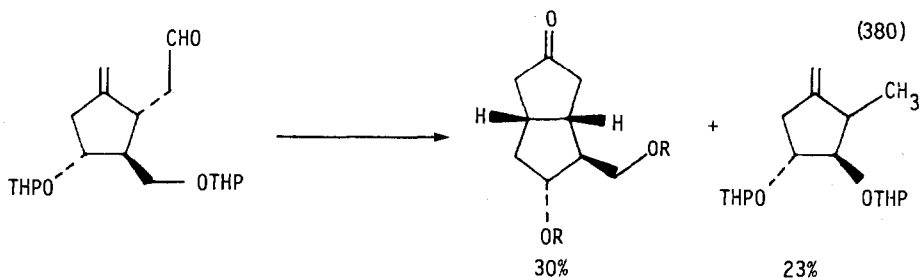
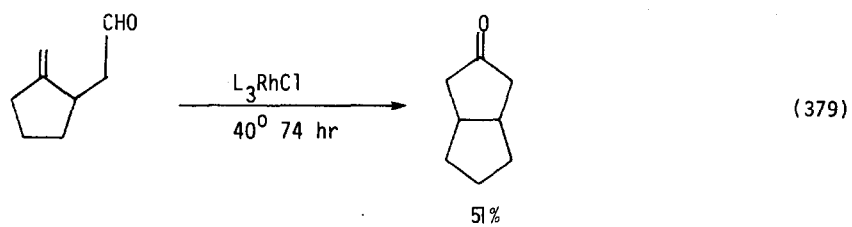

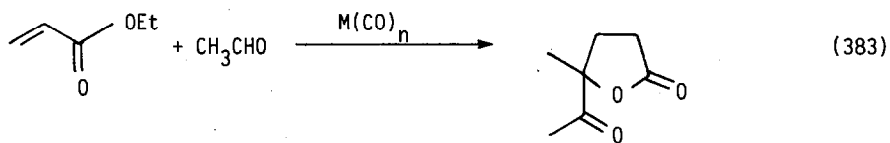

M = Co, Mo, W

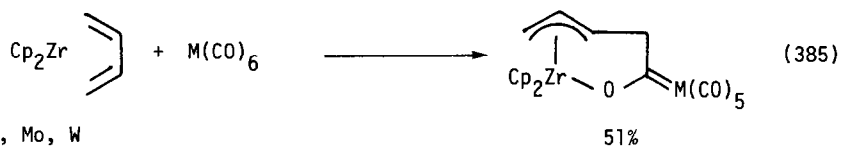
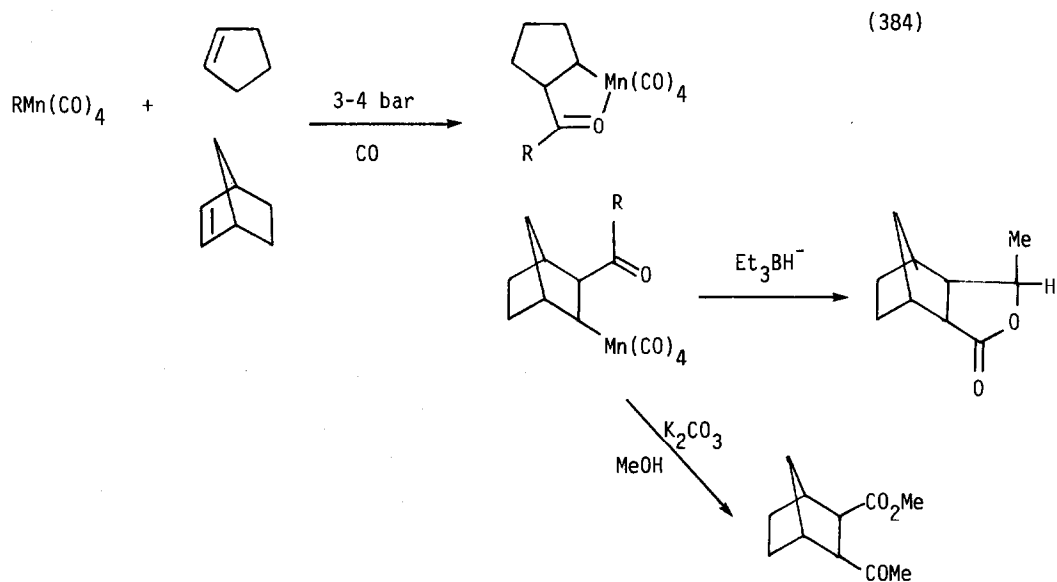

M = Cr, Mo, W

## 2. Carbonylation of Halides

Palladium(0) catalyzed oxidative addition/carbonylation of aryl halides has been used to synthesize a number of important heterocycles (equation 386) [426] [427], (equation 387) [428]. Divinylketones were prepared by the palladium catalyzed coupling of vinyl halides with vinyl tin reagents (equation 388) [429]. Diallylketones were prepared in a similar way (equation 389) [430].

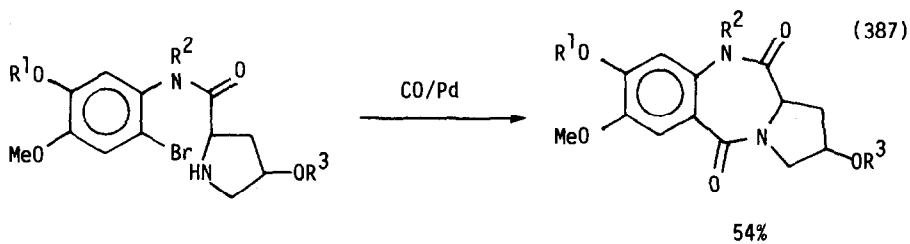
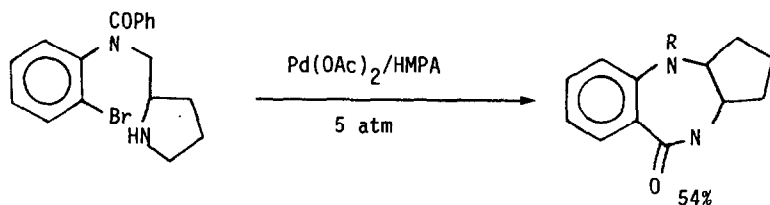
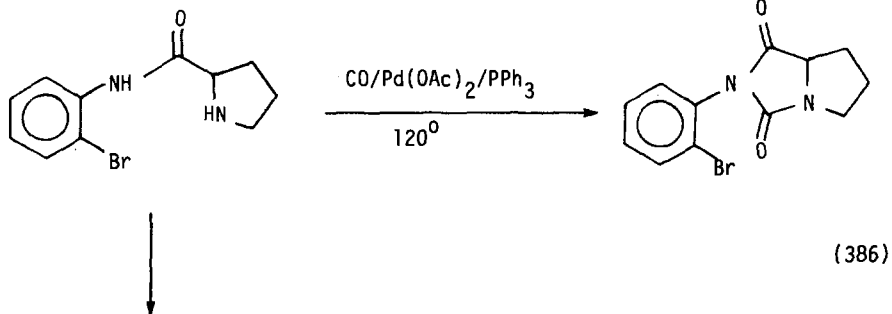

→ → SEN 215

$R^1 = \text{Ts}$   
 $R^2 = \text{PhCO}$   
 $R^3 = \text{OAc}$

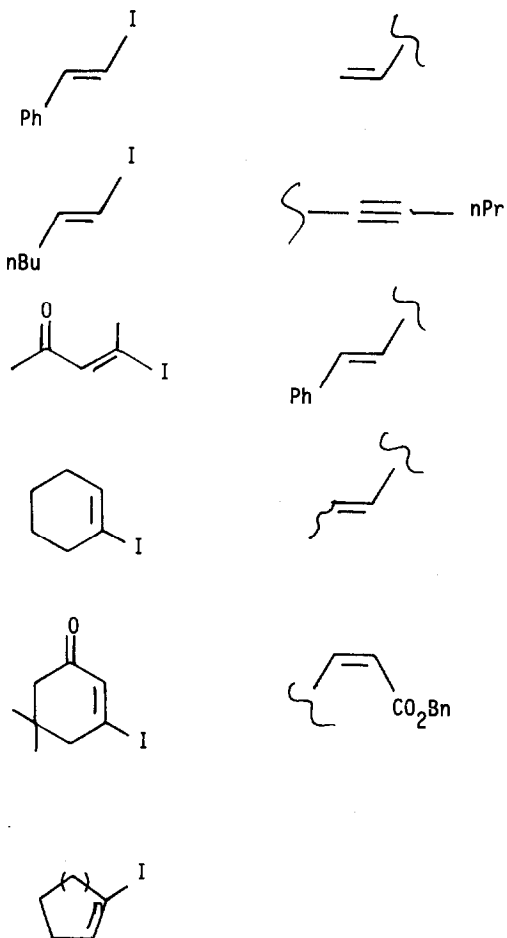
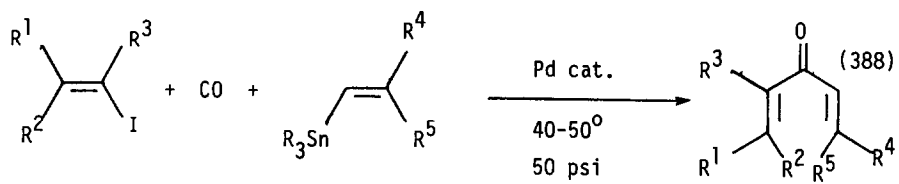

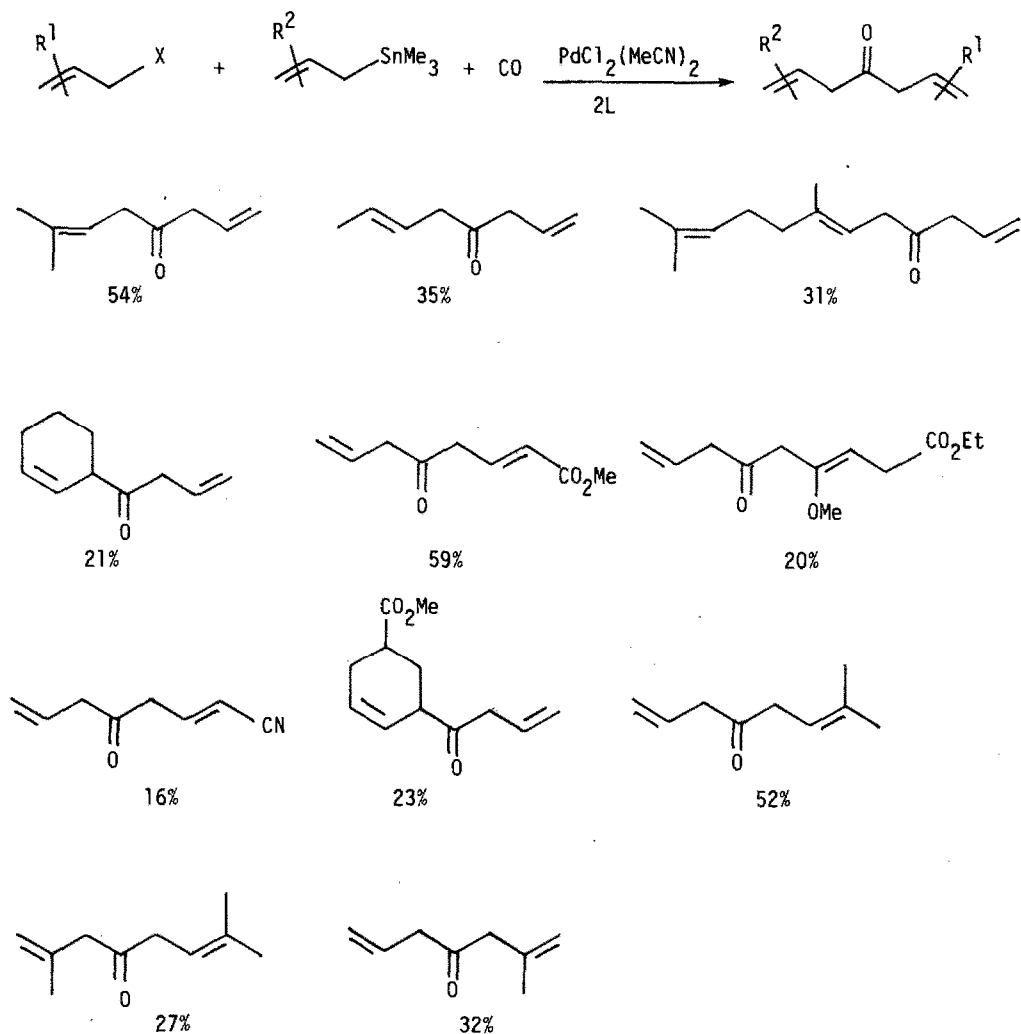

Heteroaromatic halides were converted to esters in a palladium-catalyzed carbonylation process (equation 390) [431]. The kinetics of a related process have been studied [432]. Aryl halides were converted to aldehydes using palladium(0) catalysts and polymethylhydrosiloxane as a hydrogen donor (equation 391) [433]. Alkynes were acylated by aryl halides and carbon monoxide in the presence of palladium(0) catalysts (equation 392) [434].

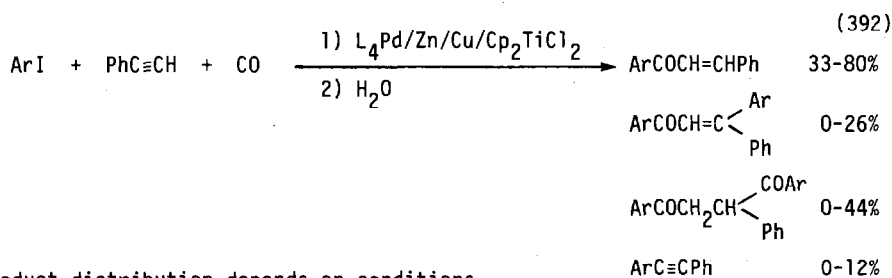
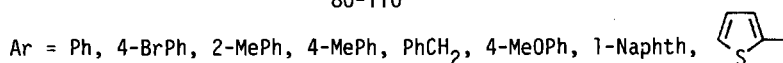
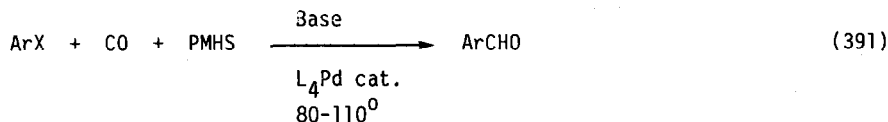
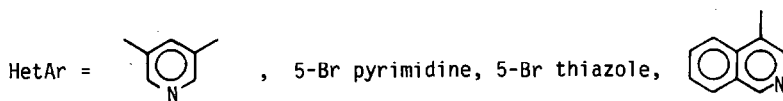
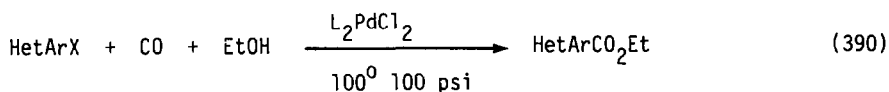

Product distribution depends on conditions.

Rhodium(I) complexes catalyzed the conversion of aryl and benzyl halides to esters using aluminum alkoxides (equation 393) [435] or boron alkoxides (equation 394) [436]. Cobalt carbonyl catalyzed the alkoxy carbonylation of monosubstituted methyl chlorides [437].

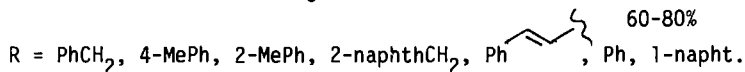
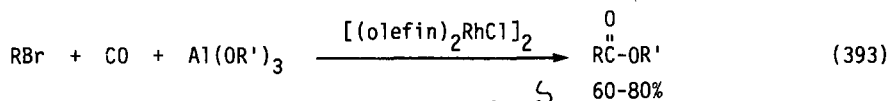

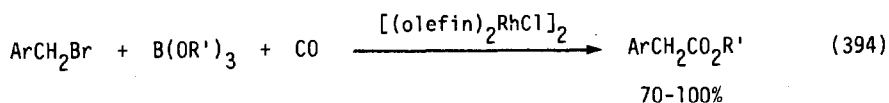

Ar = Ph, 4-MePh, 3-MePh, 2-BrPh, 2-Naphth

R' = Et, Bu, iPr, tBu, nPr

Iron pentacarbonyl converted benzyl bromide and n-butylbromide to esters under phase-transfer conditions [438]. Nickel carbonyl coupled organomercuric halides to symmetrical ketones (equation 395) [439]. Benzyl halides were coupled to dibenzyl ketones by iron pentacarbonyl under phase transfer conditions (equation 396) [440].

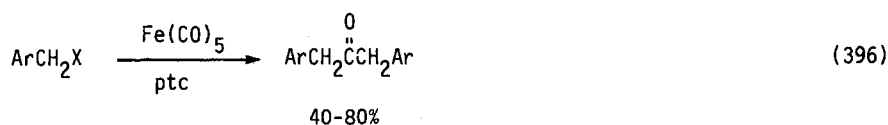
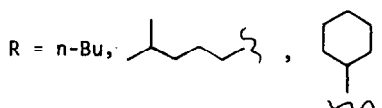

ArCH<sub>2</sub>X = PhCH<sub>2</sub>Br, PhCH<sub>2</sub>Cl, ptoICH<sub>2</sub>, 4-BrPhCH<sub>2</sub>, β-naphthCH<sub>2</sub>

### 3. Carbonylation of Nitrogen Compounds

Nitroarenes were reductively carbonylated to carbamates by catalysts containing PtCl<sub>2</sub>(PPh<sub>3</sub>)<sub>2</sub>, SnCl<sub>4</sub>, and triethylamine [441][442]. Similar chemistry was accomplished using platinum-iron catalyst systems (equation 397) [443] and ruthenium carbonyl catalysts (equation 398) [444]. 2,6-Dinitrotoluene was carbonylated using palladium and rhodium catalysts [445]. Nitrobenzene was carbonylated to phenyl isocyanate by palladium catalysts [446][447][448].



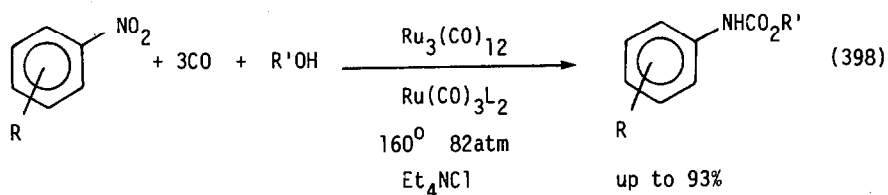
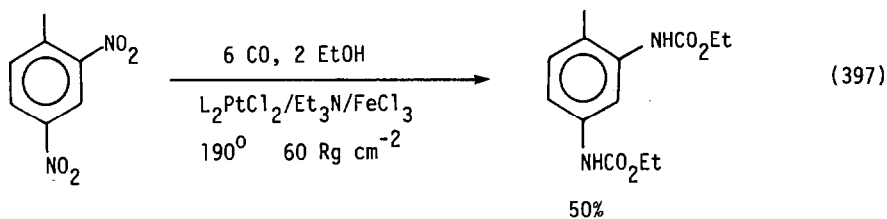

Aniline was converted to carbamates and ureas by carbon monoxide in the presence of a number of catalysts (equation 399) [449]. Palladium black catalyzed the carbonylation of amines to carbamates (equation 400) [450]. Palladium-catalyzed double carbonylations giving pyruvyl compounds was shown not to proceed via pyruvyl complexes, but rather by reductive elimination from bis-acyl complexes (equation 401) [451], (equation 402) [452], (equation 403) [453].

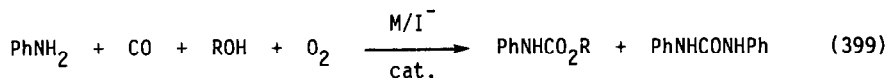

$\text{M/I}^- = \text{Ru black/I}^-; 5\% \text{ Rh/C I}^-; \text{RhI}_3/\text{CsI}; \text{Pd black/I}^-; 2\% \text{ Pd/SiO}_2\text{I}^-; \text{IrCl}_2/\text{I}^-; 5\% \text{ Pt/C I}^-$

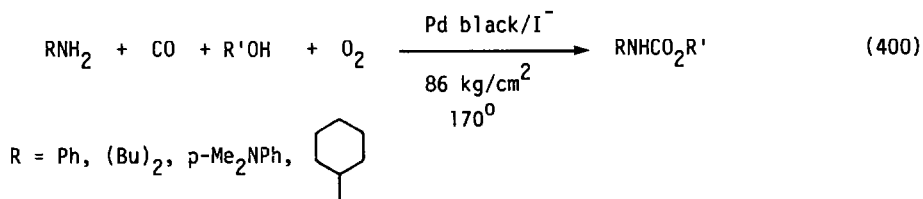

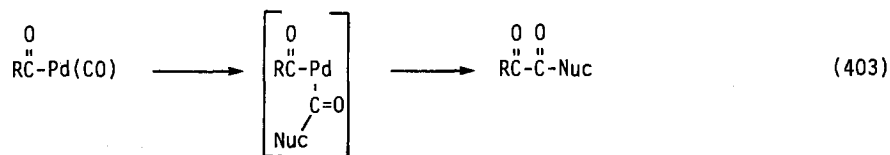
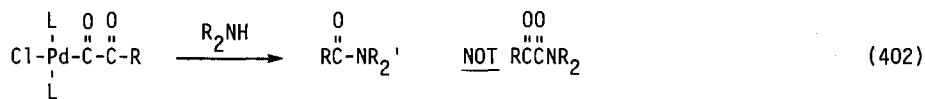
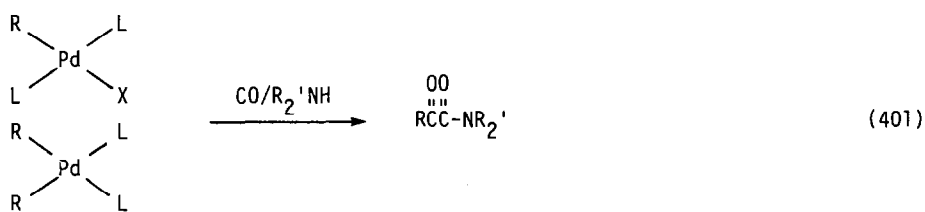

Phenyl azide (equation 404) and phenylazirine (equation 405) were carbonylated to a number of products by  $\text{Fe}_2(\text{CO})_9$  [454]. Aziridines were ring-opened with carbonylation by a number of hydridometal carbonyls (equation 406) [455].

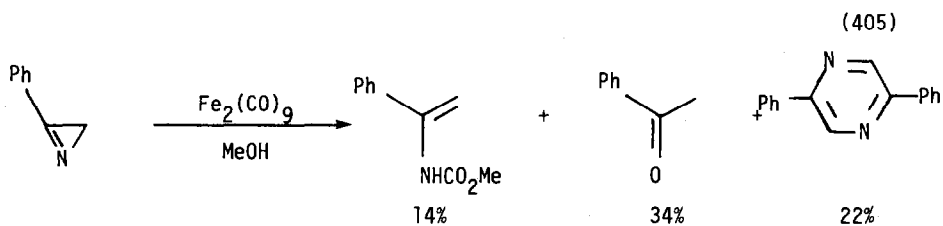
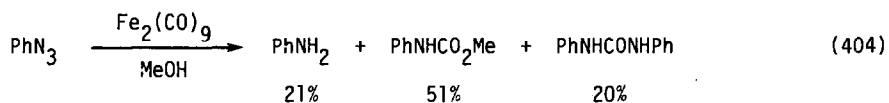

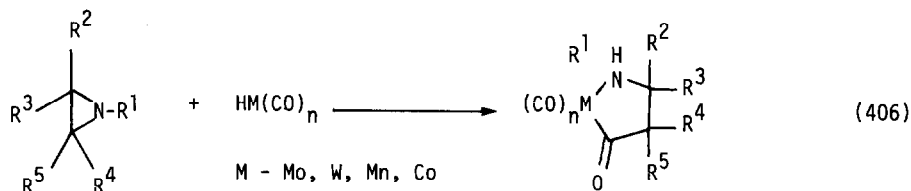

$\text{R}^1 = \text{H, Me, tBu}$

$\text{R}^2 = \text{H, Ph}$

$\text{R}^3 = \text{H, Ph}$

$\text{R}^4 = \text{H, Me, Et}$

$\text{R}^5 = \text{H, Me}$

#### 4. Carbonylation of Oxygen Compounds

Carbonylation of methyl acetate to acetic anhydride and applications of the reaction has been reviewed (75 references) [456]. The mechanism of oxidative carbonylation of alcohols using palladium catalysts has been studied [457]. Allyl carbonates were converted to  $\beta, \gamma$ -unsaturated esters by palladium catalysts (equation 407) [458]. Vinyl triflates and vinyl tin reagents were coupled with carbonylation by palladium(0) catalysts (equation 408) [459]. Capnellane was synthesized using this chemistry (equation 409). Cyclobutanones were converted to cyclopentanone silyl enol ethers by alkyl silanes and cobalt catalysts (equation 410) [460]. Aldehydes were carbonylated to  $\alpha$ -hydroxyaldehydes by manganese hydride complexes (equation 411) [461].

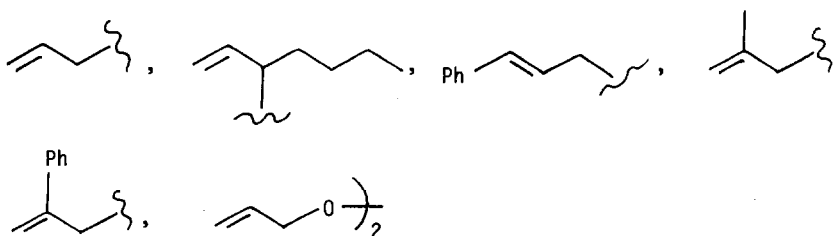
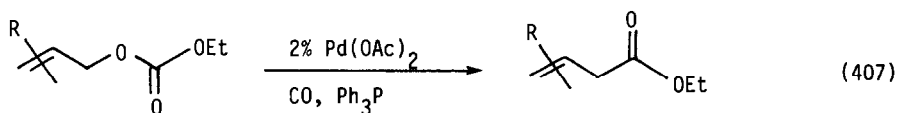

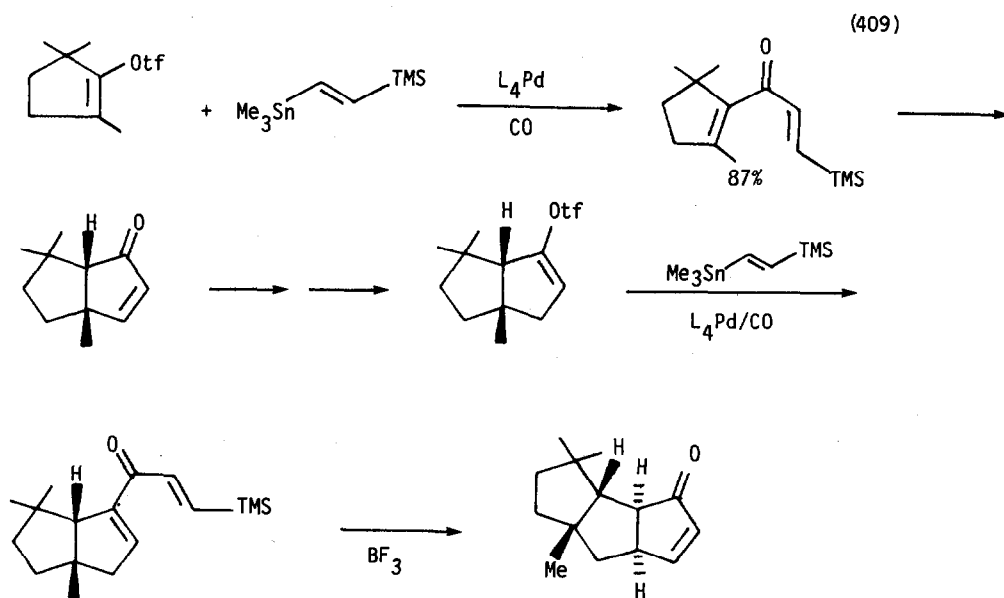
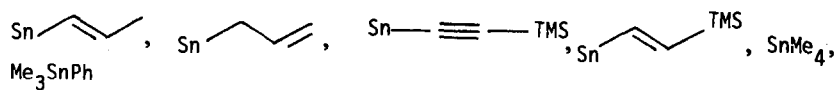
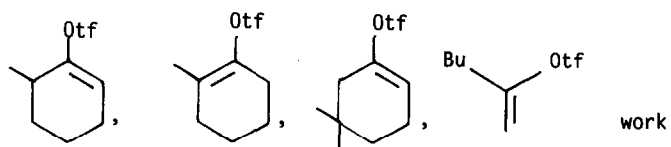
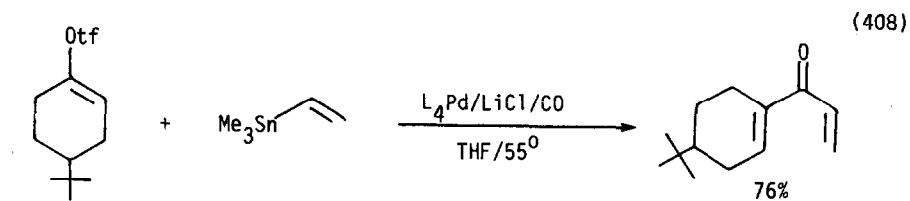

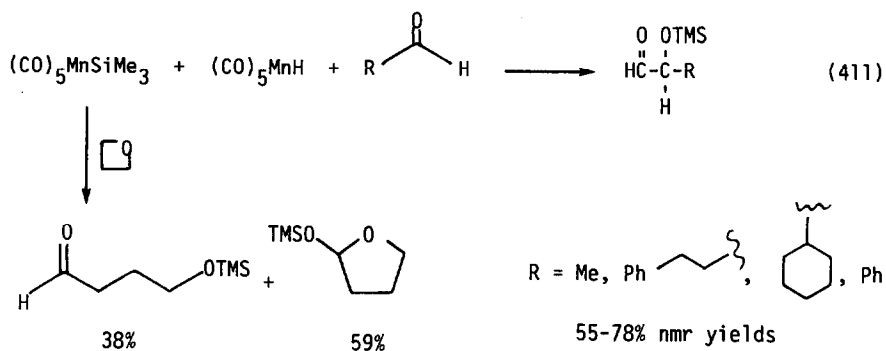
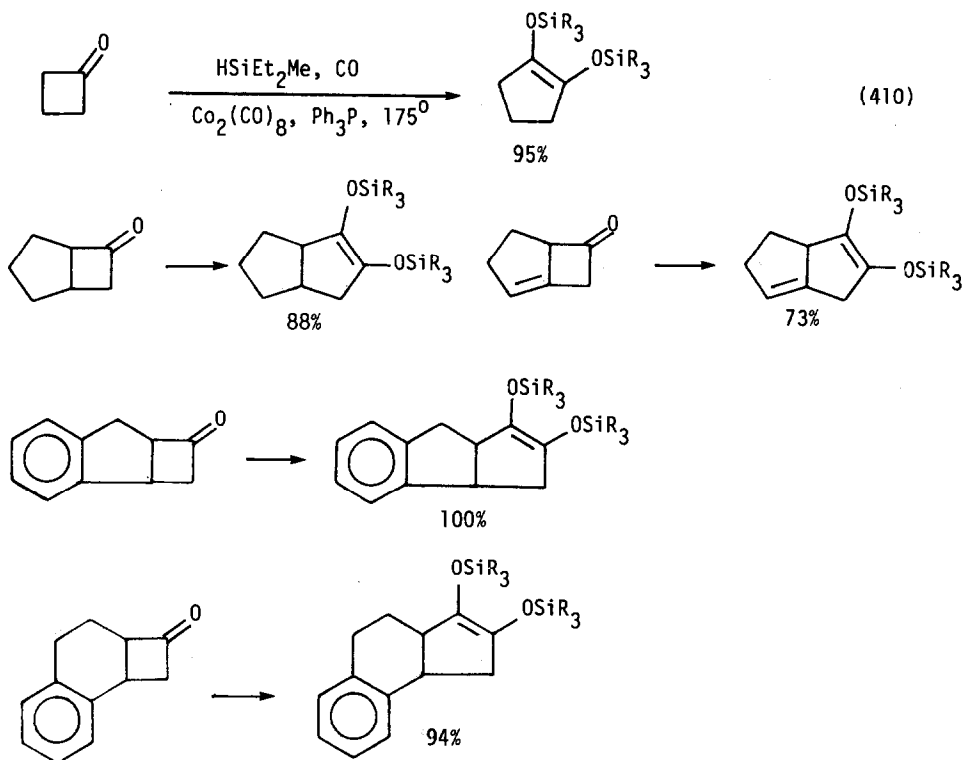

## 5. Miscellaneous Carbonylations

Synthetic applications of some metal carbonyl complexes has been reviewed (38 references) [462], as has carbonylation of zirconocene complexes (49 references) [463]. Palladium salts catalyzed the carbonylation of diaryliodonium salts to diaryl ketones and  $\alpha$ -diketones [464]. Aryl diazonium salts were converted to aryl aldehydes by carbon monoxide, triethylsilane and palladium(II) acetate (equation 412) [465]. Rhodium(I) carbonyl complexes carbonylated cage compounds (equation 413) [466]. A stable rhodium alkyl-acyl complex has been isolated (equation 414) [467].

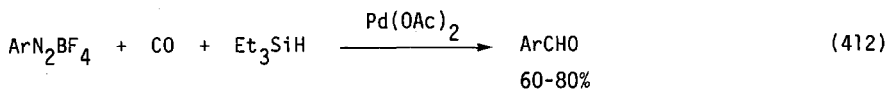

Ar = 4-BrPh, 2-MePh, 3-MePh, 4-MePh, 2-PhPh, 2-ClPh, 3-ClPh, 4-ClPh, 4-BrPh, 4-COMePh, 4-EtO<sub>2</sub>CPh, 3-NO<sub>2</sub>Ph, 4-NO<sub>2</sub>Ph

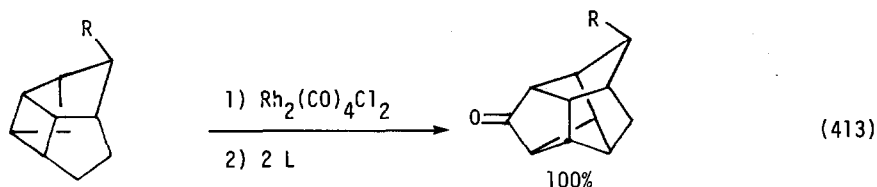

R = H, OH, OAc, Cl

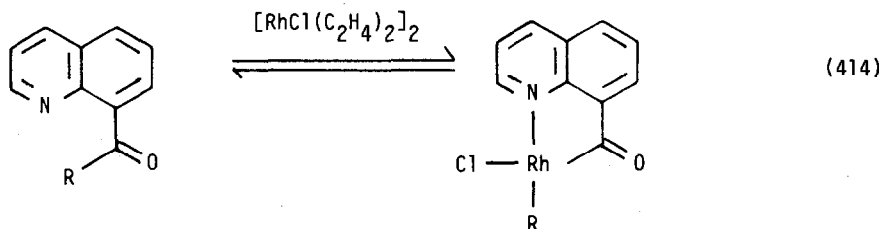

R = PhCH<sub>2</sub>, PhCD<sub>2</sub>, PhC≡C, Me, Et

## 6. Decarbonylation Reactions

Decarbonylation reactions using transition metal complexes have been reviewed (91 references) [468], as has carbonylation and decarbonylation cycles of alkyl complexes in catalytic cycles (32 references) [469]. The steric and electronic influences on the reaction mechanism of the catalytic decarbonylation of acid halides using rhodium carbonyl complexes was studied [470].

## 7. Reactions of Carbon Dioxide

Allyl esters were decarboxylated by palladium(II) acetate (equation 415) [471]. The activation of carbon dioxide by metal complexes has been reviewed [472]. Palladium(II) salts catalyzed the carboxylation of arenes (equation 416) [473] and nickel(II) salts the carboxylation of aryl halides under reducing conditions (equation 417) [474]. Carbon dioxide inserted into a manganese-carbon bond (equation 418) [475].

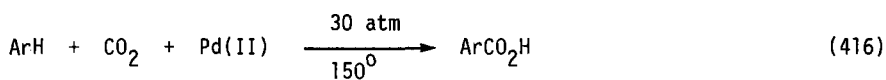
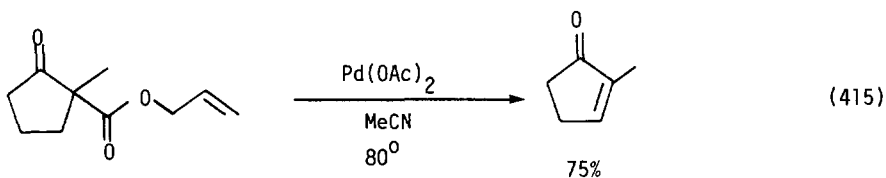

ArH = PhH	120%	Based on Pd
PhOMe	125%	
ClPh	40%	

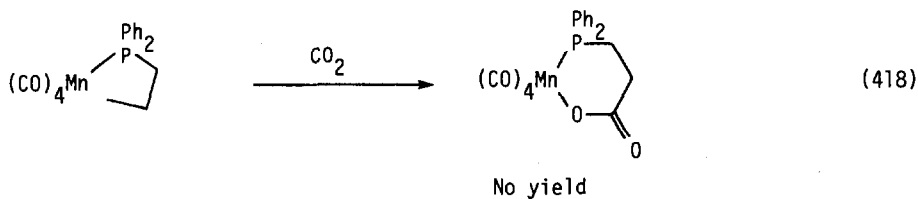
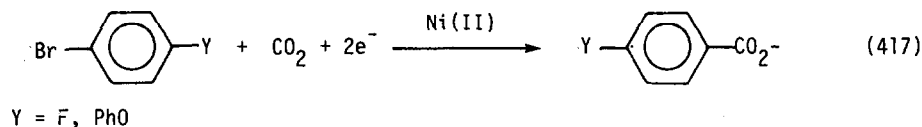

Nickel(0) catalyzed the carboxylation of conjugated dienes (equation 419) [476] (equation 420) [477]. Methylene cyclopropane was cooligomerized with carbon dioxide by palladium(0) complexes (equation 421) [478]. Allyl carbonates were decarboxylated by rhodium or cobalt catalysts (equation 422) [479]. Phenylacetic acid was decarboxylated to toluene by copper oxide in acetonitrile [480].

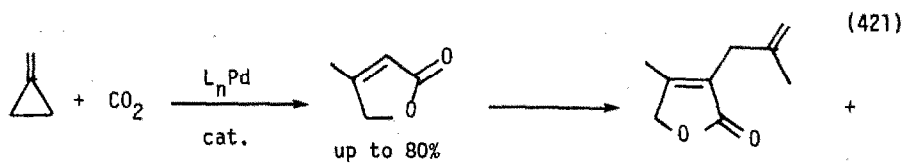
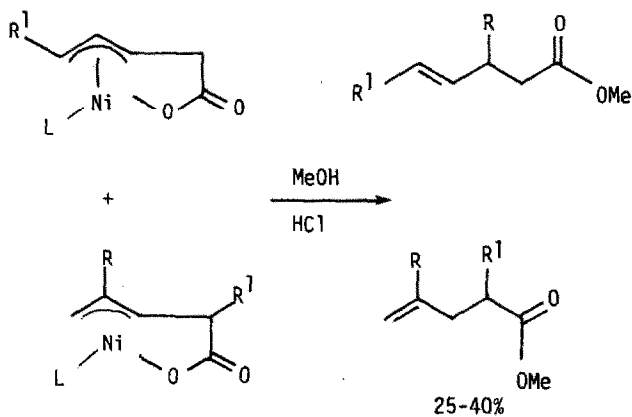
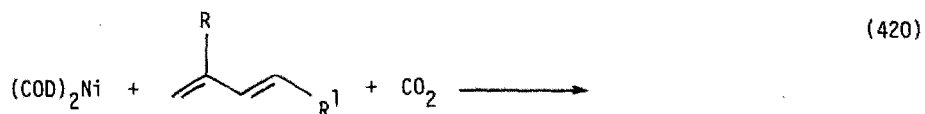
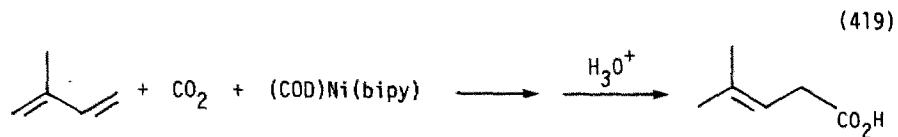

(equation 421 continued on next page)



(421 continued)

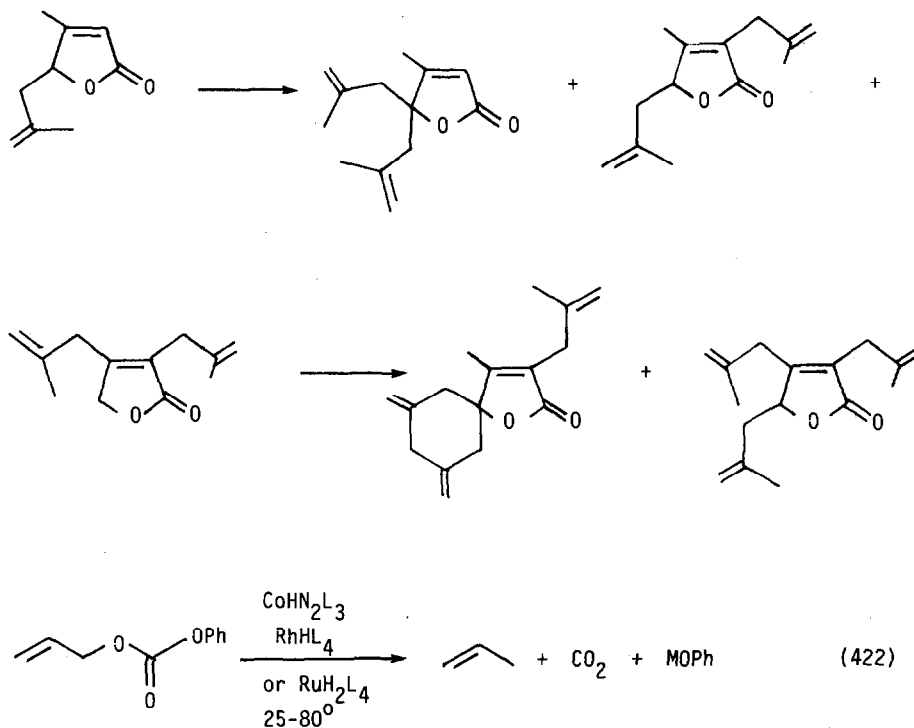

#### D. Oligomerization

Nickel-surface complexes in x-type zeolite or on silica catalyzed the dimerization of olefins [481]. Anionic rhodium(I) complexes heterogenized on the surface of silica gel catalyzed the cyclodimerization of norbornadiene [482].  $\pi$ -Allyl-nickel halides heterogenized on alumina catalyzed the dimerization of propylene [483]. Nickel(0) complexes catalyzed the dimerization and codimerization of cyclopropenes (equation 423) [484]. Ethylene was oligomerized by silica or alumina supported nickel(II) complexes [485]. Copper and iron powder in solvents dimerized allyl-vinyl type chlorides [486].

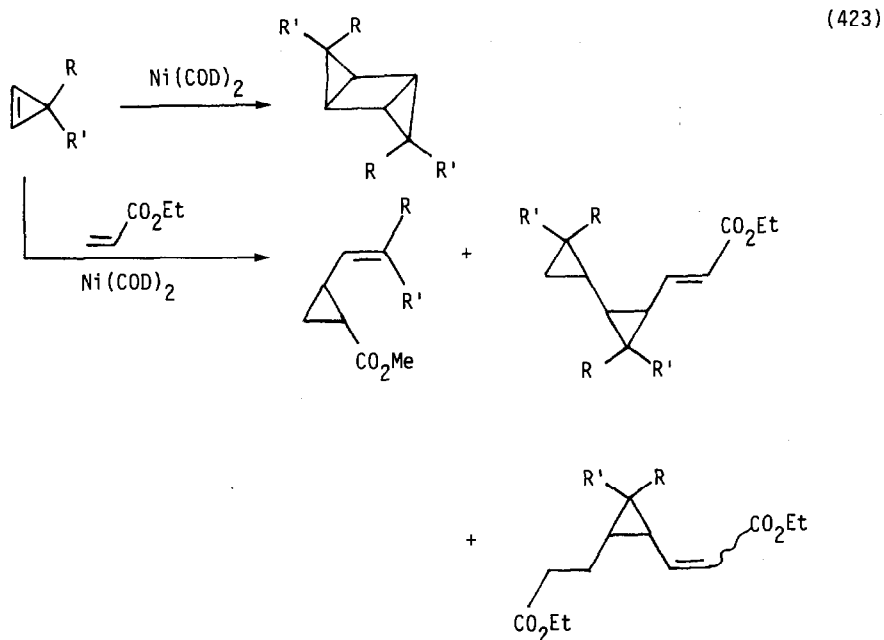

Bisphosphine- $\pi^3$ -allylpalladium cationic complexes catalyzed the dimerization of acrylate [487], (equation 424) [488]. A rhenium dimer was a slow catalyst for olefin dimerization (equation 425) [489]. Nickel diethyldithiocarbamate/diethylaluminum chloride mixtures catalyzed the codimerization of styrene with ethylene [490].

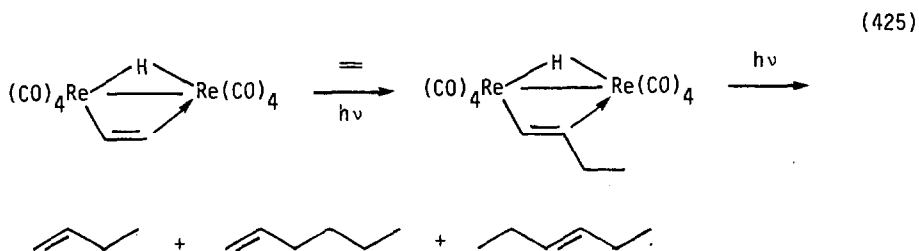
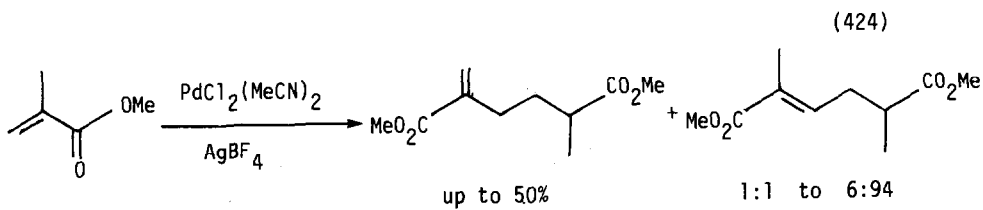

Palladium(0) complexes catalyzed the dimerization and codimerization of mono-substituted acetylenes [491]. "The Synthesis of High Polymers from Substituted Acetylene-Exploration of Mo and W-Based Catalysts" was the title of a review [492]. Nickel complexes catalyzed the polymerization of propargyl halides and alcohols (equation 426) [493].

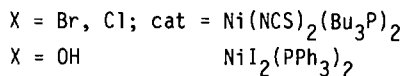
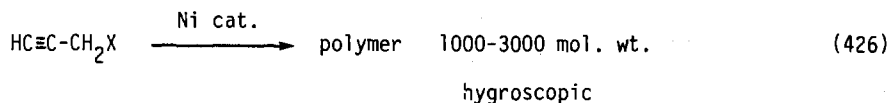

Isoprene was dihydrodimerized by nickel(II) acetylacetonate/ligand/Li alkoxide catalysts [494]. Nickel(0) complexes catalyzed the dimerization of butadiene to linear dimers rapidly under mild conditions (equation 427) [495]. Isoprene was dimerized by  $\eta^3$ -allylpalladium catalysts (equation 428) [496]. Chiral iron diimine complexes catalyzed the dimerization of butadiene to vinylcyclohexene with low ee (equation 429) [497]. Osmium carbonyl clusters catalyzed the oxidative dimerization of bicyclic dienes (equation 430) [498]. Copper(I) triflate catalyzed the photodimerization of 1,3,5-hexatriene (equation 431) [499]. Butadiene telomerized with carbon dioxide in the presence of palladium(II) complexes (equation 432) [500]. Allene was converted to dienylalcohols by palladium(0) catalysts (equation 433) [501].

(427)

94-98 selectively

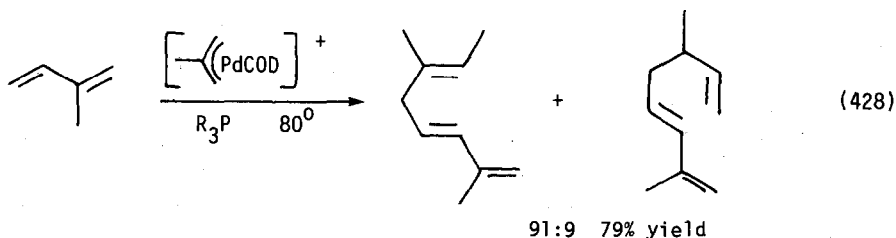
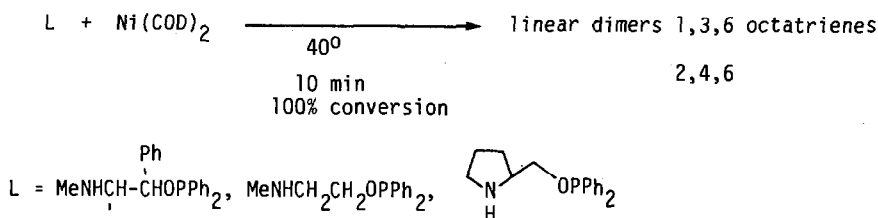

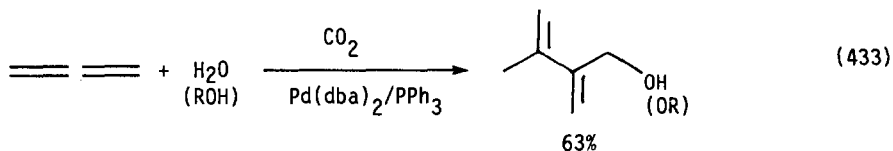
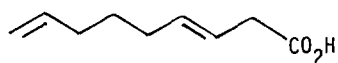
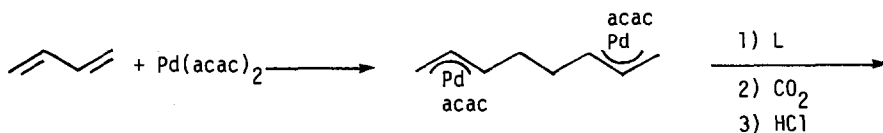
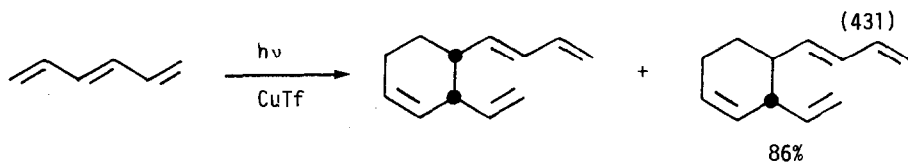
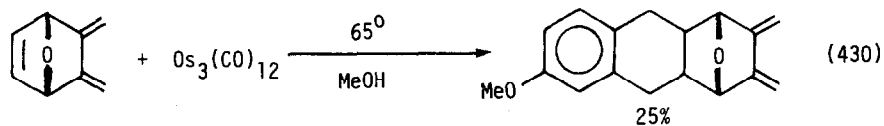

Allylic chlorides and chromium(III) chloride promoted the rhodium(I) catalyzed iodimerization of butadiene with 2,7-octadienes [502]. The mechanism of the linear and cyclic iodimerization of 1,3-dienes with ethylene in the presence of  $n^5$ -cyclopentadienyltitanium catalysts has been studied [503]. Cobalt complexes catalyzed the iodimerization of myrcene with methyl acrylate (equation 434) [504]. Organic halides promoted the rhodium(III) catalyzed iodimerization of butadiene with octadienylacetates (equation 435) [505]. Nickel(0) complexes catalyzed the codimerization of butadiene with vinyl silanes (equation 435) [506].

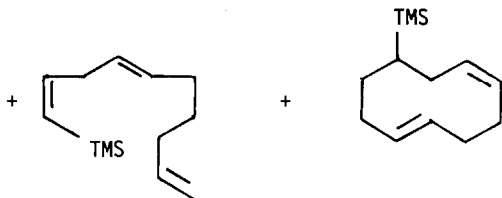
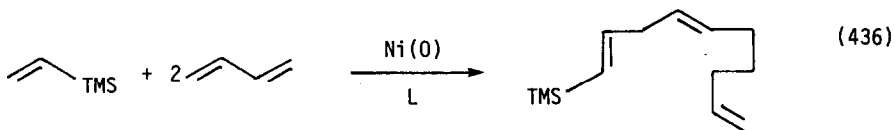
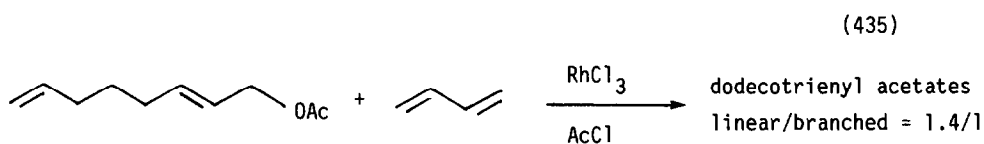
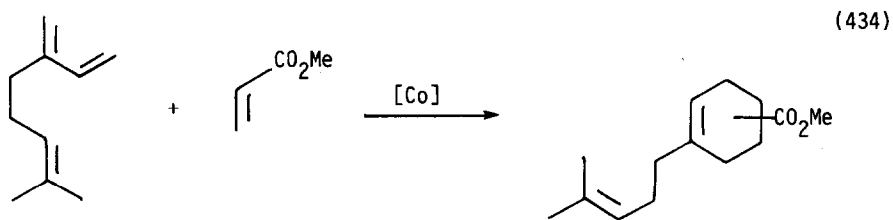

The relation between the nature of the components of Ti containing Ziegler Systems and their activities and stereospecificities in the polymerization of dienes has been reviewed (153 references) [507], as has polymerization and copolymerization of dienes under the influence of transition metal complexes (125 references) [508] and the metathesis reaction in polymer chemistry (160 references) [509]. The cyclootrimerization of 1,3-butadiene on complex organometallic catalysts in the presence of dimethyl sulfoxide has been studied [510]. Titanium(IV) complexes catalyzed the cyclootrimerization of butadiene (equation 437) [511], while  $n^3$ -allylnickel complexes catalyzed the 1,4-oligomerization of butadiene [512].

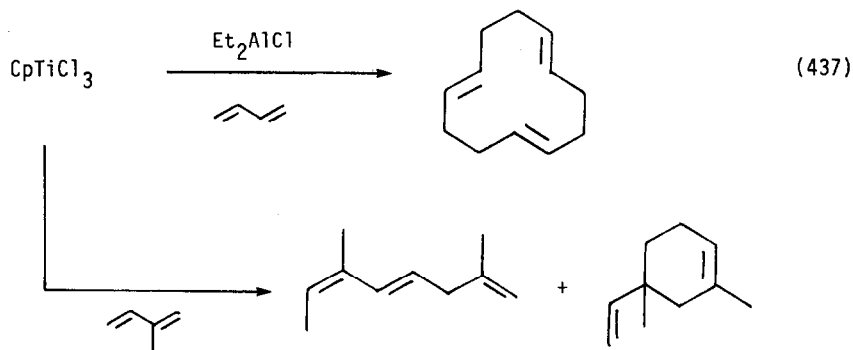

Butadiene was telomerized with carbon dioxide to form octadienylcarboxylate esters. These were used in a synthesis of the brevicomins (equation 438) [513]. Rhodium(I) complexes telomerized butadiene with carbon dioxide (equation 439) [514], while palladium catalyzed the telomerization of isoprene with methanol (equation 440) [515], butadiene with formamide (equation 441) [516], butadiene with cyclic ketones (equation 442) [517], isoprene with cyclic ketones (equation 443) [518], and butadiene with aminopyridines (equation 444) [519]. Manganese and iron carbonyls telomerized 1-hexene with carbon tetrachloride and methyl chloroacetate [520]. Cationic palladium(II) complexes catalyzed the codimerization of ethylene and carbon monoxide (equation 445) [521]. Cobalt carbonyl catalysts on alumina converted olefins and carbon monoxide to mixed hydrocarbons [522].  $\alpha$ -Chloroimines were dimerized by methyl copper (equation 446) [523].

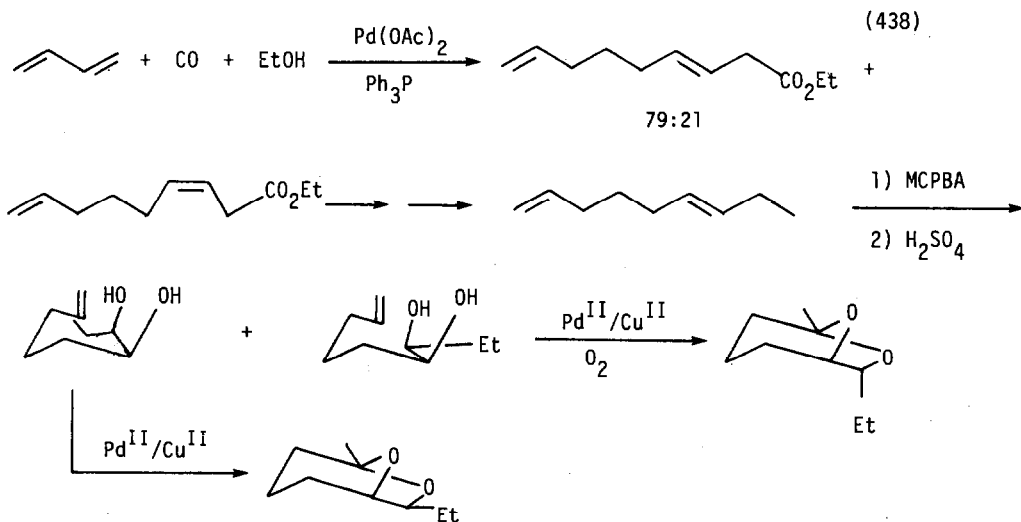

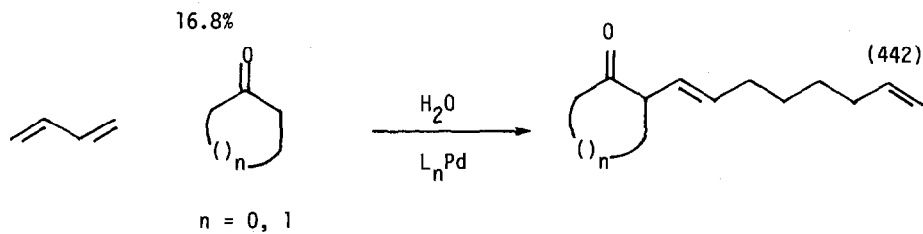
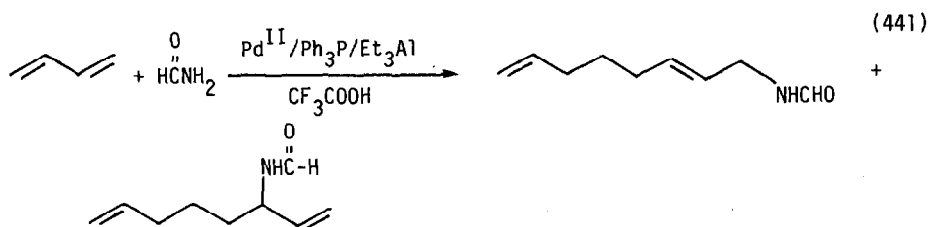
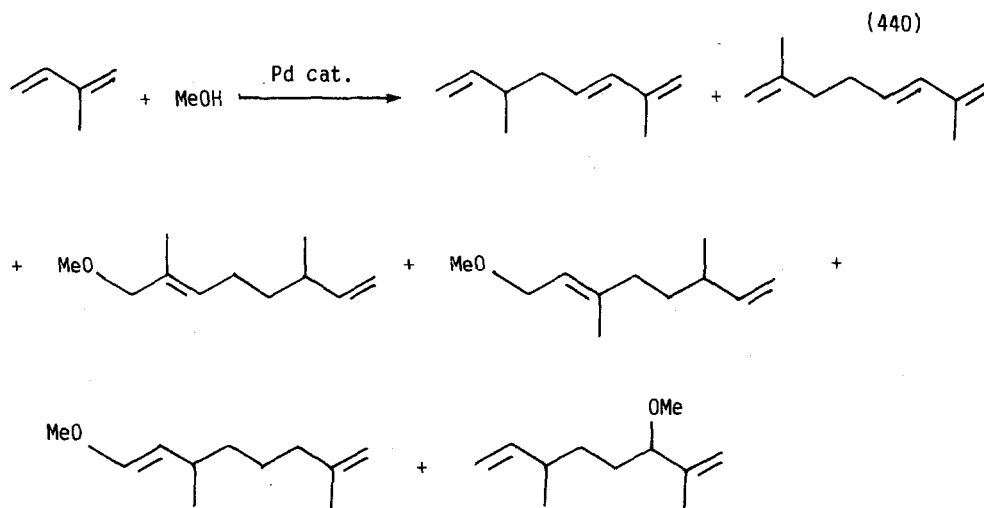
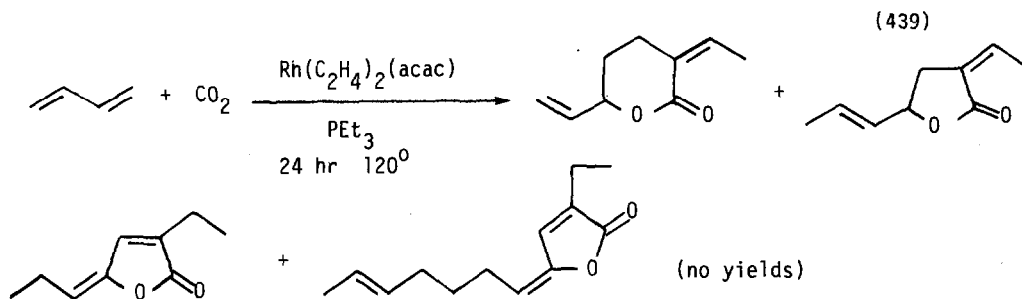

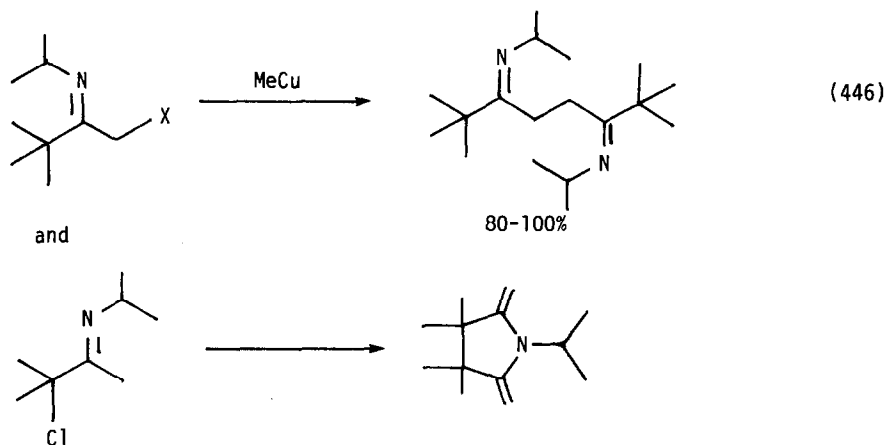
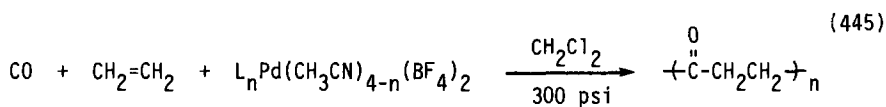
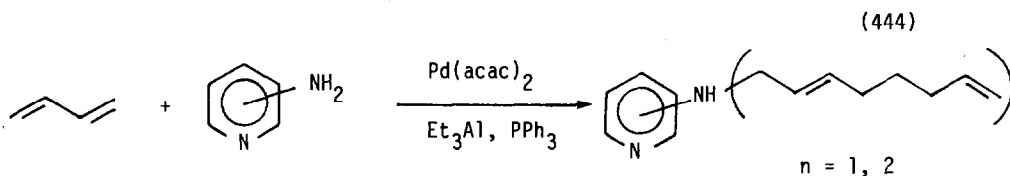
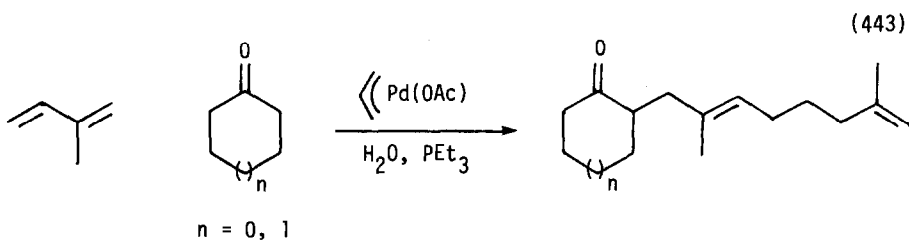

Cobalt catalyzed cyclotrimerization of alkynes continues to find extensive use in organic synthesis. Cobalt mediated 2+2+2 cycloadditions - a maturing synthetic strategy was the topic of a review (106 references) [524], as was a nonbiomimetic approach to the total synthesis of steroids - the transition metal catalyzed cyclization of alkenes and alkynes (10 references) [525]. The syntheses of cyclobutadienoids by thermal and cobalt-mediated cyclizations of diynes was the topic of a dissertation [526]. The full experimental details for the cobalt catalyzed cyclotrimerization of alkynes in the synthesis of polycyclic systems (equation 447), (equation 448) [527], (equation 449), (equation 450) [528] have appeared.



This general process has been applied to the synthesis of polysilated aromatics (equation 451) [529].

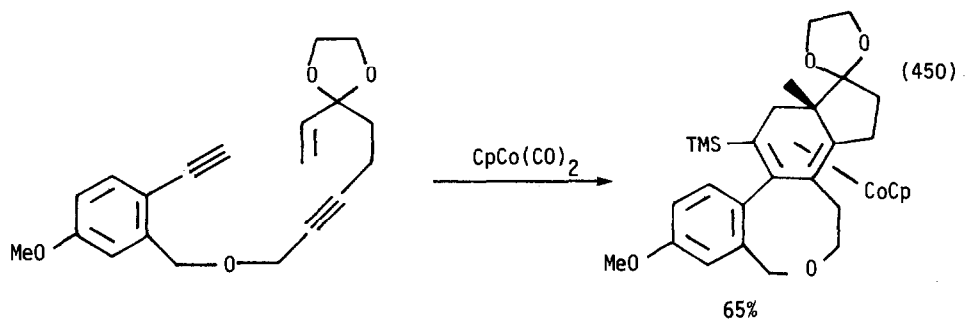
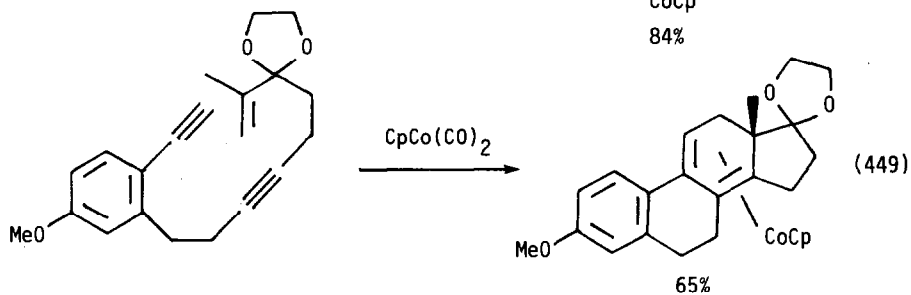
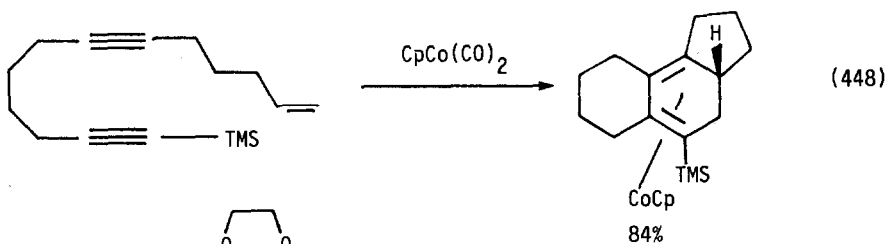
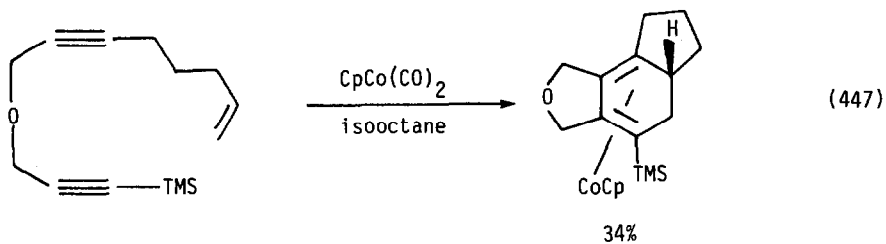

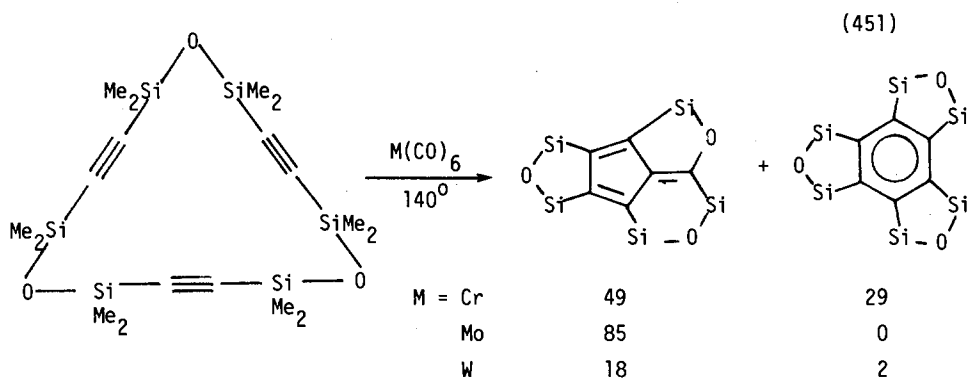

Titanium compounds cyclized internal alkynes to hexasubstituted benzenes in low yield (equation 452) [530]. Phenylacetylene was cyclized to 1,2,4-triphenylbenzene by nickel carbonyl phosphine catalysts [531]. Reduced nickel salts converted acetylene to benzene and/or cyclooctatetraene (equation 453) [532]. Bis-dimine complexes of nickel were selective catalysts for the cyclotetramerization of alkynes to cyclooctatetraenes (equation 454) [533]. Propiolic esters were cyclotrimerized to arenes by nickel-dimine complexes (equation 455) [534]; with sterically congested diimine ligands, production of cyclooctatetraenes became the major pathway (equation 456) [535].

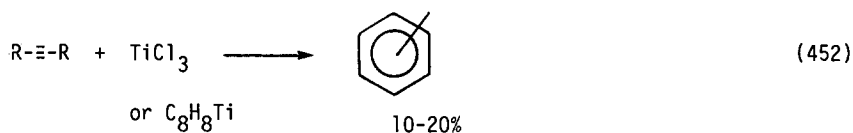

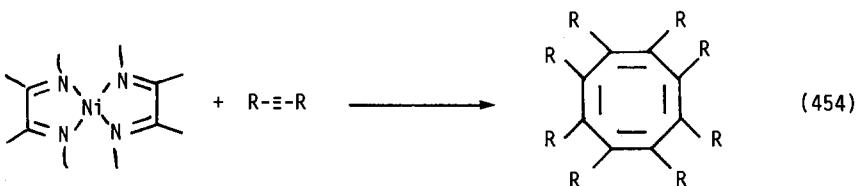
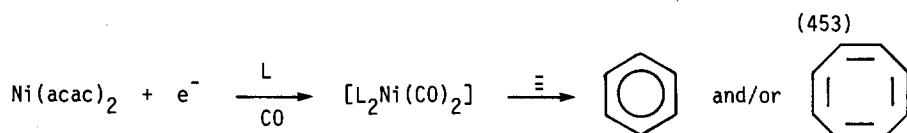

R = Ph, ptoI

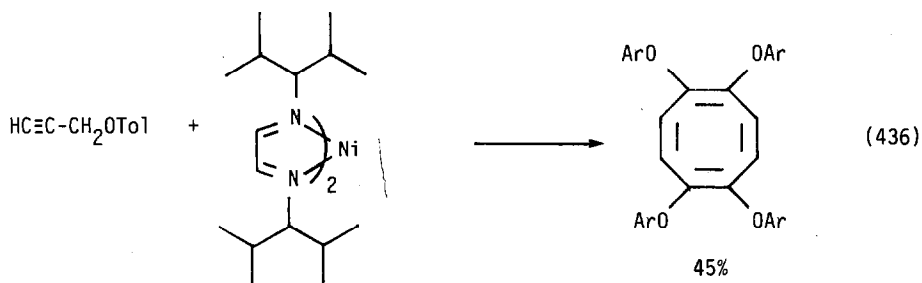
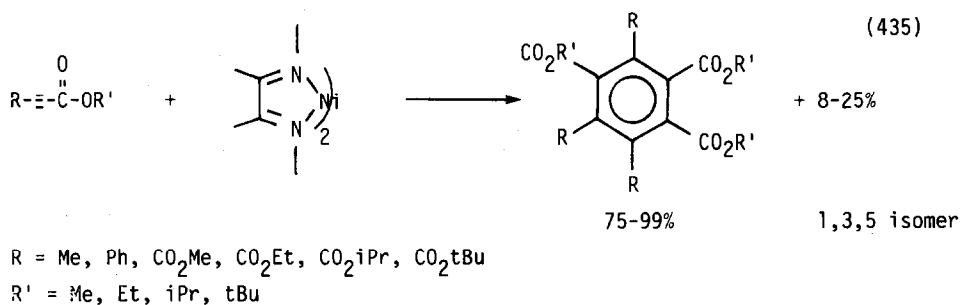

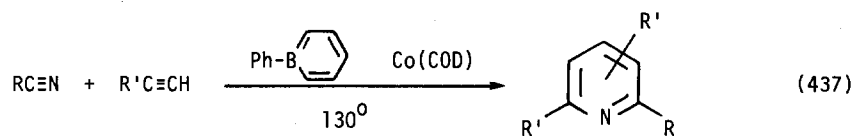

Nitriles cocyclotrimerized with alkynes to give pyridines in the presence of borabenzene cobalt catalysts (equation 457) [536]. The differences between cobalt(0) and cobalt(I) catalysts for the process have been examined [537]. Pyridoxine was synthesized by the cocyclotrimerization of a diyne with a nitrile (equation 458) [538]. Nitriles cyclotrimerized to triazines with  $\text{Fe}_2(\text{CO})_9$  as catalysts (equation 459) [539]. Aryl isocyanates cyclotrimerized to isocyanurates when photolyzed in the presence of a manganese catalyst (equation 460) [540].



R =  $\text{NH}_2$ , SMe, H,   
R' = H

(458)

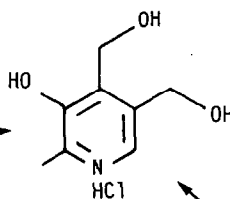
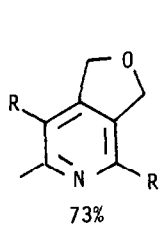
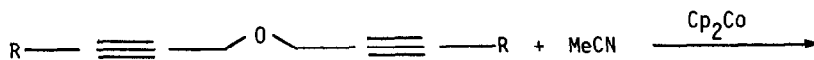

R = H, TMS

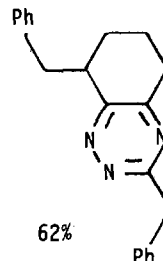
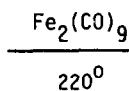
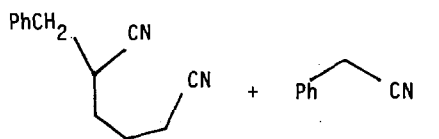
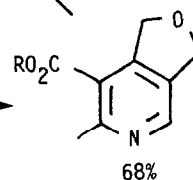
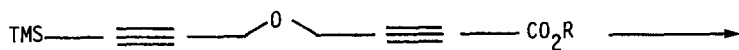

(459)

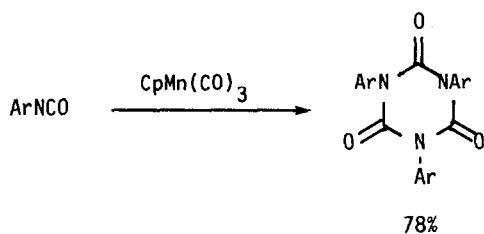
with  $\text{RC}\equiv\text{N}$ ; R = Bu, Ph,  $(\text{CH}_2)_4$  42-71%

(450)

## E. Rearrangements

## 1. Metathesis

A book (399 pages) on olefin metathesis has appeared [541]. Homogeneous metathesis of unsaturated hydrocarbons has been reviewed (78 references) [542]. Metathesis of 1-hexene over rhenium-oxide-alumina catalysts has been developed [543]. Metathesis of fatty esters has been reviewed (29 references) [544]. Metathesis of unsaturated esters has been carried out over  $\text{Re}_2\text{O}_7/\text{Al}_2\text{O}_3$  catalysts with tin cocatalysts [545]. Metathesis of methyl 10-undecenoate was catalyzed by tungsten(VI) chloride-tetraalkyltin systems [546]. Tungsten(VI) chloride or tungsten(VI) oxychloride in the presence of silanes was an efficient metathesis catalyst for unsaturated esters or nitriles, but not amides [547]. The metathesis catalyst  $\text{Re}_2\text{O}_7/\text{Al}_2\text{O}_3/\text{Me}_4\text{Sn}$  converted conjugated dienes into alkenes, conjugated trienes and conjugated tetraenes [548]. A similar catalyst was used to cometathesize 1,5-hexadiene with 2,3-dimethyl-2-butene [549]. Mixed ruthenium(II)-ruthenium(III) catalysts metathesized vinyl siloxanes (equation 461) [550]. Tungsten carbene complexes underwent metathesis with carbodiimides (equation 462) [551][552]. The diphenyl carbene-tungsten complex underwent a photochemical metathesis which involved a visible absorption and photoejection of carbon monoxide (equation 463) [553]. The same metathesis went much more slowly under thermal conditions.

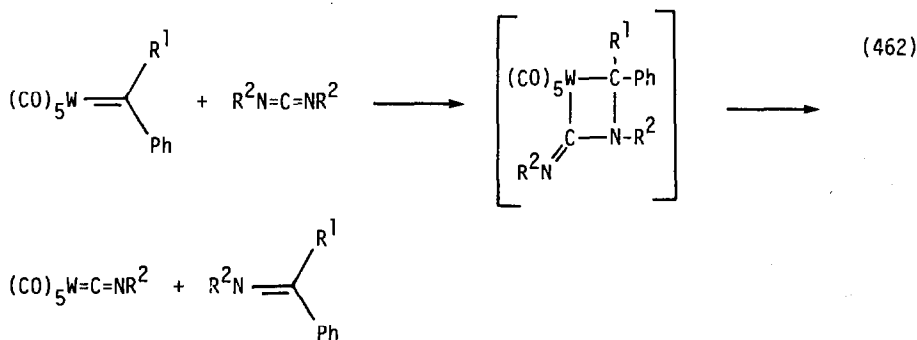
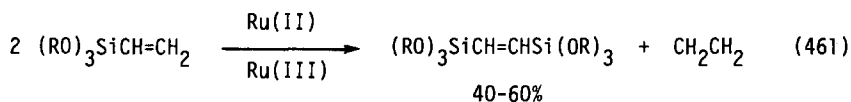

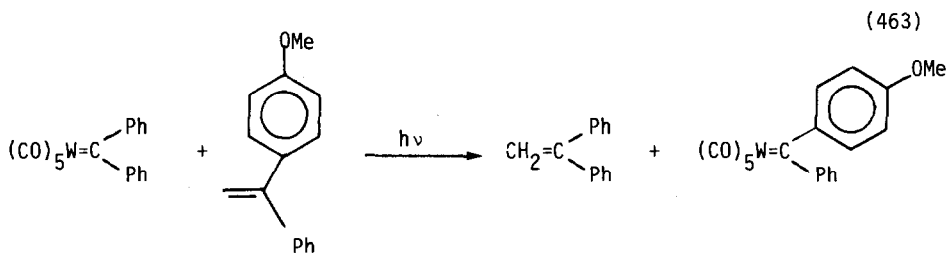

A paper dealing with the stereoselectivity of the ruthenium and osmium catalyzed metathesis ring opening polymerizations of norbornenes has appeared [554]. In the tungsten catalyzed ring-opening polymerization of norbornene with olefins, two kinetically distinct propagating metallacyclobutanes were proposed. Terminal olefins were thought to act as chain transfer agents [555]. Norbornenes containing pendent amino groups underwent ring opening polymerization with tungsten metathesis catalysts (equation 464) [556]. Tungsten-carbyne complexes polymerized alkynes (equation 465) and cyclic olefins [557], and catalyzed acetylene metathesis (equation 466) [558].

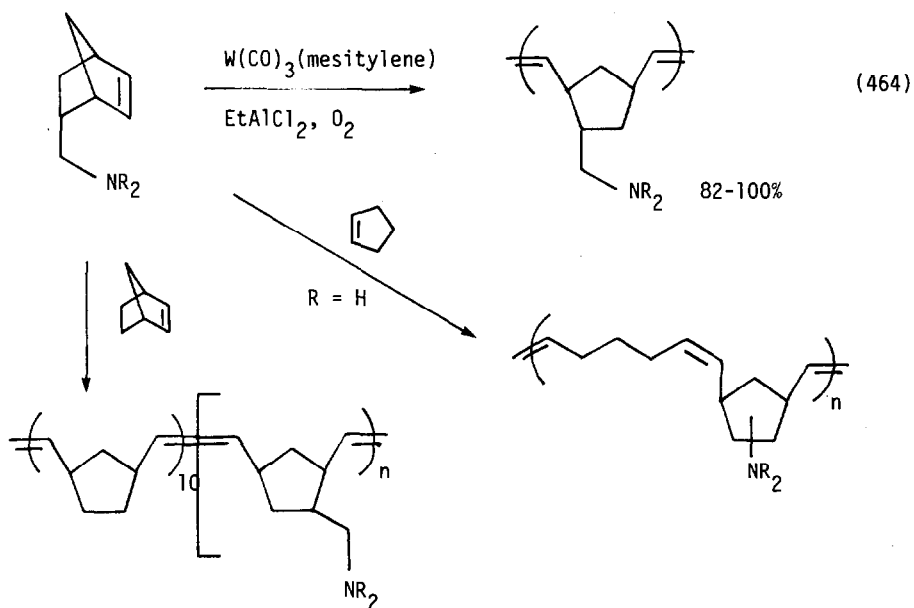

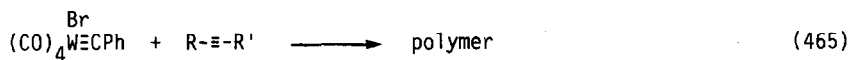

alkyne = Ph-C≡, Me-C≡, tBu-C≡, nBu-C≡, Me-C≡-Et, Me-C≡-Me, H-C≡-H, H-C≡-(CH<sub>2</sub>)<sub>2</sub>Cl,  
H-C≡-(CH<sub>2</sub>)<sub>3</sub>CO<sub>2</sub>Me, (CN)H-C≡-CH<sub>2</sub>OMe, H-C≡-CO<sub>2</sub>Me

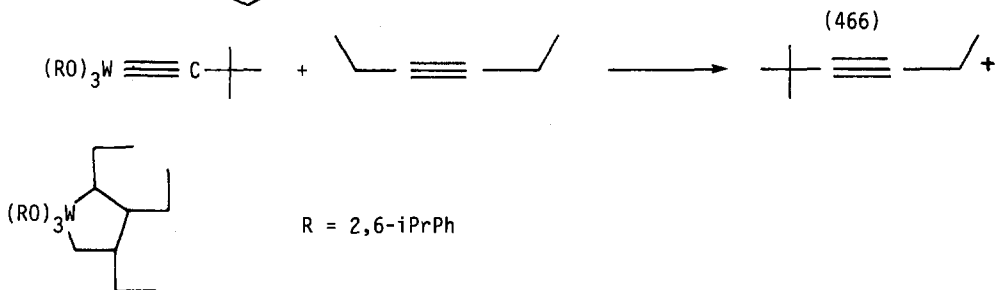
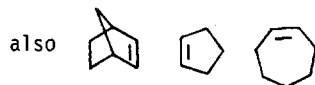

## 2. Olefin Isomerization

The mechanism of 1-butene isomerization by zeolite A has been studied [559]. The highly electrophilic palladium(II) species  $(\text{MeCN})_4\text{Pd}^{2+}(\text{BF}_4)_2^-$  catalyzed olefin isomerizations via  $\eta^3$ -allyl palladium species [560]. Olefins were readily rearranged by  $\text{Cp}_2\text{TiCl}_2/\text{LiAlH}_4$  catalysts [561]. Photolysis of cyclooctadiene copper(I) complexes led to olefin isomerization (equation 467) [562].

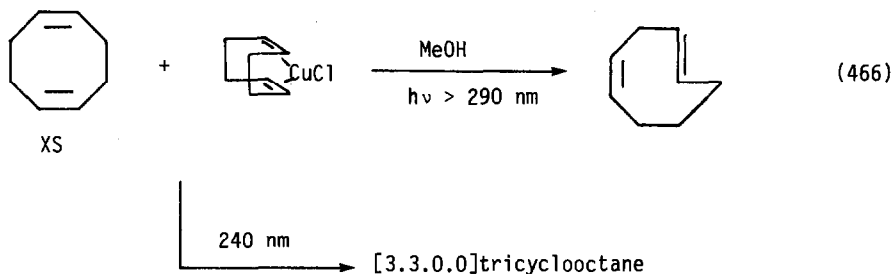

## 3. Rearrangements of Allylic and Propargylic Oxygen and Nitrogen Compounds

Palladium(II) complexes catalyzed the rearrangement of allylic esters with high stereoselectivity for the E-isomer regardless of stereochemistry of the starting material (equation 468) [563], (equation 469) [564]. Allylic carbamates were more reactive than acetates, which were more reactive than carbonates [564]. Palladium(II) complexes also catalyzed the rearrangement of propargyl phosphorous compounds (equation 470) [565] and allyl sulfinates (equation 471) [566].

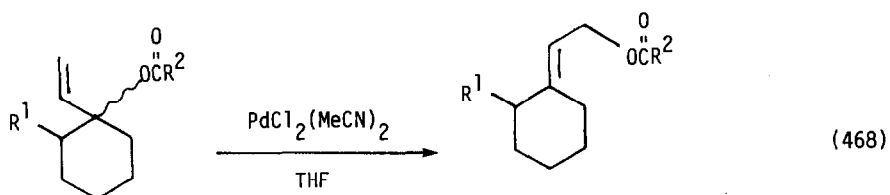

$R^1 = \text{Me, Et, iPr, Ph}$

$R^2 = \text{Me, Ph}$

80-90%

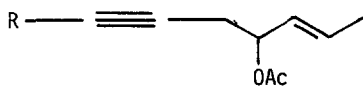
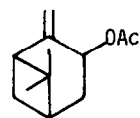
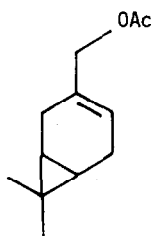
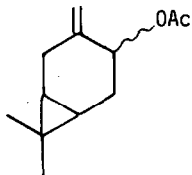
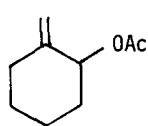
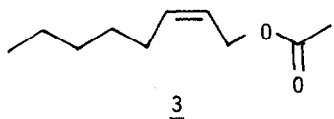
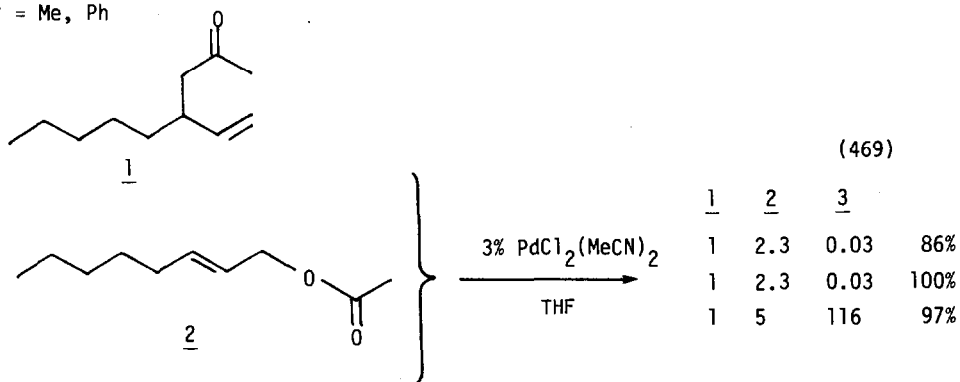

don't rearrange



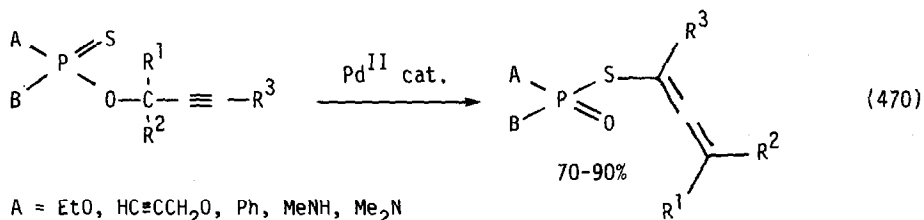

A = EtO, HC≡CCH<sub>2</sub>O, Ph, MeNH, Me<sub>2</sub>N

B = EtO Ph; R<sup>1</sup> = H, Me; R<sup>2</sup> = H, Me; R<sup>3</sup> = H, Me

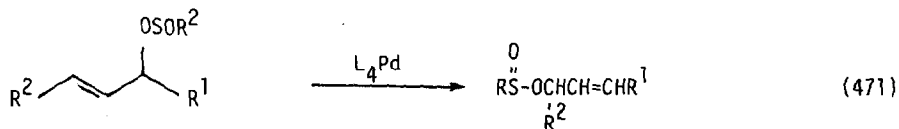

Palladium(0) complexes catalyzed the conversion of allyl carbonates to ketones (equation 472) [567], (equation 473) [568]. Molybdenum(0) and nickel(0) complexes catalyzed a similar rearrangement (equation 474) [569]. Ruthenium(III) acetylacetonate catalyzed the rearrangement of allyl alcohols to aldehydes (equation 475) [570]. Zirconium oxide on alumina catalyzed the same rearrangement at high temperature (280<sup>o</sup>) [571]. Palladium(0) complexes catalyzed the rearrangement of allyl epoxides to α,β-unsaturated aldehydes (equation 476) [572].

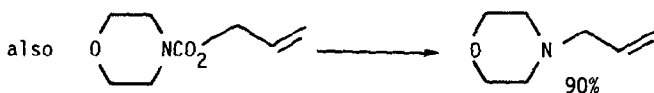
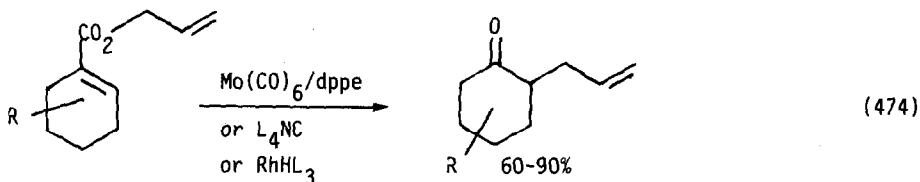
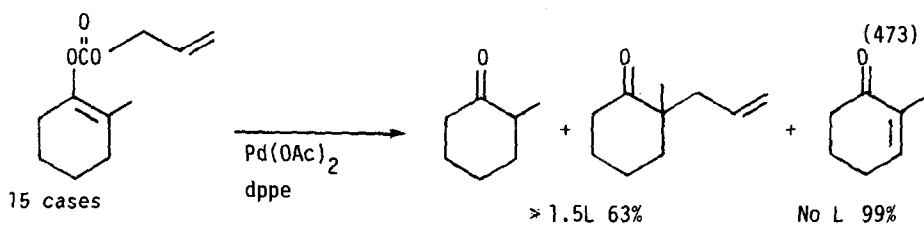
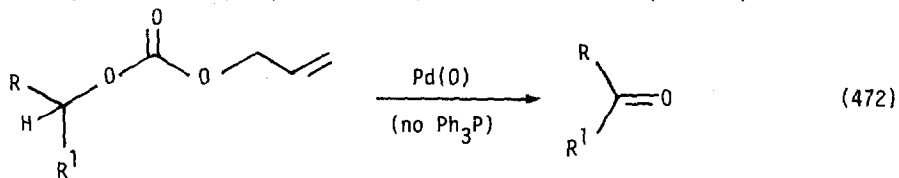

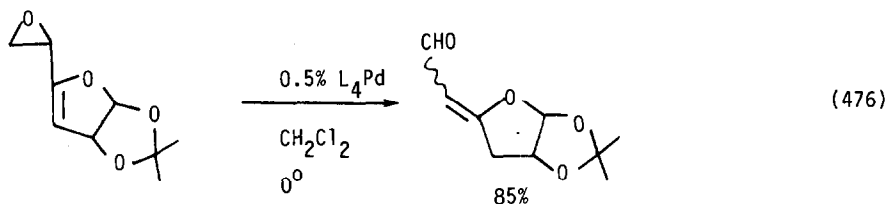
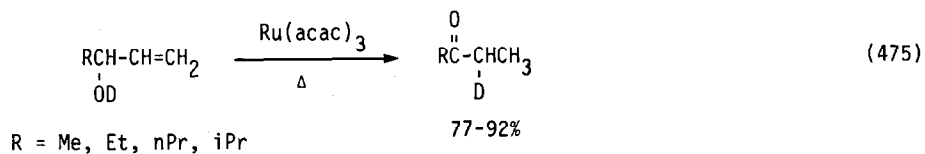

Allyl amines were rearranged to enamines by Wilkinson's catalyst (equation 477) [573]. When that process was blocked by substitution, olefin isomerization resulted (equation 478) [574]. Chiral rhodium(I) phosphine complexes catalyzed the isomerization of allylamines to enamines with greater than 96% ee [575] (equation 479) [576]. Propargyl amines were isomerized to dieneamines by ruthenium(II) hydride catalysts (equation 480) [577]. The heterocyclic allyl amine in equation 481 underwent rearrangement when treated with rhodium(I) catalysts [578].

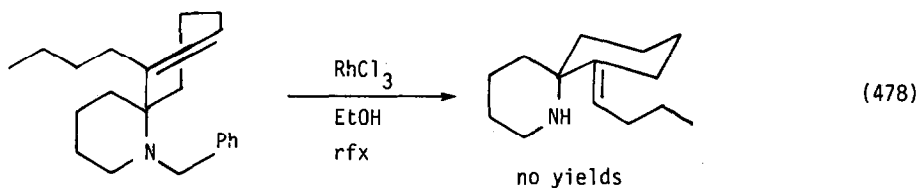
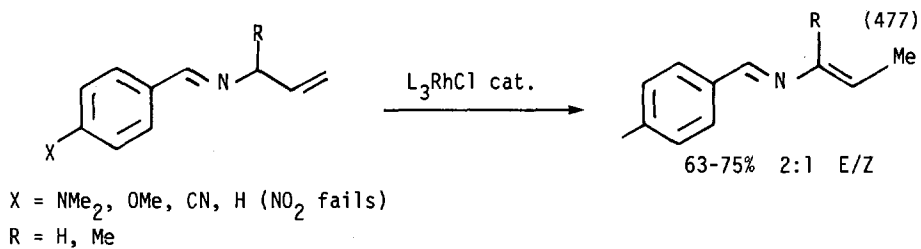

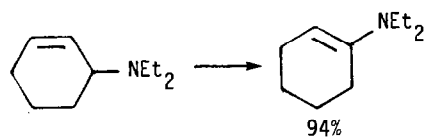
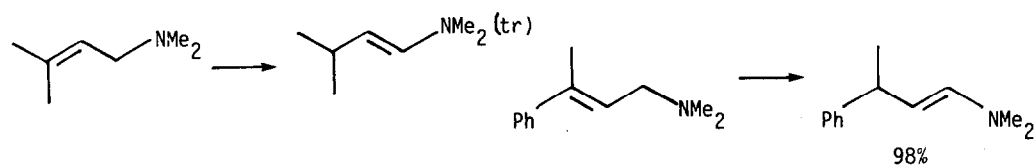
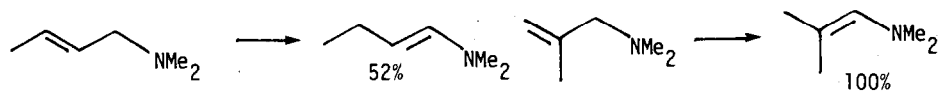
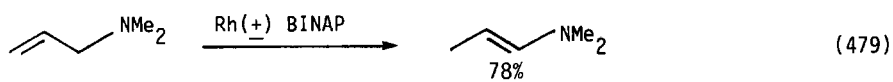

with chiral Rh complexes and prochiral allylamines up to 97% ee

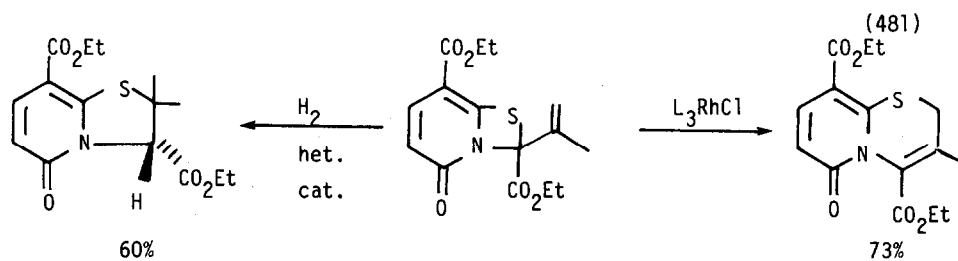
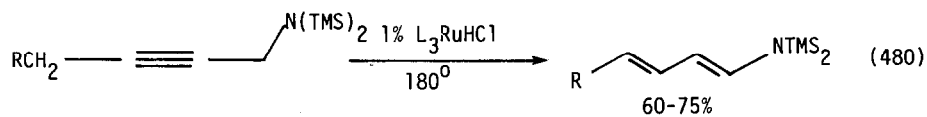

## 4. Skeletal Rearrangements

Carbon skeleton rearrangement of aldoose by molybdate was the subject of a review (16 references) [579]. The mechanism of dehydrocyclization and skeletal isomerization reactions of hydrocarbons in the presence of metal catalysts has been reviewed (170 references) [580], and studied in detail [581]. Palladium(II) complexes greatly accelerated the photochemical rearrangement of quadricyclane to norbornadiene [582]. The kinetics of this isomerization has been studied [583]. Iron(III) catalyzed the ring opening of a cubane-like structure (equation 482) [584].

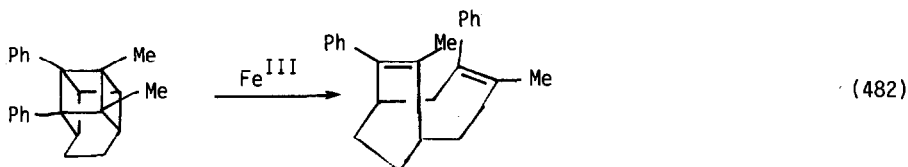

Mercury(II) and palladium(II) catalyzed [3,3] sigmatropic rearrangements have been reviewed [585]. A dissertation dealing with chain topology of palladium dichloride catalyzed Cope rearrangement of 1,5-hexadienes has appeared [586]. Palladium(0) complexes catalyzed the rearrangement of diene substituted cyclopropane dicarboxylate (equation 483) [587]. Nickel(II) chloride catalyzed the rearrangement shown in equation 484 [588].

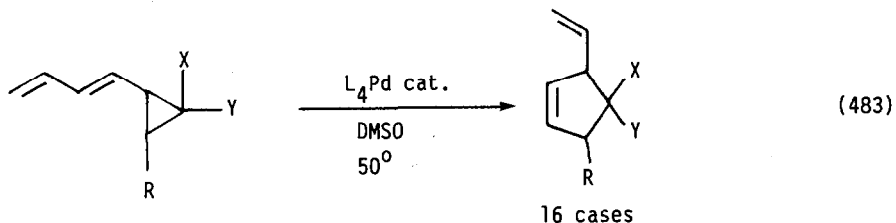

X = CO<sub>2</sub>Me, SO<sub>2</sub>Ph, COMe

Y = CO<sub>2</sub>Me

R = H, Me

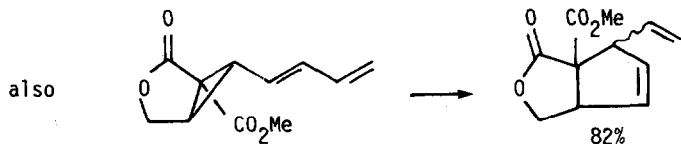

## 5. Miscellaneous Rearrangements

Palladium(II) acetate catalyzed the aryl group exchange between triphenyl phosphine and tri-*p*-tolyl phosphine via a radical process [589]. Photolysis of an  $n^3$ -farnesyl palladium complex gave a mixture of squalene isomers [590].

## III. Functional Group Preparation

## A. Halides

Stereo- and regioselective halogenation and pseudohalogenation via organo-metallic compounds has been reviewed (65 references) [591]. Propargyl sulfonates were halogenated by copper(II) halides to give haloallenes (equation 484) [592]. Carboxylic acids were  $\alpha$ -iodinated by iodine and copper(II) acetate (equation 485) [593]. Propargyl alcohols were converted to allenic halides with clean antistereoselectivity by copper(I) halides (equation 486) [594].

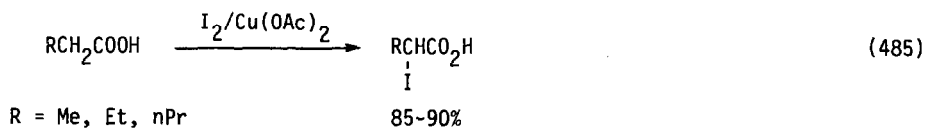
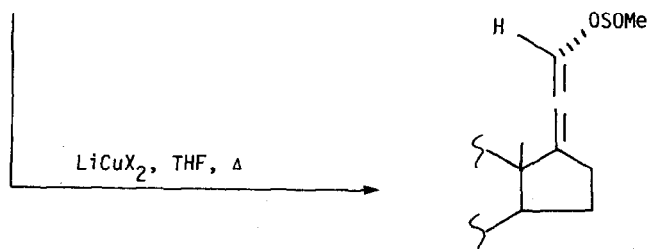
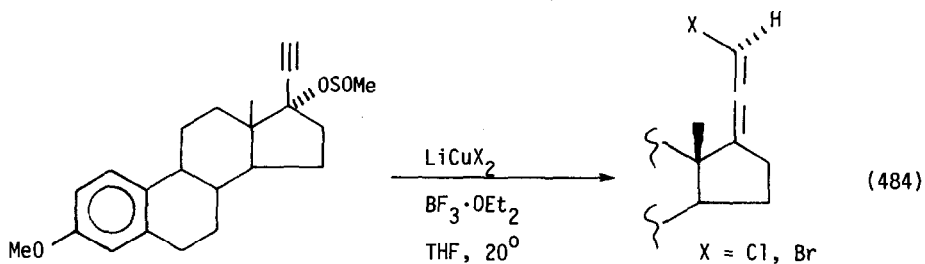

R = Me, Et, nPr

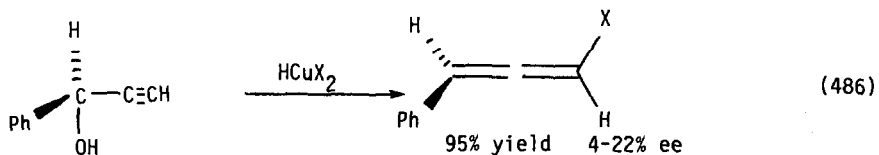

An unactivated steroidal methyl group was iodinated via a ligand directed palladation (equation 487) [595]. Norbornene was oxychlorinated by palladium(II) chloride sodium nitrite (equation 488) [596]. Cyclohexene was dibrominated by a mixture of nickel(II) oxygen and molybdenum(VI) dibromide complexes (equation 489) [597]. Olefins were chlorinated by manganese(III) acetate/copper(II) chloride (equation 490) [598]. Epoxides were opened to trans bromohydrins by nickel(II) bromides (equation 491) [599].

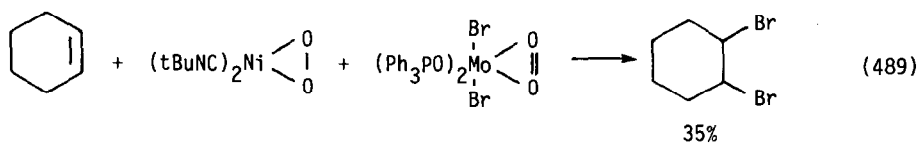
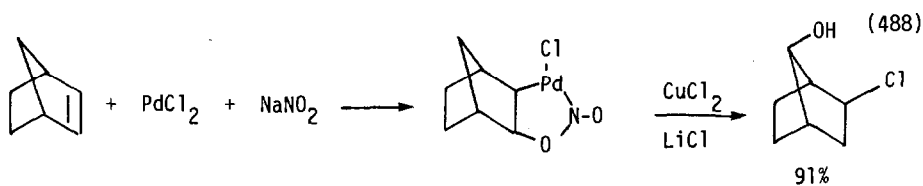
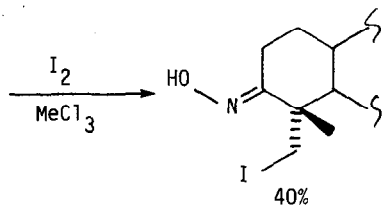
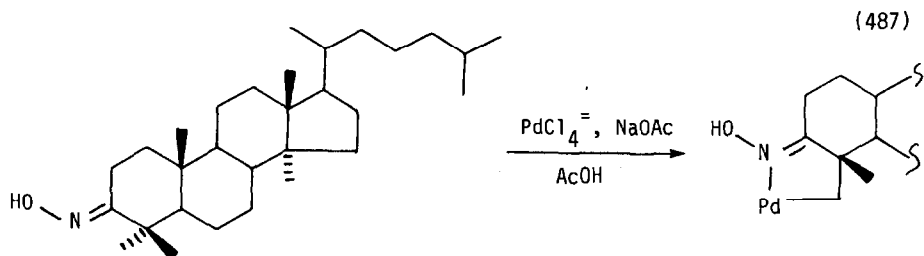

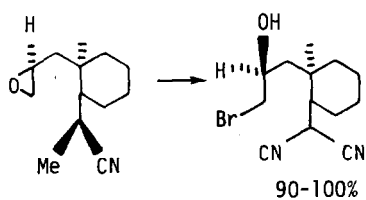
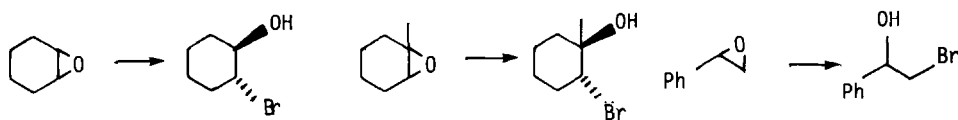
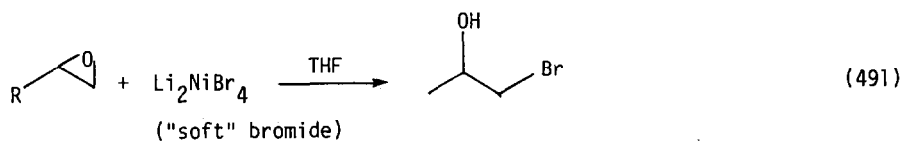
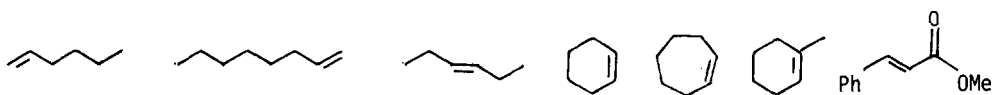
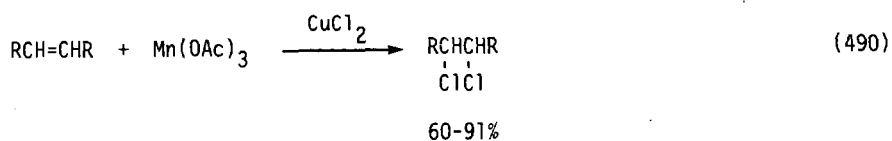

## B. Amides, Nitriles

Ketals were converted to cyanohydrin ethers by treatment with isocyanides and titanium(IV) chloride (equation 492) [600]. Iodocarbonates were converted to the corresponding acid cyanide by copper(I) cyanide (equation 493) [601]. Nickel(0) complexes catalyzed the addition of HCN to alkynes (equation 494) [602] and dienes (equation 495) [603]. The stereochemistry of addition was cleanly *cis*. With acyclic dienes linear products were favored by Lewis acids (equation 496) [604].

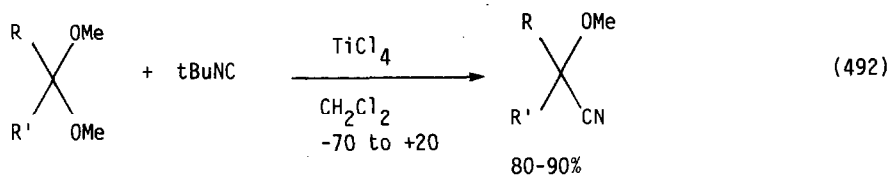

R, R' = H, Ph, nPr, (CH<sub>2</sub>)<sub>4</sub>, (CH<sub>2</sub>)<sub>5</sub>

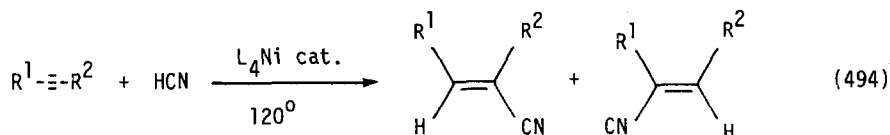
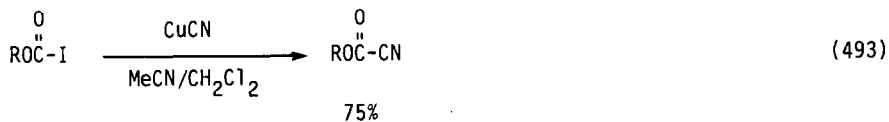

R<sup>1</sup> = Ph, CO<sub>2</sub>Me, tBu, Pr, Ph

R<sup>2</sup> = Ph, CO<sub>2</sub>Me, Me, H (B formed when R<sup>2</sup> = H)

20-96%

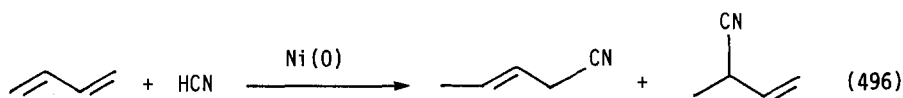
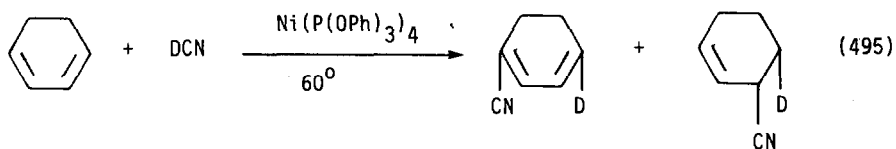

(Lewis acid favors)

Palladium(0) complexes catalyzed the formation of N-allylphthalimides from allylic acetates, ethers, and carbamates (equation 497) [605]. Ruthenium tetroxide oxidized morpholines to amides in low yield (equation 498) [606]. Gabuline was synthesized in a process involving amination of a cyclohexadienyliron complex by a carbamate (equation 499) [607].  $\alpha$  Azido amides were converted to enamides by sodium rhenate (equation 500) [608].



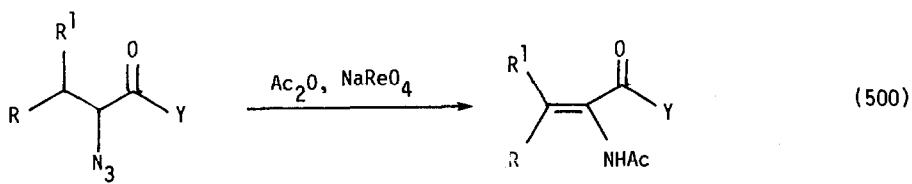
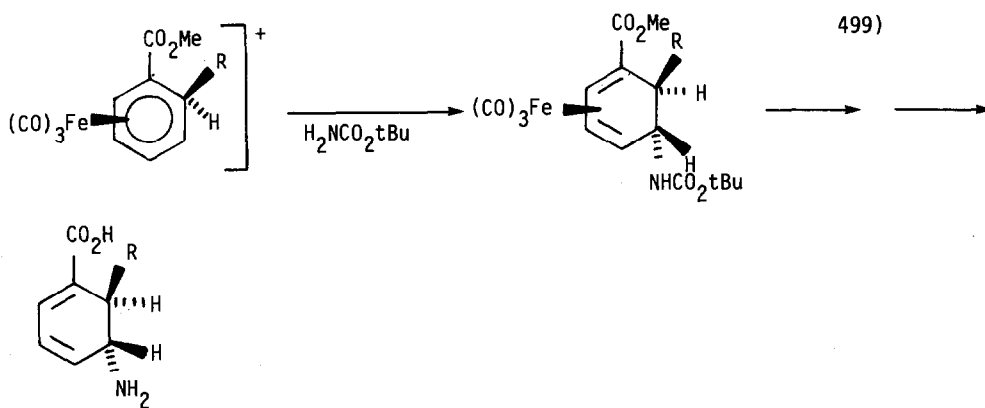
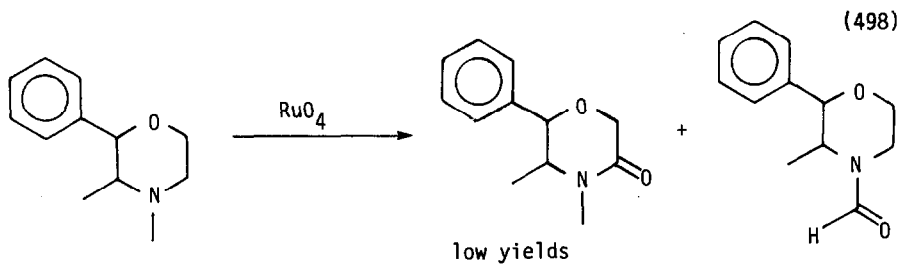
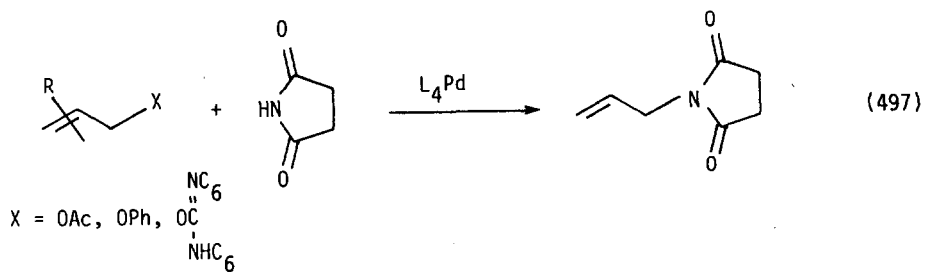

R = nPr, Me

R<sup>1</sup> = H, Me

Y = NMe<sub>2</sub>

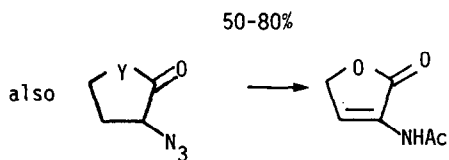

## C. Amines, Alcohols

The mechanism of the amination of olefins has been studied in detail [609]. The stereochemistry of this process was shown to be stereospecifically trans, by isolating the unstable  $\sigma$ -alkylpalladium(II) complex and characterizing it by nmr spectroscopy (equation 501) [610]. Allylic amines were synthesized by the palladium catalyzed aminoalkylation of 1,2-dienes (equation 502) [611].

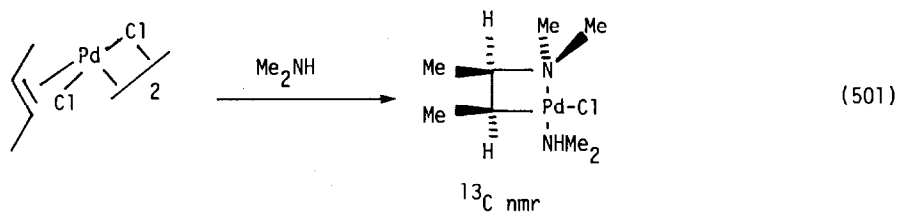

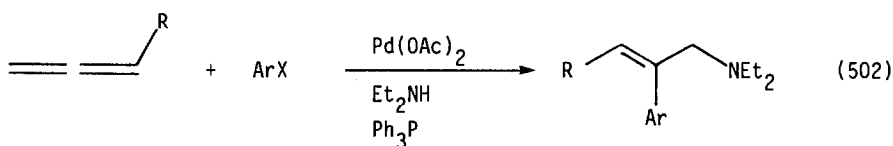

(also done for cis olefin)

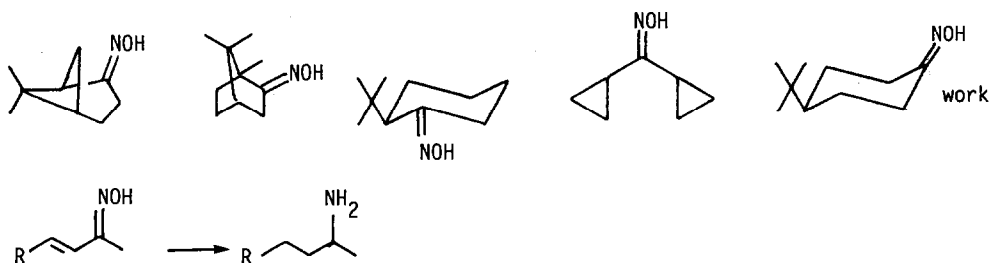
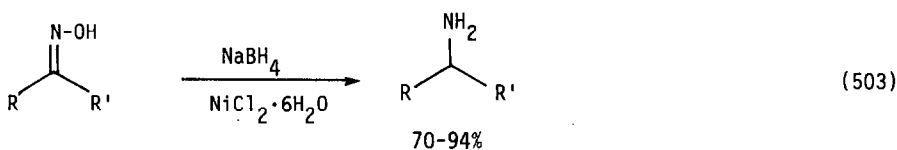

Sodium borohydride reduced oximes to amines in the presence of nickel(II) chloride (equation 503) [612]. O-Alkylaldoximes were hydrolyzed to alcohols and ruthenium imine complexes by  $[(\text{H}_3\text{N})_5\text{Ru}(\text{H}_2)^{2+}]$  salts [613]. Formamide was reduced to methylamine by hydrogen and Group(VI) transition metals [614]. Aldehydes were reductively coupled to diamines by vanadium(IV) amide complexes (equation 504) [615].

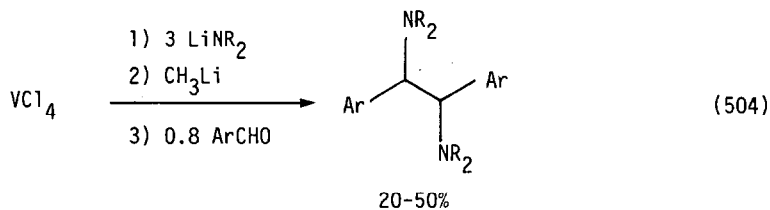





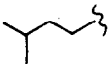

Ar = Ph, pMeOPh, , 1-Naphth  
 R = Et, (CH<sub>2</sub>)<sub>5</sub>

Nitroaromatics were reduced to amines by silica-supported poly(vinylpyrrolidone)-palladium complexes and hydrogen [616], by sodium borohydride-copper(I) chloride [617], by *trans* dihalobis(pyridine)palladium(II) and hydrogen [618], and by ammonium formate/palladium on carbon (equation 505) [619]. Aliphatic and aromatic N-oxides were reduced to amines by titanium(III) chloride [620], while the same reagent reduced N-nitrosamines to hydrazines (equation 506) [621]. Nitrobenzene was reduced to aniline by Rh<sub>6</sub>(CO)<sub>16</sub>, carbon monoxide, and water (water gas shift conditions) [622].



R = nPr, 31%; nBu, 49%; , 82%; EtO<sub>2</sub>CCH<sub>2</sub>-, 64%; HO<sub>2</sub>C-, 98%;  
 MeO<sub>2</sub>C(CH<sub>2</sub>)<sub>3</sub>-, 81%; MeO<sub>2</sub>CH<sub>2</sub>OCH<sub>2</sub>CH-, 75%  
 CH<sub>3</sub>

also ArNO<sub>2</sub> with F, MeO, Me, NH<sub>2</sub>, CN, PhCO || Note ArI → ArH

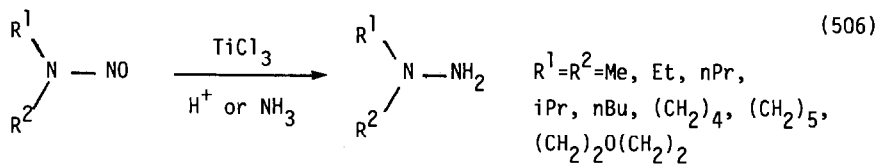

Aromatic amines were alkylated by alcohols in the presence of ruthenium(II) chloride (equation 507) [623], and underwent alkyl group transfers in the presence of platinum(II) chloride and stannous chloride (equation 508) [624]. Phenyl isocyanate and benzaldehyde condensed in the presence of nickel(0) complexes to produce imines (equation 509) [625]. Enamines were produced from ketones by reaction with titanium(IV) morpholine complexes (equation 510) [626].

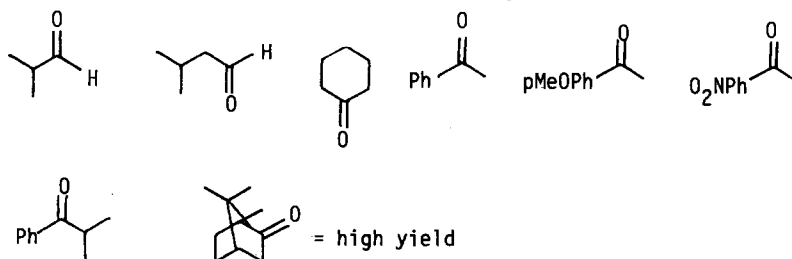
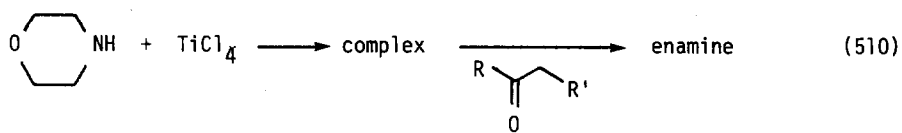
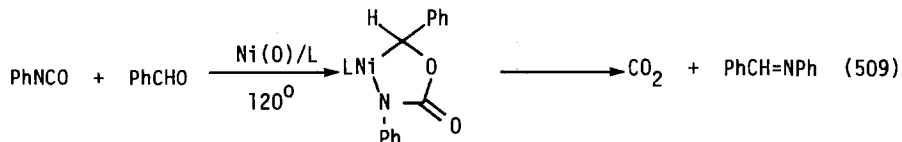
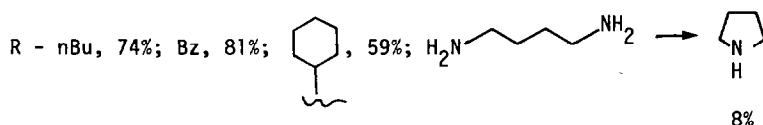
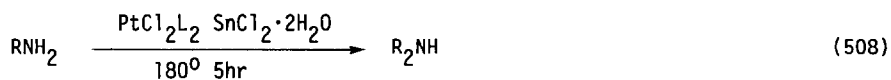
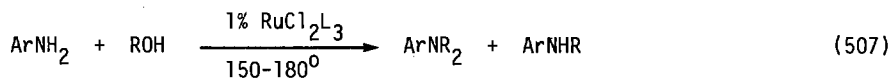

Olefins were hydrozirconated, then hydrolyzed to give terminal alcohols in good yields [627][628]. The reagent resulting from reaction of titanium(III) chloride with sodium borohydride and 18-Crown-6 "hydrotitanated" olefins to ultimately produce alcohols upon hydrolysis (equation 511) [629]. Cyclooctene was converted to the allylic alcohol by rhodium(I) catalyzed oxidation (equation 512) [630]. Norbornadiene was oxidized to a tricyclic diol by hydrogen peroxide/ $\text{MoO}_3$  (equation 513) [631]. Styrenes were converted to benzyl alcohols by reaction with borohydride and oxygen in the presence of cobalt/tetraphenylporphyrin complexes (equation 514) [632]. Manganese porphyrins performed similar chemistry [633]. Allyl alcohols were produced by the nickel(II) or palladium(II) catalyzed reaction of silylmethyl Grignard reagents with vinyl halides followed by oxidation with MCPBA (equation 515) [634]. Ortho palladated azobenzenes were oxidized by MCPBA (equation 516) [635].

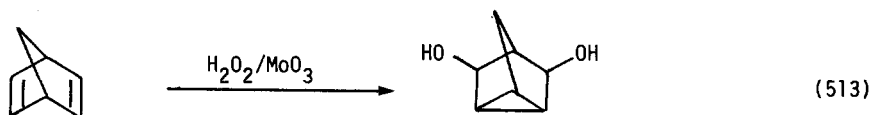
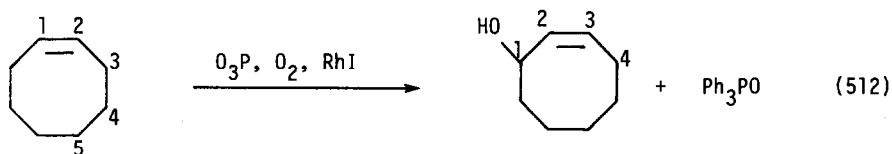
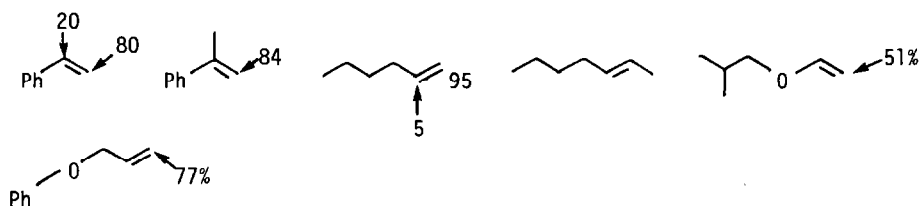
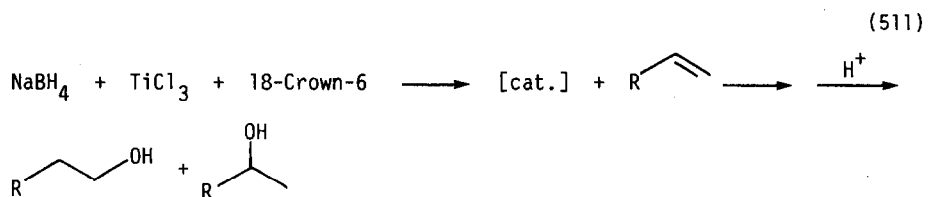

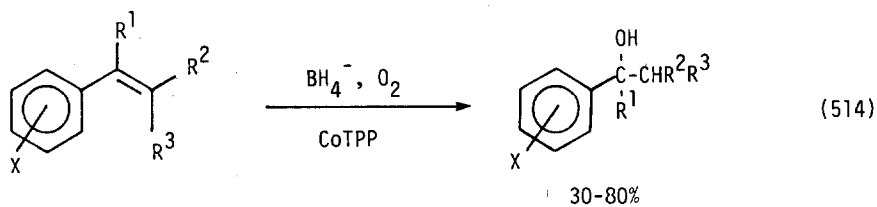

X = H, 4Cl, 4Me, 2OMe, 4OMe, 4Br, 4NO<sub>2</sub>

R<sup>1</sup> = H, Me, indene, Ph

R<sup>2</sup> = H, Me, CH<sub>2</sub>OH, CH=CH<sub>2</sub>, CH<sub>2</sub>CH=CH<sub>2</sub>, (CH<sub>2</sub>)<sub>2</sub>CH=CH<sub>2</sub>

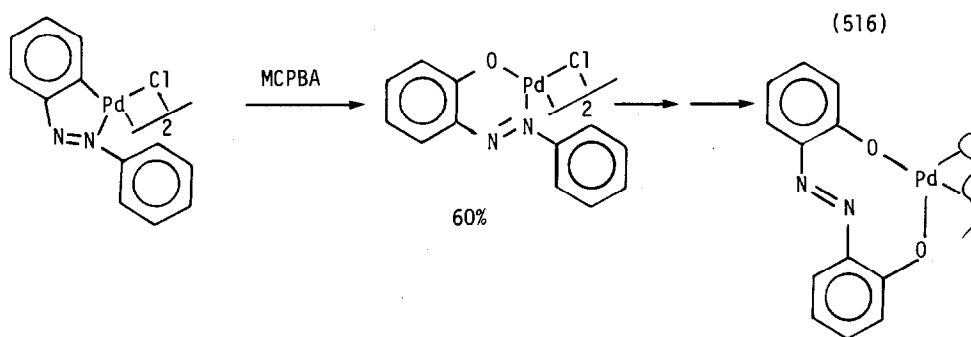
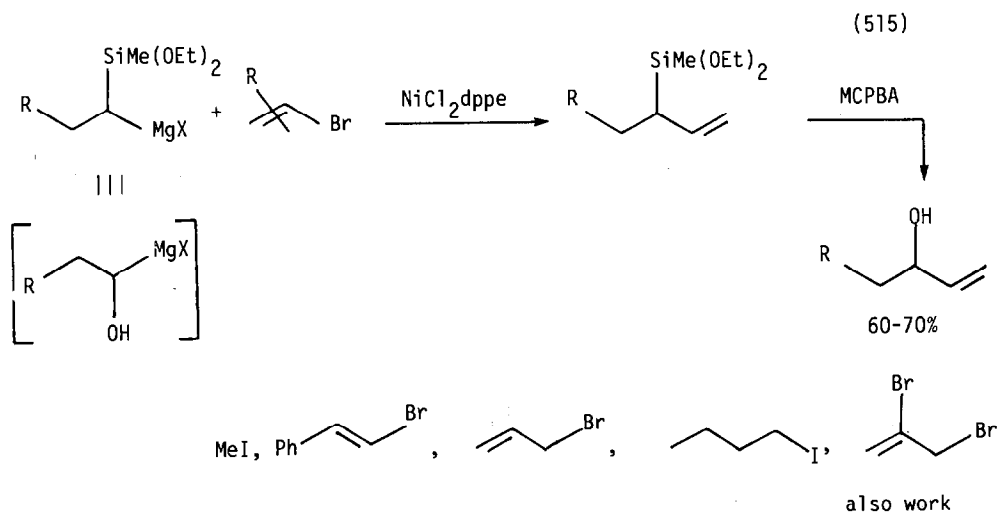

Cobalt(I) hydrides effected a photolytic transfer hydrogenation (equation 517) [636]. A large number of other metal complexes were efficient transfer hydrogenation catalysts (equation 518) [637], including  $\text{Ir}(\text{COD})(\text{PPh}_3)_2^+$  [638]. Cobalt TPP catalyzed the  $\text{BH}_4^-$  reduction of ketones under irradiation [639]. Chiral rhodium complexes catalyzed the asymmetric reduction of aryl ketones by silanes (equation 519) [640].

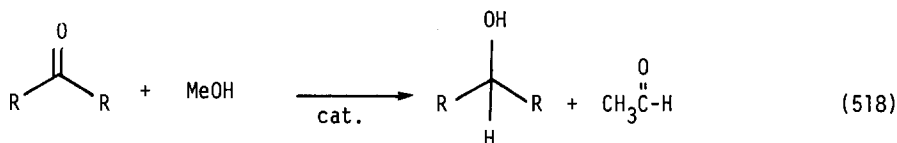
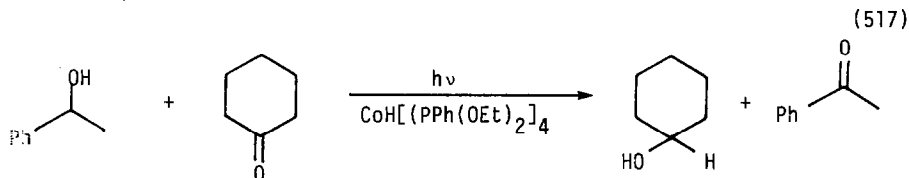

cat. =  $(\text{Me}_5\text{C}_5\text{Rh})_2\text{Cl}_4$ ,  $(\text{Me}_5\text{C}_5\text{Rh})_2(\text{OH})_3\text{Cl}$ ,  $\text{OsH}(\text{Br})(\text{CO})\text{L}_3$ ,  $(\text{C}_5\text{Me}_5\text{Ir})_2\text{Cl}_4$

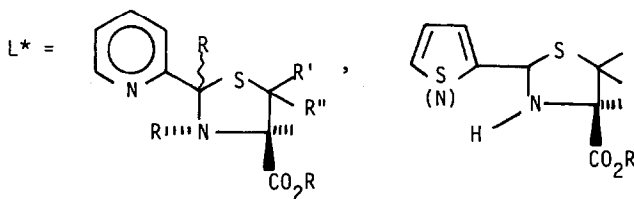
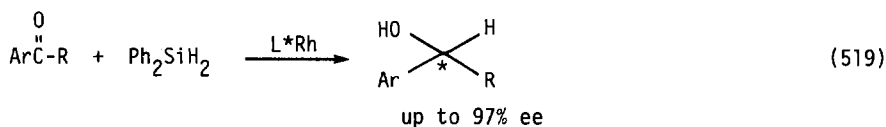

Osmium tetroxide oxidized chiral sulfoximines to chiral diols with (assumed) 100% ee (equation 520) [641]. Indoles were oxidized by  $\text{MoO}_5\cdot\text{HMPA}$  (equation 521) [642]. Electrochemical reduction of hindered aryl ketones in DMF in the presence of chromium(III) chloride gave  $\alpha$ -glycols without polymerization (equation 522) [643].

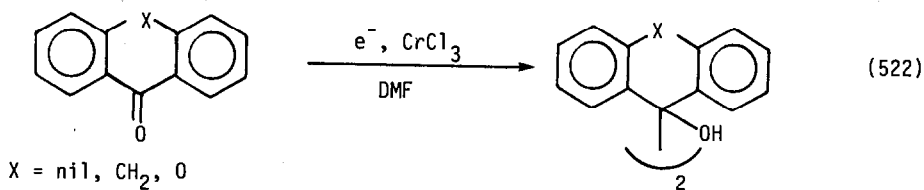
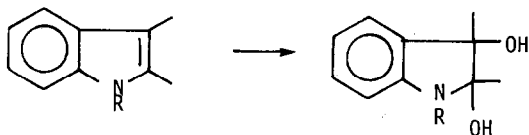
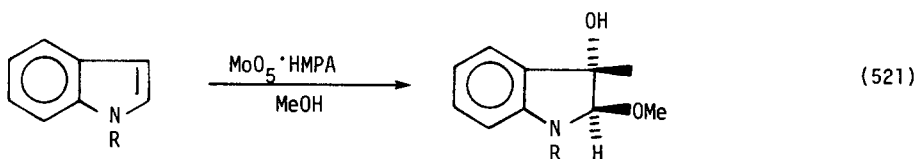
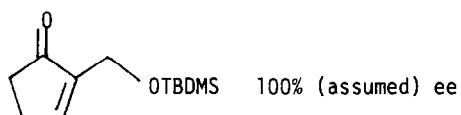
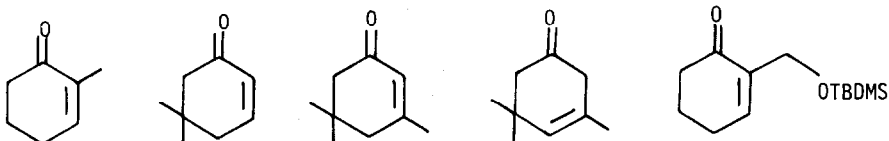
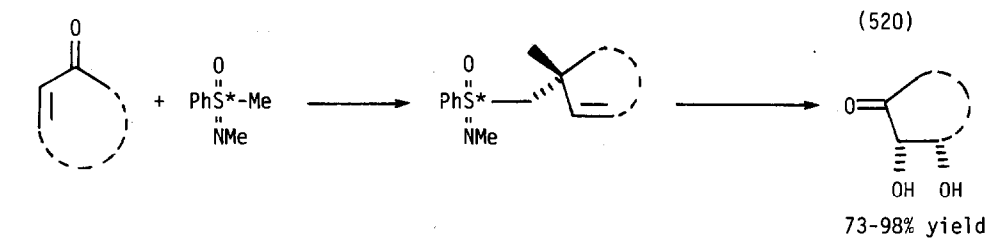



## D. Ethers, Esters, Acids

Palladium(II) salts catalyzed the alkoxy-palladation of dienes to give ethers. The regiochemistry of alkoxylation (equation 523) [644], (equation 524) [645] depended on the specific reaction conditions.

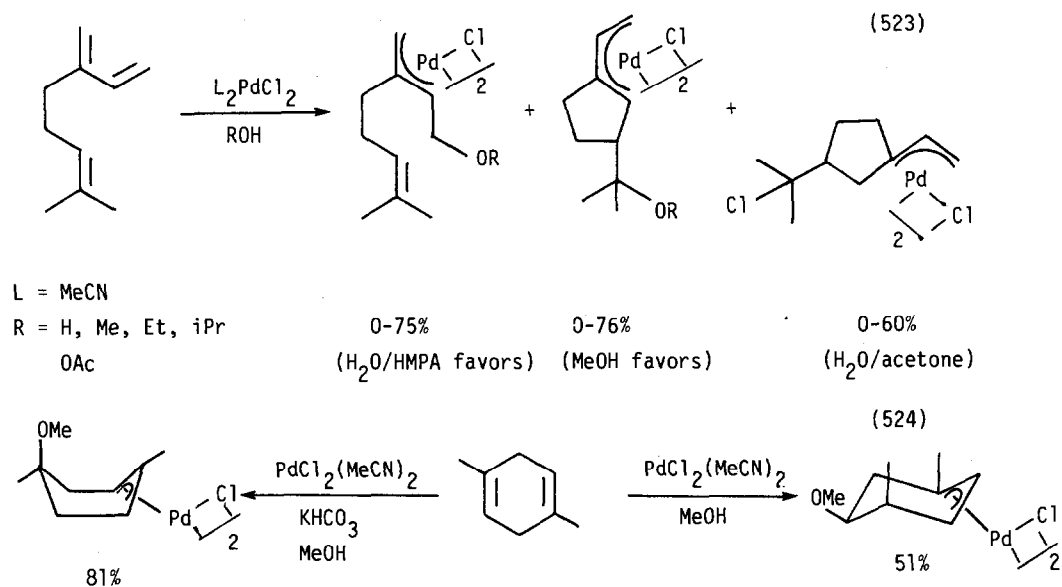

Palladium-catalyzed oxidations in selective organic syntheses has been reviewed (20 references) [646]. The full details on the palladium-catalyzed 1,4-acetoxy-chlorination or diacetoxylation of 1,3-dienes has appeared (equation 525) [647]. This process was utilized to make dienic amines (equation 526) [648], and functionally differentiated 1,4-diester-2-enes (equation 527) [649]. Diene phosphonates and sulfinates were also prepared by this procedure (equation 528) [650].

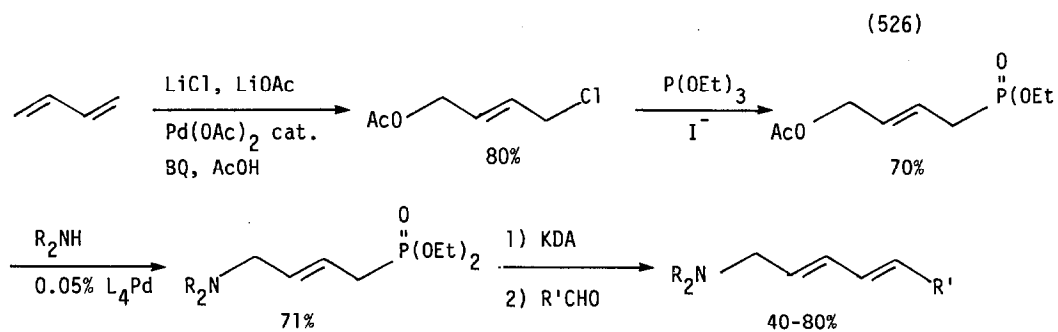
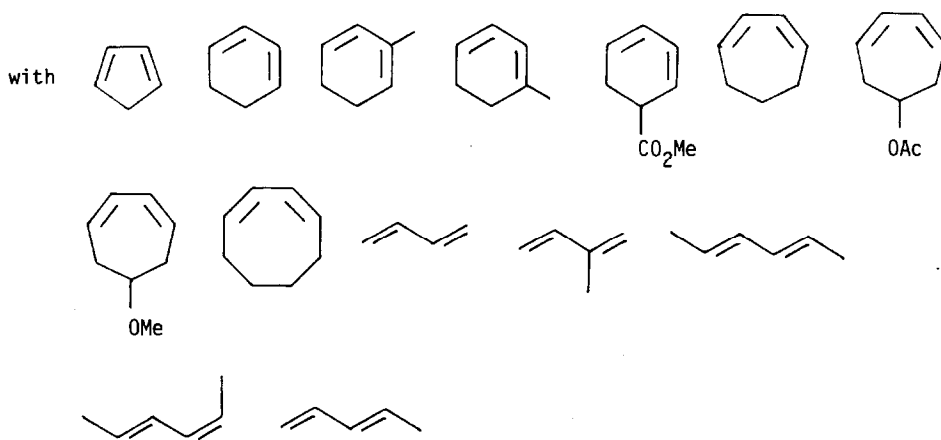
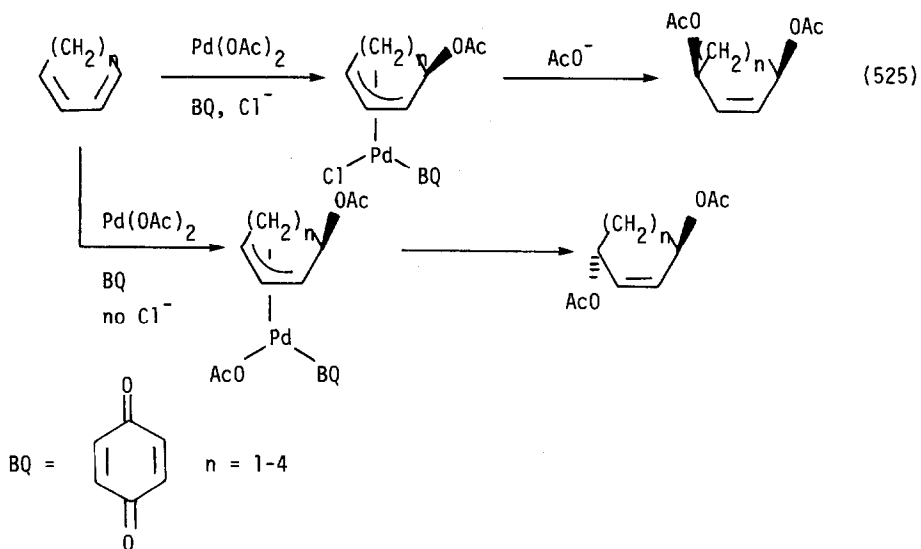

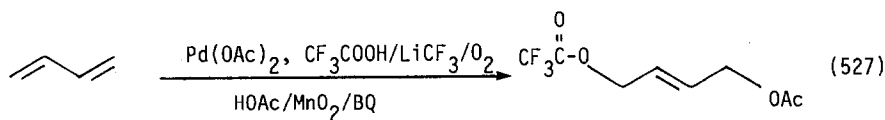

6 cases

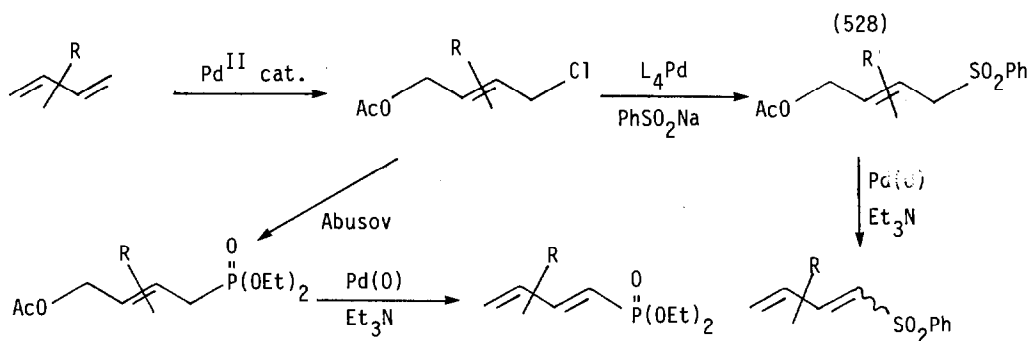

Olefins underwent clean allylic oxidation when treated with palladium(II) acetate under oxidizing conditions (equation 529) [651], (equation 530) [652]. Manganese(III) acetate acetylated conjugated enones at the  $\text{Sp}^3$   $\alpha$ -position (equation 531) [653]. Allyl sulfonates were acetylated and/or chlorinated by palladium(II) catalysts under oxidizing conditions (equation 532) [654].

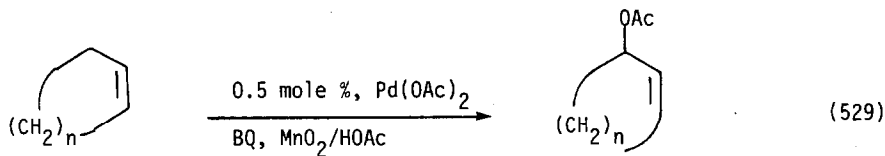
 $n = 1-4, 6$

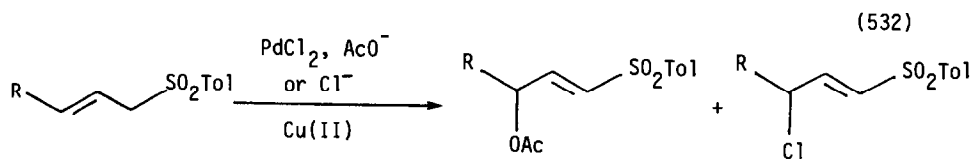
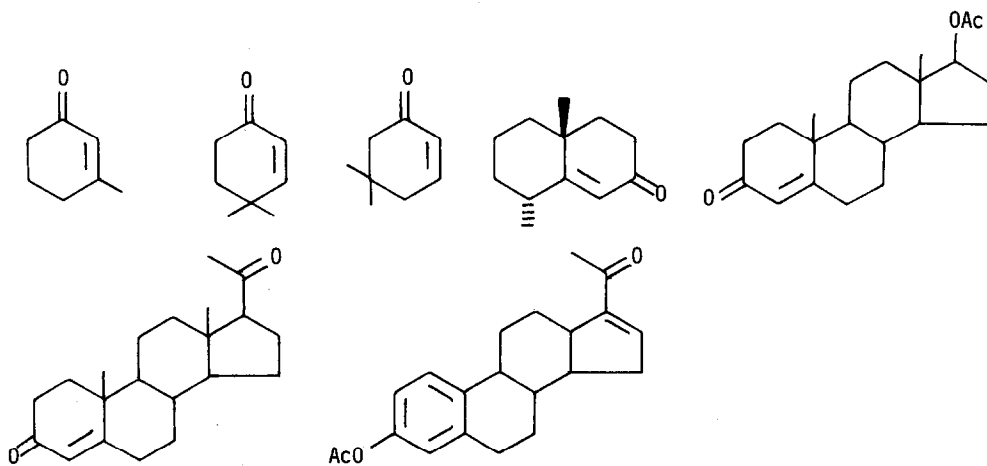
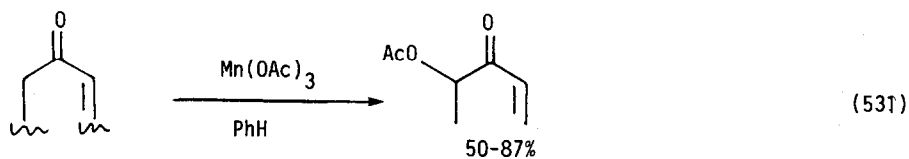
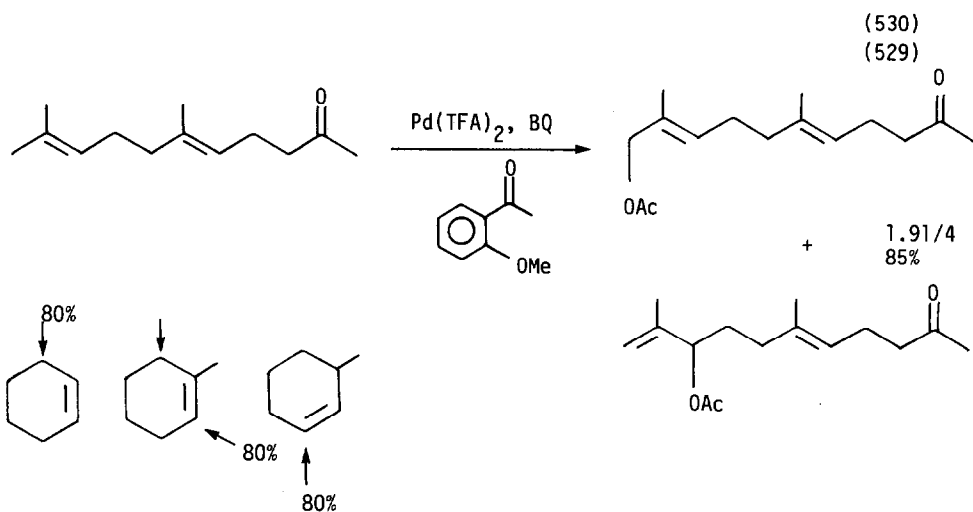

from 86:0 to 7:84 depending on conditions

Sterically hindered esters were prepared from  $\alpha$ -thiopyridyl esters and copper(II) bromide (equation 533) [655]. Allyl sulfides were converted to allyl acetates by copper/copper(II) acetate mixtures (equation 534) [656]. Alcohols were converted to esters by oxidation by ruthenium carbonyls (equation 535) [657]. Primary alcohols were oxidized to esters, secondary alcohols to ketones, and aldehydes to acids by *t*-butylhydroperoxide and a molybdenum(VI) catalyst (equation 536) [658]. 2-Ethylhexanol was oxidized to the acid by cobalt 2-ethylhexanoate catalyst [659].

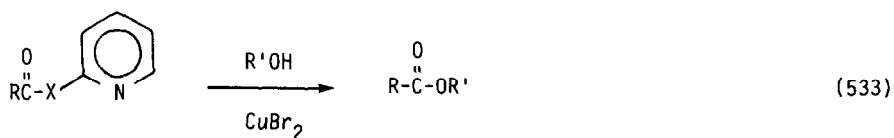

R = *n*C<sub>7</sub>; *t*Bu; Et<sub>3</sub>C; Ph; 1,3,5-Me<sub>3</sub>Ph; adamantyl

R' = *t*Bu; Et<sub>3</sub>C; 1,3,5-Me<sub>3</sub>Ph; Me

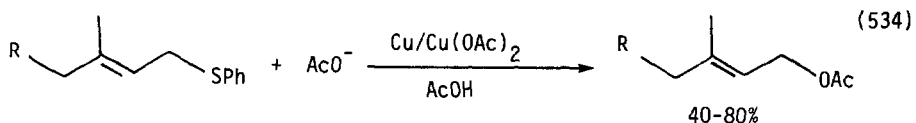

R = H, prenyl

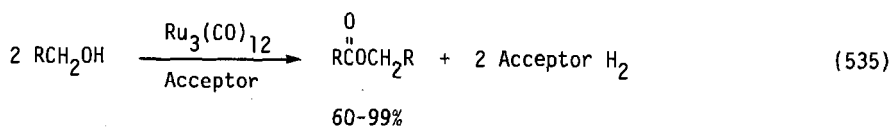

R = Et, *n*heptyl, PhCH<sub>2</sub>, 4ClPhCH<sub>2</sub>, 4MePhCH<sub>2</sub>, 4MeOPhCH<sub>2</sub>

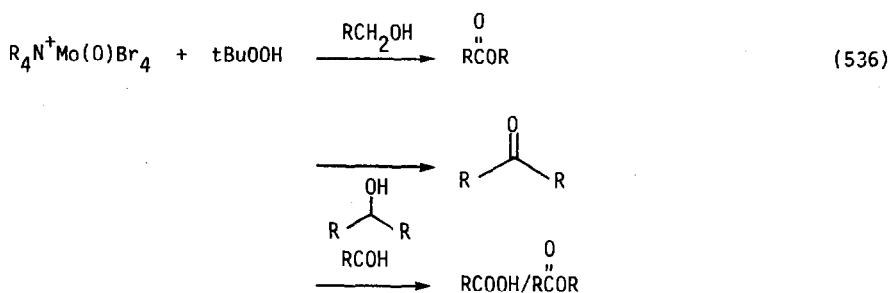

(536 continued)

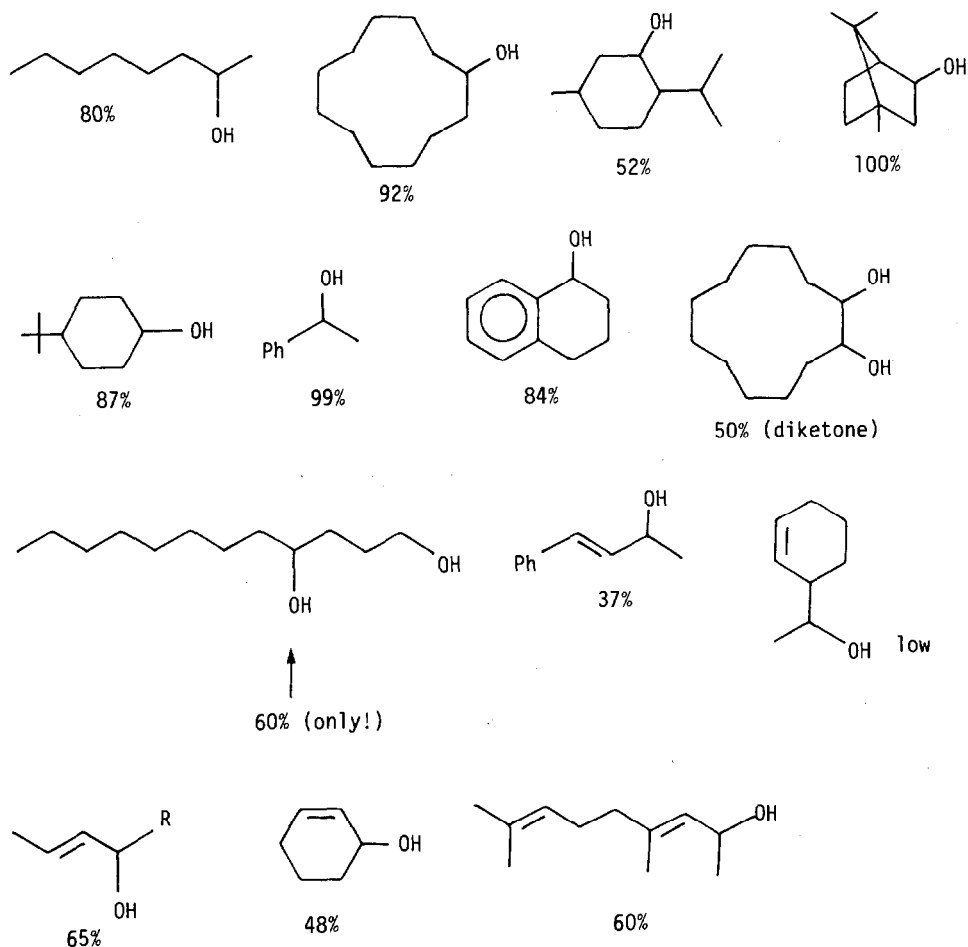

Iron(III) salts catalyzed the oxidation of  $\alpha$ -haloketones to diesters (equation 537) [660]. Styrenes were converted to monoacetates of diols by cobalt(III) acetate catalysts (equation 538) [661]. Ruthenium(II) complexes catalyzed the periodate oxidation of aromatic rings to carboxylic acids (equation 539) [662]. Enols of  $\alpha$ -diketones were oxidized to ketoacids by oxygen and copper(II) catalysts (equation 540) [663]. Ruthenium(VI) and (VII) complexes oxidized alcohols to ketones or acids [664]. Allyl esters were cleaved to the free acid by palladium(0) catalysts (equation 541) [665]. Allylic alcohols were oxidatively cleaved by *t*-butylhydroperoxide in the presence of molybdenum(VI) catalysts (equation 542) [666].

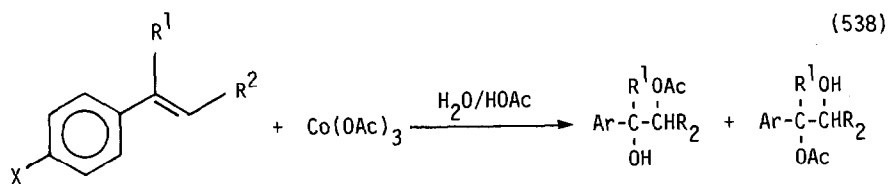
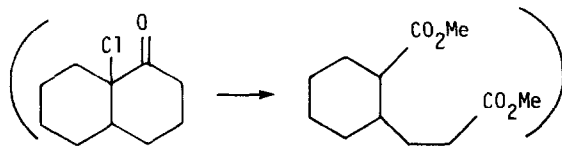
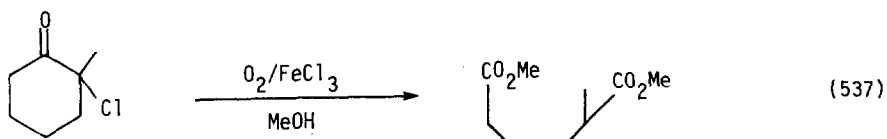

$R^1 = \text{H, Me, Ph}$

$R^2 = \text{H, Me, Ph}$

$X = \text{H, Me, Cl, Br, MeO, NO}_2$

fair to good yields

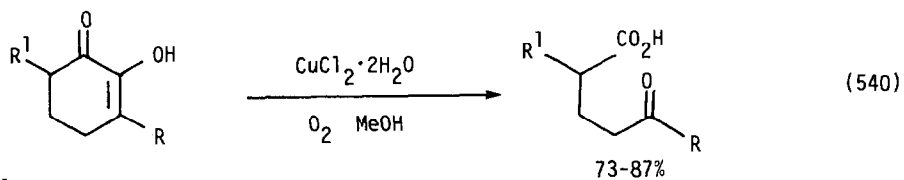
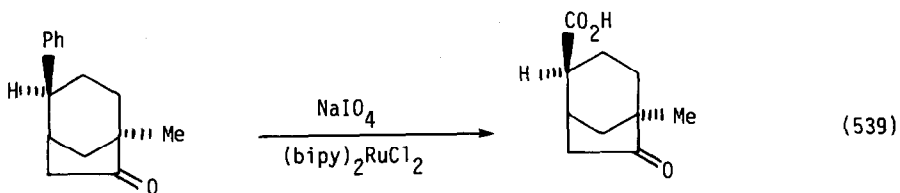

$R^1 = \text{H, iPr, Me}$

$R^2 = \text{H, Me, iPr}$

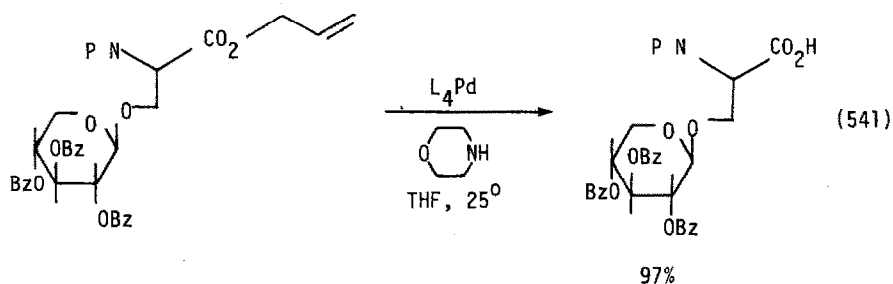

( is protecting group)

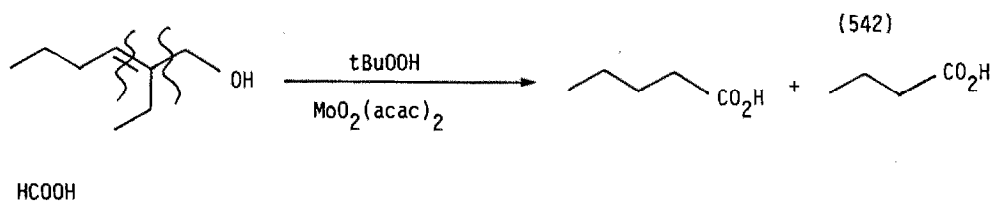

### E. Heterocycles

A number of reviews dealing with transition metal mediated heterocyclic synthesis have appeared. These include: "Catalytic Synthesis of Nitrogen Containing Heterocycles" (195 references) [667]; "Synthesis of Heterocycles via Organometallic Intermediates" (dissertation) [668]; "Heterocyclic Synthesis by Metal Carbonyl Induced Cyclization Reaction" (47 references) [669]; "Cobalt Catalysis in the Synthesis of Nitrogen-Containing Heterocycles Pt 1 The Protoberberine Alkaloids; Pt 2 Vitamin B<sub>6</sub>" (dissertation) [670]; "Reduction of Heterocyclic Compounds with Sodium Borohydride-Transition Metal Salts" [671]; and "Synthesis of Heterocycles from  $\beta$ -Dicarbonyl Derivatives of Ferrocene" [672].

Molybdenum(V) chloride dispersed on silica was an efficient catalyst for the epoxidation of cyclohexene [673]. Dicyclopentadiene was epoxidized by O<sub>2</sub> in the presence of MoO<sub>2</sub>(acac)<sub>2</sub> (equation 543) [674]. Palladium(II) acetate catalyzed the epoxidation of olefins by peresters (equation 544) [675]. Palladium(II) nitrile complexes epoxidized norbornene, but converted most other olefins to ketones [676]. Ruthenium(III) chloride catalyzed the epoxidation of olefins by periodate (equation 545) [677].  $\alpha$ -Haloepoxides could be alkylated by Grignard reagents in the presence of copper(I) catalyst (equation 546) [678].



(543)

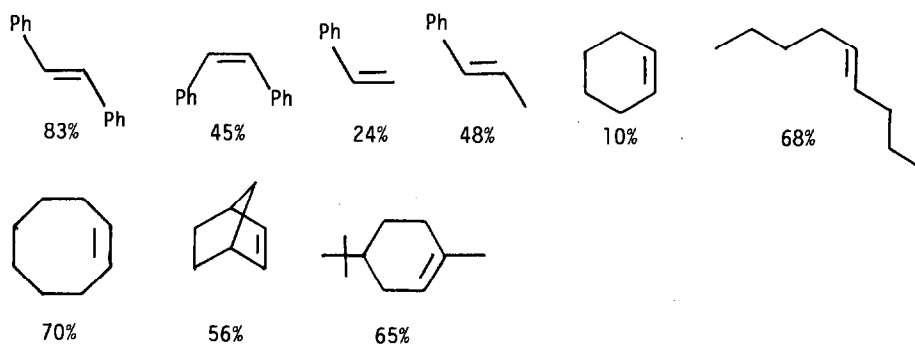
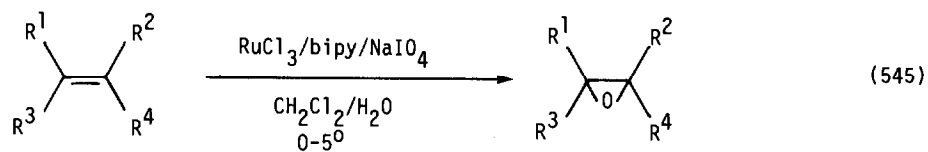
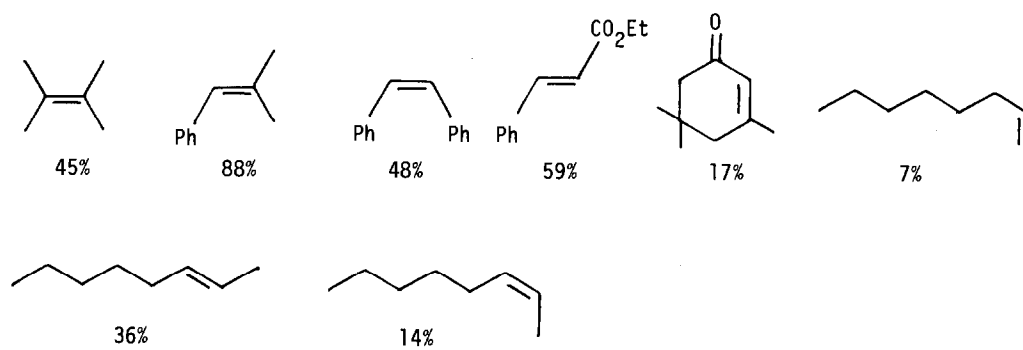
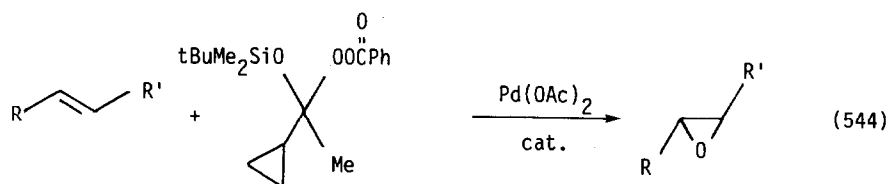
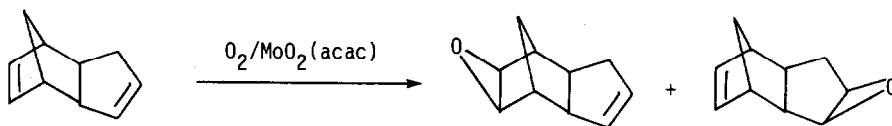

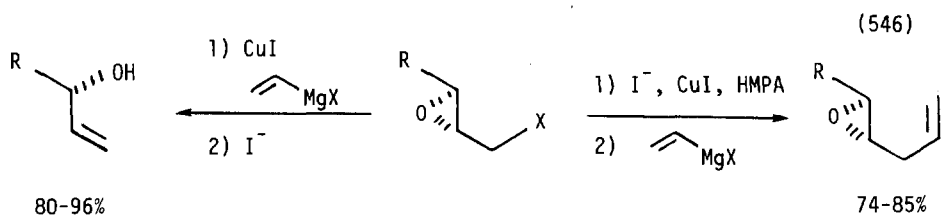

Manganese-porphyrins catalyzed the epoxidation of olefins by sodium hypochlorite (equation 547) [679], by cumyl hydroperoxide (equation 548) [680], and by hypochlorite under phase-transfer conditions (equation 549) [681][682]. Molybdenum porphyrins catalyzed the epoxidation of cyclohexene by *t*-butylhydroperoxide [683] as did other molybdenum oxo compounds [684], while molybdenum stearate was efficient for the epoxidation of trisubstituted cyclohexenes (equation 550) [685]. Complex molybdates catalyzed the epoxidation of allylic alcohols by hydrogen peroxide (equation 551) [686]. Iodosylbenzene epoxidized olefins in the presence of iron porphyrin complexes (equation 552) [687] or copper(II) nitrate [688].

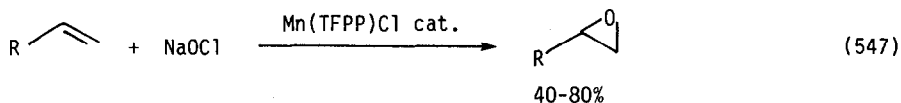

TFPP = 5,10,15,20(F<sub>5</sub>Ph)porphyrin

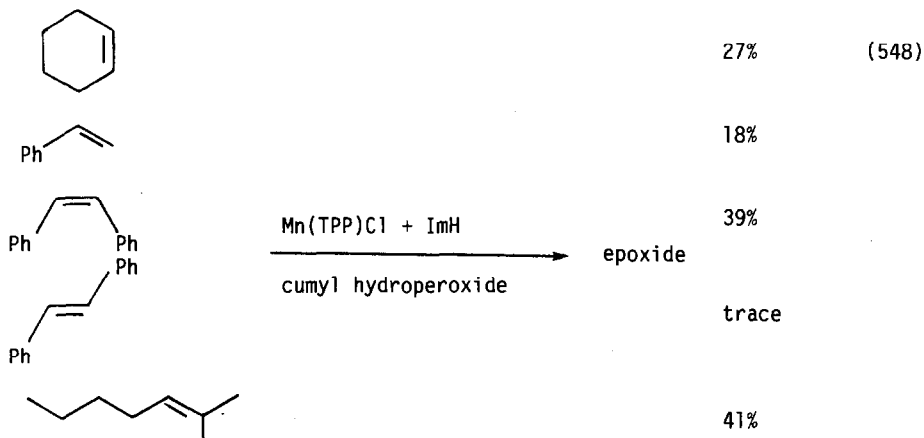
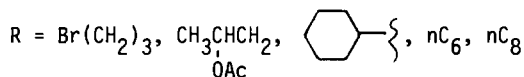

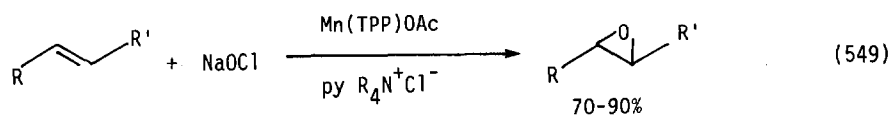

(best for di and trisubstituted olefins)

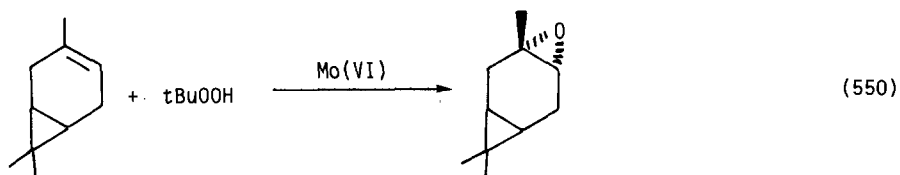

(studied ligand effects)

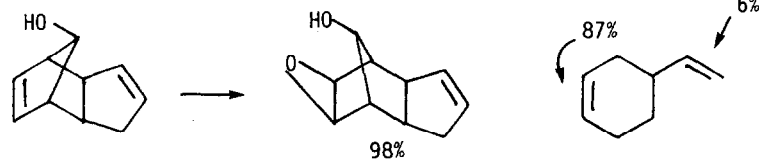
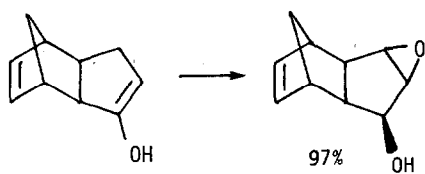
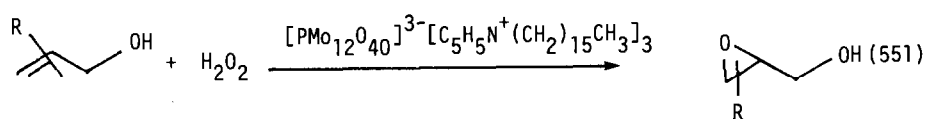

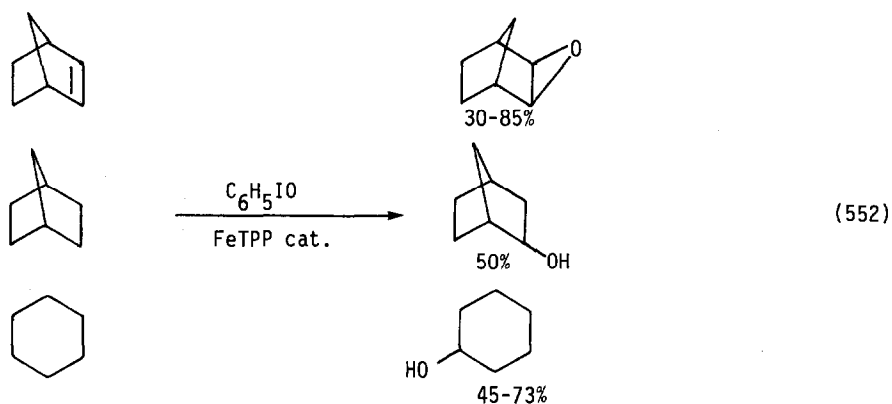

The mechanism of titanium tartrate catalyzed asymmetric epoxidation has been reviewed [689][690]. Chiral tartrate esters were linked to polystyrene resin and used as epoxidation catalysts for geraniol with *t*-butylhydroperoxide and titanium(IV) isopropoxide. Up to 66% ee was obtained [691]. Sharpless epoxidation of allylic alcohols was further examined [692]. The asymmetric epoxidation of homoallylic alcohols under "Sharpless" conditions went with only modest ee and enantioface selection was opposite that of allylic alcohols (equation 553) [693]. The chirality of epoxidation of allylic alcohols depended on the ligand to catalyst ratio (equation 554) (equation 555) [694]. The stereochemistry of  $\text{OsO}_4$  oxidation of allylic alcohols was studied and it was observed that "the relative stereochemistry between the preexisting OH or OR groups and the adjacent, newly introduced OH group of the major product is erythro in all cases [695]. Phenyl azide reacted with cyclooctene in the presence of palladium chloride to give two heterocyclic complexes (equation 556) [696]. Iron and manganese porphyrins catalyzed the conversion of stilbene to an azirine (equation 557) [697].

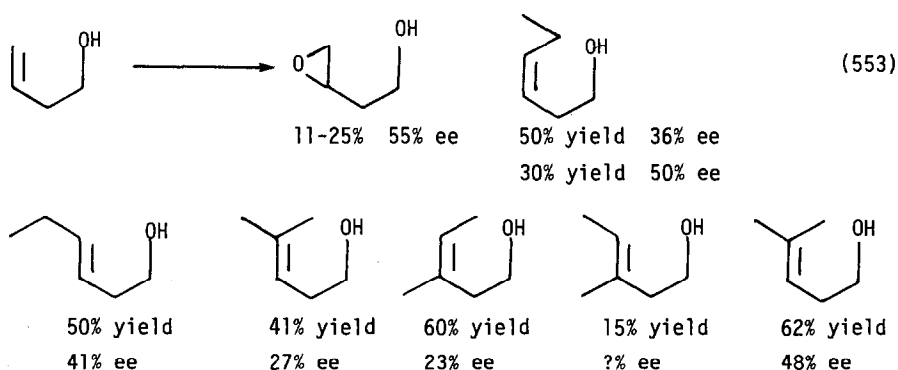

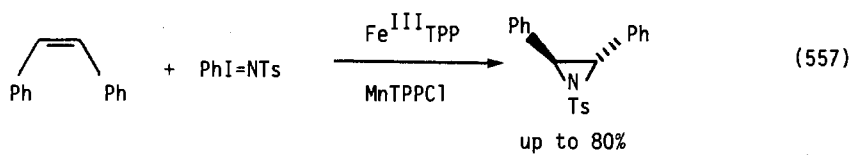
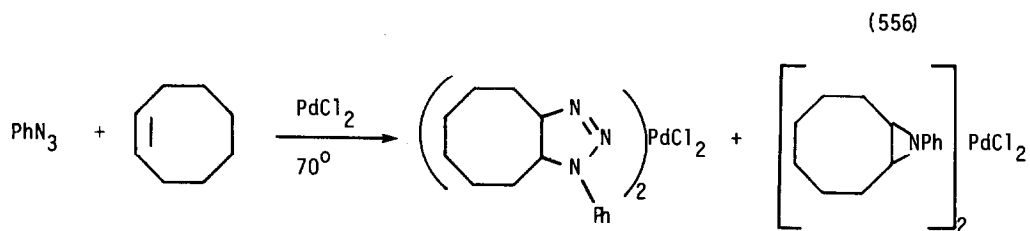
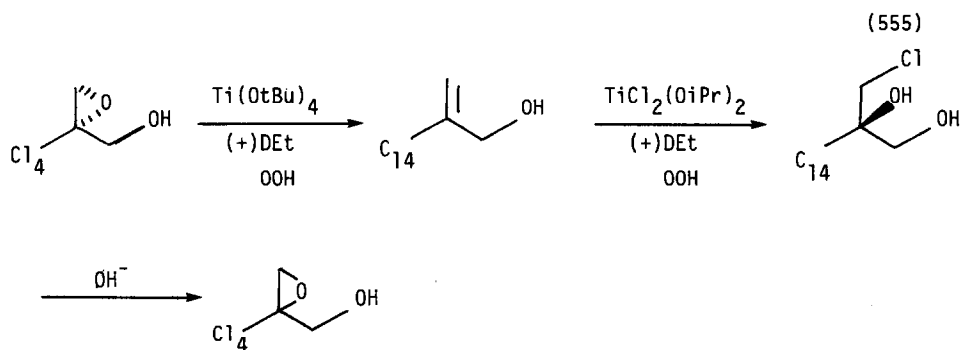
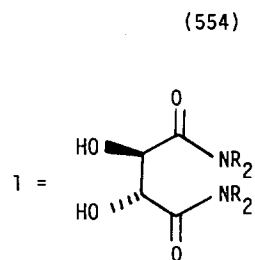
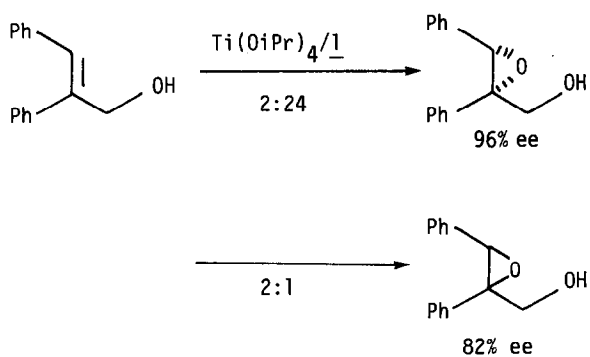

Titanium(IV) chloride converted ketene acetals and imines to  $\beta$ -lactams (equation 558) [698]. The condensation of enolates of acyliron complexes with imines went with high diastereoselectivity. Oxidative cleavage produced  $\beta$ -lactams (equation 559) [699], (equation 560) [700]. Allylic epoxides were converted to  $\beta$ -lactams via  $\pi$ -allyl iron species (equation 561) [701]. With chiral amines enantiomerically pure  $\beta$ -lactams were produced (equation 562) [702]. Carbene insertion into diazetidines gave an unexpected product (equation 563) [703]. Palladium(0) catalysts were used to cleave a new carboxy protecting group from  $\beta$ -lactams (equation 564) [704].

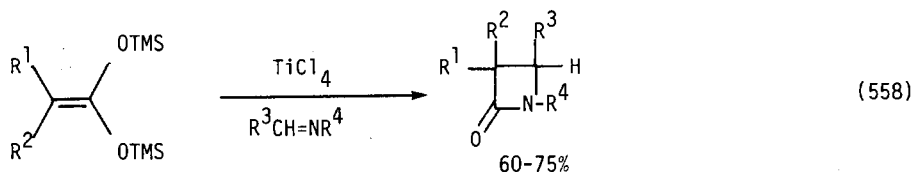

$R^1 = Me, Ph; R^2 = Me, H$   
 $R^3 = Ph, iPr; R^4 = Ph$

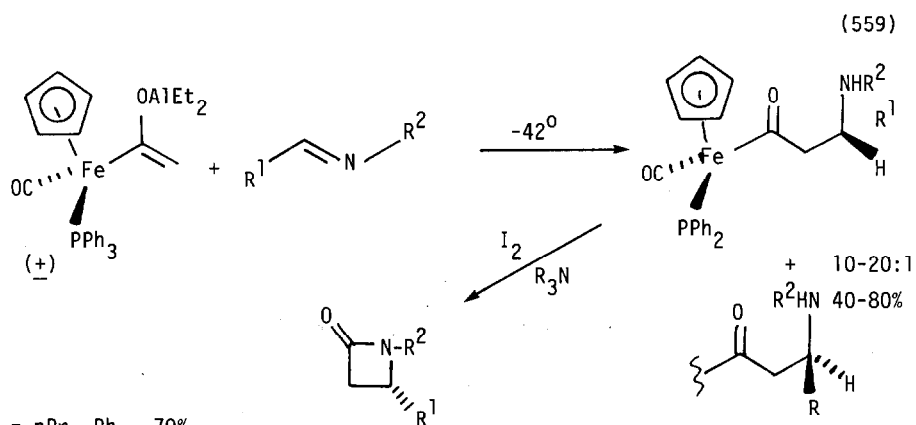

$R = nPr, Ph$  70%  
 $R's = Ph$  80%

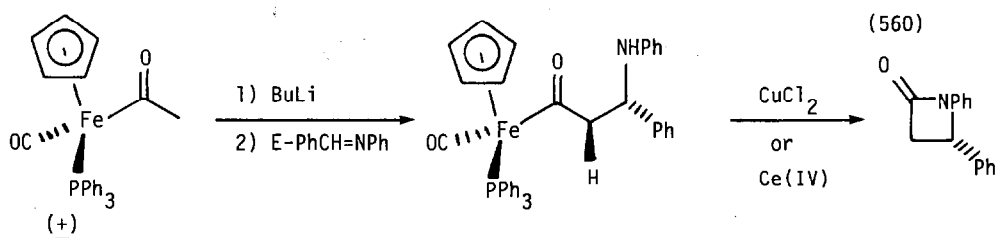

1-diastereoisomer NO CHEMICAL YIELDS!

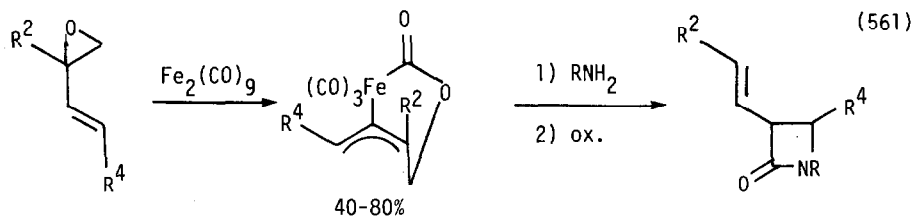

$R^2 = \text{Me, H, Ph}$

$R^4 = \text{H, Ph, C}_6$

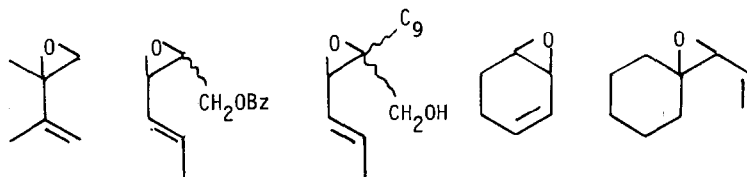

also work

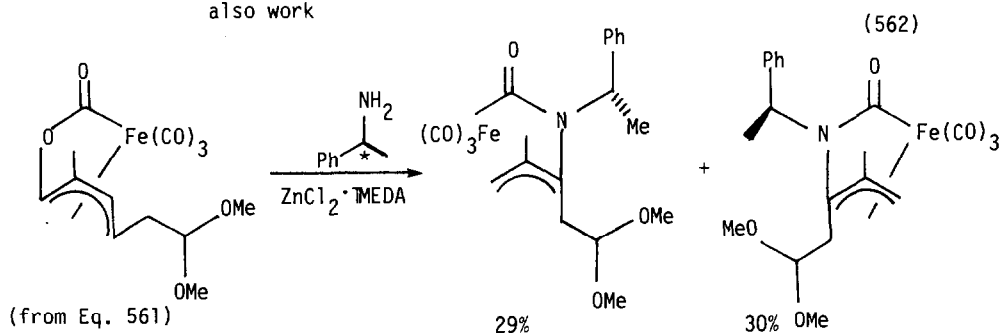

(from Eq. 561)

29%

30%

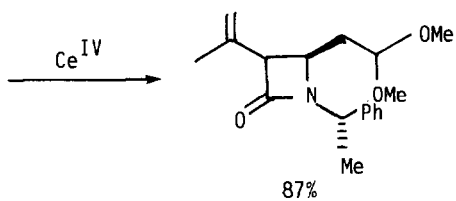

87%

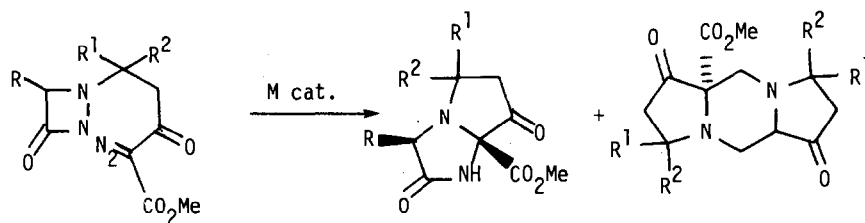

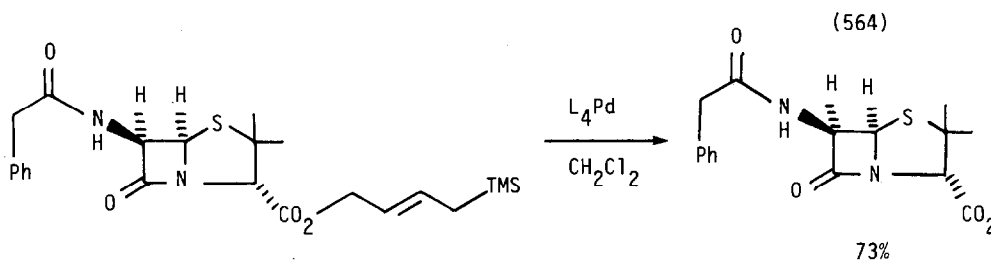

$\alpha$ -Lactams were ring expanded by reaction with carbon monoxide in the presence of cobalt or rhodium carbonyl catalysts (equation 565) [705]. Aziridines were converted to cyclic imides by molybdenum hexacarbonyl (equation 566) [706]. Azonidines were ring-opened to metallacycles by metal carbonyl hydrides (equation 567) [707].

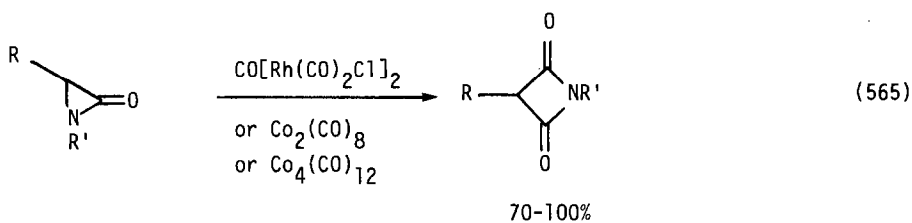

R, R' = t-Bu, adamantyl

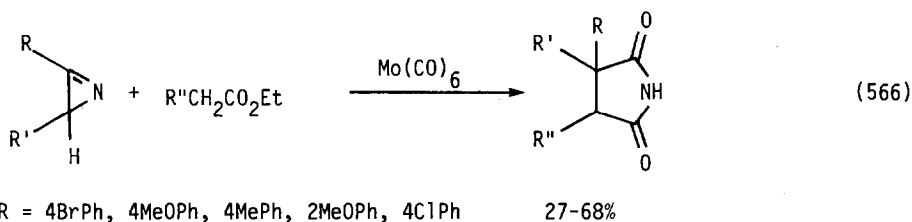

R = 4BrPh, 4MeOPh, 4MePh, 2MeOPh, 4ClPh

R' = H; R'' = CO<sub>2</sub>Et, CN, PhCO

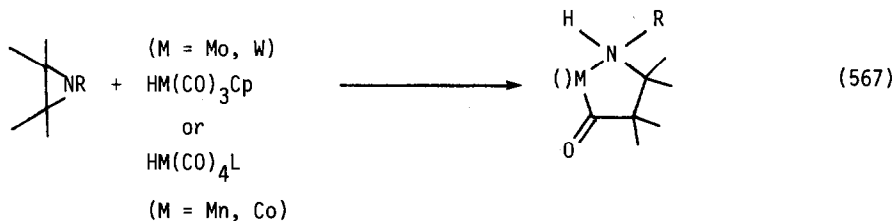



Nicotine was oxidized to a number of products by periodate in the presence of ruthenium(IV) oxide (equation 568) [708]. Cyclic amines were electrochemically oxidized to lactones in the presence of ruthenium tetroxide (equation 569) [709].  $\omega$ -Olefinic trichloro acetamides cyclized to lactones when treated with ruthenium(III) or copper(II) complexes (equation 570) [710]. Lactams were also formed by photolysis iron-diene complexes (equation 571) [711]. The Lewis-acid assisted reactions of N-acylimidazoles with transition-metal nucleophiles was the topic of a dissertation [712].

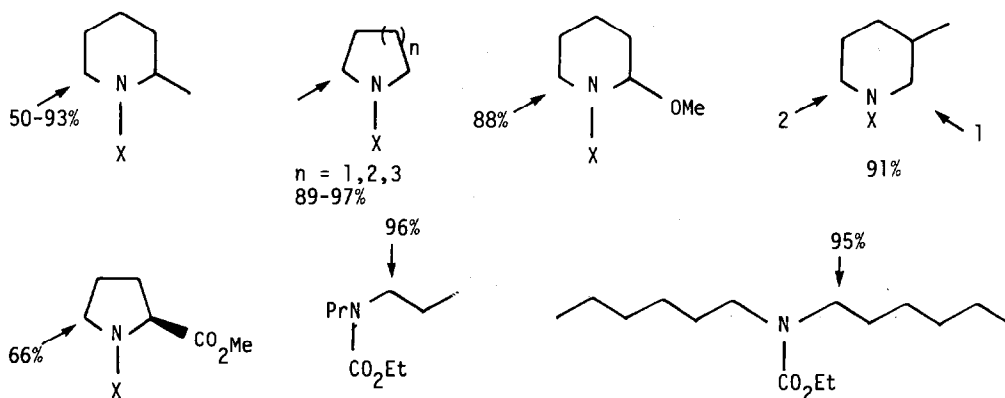
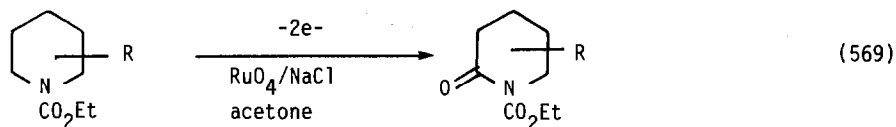
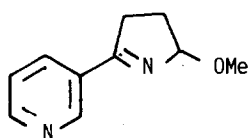
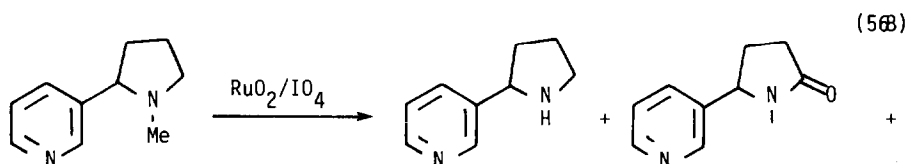

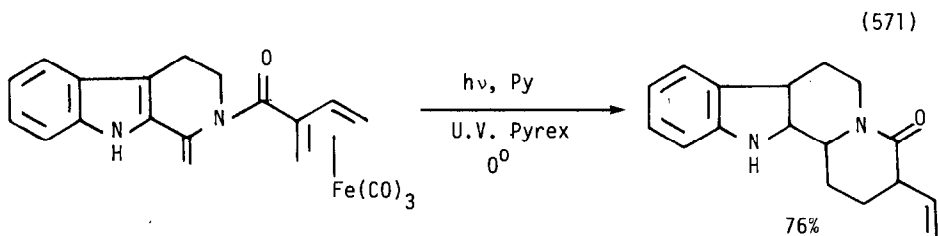
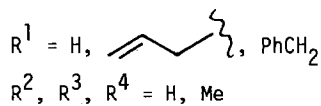
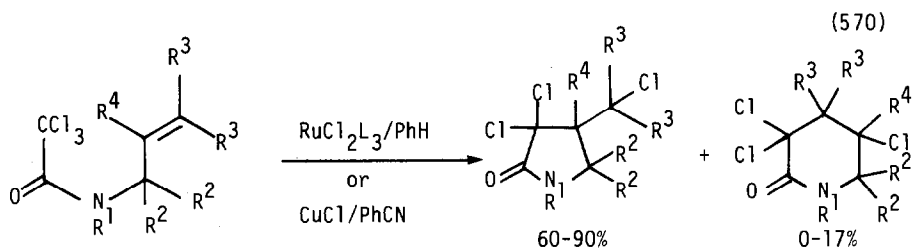

Palladium catalyzed synthesis of heterocycles (particularly pyrroles and furans) has been reviewed (13 references) [713]. Copper(II) chloride catalyzed the condensation of  $\beta$ -ketoamides with diazo compounds to form pyrroles (equation 572) [714][715]. Titanium(III) chloride deoxygenated N-hydroxyimidazoles (equation 573) [716]. Azobenzenes were cyclized to indazoles diazaheterocycles by palladium chloropalladate via an *ortho* metallation process (equation 574) [717]. Low valent cobalt salts catalyzed the reduction of N-substituted pyridinium salts to dihydropyridines [718].

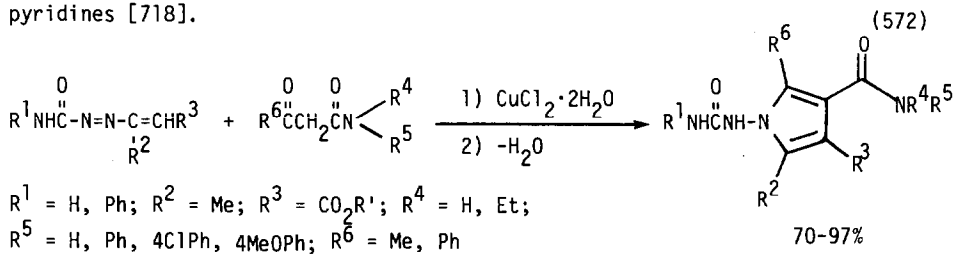

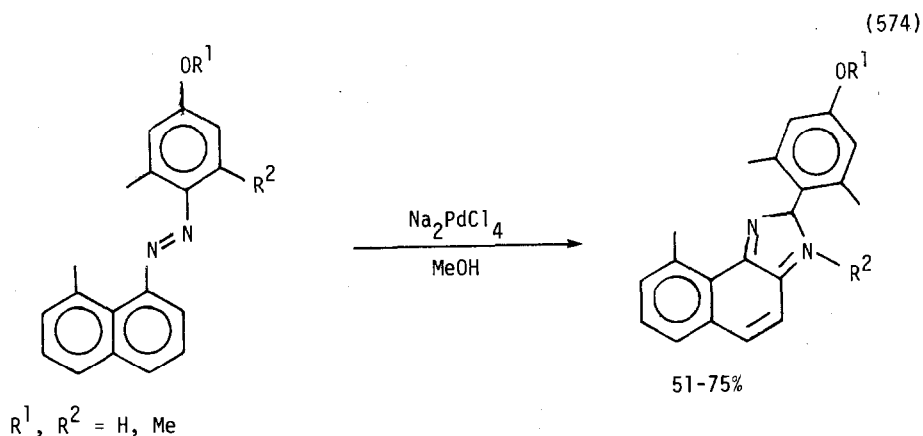
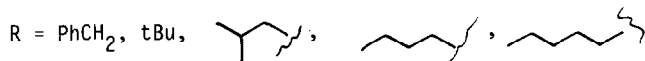
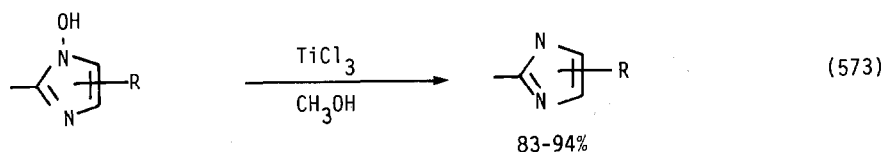

Benzopyrans were produced from fluorobenzenes having alcoholic side chains by treatment with a rhodium(III) complex catalyst (equation 575) [719]. Copper(II) catalyzed the insertion of diazoketones into arenes to give benzopyrans (equation 576) [720]. Dihydrofurans were produced in the copper metal catalyzed condensation of  $\alpha,\alpha$ -dibromo 1,3-diketones with olefins (equation 577) [721]. 2-Vinyl-1,4-dioxane was prepared from butadiene or dichlorobutenes by using a variety of catalysts including CuCl, PdCl<sub>2</sub>, CuCl<sub>2</sub>, CrCl<sub>3</sub>, HgCl<sub>2</sub>, ZnCl<sub>2</sub>, and FeCl<sub>3</sub> [722][723].

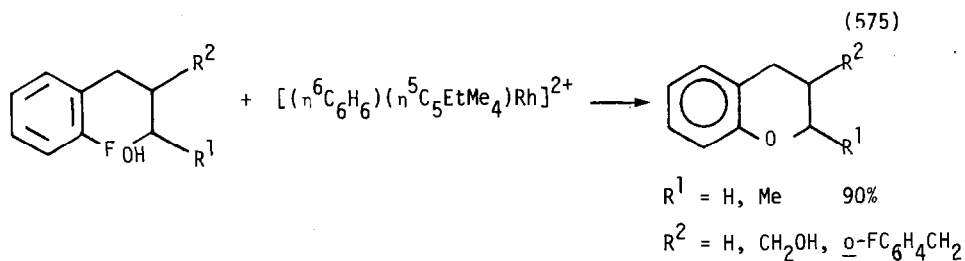

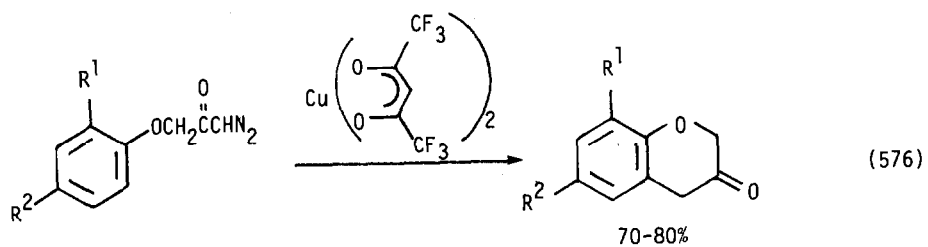

$R^1, R^2 = H, Me, tBu$

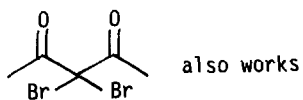
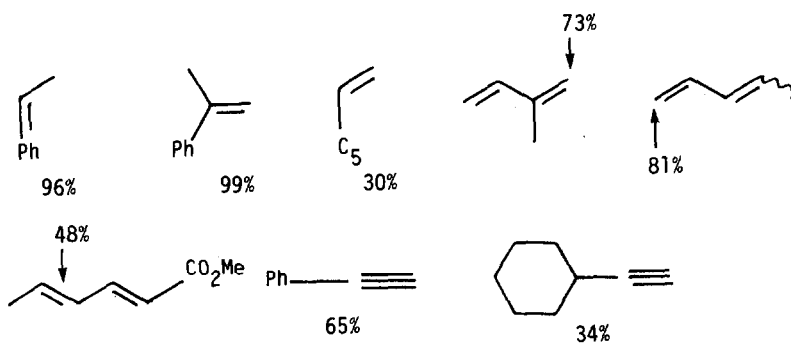
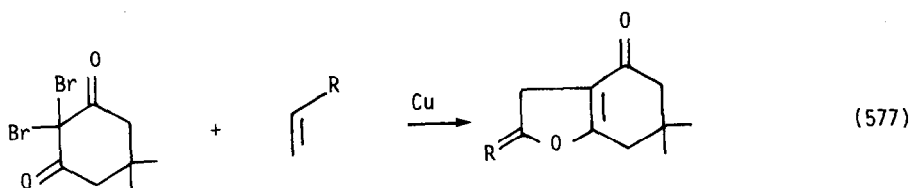
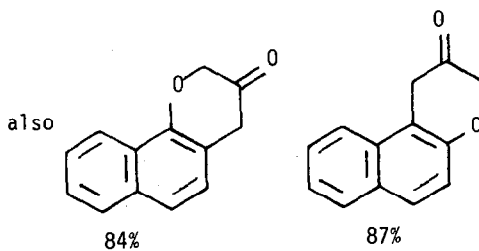

The detailed mechanism of palladium catalyzed  $\alpha$ -methylene lactone synthesis from acetylenic alcohols has been studied and is as shown in equation 578 [724]. Cyanoacetic acid reacted with cyclohexene in the presence of manganese(II) acetate to give  $\alpha$ -cyanolactones (equation 579) [725]. Malonic acid behaved in a similar manner (equation 580) [726].  $\alpha$  Hydroxylactones were oxidized to pyruvyl lactones by oxygen and ruthenium dioxide (equation 581) [727]. Chromyl chloride cyclized olefinic alcohols to lactones (equation 582) [728].

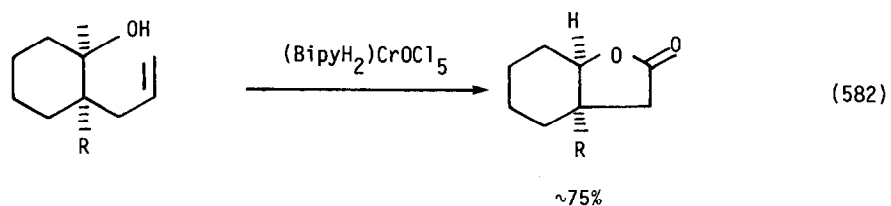
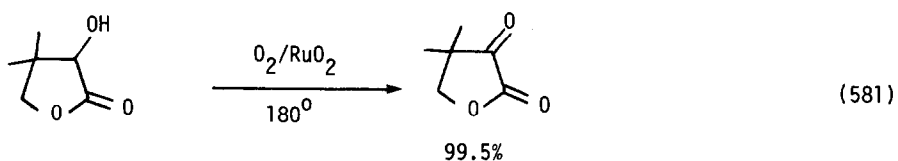
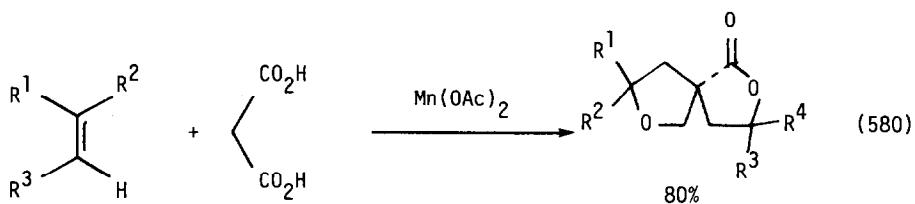
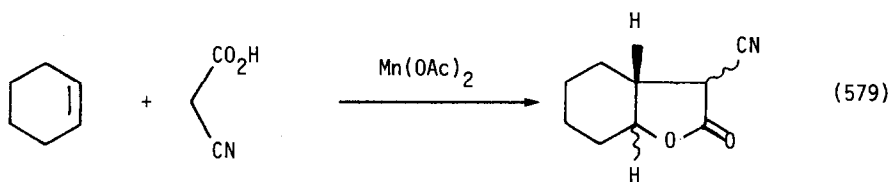
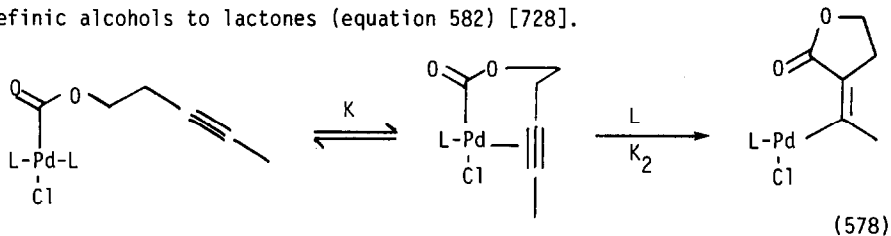

Indoles were prepared by the copper(I) iodide catalyzed reaction of *o*-iodoaniline with ketone enolates (equation 583) [729]. Ruthenium(III) chloride catalyzed the formation of quinolines from alcohols and nitrobenzenes at high temperatures (equation 584) [730]. Palladium(0) complexes promoted the formation of carbazoles (equation 585) [731]. Manganese(II) acetate catalyzed the cyclo-trimerization of trichloroacetonitrile (equation 586) [732]. Cyanogen and  $\beta$ -diketones combined to form pyrimidines in the presence of a number of transition metal complexes (equation 587) [733]. Molybdenum(0) was used as a template to assemble a macrocyclic poly thio ether (equation 588) [734]. Cyclic sulfones formed from 4-pentenylcobalt complexes and trichloromethylsulfonyl chloride (equation 589) [735].

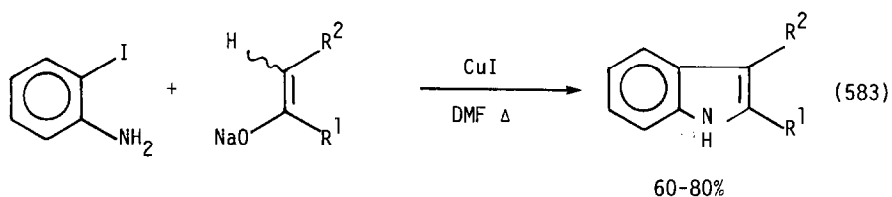

$R^1 = \text{Me, Et, CH}_2\text{CO}_2\text{Et}; R^2 = \text{CO}_2\text{Et, COMe, CPh}$

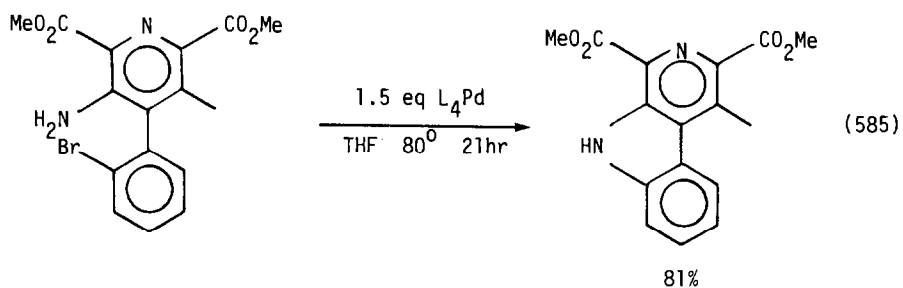
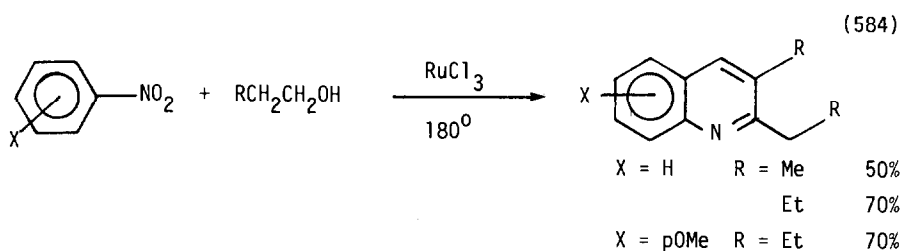

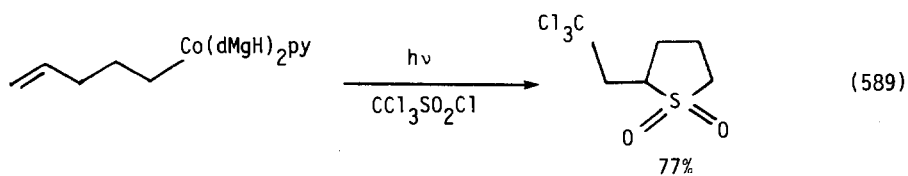
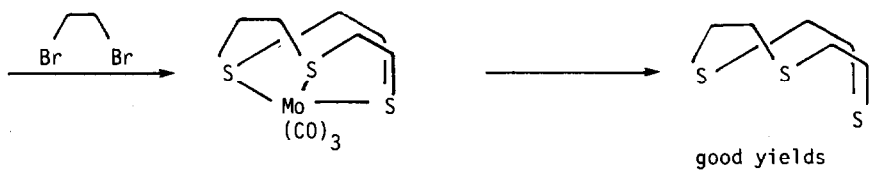
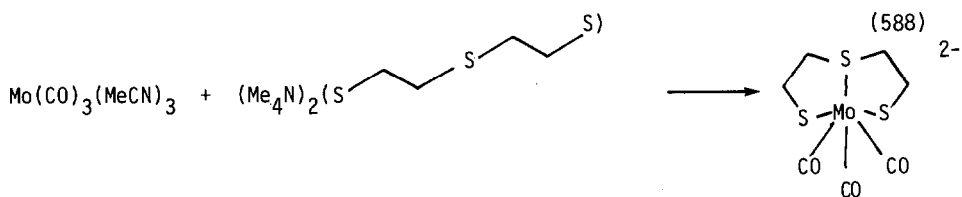
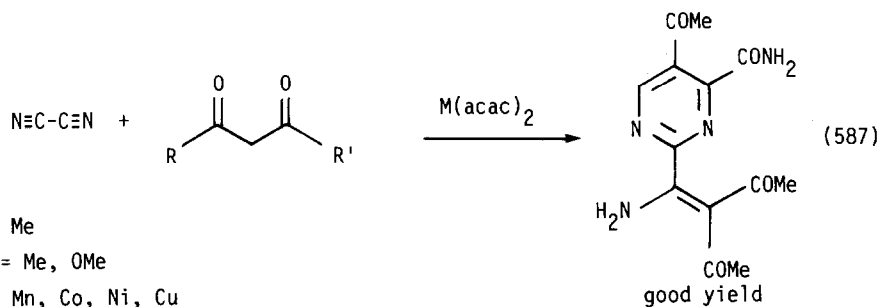
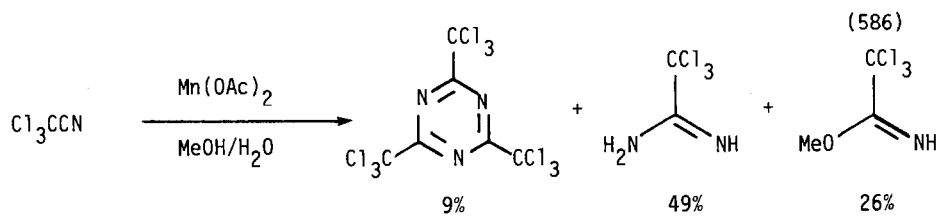

## F. Alkenes

Allylic chlorides were converted to dienes by treatment with palladium acetate at high temperature (equation 590) [736]. Allyl acetates underwent a similar conversion in the presence of palladium(0) complexes (equation 591) [737].  $\beta$ -Aminoketones were oxidized to vinylogous amides by palladium(II) chloride (equation 592) [738]. A cheap, fast and convenient method for the conversion of *vic* dibromides to olefins involved the use of zinc in THF with a  $Cp_2TiCl_2$  catalyst [739]. Squalene was produced by photolytic destruction of a  $\pi$ -farnesylpalladium complex [740]. Endo peroxides were converted to dienes by reduced titanium species (equation 593) [741].

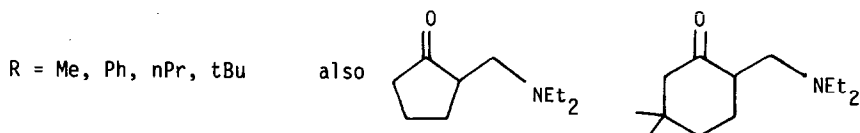
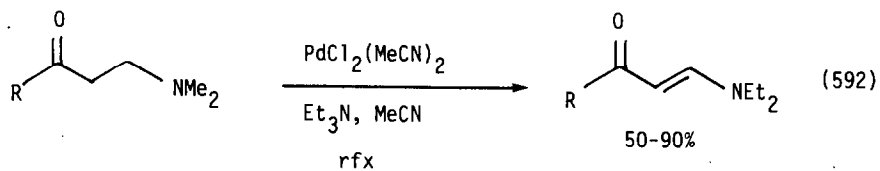
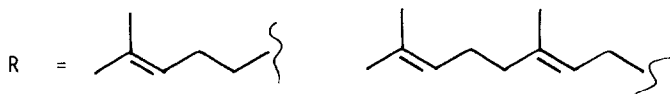
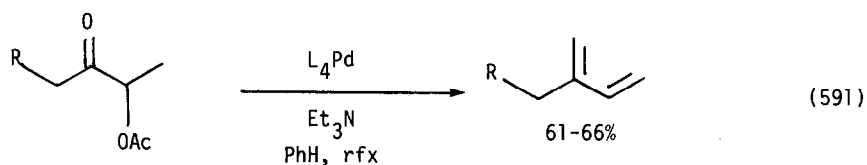
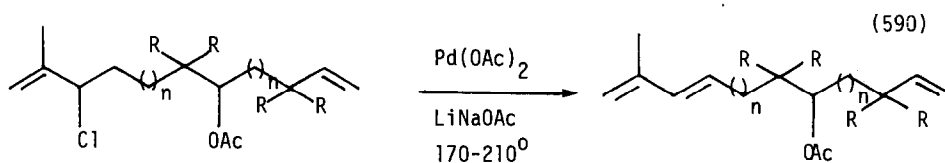



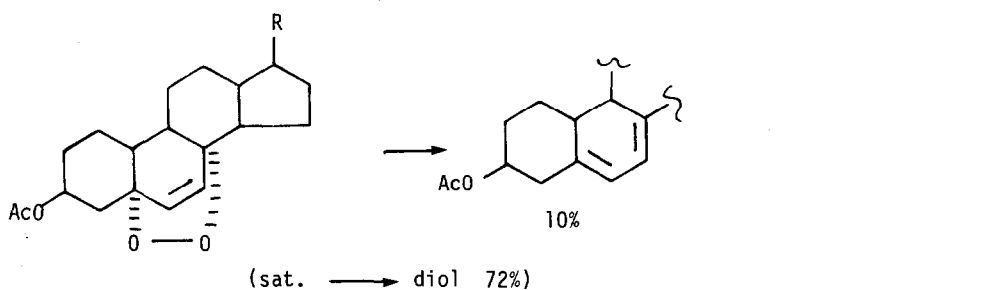
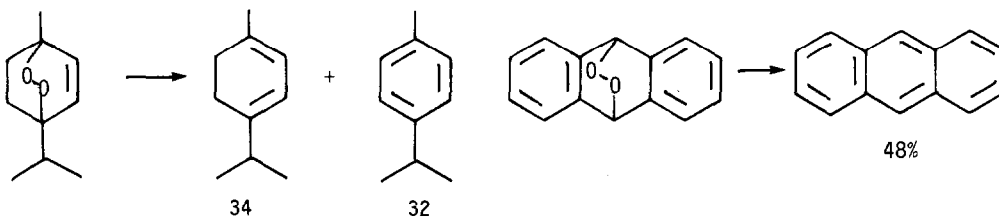
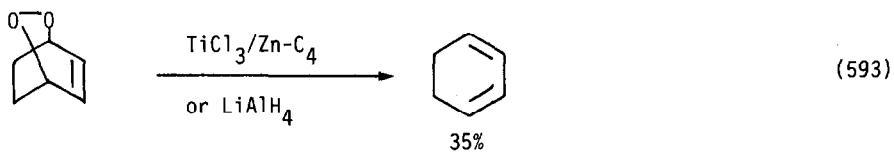

Vinyl triflates were reduced to olefins by palladium(II) acetate/formic acid (equation 594) [742]. Allylacetates, ethers, carbonates and chlorides were similarly reduced (equation 595) [743]. Palladium(0) complexes catalyzed the hydride reduction of propargyl mesylates or phosphonates to mixtures of allenes and alkynes (equation 596) [744]. A number of low valent metal hydridocarbonyl complexes efficiently reduced halides to hydrocarbons (equation 597) [745]. An efficient hydrozirconation agent for terminal olefins has been developed (equation 598) [746].  $\eta^6$ -Benzene complexes of iridium were reduced stepwise to cyclohexene (equation 599) [747].

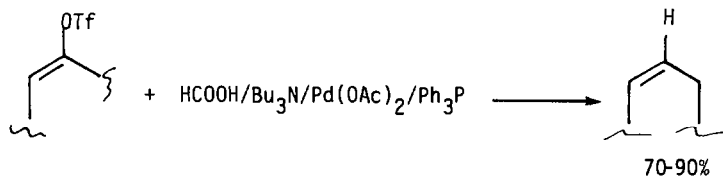

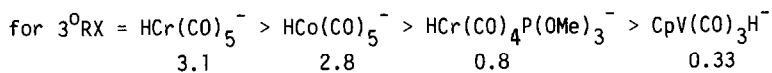
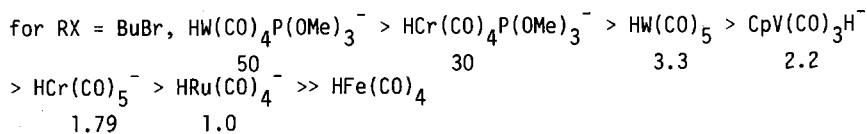
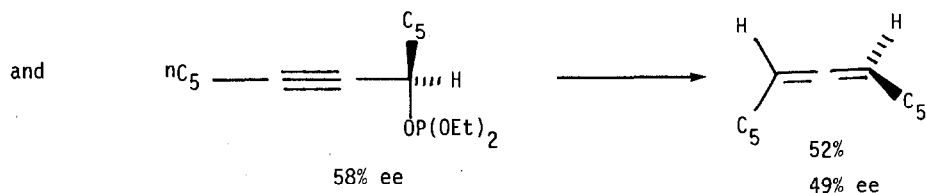
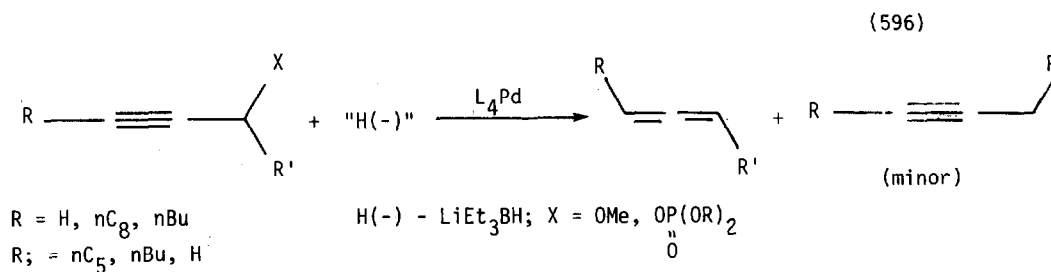
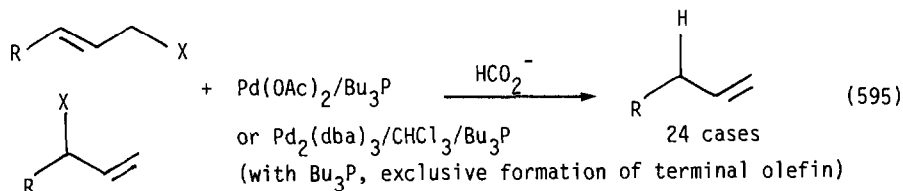

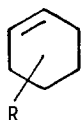
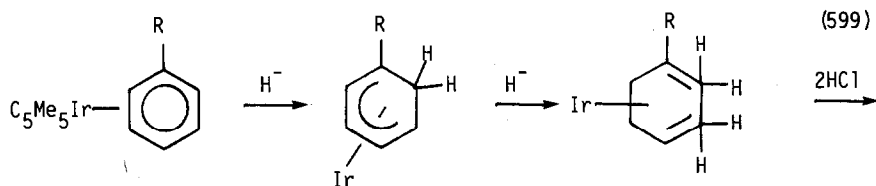
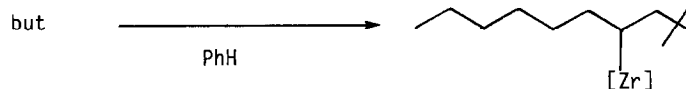
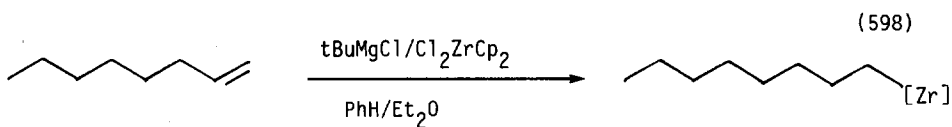

R = H, Me, tBu, OMe, Cl

Cyclohexadiene and tetrahydronaphthalene disproportionated over Ziegler catalysts [748]. Nickel complexes catalyzed the reaction between methylmagnesium bromide and alkynyl silanes [749]. Trimethylsilylenol ethers were generated from ketones using *in situ* generated iron(0) complexes (equation 600) [750], (equation 601) [751]. Palladium(II) chloride catalyzed the conversion of  $\alpha$ -halo ketones to silylenol ethers (equation 602) [752]. The catalysts  $(iPr_3P)_2IrH$ ,  $[(pFPh)_3P]_2IrH$ , and  $[p(FPh)_3P]_2Ru$  converted cyclooctane to cyclooctene [753]. Alkanes were converted to terminal alkenes by  $L_2ReH_7$  in the presence of hydrogen acceptors.

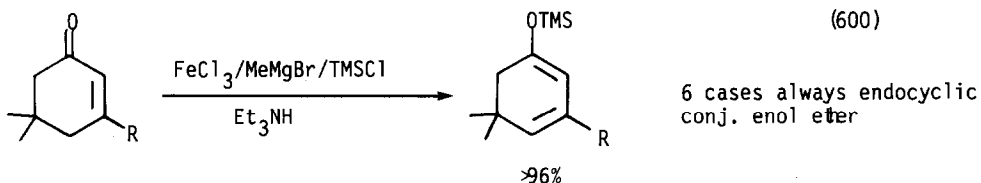

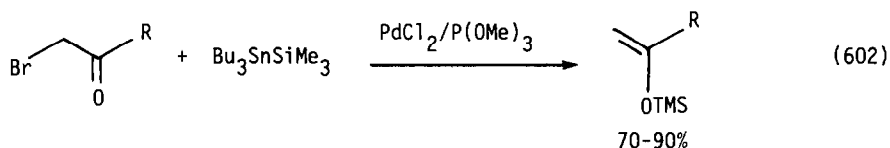
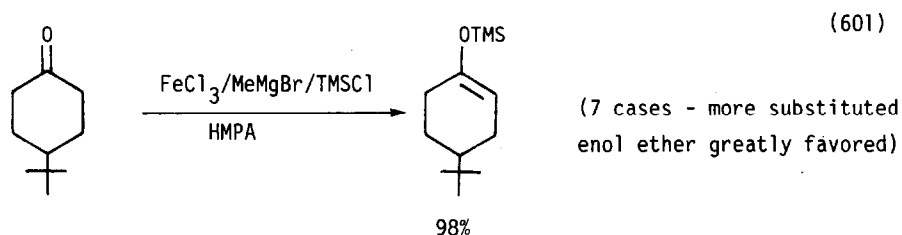

R = Me, Et, iPr, tBu

## 6. Ketones, Aldehydes

A number of oxidation systems to convert alcohols to ketones or aldehydes have been developed. A number of ruthenium complexes convert alcohols to ketones using *t*-butylhydroperoxide as an oxidant (equation 603) [755], (equation 604) [756]. Secondary alcohols were oxidized to ketones by oxygen in the presence of  $\text{L}_3\text{RhCl}_3$  [757] or  $\text{RhCl}_3$  itself [758]. Rhodium(III) tetraphenylporphyrin complexes catalyzed the photooxidation of isopropanol to acetone [759]. Hydrogen peroxide oxidized alcohols to ketones in the presence complex molybdates (equation 605) [760]. By controlling pH, the 2° alcohols could be oxidized in the presence of 1° alcohols, oxidation exceeded peroxidation, and hindered alcohols oxidized faster than nonhindered ones. Platinized titanium dioxide catalyzed the photooxidation of alcohols to ketone (equation 606) [761]. Primary alcohols were oxidized to aldehydes by air and amine oxides in the presence of copper(I) chloride (equation 607) [762]. Ruthenium oxide oxidized allylic alcohols to conjugated aldehydes (equation 608) [763]. Alkoxides of lanthanides catalyzed the *t*-butylhydroperoxide oxidation of allyl alcohols to unsaturated aldehydes [764]. Acidic osmium tetroxide oxidized alcohols to aldehydes or ketones in good yield. Some selectivity was observed (equation 609) [765].

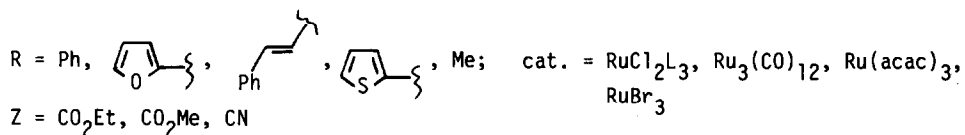
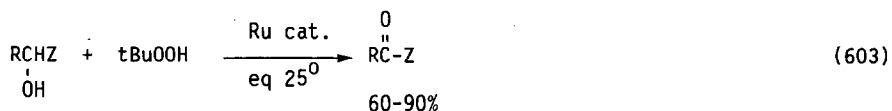

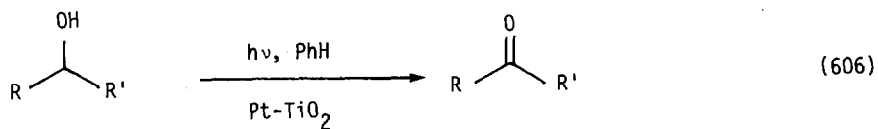
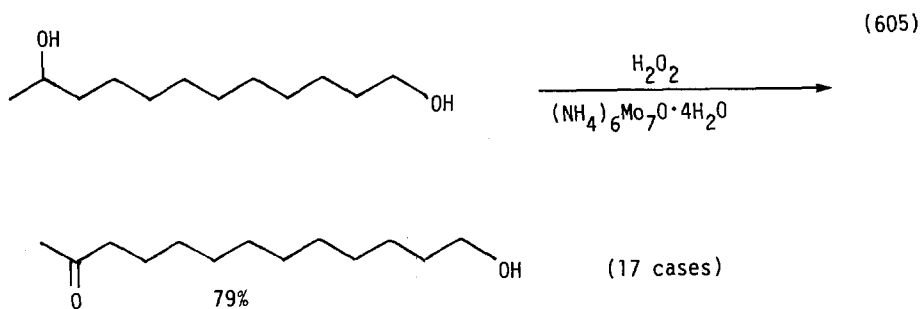
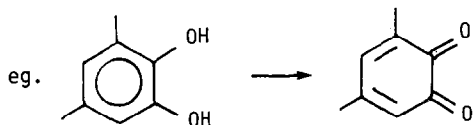
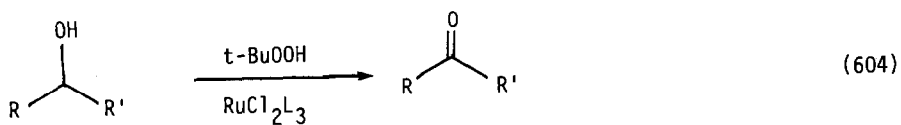

R = R' = Ph, 98%; R = Bz, R' = Me, 83%; R = H, R' = nC<sub>9</sub>, 70%

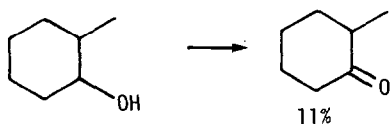
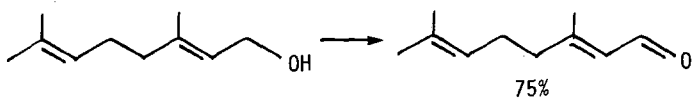

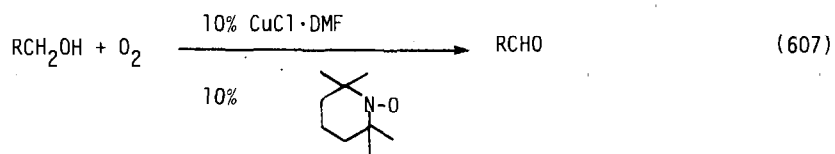

R = 4MeOPh, Ph, 4NO<sub>2</sub>Ph,

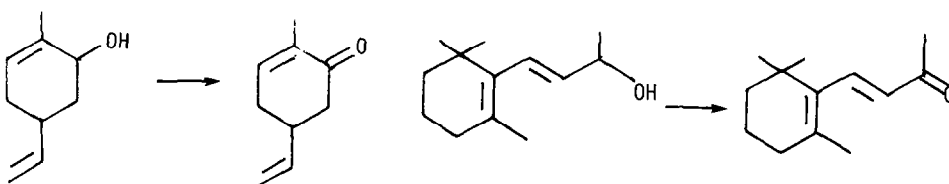
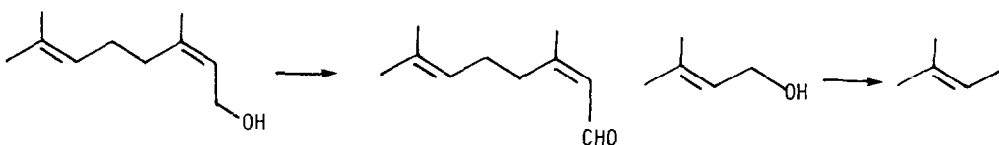
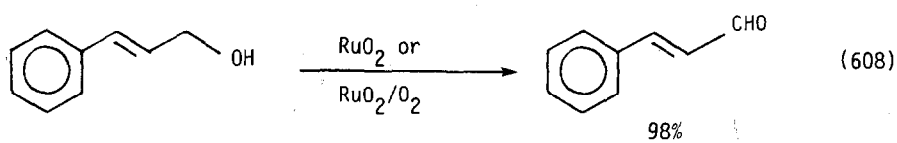
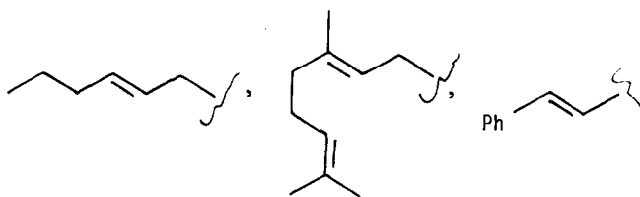

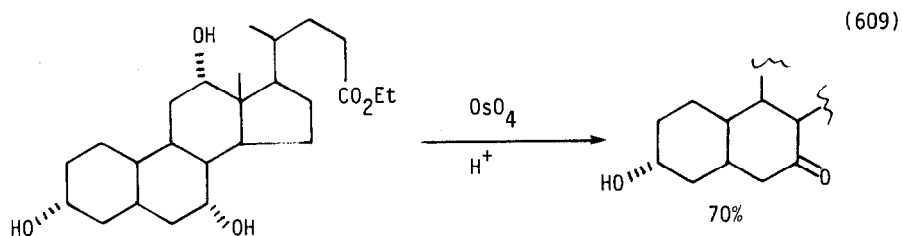

Synthetic applications of the palladium-catalyzed oxidation of olefins to ketones has been reviewed [766].  $\alpha$ -Pinene was oxidized to verbenol and verbenone by palladium(II) chloride/copper chloride catalysts [767][768]. Phosphomolybdic acid at a pH of less than 1 served as a reoxidant for palladium in the Wacker oxidation of olefins to ketones [769]. Carbon-supported palladium/vanadyl sulfate/sulfuric acid catalyst systems were used for heterogeneous Wacker oxidations [770]. Olefins were oxidized to carbonyl compounds by palladium(II) nitro complexes via a metallacycle intermediate (equation 610) [771]. Metal nitro complexes as oxygen transfer agents: selective oxidation of organic substrates by molecular oxygen was reviewed (48 references) [772]. The mechanism of the rhodium-catalyzed oxidation of 1-octene to 2-octanone by dioxygen in ethanol has been studied [773]. osmiumtetroxide oxidized benzofurans to hydroxy aldehydes, whereas palladium(II) copper(I) systems gave hydroxy esters (equation 611) [774]. Chromium hexacarbonyl catalyzed the *t*-butylhydroperoxide oxidation of olefins to conjugated enones (equation 612) [775]. Chromium(II) chloride reduced nitroolefins to conjugated enones (equation 613) [776].

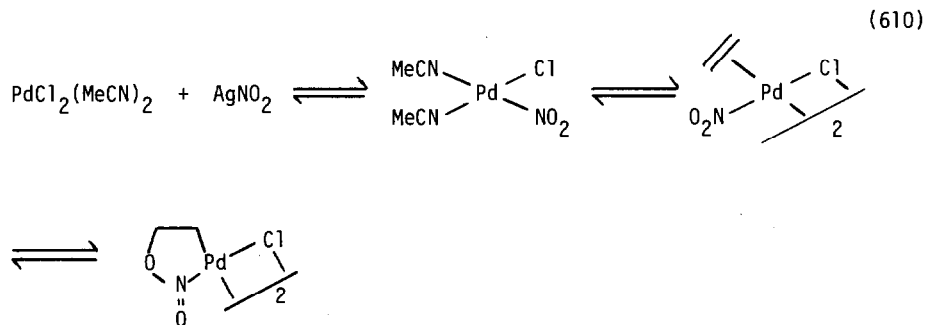

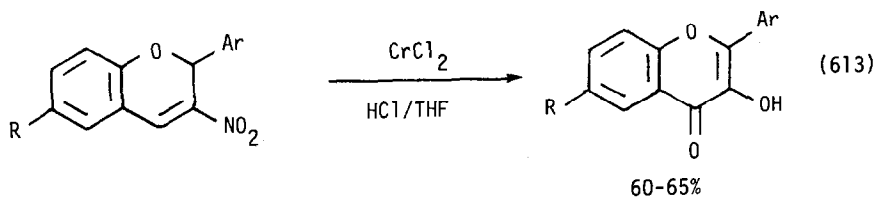
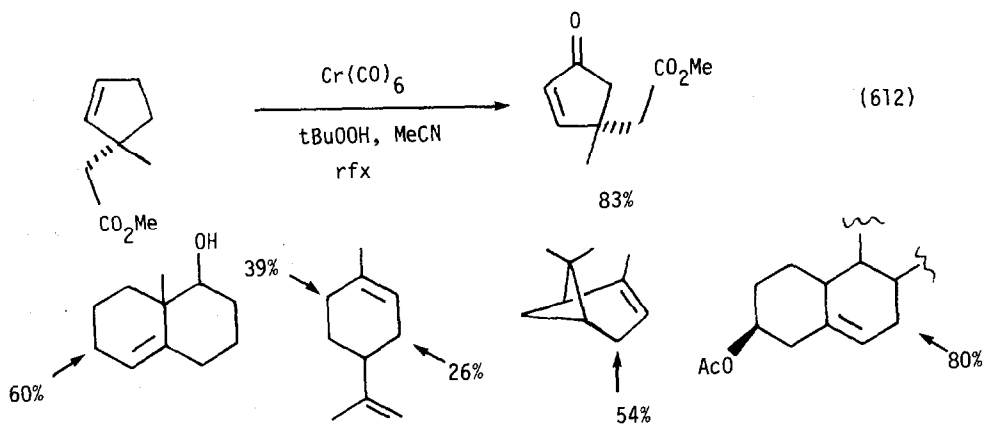
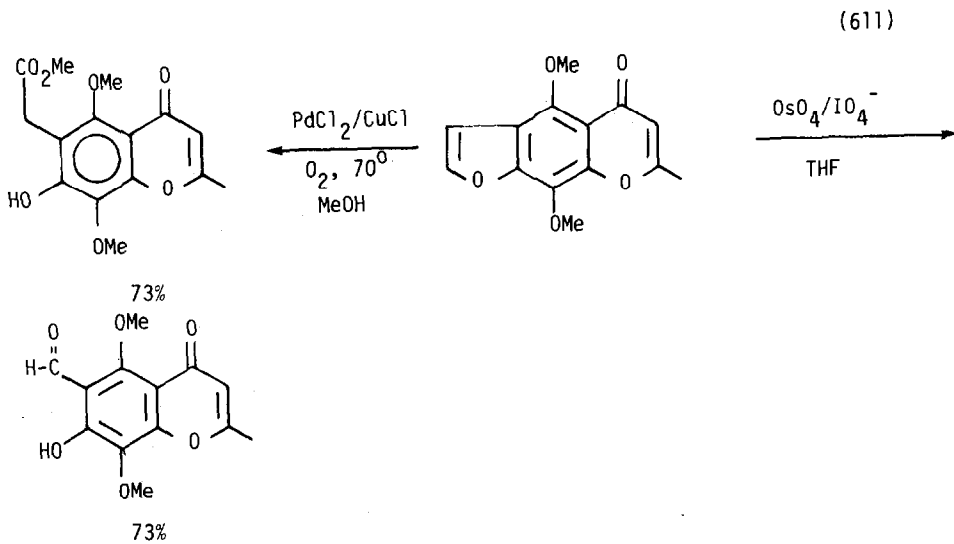



Alkanes were oxidized to 2° alcohols or ketones by vanyl peroxides [777]. 1,4-Cyclohexadienes are aromatized by oxygen and rhodium(II) acetate, but 9,10-dihydroanthracene is oxidized to anthraquinone [778]. 2,6-Ditertiary butylphenol was oxidized to the quinone by a variety of metal-prophyrin complexes [780]. The order of reactivity was: CoTPP >> FeTPPCl > MnTPPCl > VOTPP. Cyclic oximes were oxidatively cleaved to ketones and aldehydes by irradiation in the presence of  $\text{Fe}(\text{CO})_5$  (equation 614) [781]. Phenylacetic acids were oxidized to aryl ketones by copper(I) salts and oxygen (equation 615) [782]. Isonitriles condensed with palladium enolates to give vinylogous amides (equation 616) [783].

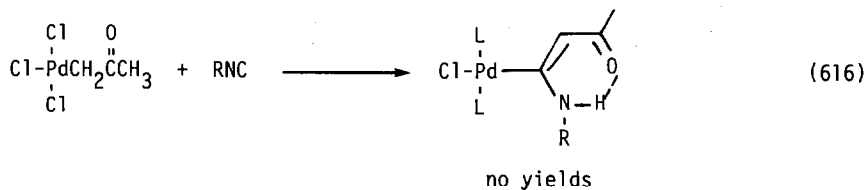
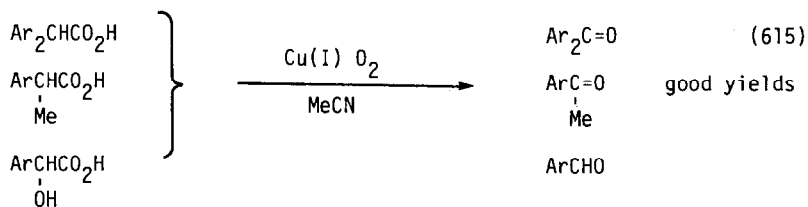
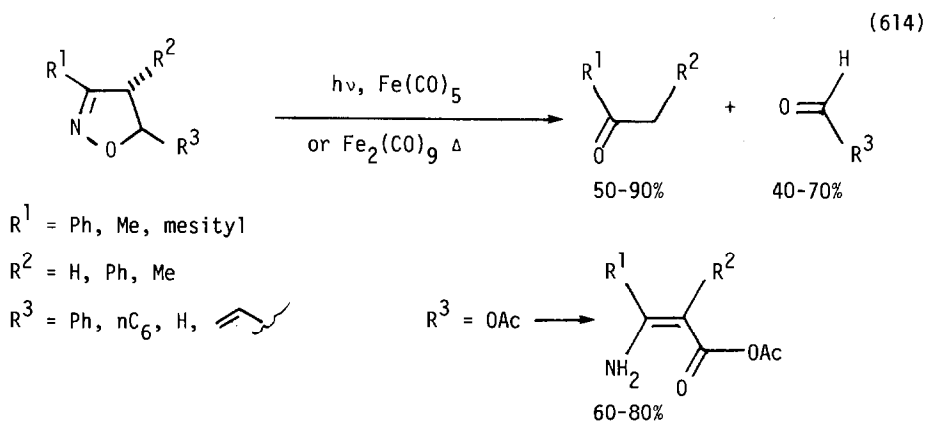

Oximes were converted to ketones by treatment with  $\text{Fe}_2(\text{CO})_9$  (equation 617) [784]. Copper(II) chloride promoted the hydrolysis of tosylhydrazones and acetates back to the carbonyl compounds [785]. Clay-supported  $\text{Fe}(\text{NO}_3)_3$  converted dimethylhydrazones back to ketones in good yield [786]. The same reagent converted dithioketals to ketones (equation 618) [787].

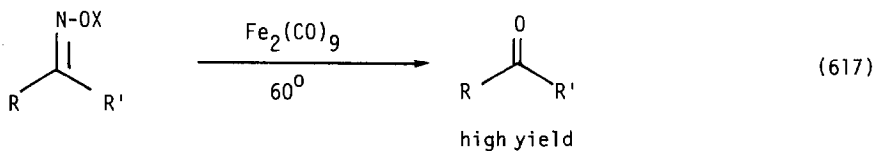

X = Ac, H, Me; R's - Ph, Me, Bz, Ph

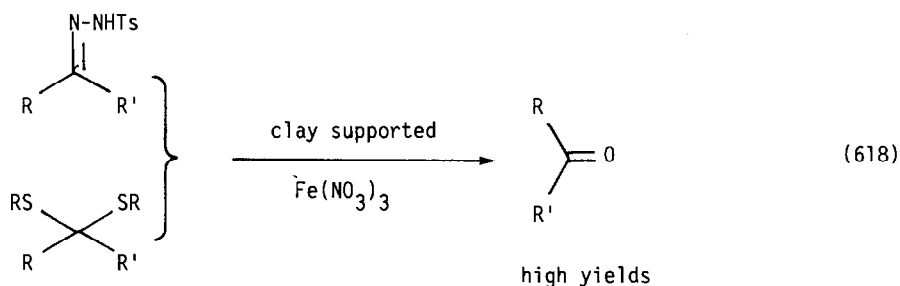

Amberlyst-supported  $\text{HFe}(\text{CO})_4^-$  reduced acid halides to aldehydes in 50-90% yield [788]. The complex  $\text{HCr}(\text{CO})_5^-$  did the same [789].

#### H. Organosilanes

The effect of ligands on nickel(II) complexes on the activity and selectivity of hydrosilation of olefins has been reviewed (6 references) [790]. Nickel(II) phosphine complexes catalyzed the reaction of alkyl Grignard reagents with silanes to give allylsilanes (equation 619) [791]. The complex  $(\text{C}_5\text{Me}_5\text{Rh})_2\text{Cl}_4$  catalyzed the direct production of alkenyl (triethyl)silanes from olefins and triethylsilane [792]. A series of 37 chiral N-chelating ligands with a "lateral chiral center" was made from chiral amines or amino acids, and platinum or rhodium complexes of these were used to catalyze the hydrosilation of acetophenone, methyl benzyl ketone and methyl t-butyl ketone [793]. A rhodium carbene complex catalyzed the hydrosilation of ketones (equation 620) and alkynes [794]. Rhodium(I) complexes catalyzed the hydrosilation of oximes to N-silylamines (equation 621) [795]. With (-)DIOP as ligands up to 19% ee was observed. Palladium(0) or rhodium(I) complexes catalyzed the conversion of allyl acetates to allylsilanes (equation 622) [796].

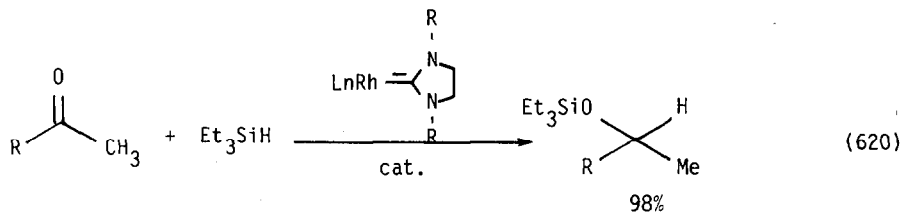
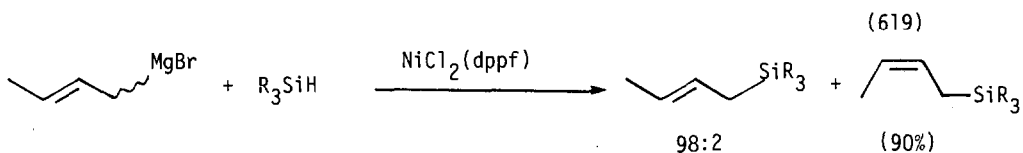

R = Ph, nPr

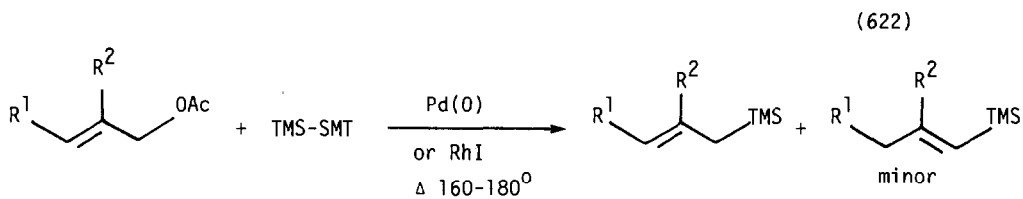
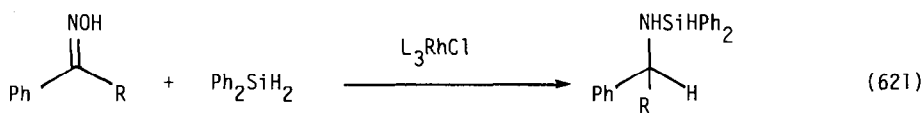

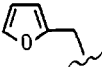
R<sup>1</sup> = H, Ph; R<sup>2</sup> = H, Me, 

### I. Miscellaneous

Allenes were bis stannylated by Me<sub>6</sub>Sn<sub>2</sub> in the presence of palladium(0) catalysts (equation 623) [797]. Aryl halides were converted to aryl stannanes by a similar reaction (equation 624) [798]. Alkynes were converted to vinylstannanes using copper(I) or palladium(0) catalysts (equation 625) [799]. Vinyl germanes were made in a similar way (equation 626) [800]. Allyl acetates were converted to phosphonium salts under palladium(0) catalysts (equation 627) [801].

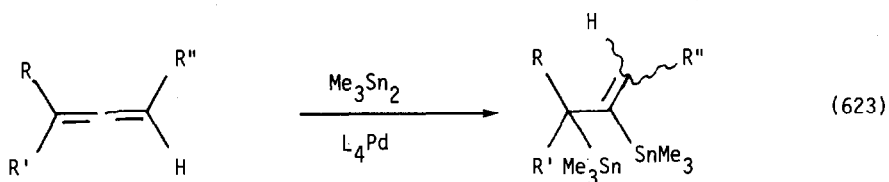

R = H, Ph, MeO, Me<sub>3</sub>Sn, Me

R' = H, Me; R'' = H, Me

40-90%

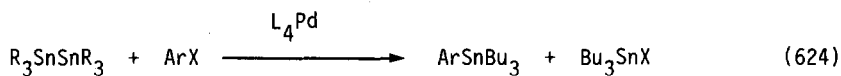

Ar = 4NO<sub>2</sub>Ph, 30%; 3NO<sub>2</sub>Ph, 95%; 2NO<sub>2</sub>Ph, 100%; 4AcPh, 83%; 4CNPh, 85%

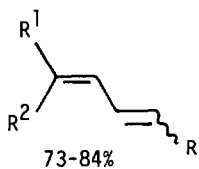
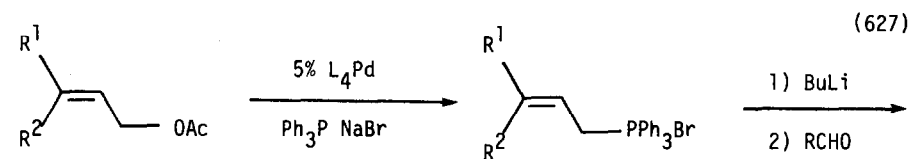
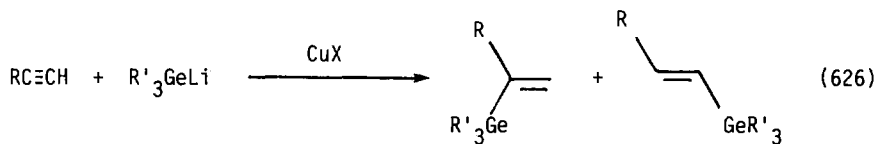
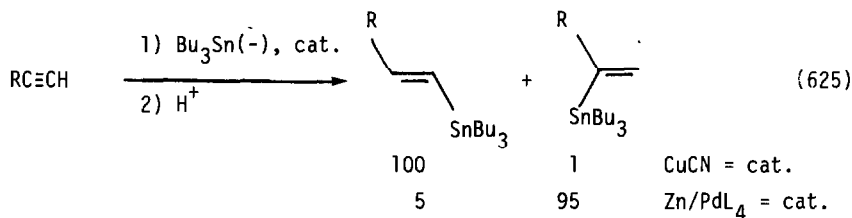

Olefins were oxidized to nitroolefins by palladium(II)/nitro complexes (equation 628) [802]. Olefins were converted to oximes by NO in the presence of a cobalt catalyst (equation 629) [803]. Copper(II) salts catalyzed the process shown in equation 630 [804]. Metal complexes and N-nitrosation reactions have been reviewed (63 references) [805]. Amines were oxidized to nitrones by hydrogen peroxide with tungstate catalysts (equation 631) [806]. Cobalt salts catalyzed the synthesis of phenylformylhydroxamic acid from nitrosobenzene and formalalae [807].

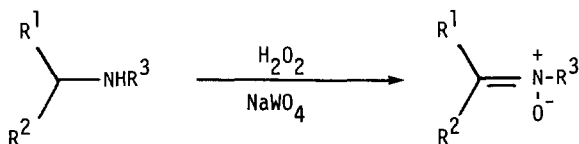
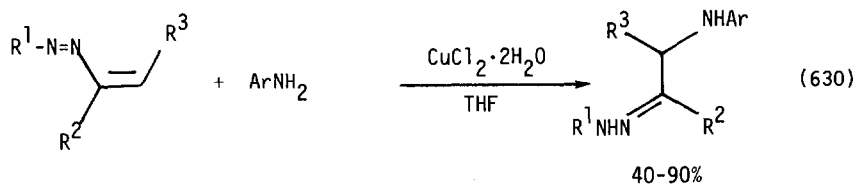
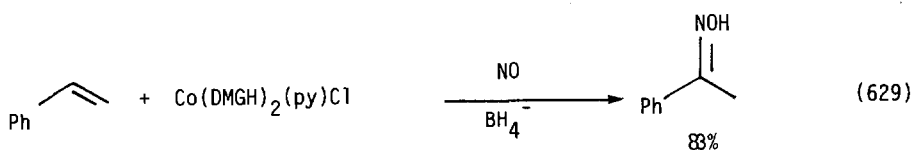
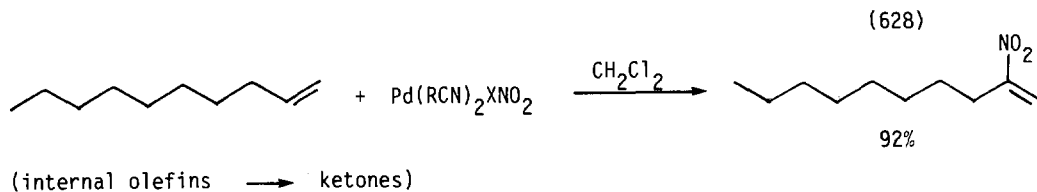

$\text{R}^1 = \text{nPr, Me, Ph}$

$\text{R}^2 = \text{H, Me}$

$\text{R}^3 = \text{nBu, iPr, PhCH}_2$

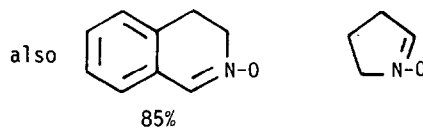

Aryl amines were converted to aryl methyl sulfides by reaction with nitrous acid in the presence of CuMeS [808]. Thioenol ethers were reduced to thiols by triethylsilane and titanium(IV) chloride (equation 632) [809]. Nitroaromatics were reduced to anilines with concomitant disulfide formation by iron(II) lipamide catalysts [810]. Thioethers were oxidized to sulfoxides in up to 91% ee using Sharpless oxidation conditions ( $t\text{BuOOH}/\text{Ti}(\text{O}i\text{Pr})_4/(\text{+})\text{Diethyltartrate}$ ) [811]. Gold(III) catalyzed the oxidation of sulfides to sulfoxides by nitric acid [812]. Allyl and vinyl sulfides were reduced to alkenes by  $\text{Rh}(\text{H})(\text{PPh}_3)_4$  [813]. Palladium on graphite catalyzed a variety of allyl sulfones (equation 633) [814]. Ruthenium(III) catalyzed the addition of sulfonyl chlorides to olefins (equation 634) [815].

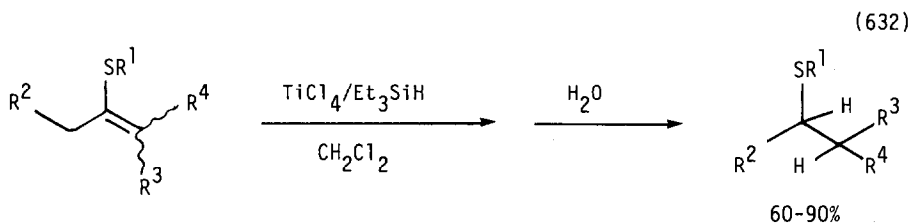

$\text{R}^1 = \text{Ph, Et, Me}$

$\text{R}^2 = \text{Ph, Me, H, } n\text{C}_8$ ;  $\text{R}^3 = \text{H, Ph-CH}_2\text{-CH}_2\text{-CH}_2\text{-}$ ,  $\text{Et, } n\text{C}_6$ ,  $\text{Me}$

$\text{R}^4 = \text{Me}$

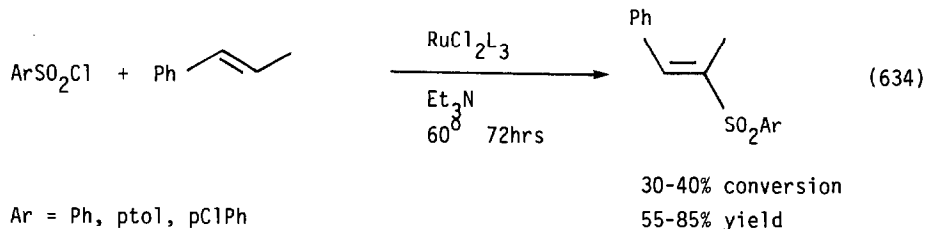
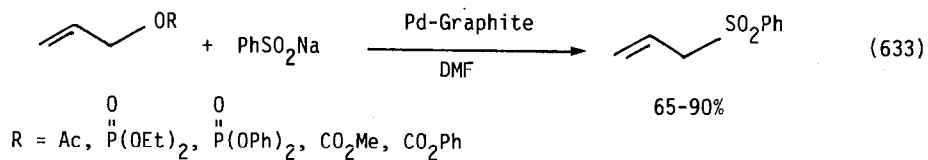

## IV. Reviews

The following reviews have appeared.

- Effect of metal ions in organic synthesis. (14 references) [816]  
 Novel organic syntheses by ruthenium compounds. (34 references) [817]  
 Controlling metal-catalyzed organic syntheses (part 5) target-oriented system enlargement. (62 references) [818]  
 Organometallics in synthesis. (270 references) [819]  
 Transition metals in organic synthesis. Annual survey covering the year 1982. (748 references) [820]  
 Formation of carbon-carbon bonds via  $\pi$ -complexes of transition metals. (108 references) [821]  
 Controlling metal-catalyzed organic syntheses. Part 4. The systematic replacement of atoms as an experimental strategy. (165 references) [822]  
 Organic synthesis through homogeneous catalytic reactions. (48 references) [823]  
 Formation of carbon-carbon bonds catalyzed by vitamin B<sub>12</sub>. (22 references) [824]  
 Organometallic chemistry - a science overlapping inorganic chemistry and organic chemistry. (no references) [825]  
 Organometallic compounds: synthesis, structure, and theory. [826]  
 Surface organometallic chemistry: a new approach to heterogeneous catalysis? (22 references) [827]  
 Organometallic compounds in the preparation of supported catalysts. (85 references) [828]  
 Some aspects of the chemistry of alkyl and hydride derivatives of permethylscandocene. (14 references) [829]  
 Oxidative addition of soluble iridium and rhodium complexes to carbon-hydrogen bonds in methane and higher alkanes. (17 references) [830]  
 Reactive intermediates in organotransition metal chemistry. (46 references) [831]  
 Mechanistic and synthetic aspects of organometallic oxidative additions. (34 references) [832]  
 New developments in the organometallic chemistry of the group IV-V (transition metals). (35 references) [833]  
 Preparation of heteronuclear bridging methylene complexes. (12 references) [834]  
 Reactive organometallic compounds from metallocenes. (39 references) [835]  
 Organic chemistry of polynuclear metal centres. (15 references) [836]  
 Organocopper reagents for the synthesis of saturated, and  $\alpha,\beta$ -ethylenic aldehydes and ketones. (30 references) [837]  
 Homogeneous asymmetric catalysis by means of chiral rhodium complexes. (45 references) [838]  
 Activation of dihydrogen and methane by photoexcited manganese and iron atoms in low temperature matrices. (28 references) [839]  
 Transformation of organoiron complexes of synthetic and chemical interest. (9 reference) [840]

- Transition metals in organic synthesis: hydroformylation, reduction, and oxidation  
Annual Survey, 1982. (494 references) [841]
- Reactivity of coordinated hydrocarbons. (56 references) [842]
- Homogeneous catalysis of oxidation reactions using phosphine complexes. (148  
references) [843]
- Synthetic applications of [propargylium]dicobalt hexacarbonyl complexes. [844]
- Photochemistry of alkyltransition-metal complexes. (218 references) [845]
- $2_8 + 2_8$  Reactions at transition metals. [846]
- Catalysis by complexes with a palladium-palladium bond. [847]
- Organometallic chemistry of rhodium and iridium. [848]
- Activation of catalysts using hydrogen peroxide. Reactions using molybdenum  
peroxide. (46 references) [849]
- Organolanthanide compounds. (225 references) [850]
- Structural consequences of bonding in transition metals carbene complexes. (37  
references) [851]
- Platinum carbonyls and their use in homogeneous catalysis. (288 references) [852]
- The mechanism of the decomposition of organometallic compounds of transition  
metals and the role of intermediate species in catalysis. (108 references)  
[853]
- Reactions of hydroperoxides with amines and aminoalcohols in the presence and  
absence of metal ions. (57 references) [854]
- The splitting of the silicon-carbon bond by compounds of platinum and palladium.  
(101 references) [855]
- The organic chemistry of dinitrogen. (36 references) [856]
- Synthesis and investigation of iron-alkenyl complexes. [857]
- $\mu(\alpha,\omega)$ -Alkanediyl complexes of transition metals. (51 references) [858]
- Alkylcobalt tetracarbonyls and their derivatives. (165 references) [859]
- Houben-Weyl methods of organic chemistry, Vol. 13, Pt. 9B: organometallic compounds  
of cobalt, rhodium, iridium, nickel, palladium, 4th ed. [860]
- Molybdenum atoms in synthesis. [861]
- Application of ultrafine metal particles to organic synthesis. (51 references)  
[862]
- Alkynes and metal atoms. (85 references) [863]
- Oxidations in the homogeneous phase catalyzed by transition metals recent evolu-  
tions. (166 references) [864]
- The role of transition metal salts in one electron transfer organic reactions.  
(36 references) [865]
- Organometallic butatriene chemistry. [866]
- Dienes and their  $\pi$  complexes. [867]



- Methods of organometallic chemistry: organoiron compounds: ferrocene. [868]
- Asymmetric catalysis. (8 references) [869]
- Rules governing asymmetric synthesis with organotransition metals. [870]
- Asymmetric cyclopalladation as a tool of enantioselective synthesis. (30 references) [871]
- DIOP as a ligand in asymmetric catalysis using transition metal phosphine complexes. (60 references) [872]
- Homogeneously catalyzed regiospecific hydrogen transfer from secondary alcohols to polynuclear aromatic hydrocarbons. [873]
- The catalytic activity of some rhodium(I) compounds. (38 references) [874]
- Transition metal hydrides in homogeneous catalytic hydrogenation. (27 references) [875]
- The cis-alkyl and cis-acylrhodium and iridium hydrides. Model intermediates in homogeneous catalysis. (38 references) [876]
- Preparation and properties of Raney nickel-cobalt catalysts. [877]
- Homogeneous catalysis by transition metal complexes. (no references) [878]
- Homogeneous-phase oxidations catalyzed by transition metals: recent advances. (200 references) [879]
- Palladium(II)-assisted reactions of monoolefins. (74 references) [880]
- Transmetallation. (13 references) [881]
- Metal enolate mediated aldol reactions. (35 references) [882]
- Metal enolates in organic synthesis. (28 references) [883]
- Catalysis by transition metal sulfides. (16 references) [884]
- Gel-immobilized metal-complex catalysts. [885]
- Catalysis of transition metal complexes under phase transfer conditions. (58 references) [886]
- New Synthesis chemistry of transition-metal trialkyl silane complexes. (43 references) [887]
- Homogeneous catalysis: a wedding of theory and experiment. The Eugene J. Houdry Award Address. (20 references) [888]
- Reactions of alkyltitanium compounds. (20 references) [889]
- Reduction of phenylthiomethylcarbonyl benzoate esters to alkenes with titanium metal. Cyclopentenone synthesis via the alkylating agent 1-(chloromethyl)-ethenyl diethyl phosphate. [890]

## REFERENCES

1. F. Naso, G. Marchese, Chem. Halides, Pseudo-Halides Azides, 2, 1353 (1983).
2. Q. Feng, Huaxue Tongbao, 1 (1983).
3. D. S. Dhanoa, Diss. Abstr. Int. B, 45, 866 (1984).
4. J. Lindley, Tetrahedron, 40, 1433 (1984).
5. G. W. Ebert, R. D. Rieke, J. Org. Chem., 49, 5282 (1984).
6. B. H. Lipschutz, J. A. Kozlouski, R. S. Wilhelm, J. Org. Chem., 49, 3943 (1984).
7. B. H. Lipschutz, R. S. Wilhelm, J. A. Kozlouski, D. Parker, J. Org. Chem., 49, 3928 (1984).
8. W. R. Bowman, H. Heaney, P. H. G. Smith, Tetrahedron Lett., 25, 5821 (1984).
9. C. Galli, J. F. Bunnett, J. Org. Chem., 49, 3041 (1984).
10. J-i. Setsune, T. Ueda, K. Matsukawa, T. Katao, Chem. Lett., 1931 (1984).
11. P. D. Edwards, A. I. Meyers, Tetrahedron Lett., 25, 939 (1984).
12. R. T. Hrubiec, M. B. Smith, J. Org. Chem., 49, 385 (1984).
13. R. T. Hrubiec, M. B. Smith, Tetrahedron, 40, 1457 (1984).
14. J. A. Bajgrowicz, E. El Hallaoui, R. Jacquier, C. Pigiere, P. Viallefont, Tetrahedron Lett., 25, 2231 (1984).
15. J. A. Bajgrowicz, E. El Hallaoui, R. Jacquier, C. Pigiere, P. Viallefont, Tetrahedron Lett., 25, 2759 (1984).
16. E. J. Corey, N. W. Boaz, Tetrahedron Lett., 25, 3059 (1984).
17. C. J. Elsevier, H. H. Mooiweer, H. Kleijn, P. Vermeer, Tetrahedron Lett., 25, 5571 (1984).
18. J. C. Stowell, B. T. King, Synthesis, 278 (1984).
19. E. Erdik, Tetrahedron, 40, 641 (1984).
20. K. C. Eapen, S. S. Dua, C. Tamborski, J. Org. Chem., 49, 478 (1984).
21. G. S. Reddy, W. Tam, Organometallics, 3, 630 (1984).
22. L. N. Pridgen, Synthesis, 1047 (1984).
23. M. H. Leftin, Diss. Abstr. Int. B, 45, 561 (1984).
24. T. Hayashi, M. Konishi, Y. Kobori, M. Kumada, T. Higuchi, K. Hirotsu, J. Amer. Chem. Soc., 106, 158 (1984).
25. M. Lemaire, J. Buter, B. K. Vriesema, R. McKellogg, J. Chem. Soc., Chem. Comm., 309 (1984).
26. R. Cloux, M. Schlosser, Helv. Chim. Acta, 67, 1470 (1984).
27. P. Kocienski, C. Yeates, J. Chem. Soc., Chem. Comm., 151 (1984).
28. C. Brockway, P. Kocienski, C. Pant, J. Chem. Soc., Perkin Trans. 1, 875 (1984).
29. M. Ishikura, M. Kamada, M. Terashima, Heterocycles, 22, 265 (1984).
30. M. Ishikara, M. Kamada, M. Terashima, Synthesis, 936 (1984).
31. R. B. Miller, S. Dugar, Organometallics, 3, 1261 (1984).

32. H. C. Brown, V. Somayaji, *Synthesis*, 919 (1984).
33. M. Hoshi, Y. Masuda, Y. Nunokawa, A. Arase, *Chem. Lett.*, 1029 (1984).
34. S. Gronowitz, V. Bobosik, K. Lawitz, *Chem. Scr.*, 23, 120 (1984).
35. S. Gronowitz, K. Lawitz, *Chem. Scr.*, 22, 265 (1983).
36. Y. Xu, J. Zhang, *Synthesis*, 778 (1984).
37. Y. Xu, J. Zhang, *Synthesis*, 781 (1984).
38. M. Kosugi, T. Sumiya, T. Ogata, H. Sano, T. Migita, *Chem. Lett.*, 1225 (1984).
39. M. Kosugi, M. Ishiguro, Y. Negishi, H. Sano, T. Migita, *Chem. Lett.*, 1511 (1984).
40. M. Kosugi, I. Takano, M. Sakurai, H. Sano, T. Migita, *Chem. Lett.*, 1221 (1984).
41. M. Kosugi, I. Hagihara, T. Sumiya, T. Migita, *Bull. Chem. Soc. Jpn.*, 57, 242 (1984).
42. F. K. Sheffy, J. P. Godschalx, J. K. Stille, *J. Amer. Chem. Soc.*, 106, 4833 (1984).
43. J. P. Godschalx, *Diss. Abstr. Int. B.*, 44, 1118 (1983).
44. V. Ratovelomanana, G. Linstrumelle, *Synth. Comm.*, 14, 179 (1984).
45. E-i. Negishi, N. Okukado, S. F. Lovich, F-t. Luo, *J. Org. Chem.*, 49, 2629 (1984).
46. P. Vincent, J. P. Beaucourt, L. Pichat, *Tetrahedron Lett.*, 25, 201 (1984).
47. M. Uno, K. Seto, S. Takahashi, *J. Chem. Soc., Chem. Comm.*, 932 (1984).
48. J. R. Luly, H. Rapoport, *J. Org. Chem.*, 49, 1671 (1984).
49. D. E. Ames, A. Opalko, *Tetrahedron*, 40, 1919 (1984).
50. S. J. Tremont, H. U. Rahman, *J. Amer. Chem. Soc.*, 106, 5759 (1984).
51. K. Sanechika, T. Yamamoto, A. Yamamoto, *Bull. Chem. Soc. Jpn.*, 57, 752 (1984).
52. N. A. Bumagin, A. B. Ponomaryov, I. P. Beletskaya, *Synthesis*, 728 (1984).
53. A. Carpita, A. Lessi, R. Rossi, *Synthesis*, 571 (1984).
54. D. Villemain, P. Cadiot, M. Kuetegan, *Synthesis*, 230 (1984).
55. G. C. Nwokogu, *Tetrahedron Lett.*, 25, 3263 (1984).
56. C. Germon, A. Alexakis, J. F. Normant, *Synthesis*, 40 (1984).
57. C. Germon, A. Alexakis, J. F. Normant, *Synthesis*, 43 (1984).
58. M. Gardette, N. Jabri, A. Alexakis, J. F. Normant, *Tetrahedron*, 40, 2741 (1984).
59. L. D. Boardman, V. Bagheri, H. Sawda, E-i. Negishi, *J. Amer. Chem. Soc.*, 106, 6105 (1984).
60. S. Al-Jibori, B. L. Shaw, *Inorg. Chim. Acta*, 74, 235 (1983).
61. G. Friour, G. Cahiez, J. F. Normant, *Synthesis*, 37 (1984).
62. G. Friour, A. Alexakis, G. Cahiez, J. Normant, *Tetrahedron*, 40, 683 (1984).
63. V. Fiandanese, G. Marcheier, V. Martina, L. Ronzini, *Tetrahedron Lett.*, 29, 4805 (1984).

64. R. A. Greg, J. Org. Chem., **49**, 2288 (1984).
65. J. W. Labadie, Diss. Abstr. Int. B., **44**, 1121 (1983).
66. S-i. Inaba, R. D. Rieke, Chem. Lett., 25 (1984).
67. T. Ishihara, T. Maekawa, T. Ando, Tetrahedron Lett., **25**, 1377 (1984).
68. M. Basato, B. Corain, M. Cofler, A. C. Veronese, G. Zanatti, J. Chem. Soc., Chem. Comm., 1593 (1984).
69. S. Wu, C. Zhao, Y. Zhou, R. Hu, Lanzhou Daxu Zuebao Ziran Kexueban, **19**, 206 (1983).
70. L. S. Hegedus, Tetrahedron, **40**, 2415 (1984).
71. L. A. P. Kane-Maguire, E. D. Honig, D. A. Sweigart, Chem. Rev., **84**, 525 (1984).
72. J. V. N. V. Prasad, C. N. Pillai, J. Organomet. Chem., **259**, 1 (1983).
73. T. Kamiyama, S. Enomoto, Shokubai, **26**, 22 (1984).
74. T. Jeffery, J. Chem. Soc., Chem. Comm., 1287 (1984).
75. J. B. Davison, N. M. Simon, S. A. Sojka, J. Mol. Catal., **22**, 349 (1984).
76. A. Spencer, J. Organometal. Chem., **265**, 323 (1984).
77. S. Cacchi, F. LaTorre, G. Palmieri, J. Organomet. Chem., **268**, C48 (1984).
78. S. Cacchi, G. Palmieri, Synthesis, 575 (1984).
79. S. Cacchi, E. Morera, G. Ortar, Tetrahedron Lett., **25**, 2271 (1984).
80. A. Spencer, J. Organomet. Chem., **270**, 115 (1984).
81. T-a. Mitsudo, W. Fischetti, R. F. Heck, J. Org. Chem., **49**, 1640 (1984).
82. J. I. Kim, Taehan Hwahakhoe Chi, **27**, 441 (1983).
83. J. T. Lee, J. I. Kim, Taehan Hwahakhoe Chi, **28**, 335 (1984).
84. P. J. Harrington, L. S. Hegedus, J. Org. Chem., **49**, 2657 (1984).
85. M. Catellani, G. P. Chiusoli, A. Mari, J. Organomet. Chem., **275**, 129 (1984).
86. G. Bocelli, M. Catellani, G. P. Chiusoli, S. Larocca, J. Organomet. Chem., **265**, C9 (1984).
87. R. Grigg, P. Stevenson, T. Worakun, J.C.S. Chem. Comm., 1073 (1984).
88. M. Ahmar, B. Cazes, J. Gore, Tetrahedron Lett., **25**, 4505 (1984).
89. I. Shimizu, J. Tsuji, Chem. Lett., 233 (1984).
90. J. Tsuji, H. Nagashime, Tetrahedron, **40**, 2699 (1984).
91. T. Itahara, K. Kawasaki, F. Ouseito, Synthesis, 236 (1984).
92. Y. Murakami, Y. Yokoyama, T. Aoki, Heterocycles, **22**, 1493 (1984).
93. T. Itahara, F. Ouseito, Synthesis, 488 (1984).
94. T. Itahara, K. Kawasaki, F. Ouseito, Bull. Chem. Soc. Jpn., **57**, 3488 (1984).
95. K. Kikukawa, K. Ikenaga, K. Kono, K. Toritani, F. Wada, T. Matsuda, J. Organomet. Chem., **270**, 273 (1984).
96. K. Kikukawa, K. Ikenaga, F. Wada, T. Matsuda, Tetrahedron Lett., **25**, 5789 (1984).

97. R. C. Larock, C. L. Liu, H. H. Law, S. Varaprath, Tetrahedron Lett., **25**, 4459 (1984).
98. R. C. Larock, S. Varaprath, H. H. Lau, C. A. Fellows, J. Amer. Chem. Soc., **106**, 5274 (1984).
99. R. C. Larock, L. W. Harrison, M. H. Hsu, J. Org. Chem., **49**, 3665 (1984).
100. R. C. Larock, S. Varaprath, J. Org. Chem., **49**, 3432 (1984).
101. R. C. Larock, K. Takagi, J. Org. Chem., **49**, 2701 (1984).
102. A. D. Ryabov, V. A. Polyakov, A. K. Yatsimirskii, Inorg. Chim. Acta., **91**, 59 (1984).
103. V. V. Dunina, O. A. Zalevskaya, V. M. Potapov, Zh. Obshch. Khim., **54**, 455 (1984).
104. A. D. Ryabov, A. K. Yatsimirskii, Inorg. Chem., **23**, 789 (1984).
105. V. I. Sokolov, N. S. Khrushcheva, L. L. Troitskaya, O. A. Reutov, Dokl. Adak. Nauk SSSR, **274**, 342 (1984).
106. A. D. Ryabov, I. K. Sakodinskaya, A. K. Yatsimirsky, J. Chem. Soc., Perkin Trans. 2, 1511 (1983).
107. J. A. Kampmeier, S. H. Harris, I. Mergelsberg, J. Org. Chem., **49**, 621 (1984).
108. C. K. Tseng, E. G. Teach, R. W. Simons, Synth. Comm., **14**, 1027 (1984).
109. A. Alexakis, J. F. Normant, Israel J. Chem., **24**, 113 (1984).
110. Y. Morizawa, H. Oda, K. Oshima, H. Nozaki, Tetrahedron Lett., **25**, 1163 (1984).
111. M. Rosenblum, A. Bucheister, T. C. T. Chang, M. Cohen, M. Marsi, S. B. Samuels, D. Scheck, N. Sofen, J. C. Watkins, Pure Appl. Chem., **56**, 129 (1984).
112. R. Baker, R. Keen, M. D. Morris, R. W. Turner, J.C.S. Chem. Comm., 987 (1984).
113. T. C. T. Chang, M. Rosenblum, Israel J. Chem., **24**, 99 (1984).
114. M. Marsi, M. Rosenblum, J. Am. Chem. Soc., **106**, 7264 (1984).
115. M. P. Doyle, L. C. Wang, K-L. Loh, Tetrahedron Lett., **25**, 4087 (1984).
116. M. P. Doyle, R. L. Dorow, W. E. Buhro, J. H. Griffin, W. H. Tamblin, M. L. Trudell, Organometallics, **3**, 44 (1984).
117. M. P. Doyle, J. H. Griffin, V. Bagheri, R. L. Dorow, Organometallics, **3**, 53 (1984).
118. D. J. Milner, J. Organomet. Chem., **262**, 85 (1984).
119. M. P. Doyle, J. H. Griffin, M. S. Chinn, D. van Leusen, J. Org. Chem., **49**, 1917 (1984).
120. A. Demonceau, A. F. Noels, A. J. Hubert, P. Teyssie, Bull. Chem. Soc., Belg., **93**, 945 (1984).
121. E. C. Taylor, Haw M. L. Davies, J. Org. Chem., **49**, 113 (1984).
122. M. A. McKervery, S. M. Tuladhar, M. F. Twokig, J.C.S. Chem. Comm., 129 (1984).

123. A. K. Chakroborti, J. K. Ray, K. K. Kundu, S. Chakoabarty, D. Mukherjee, U. R. Ghatak, J.C.S. Perkin I, 261 (1984).
124. P. Callant, L. D'Haeneus, M. Vandewalle, Synth. Comm., 14, 155 (1984).
125. S. A. Matlin, W. J. Lough, L. Chan, D. M. H. Abram, Z. Zhou, J.C.S. Chem. Comm., 1038 (1984).
126. D. A. Laidler, D. J. Milner, J. Organomet. Chem., 270, 121 (1984).
127. H. Brunner, W. Miehl, Monat. Fur. Chem., 115, 1237 (1984).
128. A. Demonceau, A. F. Noels, A. J. Anciaux, A. J. Hubert, P. Teyssie, Bull. Chem. Soc., Belg., 93, 949 (1984).
129. O. M. Nefedov, I. E. Dolgii, Yu. V. Tomilov, V. G. Bordakov, Izv. Akad. Nauk SSSR, Ser. Khim., 119 (1984).
130. Yu. V. Tomilov, V. G. Bordakov, I. E. Dolgii, O. M. Nefedov, Izv. Akad. Nauk SSSR, Ser. Khim., 582 (1984).
131. G. V. Pazynina, E. A. Luk'yanets, I. G. Bolesov, Zh. Org. Khim., 20, 802 (1984).
132. G. R. Husk, M. S. Brookhart, Gov. Rep. Announce. Index (U.S.), 84, 110 (1984).
133. C. P. Casey, W. H. Miles, Organometallics, 3, 808 (1984).
134. S. C. H. Ho, D. A. Straus, R. H. Grubbs, J. Am. Chem. Soc., 106, 1533 (1984).
135. M. Calellani, G. P. Chiusoli, J. Organomet. Chem., 275, 257 (1984).
136. C. E. Russell, Diss. Abstr. Int. B, 44, 1125 (1983).
137. S. A. Stanton, Diss. Abstr. Int. B, 45, 199 (1984).
138. J. G. Hamilton, J. Chem. Soc., Faraday Trans 1, 80, 129 (1984).
139. P. Laszlo, J. Lucchetti, Tetrahedron Lett., 25, 2147 (1984).
140. S. Danishefsky, D. F. Harvey, G. Quallich, B. J. Uang, J. Org. Chem., 49, 392 (1984).
141. J. M. Alcaray, F. Mathey, Tetrahedron Lett., 25, 207 (1984).
142. R. Glass, W. W. McConnell, Organometallics, 3, 1630 (1984).
143. M. E. Wright, J. F. Hoover, G. O. Nelson, C. P. Scott, R. S. Glass, J. Org. Chem., 49, 3059 (1984).
144. H. N. C. Wong, Y. D. Xing, Y. F. Zhou, Q. Q. Gong, C. Zhang, Synthesis, 787 (1984).
145. Z. Goldschmidt, S. Antebi, D. Cohen, I. Goldberg, J. Organomet. Chem., 273, 347 (1984).
146. K. Raab, W. Beck, Chem. Ber., 117, 3169 (1984).
147. R. G. Salomon, S. Ghosh, S. W. Raychaudhuri, T. S. Miranti, Tetrahedron Lett., 25, 3167 (1984).
148. K. Avasthi, S. R. Raychandhuri, R. G. Salomon, J. Org. Chem., 49, 4322 (1984).
149. J. A. Miller, E-i. Negishi, Israel J. Chem., 24, 76 (1984).

150. M. Nitta, T. Kobayashi, Tetrahedron Lett., 25, 959 (1984).
151. E. Uhlig, B. Hipler, Tetrahedron Lett., 25, 5871 (1984).
152. D. Stephen, A. Gorgues, A. LeCoq, Tetrahedron Lett., 25, 5649 (1984).
153. H. Hoberg, K. Summermann, J. Organomet. Chem., 264, 379 (1984).
154. H. Hoberg, K. Summermann, J. Organomet. Chem., 275, 239 (1984).
155. I. Shimizu, Y. Ohashi, J. Tsuji, Tetrahedron Lett., 25, 5183 (1984).
156. H. Westmijze, H. Kleijn, P. Vermeer, J. Organomet. Chem., 276, 317 (1984).
157. F. Ziegler, K. Mikami, Tetrahedron Lett., 25, 131 (1984).
158. R. S. E. Conn, M. Karras, B. B. Snider, Israel J. Chem., 24, 108 (1984).
159. A. Alexakis, A. Commercon, C. Coulentianos, J. F. Normant, Tetrahedron, 40, 715 (1984).
160. N. A. Bumagin, A. B. Ponomarev, I. P. Beletskaya, Izv. Akad. Nauk SSSR, Ser. Khim., 1561 (1984).
161. S. Cacchi, M. Felici, B. Pietroni, Tetrahedron Lett., 25, 3137 (1984).
162. R. Rossi, A. Carpita, A. Lezzi, Tetrahedron, 40, 2773 (1984).
163. J. A. Miller, E-i. Negishi, Tetrahedron Lett., 25, 5863 (1984).
164. D. L. Reger, K. A. Belmore, E. Mintz, P. J. McElligot, Organomet., 3, 135 (1984).
165. T. Fuchikami, I. Ojima, Tetrahedron Lett., 25, 303 (1984).
166. J. K. Crandall, W. J. Michaely, J. Org. Chem., 49, 4744 (1984).
167. S. L. Baysdon, Diss. Abstr. Int. B, 45, 185 (1984).
168. L. S. Liebeskind, J. P. Leeds, S. L. Baysdon, S. Iyer, J. Am. Chem. Soc., 106, 6451 (1984).
169. M. S. South, L. S. Liebeskind, J. Am. Chem. Soc., 106, 4181 (1984).
170. M. N. Saha, Isr. J. Chem., 24, 105 (1984).
171. F. W. Schultz, G. S. Ferguson, D. W. Thompson, J. Org. Chem., 49, 1736 (1984).
172. H. L. Goering, S. M. Kantner, J. Org. Chem., 49, 422 (1984).
173. R. W. Richards, H. Rönnerberg, J. Org. Chem., 49, 573 (1984).
174. T. Fujisawa, K. Umezumi, M. Kawashima, Chem. Lett., 1795 (1984).
175. T. Ibuka, G-Nang Chu, F. Yoneda, Tetrahedron Lett., 25, 3247 (1984).
176. C. V. Srinivasan, Diss. Abstr. Int. B, 44, 3087 (1984).
177. A. Chrili, A. Alexakis, J. F. Normant, Tetrahedron Lett., 25, 3079 (1984).
178. N. Ono, I. Hamamoto, A. Kaji, J. C. S. Chem. Comm., 274 (1984).
179. J. P. Marino, R. Fernandez de la Pradilla, E. Laborde, J. Org. Chem., 49, 5279 (1984).
180. K. Ruitenberg, P. Vermeer, Tetrahedron Lett., 25, 3019 (1984).
181. A. Alexakis, A. Commercon, C. Coulentianos, J. F. Normant, Pure Appl. Chem., 55, 1759 (1983).

182. U. M. Dzhemilev, A. G. Ibragimov, R. A. Saraev, D. L. Minsker, Izv. Akad. Nauk SSSR, Ser. Khim., 907 (1984).
183. H. Sugimura, H. Takei, Chem. Lett., 1505 (1984).
184. S. Araki, Y. Butsugan, J. Chem. Soc., Perkin Trans. 1, 969 (1984).
185. D. L. Minsker, A. G. Ibragimov, U. M. Dzhemilev, Zh. Org. Khim., 20, 959 (1984).
186. B. M. Trost, Fundam. Res. Homogeneous Catal., 4, 117 (1984).
187. M. Kumada, T. Hayashi, Kagaku (Kyoto), 38, 815 (1983).
188. J. Tsuji, Sel., Goal Synth. Effic., Proc. Workshop Conf. Hoechst, 14th, 317 (1984).
189. B. M. Trost, M-H. Hung, J. Am. Chem. Soc., 106, 6837 (1984).
190. B. Akermark, S. Hansson, B. Krakenberger, A. Vitagliano, K. Zetterberg, Organometallics, 3, 679 (1984).
191. B. M. Trost, M. Lautens, M-H. Hung, C. S. Carmichael, J. Am. Chem. Soc., 106, 7641 (1984).
192. S. A. Godleski, E. B. Villhauer, J. Org. Chem., 49, 2246 (1984).
193. E. Keinan, M. Sahai, J. C. S. Chem. Comm., 648 (1984).
194. X. Lu, Y. Huang, J. Organomet. Chem., 268, 185 (1984).
195. P. F. Schuda, B. Bernstein, Syn. Comm., 14, 293 (1984).
196. J. Tsuji, K. Takahashi, I. Minami, I. Shimizu, Tetrahedron Lett., 25, 4783 (1984).
197. B. M. Trost, C. R. Self, J. Org. Chem., 49, 468 (1984).
198. D. Djahabini, B. Cazes, J. Gore, Tetrahedron Lett., 25, 203 (1984).
199. K. Yamamoto, R. Deguchi, Y. Ogimura, J. Tsuji, Chem. Lett., 1657 (1984).
200. T. Takahashi, Y. Jinbo, K. Kitamura, J. Tsuji, Tetrahedron Lett., 25, 5921 (1984).
201. T. Takahashi, A. Ootake, J. Tsuji, Tetrahedron Lett., 25, 1921 (1984).
202. Y. Inoue, M. Toyofuku, H. Hashimoto, Chem. Lett., 1227 (1984).
203. K. Hiroi, R. Kitayama, S. Sato, Chem. Lett., 929 (1984).
204. K. Hiroi, R. Kitayama, S. Sato, J. C. S. Chem. Comm., 303 (1984).
205. B. M. Trost, J. W. Herndon, J. Am. Chem. Soc., 106, 6835 (1984).
206. J. P. Genet, D. Ferroud, Tetrahedron Lett., 25, 3579 (1984).
207. S. Torii, H. Tanaka, T. Katoh, K. Morisaki, Tetrahedron Lett., 25, 3207 (1984).
208. W. E. VanArsdale, Diss. Abstr. Int. B, 44, 3412 (1984).
209. N. Miyaura, H. Suginome, A. Suzuki, Tetrahedron Lett., 25, 761 (1984).
210. J. Tsuji, I. Minami, I. Shimizu, Tetrahedron Lett., 25, 5157 (1984).
211. W. Smadja, G. Ville, G. Cahiez, Tetrahedron Lett., 25, 1793 (1984).
212. T. Fuchikami, I. Ojima, Tetrahedron Lett., 25, 307 (1984).
213. M. Saha, K. M. Nicholas, J. Org. Chem., 49, 418 (1984).
214. G. S. Mikaelyan, A. S. Gybin, V. A. Smit, Izv. Akad. Nauk SSSR, Ser. Khim., 468 (1984).



215. M. Saha, K. M. Nicholas, Israel J. Chem., 24, 105 (1984).
216. M. F. Semmelhack, Sel., Goal Synth. Effic., Proc. Workshop Conf. Hoechst. 14th, 227 (1984).
217. V. I. Koshelev, L. N. Paramonova, M. P. Filippov, Zh. Org. Khim., 20, 1338 (1984).
218. G. Bontempelli, S. Daniele, M. Fiorani, J. Electroanal. Chem. Interfacial Electrochem., 160, 249 (1984).
219. D. L. Coffen, B. Schaer, F. T. Bizzarco, J. B. Cheung, J. Org. Chem., 49, 296 (1984).
220. M. Tiecco, L. Testaferri, M. Tingoli, D. Chianelli, M. Montanucci, Synthesis, 736 (1984).
221. H. B. Abajian, Diss. Abstr. Int. B, 44, 797 (1983).
222. K. Takagi, N. Hayama, K. Sasaki, Bull. Chem. Soc., Jpn., 57, 1887 (1984).
223. S. Miyano, S. Handa, K. Shimizu, K. Tagami, H. Hashimoto, Bull. Chem. Soc., Jpn., 57, 1943 (1984).
224. R. Vanderesse, J. J. Brunet, P. Canbere, J. Organomet. Chem., 264, 263 (1984).
225. S-i. Inaba, R. D. Rieke, Synthesis, 842 (1984).
226. S-i. Inaba, H. Matsumoto, R. D. Rieke, J. Org. Chem., 49, 2093 (1984).
227. D-i. Momose, K. Iguchi, T. Sugiyama, Y. Yamada, Chem. Pharm. Bull., 32, 1840 (1984).
228. K. Takagi, H. Mimura, S. Inokawa, Bull. Chem. Soc., Jpn., 57, 3517 (1984).
229. H. Hagihara, T. Sugioka, H. Uda, Synth. Comm., 14, 1193 (1984).
230. M. Iyoda, M. Sakaitani, T. Miyazaki, M. Oda, Chem. Lett., 2005 (1984).
231. T. Itahara, M. Hashimoto, H. Yumisashi, Synthesis, 255 (1984).
232. H. Guenther, P. Kovacic, Synth. Comm., 14, 413 (1984).
233. P. L. Majumder, M. Joardar, Indian J. Chem., Sect. B, 22B, 1191 (1983).
234. S. Tsuruya, K. Kinumi, K. Hagi, M. Masai, J. Mol. Catal., 22, 47 (1983).
235. R. Grigg, J. F. Malone, T. R. B. Mitchell, A. Ramasubbu, R. M. Scott, J. C. S. Perkin I, 1745 (1984).
236. V. Rautenstrauch, Tetrahedron Lett., 25, 3845 (1984).
237. M. Akita, H. Yasuda, A. Nakamura, Bull. Chem. Soc., Jpn., 57, 480 (1984).
238. T. L. Chen, T. H. Chan, A. Shaver, J. Organomet. Chem., 268, C1 (1984).
239. D. Lenoir, D. Malivitz, B. Meyer, Tetrahedron Lett., 25, 2965 (1984).
240. G. Markl, W. Burger, Angew. Chem. Int. Ed. Engl., 23, 894 (1984).
241. J. Tirado-Rives, M. A. Oliver, F. R. Fronczek, R. D. Gandour, J. Org. Chem., 49, 1627 (1984).
242. M. Petit, A. Mortreux, F. Petit, J. Chem. Soc., Chem. Comm., 341 (1984).
243. L. B. Anderson, F. A. Cotton, D. DeMarco, L. R. Falvello, S. M. Tetrick, R. A. Walton, J. Am. Chem. Soc., 106, 4743 (1984).

244. N. J. Trivedi, Diss. Abstr. Int. B, 44, 3411 (1984).
245. D. E. Smith, Diss. Abstr. Int. B, 44, 3411 (1984).
246. Y. Inoue, J. Yamashita, H. Hashimoto, Synthesis, 244 (1984).
247. M. K. Andari, A. V. Krylov, O. G. Levanda, A. P. Belov, Koord. Khim., 9, 1422 (1983).
248. S. A. Godleski, K. B. Gundlach, H. Y. Ho, E. Keinan, F. Frolow, Organomet., 3, 21 (1984).
249. D. A. Hunt, J. M. Quante, R. L. Tyson, L. W. Dasher, J. Org. Chem., 49, 5262 (1984).
250. A. Gollaszewski, J. Schwartz, J. Am. Chem. Soc., 106, 5028 (1984).
251. R. S. Valpey, Diss. Abstr. Int. B, 44, 1462 (1983).
252. D. Seebach, A. K. Beck, M. Schiess, L. Widler, A. Wonnacott, Pure Appl. Chem., 55, 1807 (1983).
253. H. Takahashi, Hoshi Yakka Daigaku Kiyō, 13 (1983).
254. R. Dams, Diss. Abstr. Int. B, 44, 3403 (1984).
255. T. Ishihara, T. Yamanaka, T. Ando, Chem. Lett., 1165 (1984).
256. M. T. Reetz, S-H. Kyung, J. Westermann, Organometallics, 3, 1716 (1984).
257. M. T. Reetz, M. Sauerwald, J. Org. Chem., 49, 2292 (1984).
258. Y. Kobayashi, K. Umeyama, F. Sato, J. C. S. Chem. Comm., 621 (1984).
259. K. Furuta, Y. Iheda, N. Meguriya, N. Ikeda, H. Yamamoto, Bull. Chem. Soc., Jpn., 57, 2781 (1984).
260. J. Ukai, Y. Ikeda, N. Ikeda, H. Yamamoto, Tetrahedron Lett., 25, 5173, 5177 (1984).
261. F. Sato, H. Kanbara, Y. Tanaka, Tetrahedron Lett., 25, 5063 (1984).
262. K. Furuta, M. Ishiguro, R. Haruta, N. Ikeda, H. Yamamoto, Bull. Chem. Soc., Jpn., 57, 2768 (1984).
263. H. Hiroaka, K. Furuta, N. Ikeda, H. Yamamoto, Bull. Chem. Soc., Jpn., 57, 2777 (1984).
264. Y. Yamada, M. Hirose, K. Watanabe, Utsunomiya Daigaku Kyoikugakubu Kiyō, Dai-2-bu, 32 (1982) CA102867p.
265. D. Seebach, C. Betschart, M. Schiess, Helv. Chim. Acta, 67, 1593 (1984).
266. R. J. Sundberg, J. P. Laurino, J. Org. Chem., 49, 249 (1984).
267. C. Goasdoue, N. Goasdoue, M. Gaudemar, Tetrahedron Lett., 25, 537 (1984).
268. S. D. Lindell, J. D. Elliot, W. S. Johnson, Tetrahedron Lett., 25, 3947 (1984).
269. W. S. Johnson, P. H. Crackett, J. D. Elliot, J. J. Jagodzinski, S. D. Lindell, S. Natarajin, Tetrahedron Lett., 25, 3951 (1984).
270. A. Mori, K. Marwoka, H. Yamamoto, Tetrahedron Lett., 25, 4421 (1984).
271. L. Clawson, S. L. Buchwald, R. H. Grubbs, Tetrahedron Lett., 25, 5733 (1984).
272. C. S. Wilcox, G. W. Long, H. Suh, Tetrahedron Lett., 25, 395 (1984).

273. T. S. Chou, S. B. Huang, W. H. Hsu, J. Chin. Chem. Soc. (Taipei), 30, 277 (1982).
274. S. M. Clift, J. Schwartz, J. Am. Chem. Soc., 106, 8300 (1984).
275. T. Kauffmann, P. Fiegenbaum, R. Wieschollek, Angew. Chem. Int. Ed., 23, 531 (1984).
276. T. Kauffman, G. Kieper, Angew. Chem. Int. Ed., 23, 532 (1984).
277. T. Kauffman, R. Abeln, P. Wingbermukle, Angew. Chem. Int. Ed., 23, 728 (1984).
278. A. Ghribi, A. Alexakis, J. F. Normant, Tetrahedron Lett., 25, 3075 (1984).
279. A. Ghribi, A. Alexakis, J. F. Normant, Tetrahedron Lett., 25, 3083 (1984).
280. M. Wada, Y. Sakurai, K-y. Akiba, Tetrahedron Lett., 25, 1079 (1984).
281. T. Imamoto, T. Takeyama, M. Yokoyama, Tetrahedron Lett., 25, 3225 (1984).
282. G. A. Molander, J. B. Etter, Tetrahedron Lett., 25, 3281 (1984).
283. K. Takai, M. Sato, K. Oshima, H. Nozaki, Bull. Chem. Soc., Jpn., 57, 108 (1984).
284. W. J. Scott, G. T. Crisp, J. K. Stille, J. Am. Chem. Soc., 106, 4636 (1984).
285. T. Hiyama, M. Sawahara, M. Obayashi, Nippon Kagaku Kaishi, 1022 (1984).
286. S-i. Inaba, R. D. Rieke, Synthesis, 844 (1984).
287. N. J. O'Reilly, M. Maruta, N. Ishikawa, Chem. Lett., 517 (1984).
288. P. Breuilles, D. Ughen, Tetrahedron Lett., 25, 5759 (1984).
289. S. G. Davies, J. I. Seeman, Tetrahedron Lett., 25, 1845 (1984).
290. N. Aktogu, H. Felkin, G. J. Baird, S. G. Davies, O. Watts, J. Organomet. Chem., 262, 49 (1984).
291. S. G. Davies, I. M. Dordor, P. Warner, J. Chem. Soc., Chem. Comm., 956 (1984).
292. S. G. Davies, I. M. Dordor, T. C. Walker, P. Warner, Tetrahedron Lett., 25, 2709 (1984).
293. L. S. Liebeskind, M. E. Welker, Tetrahedron Lett., 25, 4341 (1984).
294. A. Lukacs (III), Diss. Abstr. Int. B, 44, 3788 (1984).
295. V. V. Litvak, P. P. Kun, V. D. Shteingarts, Zh. Org. Khim., 20, 753 (1984).
296. P. P. Kun, V. V. Litvak, V. D. Shteingarts, Zh. Org. Khim., 20, 768 (1984).
297. K. Dimroth, R. Thamm, H. Kaletsch, Z. Naturforsch., B: Anorg. Chem., Org. Chem., 39B, 207 (1984).
298. B. Ohlsson, C. Ullenus, J. Organomet. Chem., 267, C34 (1984).
299. T. G. Traylor, K. J. Stewart, M. J. Goldberg, J. Am. Chem. Soc., 106, 4445 (1984).
300. J. J. Harrison, J. Am. Chem. Soc., 106, 1487 (1984).
301. P. J. Beswick, S. J. Leach, N. F. Masters, P. A. Widdowson J. Chem. Soc., Chem. Comm., 46 (1984).
302. G. Jaouen, S. Top, A. Laconi, D. Couturier, J. Brocard, J. Am. Chem. Soc., 106, 2207 (1984).
303. S. Top, A. Vessieres, J. P. Abjean, G. Jaouen, J. Chem. Soc., Chem. Comm., 428 (1984).

304. M. Uemura, T. Minami, Y. Hagashi, J. Chem. Soc. Chem. Comm., 1193 (1984).
305. J. Brocard, A. Laconi, D. Couturier, S. Top, G. Jaouen, J. Chem. Soc., Chem. Comm., 475 (1984).
306. J-F. Halet, J-Y. Saillard, R. Caro, J-Y. LeBihan, S. Top, G. Jaouen, J. Organomet. Chem., 267, C37 (1984).
307. B. Caro, J-Y. LeBihan, J-P. Guillot, S. Top, G. Jaouen, J. Chem. Soc. Chem. Comm., 602 (1984).
308. D. Astruc, Tetrahedron, 39, 4027 (1983).
309. A. M. Madonik, D. Mandon, P. Michaud, C. Lapinte, D. Astrui, J. Am. Chem. Soc., 106, 3381 (1984).
310. M. Brookhart, A. Lukacs, J. Am. Chem. Soc., 106, 4161 (1984).
311. R. G. Sutherland, A. Piorko, C. C. Lee, Organometallics, 3, 331 (1984).
312. D. R. Wilson, Diss. Abstr. Int. B, 45, 183 (1984).
313. A. J. Pearson, Science, 223, 895 (1984).
314. A. J. Pearson, Pure Appl. Chem., 55, 1767 (1983).
315. A. J. Pearson, I. C. Richards, D. V. Gardner, J. Org. Chem., 49, 3887 (1984).
316. L. A. Paquette, R. G. Daniels, R. Gleiter, Organometallics, 3, 560 (1984).
317. J. G. Alton, D. J. Evans, L. A. P. Kane-Maguire, G. R. Stephenson, J. Chem. Soc., Chem. Comm., 1246 (1984).
318. L. A. P. Kane-Maguire, E. D. Gonig, D. A. Sweigart, J. Chem. Soc., Chem. Comm., 345 (1984).
319. A. J. Pearson, S. L. Kole, T. Ray, J. Am. Chem. Soc., 106, 6060 (1984).
320. A. J. Pearson, P. R. Bruhin, I. C. Richards, Israel J. Chem., 24, 93 (1984).
321. J. C. Watkins, M. Rosenblum, Tetrahedron Lett., 25, 2097 (1984).
322. J. W. Herndon, Diss. Abstr. Int. B, 44, 3081 (1984).
323. M. F. Semmelhack, H. T. M. Lee, J. Am. Chem. Soc., 106, 2715 (1984).
324. A. J. Pearson, M. Nazrul, I. Khan, J. Am. Chem. Soc., 106, 1872 (1984).
325. A. J. Pearson, M. Nazrul, I. Khan, Tetrahedron Lett., 25, 3507 (1984).
326. R. Gree, M. Laabassi, P. Mosset, R. Carrie, Tetrahedron Lett., 25, 3693 (1984).
327. R. Gree, J. Kessabi, P. Mosset, J. Martelli, R. Carrie, Tetrahedron Lett., 25, 3697 (1984).
328. A. J. Birch, W. D. Raverty, G. R. Stephenson, Organometallics, 3, 1075 (1984).
329. L. M. Zubritskii, N. D. Romashchenkova, A. A. Petrov, Zh. Org. Khim., 19, 2465 (1983).
330. H. Fischer, Transition Met. Carbene Complexes, 1 (1983).
331. K. H. Dotz, Angew. Chem. Int. Ed., 23, 587 (1984).
332. M. Guo, M. Bai, Huaxue Shiji, 6, 93 (1984).
333. K. H. Doetz, Pure Appl. Chem., 55, 1689 (1983).
334. M. I. Bruce, A. G. Swincer, Adv. Organomet. Chem., 22, 59 (1983).
335. J. C. Hayes, Diss. Abstr. Int. B, 44, 3773 (1984).

336. J. Ushio, H. Nakatsuji, T. Yonezawa, J. Am. Chem. Soc., 106, 5892 (1984).
337. E. O. Fischer, R. Reitmeier, K. Ackermann, Z. Naturforsch., B: Anorg. Chem., Org. Chem., 39B, 668 (1984).
338. W. D. Wulff, K. S. Chan, P. C. Tang, J. Org. Chem., 49, 2293 (1984).
339. W. D. Wulff, P. C. Tang, J. Am. Chem. Soc., 106, 435 (1984).
340. P. C. Tang, W. D. Wulff, J. Am. Chem. Soc., 106, 1132 (1984).
341. K. H. Doetz, W. Kuhn, K. Ackermann, Z. Naturforsch., B: Anorg. Chem., Org. Chem., 38B, 1351 (1983).
342. M. A. McGuire, Diss. Abstr. Int. B, 44, 2431 (1984).
343. L. S. Hegedus, M. A. McGuire, L. M. Schultze, Y. Chen, O. P. Anderson, J. Am. Chem. Soc., 106, 2680 (1984).
344. L. S. Hegedus, A. Kramer, Organometallics, 3, 1263 (1984).
345. C. P. Casey, N. W. Vollendorf, K. J. Haller, J. Am. Chem. Soc., 106, 3754 (1984).
346. D. W. Macomber, Organometallics, 3, 1589 (1984).
347. P. Jernakoff, N. J. Cooper, J. Am. Chem. Soc., 106, 3026 (1984).
348. R. Ammarhn, H. Heiner, C. Kruger, Angew. Chem. Int. Ed., 23, 223 (1984).
349. G. J. Baird, S. G. Davies, T. R. Makerly, Organometallics, 3, 1764 (1984).
350. P. J. Curtis, S. G. Davies, J. Chem. Soc., Chem. Comm., 747 (1984).
351. G. J. Baird, S. G. Davies, R. H. Jones, P. Warner, J. Chem. Soc., Chem. Comm., 745 (1984).
352. B. H. Lipshutz, R. S. Wilhelm, J. A. Kozlowski, J. Org. Chem., 49, 3938 (1984).
353. B. H. Lipschutz, D. A. Parker, J. A. Kozlowski, S. L. Nguyen, Tetrahedron Lett., 25, 5959 (1984).
354. S. H. Bertz, G. Dabbagh, J. Org. Chem., 49, 1119 (1984).
355. T. W. Wallace, Tetrahedron Lett., 25, 4299 (1984).
356. G. Hallnemo, T. Glsson, C. Ullenius, J. Organomet. Chem., 265, C22 (1984).
357. G. Teutsch, G. Costerousse, J. Chem. Res., Synop., 294 (1983).
358. R. Noyori, M. Suzuki, Angew. Chem. Int. Ed. Engl., 23, 847 (1984).
359. E. Nakamura, I. Kuroajima, J. Am. Chem. Soc., 106, 3368 (1984).
360. Y. Ito, H. Imai, T. Matsuura, T. Saegusa, Tetrahedron Lett., 25, 3091 (1984).
361. I. Fleming, T. W. Newton, J. Chem. Soc., Perkin I, 1805 (1984).
362. J. Berlan, Y. Besace, D. Prat, G. Pourcelot, J. Organomet. Chem., 264, 399 (1984).
363. T. Takahashi, H. Okumoto, J. Tsuji, Tetrahedron Lett., 25, 1925 (1984).
364. D. Cabaret, N. Margrot, Z. Welvant, K. N. V. Duong, A. Gaudemer J. Am. Chem. Soc., 106, 2870 (1984).
365. G. H. Posner, T. P. Kogan, M. Hulce, Tetrahedron Lett., 25, 383 (1984).
366. T. R. Hoye, A. S. Magee, R. E. Rosen, J. Org. Chem., 49, 3224 (1984).
367. K. Yamamoto, M. Iijima, Y. Ogimura, J. Tsuji, Tetrahedron Lett., 25, 2813 (1984).

368. H. Brunner, B. Hammer, Angew. Chem. Int. Ed., 23, 312 (1984).
369. T. G. Back, S. Collins, K. W. Law, Tetrahedron Lett., 25, 1689 (1984).
370. M. Alderdice, C. Spino, L. Weiler, Tetrahedron Lett., 25, 1643 (1984).
371. F. Nicotra, L. Panza, G. Russo, J. Chem. Soc., Chem. Comm., 5 (1984).
372. S. H. Bertz, G. Dabbagh, J. M. Cook, V. Honkan, J. Org. Chem., 49, 1739 (1984).
373. V. M. Potapov, E. G. Solozhenko, G. V. Panova, Zh. Obshch. Khim., 54, 662 (1984).
374. D. L. Comins, R. K. Smith, E. D. Stroud, Heterocycles, 22, 339 (1984).
375. D. El-Abed, A. Jellal, M. Santelli, Tetrahedron Lett., 25, 1463 (1984).
376. D. Roulet, J. Caperos, A. Jacot-Guillarmod, Helv. Chim. Acta., 67, 1475 (1984).
377. T. Kauffmann, M. Bisling, Tetrahedron Lett., 25, 293 (1984).
378. F. Ungvary, J. Chem. Soc., Chem. Comm., 824 (1984).
379. J. F. Helling, U. S. Gill, J. Organomet. Chem., 264, 353 (1984).
380. E. Farnetti, F. Vinzi, G. Mestroni, J. Mol. Catal., 24, 147 (1984).
381. M. A. Aramendia, V. Borau, M. C. Gomez, C. Jimenez, J. M. Marinas, Appl. Catal., 8, 177 (1984).
382. L. Marko, J. Organomet. Chem., 261 485 (1984).
383. A. Kasahara, T. Izumi, H. Yanai, Chem. Ind. (London), 898 (1983).
384. M. I. Terekhova, A. D. Karpyuk, N. D. Kolosova, E. S. Petrov, I. P. Beletskaya, Izv. Akad. Nauk SSSR, Ser. Khim., 2413 (1983).
385. T. Hayashi, M. Tanaka, I. Ogata, J. Mol. Catal., 26, 17 (1984).
386. S. B. Fergusson, H. Alper, J. Chem. Soc., Chem. Comm., 1349 (1984).
387. M. T. Crimmus, S. W. Masaearella, J. A. DeLoach, J. Org. Chem., 49, 3033 (1984).
388. R. C. Larock, L. W. Harrison, J. Am. Chem. Soc., 106, 4218 (1984).
389. R. C. Larock, D. R. Leach, J. Org. Chem., 49, 2144 (1984).
390. M. F. Semmelhack, C. Bodurow, M. Baum, Tetrahedron Lett., 25, 3171 (1984).
391. M. F. Semmelhack, C. Bodurow, J. Am. Chem. Soc., 106, 1496 (1984).
392. L. S. Hegedus, R. J. Perry, J. Org. Chem., 49, 2570 (1984).
393. F. J. Fananas, H. Hoberg, J. Organomet. Chem., 275, 249 (1984).
394. H. Alper, F. W. Hartstock, B. Despeyroux, J. Chem. Soc., Chem. Comm., 905 (1984).
395. P. S. Pregosin, R. Ruedi, J. Organomet. Chem., 273, 401 (1984).
396. R. D. O'Sullivan, A. W. Parkins, J. Chem. Soc., Chem. Comm., 1165 (1984).
397. G. Delogu, G. Fredda, S. Gladialli, J. Organomet. Chem., 268, 167 (1984).
398. J. Grobe, H. Zimmermann, Z. Naturforsch., 39B, 962 (1984).
399. H. Yamazaki, P. Hong, J. Mol. Catal., 21, 133 (1983).
400. V. N. Zudin, G. N. Ilinick, V. A. Likholobov, Y. I. Yermakov, J. Chem. Soc., Chem. Comm., 545 (1984).

401. L. Y. Startseva, V. A. Semikolenov, A. S. Lisitsyn, V. A. Likholobov, Y. I. Ermakov, Kinet. Katal., **25**, 506 (1984).
402. K. Murata, A. Matsuda, Kagaku Gijutsu Kenkyusho Hokoku, **79**, 165 (1984).
403. C. U. Pittman, L. I. Flowers, Q. Ng, Prepr. Am. Chem. Soc., Div. Pet. Chem., **27**, 614 (1982).
404. W. A. Smit, A. A. Schegolev, A. S. Gybin, G. S. Mikaelian, Synthesis, 887 (1984).
405. D. C. Billington, D. Willison, Tetrahedron Lett., **25**, 4044 (1984).
406. N. E. Schore, B. E. LaBelle, M. J. Knudsen, H. Hope, X-T. Xu, J. Organomet. Chem., **272**, 435 (1984).
407. L. Daalman, R. F. Newton, P. L. Pauson, R. G. Taylor, A. Wadsworth, J. Chem. Res. (S), 344 (1984).
408. L. Daalman, R. F. Newton, P. L. Pauson, A. Wadsworth, J. Chem. Res. (S), 346 (1984).
409. A. J. Birch, W. D. Raverty, S-Y. Hsu, A. J. Pearson, J. Organomet. Chem., **260**, C59 (1984).
410. D. L. Reger, E. Mintz, Organometallics, **3**, 1759 (1984).
411. M. F. Semmelhack, J. W. Herndon, J. Organomet. Chem., **265**, C15 (1984).
412. A. P. Marchand, D. B. Goodin, M. B. Hossain, D. vander Helm, J. Org. Chem., **49**, 2897 (1984).
413. H. Flechner, F-W. Grevels, D. Hess, J. Am. Chem. Soc., **106**, 2027 (1984).
414. F. J. Fananas, H. Hoberg, J. Organomet. Chem., **277**, 135 (1984).
415. H. Hoberg, B. Apotecher, J. Organomet. Chem., **270**, C15 (1984).
416. H. Hoberg, D. Schaefer, G. Burkhart, C. Kruger, M. J. Ramao, J. Organomet. Chem., **266**, 203 (1984).
417. K. Sakai, Y. Ishiguro, K. Funakoshi, K. Ueno, H. Suemune, Tetrahedron Lett., **25**, 961 (1984).
418. K. Ueno, H. Suemune, K. Sakai, Chem. Pharm. Bull., **32**, 3768 (1984).
419. P. Eilbracht, E. Balb, M. Acker, Tetrahedron Lett., **25**, 1131 (1984).
420. P. G. M. Wuts, M. L. Obrzut, P. A. Thompson, Tetrahedron Lett., **25**, 4051 (1984).
421. A. F. Noels, A. J. Hubert, J. Mol. Catal., **22**, 235 (1983).
422. B. Fell, H. U. Hoeg, Forschungsber. Landes Nordrhein-Westfalen, 3105 (1982).
423. K. Murata, A. Matsuda, Kagaku Gijutsu Kenkyusho Hokoku, **79**, 149 (1984).
424. P. DeShong, G. A. Slough, Organometallics, **3**, 636 (1984).
425. G. Erker, U. Dorf, R. Benn, R-D. Reinhardt, J. Am. Chem. Soc., **106**, 7649 (1984).
426. M. Mori, G. E. Purvaneckas, M. Ishikura, Y. Ban, Chem. Pharm. Bull., **32**, 3840 (1984).
427. M. Mori, M. Kimura, Y. Ban, M. Ishikura, Tennen Yuki Kagobutsu Toronkai Koen Yoshishu, 484 (1983).

428. M. Mori, M. Ishikura, T. Ikeda, Y. Ban, Heterocycles, 22, 253 (1984).
429. W. F. Goure, M. E. Wright, P. D. Davis, S. S. Labadie, J. K. Stille, J. Am. Chem. Soc., 106, 6417 (1984).
430. J. H. Merrifield, J. P. Godschalx, J. K. Stille, Organometallics, 3, 1108 (1984).
431. R. A. Head, A. Ibbatson, Tetrahedron Lett., 25, 5939 (1984).
432. K. Inamasa, K. Kudo, N. Sugita, Bull. Inst. Chem. Res., Kyoto Univ., 61, 282 (1983).
433. I. Pri-Bar, O. Buchman, J. Org. Chem., 49, 4009 (1984).
434. Y. Tamaru, H. Ochiai, Z-i. Yoshida, Tetrahedron Lett., 25, 3861 (1984).
435. H. Alper, S. Antebi, J. B. Woell, Angew. Chem. Int. Ed., 23, 732 (1984).
436. J. B. Woell, H. Alper, Tetrahedron Lett., 25, 3791 (1984).
437. T. Suzuki, T. Matsuki, K. Kudo, N. Sugita, Nippon Kagaku Kaishi, 1482 (1983).
438. G. C. Tustin, R. T. Hembre, J. Org. Chem., 49, 1761 (1984).
439. I. Ryu, M. Ryang, I. Rhee, H. Omura, S. Murai, N. Sonoda, Synth. Comm., 14, 1175 (1984).
440. G. Tanguy, B. Weinberger, H. des Abbayes, Tetrahedron Lett., 25, 5529 (1984).
441. Y. Watanabe, Y. Tsuji, R. Takeuchi, Bull. Chem. Soc. Jpn., 56, 3343 (1983).
442. Y. Watanabe, Y. Tsuji, T. Ohsumi, R. Takeguchi, Bull. Chem. Soc. Jpn., 57, 2867 (1984).
443. Y. Watanabe, Y. Tsuji, R. Takeuchi, Bull. Chem. Soc. Jpn., 57, 3011 (1984).
444. S. Cenini, M. Pizzotti, C. Crotti, F. Purta, G. La Monica, J. Chem. Soc., Chem. Comm., 1286 (1984).
445. S. P. Gupte, R. V. Chaudhari, J. Mol. Catal., 24, 197 (1984).
446. S. B. Halligudi, R. V. Chaudhari, L. K. Doraiswamy, Eng. Chem. Process Des. Dev., 23, 794 (1984).
447. H. Tietz, P. Neitzel, K. Schwetlick, R. Szargan, Z. Chem., 24, 186 (1984).
448. G. A. Abakumov, I. L. Knyazeva, N. N. Vavilina, L. V. Gorbunova, S. V. Zhivtsova, Izv. Akad. Nauk SSSR, Ser. Khim., 1352 (1984).
449. S. Fukuoka, M. Chono, M. Kohno, J. Org. Chem., 49, 1458 (1984).
450. S. Fukuoka, M. Chono, M. Kohno, J. Chem. Soc., Chem. Comm., 399 (1984).
451. F. Ozawa, T. Sugimoto, Y. Yuasa, M. Santna, T. Yamamoto, A. Yamamoto, Organometallics, 3, 683 (1984).
452. F. Ozawa, T. Sugimoto, T. Yamamoto, A. Yamamoto, Organometallics, 3, 692 (1984).
453. J.-T. Chen, A. Sen, J. Am. Chem. Soc., 106, 1506 (1984).
454. M. Nitta, T. Kobayashi, Bull. Chem. Soc. Jpn., 57, 1035 (1984).
455. W. Danzer, R. Hofer, H. Menzel, B. Olgemoller, W. Beck, Z. fur. Naturforsch. B, 39B, 167 (1984).
456. S. Matsuhira, Yuki Gosei Kagaku Kyokaiishi, 42, 115 (1984).



457. L. N. Zhir-Lebed, O. N. Temkin, Deposited Doc., SPSTL (1982).
458. J. Tsuji, K. Sato, H. Okumoto, J. Org. Chem., **49**, 1341 (1984).
459. G. T. Crisp, W. J. Scott, J. K. Stille, J. Am. Chem. Soc., **106**, 7500 (1984).
460. N. Chatani, H. Furukawa, T. Kato, S. Murai, N. Sonada, J. Am. Chem. Soc., **106**, 430 (1983).
461. K. C. Brinkman, J. A. Gladysz, Organometallics, **3**, 147 (1984).
462. M. Franck-Neumann, Pure Appl. Chem., **55**, 1715 (1983).
463. G. Erker, Acc. Chem. Res., **17**, 103 (1984).
464. M. Uchiyama, T. Suzuki, Nippon Kagaku Kaishi, 585 (1984).
465. K. Kikukawa, T. Totaki, F. Wada, T. Matsuda, J. Organomet. Chem., **270**, 283 (1984).
466. C. Zlotogorski, J. Blum, E. Osawa, H. Schwarz, G. Hohne, J. Org. Chem., **49**, 971 (1984).
467. J. W. Suggs, C-H. Jun, J. Am. Chem. Soc., **106**, 3055 (1984).
468. D. H. Doughty, L. H. Pignolet, Homogeneous Catal. Met. Phosphine Complexes, 343 (1983).
469. J. D. Atwood, T. S. Janik, M. F. Pyszczek, P. S. Sullivan, Ann. N. Y. Acad. Sci., **415**, 259 (1983).
470. F. Delgado, A. Cabrera, J. Gomez-Lara, J. Mol. Catal., **22**, 83 (1983).
471. J. Tsuji, M. Nisar, I. Shimizu, I. Minami, Synthesis, 1009 (1984).
472. D. J. Darensbourg, R. A. Kudaroski, Adv. Organomet. Chem., **22**, 129 (1983).
473. H. Sugimoto, I. Kawata, H. Taniguchi, Y. Fujiwara, J. Organomet. Chem., **266**, C44 (1984).
474. J. F. Fanvarque, C. Chevrot, A. Jutand, M. Francois, J. Organomet. Chem., **264**, 273 (1981).
475. A. Behr, U. Kanne, G. Thelen, J. Organomet. Chem., **269**, C1 (1984).
476. E. Dinjus, D. Walther, H. Schuetz, W. Schade, Z. Chem., **23**, 303 (1983).
477. H. Hoberg, D. Schaeffer, B. W. Oster, J. Organomet. Chem., **266**, 313 (1984).
478. P. Binger, H. J. Weintz, Chem. Ber., **117**, 654 (1984).
479. Y. Hayashi, S. Komija, T. Yamamoto, A. Yamamoto, Chem. Lett., 977 (1984).
480. O. Toussaint, P. Capderrelle, M. Maung, Tetrahedron, **40**, 3229 (1984).
481. L. Bonneviot, D. Olivier, M. Che, J. Mol. Catal., **21**, 415 (1983).
482. L. I. Zaks, Deposited Doc., VINITI 6343-82 (1982).
483. S. S. Zhukovskii, B. M. Fedorov, A. M. Taber, I. V. Kalechits, V. E. Vasserberg, Kinet. Katal., **25**, 62 (1984).
484. P. Binger, J. McMeeking, H. Schafer, Chem. Ber., **117**, 1551 (1984).
485. M. Peuckert, W. Keim, J. Mol. Catal., **22**, 289 (1984).
486. G. M. Shakhnazaryan, L. A. Saakyan, R. S. Avoyan, Sh. L. Shakhbatyan, Arm. Khim. Zh., **36**, 504 (1983).
487. P. Grenouillet, D. Neibecker, I. Tkatchenko, Organometallics, **3**, 1130 (1984).

488. G. Oehme, J. F. Prakt. Chem., **326**, 779 (1984).
489. P. O. Nubel, T. L. Brown, J. Am. Chem. Soc., **106**, 3474 (1984).
490. A. G. Azizov, D. B. Akhmedov, S. M. Aliev, Neftekhimiya, **24**, 353 (1984).
491. F. A. Selimov, O. G. Rutman, U. M. Dzhemilev, Zh. Org. Khim., **19**, 1853 (1983).
492. T. Matsuda, T. Higashimura, Acc. Chem. Res., **17**, 51 (1984).
493. A. Furlani, M. V. Russo, P. Carusi, S. Licoccia, E. Leoni, G. Valenti, Gazz. Chim. Ital., **113**, 671 (1983).
494. H. Fuellbier, W. Gaube, Wiss. Z. Ernst-Moritz-Arndt-Univ. Greifsw., Math.-Naturwiss. Reihe, **31**, 35 (1982).
495. P. Denis, A. Mortreux, F. Petit, G. Buono, G. Peiffa, J. Org. Chem., **49**, 5276 (1984).
496. D. Neibecker, M. Touma, I. Tkatchenko, Synthesis, 1023 (1984).
497. H. T. Dieck, J. Dietrich, Chem. Ber., **117**, 694 (1984).
498. P. Vioget, M. Bonivento, R. Roulet, P. Vogel, Helv. Chim. Acta, **67**, 1638 (1984).
499. H. J. T. Bos, V. H. M. Elferink, D. vander Ploeg, Rec. Trav. Chim., **103**, 301 (1984).
500. A. Behr, G. von Ilseman, J. Organomet. Chem., **276**, C77 (1984).
501. Y. Inoue, Y. Ohtsuka, H. Hashimoto, Bull. Chem. Soc., Jpn., **57**, 3345 (1984).
502. M. Bochmann, M. Thomas, J. Mol. Catal., **26**, 79 (1984).
503. A. B. Amerik, Deposited Doc., VINITI 6343-82 (1982).
504. L. I. Zakharkin, E. A. Petrushkina, Zh. Org. Khim., **20**, 490 (1984).
505. M. Bochmann, M. Thomas, J. Mol. Catal., **22**, 363 (1984).
506. T. Bartik, P. Heimbach, T. Himmler, J. Organomet. Chem., **276**, 399 (1984).
507. N. G. Marina, Yu. B. Monakov, S. R. Rafikov, V. I. Ponomarenko, Russ. Chem. Rev., **52**, 413 (1983).
508. B. A. Dolgoplosk, E. I. Tinzakova, Russ. Chem. Rev., **53**, 22 (1984).
509. B. A. Dolgoplosk, Yu. V. Korshak, Russ. Chem. Rev., **53**, 36 (1984).
510. V. F. Tsvetkov, V. M. Kazantseva, V. S. Pisareva, N. V. Korzhova, S. P. Korshunov, L. I., Azerb. Khim. Zh., **13** (1983).
511. T. Kauffmann, J. Ennen, K. Berghus, Tetrahedron Lett., **25**, 1971 (1984).
512. R. Tauke, U. Schmidt, J-P. Gehrke, U. Anacker, J. fur Prakt. Chem., **326**, 1 (1984).
513. N. T. Byrom, R. Grigg, B. Kongkathip, G. Reimer, A. R. Wade, J. Chem. Soc., Perkin I, 1643 (1984).
514. A. Behr, R. He, J. Organomet. Chem., **276**, C69 (1984).
515. W. Gaube, H. Stegemann, J. Prakt. Chem., **326**, 729 (1984).
516. R. M. Safuanova, R. N. Fakhretdinov, U. M. Dzhemilev, Izv. Akad. Nauk SSSR, Ser. Khim., 703 (1984).

517. R. Bortolin, A. Musco, J. Mol. Catal., 22, 319 (1984).
518. A. Citterio, E. Comunale, A. Musco, J. Chem. Res., Synop., 77 (1984).
519. R. N. Fakhretdinov, R. N. Khusnitdinov, I. B. Abdrakhmanov, U. M. Dzhemilev, Zh. Org. Khim., 20, 1101 (1984).
520. M. A. Moskalenko, A. B. Terent'ev, Izv. Akad. Nauk SSSR, Ser. Khim., 2322 (1983).
521. T-W. Lai, A. Sen, Organometallics, 3, 866 (1984).
522. C. Y. Hoang, A. U. Krylova, A. L. Lapidus, Izv. Akad. Nauk SSSR, Ser. Khim., 1702 (1984).
523. N. DeKimpe, B. DeCorte, R. Verhe, L. DeBuyck, N. Schamp, Tetrahedron Lett., 25, 1095 (1984).
524. K. P. C. Vollhardt, Angew. Chem. Int. Ed., 23, 539 (1984).
525. K. P. C. Vollhardt, Strategies Tactics Org. Synth., 299 (1984).
526. B. C. Berris, Diss. Abstr. Int. B, 45, 872 (1984).
527. E. D. Sternberg, K. P. C. Vollhardt, J. Org. Chem., 49, 1564 (1984).
528. E. D. Sternberg, K. P. C. Vollhardt, J. Org. Chem., 49, 1574 (1984).
529. H. Sakurai, Y. Nakadaira, A. Hosomi, Y. Eriyama, K. Hirama, C. Kabuto, J. Am. Chem. Soc., 106, 8315 (1984).
530. M. E. E. Meijer-Veldman, H. J. Liefdemeijer, J. Organomet. Chem., 260, 199 (1984).
531. A. Mantovani, A. Marcomini, L. Calligaro, U. Belluco, Congr. Naz. Chim. Inorg., 206 (1983).
532. J. Grobe, B. H. Schmeider, H. Zimmerman, Z. Naturforsch. 39b, 957 (1984).
533. R. Diercks, L. Stamp, J. Kopf, H. Iom Dieck, Angew. Chem. Int. Ed., 23, 892 (1984).
534. R. Diercks, H. t. Dieck, Z. fur Naturforsch., 39b, 180 (1984).
535. R. Diercks, L. Stamp, H. t. Dieck, Chem. Ber., 117, 1913 (1984).
536. H. Bonnemann, W. Brijoux, R. Brinkmann, W. Meurers, Helv. Chim. Acta, 67, 1616 (1984).
537. G. P. Chiusoli, L. Pallini, G. Terenghi, Transition Met. Chem., 9, 360 (1984).
538. R. E. Geiger, M. Lalonde, H. Stoller, K. Schleich, Helv. Chim. Acta, 67, 1274 (1984).
539. E. R. F. Gesing, U. Groth, K. P. C. Vollhardt, Synthesis, 351 (1984).
540. E. Martelli, C. Pelizzi, G. Predieri, J. Mol. Catal., 22, 89 (1983).
541. K. J. Ivin, "Olefin Metathesis", Academic Press, London, UK (1983) p. 399.
542. H. Balcar, Chem. Listy, 78, 35 (1984).
543. T. Kawai, Y. Yamazaki, A. Tokumura, Sekiyu Gakkaishi, 26, 332 (1983).
544. C. Boelhouwer, J. C. Mol., JAOCs, J. Am. Oil Chem. Soc., 61, 425 (1984).
545. R. H. A. Bosma, G. C. N. Van den Aardweg, J. C. Mol., J. Organomet. Chem., 255, 159 (1983).

546. H. Balcar, A. Dosedlova, V. Hanus, L. Petrusova, B. Matyska, Collect. Czech. Chem. Commun., **49**, 1736 (1984).
547. J. Levisalles, H. Rudler, D. Cuzin, T. Rull, J. Mol. Catal., **26**, 231 (1984).
548. E. F. G. Woerlee, R. H. A. Bosma, J. M. M. Van Eijl, J. C. Mol., Appl. Catal., **10**, 219 (1984).
549. T. Kawai, Y. Yamazaki, M. Nishikawa, Sekiyu Gakkaishi, **27**, 378 (1984).
550. B. Marciniac, J. Gulinski, J. Organomet. Chem., **266** C19 (1984).
551. K. Weiss, P. Kindl, Angew. Chem. Int. Ed., **23**, 629 (1984).
552. K. Weiss, Stud. Surf. Sci. Catal., **19**, 397 (1984).
553. L. K. Fong, N. J. Cooper, J. Am. Chem. Soc., **106**, 2595 (1984).
554. J. G. Hamilton, K. J. Ivin, G. M. McCann, J. J. Rooney, J. Chem. Soc., Chem. Comm., 1379 (1984).
555. L. Bencze, A. Karut-Vass, J. Organomet. Chem., **270**, 211 (1984).
556. C. Larroche, J. P. Laval, A. Lattes, J. M. Bassett, J. Org. Chem., **49**, 1886 (1984).
557. T. J. Katz, T. H. Ho, N-Y. Shih, Y-C. Ying, V. I. W. Stuart, J. Am. Chem. Soc., **106**, 2659 (1984).
558. M. R. Churchill, J. W. Ziller, J. H. Freudenberger, R. R. Schrock, Organometallics, **3**, 1554, 1563 (1984).
559. D. K. Benev, K. Yu. Adzhamov, T. G. Alkhozov, Geterog. Katal., 485 (1983).
560. A. L. Sen, Ta Wang, Inorg. Chem., **23**, 3257 (1984).
561. K. Mach, H. Antropiusova, V. Hanus, F. Turecek, P. Sedmera, J. Organomet. Chem., **269**, 39 (1984).
562. Y. L. Chow, G. E. Buono-Core, Y. Shen, Organometallics, **3**, 702 (1984).
563. Y. Tamaru, Y. Yamada, H. Ochiai, E. Nakajo, Z. Yoshida, Tetrahedron, **40**, 1791 (1984).
564. A. C. Ochlschlager, P. Mishra, S. Dhami, Can. J. Chem., **62**, 791 (1984).
565. Y. Yamada, G. Suzukamo, H. Yoshioka, Tetrahedron Lett., **25**, 3599 (1984).
566. X. Lu, Y. Huang, Huaxue Xuebao, **42**, 835 (1984).
567. J. Tsuji, I. Minami, I. Shimizu, Tetrahedron Lett., **25**, 2791 (1984).
568. J. Tsuji, I. Minami, I. Shimazu, H. Kaloaka, Chem. Lett., 1133 (1984).
569. J. Tsuji, I. Minami, I. Shimizu, Chem. Lett., 1721 (1984).
570. C. Georgoulis, J. M. Valery, G. Ville, Synth. Comm., **14**, 1043 (1984).
571. A. V. Mushegyan, V. Kh. Ksiperidis, A. O. Gukasyan, O. A. Kamalyan, G. G. Grigoryan, Kinet. Katal., **25**, 81 (1984).
572. S. Achab, J-P. Cosson, B. C. Das, J. Chem. Soc., Chem. Comm., 1040 (1984).
573. R. Grigg, P. J. Stevenson, Synthesis, 1009 (1983).
574. A. B. Holms, K. Russell, E. S. Stern, M. E. Stubbs, N. K. Wellard, Tetrahedron Lett., **25**, 4163 (1984).
575. S. Otsuka, Fundam. Homogeneous Catal., **4**, 145 (1984).

576. K. Tani, T. Yamagata, S. Akutagawa, H. Kumobayashi, T. Takotomi, H. Takaya, A. Miyashita, R. Noyori, S. Otsuka, J. Am. Chem. Soc., 106, 5208 (1984).
577. R. J. P. Corriu, V. Huynh, J. I. Qubal, J. J. E. Moreau, J. Organomet. Chem., 276, C61 (1984).
578. N. Capps, G. M. Davies, D. W. Young, Tetrahedron Lett., 25, 4157 (1984).
579. S. Yano, S. Yoshikawa, Kagaku (Kyoto), 38, 890 (1983).
580. O. V. Bragin, S. A. Krasavin, Russ. Chem. Rec., 52, 625 (1983).
581. O. E. Finlayson, J. K. A. Clarke, J. J. Rooney, J. Chem. Soc., Faraday Trans. 1, 80, 191 (1984).
582. N. Borsub, C. Katal, J. Am. Chem. Soc., 106, 4826 (1984).
583. T. B. Patrick, D. S. Bechtold, J. Org. Chem., 49, 1935 (1984).
584. K. Yokoyama, Y. Saegusa, T. Miyashi, C. Kabuto, T. Mukai, Chem. Lett., 89 (1984).
585. L. E. Overman, Angew. Chem. Int. Ed., 23, 579 (1984).
586. E. J. Jacobsen, Diss. Abstr. Int. B., 45, 190 (1984).
587. Y. Morizawa, K. Oshima, H. Nozaki, Israel J. Chem., 24, 149 (1984).
588. K. S. Kyler, A. Bashir-Hashemi, D. S. Watt, J. Org. Chem., 49, 1084 (1984).
589. A. B. Goel, Inorg. Chim. Acta, 86, L77 (1984).
590. J. Muzart, J. P. Pete, Bull. Soc. Chim. Fr., 56 (1984).
591. S. Uemura, M. Okano, Bull. Inst. Chem. Res., Kyoto Univ., 61, 363 (1983).
592. C. J. Elsevier, H. J. T. Bos, P. Vermeer, J. Org. Chem., 49, 379 (1984).
593. C. A. Horiuchi, J. Y. Satoh, Chem. Lett., 1509 (1984).
594. C. J. Elsevier, P. Vermeer, J. Org. Chem., 49, 1649 (1984).
595. K. Carr, J. K. Sutherland, J. Chem. Soc., Chem. Comm., 1227 (1984).
596. F. Chauvet, A. Heumann, B. Waegell, Tetrahedron Lett., 25, 4393 (1984).
597. H. Arzoumanian, R. Lai, J. Metzger, J-F. Petrignani, J. Organomet. Chem., 267, 207 (1984).
598. K. D. Donnelly, W. E. Fristad, B. J. Gellerman, J. R. Peterson, B. J. Selle, Tetrahedron Lett., 25, 607 (1984).
599. R. D. Dave, T. F. Molinski, J. V. Turner, Tetrahedron Lett., 25, 2061 (1984).
600. Y. Ito, H. Imai, K. Segoe, T. Saegusa, Chem. Lett., 937 (1984).
601. H. M. R. Hoffmann, L. Iranshahi, J. Org. Chem., 49, 1174 (1984).
602. W. R. Jackson, C. G. Lovel, Aust. J. Chem., 36, 1975 (1983).
603. J. E. Backvall, O. V. Andell, J. Chem. Soc., Chem. Comm., 260 (1984).
604. C. A. Tolman, W. C. Seidel, J. P. Druliner, P. J. Domaille, Organometallics, 3, 33 (1984).
605. Y. Inoue, M. Takeguchi, M. Toyofuku, H. Hashimoto, Bull. Chem. Soc., Japan, 57, 3021 (1984).
606. R. Perrone, F. Berardi, V. Tortoreka, Gazz. Chim. Ital., 113, 221 (1983).
607. B. M. R. Bandara, A. J. Birch, L. F. Kelly, J. Org. Chem., 49, 2496 (1984).

608. T. Beisswenger, F. Effenberger, Chem. Ber., 117, 1513 (1984).
609. L. S. Hegedus, B. Akermark, K. Zetterberg, J. Am. Chem. Soc., 106, 7122 (1984).
610. B. Akermark, K. Zetterberg, J. Am. Chem. Soc., 106, 5560 (1984).
611. I. Shimizu, J. Tsuji, Chem. Lett., 233 (1984).
612. J. Ipaktschi, Chem. Ber., 117, 856 (1984).
613. M. J. K. Geno, J. H. Dawson, Inorg. Chem., 23, 509 (1984).
614. R. M. Laine, B. R. Cho, R. B. Wilson, Jr., C1 Mol. Chem., 1, 1 (1984).
615. R. Imwinkelried, D. Seebach, Helv. Chim. Acta, 67, 1496 (1984).
616. Y. Li, Y. Jiang, Gaofenzi Tongxun, 53 (1984).
617. A. Ono, M. Hiroi, K. Shimazaki, Chem. Ind. (London), 75 (1984).
618. S. Bhattacharya, P. K. Santra, C. R. Saha, Indian J. Chem., Sect. A, 23A, 724 (1984).
619. S. Ram, R. E. Ehrenkauffer, Tetrahedron Lett., 25, 3415 (1984).
620. Q. F. Seaton, C. W. Lawley, H. A. Akers, Anal. Biochem., 138, 238 (1984).
621. G. Lunn, E. B. Sansone, L. K. Keefer, J. Org. Chem., 49, 3470 (1984).
622. E. Alessio, F. Vinzi, G. Mestroni, J. Mol. Catal., 22, 327 (1984).
623. Y. Watanabe, Y. Tsuji, H. Ige, Y. Ohsugi, T. Ohta, J. Org. Chem., 49, 3359 (1984).
624. Y. Tsuji, J. Shida, R. Takeguchi, Y. Watanabe, Chem. Lett., 889 (1984).
625. H. Hoberg, K. Summermann, Z. Naturforsch. B., 39b, 1032 (1984).
626. R. Carlson, A. Nilsson, Acta Chem. Scan. B., 38, 49 (1984).
627. Z. Zhou, S. Wu, Y. Zhou, Lanzhou Daxue Xuebao Ziran Kexueban, 19, 171 (1983).
628. C. Qian, D. Deng, H. Zhou, L. Shi, Huaxue Xuebao, 42, 80 (1984).
629. H. S. Lee, K. Isagawa, F. Toyoda, Y. Otsuji, Chem. Lett., 673 (1984).
630. G. Read, J. Shaw, J. Chem. Soc., Chem. Comm., 1313 (1984).
631. N. Rosas, G. Sotelo, A. Cabrera, Bol. Soc. Chil. Quim., 28, 29 (1983).
632. T. Okamoto, S. Oka, J. Org. Chem., 49, 1589 (1984).
633. A. B. Solov'eva, V. I. Mel'nikova, K. K. Pivnitskii, E. I. Karakozova, K. A. Bogdanova, L. V. Karmilova, G. A. Nikiforov, N. S. Enikolopov, Izv. Akad. Nauk SSSR, Ser. Khim., 2327 (1983).
634. K. Tamao, I. Iwahara, R. Kanatari, M. Kumada, Tetrahedron Lett., 25, 1909 (1984).
635. A. K. Mahapatra, D. Bandyopadhyay, P. Bandyopadhyay, A. Chakravorty, J. Chem. Soc., Chem. Comm., 999 (1984).
636. M. Onishi, M. Matsuda, K. Hiraki, Chem. Lett., 1157 (1984).
637. T. A. Smith, P. M. Maitlis, J. Organomet. Chem., 269, C7 (1984).
638. R. Spogliarich, G. Mestroni, M. Graziani, J. Mol. Catal., 22, 309 (1984).
639. T. Okamoto, S. Oka, J. Mol. Catal., 23, 107 (1984).
640. H. Brunner, K. Becker, G. Riepl, Organometallics, 3, 1354 (1984).
641. C. R. Johnson, M. R. Barbachyn, J. Am. Chem. Soc., 106, 2459 (1984).
642. C-S. Chien, T. Suzuki, T. Kawasaki, M. Sakamoto, Chem. Pharm. Bull., 32, 3945 (1984).

643. F. Fournier, J. Berthdot, Y. L. Pascal, Tetrahedron, **40**, 339 (1984).
644. M. Takahashi, H. Urata, H. Suzuki, Y. Moro-oka, T. Ikawa, J. Organomet. Chem., **266**, 327 (1984).
645. S. S. Hall, B. Akermark, Organometallics, **3**, 1745 (1984).
646. J. E. Backvall, Pure Appl. Chem., **55**, 1669 (1983).
647. J. E. Backvall, S. E. Bystrom, R. E. Nordberg, J. Org. Chem., **49**, 4619 (1984).
648. M. Nikaido, R. Aslanian, F. Scavo, P. Helquist, B. Akermark, J. E. Backvall, J. Org. Chem., **49**, 4738 (1984).
649. J. E. Backvall, J. Vagberg, R. E. Nordberg, Tetrahedron Lett., **25**, 2717 (1984).
650. B. Akermark, J. E. Nystrom, T. Rein, J. E. Backvall, Tetrahedron Lett., **25**, 5719 (1984).
651. A. Heumann, B. Akermark, Angew. Chem. Int. Ed., **23**, 453 (1984).
652. J. E. McMurray, P. Kocovsky, Tetrahedron Lett., **25**, 4187 (1984).
653. N. K. Dunlap, M. R. Sabol, D. S. Watt, Tetrahedron Lett., **25**, 5839 (1984).
654. K. Ogura, N. Shibuy, K. Takahashi, H. Iida, Bull. Chem. Soc. Jpn., **57**, 1092 (1984).
655. S. Kim, J. I. Lee, J. Org. Chem., **49**, 1712 (1984).
656. D. Ugeren, Tetrahedron Lett., **25**, 541 (1984).
657. Y. Blum, Y. Shuo, J. Organomet. Chem., **263**, 93 (1984).
658. Y. Masuyama, M. Takahashi, Y. Kurusu, Tetrahedron Lett., **25**, 4417 (1984).
659. N. N. Tsekhina, B. G. Freidin, I. G. Uryukina, Neftkhimiya, **24**, 63 (1984).
660. S. Ito, K. Ashara, M. Matsumoto, Tetrahedron Lett., **25**, 3891 (1984).
661. M. Hirano, T. Morimoto, J. Chem. Soc., Perkin Trans II, 1033 (1984).
662. A. K. Chakraborti, B. K. Banik, U. R. Ghatak, Indian J. Chem. Sect. B, **23B**, 291 (1984).
663. M. Utaka, M. Hojo, Y. Fujii, A. Takeda, Chem. Lett., 635 (1984).
664. G. Green, W. P. Griffith, D. M. Hollinshead, S. V. Ley, M. Schroder, J. Chem. Soc., Perkin Trans. I, 681 (1984).
665. H. Kunz, H. Waldmann, Angew. Chem. Int. Ed., **23**, 71 (1984).
666. K. Jitsukawa, K. Kaneda, S. Teranishi, J. Org. Chem., **49**, 199 (1984).
667. M. V. Shimanskaya, J. Osis, A. A. Anderson, Khim. Geterotsikl. Soedin., 1587 (1983).
668. C. L. Liu, Diss. Abstr. Int. B, **44**, 3 (1984).
669. Y. Ohshiro, T. Hirao, Heterocycles, **22**, 859 (1984).
670. C. A. Parnell, Diss. Abstr. Int. B, **45**, 877 (1984).
671. A. Nose, T. Kudo, Chem. Pharm. Bull., **32**, 2421 (1984).
672. B. V. Polyakov, V. P. Tverdokhlebov, I. V. Tselinskii, N. M. Bakstova, G. M. Frolova, Zh. Obshch. Khim., **53**, 2046 (1983).
673. A. Y. Yuffa, A. A. Slinkin, V. V. Berentsveig, A. V. Kucherov, B. B. Ryabova, A. Y. Stakheev, Izv. Akad. Nauk SSSR, Ser. Khim., 1698 (1984).
674. D. Schnurpfeil, J. Prakt. Chem., **325**, 842 (1983).

675. R. Nagata, T. Matsuura, I. Saito, Tetrahedron Lett., 25, 2691 (1984).
676. M. A. Andrews, T. C. T. Chang, C-W. F. Cheng, K. P. Kelly, Organometallics, 3, 1777 (1984).
677. G. Balavoine, C. Eskenazi, F. Meunier, H. Riviero, Tetrahedron Lett., 25, 3187 (1984).
678. K. C. Nicolaou, M. E. Duggan, T. Ladduwahetty, Tetrahedron Lett., 25, 2069 (1984).
679. B. De Porter, B. Meunier, Tetrahedron Lett., 25, 1895 (1984).
680. D. Mansuy, P. Battioni, J-P. Renaud, J. Chem. Soc., Chem. Comm., 1255 (1984).
681. B. Meunier, E. Guilmet, M-E. De carbalho, R. Poilbanc, J. Am. Chem. Soc., 106, 6668 (1984).
682. E. Guilmet, B. Meunier, J. Mol. Catal., 23, 115 (1984).
683. H. J. Ledon, F. Varescon, Chem. Uses Molybdenum Proc. Int. Conf., 4th, 319 (1982).
684. M. Yamazaki, H. Endo, M. Tomoyama, Y. Kurusu, Bull. Chem. Soc. Jpn., 56, 3523 (1983).
685. V. P. Rajan, S. N. Bannore, H. N. Subbarao, S. Dev, Tetrahedron, 40, 983 (1984).
686. Y. Matoba, H. Inoue, J-i. Akagi, T. Okabayashi, Y. Ishii, M. Ogawa, Synth. Comm., 14, 865 (1984).
687. P. S. Traylor, D. Dolphin, T. G. Traylor, J. Chem. Soc., Chem. Comm., 279 (1984).
688. C. C. Franklin, R. B. Van Atta, A. Fantai, J. S. Valentine, J. Am. Chem. Soc., 106, 814 (1984).
689. K. B. Sharpless, S. S. Woodard, M. G. Finn, Sel., Goal Synth. Effic., Proc. Workshop Conf. Hoechst, 14th, 377 (1984).
690. K. B. Sharpless, S. S. Woodard, M. G. Finn, Pure Appl. Chem., 55, 1823 (1983).
691. M. J. Farrall, M. Alexis, M. Trecarten, Nouv. J. Chim., 7, 449 (1983).
692. B. Wu, L. Zhang, W. Zhou, Youji Huaxue, 440 (1983).
693. B. E. Rossiter, K. B. Sharpless, J. Org. Chem., 49, 3707 (1984).
694. L. D. L. Lu, R. A. Johnson, M. G. Finn, K. B. Sharpless, J. Org. Chem., 49, 731 (1984).
695. J. K. Cha, W. J. Christ, Y. Kishi, Tetrahedron, 40, 2247 (1984).
696. F. Porta, M. Pizzotti, G. La Monica, L. A. Finessi, S. Cenini, Congr. Naz. Chim. Inorg. (Atti), 16th, 63 (1983).
697. D. Mansudy, J. P. Mahy, A. Deireault, G. Bedi, P. Battioni, J. Chem. Soc., Chem. Comm., 1161 (1984).
698. J-E. Dubois, G. Axiotis, Tetrahedron Lett., 25, 2143 (1984).
699. L. S. Liebeskind, M. E. Welker, V. Goedken, J. Am. Chem. Soc., 106, 441 (1984).
700. K. Broadley, S. G. Davies, Tetrahedron Lett., 25, 1743 (1984).
701. A. M. Horton, D. M. Hollinshead, S. V. Ley, Tetrahedron, 40, 1737 (1984).



702. S. T. Hodgson, D. M. Hollinshead, S. V. Ley, J. Chem. Soc., Chem. Comm., 495 (1984).
703. E. C. Taylor, H. M. Davies, J. Org. Chem., 49, 113 (1984).
704. H. Mastaberz, J. Org. Chem., 49, 4095 (1984).
705. D. Roberto, H. Alper, Organometallics, 3, 1767 (1984).
706. H. Alper, C. P. Mahatantila, F. W. B. Einstein, A. C. Willia, J. Am. Chem. Soc., 106, 2709 (1984).
707. W. Danzer, R. Hoefer, H. Menzel, B. Olgemoeller, Z. Naturforsch. B: Anorg. Chem., Org. Chem., 39B, 167 (1984).
708. R. Perrone, G. Carbonara, V. Tortorella, Arch. Pharm. (Weinheim, Ger.), 317, 21 (1984).
709. S. Torii, T. Inokuchi, T. Yukawa, Chem. Lett., 1063 (1984).
710. H. Nagashima, H. Wakamatsu, K. Itoh, J. Chem. Soc., Chem. Comm., 652 (1984).
711. G. Lesma, G. Palmisano, S. Tollari, J. Chem. Soc., Perkin I, 1593 (1984).
712. P. A. Kongshaug, Diss. Abstr. Int. B, 45, 1471 (1984).
713. K. Utimoto, Pure Appl. Chem., 55, 1845 (1983).
714. O. Attanasi, P. Filippone, A. Mei, S. Santeusanio, Synthesis, 671 (1984).
715. O. Attanasi, P. Filippone, A. Mei, S. Santeusanio, Synthesis, 872, 874 (1984).
716. B. H. Lipschutz, M. C. Morey, Tetrahedron Lett., 25, 1319 (1984).
717. M. Hugentobler, A. J. Klaus, P. Ruppen, P. Rys, Helv. Chim. Acta, 67, 113 (1984).
718. T. Okamoto, S. Yamamoto, A. Ohno, S. Oka, Bull. Inst. Chem. Res., Kyoto Univ., 61, 64 (1983).
719. R. P. Houghton, M. Boyle, R. Price, J. Chem. Soc., Perkin Trans. I, 925 (1984).
720. A. Saba, Synthesis, 268 (1984).
721. J-i. Yoshida, S. Yano, T. Ozawa, N. Kawabata, Tetrahedron Lett., 25, 2817 (1984).
722. M. S. Shlapak, S. M. Brailovskii, O. N. Temkin, V. B. Frolov, Kinet. Katal., 24, 1375 (1983).
723. M. S. Shlapak, S. M. Brailovskii, O. N. Temkin, Kinet. Katal., 24, 1380 (1983).
724. E. G. Samsel, J. R. Norton, J. Am. Chem. Soc., 106, 5505 (1984).
725. M. S. Carson, L. E. Tully, Proc. R. Ir. Acad., Sect. B, 83B, 33 (1983).
726. N. Ito, H. Nishino, K. Kurosawa, Bull. Chem. Soc., Jpn., 56, 3527 (1983).
727. M. Matsumoto, S. Ito, Synth. Comm., 14, 697 (1984).
728. T. Chakraborty, S. Chandrasekaran, Tetrahedron Lett., 25, 2895 (1984).
729. H. Suzuki, S. V. Thiruvikraman, A. Osuka, Synthesis, 616 (1984).
730. Y. Watanabe, Y. Tsuji, J. Shida, Bull. Chem. Soc., Jpn., 57, 435 (1984).
731. D. L. Boger, J. S. Panek, Tetrahedron Lett., 25, 3175 (1984).

732. K. Suematsu, Chem. Pharm. Bull., 32, 291 (1984).
733. M. Basato, B. Corain, A. Marcomini, G. Valle, G. Zanotti, J. Chem. Soc., Perkin II, 965 (1984).
734. D. Sellmann, L. Zapf, Angew. Chem. Int. Ed., 23, 807 (1984).
735. M. R. Ashcroft, P. Bougeard, A. Bury, C. J. Cooksey, M. D. Johnson, J. M. Hungerford, G. M. Lampman, J. Org. Chem., 49, 1751 (1984).
736. J. Otera, M. Kishi, K. Kanehira, S. Suzuki, M. Shiono, Y. Fujita, Syn. Comm., 14, 347 (1984).
737. A. Carpita, F. Bonaccorsi, R. Rosai, Tetrahedron Lett., 25, 5193 (1984).
738. S-i. Murahashi, T. Tsumiyama, Y. Mitsue, Chem. Lett., 1419 (1984).
739. S. G. Davies, S. E. Thomas, Synthesis, 1027 (1984).
740. J. Muzart, J. P. Pete, Bull. Soc. Chim. Fr. II, 56 (1984).
741. R. Riguera, E. Quinoa, L. Castedo, J. Chem. Soc., Chem. Comm., 1120 (1984).
742. S. Cacchi, E. Morera, G. Ortar, Tetrahedron Lett., 25, 4821 (1984).
743. J. Tsuji, I. Shimizu, I. Minami, Chem. Lett., 1017 (1984).
744. Y. Colas, B. Cazes, J. Gore, Tetrahedron Lett., 25, 845 (1984).
745. S. C. Kao, M. Y. Darensbourg, Organometallics, 3, 646 (1984).
746. E-i. Negishi, J. A. Miller, T. Yoshida, Tetrahedron Lett., 25, 3407 (1984).
747. S. L. Grundy, P. M. Maitlis, J. Organomet. Chem., 272, 265 (1984).
748. J. L. Costa, A. F. Noels, A. J. Hubert, Ph. Teyssie, Tetrahedron Lett., 25, 649 (1984).
749. R. S. E. Conn, M. Karras, B. B. Snider, Isr. J. Chem., 24, 108 (1984).
750. M. E. Krafft, R. A. Holton, J. Am. Chem. Soc., 106, 7619 (1984).
751. M. E. Krafft, R. A. Holton, J. Org. Chem., 49, 3669 (1984).
752. M. Kosugi, T. Ohya, T. Migita, Bull. Chem. Soc., Jpn., 56, 3539 (1983).
753. H. Felkin, T. Fillebeen-Khan, Y. Gault, R. Holmes-Smith, J. Zakrzewski, Tetrahedron Lett., 25, 1279 (1984).
754. D. Baudry, M. Ephritikhine, H. Felkin, J. Zakrzewski, Tetrahedron Lett., 25, 1283 (1984).
755. M. Tanaka, T-a. Kobayashi, T. Sakakura, Angew. Chem. Int. Ed., 23, 518 (1984).
756. Y. Tsuji, T. Ohta, T. Ido, H. Minbu, Y. Watanabe, J. Organomet. Chem., 270, 333 (1984).
757. T. Okamoto, K. Sasaki, S. Oka, Chem. Lett., 1247 (1984).
758. J. Martin, C. Martin, M. Faraj, J. M. Bregeault, Nouv. J. Chim., 8, 141 (1984).
759. R. Irie, X. Li, Y. Saito, J. Mol. Catal., 23, 17 (1984).
760. B. M. Trost, Y. Masuyama, Tetrahedron Lett., 25, 173 (1984).
761. F. H. Mussein, G. Pattenden, R. Rudhan, J. J. Russell, Tetrahedron Lett., 25, 3363 (1984).
762. M. F. Semmelhack, C. R. Schmid, D. A. Cortes, C. S. Chow, J. Am. Chem. Soc., 106, 3374 (1984).
763. M. Matsumoto, N. Watanabe, J. Org. Chem., 49, 3437 (1984).

764. K. S. Kirshenbaum, Nouv. J. Chim., 7, 699 (1983).
765. A. M. Maione, A. Romeo, Synthesis, 955 (1984).
766. J. Tsuji, Synthesis, 369 (1984).
767. D. Dimitrov, V. Sirakova, V. Angelov, R. Stefanova, Khim. Ind. (Sofia), 56, 54 (1984).
768. V. Sirakova, D. Dimitrov, V. Angelov, Dokl. Bolg. Akad. Nauk, 37, 767 (1984).
769. S. F. Davison, B. E. Mann, P. M. Maitlis, J. Chem. Soc., Dalton, 1223 (1984).
770. Y. Izumi, Y. Fujii, K. Urabe, J. Catal., 85, 284 (1984).
771. M. A. Andrews, T. C. T. Chang, C. W. F. Cheng, T. J. Emge, K. P. Kelly, T. F. Koetzle, J. Am. Chem. Soc., 106, 5913 (1984).
772. F. Mares, S. E. Diamond, Fundam. Res. Homogeneous Catal., 4, 55 (1984).
773. O. Bortolini, F. Di Furia, G. Modena, R. Seraglia, J. Mol. Catal., 22, 313 (1984).
774. R. B. Gammill, S. A. Nash, Tetrahedron Lett., 25, 2953 (1984).
775. A. J. Pearson, Y. S. Chen, S. Y. Hsu, T. Ray, Tetrahedron Lett., 25, 1235 (1984).
776. T. Sudhakara Rao, H. H. Mathur, G. K. Trivedi, Tetrahedron Lett., 25, 5561 (1984).
777. I. V. Spirina, V. P. Sergeeva, V. P. Maslennikov, Y. A. Aleksandrov, G. A. Razuvaev, Dokl. Akad. Nauk SSSR, 272, 1138 (1983).
778. M. P. Doyle, J. W. Terpstra, C. H. Winter, J. H. Griffin, J. Mol. Catal., 26, 259 (1984).
779. J. Vymetal, J. Norek, V. Cermak, Chem. Prum., 34, 467 (1984).
780. X. Y. Wang, R. J. Motekaitis, Inorg. Chem., 23, 271 (1984).
781. M. Nitta, T. Kobayashi, J. Chem. Soc., Perkin Trans. I, 2103 (1984).
782. O. Toussaint, P. Capdevielle, M. Maumy, Tetrahedron Lett., 25, 3819 (1984).
783. R. Bertani, C. B. Castellani, B. Crociani, J. Organomet. Chem., 269, C15 (1984).
784. M. Nitta, I. Susaki, H. Miyano, T. Kobayashi, Bull. Chem. Soc. Jpn., 57, 3357 (1984).
785. O. Attanasi, M. Grossi, F. Serra-Zanetti, J. Chem. Res., Synop, 322 (1983).
786. P. Laszlo, E. Polla, Tetrahedron Lett., 25, 3309 (1984).
787. M. Balogh, A. Cornelis, P. Laszlo, Tetrahedron Lett., 25, 3313 (1984).
788. G. Carnelli, F. Manescalchi, A. Umani-Ronchi, J. Organomet. Chem., 276, 205 (1984).
789. P. L. Gaus, S. C. Kao, M. Y. Darensborg, L. W. Arndt, J. Am. Chem. Soc., 106, 4752 (1984).
790. N. A. Moldavskaya, L. V. Krysenko, N. K. Skvortsov, V. O. Reikhsfel'd, Kremniorg. Soedin. Mater. Ikh Osn., Tr. Soveshch. Khim. Prakt. Primen. Kremniorg, Soedin, 5th, 53 (1984).

791. T. Hayashi, K. Kaheta, M. Kumada, Tetrahedron Lett., **25**, 1499 (1984).
792. A. Millan, M. J. Fernandez, P. Bentz, P. M. Maitlis, J. Mol. Catal., **26**, 89 (1984).
793. H. Brunner, B. Reiter, G. Riepl, Chem. Ber., **117**, 1330 (1984).
794. M. F. Lappert, R. K. Maskell, J. Organomet. Chem., **264**, 217 (1984).
795. H. Brunner, R. Becker, Angew. Chem. Int. Ed., **23**, 222 (1984).
796. H. Urata, H. Suzuki, Y. Moro-oka, T. Ikawa, Bull. Chem. Soc. Jpn., **57**, 607 (1984).
797. H. Killing, T. N. Mitchell, Organometallics, **3**, 1318 (1984).
798. M. Kosagi, T. Ohya, T. Migita, Bull. Chem. Soc. Jpn., **56**, 385 (1983).
799. J-i. Hibino, S. Matsubara, Y. Morizawa, K. Oshima, Tetrahedron Lett., **20**, 2151 (1984).
800. H. Oda, Y. Morizawa, K. Oshirma, H. Nozaki, Tetrahedron Lett., **25**, 3217 (1984).
801. Y. Tsukahara, H. Kinoshita, K. Inomata, H. Kotake, Bull. Chem. Soc. Jpn., **57**, 3013 (1984).
802. M. A. Andrews, T. C. T. Chang, C. W. F. Cheng, L. V. Kapustay, K. P. Kelly, M. J. Zweifel, Organometallics, **3**, 1479 (1984).
803. T. Okamoto, S. Oka, J. Chem. Soc., Chem. Comm., 289 (1984).
804. O. Attanasi, P. Filippone, P. Ballistoni, G. Fava, Synthesis, 422 (1984).
805. J. Casado, M. Mosquera, M. F. Rodriguez Prieto, T. Vazquez, Acta Cient. Compostelana, **19**, 109 (1982).
806. H. Mitsui, S-i. Zenki, T. Shiota, S-i. Murahashi, J. Chem. Soc., Chem. Comm., 874 (1984).
807. S. K. Tyrlik, A. Korda, A. Rockenbauer, J. Mol. Catal., **22**, 79 (1983).
808. J. D. Baleja, Synth. Comm., **14**, 215 (1984).
809. T. Takeda, T. Tsuchida, T. Fujiwara, Chem. Lett., 1219 (1984).
810. M. Kijima, Y. Nambu, T. Endo, M. Okawara, J. Org. Chem., **49**, 1434 (1984).
811. P. Pitchen, H. B. Kagan, Tetrahedron Lett., **25**, 1049 (1984).
812. F. Gasparrini, M. Giovannoli, D. Misiti, G. Natile, G. Palmieri, Tetrahedron, **39**, 3181 (1983).
813. K. Osakada, K. Matsumoto, T. Yamamoto, A. Yamamoto, Chem. Ind. (London), 634 (1984).
814. G. P. Boldrini, D. Savoia, E. Tagliavini, C. Trombini, A. Umani-Ronchi, J. Organomet. Chem., **268**, 97 (1984).
815. N. Kamigata, T. Narushima, H. Sawada, M. Kobayashi, Bull. Chem. Soc. Jpn., **57**, 1421 (1984).
816. O. Attanasi, Chim. Ind. (Milan), **66**, 19 (1984).
817. S. Murahashi, T. Naota, Kagaku (Kyoto), **39**, 275 (1984).
818. T. Bartik, P. Heimbach, H. Schenkluhn, K. Tani, Kontakte (Darmstadt), 44 (1984).

819. S. V. Ley, R. A. Porter, P. F. Gordon, A. J. Nelson, Gen. Synth. Methods, 6, 218 (1983).
820. L. S. Hegedus, J. Organomet. Chem., 261, 283 (1984).
821. L. S. Hegedus, Stud. Org. Chem. (Amsterdam), 5B, 1 (1984).
822. T. Bartik, P. Heimbach, P. Ndalut, H. G. Preis, H. Schenkluhn, H. Sturm, Kontakte (Darmstadt), 14 (1983).
823. J. Tsuji, Shokubai, 25, 451 (1983).
824. R. Scheffold, G. Rytz, L. Walder, R. Orlinksí, Z. Chilmonczyk, Pure Appl. Chem., 55, 1791 (1983).
825. X. Lu, Youji Huaxue, 293 (1983).
826. B. L. Shapiro, "Organometallic Compounds: Synthesis, Structure, and Theory", Texas A & M University Press, College Station, Texas (1983).
827. J. M. Basset, A. Choplin, J. Mol. Catal., 21, 95 (1983).
828. Y. I. Ermakov, J. Mol. Catal., 21, 35 (1983).
829. M. E. Thompson, J. E. Bercaw, Pure Appl. Chem., 56, 1 (1984).
830. A. H. Janowicz, R. A. Periana, J. M. Buchanan, C. A. Kovac, J. M. Stryker, M. J. Wax, R. G. Bergman, Pure Appl. Chem., 56, 13 (1984).
831. J. C. Hayes, P. Jernakoff, G. A. Miller, N. J. Cooper, Pure Appl. Chem., 56, 25 (1984).
832. J. J. Eisch, Pure Appl. Chem., 56, 35, (1984).
833. M. L. H. Green, Pure Appl. Chem., 56, 47 (1984).
834. P. B. Mackenzie, K. C. Ott, R. H. Grubbs, Pure Appl. Chem., 56, 59 (1984).
835. K. Jonas, Pure Appl. Chem., 56, 63 (1984).
836. S. A. R. Knox, Pure Appl. Chem., 56, 81 (1984).
837. A. Alexakis, C. Chuit, M. Commercon-Bourgain, J. P. Foulon, N. Jabri, P. Mangeney and J. F. Normant, Pure Appl. Chem., 56, 91 (1984).
838. I. Ojima, Pure Appl. Chem., 56, 99 (1984).
839. G. A. Ozin, J. G. McCaffrey, D. F. McIntosh, Pure Appl. Chem., 56, 111 (1984).
840. M. Rosenblum, A. Bucheister, T. C. T. Chang, M. Cohen, M. Marsi, S. B. Samuels, D. Scheck, N. Sofen, J. C. Watkins, Pure Appl. Chem., 56, 129 (1984).
841. L. Marko, J. Organomet. Chem., 261, 485 (1984).
842. L. A. P. Kane-Maguire, Mech. Inorg. Organomet. React., 2, 301 (1984).
843. D. M. Roundhill, Homogeneous Catal. Met. Phosphine Complexes, 377 (1983).
844. H. D. Hodes, Diss. Abstr. Int. B, 44, 1456 (1983).
845. H. G. Alt, Angew. Chem. Int. Ed., 23, 766 (1984).
846. M. L. Steigerwald, Diss. Abstr. Int. B, 45, 1200 (1984).
847. I. I. Moisseev, Ref. Zh. Khim., (1984).
848. R. S. Dickson, "Organometallic Chemistry of Rhodium and Iridium", Academic Press, London, UK, (1983).
849. Y. Kurusu, Hyomen, 22, 155 (1984).
850. H. Schumann, Angew. Chem. Int. Ed., 23, 474 (1984).

851. U. Schubert, Coord. Chem. Rev., 55, 261 (1984).
852. H. C. Clark, U. K. Jain, Coord. Chem. Rev., 55, 151 (1984).
853. B. A. Dolgoplosk, Russ. Chem. Rev., 52, 613 (1983).
854. S. K. Grigoryan, Russ. Chem. Rev., 52, 532 (1983).
855. I. S. Akhrem, N. M. Chistoualova, M. E. Vol'pin, Russ. Chem. Rev., 52, 542 (1982).
856. H. M. Colquhoun, Acc. Chem. Res., 17, 23 (1984).
857. K. A. Belmore, Diss. Abstr. Int. B, 45, 1462 (1984).
858. J. R. Moss, L. G. Scott, Coord. Chem. Rev., 60, 171 (1984).
859. V. Galamb, G. Palyi, Coord. Chem. Rev., 59, 203 (1984).
860. A. Segnitz, "Houben-Weyl Methods of Organic Chemistry", Vol. 13, Pt. 9B (1984).
861. M. L. H. Green, Chem. Uses Molybdenum, Proc. Int. Conf., 4th, 74 (1982).
862. H. Hirai, M. Komiyama, Yuki Gosei Kagaku Kyotaishi, 42, 32 (1984).
863. R. W. Zoellner, K. J. Klabunde, Chem. Rev., 84, 545 (1984).
864. B. Meumer, Bull. Soc. Chim., France, II-345 (1983).
865. F. Minisci, Fundam. Res. Homogeneous Catal., 4, 173 (1984).
866. M. R. White, Diss. Abstr. Int. B, 44, 1129 (1983).
867. S. P. Gubin, A. V. Golounin, Nauka, Sibirskoe Otdelenie: Novosibirsk, USSR, 202 (1983).
868. E. G. Perevalova, M. D. Reshetova, K. I. Grandberg, Nauka: Moscow, USSR, 544 (1983).
869. B. Bosnich, Chem. Br., 20, 808 (1984).
870. S. G. Davies, J. I. Seeman, Tetrahedron Lett., 25, 1845 (1984).
871. V. I. Sokolov, Pure Appl. Chem., 55, 1837 (1983).
872. J. Weishaepfl, Oesterr. Chem., Z., 85, 1 (1984).
873. B. Fell, G. Maletz, J. Mol. Catal., 22, 373 (1984).
874. R. Sariego Badal, Contrib. Cient. Tecnol., 14, 53 (1984).
875. J. Halpern, Ann. N. Y. Acad. Sci., 415, 244 (1983).
876. D. Milstein, Acc. Chem. Res., 17, 221 (1984).
877. J. P. Orchard, A. D. Tomsett, M. S. Wainwright, D. J. Young, J. Catal., 84, 189 (1983).
878. K. Itoh, Kagaku Kyoiku, 31, 426 (1983).
879. B. Meunier, Bull. Soc. Chim. Fr., 345 (1983).
880. L. S. Hegedus, Tetrahedron, 40, 2415 (1984).
881. H. Larraza, Rev. Soc. Quim. Mex., 27, 184 (1983).
882. T. Mukaiyama, Isr. J. Chem., 24, 162 (1984).
883. T. Mukaiyama, Pure Appl. Chem., 55, 1749 (1983).
884. R. R. Chianelli, NATO ASI Ser., Ser. C, 105 (1983).

885. V. A. Kabanov, V. I. Smetanyuk, Itogi Nauki i Tekhn, VINITI. Kinet. i Kataliz., 213 (1984).
886. H. Alper, Fundam. Res. Homogeneous Catal., 4, 79 (1984).
887. J. A. Gladysz, Acc. Chem. Res., 17, 326 (1984).
888. M. Orchin, Catal. Rev.-Sci. Eng., 26, 59 (1984).
889. K. Takai, H. Nozaki, Kagaku (Kyoto), 38, 596 (1983).
890. J. P. Loh, Diss. Abstr. Int. B, 44, 1121 (1983).