

COMPLEXES CONTAINING HETERONUCLEAR METAL-METAL BONDS.  
SOME RECENT ADVANCES 1980-81

B.\* HETEROMETALLIC CLUSTER COMPLEXES

Michael I. Bruce

*Jordan laboratories, Department of Physical and Inorganic Chemistry,  
University of Adelaide, South Australia 5001.*

INTRODUCTION

In this, the second part of a survey of advances in the chemistry of compounds containing bonds between two or more different transition metals I concentrate on advances in the chemistry of mixed-metal clusters. Although nominally restricted to the period 1980-81, an excellent review article [1] covers the literature to approximately the beginning of this period, and I have attempted to continue the survey from the cut-off point in that survey. As mentioned in the earlier part, a complete account of complexes of the type reviewed here has appeared in *Comprehensive Organometallic Chemistry* [2].

The definition of "cluster complex" used below is the commonly accepted one of those compounds containing a metal core which has three or more atoms; however in the case of  $M_3$  or  $M_4$  cores, I have included a few compounds with bent metal sequences, although the majority have at least one triangular face.

General advances      One of the most influential advances in organo-metallic chemistry has been the recognition of the isolobal relationships between various metal-ligand fragments and the more well-known organic CH,

---

\* For Part A, see *J.Organomet.Chem.*, 242 (1983) 147.

CH<sub>2</sub> or CH<sub>3</sub> groups. These have been detailed in Part A, and in a remarkably fruitful period, their application to the synthesis of a variety hetero-bi- and tri-metallic complexes by Stone and coworkers has resulted in a rapid expansion of our knowledge of these complexes. This subject has been comprehensively reviewed [3,4]. In the present context, a particularly useful comparison has been that between the  $\equiv\text{CH}$  and  $\equiv\text{W}(\text{CO})_2(\eta\text{-C}_5\text{H}_5)$  fragments, which leads to the following formal relationships:

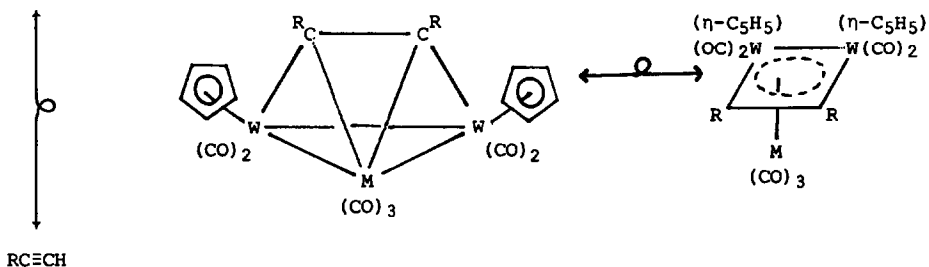
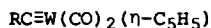

During the period under review, the synthesis of many heterometallic clusters, while achieved by reactions designed to produce complexes containing heterometallic bonds, was largely accidental in that the precise nature of the products was unpredictable. Nevertheless, significant advances were made by several groups, among which should be mentioned the controlled build-up of metal clusters using Main Group atoms as linkage points, and the addition of coordinatively unsaturated metal fragments [generated from  $\text{Pt}(\eta\text{-C}_2\text{H}_4)_3$  or photochemically] to metal-metal multiple bonds. In the course of this work, the utility of  $\text{Pt}(\eta\text{-C}_2\text{H}_4)_2(\text{PR}_3)$  in removing CO from coordinatively saturated metal carbonyls with concomitant incorporation of the  $\text{Pt}(\text{CO})(\text{PR}_3)$  fragment in the resulting clusters, and the 16-electron configuration of Pt in tetranuclear clusters, were recognised [5,6]. A consequence of the latter observation is that formally analogous Ni- and Pt-containing clusters have tetrahedral and butterfly arrangements of the  $\text{M}_4$  core, respectively.

One of the most detailed investigations of mixed-metal clusters is that of Geoffroy and his group into the synthesis, structure and properties

of complexes containing the Fe-Ru-Os triad of elements. More recently these studies have encompassed the structures, molecular dynamics and reactions of  $H_2M_4(CO)_{13}$  and derived compounds, and much of this work has been reviewed [7,8]. Worthy of mention, too, is the Italian work on larger heteroatom clusters, including the  $Fe_4Pt_6$  and  $Fe_6Pt_6$  fragments, studies on a variety of mixed-metal systems formed by metal-hydride coupling, a whole range of mixed-metal carbide clusters, the extensive work on hydrocarbon (mainly alkyne)-bridged clusters, and the resolution of the first tetrahedral cluster which is chiral by virtue of its having four different framework atoms. In late 1981 came also the recognition of the complementary relationship between H and the  $Au(PR_3)$  moieties which has led to a rapid development of the chemistry of heterometal clusters containing a Group IB metal. We have also devoted a small section to summarising the rapid and exciting progress being made towards the understanding of the nitrogenase system and studies of  $MoFe_3S_4$ -cubane complexes and other polynuclear thiometalate derivatives.

This complex area of new chemistry has been surveyed under the following headings, such a sequence leading to the least duplication and fragmentation of coverage:

- Heteronuclear metal cluster carbonyls and their derivatives
  - with donor ligands ( $PR_3$ ,  $AsR_3$ , acac, etc.)
- Heteronuclear metal cluster carbonyls containing  $\eta$ -cyclopentadienyl ligands
- Heteronuclear metal carbide clusters
- Heteronuclear metal clusters containing Group IB metals
- Heterometallic cluster complexes containing bridging carbene, alkylidyne, alkyne or related ligands
- Heterometallic cluster complexes containing bridging P-donor, S-donor or halogen ligands ( $\mu$ - $PR_2$ ,  $\mu$ - $SMe$ ,  $\mu_3$ - $PR$ ,  $\mu_3$ - $S$ , etc.)
- Sulphur-bridged clusters of biological interest, and related thiometalate complexes

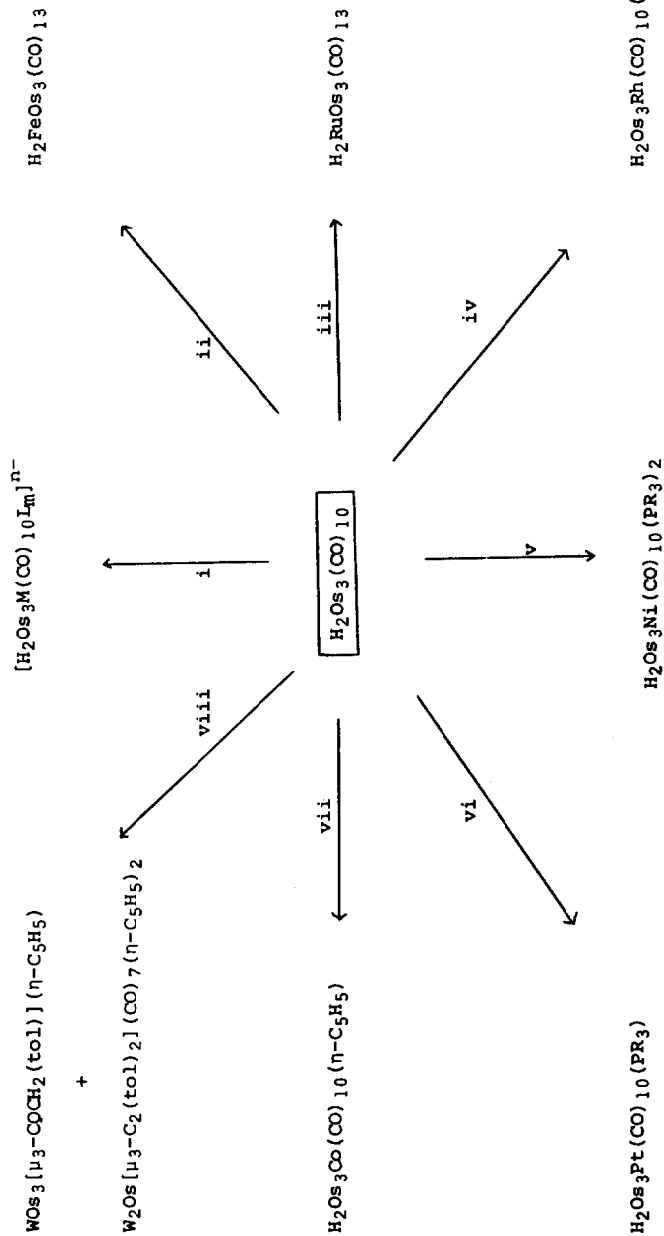
SCHEME 1 Syntheses of some heteronuclear metal clusters from  $\text{H}_2\text{Os}_3(\text{CO})_{10}$ 

Reagents: i,  $[\text{ML}_m]^{n-}$  ( $[\text{V}(\text{CO})_3(\eta\text{-C}_5\text{H}_5)]^{2-}$ ,  $[\text{Mo}(\text{CO})_3(\eta\text{-C}_5\text{H}_5)]^{-}$ ,  $[\text{Mn}(\text{CO})_5]^{-}$ ,  $[\text{Fe}(\text{CO})_4]^{2-}$ ,  $[\text{Fe}(\text{CO})_2(\eta\text{-C}_5\text{H}_5)]^{-}$ );

ii,  $\text{Fe}(\text{CO})_5 + \text{h}\nu$ ,  $\text{Fe}_2(\text{CO})_9$ , or  $[\text{Fe}(\text{CO})_4]^{2-}$  then  $\text{H}^+$ ; iii,  $\text{Ru}_3(\text{CO})_{12}$ ; iv,  $\text{Rh}(\eta\text{-C}_2\text{H}_4)_2(\text{acac})$ ; v,  $\text{Ni}(\eta\text{-C}_2\text{H}_4)(\text{PR}_3)_2$ ; vi,  $\text{Pt}(\eta\text{-C}_2\text{H}_4)_2(\text{PR}_3)$ ; vii,  $\text{Co}(\text{CO})_2(\eta\text{-C}_5\text{H}_5)$ ; viii,  $\text{W}[\text{C}(\text{tol})](\text{CO})_2(\eta\text{-C}_5\text{H}_5)$ .

Other complexes containing heteronuclear clusters, including mixed metallocarborane, and mixed metal atom clusters.

The final section summarises X-ray studies of heterometallic clusters, most of which were essential for determining the molecular geometries of the complexes discussed in the preceding sections.

Complexes obtained from  $\text{H}_2\text{Os}_3(\text{CO})_{10}$  The high reactivity and ready availability of the "unsaturated" complex  $\text{H}_2\text{Os}_3(\text{CO})_{10}$  has made it a reagent of choice for the synthesis of mixed-metal clusters by addition of suitable substrates. These reactions are summarised in Scheme 1, although detailed discussion of most of the complexes is given in the appropriate parts of the following Sections.

Several anionic mixed metal clusters have been prepared by simple addition of anionic metal carbonyls to  $\text{H}_2\text{Os}_3(\text{CO})_{10}$ ; all are considered to have the same basic structure (1) in which the entering metal-ligand moiety forms a simple Os-M bond, and is not incorporated into a larger heterometallic cluster [9]. The complexes generally decompose within an hour, although the bright yellow  $\text{MnOs}_3$  complex could be isolated in 75% yield.

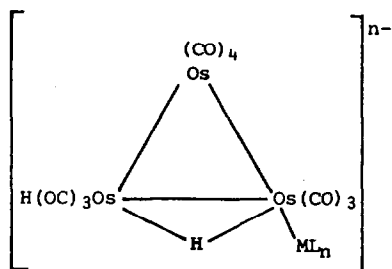

(1)

$\text{ML}_n = \text{V}(\text{CO})_3(\eta\text{-C}_5\text{H}_5)$	$n = 2$
$\text{Mo}(\text{CO})_3(\eta\text{-C}_5\text{H}_5)$	1
$\text{Mn}(\text{CO})_5$	1
$\text{Fe}(\text{CO})_4$	2
$\text{Fe}(\text{CO})_2(\eta\text{-C}_5\text{H}_5)$	1

## 1. HETERONUCLEAR METAL CLUSTER CARBONYLS AND THEIR DERIVATIVES WITH 2e-DONOR LIGANDS

W-Ni Thermal or photolytic reactions between  $[\text{ppn}]_2[\text{Ni}_6(\text{CO})_{12}]$  and  $\text{W}(\text{CO})_5(\text{thf})$  (prepared *in situ*) afford the known  $[\text{ppn}]_2[\text{W}_2\text{Ni}_3(\text{CO})_{16}]$  (68%). However, reaction at  $0^\circ\text{C}$  affords red  $[\text{ppn}]_2[\text{WNi}_6(\text{CO})_{17}]$  (2) (38%); similar anions were formed with the Cr and Mo analogues, but not isolated [10].

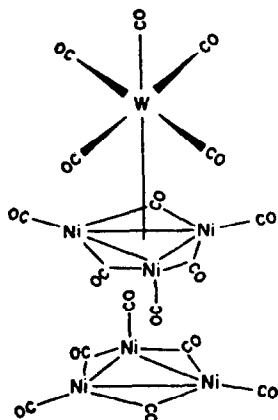

(2)

Re-Os      Addition of  $\text{HRe}(\text{CO})_5$  to  $\text{Os}_3(\text{CO})_{12-n}(\text{NCMe})_n$  ( $n = 1, 2$ ) affords  $(\mu\text{-H})_n\text{Os}_3(\text{CO})_{12-n}[\text{Re}(\text{CO})_5]_n$  [11]. Heating  $(\mu\text{-H})_2\text{Re}_2\text{Os}_3(\text{CO})_{20}$  in acetonitrile results in quantitative conversion to  $(\mu\text{-H})\text{ReOs}_3(\text{CO})_{15}(\text{NCMe})$  (3) [originally reported to be  $\text{HReOs}_3(\text{CO})_{15}$ ], by elimination of the  $\text{Re}(\text{CO})_5$  group *trans* to a  $\mu\text{-H}$  ligand [12]. The structure consists of an  $\text{Os}_3$  triangle, with one axial site being occupied by  $\text{MeCN}$ , and an equatorial site on an adjacent Os by an  $\text{Re}(\text{CO})_5$  moiety; the H atom bridges the long Os-Os vector [13].

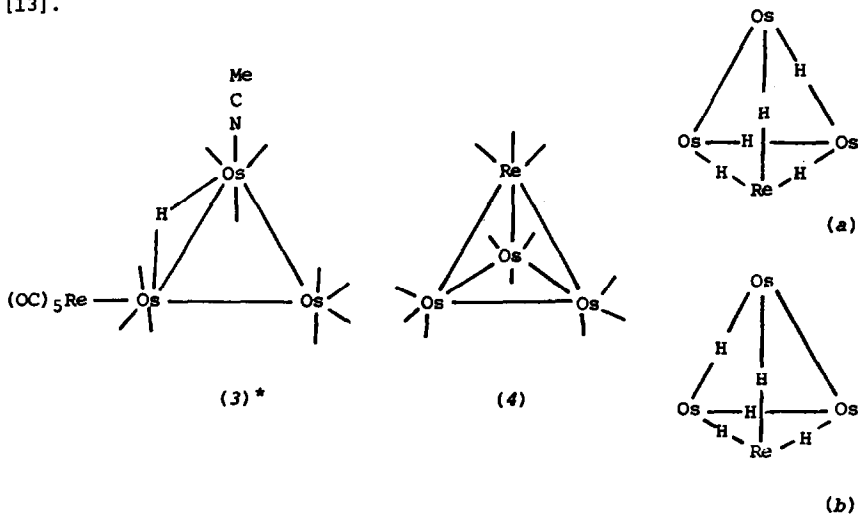

Cluster (3)\* reacts with CO to give  $(\mu\text{-H})\text{ReOs}_3(\text{CO})_{16}$ , and with  $\text{HRe}(\text{CO})_5$  to regenerate  $(\mu\text{-H})_2\text{Re}_2\text{Os}_3(\text{CO})_{20}$ ; on heating in refluxing MeCN in the presence of  $\text{Me}_3\text{NO}$  and  $\text{H}_2$ , pale yellow  $(\mu\text{-H})_5\text{ReOs}_3(\text{CO})_{12}$  (4) is formed [12]. In this reaction, the open  $\text{ReOs}_3$  cluster is converted to a closed tetrahedron. The five H atoms bridge five of the six edges; there is a crystallographic mirror plane, so that the structure is a composite of the two asymmetric molecules (a) and (b).

**Fe-Ru-Os** Reduction of the mixed metal carbonyls  $\text{M}_3(\text{CO})_{12}$  ( $\text{M}_3 = \text{Fe}_2\text{Ru}$ ,  $\text{FeRu}_2$ ) by electrolytic methods or by alkali metals affords radical anions which have been studied by ESR methods at low temperatures [14]. Below 233K, the  $\text{Fe}_2\text{Ru}$  radical anion gives a sharp ESR signal at  $g = 1.996$ ; at higher temperatures, rapid decomposition gives a new paramagnetic species ( $g = 2.051$ ). The  $\text{FeRu}_2$  anion similarly gives a narrow signal ( $g = 1.990$ ) below 213K.

Standard enthalpies of formation,  $\Delta H_f^\circ$ , of  $\text{Fe}_2\text{Ru}(\text{CO})_{12}$ ,  $\text{FeRu}_2(\text{CO})_{12}$  and  $\text{Ru}_3(\text{CO})_{12}$  have been determined as  $-(1820 \pm 14)$ ,  $-(1891 \pm 16)$  and  $-(1903 \pm 18)$   $\text{kJ mol}^{-1}$ , respectively; the Fe-Ru bond enthalpy contribution is ca  $95 \pm 20$   $\text{kJ mol}^{-1}$  [15].

Comparative high-resolution infrared and Raman  $\nu(\text{CO})$  spectra of  $\text{Ru}_n\text{Os}_{3-n}(\text{CO})_{12}$  ( $n = 0-3$ ) have been described [16]. Although the average CO stretching force constant has the same value ( $16.66 \text{ mdyn \AA}^{-1}$ ) for each compound, individual axial and equatorial CO stretching force constants are characteristic of the metal atom. Since vibrational coupling between CO

---

\* In this and many others of the structural formulas, terminal CO groups are represented by lines extending from the metal atom to which they are bonded.

groups on different metal atoms is significant, a local symmetry analysis of the  $\nu(\text{CO})$  spectra is inappropriate. Detailed instructions for the separation of  $\text{RuOs}_2(\text{CO})_{12}$  and  $\text{Ru}_2\text{Os}(\text{CO})_{12}$  (prepared by heating  $\text{Ru}_3(\text{CO})_{12}$  with  $\text{Os}_3(\text{CO})_{12}$  in xylene, or from  $[\text{RuCl}_2(\text{CO})_3]_2$ ,  $\text{OsO}_4$  and  $\text{CO}$  under pressure) are given. The  $^{13}\text{C}$  NMR spectrum of  $\text{RuOs}_2(\text{CO})_{12}$  exhibits two signals in the ratio 5:1 at  $30^\circ\text{C}$ , which coalesce at  $70^\circ\text{C}$ , and are replaced by a single resonance at  $145^\circ\text{C}$ . The fluxional process indicated is suggested to occur via an intermediate in which two CO groups bridge the Ru-Os bond, while two CO groups *trans* to the Os-Os bond do not exchange [17].

A brief report mentions the reaction of  $\text{Fe}_2(\text{CO})_9$  with  $\text{Os}_5(\text{CO})_{19}$  to give  $\text{Fe}_2\text{Os}_5(\text{CO})_{21}$  [18].

What is probably the most detailed investigation of mixed-metal clusters is that of Geoffroy and coworkers into the synthesis, structures and properties of tetranuclear clusters containing metals of the Fe-Ru-Os triad. Reactions between  $[\text{ppn}][\text{HFe}(\text{CO})_4]$  and  $\text{Ru}_3(\text{CO})_{12}$  or  $\text{Fe}_2\text{Ru}(\text{CO})_{12}$  afford the cluster anions  $[\text{HFeRu}_3(\text{CO})_{13}]^-$  (5) and  $[\text{HFe}_2\text{Ru}_2(\text{CO})_{13}]^-$  (6), respectively, in 47 and 4% yield [19]. In contrast with  $[\text{HFe}_4(\text{CO})_{13}]^-$ , which has an unusual CO ligand acting as a 4-electron donor to the  $\text{Fe}_4$  butterfly core, (5) and (6) have distorted tetrahedral  $\text{M}_4$  cores. In (5), two of the CO groups on Fe semi-bridge Fe-Ru vectors, while in (6), a single CO ligand symmetrically bridges the Fe-Fe bond. A neutron diffraction study of (5) located the H atom bridging the long Ru-Ru edge. In both complexes, the  $\text{Fe}(\text{CO})_4$  moiety is tilted relative to the  $\text{M}_3$  basal plane.

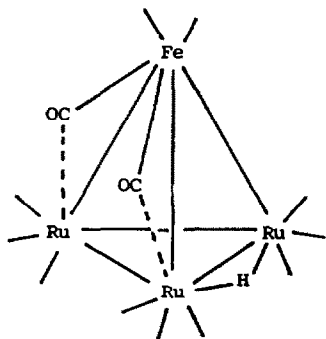

(5)

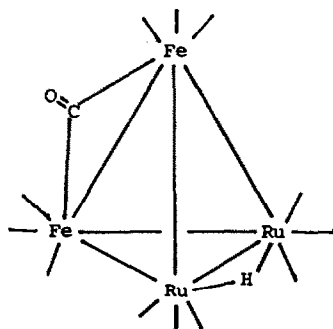

(6)



Three distinct fluxional processes are revealed by the variable temperature  $^1\text{H}$  and  $^{13}\text{C}$  NMR studies of  $\text{H}_2\text{FeRu}_3(\text{CO})_{13}$  (7),  $\text{H}_2\text{FeRu}_2\text{Os}(\text{CO})_{13}$  (8) and  $\text{H}_2\text{FeRuOs}_2(\text{CO})_{13}$  (9) [20]. The osmium-containing clusters exist as readily interconvertible  $C_1$  and  $C_S$  isomers in solution; isomerisation (Scheme 2) has

SCHEME 2 Isomerisation of Fe-Ru-Os hydrido-carbonyl clusters

(a) Bridge-terminal CO interchange

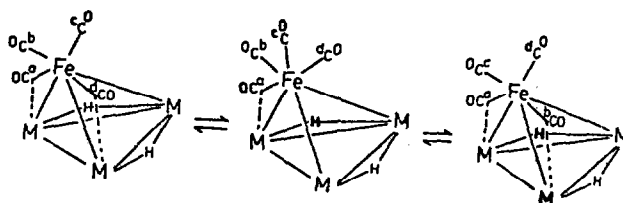

(b) Cyclic movement of CO groups about an  $\text{FeM}_2$  face

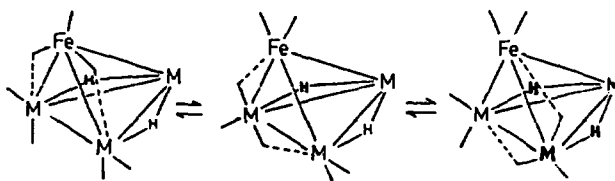

(c) Metal framework shift

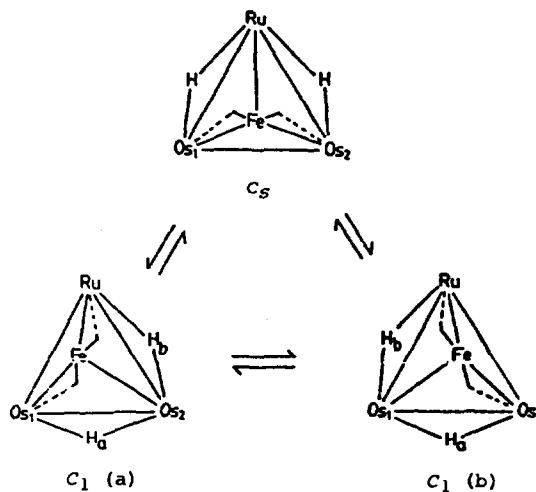

a lower activation energy (14.2, 17.1 kcal mol<sup>-1</sup>) than H exchange localised on the C<sub>1</sub> isomer (15.4, 17.5 kcal mol<sup>-1</sup>, respectively). The low-temperature limiting <sup>13</sup>C NMR spectrum of (7) is obtained at -95°; on warming, bridge-terminal interchange localised on Fe is observed, followed by a cyclic movement of CO groups around the FeRu(1)Ru(2) face, beginning at -65°. The final process, which begins at -45°, is proposed to occur by a shift in the metal framework, specifically of Fe closer to Ru(3) and away from Ru(1). This process, which requires only a change of ca 0.1 Å in the metal-metal separations, is considered to be a breathing motion coupled to motions of the CO and H ligands. It allows the two enantiomers of the C<sub>1</sub> isomers of (8) and (9) to interconvert, and also the C<sub>S</sub> ⇌ C<sub>1</sub> isomerisation. Similar processes occur with (8) and (9); the <sup>13</sup>C NMR spectra are complicated by presence of the two isomers. As the Os content increases, the activation energy for each process also increases.

UV irradiation of H<sub>2</sub>FeRu<sub>3</sub>(CO)<sub>13</sub> or H<sub>2</sub>FeOs<sub>3</sub>(CO)<sub>13</sub> in the presence of H<sub>2</sub> affords H<sub>4</sub>FeRu<sub>3</sub>(CO)<sub>12</sub> and H<sub>4</sub>FeOs<sub>3</sub>(CO)<sub>12</sub>, respectively [21]. The tetrahydrides are thermally unstable; the FeRu<sub>3</sub> complex decomposes to H<sub>4</sub>Ru<sub>4</sub>(CO)<sub>12</sub>, while the FeOs<sub>3</sub> cluster is even less stable, giving a complex mixture of products.

Tetranuclear mixed-metal clusters rapidly fragment, generally to a pair of mononuclear and trinuclear complexes, under CO (1 atm) and mild temperatures [22]. The monomeric fragment contains the first-row transition metal, and the products are consistent with cleavage of the weakest metal-metal bonds. The following reactions were identified:

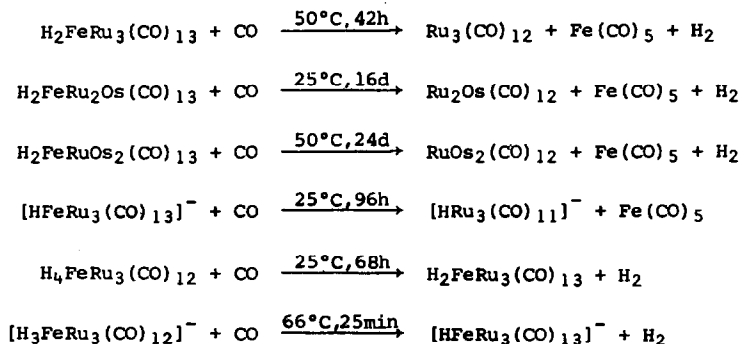

Kinetic data are consistent with the rate law:

$$-d[\text{cluster}]/dt = \{k_1 + k_2[\text{CO}]\}[\text{cluster}]$$

This, in conjunction with the measured activation parameters, suggests the first step to be associative:

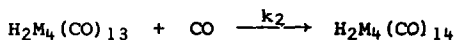

in which one of the M-M bonds in the tetrahedral core is cleaved to give a butterfly cluster.

These reactions are the reverse of well-established substitutions of CO by H<sub>2</sub> to give polyhydrido complexes, such as the reaction between H<sub>2</sub>FeRu<sub>3</sub>(CO)<sub>13</sub> and H<sub>2</sub> to give H<sub>4</sub>FeRu<sub>3</sub>(CO)<sub>12</sub> [23]; indeed, this reaction was used to prepare the [H<sub>3</sub>FeRu<sub>3</sub>(CO)<sub>12</sub>]<sup>-</sup> anion from [HFeRu<sub>3</sub>(CO)<sub>13</sub>]<sup>-</sup> in the work under review. Application of the cluster fragmentation reaction to the separation of Ru<sub>2</sub>Os(CO)<sub>12</sub> and RuOs<sub>2</sub>(CO)<sub>12</sub> is described: these carbonyls, which are mixed with Ru<sub>3</sub>(CO)<sub>12</sub> and Os<sub>3</sub>(CO)<sub>12</sub>, are converted to H<sub>2</sub>FeRu<sub>2</sub>Os(CO)<sub>13</sub> and H<sub>2</sub>FeRuOs<sub>2</sub>(CO)<sub>13</sub>, which can be separated by liquid chromatography, and converted to the Ru<sub>2</sub>Os and RuOs<sub>2</sub> carbonyls by treatment with CO as described above. The fragmentation reactions can be speeded up by broad-band UV (λ > 300 nm) irradiation [21].

The FeRu<sub>3</sub> complex (7) reacts with tertiary phosphines and phosphites to give H<sub>2</sub>FeRu<sub>3</sub>(CO)<sub>13-n</sub>L<sub>n</sub> [L = PPh<sub>3</sub>, PMePh<sub>2</sub>, PMe<sub>2</sub>Ph, PEt<sub>2</sub>Ph, P(OMe)<sub>3</sub>, P(OEt)<sub>3</sub>, P(OEt)<sub>2</sub>Ph, PMe<sub>3</sub>, PPr<sub>3</sub><sup>i</sup>, n = 1-2, generally 20-30%; also for L = PPh<sub>3</sub>, P(OMe)<sub>3</sub>, P(OEt)<sub>3</sub>, n = 3, low yield] [24]. The monosubstituted complexes can exist as a mixture of C<sub>1</sub> and C<sub>s</sub> isomers (10a and b) as shown by the IR and NMR spectra, although the PPh<sub>3</sub> and PPr<sub>3</sub><sup>i</sup> derivatives exist only as the C<sub>s</sub> isomers. The proportions of each can be correlated with ligand basicity and size; bulky ligands limit substitution to the C<sub>s</sub> isomer, regardless of basicity, however. With smaller ligands, the C<sub>1</sub> isomer proportion increases with basicity. The X-ray structure of the PMe<sub>2</sub>Ph complex is that of the C<sub>s</sub> isomer, and shows little change over that of the parent hydrido-carbonyl. The disubstituted complexes have structure (11), in which the two ligands occupy the sites which give rise to the C<sub>s</sub> and C<sub>1</sub> isomers of the monosubstituted complexes.

Irradiation of  $\text{H}_2\text{FeRu}_3(\text{CO})_{13}$  or  $\text{H}_2\text{FeOs}_3(\text{CO})_{13}$  in isooctane in the presence of  $\text{PPh}_3$  gives clean substitution of up to two CO groups in moderately efficient reactions [21]. However, the quantum yield is markedly reduced in the presence of CO, suggesting that the latter competes with  $\text{PPh}_3$  for a photogenerated intermediate. Under CO (1 atm), cluster fragmentation of the monosubstituted derivative occurs:

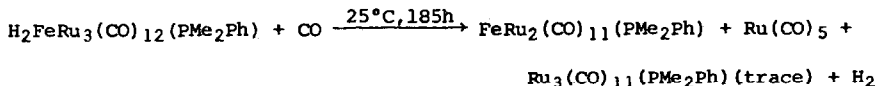

The  $\text{PPh}_3$  derivative (which exists only as the  $C_S$  isomer) gives  $\text{Fe}(\text{CO})_5$  and  $\text{Ru}_3(\text{CO})_{11}(\text{PPh}_3)$ , although with CO under pressure (200 psi),  $\text{FeRu}_2(\text{CO})_{11}(\text{PPh}_3)$  was the major trinuclear product [22]. The reasons for the two isomers giving different breakdown products are not clear at present.

The substituted complexes are fluxional, and  $^1\text{H}$ ,  $^{13}\text{C}$  and  $^{31}\text{P}$  NMR spectroscopy show that the processes are basically the same as those found with the parent hydrido-carbonyls. The phosphorus-donor ligands undergo a rapid site exchange via the facile  $C_S \rightleftharpoons C_1$  isomerisation. However, this exchange proceeds by cluster rearrangement around the ligand, the  $\text{Ru-PR}_3$  bond remaining intact (Scheme 3) [15].

This work has enabled a description of the reactivity of  $\text{H}_2\text{FeRu}_3(\text{CO})_{13}$  to be assembled [8]. The intramolecular rearrangements have rate constants of ca  $10\text{-}50 \text{ sec}^{-1}$  at  $50^\circ\text{C}$ ; thermal CO dissociation is  $10^3\text{-}10^4$  times as slow, (rate constant  $6.96 \times 10^{-4} \text{ sec}^{-1}$  at  $50^\circ\text{C}$ ). The slowest reaction is that of fragmentation with CO, an associative process which is concerted with cleavage of a metal-metal bond.

SCHEME 3 Isomerisation of  $\text{H}_2\text{FeRu}_3(\text{CO})_{12}(\text{PMe}_2\text{Ph})$

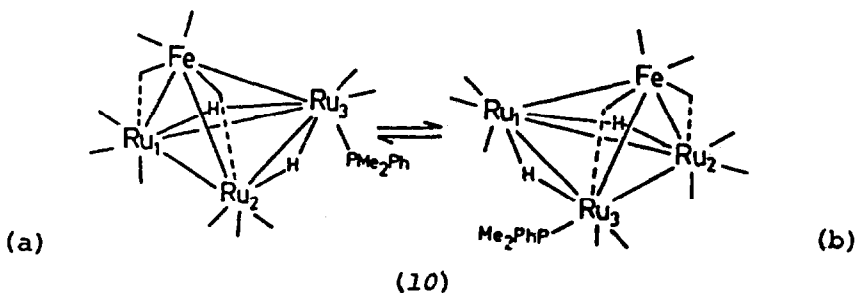

An 80% yield of  $[\text{ppn}][\text{FeRu}_3(\text{CO})_{12}(\text{NO})]$  (12) was obtained from  $[\text{ppn}][\text{Fe}(\text{CO})_3(\text{NO})]$  and  $\text{Ru}_3(\text{CO})_{12}$ ; protonation ( $\text{CF}_3\text{CO}_2\text{H}$  in  $\text{CH}_2\text{Cl}_2$ ) affords the nitrido cluster  $\text{HFeRu}_3(\mu_4\text{-N})(\text{CO})_{12}$  (13) in 75% yield by loss of oxygen as  $\text{CO}_2$  [26].

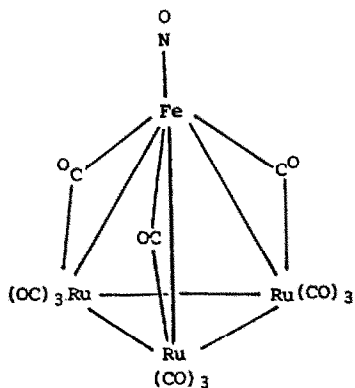

(12)

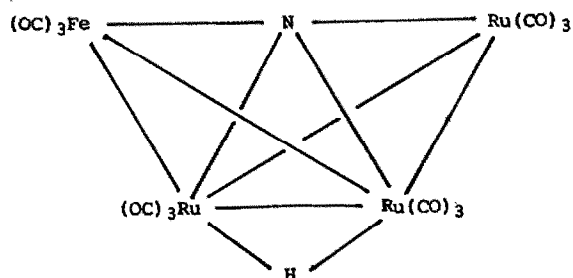

(13)

Addition of a variety of metal carbonyl species to  $\text{H}_2\text{Os}_3(\text{CO})_{10}$  occurs readily as a result of both Lewis-acid and Lewis-base nature of this cluster. These properties have been exploited in the syntheses of several mixed-metal derivatives [27]; some have been made by different routes, by addition of appropriate Lewis-base and Lewis-acid reagents:

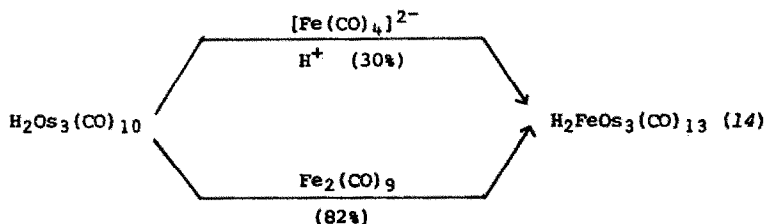

The upper reaction also gives a low yield of the pentanuclear cluster  $\text{H}_2\text{Fe}_2\text{Os}_3(\text{CO})_{16}$ .

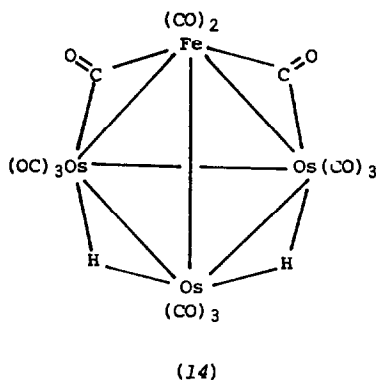
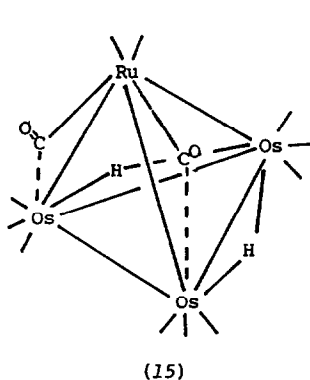

Photolysis of metal carbonyls affords unsaturated intermediates which can add to reactive substrates such as  $\text{H}_2\text{Os}_3(\text{CO})_{10}$ . Thus,  $\text{H}_2\text{FeOs}_3(\text{CO})_{13}$  is formed in >90% isolated yield by irradiating mixtures of  $\text{Fe}(\text{CO})_5$  and  $\text{H}_2\text{Os}_3(\text{CO})_{10}$ , and  $\text{H}_2\text{RuOs}_3(\text{CO})_{13}$  (15) was obtained in 23% yield by photolysis of a mixture of  $\text{Ru}_3(\text{CO})_{12}$  and  $\text{H}_2\text{Os}_3(\text{CO})_{10}$  [28]. However, similar treatment of mixture of  $\text{H}_2\text{Os}_3(\text{CO})_{10}$  or  $\text{Os}_3(\text{CO})_{12}$  with several vanadium and Group VI metal carbonyl complexes failed to give the corresponding  $\text{MOs}_3$  clusters.

**Fe, Ru, Os-Co** The variable temperature  $^{17}\text{O}$  NMR spectra of  $\text{HFeCo}_3(\text{CO})_{12}$  have been reported [27]. In contrast with the  $^{13}\text{C}$  NMR spectrum (which showed only two signals in the ratio 1/2 at  $-89^\circ$ ), the  $^{17}\text{O}$  NMR spectrum at  $-11^\circ$  confirmed the  $\text{C}_{3v}$  symmetry assumed for the parent compound on the basis of X-ray studies of substituted derivatives [29]. Above this temperature, the following fluxional processes were observed: (i) the in-plane or merry-go-round exchange of CO ligands in the basal atoms; (ii) exchange of in-plane with the remaining CO ligands on Co; (iii) total CO scrambling, at  $107^\circ\text{C}$ .

The electronic absorption spectra of  $\text{HFeCo}_3(\text{CO})_{12}$  and  $\text{HFeCo}_3(\text{CO})_{10}(\text{PPh}_3)_2$  contain broad maxima at 528 and 592 nm, respectively, with shoulders at 380 and between 280-324 nm. Photolysis of these complexes is complex and the reactions are inefficient. Irradiation of the former at 350 nm affords  $\text{Co}_4(\text{CO})_{12}$  over several days, while under CO, a slow quantitative formation of  $\text{Co}_2(\text{CO})_8$  is observed [30]. Cluster fragmentation also occurs with the

tertiary phosphine-substituted complex, to give  $\text{Co}_2(\text{CO})_6(\text{PPh}_3)_2$  as the major product. In neither case were any iron-containing products identified.

The synthesis of  $\text{HFeCo}_3(\text{CO})_9(\text{PMe}_2\text{Ph})_3$  (16) in low yield from  $\text{FeCl}_3$  and  $\text{Na}[\text{Co}(\text{CO})_4]$ , followed by addition of the tertiary phosphine, has been described, together with its X-ray structure [31]. The three  $\text{PMe}_2\text{Ph}$  ligands are disposed two to two Co atoms, and the third to Fe; three  $\mu\text{-CO}$  ligands bridge the Co-Co vectors. Coordination of suitably designed ligands, such as  $\text{HC}(\text{PPh}_2)_3$ , also occurs on an  $\text{FeCo}_2$  face of  $\text{HFeCo}_3(\text{CO})_{12}$  [32].

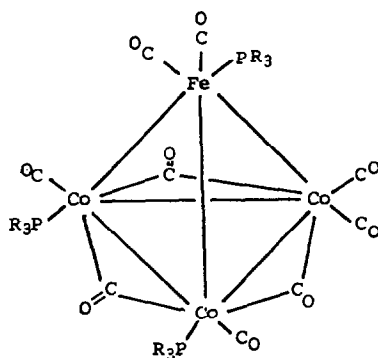

(16)

The methanol homologation reaction is catalysed by salts of  $[\text{FeCo}_3(\text{CO})_{12}]^-$  promoted by iodomethane, although the cluster is not preserved during the reaction. A detailed study of the effects of temperature, pressure and concentration was reported; the nature of the cation does not affect the conversion significantly [33]. The primary product is  $\text{MeCHO}$  (and its dimethyl acetal), accompanied by some  $\text{MeCO}_2\text{Me}$ ; under more vigorous conditions, the main product is  $\text{EtOH}$ . High conversions were obtained with the following conditions:

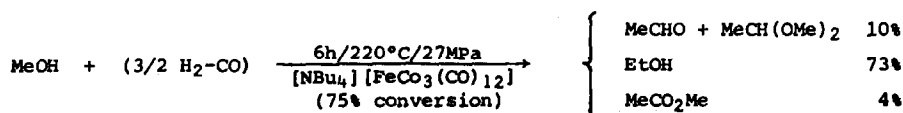

With  $\text{HFeCo}_3(\text{CO})_{12}$  as catalyst under the same conditions, only 16% conversion to a mixture of  $\text{MeCHO}$  (43%) and  $\text{EtOH}$  (47%) was achieved.

Treatment of  $\text{cis-W(N}_2)_2(\text{PMe}_2\text{Ph)}_4$  with  $\text{HFeCo}_3(\text{CO})_{12}$  in MeOH (20°C/20h) followed by addition of 40% aqueous KOH, affords  $\text{NH}_3$  and  $\text{N}_2\text{H}_4$  in best yields of 0.32 mol  $\text{NH}_3$ /W atom and 0.05 mol  $\text{N}_2\text{H}_4$ /W atom [34]. Black crystals of  $[\text{W(OR)(NNH}_2)(\text{dppe})_2][\text{FeCo}_3(\text{CO})_{12}]$  (R = Me, Et, Pr) were obtained from the reactions of  $\text{W(N}_2)_2(\text{dppe})$  with  $\text{HFeCo}_3(\text{CO})_{12}$  in the appropriate alcohols, and similar complexes are presumably intermediates in the reduction [35].

The new heterometal cluster carbonyls  $\text{RuCo}_2(\text{CO})_{11}$  (17) and  $\text{Ru}_2\text{Co}_2(\text{CO})_{13}$  (18) have been reported [36]; black (17) is formed from  $[\text{RuCl}_2(\text{CO})_3]_2$  and  $\text{K[Co(CO)}_4\text{]}$  in 76% yield, and is analogous to the osmium analogue described earlier [37]. In solution, (17) disproportionates to (18), also black, and  $\text{Co}_4(\text{CO})_{12}$ .

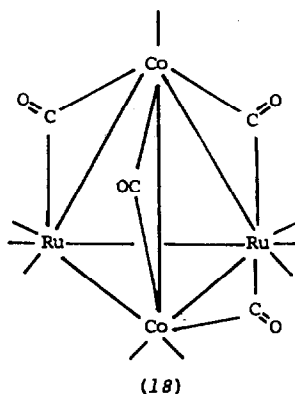
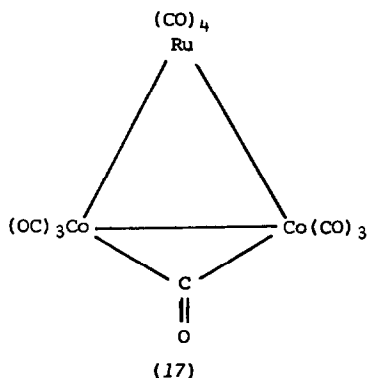

Addition of  $[\text{Co(CO)}_4]^-$  to several cluster carbonyls containing metals from the Fe-Ru-Os triad is a route to tetranuclear mixed-metal clusters containing cobalt [38]. Thus, the ppn salts of the anions  $[\text{Fe}_3\text{Co(CO)}_{13}]^-$ ,  $[\text{Fe}_2\text{RuCo(CO)}_{13}]^-$ ,  $[\text{FeRu}_2\text{Co(CO)}_{13}]^-$  and  $[\text{Ru}_3\text{Co(CO)}_{13}]^-$  were prepared from  $[\text{ppn}][\text{Co(CO)}_4]$  and the corresponding  $\text{M}_3(\text{CO})_{12}$ . Alternatively, reactions with  $\text{K[Co(CO)}_4\text{]}$ , followed by protonation, afforded  $\text{HRu}_3\text{Co(CO)}_{13}$ ,  $\text{HRu}_2\text{OsCo(CO)}_{13}$  and  $\text{HRuOs}_2\text{Co(CO)}_{13}$ , the latter two being obtained from the mixture of carbonyls obtained by heating together  $\text{Ru}_3(\text{CO})_{12}$  and  $\text{Os}_3(\text{CO})_{12}$ . Only a small amount of  $\text{HOS}_3\text{Co(CO)}_{13}$  (identified by mass spectrometry) was obtained in this way, neither were the analogous  $\text{Fe}_3\text{Co}$ ,  $\text{Fe}_2\text{RuCo}$  and  $\text{FeRu}_2\text{Co}$  hydrides formed on protonation of the respective anions. Initial attack of the  $[\text{Co(CO)}_4]^-$  is



probably on a carbonyl carbon, with concomitant M-Co bond formation and elimination of CO. Formation of the *closo* cluster then follows successive M-Co bond formation with loss of CO. The  $\text{Ru}_3\text{Co}$  anion (19) has three CO ligands bridging the three Co-Ru vectors, in a staggered arrangement to give a chiral cluster; both enantiomers are present in the crystal. The  $\text{HRu}_{3-n}\text{Os}_n\text{Co}$  ( $n = 0-3$ ) clusters probably have the hydride ligand triply-bridging the  $\text{Ru}_{3-n}\text{Os}_n$  face, which is capped on the other side by Co.

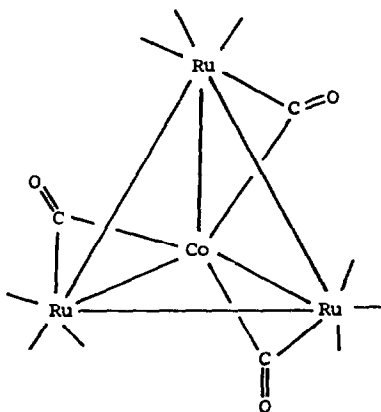

(19)

The anion (19) is also formed directly in 68% yield from the reaction of excess of  $\text{Na}[\text{Co}(\text{CO})_4]$  with hydrated  $\text{RuCl}_3$ ;  $[\text{NET}_4]^+$  and  $\text{Cs}^+$  salts were obtained by metathetical reactions [39]. These salts were also active catalysts for methanol homologation, giving  $\text{Me}_2\text{O}$  and  $\text{EtOH}$  (15-20% each) as major products with ca 40-45% conversion. In comparison,  $[\text{NET}_4][\text{Ru}_3\text{Co}(\text{CO})_{13}]$  gave 27%  $\text{Me}_2\text{O}$  and 9%  $\text{EtOH}$ , and  $\text{RhCo}_3(\text{CO})_{12}$  afforded  $\text{MeCHO} + \text{MeCH}(\text{OMe})_2$  (33%),  $\text{MeCO}_2\text{Me}$  (8.5%), and  $\text{Me}_2\text{O}$  (16%), with 52% conversion.

The synthesis of mixed-metal complexes containing osmium often fails when the syntheses of analogous iron and ruthenium complexes is successful. One cause of this may be the strength of the Os-CO bond. Dissociation of CO is assisted by photoexcitation, and Geoffroy and coworkers have shown that photolysis of a mixture of  $[\text{Co}(\text{CO})_4]^-$  and  $\text{Os}_3(\text{CO})_{12}$  provides a route to  $[\text{CoOs}_3(\text{CO})_{13}]^-$ , which could be isolated in 33% yield as the  $\text{ppn}$  salt [28].

The reaction between  $\text{HRu}_3\text{Co}(\text{CO})_{13}$  and  $\text{H}_2$  affords  $\text{H}_3\text{Ru}_3\text{Co}(\text{CO})_{12}$  (75%), which exists as two isomers, one of which has been characterised by an X-ray study as having  $C_{3v}$  symmetry (20a) [40]. IR and NMR studies suggest the second isomer has  $C_1$  symmetry (20b). These two isomers are analogous to the  $C_{3v}$  and  $C_2$  isomers of  $[\text{H}_3\text{Ru}_4(\text{CO})_{12}]^-$ . Interconversion of the isomers occurs in solution by a route which also results in exchange of all hydrogen atoms.

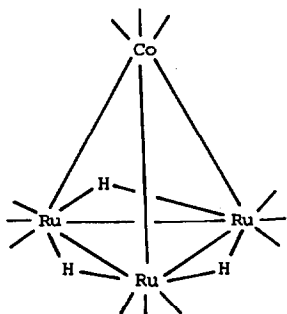

(20a)

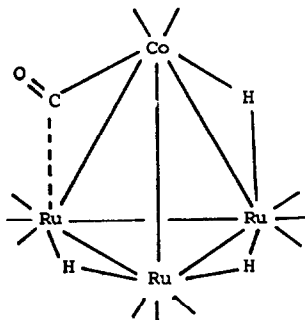

(20b)

In contrast with the  $\text{Os}_3\text{Co}$  analogue, (20) is indefinitely stable. As found with the tetranuclear clusters of the iron triad,  $\text{HRu}_3\text{Co}(\text{CO})_{13}$  and  $[\text{Ru}_3\text{Co}(\text{CO})_{13}]^-$  fragment in CO under mild conditions:

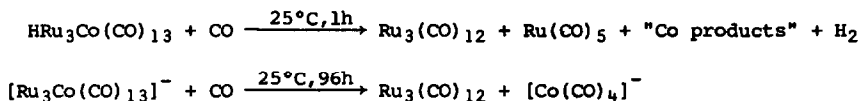

It is reported that the complex  $\text{H}_2\text{Ru}_2\text{Co}_2(\text{CO})_{12}$  was also formed (non-reproducibly) in the first reaction [22].

**Ru-Ir** Reductive carbonylation of mixtures of  $\text{RuCl}_3 \cdot x\text{H}_2\text{O}$  and  $\text{Ir}_4(\text{CO})_{12}$  afford the orange dianion  $[\text{RuIr}_4(\text{CO})_{15}]^{2-}$  (21), characterised by an X-ray study of the ppp salt [41]. The Ru atom caps one of the faces of the  $\text{Ir}_4$  tetrahedron, and two of the Ru-Ir vectors are bridged by CO. A second, black, complex is formed under nitrogen, which reacts with CO to give (21); this complex has not yet been characterised.

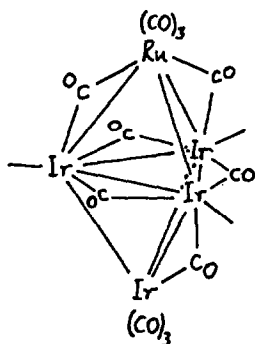

(21)

Os-Rh Black  $(\mu\text{-H})_2\text{Os}_3\text{Rh}(\text{CO})_{10}(\text{acac})$  (22) was obtained from the reaction between  $\text{H}_2\text{Os}_3(\text{CO})_{10}$  and  $\text{Rh}(\eta\text{-C}_2\text{H}_4)_2(\text{acac})$  [42]. The X-ray structure revealed an unusual bridging mode for the acac ligand, where one oxygen links the Os and Rh wing-tips of the  $\text{Os}_3\text{Rh}$  butterfly core. The hydrido ligands bridge Os-Os bonds as shown, and the short Os(1)-Os(2) bond suggests a degree of multiple bonding ('unsaturation') as expected for this 60e cluster. Chemically, this unsaturation is shown by the reaction between (22) and  $\text{PPh}_3$  to give unstable  $(\mu\text{-H})_2\text{Os}_3\text{Rh}(\text{acac})(\text{CO})_{10}(\text{PPh}_3)$ , probably having structure (23); in contrast, CO degrades (22) instantly to give  $\text{H}_2\text{Os}_3(\text{CO})_{11}$  and  $\text{Rh}(\text{CO})_2(\text{acac})$ .

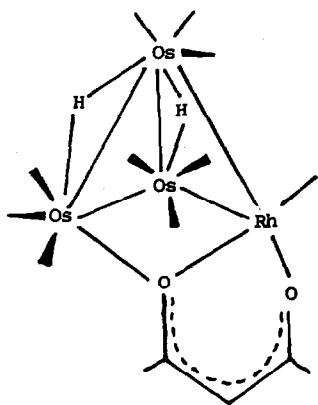

(22)

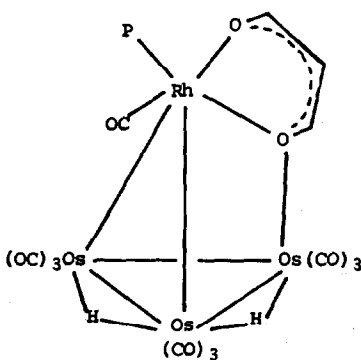

(23)

Fe-Pd,Pt Mixed Fe-Pt complexes were obtained from reactions between the anion  $[\text{HFe}_2(\text{CO})_8]^-$  and  $\text{Pt}(\eta\text{-C}_2\text{H}_4)_2(\text{PPh}_3)$ ; dark red-brown salts containing the

tetranuclear  $[(\mu\text{-H})\text{Fe}_2\text{Pt}_2(\text{CO})_8(\text{PPh}_3)_2]^-$  anion (24) were obtained [43]. The H and CO ligands undergo concomitant site exchange, a process facilitated by the presence of the negative charge. Complex (24) is isoelectronic (58e) with  $\text{Co}_2\text{Pt}_2(\text{CO})_8(\text{PPh}_3)_2$  (38, see below), and the ligand arrangements around the  $\text{M}_2\text{Pt}_2$  (M = Fe or Co) cores are similar. There are differences in detail, and the  $\text{Co}_2\text{Pt}_2$  cluster has been described as a butterfly. The Pt-Pt separations are 2.966(1) Å (Fe) and 2.987(4) (Co). The single hydride ligand in (24) was not located in the X-ray study, but geometric considerations suggest that it bridges the Fe(1)-Pt(1) vector; potential energy minima calculations reveal a second low-energy terminal site on Pt(1) trans to the Pt(1)-Pt(2) bond. Protonation of the anion (24) gives dark-red  $(\mu\text{-H})_2\text{Fe}_2\text{Pt}_2(\text{CO})_8(\text{PPh}_3)_2$  (25), which differs from (24) in having all CO ligands in terminal sites; the hydrido ligands bridge the Fe(1)-Pt(2) and Fe(2)-Pt(1) bonds. The black  $\text{Fe}_3\text{Pt}$  cluster (26) was formed from  $\text{Pt}(\eta\text{-C}_2\text{H}_4)_2(\text{PPh}_3)$  and  $[(\mu\text{-H})\text{Fe}_3(\text{CO})_{11}]^-$ ; extensive decomposition occurs in the related reaction with  $[\text{Pt}(\text{cod})(\text{C}_8\text{H}_{13})]^+$ ; but the trinuclear derivative  $\text{Fe}_2\text{Pt}(\text{CO})_8(\text{cod})$  (27) was isolated in 23% yield. This complex is related to  $\text{Fe}_2\text{Pt}(\text{CO})_9(\text{PPh}_3)$ , and the intermetallic distances are similar [44].

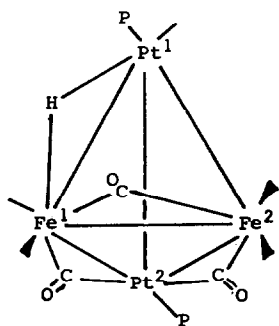

(24)

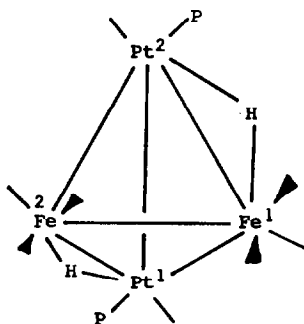

(25)

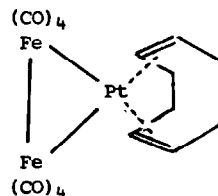

(27)

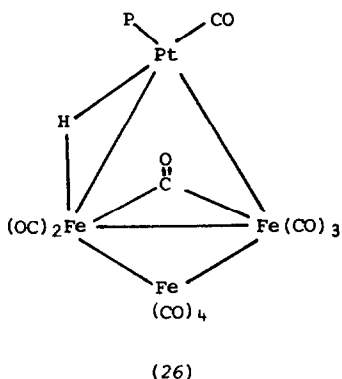

The only product obtained from reactions between  $[\text{Fe}(\text{CO})_3(\text{NO})]^-$  and  $\text{PtCl}_2(\text{PR}_3)_2$  [ $\text{R}_3 = \text{Ph}_3, \text{MePh}_2, \text{Ph}_2(\text{OMe}), \text{Ph}(\text{OMe})_2$ ] is the pentanuclear homometallic cluster  $\text{Pt}_5(\text{CO})_6(\text{PR}_3)_4$  (10-75%) [45].

Several new anionic cluster carbonyls containing iron and palladium or platinum (M) have been synthesised from  $[\text{Fe}_3(\text{CO})_{11}]^-$  and  $\text{M}^{\text{II}}$  compounds such as  $\text{MCl}_2, \text{K}_2[\text{MCl}_4], \text{MCl}_2(\text{NCPh})_2$  or  $\text{MCl}_2(\text{SET}_2)_2$ . Using a molar ratio 1/0.7, the  $[\text{Fe}_4\text{M}(\text{CO})_{16}]^{2-}$  anions are formed in 70-80% yield, and isolated as  $[\text{NMe}_3(\text{CH}_2\text{Ph})]^+$  (tmba) salts [46]. The pentanuclear anions have the "bow-tie" structure (28), in which M links two  $\text{Fe}_2(\text{CO})_8$  moieties; one CO from each iron semi bridges each M-Fe bond. The five metal atoms are almost coplanar for  $\text{M} = \text{Pd}$ , but the two  $\text{Fe}_2\text{Pt}$  triangles have a dihedral of ca  $7^\circ$ .

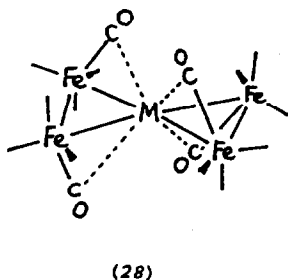

The slow reaction between equimolar amounts of  $[\text{tmba}]_2[\text{Fe}_4(\text{CO})_{13}]$  and  $\text{K}_2[\text{PdCl}_4]$  in thf gives a suspension, the solid part of which contains

SCHEME 4 Formation of Fe-Pd clusters

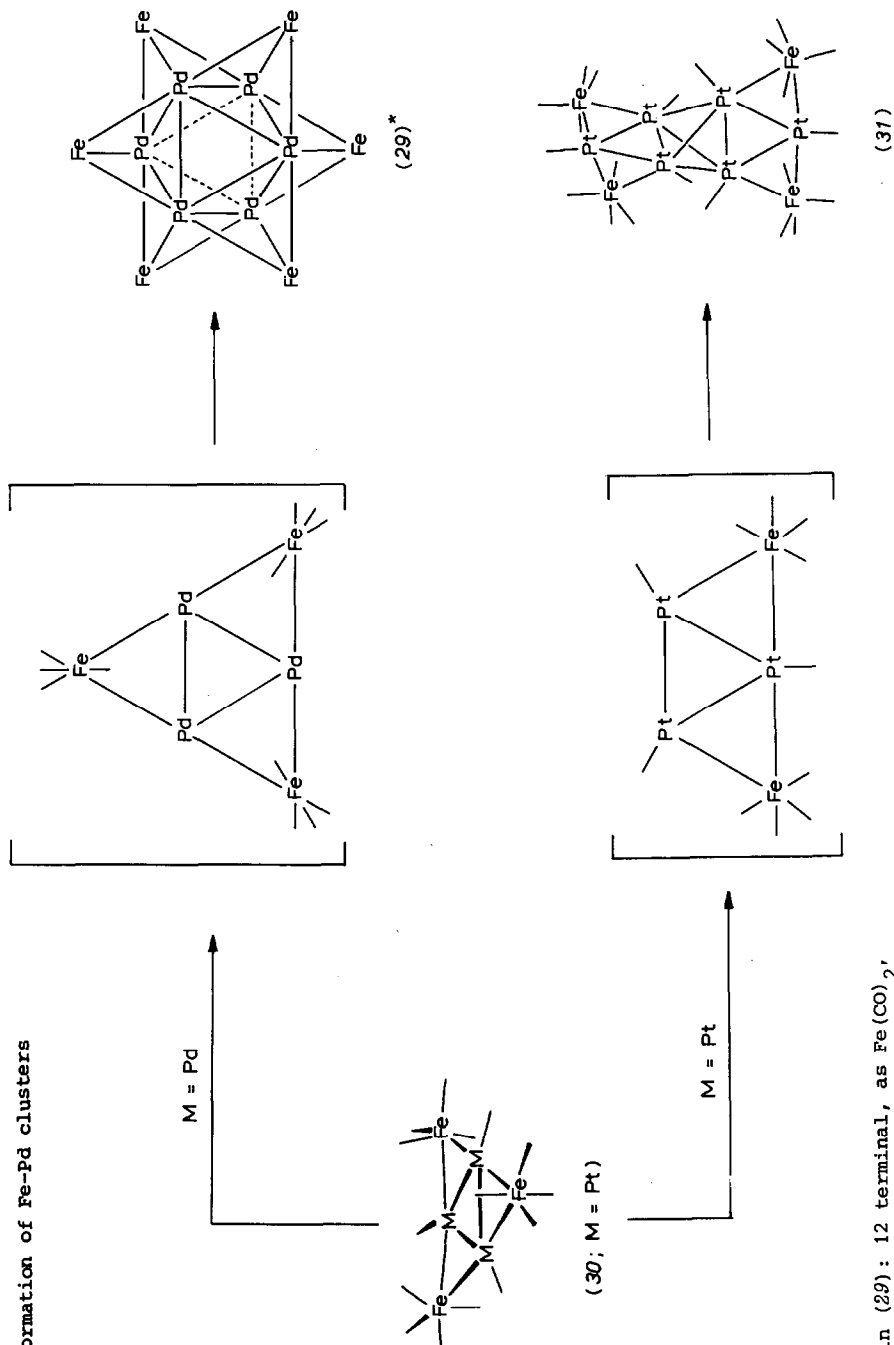

\*CO ligands in (29): 12 terminal, as  $\text{Fe}(\text{CO})_2$ ,  
 6  $\mu_2$ -CO, on Fe-Pd bonds connecting  $\text{Fe}_3\text{Pd}_3$  fragments, and  
 6  $\mu_3$ -CO, on  $\text{FePd}_2$  faces of monolayers

small amounts (5-10%) of  $[\text{tmba}]_4[\text{Fe}_6\text{Pd}_6(\text{CO})_{24}]$  and  $[\text{tmba}]_3[\text{HFe}_6\text{Pd}_6(\text{CO})_{24}]$  (29) [46]. In the latter, six lateral faces of the  $\text{Pd}_6$  octahedron are capped by iron atoms; an alternative view is an assembly of two nearly planar  $\text{Fe}_3\text{Pd}_3$  units, staggered about the  $C_3$  axis. These are fragments of two adjacent (111) layers of the f.c.c. superstructure of the  $\text{FePd}_3$  alloy. The reluctance of Pd to bond to CO is shown by the Pd atoms in (29) bonding only to bridging CO ligands; the Pd-C bonds are shorter than in (28). The location of the hydride is uncertain, but an interstitial site within the  $\text{Pd}_6$  cluster is favoured.

Green  $[\text{Fe}_3\text{Pt}_3(\text{CO})_{15}]^{2-}$  is obtained by the redox condensation of  $\text{Fe}(\text{CO})_5$  and  $[\text{Pt}_3(\text{CO})_6]^{2-}$ , as well as from  $[\text{Fe}_3(\text{CO})_{11}]^{2-}$  and  $\text{K}_2[\text{PtCl}_4]$  (mole ratio 1/1.5) [47]. If excess of  $\text{Pt}^{\text{II}}$  is present, the brown paramagnetic monoanion is formed. The two anions readily interconvert in the presence of suitable oxidising ( $\text{I}_2$  in  $\text{CH}_2\text{Cl}_2$  or  $\text{thf}$ , acids,  $\text{Cu}^+$ ,  $\text{Ag}^+$ ) or reducing (alkali hydroxide in  $\text{MeOH}$ ) agents. They are isostructural (30), and are derived from  $[\text{Pt}_3(\text{CO})_6]^{2-}$  by replacing each  $\mu\text{-CO}$  ligand with a  $\mu\text{-Fe}(\text{CO})_4$  group. The major structural difference is a shortening of the Pt-Pt bonds in the mono anion (compared with the dianion), suggesting that the HOMO involves mainly Pt AO's, and is antibonding with respect to the  $\text{Pt}_3$  moiety.

Decomposition of  $[\text{Fe}_3\text{Pt}_3(\text{CO})_{15}]^-$  occurs within a few hours at  $80\text{-}90^\circ$  to give  $[\text{Fe}_4\text{Pt}_6(\text{CO})_{22}]^{2-}$  (31). This anion is formally the result of loss of an  $\text{Fe}(\text{CO})_4$  group from the  $\text{Fe}_3\text{Pt}_3$  monoanion, followed by condensation to give a tetrahedral core. Scheme 4 represents the different condensation pathways of the  $[\text{Fe}_3\text{M}_3(\text{CO})_{15}]^-$  clusters to the  $\text{Fe}_6\text{Pd}_6$  and  $\text{Fe}_4\text{Pt}_6$  species described above. The difference is ascribed to the reluctance of Pd to bind to CO, and the condensation of two units following removal of sterically hindering groups (terminal CO from the hypothetical  $\text{Fe}_3\text{Pd}_3$  anion, or a  $\mu\text{-Fe}(\text{CO})_4$  group from the  $\text{Fe}_3\text{Pt}_3$  complex).

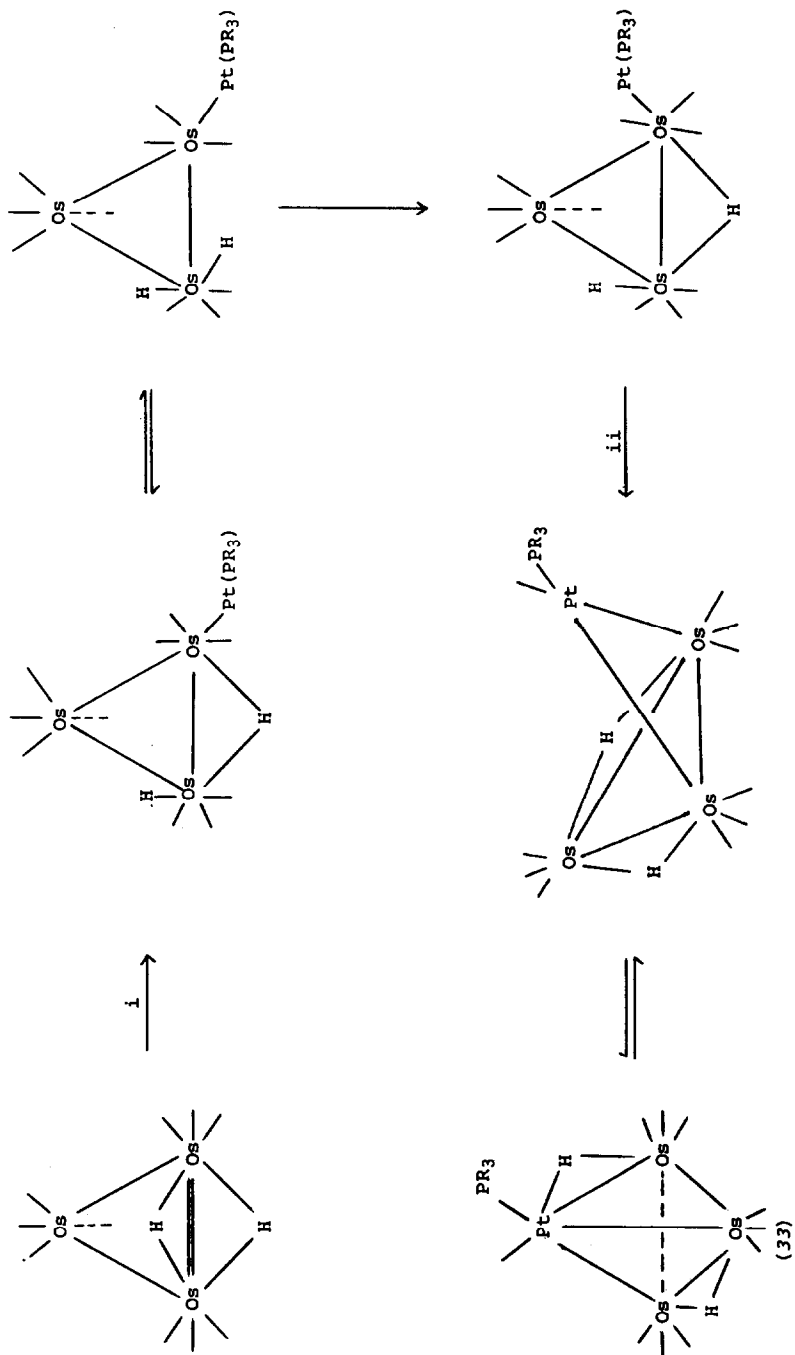
SCHEME 5 Possible mechanism for formation of an Os<sub>3</sub>Pt cluster

Reagents: i, Pt(*n*-C<sub>2</sub>H<sub>5</sub>)<sub>2</sub>(PR<sub>3</sub>)<sub>2</sub>; ii, transfer of CO to Pt

(33)



An ESR study of  $[\text{Fe}_3\text{Pt}_3(\text{CO})_{15}]^-$ , both in solution and as a solid, has been interpreted as indicating that the unpaired electron is located in the HOMO of the  $\text{Pt}_3$  system, probably the  $a_2^{1*}$  combination of the three  $d_{xy}$  orbitals [48]. The observed hyperfine splitting is caused by  $^{195}\text{Pt}$ ; there is no detectable interaction with  $^{13}\text{CO}$  in an enriched sample. The stability of this paramagnetic cluster is attributed to both the high degree of localisation of the unpaired electron, and to the steric hindrance of the bridging  $\text{Fe}(\text{CO})_4$  units.

A qualitative MO description for the clusters can be derived by formulating them as  $\{\text{Pt}_3(\text{CO})_3[\mu\text{-Fe}(\text{CO})_4]_3\}^{n-}$ , isoelectronic with  $[\text{Pt}_3(\text{CO})_3(\mu\text{-CO})_3]^{n-}$ , with the  $\mu\text{-Fe}(\text{CO})_4$  groups behaving as 2e donor ligands. The dianion is formally a 44e cluster, 18 of which can be allocated to bonding combinations of the 3 CO and 3  $\text{Fe}(\text{CO})_4$   $\sigma$  donor orbitals with the Pt 6s,  $6p_x$  and  $6p_z$  AOs. Under  $D_{3h}$  symmetry, the Pt 5d orbitals combine to give seven bonding and eight antibonding MOs; the remaining 26 electrons are accommodated in the bonding and six of the antibonding orbitals. As indicated above, this is supported by the expansion of the Pt-Pt separations on going from monoanion [2.656Å] to the dianion [2.750Å].

Os-Ni, Pt Orange  $(\mu\text{-H})_2\text{Os}_3\text{Ni}(\text{CO})_{10}(\text{PPh}_3)_2$  (32) is formed quantitatively by reaction of  $\text{H}_2\text{Os}_3(\text{CO})_{10}$  with  $\text{Ni}(\eta\text{-C}_2\text{H}_4)(\text{PPh}_3)_2$ , and contains a tetrahedral  $\text{Os}_3\text{Ni}$  core; two of the Ni-Os bonds are asymmetrically bridged by CO ligands [42]. Attempts to obtain "unsaturated" 58e clusters, e.g. by reaction of  $\text{H}_2\text{Os}_3(\text{CO})_{10}$  with  $\text{Ni}(\text{cdt})(\text{PPh}_3)$ , were unsuccessful.

The dark green tetranuclear complexes  $(\mu\text{-H})_2\text{Os}_3\text{Pt}(\text{CO})_{10}(\text{PR}_3)$  (33;  $\text{R}_3 = \text{Cy}_3, \text{Ph}_3, \text{MeBu}_2^t$ ) have been obtained from reactions between  $\text{H}_2\text{Os}_3(\text{CO})_{10}$  and  $\text{Pt}(\eta\text{-C}_2\text{H}_4)_2(\text{PR}_3)$  [49]. These complexes exhibit dynamic behaviour interpreted as a two-site exchange process involving the two  $\mu\text{-H}$  ligands, with activation energy for the  $\text{PCy}_3$  derivative of  $\Delta G^\ddagger = 58 \pm 2 \text{ kJ mol}^{-1}$ . A possible mechanism for the formation of (33) is shown in Scheme 5.

The 58e clusters (33) react with CO,  $\text{PPh}_3$  or  $\text{AsPh}_3$  to give the bright yellow 60e clusters  $(\mu\text{-H})_2\text{Os}_3\text{Pt}(\text{CO})_{10}(\text{PR}_3)(\text{L})$  ( $\text{PR}_3 = \text{PCy}_3, \text{L} = \text{CO}; \text{PR}_3 =$

$\text{PPh}_3$ ,  $\text{L} = \text{PPh}_3$  or  $\text{AsPh}_3$ ), which contain an  $\text{Os}_3\text{Pt}$  butterfly core [50]. In the  $\text{PPh}_3$  adduct (34), which is not isostructural with the  $\text{NiOs}_3$  complex (32), one  $\text{PPh}_3$  is attached to Pt and the other to Os. In solution (34) exists as two isomers, which interconvert rapidly at room temperature. Comparison of the skeletal structures of (33) and (34) shows major differences in the Pt-Os(2) bond [which is cleaved in the formation of (34)], the Os(1)-Os(2) bond [trans to  $\text{PPh}_3$  in (34)], and the Os(1)-Os(3) bond [perhaps the site of "unsaturation" in (33)].

A chemically-reversible but slow 2e reduction of (33) occurs at  $E_p = -0.9\text{v}$  vs SCE, but while Na/Hg reduction gave a dark red-purple solution, no salts of the supposed dianion  $[(\mu\text{-H})_2\text{Os}_3\text{Pt}(\text{CO})_{10}(\text{PPh}_3)]^{2-}$  were isolable.

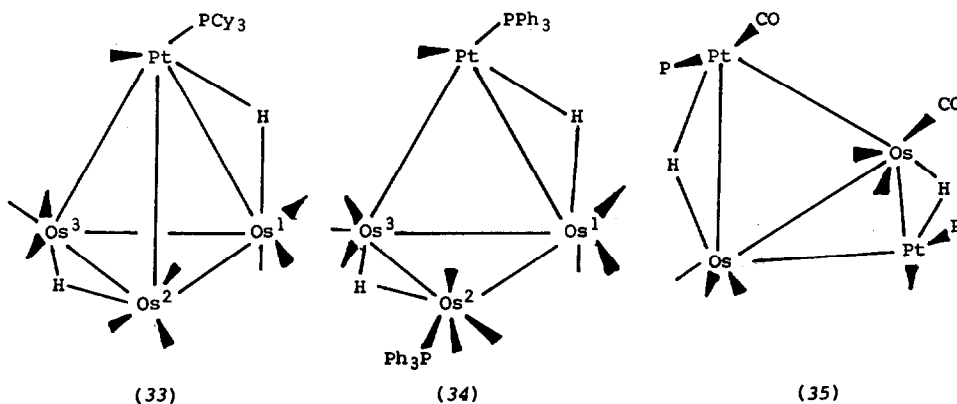

	Bond distances ( $\text{\AA}$ )	
	(33)	(34)
Pt-Os(1)	2.863(1)	2.848(1)
Pt-Os(2)	2.791(1)	3.530(1)
Pt-Os(3)	2.832(1)	2.717(1)
Os(1)-Os(2)	2.777(1)	2.914(1)
Os(1)-Os(3)	2.741(1)	2.773(1)
Os(2)-Os(3)	2.789(1)	3.043(1)

The polymer-supported cluster obtained by phosphine exchange between  $\text{H}_2\text{Os}_3\text{Pt}(\text{CO})_{10}(\text{PPh}_3)_2$  and a  $\text{PPh}_2$ -functionalised styrene-divinylbenzene copolymer is not active for ethylene hydrogenation [51].

The reaction between  $\text{H}_2\text{Os}(\text{CO})_4$  and  $\text{Pt}(\eta\text{-C}_2\text{H}_4)_2(\text{PR}_3)$  affords orange  $(\mu\text{-H})_2\text{Os}_2\text{Pt}_2(\text{CO})_8(\text{PR}_3)_2$  (35; R = Ph, Cy, Me), in which rapid site-exchange of the H ligands occurs between the two Pt atoms; the  $\text{PMe}_3$  complex was the most dynamic [52]. The molecular structure closely resembles that of the analogous  $\text{Fe}_2\text{Pt}_2$  complex (25), although in this case the  $\text{Os}_2\text{Pt}_2$  core is a butterfly, with the wing-tip Pt-Pt separation  $3.206(1)\text{\AA}$ , compared with  $2.998(2)\text{\AA}$  in (25).

Co-Rh The complexes  $\text{Co}_2\text{Rh}_2(\text{CO})_{12-n}[\text{P}(\text{OMe})_3]_n$  and  $\text{Co}_3\text{Rh}(\text{CO})_{12-n}[\text{P}(\text{OMe})_3]_n$  ( $n = 1-3$  in each case) have been prepared from the parent Co-Rh carbonyls and  $\text{P}(\text{OMe})_3$  [53]. In reactions with larger ratios of added ligand, some cluster fragmentation (to give  $\text{Co}_2(\text{CO})_6[\text{P}(\text{OMe})_3]_2$ ) and metal redistribution occurs. Interaction of  $\text{Co}_2(\text{CO})_6[\text{P}(\text{OMe})_3]_2$  and  $[\text{RhCl}(\text{CO})_2]_2$  afforded  $\text{Co}_2\text{Rh}_2(\text{CO})_{10}[\text{P}(\text{OMe})_3]_2$  as the major product. Several complexes exist in solution as a mixture of isomers (IR), and NMR studies indicated that all complexes except  $\text{Co}_3\text{Rh}(\text{CO})_{12-n}[\text{P}(\text{OMe})_3]_n$  ( $n = 2, 3$ ) are fluxional. Only the  $\text{CoRh}_2$  face of the  $\text{Co}_2\text{Rh}_2$  cluster is capped by  $\text{HC}(\text{PPh}_2)_3$  in the 1:1 complex [32].

Co-Pd, Pt Reactions between  $\text{Na}[\text{Co}(\text{CO})_4]$  and  $\text{MCl}_2(\text{dppe})$  ( $\text{M} = \text{Pd}$  or  $\text{Pt}$ ) afford the clusters  $(\text{dppe})\text{MCo}_2(\text{CO})_7$  in 89% (Pd) and 78% (Pt) yields; the latter was also obtained from  $\text{Pd}(\text{C}\equiv\text{CPh})_2(\text{dppe})$  [39]. The heterometallic complexes have been used as methanol homologation catalysts, giving 50-60% conversions to mixtures rich in  $\text{MeCHO} + \text{MeCH}(\text{OMe})_2$  and  $\text{Me}_2\text{O}$ . High yields of  $\text{Co}_2\text{Pt}(\text{CO})_8(\text{PPh}_3)$  (36), similar to the dppe complex described above, were obtained from reactions between  $\text{Co}_2(\text{CO})_8$  and  $\text{Pt}_5(\text{CO})_6(\text{PR}_3)_4$  [45].

Electrochemical reduction of the  $\text{Co}_2\text{Pt}$  clusters (36) and (37) occurs at  $E_1 = -0.75\text{V}$  [ $\text{LL}' = (\text{CO})(\text{PPh}_3)$ ] and  $-1.20\text{V}$  ( $\text{LL}' = \text{dppe}$ ), respectively [54]. The reduction is irreversible, and is followed in both cases

by a reaction which affords  $[\text{Co}(\text{CO})_4]^-$ . Exhaustive reduction of (36) affords  $\text{Co}_2\text{Pt}_2(\text{CO})_8(\text{PPh}_3)_2$  (38) (68% isolated yield), presumably by fast dimerisation of a radical intermediate:

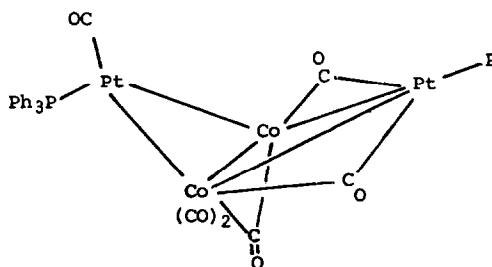
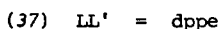
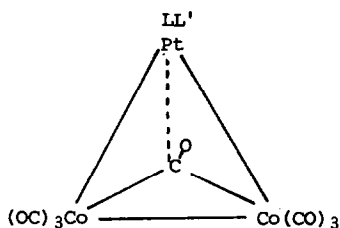
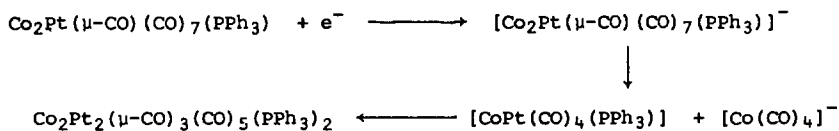

Phosphine exchange between  $\text{Co}_2\text{Pt}_2(\text{CO})_8(\text{PPh}_3)_2$  and  $\text{PPh}_2$ -functionalised poly(styrene-divinylbenzene) gives a heterometallic catalyst for ethylene hydrogenation (1 atm,  $<100^\circ\text{C}$ ) on a polymeric support [51].

**Rh-Ni** Almost quantitative formation of  $[\text{Rh}_6\text{Ni}(\text{CO})_{16}]^{2-}$  (39) occurs on mixing solutions of  $[\text{Rh}_6(\text{CO})_{15}]^{2-}$  and  $[\text{Ni}_6(\text{CO})_{12}]^{2-}$  salts; the co-product  $[\text{Rh}_7(\text{CO})_{16}]^{3-}$  precipitates out, and well-formed crystalline salts of the mixed-metal anion can be obtained in high yield:

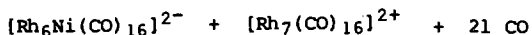
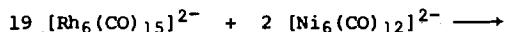

In the  $\text{NBu}_4^+$  salt, the anion contains an  $\text{Rh}_6$  octahedron (distorted towards a trigonal antiprism) capped on one face by the nickel atom [55].

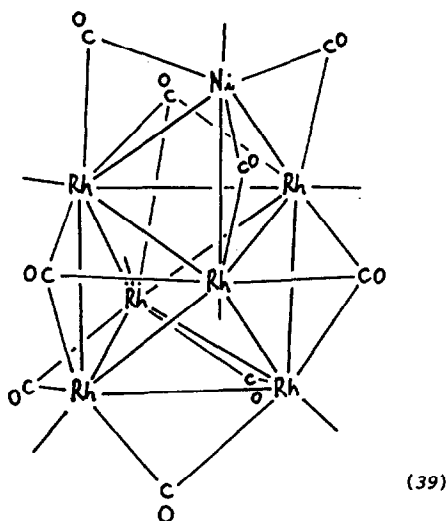

Other anionic Ni-Rh cluster carbonyls have been observed, but not fully characterised [55]. The reaction between  $\text{Rh}_4(\text{CO})_{12}$  and  $[\text{Ni}_5(\text{CO})_{12}]^{2-}$  affords brown  $[\text{Rh}_5\text{Ni}(\text{CO})_{15}]^-$ , which reacts immediately with CO to give  $[\text{Rh}_5(\text{CO})_{15}]^-$  and  $\text{Ni}(\text{CO})_4$ . Similarly,  $[\text{Rh}_4(\text{CO})_{11}]^{2-}$  reacts with excess  $\text{Ni}(\text{CO})_4$  to give yellow-orange  $[\text{Rh}_4\text{Ni}(\text{CO})_{14}]^{2-}$ , which loses CO to give red-brown  $[\text{Rh}_4\text{Ni}(\text{CO})_{12}]^{2-}$ .

## 2. HETERONUCLEAR METAL CLUSTER CARBOXYLS CONTAINING $\eta$ -CYCLOPENTADIENYL LIGANDS

**Cr, Mn, Fe-CO** One method of synthesising mixed-metal clusters is the addition of coordinatively-unsaturated species across metal-metal multiple bonds. The utility of this route has been extended by generating the unsaturated species photochemically in the presence of the multiply-bonded substrate. Thus, irradiation of mixtures of  $[\text{Co}(\mu\text{-CO})(\eta\text{-C}_5\text{Me}_5)]_2$  with  $\text{Cr}(\text{CO})_3(\eta^6\text{-C}_6\text{H}_5\text{Me})$ ,  $\text{Mn}(\text{CO})_3(\eta^5\text{-C}_5\text{H}_4\text{Me})$ , or  $\text{Fe}(\text{CO})_3(\eta\text{-C}_4\text{H}_4)$  afforded the complexes  $\text{MCo}_2(\mu_3\text{-CO})(\mu\text{-CO})_3(\eta\text{-C}_5\text{Me}_5)_2$  (40) [ $\text{M} = \text{Cr}(\eta^6\text{-C}_6\text{H}_5\text{Me})$ ,  $\text{Mn}(\eta^5\text{-C}_5\text{H}_4\text{Me})$  or  $\text{Fe}(\eta\text{-C}_4\text{H}_4)$ , respectively] in 33-45% yields; the compound  $\text{FeCo}_2(\mu_3\text{-CO})(\mu\text{-CO})_2(\text{CO})_3(\eta\text{-C}_5\text{Me}_5)_2$  (41) was obtained (27%) when  $\text{Fe}_2(\text{CO})_9$  was used as precursor [56].

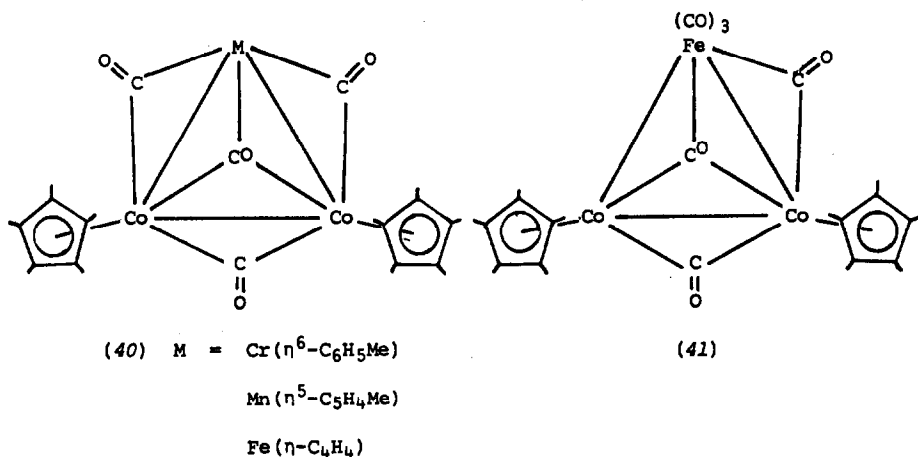

W-Ir Convenient syntheses of  $WIr_3(CO)_{11}(\eta-C_5H_5)$  (42) and  $W_2Ir_2(CO)_{10}-(\eta-C_5H_5)_2$  (43), from  $IrCl(CO)_2[NH_2(tol)]$  and  $HW(CO)_3(\eta-C_5H_5)$  [60°C, 6h, 40 psig CO; 70-80% (42)] or  $[W(CO)_3(\eta-C_5H_5)]^-$  (25°C, 2h) [85% (43)] have been reported [57]. Conversion of (43) to (42) occurs on treatment with CO (110°C, 2h, 40 psig, 53%). Although X-ray structures show the expected  $M_4$  cores based on that of  $Ir_4(CO)_{12}$ , the detailed ligand arrangements suggest that (42) is an adduct of the triply-bonded species  $(\eta-C_5H_5)(OC)_2W \equiv W(CO)_2-(\eta-C_5H_5)$  and  $(OC)_3Ir \equiv Ir(CO)_3$ , and that (43) is the formal dimer of  $(\eta-C_5H_5)(OC)_2W \equiv Ir(CO)_3$ . The  $W_2Ir_2$  complex is an analogue of a similar  $Mo_2Co_2$  intermediate proposed as the first product in reactions between  $[Mo(CO)_2-(\eta-C_5H_5)]_2$  and  $Co_2(CO)_8$ ; other related compounds include the  $WCo_2C$  cluster obtained from  $W[C(tol)](CO)_2(\eta-C_5H_5)$  and  $Co_2(CO)_8$  (see below).

These complexes have been used to prepare catalysts by adsorption onto alumina and decomposition in hydrogen. In the latter reaction, most of the coordinated CO is hydrogenated to methane; temperature profiles for evolved CO and CH<sub>4</sub> differ for (42) and (43). The decomposed materials were used as catalysts for *n*-butane hydrogenation; the  $WIr_3$ -derived catalyst showed 75% selectivity for cleavage of the central C-C bond to give 2C<sub>2</sub>H<sub>6</sub>; the  $W_2Ir_2$ -derived catalyst gave <50% ethane, evidence for a W-Ir interaction modifying the catalytic site. Particle sizes were <10Å.

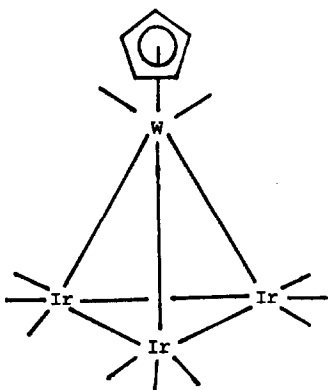

(42)

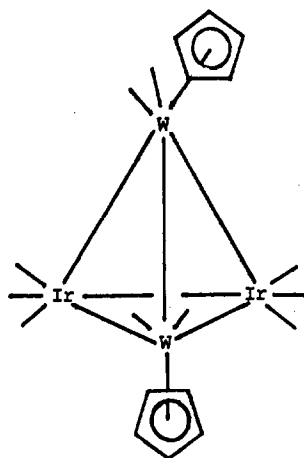

(43)

**Fe-Ir** The  $\text{Fe}_2\text{Ir}$  cluster (44) has been obtained from the reaction between  $\text{Fe}_3(\text{CO})_{12}$  and  $[\text{IrCl}_2(\eta\text{-C}_5\text{Me}_5)]_2$  or  $\text{Ir}(\text{CO})_2(\eta\text{-C}_5\text{Me}_5)$ ; the latter is an intermediate, but is also formed on heating (44) to  $80^\circ$ . The X-ray structure shows the Fe-Ir bond to be bridged by two CO groups; (44) is thus similar to the  $\text{Fe}_2\text{Co}$  analogue, but differs from the  $\text{Fe}_2\text{Rh}$  complex, in which the CO ligands bridge the Fe-Fe vector [59].

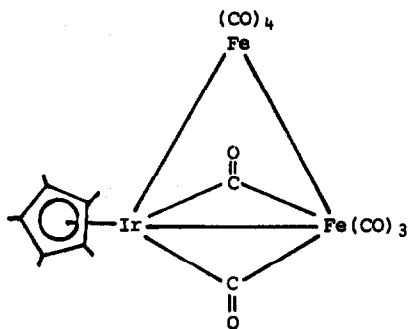

(44)

**Os-Co** The reaction between  $\text{H}_2\text{Os}_3(\text{CO})_{10}$  and  $\text{Co}(\text{CO})_2(\eta\text{-C}_5\text{H}_5)$  affords  $\text{H}_2\text{Os}_3\text{Co}(\text{CO})_{10}(\eta\text{-C}_5\text{H}_5)$  (45) [27].

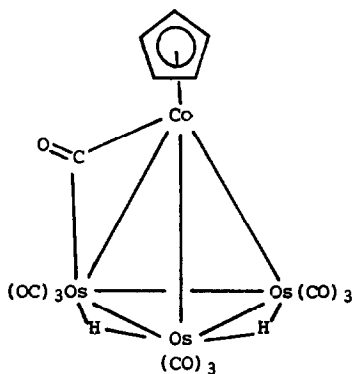

(45)

Fe, Ru, Os-Ni      The dark green Fe-Ni cluster (46) can be obtained by heating mixtures of either  $\text{Fe}(\text{CO})_5$  or  $\text{Fe}_3(\text{CO})_{12}$  with  $[\text{Ni}(\text{CO})(\eta\text{-C}_5\text{H}_5)]_2$ , or of  $\text{Fe}_3(\text{CO})_{12}$  and  $\text{Ni}(\eta\text{-C}_5\text{H}_5)_2$  in refluxing heptane [60]. The  $\text{Fe}_2\text{Ni}$  face-capping CO ligand gives rise to  $\nu(\text{CO})$  at  $1722\text{ cm}^{-1}$ .

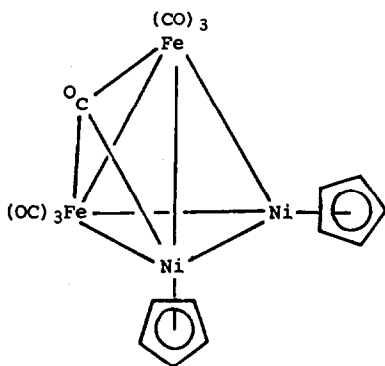

(46)

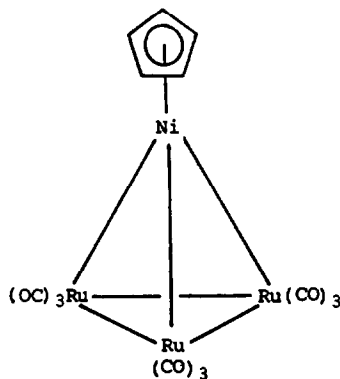

(47)

The related complex  $\text{Ru}_3\text{Ni}(\text{CO})_9(\eta\text{-C}_5\text{H}_5)$  (47) has been obtained from several reactions between ruthenium carbonyls and  $\text{Ni}(\eta\text{-C}_5\text{H}_5)$  compounds; however, as proposed, the structure is three electrons-deficient [61].

The reaction between  $\text{Os}_3(\text{CO})_{12}$  and an excess of  $[\text{Ni}(\text{CO})(\eta\text{-C}_5\text{H}_5)]_2$  (refluxing octane, 40 min) affords dark-brown  $\text{Os}_3\text{Ni}_3(\text{CO})_9(\eta\text{-C}_5\text{H}_5)_3$  (48) in 40% yield. The metal core is a face-capped trigonal bipyramid; in solution,



only one  $C_5H_5$  resonance is observed, suggesting that the cluster is fluxional in solution [62].

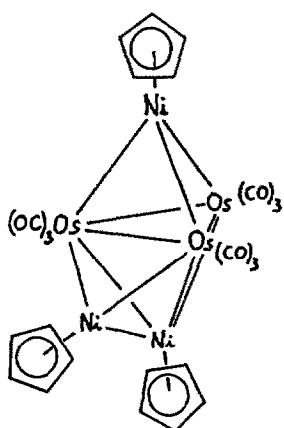

(48)

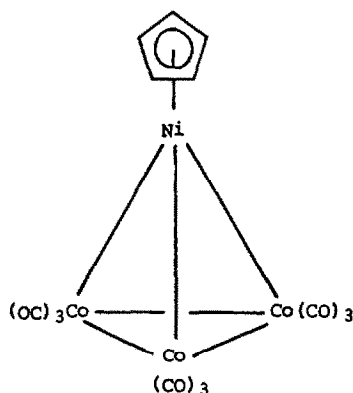

(49)

Co-Ni Direct exchange between  $Co_4(CO)_{12}$  and  $[Ni(CO)(\eta-C_5H_5)]_2$  afforded the  $NiCo_3$  cluster (49) in up to 90% yield [63].

Reactions between equimolar amounts of  $[Ni(CO)(\eta-C_5H_5)]_2$  and  $Co(CO)_2(\eta-C_5H_5-nMe_n)$  ( $n = 0, 1$  and  $5$ ) afforded the mixed metal clusters  $CoNi_2(CO)_2(\eta-C_5H_5)_2(\eta-C_5H_5-nMe_n)$  (50) [64]. Structural studies of these complexes [which are considered to be directly related to the monocation of  $Ni_3(CO)_2(\eta-C_5H_5)_3$ ] were expected to resolve the problem of the location of the unpaired electron in the paramagnetic neutral  $Ni_3$  cluster, i.e. between the Longuet-Higgins-Stone and the Strouse-Dahl models. The parent  $CoNi_2$  cluster and the  $C_5H_4Me$  analogue have a three-fold disorder; the  $C_5Me_5$  complex has an Ni-Ni bond [ $2.326(2)\text{\AA}$ ] shorter than the Co-Ni distances (av.  $2.371\text{\AA}$ ), although the mean M-M bond length ( $2.356\text{\AA}$ ) is almost identical with that found for  $CoNi_2(CO)_2(\eta-C_5H_5)_3$  [ $2.358(2)\text{\AA}$ ]. This is taken to support the Strouse-Dahl model, in which the unpaired electron is placed in an MO ( $a_2$ ) which is strongly antibonding with respect to the  $Ni_3$  system. Spectral and electrochemical studies quantified the increasing electron release from the  $C_5R_5$  groups on substitution of Me for H; cyclic voltammetry gave  $E_1$  values for the three complexes ( $n = 0, 1, 5$ ) of  $-1.525$ ,  $-1.558$  and  $-1.693V$  (vs

Ag/Ag<sup>+</sup> reference electrode), respectively, consistent with the C<sub>5</sub>Me<sub>5</sub> derivative being hardest to reduce.

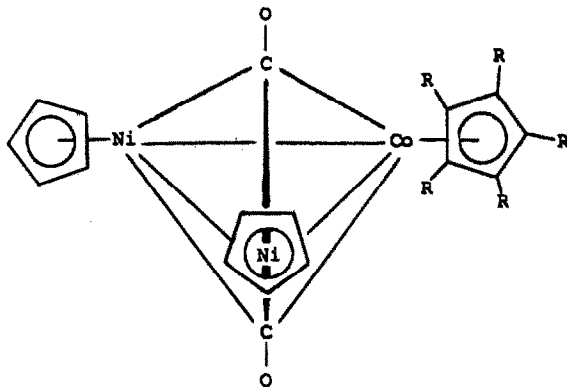

(50)

Rh-Pt The complex Rh<sub>2</sub>(μ-CO)<sub>2</sub>(η-C<sub>5</sub>Me<sub>5</sub>)<sub>2</sub> reacts rapidly with Pt(cod)<sub>2</sub>, Pt(η-C<sub>2</sub>H<sub>4</sub>)(PPh<sub>3</sub>)<sub>2</sub> or [Pt(CO)(η-C<sub>5</sub>H<sub>5</sub>)]<sub>2</sub> to give the trinuclear Rh<sub>2</sub>Pt clusters (51), (52) and (53), respectively [65]. In these reactions, 14e fragments [Pt(cod), Pt(CO)(PPh<sub>3</sub>) or Pt(CO)<sub>2</sub>] are captured by the unsaturated Rh<sub>2</sub> precursor, which is isolobal with ethylene. The three heteronuclear clusters contain semi-triply-bridging CO ligands [ν(CO) 1708, 1711, and 1724 and 1730 cm<sup>-1</sup>, respectively].

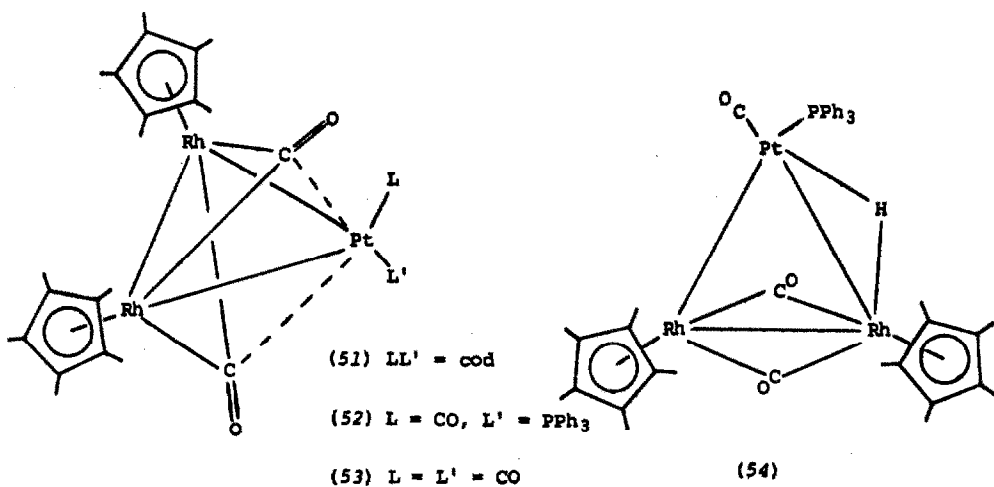

Protonation of (52) affords the fluxional cation  $[(\mu\text{-H})\text{Rh}_2\text{Pt}(\mu\text{-CO})_2\text{-}(\text{PPh}_3)(\eta\text{-C}_5\text{Me}_5)_2]^+$  (54), in which the  $\mu\text{-H}$  ligand bridges the Rh-Pt vector [66]. The dynamic process involves rotation of the  $\text{Rh}_2$  moiety about an axis through Pt and the midpoint of the Rh-Rh bond; this is consistent with averaging of the  $J(\text{HRh})$  and  $J(\text{PRh})$  couplings, but the constancy of the  $J(\text{HPT})$  and  $J(\text{HP})$  couplings implies that the  $\text{HPT}(\text{CO})(\text{PPh}_3)$  unit retains its integrity during this process:

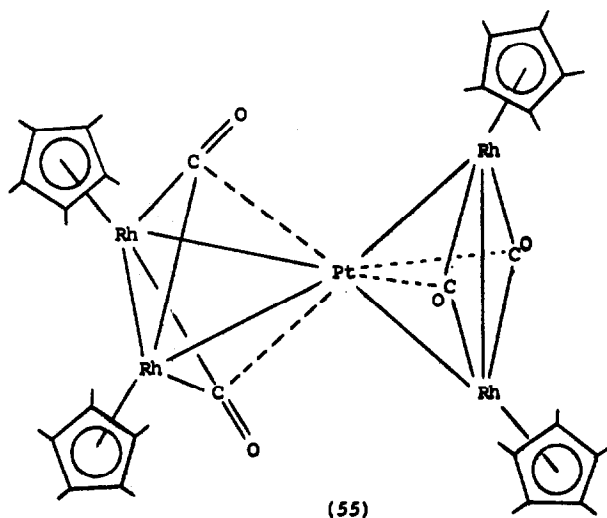

Following the isolobal analogy, the  $\text{Rh}_2$  complex was also reacted with  $\text{Pt}(\eta\text{-C}_2\text{H}_4)_3$  to give the red-black pentanuclear  $\text{Rh}_4\text{Pt}$  cluster  $\text{Rh}_4\text{Pt}(\mu\text{-CO})_4(\eta\text{-C}_5\text{Me}_5)_4$  (55). Two crystalline modifications of this complex differ in the angles between the two  $\text{PtRh}_2$  planes, which are  $90^\circ$  (the molecule also has a mirror plane) and  $100^\circ$  (where the Pt atom lies in a crystallographic two-fold axis) [66].

## 3. HETERONUCLEAR METAL CARBIDE CLUSTERS

The syntheses of several mixed metal carbide clusters have been described [67,68]. The reactions are based on polyhedral expansion and contraction reactions. The former utilise the anionic iron carbide clusters  $[\text{Fe}_4(\mu_4\text{-C})(\text{CO})_{12}]^{2-}$  and  $[\text{Fe}_5(\mu_5\text{-C})(\text{CO})_{14}]^{2-}$ , in both of which the carbide atom is exposed. Syntheses involving polyhedral contraction were based on the heteronuclear  $[\text{Fe}_5\text{M}(\mu_6\text{-C})(\text{CO})_X]^{Y-}$  clusters.

The iron carbide clusters are open polyhedra (butterfly or square pyramidal metal cores) with relatively high electron density. The wide range of heteronuclear products obtained is summarised in Schemes 6 and 7, and the paper describes several limitations, e.g. non-reactivity of several monoanionic clusters, and reduction if the charge relationships were reversed. Cluster degradation by oxidation (usually  $\text{Fe}^{3+}$ ) leads to polyhedral contraction, specifically of  $\text{Fe}_5\text{MC}$  clusters to square pyramidal  $\text{Fe}_4\text{MC}$  clusters by removal of one iron atom:

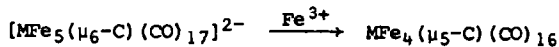

M = Cr, Mo, W

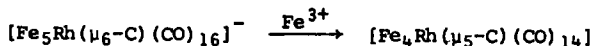

An exception is the  $[\text{Fe}_5\text{Ni}(\mu_6\text{-C})(\text{CO})_{15}]^{2-}$  ion, which is oxidised to the neutral  $\text{Fe}_5\text{Ni}(\mu_6\text{-C})(\text{CO})_{16}$  cluster. The  $\text{MoFe}_4\text{C}$  complex was also prepared by oxidation of  $[\text{HMoFe}_5(\mu_6\text{-C})(\text{CO})_{16}]^{3-}$ , itself prepared from  $\text{Mo}_2(\text{OAc})_4$  and  $[\text{Fe}(\text{CO})_4]^{2-}$ .

The structures of the anions in  $[\text{NET}_4]_2[\text{MoFe}_5(\mu_6\text{-C})(\text{CO})_{17}]$  (56) and  $[\text{NET}_4][\text{Fe}_4\text{Rh}(\mu_5\text{-C})(\text{CO})_{14}]$  (57) show the carbide atom enclosed within the  $\text{M}_6$  octahedron in the former, but exposed and projecting from an  $\text{M}_4$  square face in the latter [67].

The heteronuclear clusters all exhibit facile CO exchange, although activation energies for this process were higher for square pyramidal

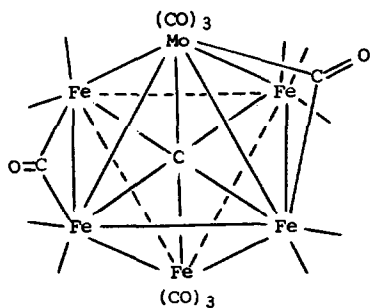

(56)

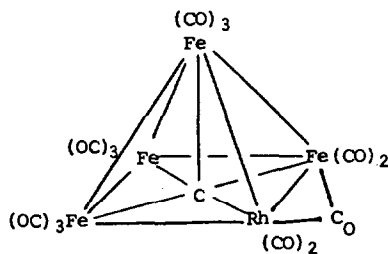

(57)

clusters than for the octahedral systems. In the former, CO site exchange between apical and basal metal atoms was slow; ligands such as cod resulted in higher activation energies for basal intermetal CO site exchange.

Addition of  $[\text{Cu}(\text{NCMe})_4]^+$  to the trigonal prismatic ion  $[\text{Rh}_6(\mu_6\text{-C})(\text{CO})_{15}]^{2-}$  affords  $\text{Rh}_6\text{Cu}_2(\mu_6\text{-C})(\text{CO})_{15}(\text{NCMe})_2$  (58), in which the additional copper ions have capped the triangular faces of the prism [69].

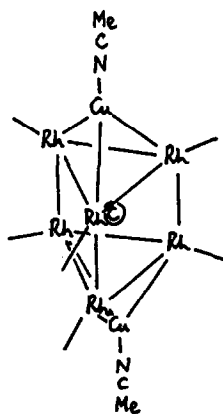

(58)

All Rh-Rh edges  
bridged by  $\mu$ -CO  
ligands

#### 4. HETERONUCLEAR METAL CLUSTERS CONTAINING GROUP IB METALS

Although mixed-metal clusters containing gold atoms had been reported previously, attention was drawn to these species by a communication from Lauher and Wald [70], who pointed out that the  $\text{Au}(\text{PR}_3)$  group is isolobal

with the H atom. While the gold atoms are large, the bonds to other metal atoms are longer, and hence there is no steric hindrance expected; electronically, the similarity has between H 1s orbital and the Au 6s orbital, although others prefer the bond to involve the corresponding *sp*

SCHEME 6 Syntheses of heteronuclear metal carbide clusters from  $[\text{Fe}_4(\mu_4\text{-C})(\text{CO})_{12}]^{2-}$

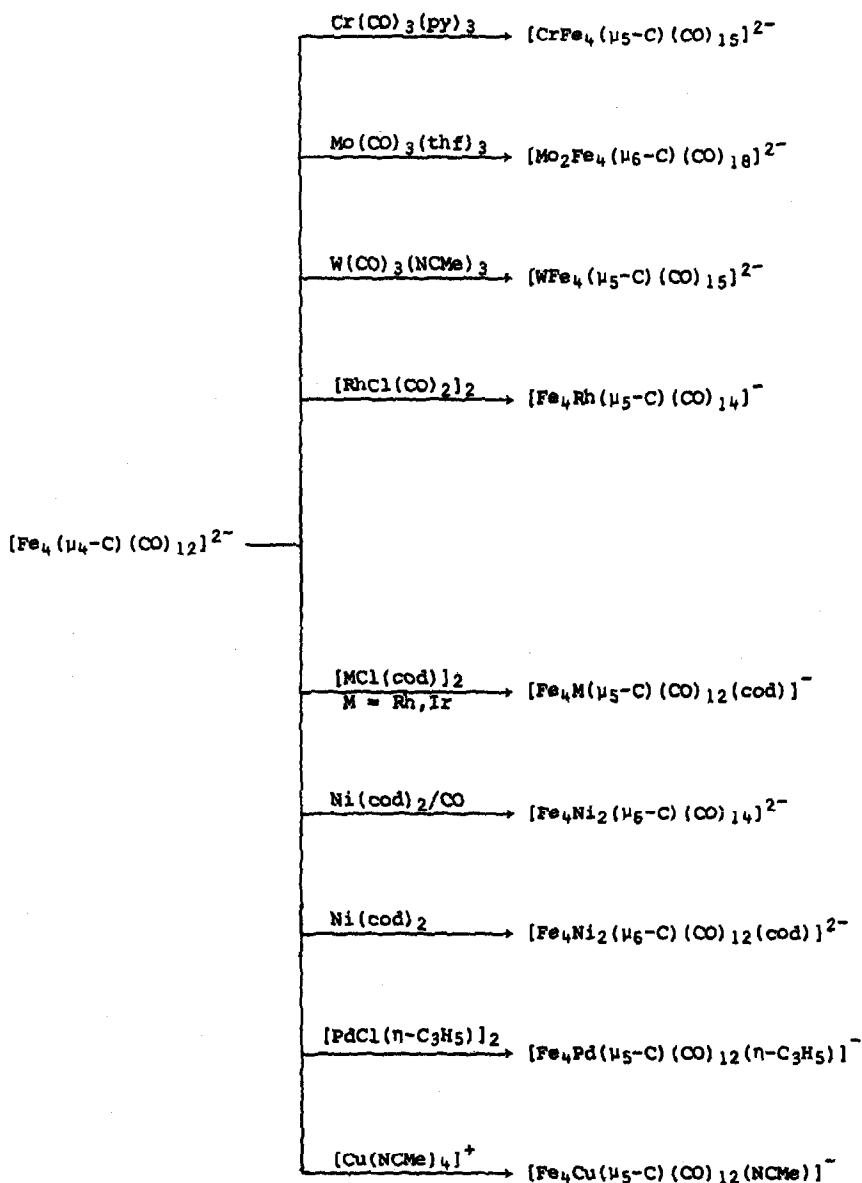

SCHEME 7 Syntheses of heteronuclear metal carbide clusters from  
 $[\text{Fe}_5(\mu_5\text{-C})(\text{CO})_{14}]^{2-}$

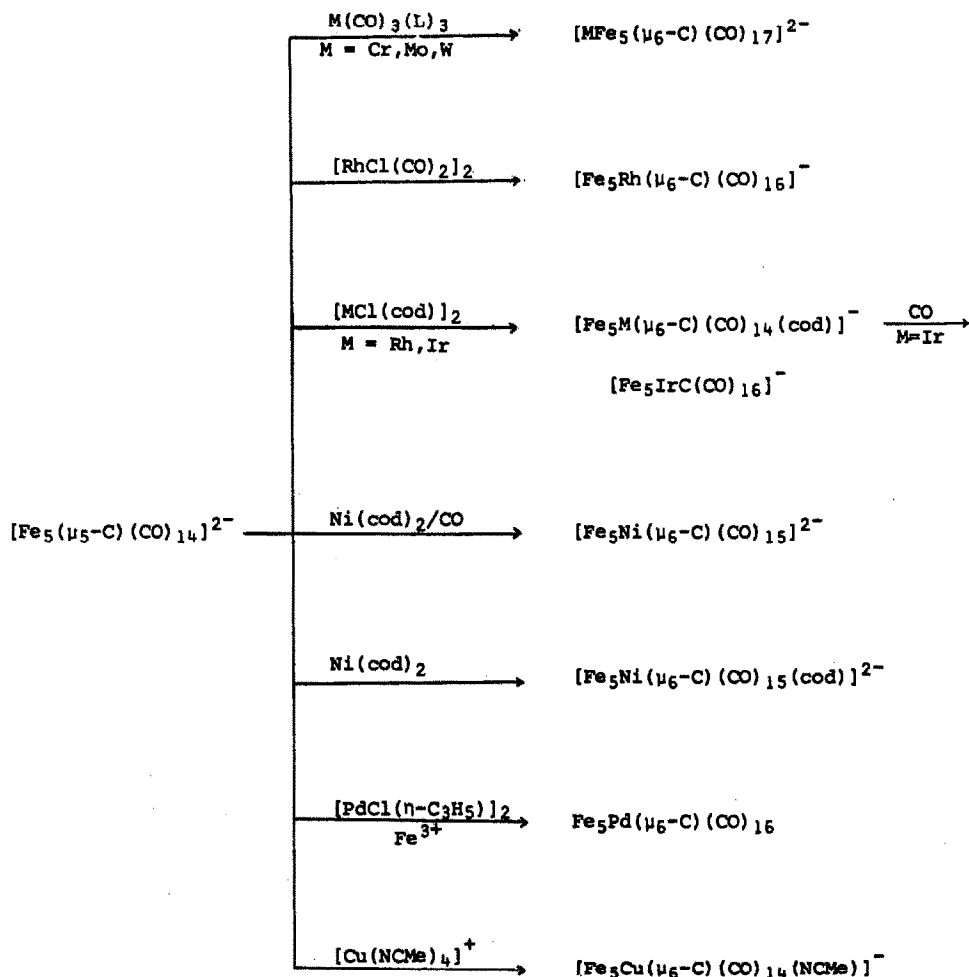

hydrid. Finally, gold-metal bonds are polar, and the electron density distribution on the transition metal seems to be intermediate between that in the hydride, and in the derived anion. It will be interesting to see how far this analogy can be pressed, and how reliable a guide to the location of a hydride ligand is provided by the structure of the corresponding  $\text{Au}(\text{PR}_3)$  derivative.

The deep red  $\text{VAu}_3$  cluster (59) has been obtained from  $[\text{V}(\text{CO})_5]^{3-}$  and  $\text{AuCl}(\text{PPh}_3)$  in thf; the metal core is a distorted tetrahedron, and the complex has been related to the hypothetical  $[\text{Au}(\text{PPh}_3)]_4$  [71]. The compound is the first mixed-metal cluster containing vanadium.

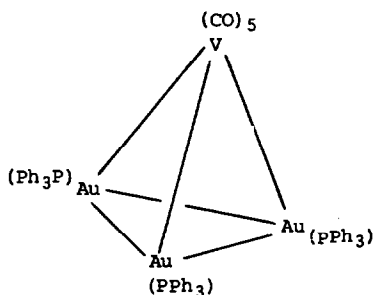

(59)

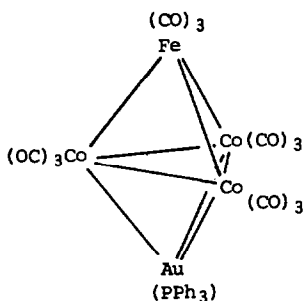

(60)

Direct reaction of  $[\text{FeCo}_3(\text{CO})_{12}]^-$  with  $\text{Au}(\text{NO}_3)(\text{PPh}_3)$  afforded (60), in which the  $\text{Au}(\text{PPh}_3)$  group caps the  $\text{Co}_3$  face, as found with the corresponding hydride [70].

A decade ago, the reaction between  $\text{Os}_3(\text{CO})_{12}$  and  $\text{AuX}(\text{PPh}_3)$  ( $\text{X} = \text{Cl}, \text{Br}, \text{I}, \text{SCN}$ ) was reported to give  $\text{Os}_3\text{AuX}(\text{CO})_{10}(\text{PPh}_3)$ , and preliminary X-ray studies showed that one edge of the  $\text{Os}_3$  triangle was bridged by  $\text{Au}(\text{PPh}_3)$  and X groups [72]. More recently, a second route to complexes of this type was found in the reaction between  $[\text{HOs}_3(\text{CO})_{11}]^-$  and  $\text{AuCl}(\text{PR}_3)$  ( $\text{R} = \text{Ph}$  or  $\text{Et}$ ), in the presence of  $\text{TiPF}_6$  (to remove Cl) which affords green  $\text{HOs}_3\text{Au}(\text{CO})_{10}(\text{PR}_3)$  [61;  $\text{R} = \text{Et}$  (62%),  $\text{Ph}$  (64%)]. In these complexes, both the H and  $\text{Au}(\text{PR}_3)$  ligands are one-electron donors, making (61) 58-electron clusters; the short bridged  $\text{Os}(1)\text{-Os}(2)$  bond [ $2.699(1)\text{\AA}$ ] is in accord with the idea of the cluster unsaturation being localised on this bond [cf also  $\text{H}_2\text{Os}_3(\text{CO})_{10}$ , where the "unsaturated" H-bridged Os-Os separation is  $2.683(1)\text{\AA}$ ]. Comparison with  $\text{Os}_3\text{Au}(\mu\text{-SCN})(\text{CO})_{10}(\text{PPh}_3)$  (62), also studied structurally, shows that the bridged  $\text{Os}(1)\text{-Os}(2)$  bond in this instance is  $0.2\text{\AA}$  longer, at  $2.899(1)\text{\AA}$ . A further interesting structural feature in (62) is the



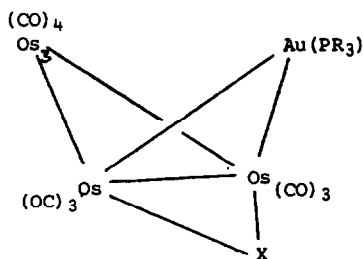

(61) X = H

(62) X = SCN

weak interaction [3.22Å] between an axial CO on Os(3) and the Au atom.

Complex (62) reacts with [ppn]Cl (refluxing  $\text{CH}_2\text{Cl}_2$ , 30 min) to give dark green [ppn][ $\text{H}_2\text{Os}_6\text{Au}(\text{CO})_{20}$ ] (63); an Au-P bond is cleaved in the reaction [74]. The hydride ligands are probably bridging the Os-Os bonds which interact with the Au atom; as with (62), the cluster is unsaturated, this being reflected in the short bridged Os-Os bonds [2.698(1)Å].

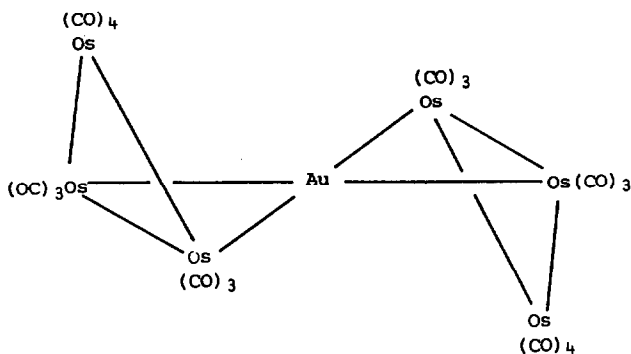

(63)

Exchange reactions between  $\text{Os}_3\text{Au}(\mu\text{-Cl})(\text{CO})_{10}(\text{PPh}_3)$  or  $\text{HAuOs}_3(\text{CO})_{10}(\text{PPh}_3)$  and  $\text{PPh}_2$ -functionalised poly(styrene-divinylbenzene) gave the corresponding polymer-supported clusters. Only the former catalysed ethylene hydrogenation (1 atm,  $<100^\circ$ ) [51].

The reaction between  $\text{Li}[\text{Co}(\text{CO})_4]$  and  $[\text{Au}_8(\text{PPh}_3)_7](\text{NO}_3)_2$  affords red-brown  $\text{Co}_2\text{Au}_6(\text{CO})_8(\text{PPh}_3)_4$  (64). The  $\text{Au}_6$  skeleton consists of two edge-sharing tetrahedra, and the  $[\text{Co}(\text{CO})_4]$  groups are attached to one apical Au in each tetrahedron [75].

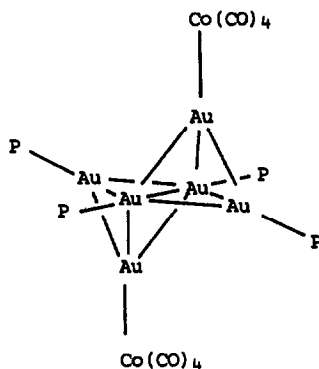

(64)

The yellow mixed Cu-Au cluster  $\text{Cu}_2\text{Au}_2(\text{C}_6\text{H}_4\text{CH}_2\text{NMe}_2)_4$  (65) has been prepared from  $\text{Li}_2\text{Au}_2(\text{C}_6\text{H}_4\text{CH}_2\text{NMe}_2)_4$  and  $\text{CuI}$  [76]. In solution, the tetra-nuclear structure is retained, and the mass spectrum contains the parent and fragment ions  $[\text{Cu}_2\text{Au}_2(\text{C}_6\text{H}_4\text{CH}_2\text{NMe}_2)_n]^+$  ( $n = 4, 3$ ). NMR studies show that the complex is fluxional, probably as a result of aryl group rotation with only weak M-N coordination; interaggregate exchange may occur in pyridine. In the presence of  $\text{PPh}_3$ , cluster fragmentation and reassembly afford  $\text{Cu}_4\text{Ar}_4$  and  $\text{AuAr}(\text{PPh}_3)$  ( $\text{Ar} = \text{C}_6\text{H}_4\text{CH}_2\text{NMe}_2$ ).

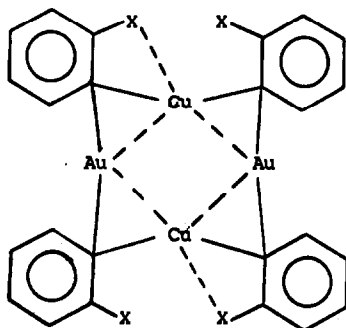
(65) X =  $\text{CH}_2\text{NMe}_2$ 

Mixed Ag-Au complexes are obtained from the reaction between  $\text{AgClO}_4$  and  $[\text{NBu}_4][\text{Au}(\text{C}_6\text{F}_5)_2]$ , followed by addition of ligands L ( $\text{L} = \text{py}, \text{PMePh}_2$ , pyridine-*N*-oxide, tetrahydrothiophen) [77]. The yellow intermediate formed initially is supposed to be  $\text{Ag}(\text{C}_6\text{F}_5)_2\text{Au}$ , while in donor solvents, the complexes afford  $[\text{AgL}_2][\text{Au}(\text{C}_6\text{F}_5)_2]$  with a second mole of L. The structure of

the mono-tetrahydrothiophen complex (66) shows an infinite chain structure with repeating  $\text{Ag}_2\text{Au}_2(\text{C}_6\text{F}_5)_4(\text{L})_2$  units linked by short Au---Au interactions [2.889(2)Å].

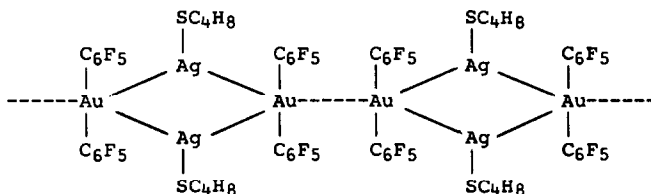

## 5. HETEROMETALLIC CLUSTER COMPLEXES CONTAINING BRIDGING CARBENE, ALKYLIDYNE, ALKYNE OR RELATED LIGANDS

The extensive studies by Stone and coworkers of the reactions of carbene and carbyne complexes with low-valent metal complexes have afforded a variety of heterobinuclear complexes (described in Part A), and also several heteronuclear cluster complexes containing the carbene or carbyne unit holding the cluster together. In the latter instance, the many homonuclear alkylidyne complexes, particularly of the type  $\text{Co}_3(\mu_3\text{-CR})(\text{CO})_9$ , are structurally prototypical, but the rational stepwise agglomeration of up to three different metal atoms in the cluster represents a significant advance.

**Complexes with  $\mu$ -carbene ligands**      The reactions between  $\text{M}[\text{C}(\text{OMe})\text{Ph}](\text{CO})_5$  ( $\text{M} = \text{Cr}, \text{Mo}, \text{W}$ ) and  $\text{Pt}(\eta\text{-C}_2\text{H}_4)(\text{PR}_3)_2$  ( $\text{R}_3 = \text{Me}_3$  or  $\text{Me}_2\text{Ph}$ ) afford "dimetallacyclopropane" complexes; use of  $\text{Pt}(\eta\text{-C}_2\text{H}_4)_2(\text{PR}_3)$  in these reactions results in further metal-metal bond formation, with ligand migration [78]. Thus the Group VI carbene complexes react with  $\text{Pt}(\eta\text{-C}_2\text{H}_4)_2(\text{PR}_3)$  ( $\text{PR}_3 = \text{PMeBu}_2^t$ ,  $\text{PCy}_3$ ) to give  $\text{MPt}_2[\mu\text{-C}(\text{OMe})\text{Ph}](\text{CO})_6(\text{PR}_3)_2$  (67;  $\text{M} = \text{Cr}, \text{W}$ ); in the chromium case, the product is accompanied by homonuclear  $\text{Pt}_2$  and  $\text{Pt}_3$  complexes. Similar reactions with  $\text{Mn}[\text{C}(\text{OMe})\text{Ph}](\text{CO})_2(\eta\text{-C}_5\text{H}_5)$  gave trinuclear platinum carbene cluster complexes. The carbene ligand bridges the Pt-Pt vector, while the M-Pt bonds are semi-bridged by CO groups. A possible route to com-

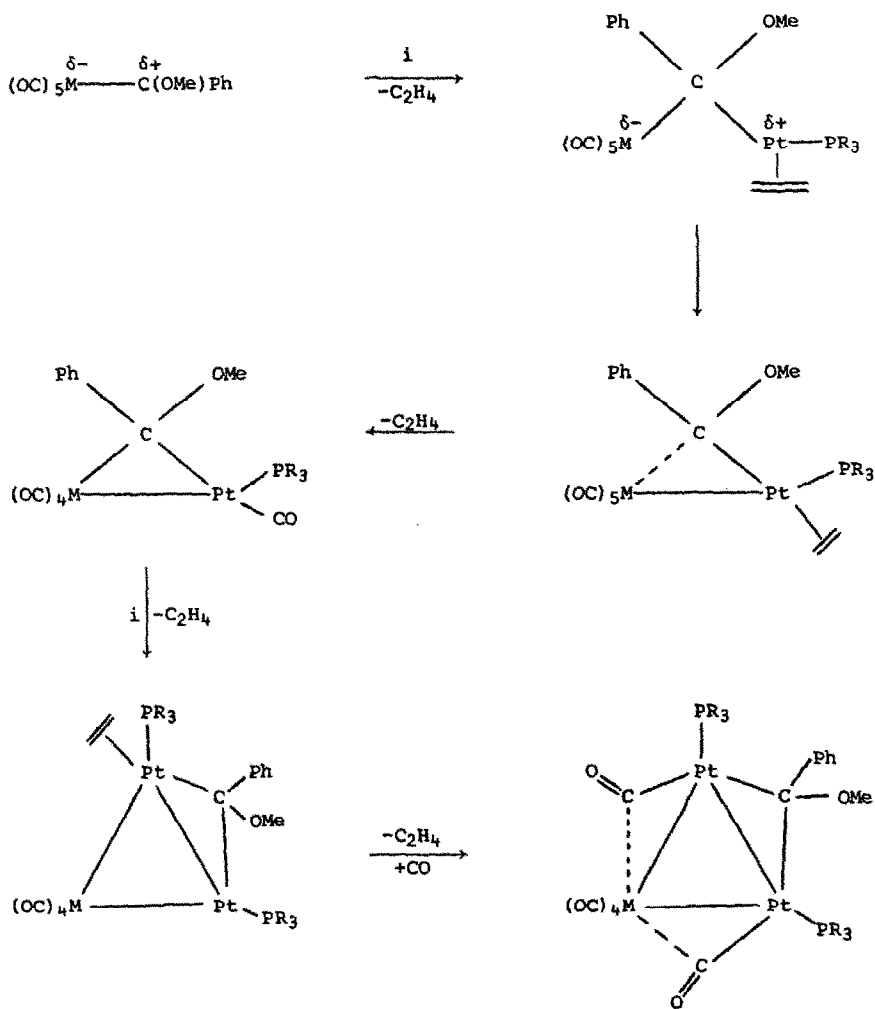
SCHEME 8 Formation of MPt<sub>2</sub>-η-carbene clusters

(67)	M	PR <sub>3</sub>
	Cr	PMeBu <sub>2</sub> <sup>t</sup>
	Cr	PCy <sub>3</sub>
	W	PMeBu <sub>2</sub> <sup>t</sup>
	W	PCy <sub>3</sub>

Reagents: *i*, Pt(η-C<sub>2</sub>H<sub>4</sub>)<sub>2</sub>(PR<sub>3</sub>)

plexes of type (67) is shown in Scheme 8; the heterobinuclear complexes have the carbene ligand lies closer to the platinum atom than to the Group VI metal, and the suggested insertion of the  $\text{Pt}(\eta\text{-C}_2\text{H}_4)(\text{PR}_3)$  fragment into this bond would thus be facilitated.

Similar complexes can be obtained from  $\text{Pt}(\text{PMeBu}_2^t)_2$ ; for example, at  $-60^\circ$ , the reaction with  $\text{W}[\text{C}(\text{OMe})\text{Ph}](\text{CO})_5$  affords (68).

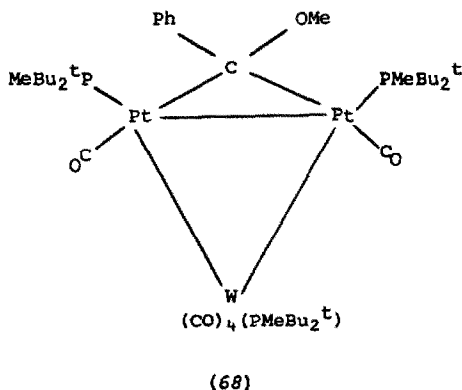

The trimetallic complexes  $\text{M}\{\text{W}[\mu\text{-C}(\text{tol})](\text{CO})_2(\eta\text{-C}_5\text{H}_5)\}_2$  ( $\text{M} = \text{Ni}, \text{Pd}, \text{Pt}$ ) are obtained from  $\text{W}[\text{C}(\text{tol})](\text{CO})_2(\eta\text{-C}_5\text{H}_5)$  and  $\text{Ni}(\text{cod})_2$ ,  $\text{Pd}(\eta^2\text{-C}_7\text{H}_{10})_3$  or  $\text{Pt}(\eta\text{-C}_2\text{H}_4)_3$ , respectively [79]. They contain bent  $\text{W-M-W}$  sequences bridged by the  $\mu$ -alkylidyne ligands, and have been discussed in detail in Part A.

Diazomethane reacts with  $(\mu\text{-H})_2\text{Os}_3\text{Pt}(\text{CO})_{10}(\text{PCy}_3)$  (33;  $\text{R}_3 = \text{Cy}_3$ ) under kinetic control to give orange  $(\mu\text{-H})_2\text{Os}_3\text{Pt}(\mu\text{-CH}_2)(\text{CO})_{10}(\text{PCy}_3)$  (69a), which after several days in solution isomerises to the red unsymmetrical isomer (69b); both isomers were characterised by X-ray studies [80]. Complex (69a) is also formed directly from  $\text{H}_2\text{Os}_3(\mu\text{-CH}_2)(\text{CO})_{10}$  and  $\text{Pt}(\eta\text{-C}_2\text{H}_4)_2(\text{PCy}_3)$ . Labelling studies showed that ca 30-40% of deuterium is transferred from the initial  $\mu\text{-D}$  or  $\mu\text{-CD}_2$  sites (Scheme 9).

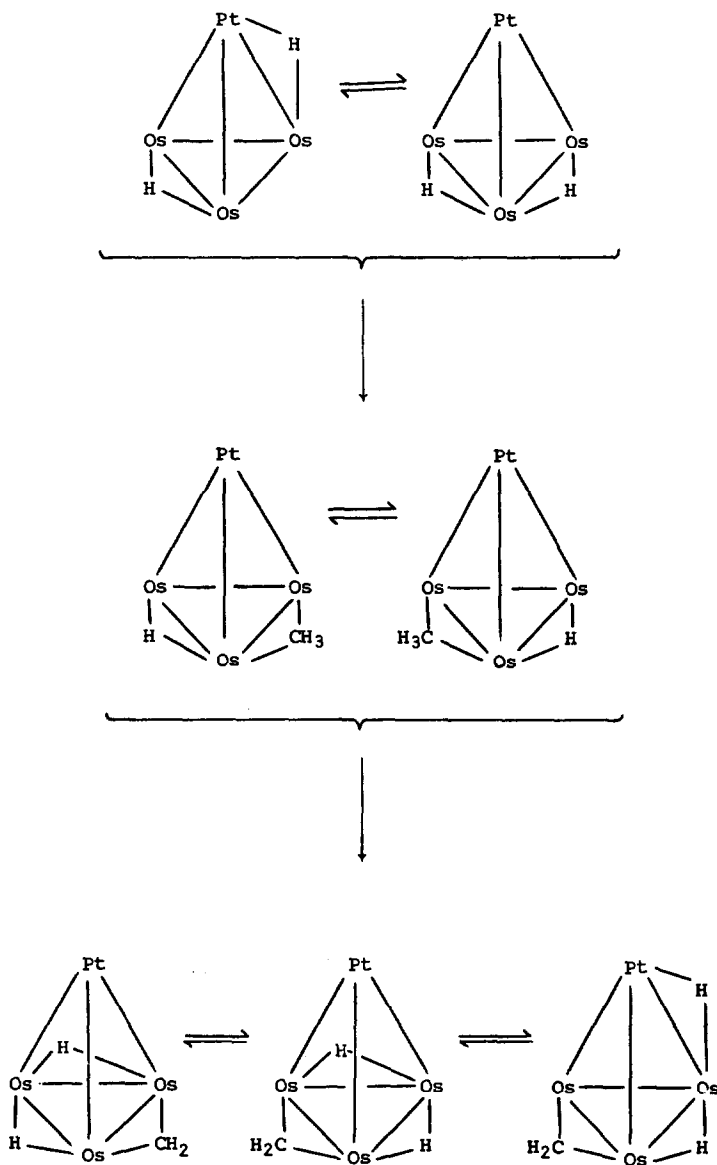
SCHEME 9 Formation of a  $\mu$ -methylene- $\text{Os}_3\text{Pt}$  complex

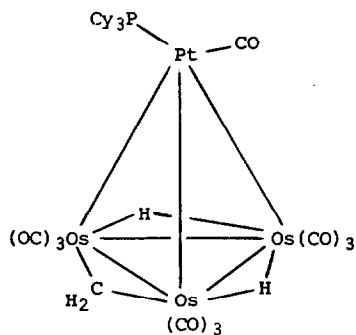

(69a)

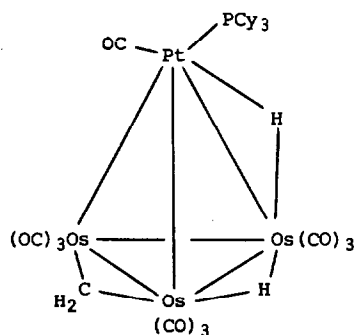

(69b)

$\mu_3$ -Alkylidyne complexes      The isolobal relationship between  $W(CO)_2(\eta-C_5H_5)$  and CH prompted the investigation of reactions between  $W[C(tol)](CO)_2(\eta-C_5H_5)$  (as an alkyne analogue) and several metal carbonyls; among the products were several mixed-metal  $\mu_3$ -alkylidyne complexes.

The initial product from the reaction between the carbyne complex and  $Fe_2(CO)_9$  is  $WFe[\mu-C(tol)](CO)_6(\eta-C_5H_5)$ ; with excess of  $Fe_2(CO)_9$ , further addition of  $Fe(CO)_3$  occurs rapidly to give (70) [81]. This complex reacts with alkynes to give  $WFe[\mu-C(tol)CRCR](CO)_5(\eta-C_5H_5)$  ( $R = Me, Ph, tol, CF_3$ ) in which the alkyne has linked up with the alkylidyne group to form a  $\mu-C_3$  unit, with concomitant loss of an  $Fe(CO)_3$  group [82]. In contrast, cluster degradation did not occur in reactions with  $C_2(SiMe_3)_2$  or  $Bu^tC_2SiMe_3$ , which gave complex (71;  $R = SiMe_3$ ) and an isomeric mixture of (71;  $R = Bu^t, R' = SiMe_3$  and  $R = SiMe_3, R' = Bu^t$ ), respectively.

Complex (72) was isolated from the reaction between  $W[C(tol)](CO)_2(\eta-C_5H_5)$  and  $Os_3(CO)_{10}(\eta^2-C_8H_{14})_2$  ( $C_8H_{14} =$  cyclooctene) [81].

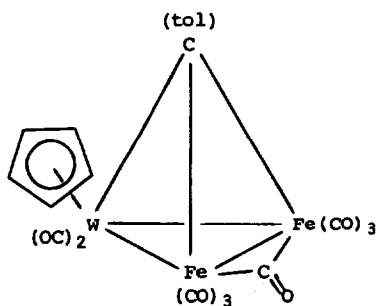

(70)

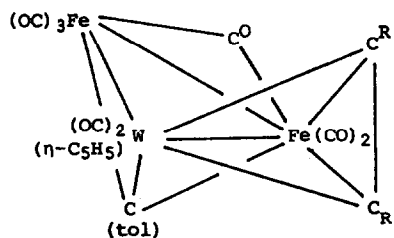

(71)

Reactions between  $W[C(tol)](CO)_2(\eta-C_5H_5)$  and  $Co_2(CO)_8$  or  $Rh_2(CO)_2(\eta-C_5Me_5)_2$  afford the purple trinuclear complexes (73) and (74), respectively, in 70-90% yield [83]. The complexes are isolobally related to complexes containing tetrahedral  $C_2M_2$  cores, obtained from alkynes and the dimetal precursors.

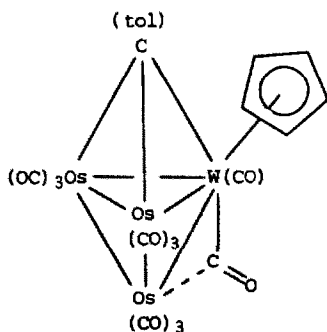

(72)

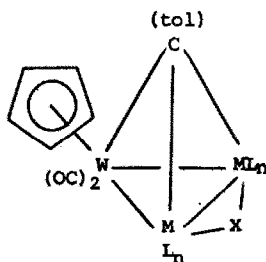
(73)  $ML_n = Co(CO)_3$ , X not present(74)  $ML_n = Rh(\eta-C_5Me_5)$ , X = CO

Complexes related to (73) had also been obtained from  $Co_3(\mu_3-CR)(CO)_9$  and  $[W(CO)_3(\eta-C_5H_5)]_2$  by direct exchange of metals [84]. This reaction has been extended to the syntheses of several mixed metal complexes (75-78) from  $Co_3(\mu_3-CMe)(CO)_9$  and binuclear carbonyls:

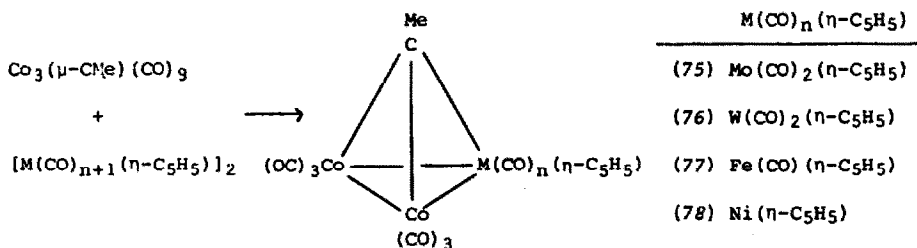

The reactions proceeded in low yield with the iron complex, and most readily with an excess of  $[Ni(CO)(\eta-C_5H_5)]_2$ ; in the latter case, complexes with  $\mu_3-C(CF_3)$  and  $\mu_3-CPh$  groups were also prepared [63].

The dark brown chiral cluster (79), which crystallises as optically active crystals, was obtained similarly from (75) and  $[Ni(CO)(\eta-C_5H_5)]_2$ .



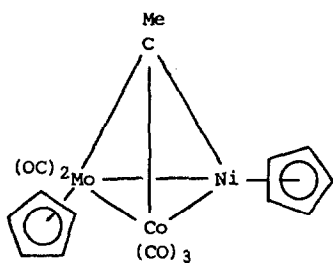

(79)

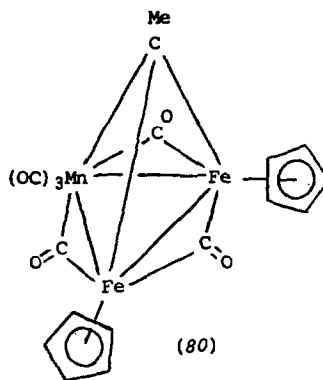

(80)

Formal addition of an H-Mn bond to the  $\mu$ -vinylidene ligand in  $\text{Fe}_2(\mu\text{-C}=\text{CH}_2)(\mu\text{-CO})(\text{CO})_2(\eta\text{-C}_5\text{H}_5)_2$  occurs on reaction with  $\text{H}_3\text{Mn}_3(\text{CO})_{12}$ , to give the black  $\text{MnFe}_2(\mu_3\text{-CMe})$  complex (80). In refluxing toluene, (59) is converted to  $\text{Fe}_3(\mu_3\text{-CMe})(\mu\text{-CO})_3(\eta\text{-C}_5\text{H}_5)_3$  [85].

The general synthesis of cluster complexes containing an alkylidyne group capping an  $\text{MM}'\text{M}''$  triangle consists of reaction between a mononuclear metal-alkylidyne (carbyne) complex and either two different low-valent metal derivatives in sequence, or with reactive dimetal compounds.

Black (81), containing a  $\text{CWFePt}$  cluster, was obtained from  $\text{Pt}(\eta\text{-C}_2\text{H}_4)(\text{PET}_3)_2$  (prepared *in situ*) and  $\text{W}[\text{C}(\text{tol})](\text{CO})_2(\eta\text{-C}_5\text{H}_5)$  [which gives  $\text{WPt}[\mu\text{-C}(\text{tol})](\text{CO})_2(\text{PET}_3)_2(\eta\text{-C}_5\text{H}_5)$ ], followed by addition of  $\text{Fe}_2(\text{CO})_9$ . A structural study showed that the alkylidyne ligand asymmetrically bridges the  $\text{WFePt}$  triangle. A similar reaction sequence commencing with  $\text{Pt}(\eta\text{-C}_2\text{H}_4)(\text{PMe}_2\text{Ph})_2$  gave (82), together with a small amount of (83), while purple (84) was formed from  $\text{WPt}[\mu\text{-C}(\text{tol})](\text{CO})_2(\text{PMe}_2\text{Ph})_2(\eta\text{-C}_5\text{H}_5)$  and  $\text{Fe}(\text{CO})_5$  or  $\text{Fe}_2(\text{CO})_9$  [83]. The  $^1\text{H}$ ,  $^{13}\text{C}$  and  $^{31}\text{P}$  NMR spectra showed the chiral nature of (84), and also that it was fluxional (CO site exchange). An  $\eta\text{-C}_5\text{H}_4\text{SiMe}_3$  analogue was also prepared.

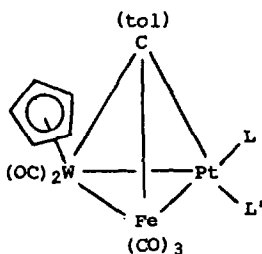
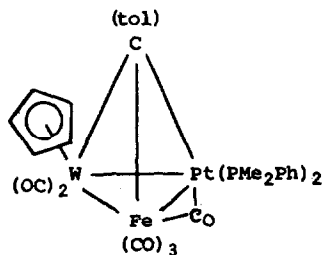
(81) L = CO, L' =  $\text{PET}_3$ (82) L = CO, L' =  $\text{PMe}_2\text{Ph}$ (83) L = L' =  $\text{PMe}_2\text{Ph}$ 

(84)

Similarly, treatment of  $\text{WRh}[\mu\text{-C}(\text{tol})](\text{CO})_3(\eta\text{-C}_5\text{H}_5)(\eta\text{-C}_9\text{H}_7)$  [from  $\text{W}[\text{C}(\text{tol})](\text{CO})_2(\eta\text{-C}_5\text{H}_5)$  and  $\text{Rh}(\text{CO})_2(\eta\text{-C}_9\text{H}_7)$ ] with  $\text{Fe}_2(\text{CO})_9$  affords purple (85), in which the Rh-Fe bond is bridged asymmetrically by CO [83].

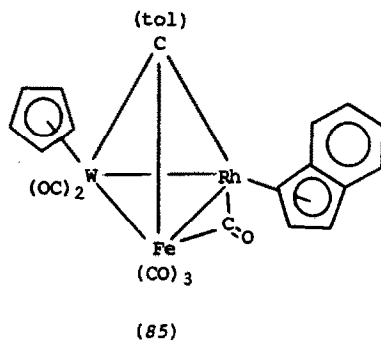

$\mu_3$ -Alkyne complexes      If an excess of  $\text{W}[\text{C}(\text{tol})](\text{CO})_2(\eta\text{-C}_5\text{H}_5)$  is present in the reaction with  $\text{Fe}_2(\text{CO})_9$  (see above), a second tungsten-containing moiety adds to the WFe intermediate to give (86). In this, two alkylidyne units have coupled to form the  $\text{C}_2(\text{tol})_2$  ligand, which lies with the C-C bond parallel to the W-Fe vector. Slow oxidation of (86) in the solid state affords (87) [81]. The Ru analogue, obtained from the tungsten-carbyne complex and  $\text{Ru}_3(\text{CO})_{12}$ , has the alkyne symmetrically bonded to the  $\text{W}_2\text{Ru}$  triangle. In the crystal of the corresponding  $\text{W}_2\text{Os}$  complex (88), obtained

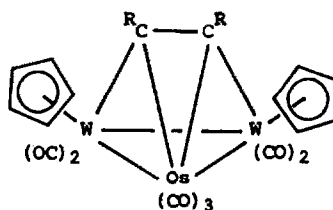
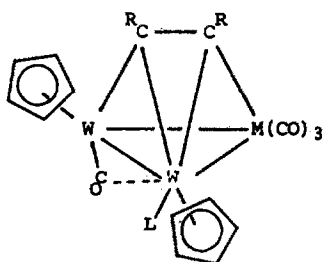

R = tol

(88a)

	M	L
(86)	Fe	CO
(87)	Fe	O
(88b)	Os	Co

similarly from  $\text{H}_2\text{Os}_3(\text{CO})_{10}$  [86] or  $\text{H}_2\text{Os}_3(\mu\text{-CH}_2)(\text{CO})_{10}$  [81], both isomers are present, and evidently are two of the three minimum energy states for alkyne rotation about the metal triangle; in solution, (88) is fluxional. Formation of (88) is accompanied by that of  $\text{H}_2\text{Os}_2(\text{CO})_8$  [detected by addition of  $\text{CCl}_4$  and subsequent isolation of  $\text{Os}_2\text{Cl}_2(\text{CO})_8$ ]:

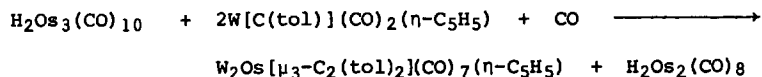

The source of the extra CO is presently unknown. A second heterometallic complex is also formed in this reaction, the dark red  $\text{WOs}_3[\mu_3\text{-COCH}_2(\text{tol})](\text{CO})_{11}(\eta\text{-C}_5\text{H}_5)$  (89), containing an almost planar  $\text{WOs}_3$  core. The formation of (89) must involve H transfer to the carbyne carbon, and migration of the alkyl group to CO.

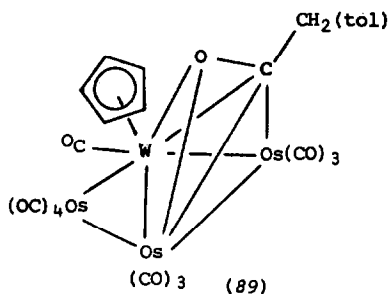

The first examples of mixed-metal clusters containing  $\text{M}_4\text{C}_2$  cores were obtained from the reactions of  $\text{H}_2\text{FeRu}_3(\text{CO})_{13}$  with alkynes: the black complexes  $\text{FeRu}_3(\mu_4\text{-RCCR}')(\text{CO})_{12}$  ( $\text{R}, \text{R}' = \text{Me}$  or  $\text{Ph}$ ;  $\text{R} = \text{Ph}$ ,  $\text{R}' = \text{Me}$ ) are formed in 40-65% yield [87]. The symmetrical alkynes form two isomers of these complexes, while three isomers of the cluster from  $\text{MeC}_2\text{Ph}$  were obtained. The two isomers of  $\text{FeRu}_3(\mu_4\text{-C}_2\text{Ph}_2)(\text{CO})_{12}$  (90a and b) were characterized by X-ray studies; they differ only in the arrangement of the metal atoms. Isomer a is converted to isomer b at elevated temperatures; for (90), the equilibrium mixture contains a 9/1 ratio of a and b. The former is thus the thermodynamically more stable compound, but isomer b is formed first in the reactions.

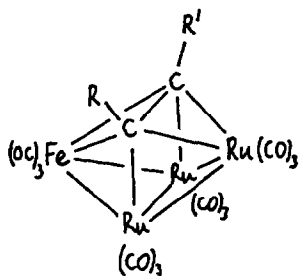

(90a)

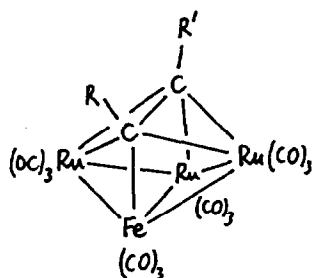

(90b)

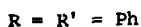

Reactions between alkynes, iron carbonyls and cyclopentadienyl-nickel complexes ( $\text{Ni}(\eta\text{-C}_5\text{H}_5)_2$  or  $[\text{Ni}(\text{CO})(\eta\text{-C}_5\text{H}_5)]_2$ ), or between iron carbonyls and  $\text{Ni}_2(\mu\text{-C}_2\text{R}_2)(\eta\text{-C}_5\text{H}_5)$ , have been a prolific source of mixed-metal complexes containing iron and nickel. Some idea of the complexity of these reactions can be obtained from the fact that 19 products were formed by heating equimolar amounts of  $\text{Fe}_3(\text{CO})_{12}$  and  $\text{Ni}_2(\mu\text{-HC}_2\text{Bu}^t)(\eta\text{-C}_5\text{H}_5)_2$  in refluxing hydrocarbon solvents. Table 1 summarises the mixed-metal derivatives so

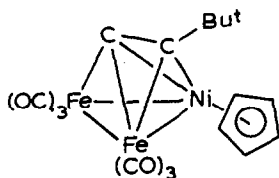

(91)

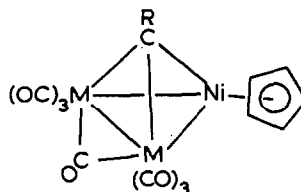

(92) M = Fe or Ru

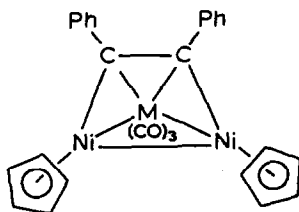

(93) M = Fe or Ru

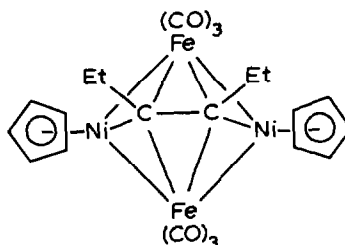

(94)

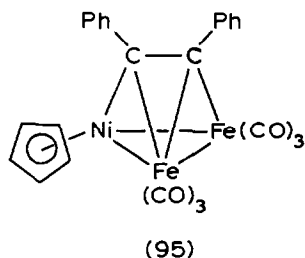

obtained. The structures of several complexes obtained from these and related reactions have been determined.

One of the products from the cited reaction is black  $\text{Fe}_2\text{Ni}(\mu_3\text{-C}_2\text{Bu}^t)\text{-(CO)}_6(\eta\text{-C}_5\text{H}_5)$  (91) (6%), which contains a distorted trigonal bipyramidal  $\text{Fe}_2\text{NiC}_2$  core, with Fe and C at the apices; also formed are trace amounts of  $\text{Fe}_2\text{Ni}[\mu_3\text{-C}(\text{CH}_2\text{Bu}^t)](\text{CO})_7(\eta\text{-C}_5\text{H}_5)$  (92;  $\text{R} = \text{CH}_2\text{Bu}^t$ ) [88]. The long-known  $\text{FeNi}_2(\mu_3\text{-C}_2\text{Ph}_2)(\text{CO})_3(\eta\text{-C}_5\text{H}_5)_2$  (93) and its ruthenium analogue have been structurally characterised; in these complexes a distorted square-planar  $\text{MNi}_2\text{C}_2$  ( $\text{M} = \text{Fe}$  or  $\text{Ru}$ ) core is present [61]. The tetranuclear  $\text{Fe}_2\text{Ni}_2(\mu_4\text{-C}_2\text{R}_2)(\text{CO})_6(\eta\text{-C}_5\text{H}_5)_2$  complexes have also been known for nearly twenty years, and the structure of the ethyl derivative (94) has now been determined [60]. It is unusual in containing an open  $\text{Fe}_2\text{Ni}_2$  cluster, with the alkyne interacting with all four metal atoms.

Addition of  $\text{P}(\text{OMe})_3$  or  $\text{PMe}_3$  to the long-known  $\text{Fe}_2\text{Ni}_2(\mu_4\text{-C}_2\text{Ph}_2)\text{-(CO)}_6(\eta\text{-C}_5\text{H}_5)$  results in an unusual extrusion of an  $\text{Ni}(\eta\text{-C}_5\text{H}_5)$  group from the cluster: the product is the  $[\text{Ni}(\text{PR}_3)_2(\eta\text{-C}_5\text{H}_5)]^+$  ( $\text{R} = \text{OMe}, \text{Me}$ ) salt of the  $[\text{Fe}_2\text{Ni}(\mu_3\text{-C}_2\text{Ph}_2)(\text{CO})_6(\eta\text{-C}_5\text{H}_5)]^-$  anion (95). In this, the alkyne is attached to the  $\text{Fe}_2\text{Ni}$  cluster in the  $(2\sigma, \pi)$  mode, with the C-C bond parallel to one of the Fe-Ni vectors [89].

Extension of these reactions to ruthenium carbonyls has also given complex mixtures (Table 1). Thus, the reaction between  $\text{Ru}_3(\text{CO})_{12}$  and  $\text{Ni}_2(\mu\text{-C}_2\text{Ph}_2)(\eta\text{-C}_5\text{H}_5)_2$  in refluxing octane (20 min) affords two isomers of  $\text{Ru}_2\text{Ni}(\mu_3\text{-C}_2\text{Ph}_2)(\text{CO})_4(\eta\text{-C}_5\text{H}_5)$  (96) in about 10% yield [90]. Grey-green (96a) was characterised by an X-ray study, and contains an asymmetric triply-bridging CO group, rendering the complex chiral; IR studies of dark violet (96b) suggest that it differs in containing a  $\mu_2\text{-CO}$  ligand.





Fifteen other products are formed: in addition to the ruthenium analogue of (93), the cluster complexes include the tetranuclear  $\text{Ru}_3\text{Ni}(\mu\text{-C=CHBu}^\dagger)(\text{CO})_9(\eta\text{-C}_5\text{H}_5)$  and  $\text{Ru}_3\text{Ni}(\text{C}_6\text{H}_9)(\text{CO})_8(\eta\text{-C}_5\text{H}_5)$  (see below) which have been characterised by X-ray studies, and  $\text{Ru}_3\text{Ni}(\mu_4\text{-C}_2\text{Ph}_2)(\text{CO})_9(\eta\text{-C}_5\text{H}_5)$ , proposed to be (97) on the basis of its spectroscopic properties.

Five complexes were obtained from the reaction between  $\text{C}_2\text{Me}_2$  and  $(\mu\text{-H})\text{Os}_3\text{Pt}(\text{CO})_{10}(\text{PPh}_3)$ , of which bright yellow (98;  $\text{L} = \text{PPh}_3$ ) was isolated directly, and characterised by an X-ray study. In this compound, the Pt-Pt bond is long [3.033(2)Å], and the weakened interaction resulting therefrom may also be reflected in the low  $J(\text{PtPt})$  of 57Hz. Chromatographic separation of the mother liquor afforded small amounts of the related complex (98;  $\text{L} = \text{CO}$ ), together with the homonuclear derivatives  $\text{Os}_2(\text{CO})_6(\text{C}_4\text{Me}_4)$ ,  $\text{H}_2\text{Os}_3(\mu_3\text{-C}_2\text{Me}_2)(\text{CO})_8(\text{L})$  ( $\text{L} = \text{CO}$  and  $\text{PPh}_3$ ) [50].

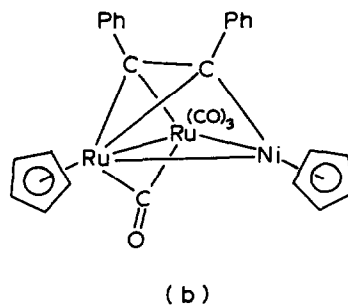
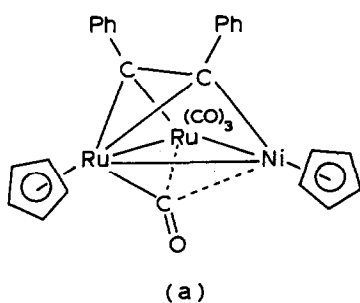

(96)

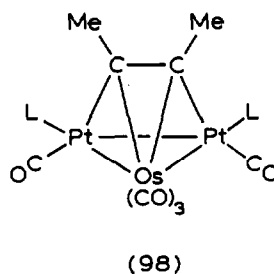
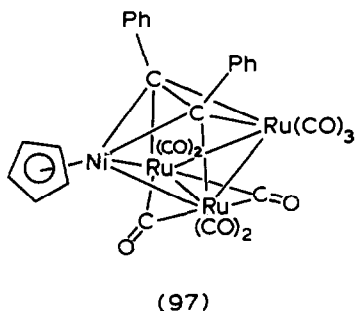



## 6. HETERONUCLEAR CLUSTERS CONTAINING OTHER BRIDGING HYDROCARBON LIGANDS

The vinylidene complex  $\text{Fe}_2(\mu\text{-C}=\text{CH}_2)(\mu\text{-CO})(\text{CO})_2(\eta\text{-C}_5\text{H}_5)$  reacts with  $\text{Co}_2(\text{CO})_8$  to give the  $\text{FeCo}_3$  derivative (99), in which the  $\text{C}=\text{CH}_2$  ligand now bridges all four metal atoms [85].

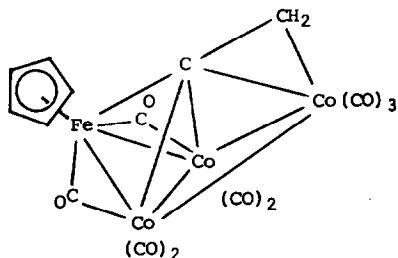

(99)

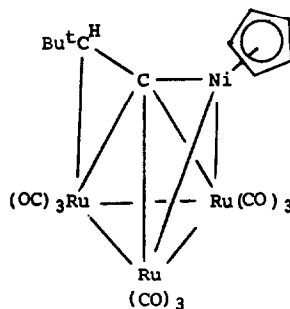

(100)

Conversion of the  $\mu_3$ -acetylide group in  $\text{HRu}_3(\mu_3\text{-C}_2\text{Bu}^t)(\text{CO})_9$  to a  $\mu_4$ -vinylidene ligand occurs on reaction with  $[\text{Ni}(\text{CO})(\eta\text{-C}_5\text{H}_5)]_2$ . The product, black  $\text{Ru}_3\text{Ni}(\mu_4\text{-C}=\text{CHBu}^t)(\text{CO})_9(\eta\text{-C}_5\text{H}_5)$  (100) has the  $\text{Ni}(\eta\text{-C}_5\text{H}_5)$  group capping a  $\text{Ru}_3\text{C}$  face. As found with (99), one carbon atom of the vinylidene ligand interacts with all four metal atoms [Ni-C, 1.834(8); Ru-C, 2.156, 2.159, 2.176(9) Å] [91].

Tetranuclear Ru-Ni clusters have been prepared from  $\text{HRu}_3(\mu_3\text{-MeCCHR})\text{-}(\text{CO})_9$  (R = Me, Et) and  $[\text{Ni}(\text{CO})(\eta\text{-C}_5\text{H}_5)]_2$ ; for R = Et, two isomeric products are formed [92]. A X-ray study of one isomer of  $\text{Ru}_3\text{Ni}(\mu_4\text{-MeCCHCt})\text{-}(\text{CO})_8(\eta\text{-C}_5\text{H}_5)$  (101) shows that the  $\text{C}_3$  ligand bridges the Ru-Ni hinge of the  $\text{Ru}_3\text{Ni}$  butterfly core; the isomerism arises from the different substituents on the carbons attached to Ru and Ni.

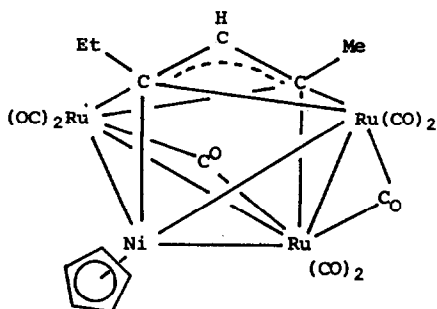

(101)



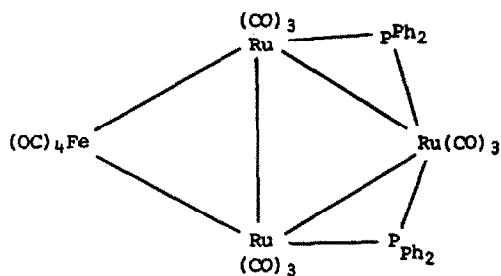

(106)

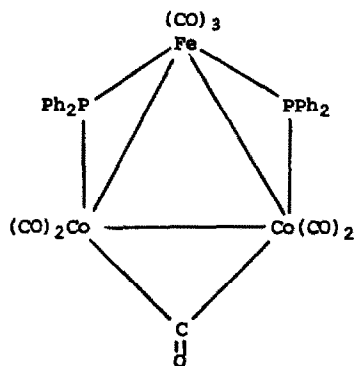

(107)

The reaction between  $\text{Fe}(\text{CO})_4(\text{P}_2\text{Ph}_4)$  and  $\text{Co}_2(\text{CO})_8$  affords  $\text{FeCo}_2(\mu\text{-PPh}_2)_2(\mu\text{-CO})(\text{CO})_7$  (107) in high yield; a minor by-product is  $\text{FeCo}(\mu\text{-PPh}_2)(\text{CO})_7$  [96]. The Fe-Co bond lengths are unequal [2.530(2), 2.615(2) Å], and one of the CO ligands on the further Co is considered to be "incipiently semi-bridging" the Co-Co bond. The CO groups are fluxional by (i) two turnstile rotations, one on each Co; (ii) bridge-terminal exchange on Co; (iii) exchange of all CO's over all sites (at  $-15^\circ\text{C}$ ). In MeCN, three 1e reduction waves were observed; sodium amalgam afforded a reduced species which regenerated (115) on protonation.

The isomeric mixture of *syn*-/*anti*- $[\text{Fe}(\mu\text{-SMe})(\text{CO})_3]_2$  reacts with  $\text{P}(\text{HMe})_2$ , and subsequently  $\text{Co}(\text{CO})_3(\eta\text{-C}_3\text{H}_5)$ , to give brown-black  $\text{Fe}_2\text{Co}(\mu\text{-PMe}_2)(\mu\text{-SMe})_2(\text{CO})_8$  (108) (50%), which has an open  $\text{Fe}_2\text{Co}$  triangle [97]. Formation of (108) results from the usual propene-elimination reaction, which is followed by insertion of the  $\text{Co}(\text{CO})_3$  moiety into the Fe-Fe bond, transfer of CO from Co to Fe, and rearrangement of all bridging groups.

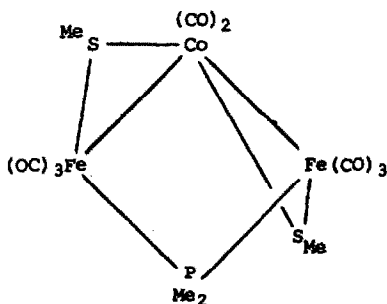

(108)

One of the products obtained by reaction between  $\text{Fe}(\text{CO})_4(\text{PPh}_2)$  and  $[\text{RhCl}(\text{CO})_2]_2$  in the presence of base is black  $\text{FeRh}_3(\mu\text{-PPh}_2)_3(\text{CO})_8$  (109a) [98]. The  $\text{FeRh}_3$  core adopts a butterfly arrangement; one Rh atom has a formal 16-electron configuration. Complex (109a) rearranges in solution to a second isomer, probably (109b). Treatment of the latter with CO gives  $[\text{Rh}(\mu\text{-PPh}_2)(\text{CO})_3]_2$ .

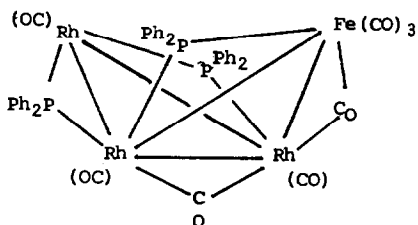

(109a)

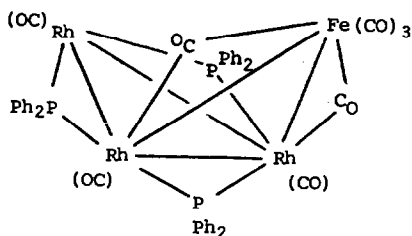

(109b)

Clusters containing  $\mu_3\text{-E}$  ( $\text{E} = \text{S}, \text{Se}, \text{PR}, \text{AsR}, \text{SiR}_2, \text{GeR}_2$ ) bridging units

Construction of clusters containing homo- or hetero-metallic units can be facilitated if S or PR moieties are present as bridging ligands, and this may be accomplished using suitable precursors containing S-S or H-P bonds, which can react with other metal carbonyls, for example.

Reaction of  $\text{Fe}_2(\mu\text{-S}_2)(\text{CO})_6$  with  $[\text{Cr}(\text{CO})_3(\eta\text{-C}_5\text{H}_5)]_2$  affords the greenish-black tetranuclear derivative  $\text{Cr}_2\text{Fe}_2(\mu_3\text{-S})_2(\mu_3\text{-CO})_2(\text{CO})_8(\eta\text{-C}_5\text{H}_5)_2$  (110) [99]. Two  $\text{Cr}_2\text{Fe}$  rings of the butterfly core are capped by sulphur, while CO ligands attached to each Cr each bend towards the two Fe atoms in a semi-triply bridging mode.

With  $\text{Mn}_2(\text{CO})_{10}$  in thf, the iron-sulphur complex afforded the black complex  $\text{Mn}_2\text{Fe}_2\text{S}_2(\text{CO})_{14}$  (111; 97%). The X-ray structure, while not unambiguously distinguishing between Mn and Fe, and Mössbauer data strongly indicate the structure shown; one of the CO groups semi-bridges the two iron atoms [100]. The Se analogue has also been prepared.

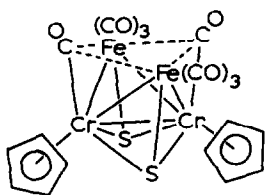

(110)

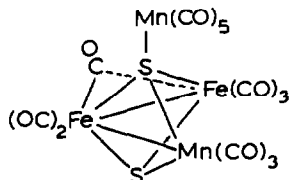

(111)

Interaction of  $\text{Co}_2(\text{CO})_8$  with  $\text{Fe}_2(\mu\text{-S}_2)(\text{CO})_6$  or with  $\text{Fe}_2(\mu\text{-PPh})_2(\text{CO})_6$  afforded the black  $\text{Fe}_2\text{Co}_2$  clusters (112) and (113), respectively [101]. Structurally, these complexes are very similar, and are analogous to the homometallic  $\text{Co}_4(\mu_4\text{-E})_2(\text{CO})_{10}$  ( $\text{E} = \text{S}, \text{PPh}$ ).

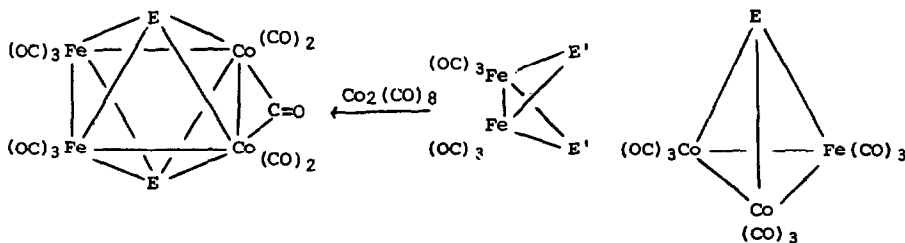
(112)  $\text{E} = \text{S}$  $\text{E}'\text{-E}' = \text{S-S}$ (114)  $\text{E} = \text{S}$ (113)  $\text{E} = \text{PPh}$  $\text{E}' = \text{HPPh}$ (115)  $\text{E} = \text{Se}$ 

Previously, the reaction of  $\text{Fe}_2(\mu\text{-S}_2)(\text{CO})_6$  with  $\text{Co}_2(\text{CO})_8$  at room temperature had been reported to give (114) in 56% yield [102]; an almost quantitative yield of this complex was obtained when the mixture was UV irradiated [103]. Electrochemical ( $\text{E}_{1/2} = -0.24\text{V}$  vs  $\text{Ag}/\text{AgCl}$ ) or alkali metal reduction of (114) affords the radical anion  $[\text{FeCo}_2\text{S}(\text{CO})_9]^-$ , which has a half-life of ca 1 min; further reduction is irreversible and results in cluster fragmentation [104]. Electrode reactions of the cluster are characterised by strong absorption phenomena, probably associated with electron transfer via the S atom; the phenomena were absent in  $\text{FeCo}_2\text{-}[\mu_3\text{-SCr}(\text{CO})_5](\text{CO})_9$ . Substitution of CO by  $\text{P}(\text{O}^i\text{Pr})_3$  reduces the reduction potential ( $\text{E}_{1/2} -0.86\text{V}$  vs  $\text{Ag}/\text{AgCl}$ ). The ESR spectrum of the parent radical anion was interpreted in terms of mixing of about 19% Co  $3d_{z^2}$  into the

LUMO antibonding orbital which is mainly  $3d_{xy}$  in the  $\text{Co}_3\text{S}$  clusters; approximately 60% of the spin density resides on the Co atoms.

The reaction between  $\text{Fe}_2(\mu\text{-Se}_2)(\text{CO})_6$  and  $\text{Co}_2(\text{CO})_8$  afforded on irradiation black (115) in 95% yield [103].

An  $\text{FeNi}_2\text{S}$  cluster is obtained from  $\text{Fe}_2(\mu\text{-S}_2)(\text{CO})_6$  and  $[\text{Ni}(\text{CO})-(\eta\text{-C}_5\text{H}_5)]_2$  in 15% yield; dark brown  $\text{FeNi}_2(\mu_3\text{-S})(\text{CO})_3(\eta\text{-C}_5\text{H}_5)$  has structure (116) [105].

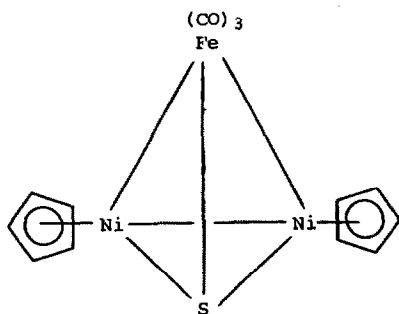

(116)

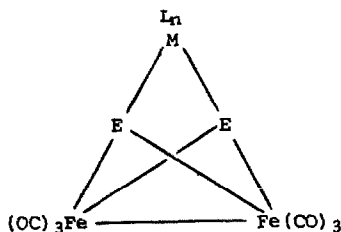

(117)

In contrast, quantitative yields of  $\text{Fe}_2(\text{CO})_6(\mu_3\text{-E})_2\text{M}(\text{PPh}_3)_2$  [117;  $\text{E} = \text{S}, \text{Se}, \text{Te}$ ;  $\text{ML}_n = \text{Pd}(\text{PPh}_3)_2, \text{Pt}(\text{PPh}_3)_2$ ] are obtained from  $\text{Fe}_2(\mu\text{-E}_2)(\text{CO})_6$  and  $\text{M}(\eta\text{-C}_2\text{H}_4)(\text{PPh}_3)_2$  [106]; similar reactions with  $\text{Co}(\text{CO})_2(\eta\text{-C}_5\text{H}_5)$ ,  $\text{Ni}(\text{CO})_2\text{-}(\text{dppe})$  or  $\text{Pt}(\text{PPh}_3)_4$  afford [117;  $\text{E} = \text{Se}$ ,  $\text{ML}_n = \text{Co}(\eta\text{-C}_5\text{H}_5)$ ,  $\text{Ni}(\text{dppe})$ ,  $\text{Pt}(\text{PPh}_3)_2$ ] [103]. These reactions proceed by insertion of the  $\text{ML}_n$  moiety into the E-E bond, but metal-metal bond formation does not occur.

Cluster complexes with related structures have been prepared using other routes. Thus, low yields (ca 10%) of (118) were obtained from  $\text{Fe}_2(\text{CO})_9$  and  $\text{Mn}(\text{CO})_2(\text{PCL}_2\text{Ph})(\eta\text{-C}_5\text{H}_5)$ ; an improved synthesis, giving (118) in 48% yield, is from the reaction between  $\text{Fe}_3(\text{CO})_{12}$  and  $\text{Mn}(\text{CO})_2(\text{PH}_2\text{Ph})(\eta\text{-C}_5\text{H}_5)$  [107].

Acidification of a mixture of sodium sulphide,  $[\text{HFe}(\text{CO})_4]^-$  and  $[\text{Co}(\text{CO})_4]^-$  affords  $\text{HFe}_2\text{Co}(\mu_3\text{-S})(\text{CO})_9$  (119) in low yield; an improved synthesis is by the redox condensation of  $\text{Co}_2(\text{CO})_8$  and  $[\text{Fe}_3(\mu_3\text{-S})(\text{CO})_9]^{2-}$  in  $\text{CH}_2\text{Cl}_2$ , followed by acidification (15-30%). However, treatment of

mixtures of  $\text{Fe}(\text{CO})_5$  and  $\text{Co}_2(\text{CO})_8$  with  $\text{Na}_2\text{S}$  or  $\text{NaSEt}$  in ethanol under CO (100 atm,  $150^\circ\text{C}$ ) gives violet (119) in 50-75% yield. The complex readily ionises in polar solvents, e.g. pyridine, and the anion can be isolated with suitable cations, such as  $[\text{NEt}_4]^+$ . If the anion is acidified in the presence of nitrite, red-brown chiral  $\text{Fe}_2\text{Co}(\mu_3\text{-S})(\text{CO})_8(\text{NO})$  (120) is formed in 70% yield [108].

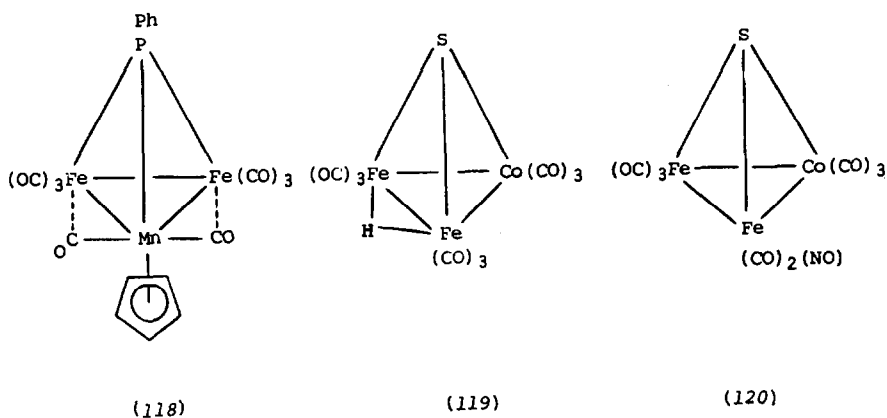

One of the more interesting developments was the synthesis of the first optically active metal clusters. Chiral clusters containing an  $\text{MoFeCoS}$  core (121) had first been reported in 1978 [109]. Preparation of a derivative containing (*R*)- $\text{PMePrPh}$  allowed separation of the diastereomers (122a and b) by crystallisation, which were separately converted back to the enantiomers (121a) and (121b) under CO in the presence of MeI.

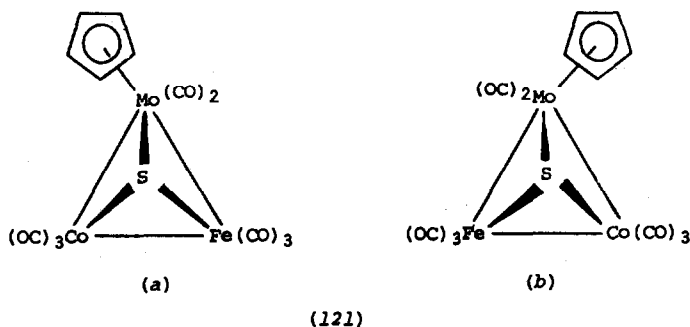

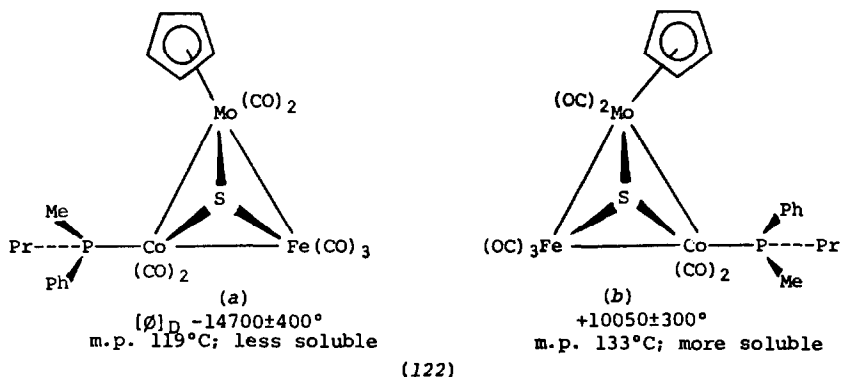

The absolute configurations of the enantiomers of (121) were established by an X-ray study of (122b) [110].

The black arsinidene cluster  $\text{FeCo}_2(\mu_3\text{-AsMe})(\text{CO})_9$  (123) has been obtained from  $\text{Fe}(\text{CO})_4(\text{AsH}_2\text{Me})$  and either  $\text{Co}_2(\text{CO})_8$  or  $\text{Co}(\text{CO})_3(\eta\text{-C}_5\text{H}_5)$  (10%) [111].

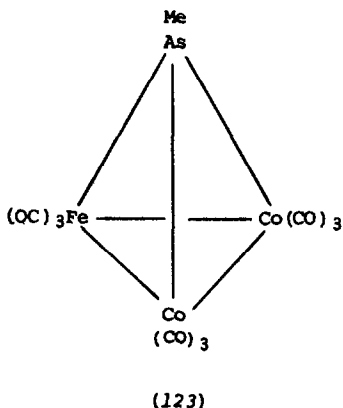

Related compounds (124; R = Me or Ph) containing  $\mu_3$ -germylidyne groups have been obtained by the metal exchange route starting with  $\text{Co}_3(\mu_3\text{-GeR})(\text{CO})_9$  and  $[\text{Mo}(\text{CO})_3(\eta\text{-C}_5\text{H}_5)]_2$ . The silicon analogues (126; M = Mo or W) were prepared in low yield (ca 14%) by a cluster assembly sequence of reactions from  $\text{Co}_2(\text{CO})_8$  and  $\text{M}(\text{SiH}_2\text{Me})(\text{CO})_3(\eta\text{-C}_5\text{H}_5)$ ; the first formed  $\text{MSiCo}_2$  complexes (125) condense to the heterometal clusters on heating in benzene (24 h, reflux) [112].



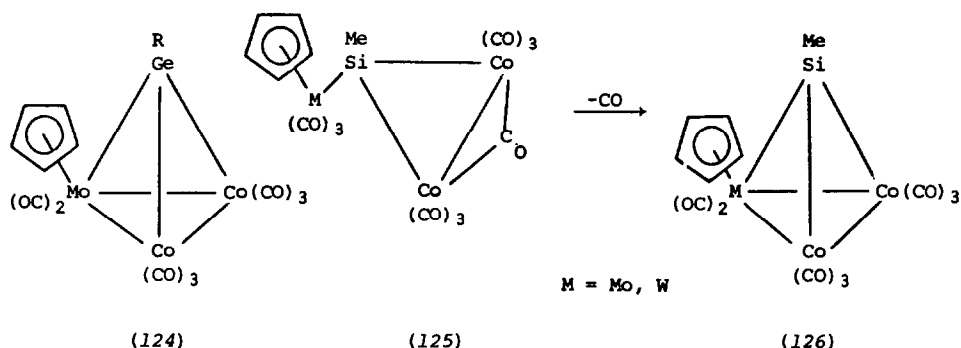

Heterometallic clusters from  $\text{Cr}_2(\mu\text{-S})(\mu\text{-S}^t\text{Bu})_2(\eta\text{-C}_5\text{H}_5)_2$  The chemistry of  $\text{Cr}_2(\mu\text{-S})(\mu\text{-S}^t\text{Bu})_2(\eta\text{-C}_5\text{H}_5)_2$  (Scheme 10, 127) has attracted the attention of Russian workers [113]. This complex is the first binuclear organometallic complex to be described wherein the presence of the Cr-Cr bond (2.689 Å) does not result in diamagnetism. Instead, (127) is antiferromagnetic, as is the methylated derivative  $[\text{Cr}_2(\mu\text{-SMe})(\mu\text{-S}^t\text{Bu})_2(\eta\text{-C}_5\text{H}_5)]^+$  [114]. Complex (127) has been used as a source of heterometallic derivatives by utilising the reactivity of the bridging sulphur atom. The nature of the products depends on the coordination number of the heterometal atom. Reactions with Group VI metal carbonyls in thf under UV irradiation rapidly result in the formation of the simple adducts (128) which are also antiferromagnetic [115]. With  $\text{Mn}_2(\text{CO})_{10}$ , a CO *cis* to the Mn-Mn bond is substituted in the product (129) [116]; the  $\text{Mn}(\text{CO})_2(\eta\text{-C}_5\text{H}_5)$  derivative (130) is similarly *S*-bonded [117].

Heterometallic clusters were obtained from the reactions between (127) and  $\text{M}(\text{CO})_4(\eta\text{-C}_5\text{H}_5)$  ( $\text{M} = \text{V}, \text{Nb}$ ) [117]. Complete loss of CO and  $\text{Bu}^t$  ligands occurs with formation of the black tetrahedral clusters  $\text{MCr}_3(\mu_3\text{-S})_4(\eta\text{-C}_5\text{H}_5)_4$  (131); the  $\text{Cr}_4$  analogue was formed by heating (127) in xylene, or  $\text{Cr}(\eta\text{-C}_5\text{H}_5)_2$  and sulphur in toluene. With  $\text{Fe}(\text{CO})_5$  in a photochemical reaction, one  $\text{Bu}^t$  and two CO groups are eliminated to give black  $\text{Cr}_2\text{Fe}(\mu_3\text{-S})_2(\mu\text{-S}^t\text{Bu})(\text{CO})_3(\eta\text{-C}_5\text{H}_5)$  (132). The Fe atom is bonded to only one Cr, the other non-bonding vector [3.110 Å] being bridged by the  $\mu_3\text{-S}$

SCHEME 10. Syntheses of some heteronuclear metal clusters from  $\text{Cr}_2(\mu\text{-S})(\mu\text{-SBu}^t)_2(\eta\text{-C}_5\text{H}_5)_2$   
 Reagents: i, MeI; ii,  $\text{M}(\text{CO})\text{L}_n$ ;  $\text{ML}_n = \text{Cr}(\text{CO})_5$ ,  $\text{Mo}(\text{CO})_5$ ,  $\text{W}(\text{CO})_5$ ,  $\text{Mn}_2(\text{CO})_9$ ,  $\text{Mn}(\text{CO})_2(\eta\text{-C}_5\text{H}_5)$ ;  
 iii,  $\text{M}(\text{CO})_4(\eta\text{-C}_5\text{H}_5)$  ( $\text{M} = \text{V}, \text{Nb}$ ); iv,  $\text{Fe}(\text{CO})_5$ ; v,  $\text{Co}_2(\text{CO})_8$ ; vi, heat with  $\text{C}_2\text{Ph}_2$ .

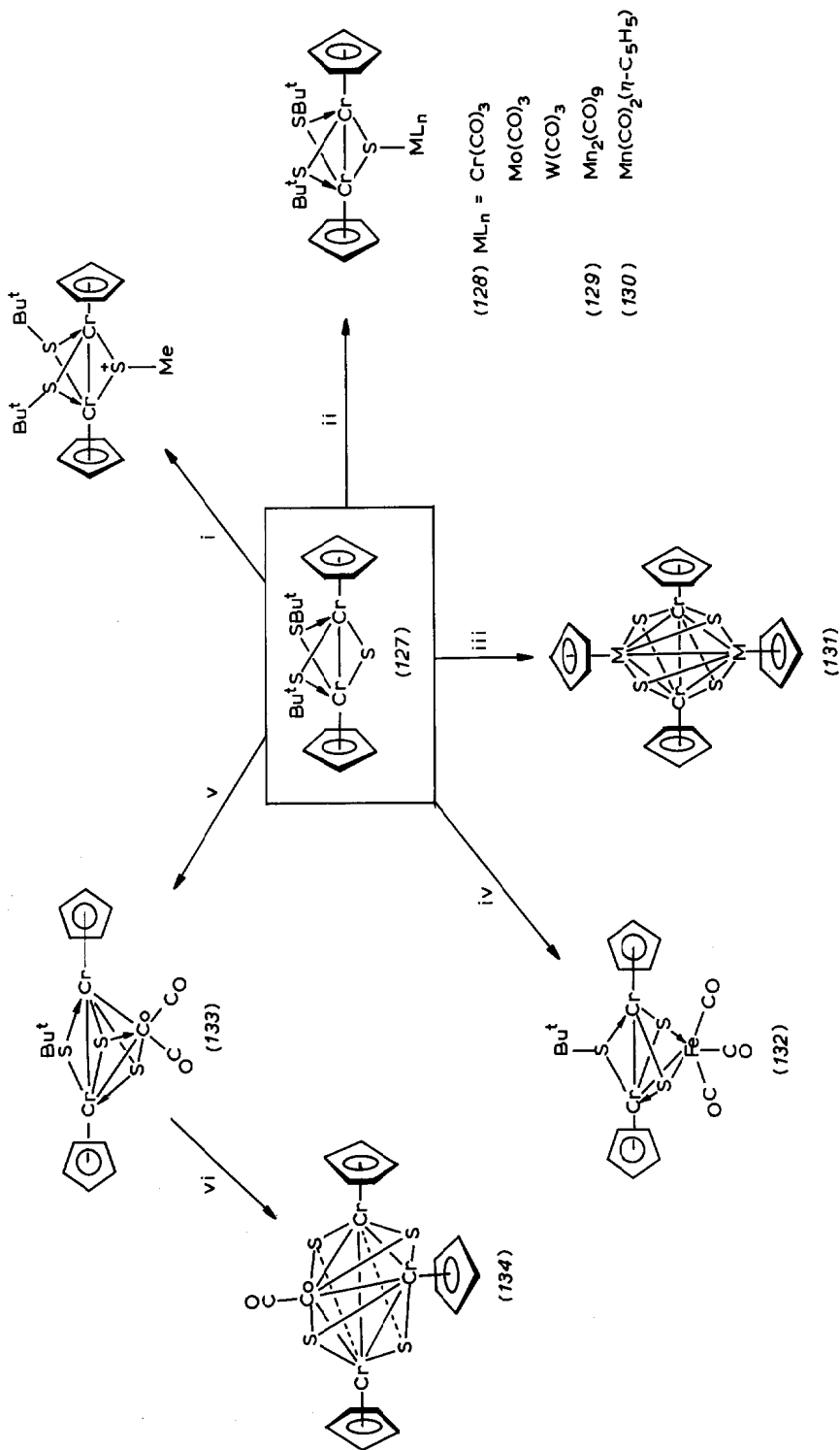

ligands [118]. Complex (127) reacts with  $\text{Co}_2(\text{CO})_8$  in thf to give dark-brown  $\text{Cr}_2\text{Co}(\mu_3\text{-S})_2(\mu\text{-SBU}^t)(\text{CO})_2(\eta\text{-C}_5\text{H}_5)$  (133) in which all the metal-metal interactions are bonding [116]. On heating (133) with diphenylacetylene, it is transformed into the tetranuclear complex (134), in which each face of the tetrahedral  $\text{Cr}_3\text{Co}$  core is capped by S [119].

A major interest of this work has been in the use of (127) as an antiferromagnetic ligand in complexes (128)-(130), and as a source of the antiferromagnetic metal sequence complex (132) and cluster (133), the latter being the first such example described. In all of these, the exchange parameters have been determined for each direct metal-metal interaction, and differences can be correlated with changes in geometry. Cluster (131) is paramagnetic, while (134) is diamagnetic.

Complexes with  $\mu\text{-Cl}$  or  $\mu\text{-OH}$  ligands      Dehalogenation of several metal halides with iron carbonyls has often been used as a route to mixed-metal derivatives containing iron. The reaction between  $\text{Fe}_2(\text{CO})_9$  and  $\text{RuCl}_2(\text{PR}_3)(\eta^6\text{-arene})$  is another example of this type of reaction, and affords the  $\text{FeRu}_2$  complexes (135) as major products (20-40%), in which the  $\mu\text{-Cl}$  ligands bridge the two ruthenium atoms [120]. Their separation [ $3.185(2)\text{\AA}$  in the  $\text{P}(\text{C}\equiv\text{C}\text{Bu}^t)\text{Ph}_2$  complex] is too long for a formal Ru-Ru bond, and indeed one is not required for the usual electron counting. Yields of (135;  $\text{L} = \text{PPh}_3$ ) decrease in the order arene =  $\text{C}_6\text{H}_6 > p\text{-cymene} > \text{C}_6\text{Me}_6$ , but those of (135;  $\text{L} = \text{P}(\text{OMe})_3$ ) are similar when  $\text{RuX}_2[\text{P}(\text{OMe})_3](\eta\text{-C}_6\text{H}_6)$  ( $\text{X} = \text{Cl}$  or  $\text{I}$ ) are used as precursors. As is commonly observed, the reactions are not simple,

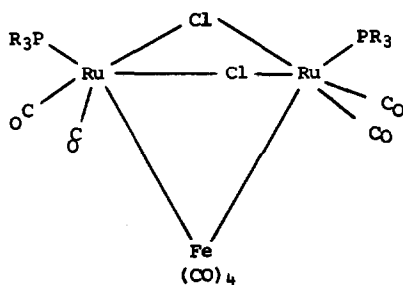

$\text{PR}_3 = \text{PMe}_3, \text{PMe}_2\text{Ph},$   
 $\text{PPh}_3, \text{P}(\text{OMe})_3,$   
 $\text{Ph}_2\text{P}(\text{C}\equiv\text{C}\text{Bu}^t)$

and by-products include  $\text{FeRu}_2(\text{CO})_{10}(\text{PR}_3)_2$ ,  $\text{Fe}_2\text{Ru}(\text{CO})_{11}(\text{PR}_3)$  and  $\text{Ru}_3(\text{CO})_{10}(\text{PR}_3)_2$ .

The  $\mu\text{-Cl}$  complexes (135) react with bases in acetone to give orange (136;  $\text{L} = \text{PMe}_3$  or  $\text{PPh}_3$ ), containing  $\mu\text{-OH}$  ligands; in isopropanol, similar reactions with bases afford red (137), in which  $\mu\text{-H}$  groups are present [121]. The  $\text{Fe}(\text{CO})_4$  group in (135;  $\text{L} = \text{PPh}_3$ ) is removed on reaction with  $\text{KI}$  in  $(\text{CH}_2\text{OMe})_2$  to give  $[\text{Ru}(\mu\text{-I})(\text{CO})_2(\text{PPh}_3)]_2$ .

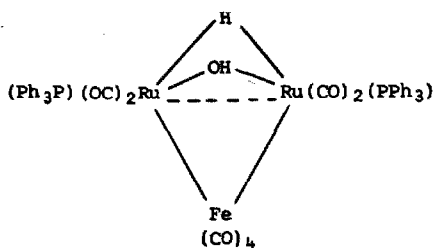
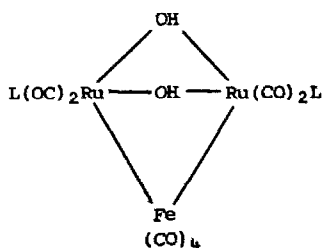

The first examples of complexes containing anionic metal carbonyl units as bridges between palladium were obtained from reactions between  $[\text{Mo}(\text{CO})_3(\eta\text{-C}_5\text{H}_5)]^-$ ,  $[\text{Fe}(\text{CO})_3(\text{NO})]^-$  or  $[\text{Co}(\text{CO})_4]^-$  and  $[\text{Pd}(\mu\text{-Cl})(\text{C}_6\text{H}_4\text{-CH}_2\text{NMe}_2)]_2$  [122]. In these compounds, one of the  $\mu\text{-Cl}$  ligands in the latter complex as replaced by  $\text{Mo}(\text{CO})_3(\eta\text{-C}_5\text{H}_5)$ ,  $\text{Fe}(\text{CO})_3(\text{NO})$  or  $\text{Co}(\text{CO})_4$  groups, respectively (138). The metal atoms form open  $\text{MPd}_2$  triangles, which for  $\text{M} = \text{Mo}$  is triply-bridged by a CO ligand (138a); the Pd-M bonds are also bridged by CO. The Co complex is formed as two isomers, differing in the orientation ('cis' and 'trans') of the cyclometallated ligand. In solution, the compounds are fluxional by some process which generates a plane of symmetry (not found in the solid) containing the cyclometallated ligands and the metal atoms.

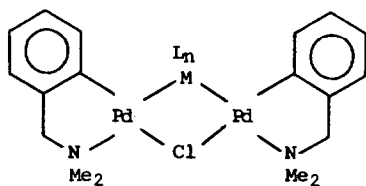

(138)

$ML_n = Mo(CO)_3(n-C_5H_5), Fe(CO)_3(NO),$   
 $Co(CO)_4$

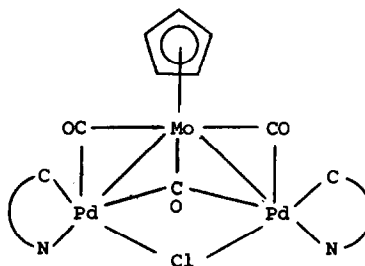

(138a)

## 8. SULPHUR-BRIDGED CLUSTERS OF BIOLOGICAL INTEREST AND RELATED THIO-METALLATE COMPLEXES

**MFe<sub>3</sub>S<sub>4</sub> clusters** The immense amount of interest in, and generated by, the cubane-like MoFe<sub>3</sub>S<sub>4</sub> clusters, their dimers and tungsten analogues, as a result of these compounds representing the closest synthetic analogues for the molybdenum centre of nitrogenase, is reflected in the large number of publications dealing with this subject which have appeared during the two years under review. In addition to the biological implications, this work has resulted in the development of new synthetic techniques, and the structural characterisation of so many of these complexes has allowed a clearer understanding of the metal-metal and metal-sulphur interactions therein. However, the relevance of these studies to organometallic chemistry in the context of this article lies only in the heterometallic interactions, so that a comprehensive survey will not be given. Instead, the major synthetic and structural achievements are considered only within these limitations.

**Reviews** The proceedings of an international symposium on *Molybdenum Chemistry of Biological Significance*, held in Kyoto in 1979 include several articles on the functions and active sites of the Fe/Mo protein in nitrogenase, with a review of XAFS studies on model systems [123]. A complete

section of the proceedings is devoted to the Fe/Mo cofactor and MoFeS cubane clusters. Similarly, the proceeding of the *Fourth International Conference on Nitrogen Fixation*, held in Canberra in 1980, also contain several review articles on subjects germane to this area [124]. The relevant citations are listed in Table 2.

Coucouvanis has described his work on Fe-M-S complexes (M = Mo or W) derived from thiometallate anions, and their possible relevance as analogues for structural features of the molybdenum site of nitrogenase. This article also contains references to earlier studies [125].

**Papers** Most publications have described the syntheses and/or structures of new complexes containing either monomeric or dimeric  $\text{MoFe}_3\text{S}_4$  cores, and differing in the terminal ligands; included in these are electrochemical, magnetic, Mössbauer and NMR studies, together with reports describing substitution reactions, and the preparation of reduced species; systems containing the latter can reduce acetylene to ethylene catalytically, and evolve hydrogen. Detailed citations are summarised in Table 3.

**Transition metal thiometallates and related complexes** Several examples of mixed-metal thiometallate complexes have been prepared, including isomeric  $(\eta\text{-C}_5\text{H}_5)_2\text{Mo}(\mu\text{-S})_2\text{WS}_2$  and  $(\eta\text{-C}_5\text{H}_5)_2\text{W}(\mu\text{-S})_2\text{MoS}_2$ ; the dimeric oxo analogue  $[(\eta\text{-C}_5\text{H}_5\text{Me})_2\text{Mo}(\mu\text{-O})_2\text{WO}_2]_2$  was also described [126].

In  $[\text{S}_2\text{WS}_2\text{CoS}_2\text{WS}_2]^{2-}$ , spectroscopic and electrochemical data support an Extended Huckel MO study which indicates the MO's are delocalised, with strong metal-ligand interactions. Two 1e reductions result in a formally  $\text{Co}^0$  tetranion, stabilised by electron delocalisation  $\text{Co} \rightarrow \text{WS}_4$  [127].

Multinuclear complexes containing  $\text{MoS}_4^{2-}$  and  $\text{MoOS}_3^{2-}$  ligands have been obtained with Group IB metals, including those with cubane-type structures (139) and (140) and the extended trinuclear system (141) (see also Part A) [128].

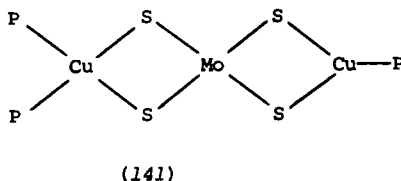
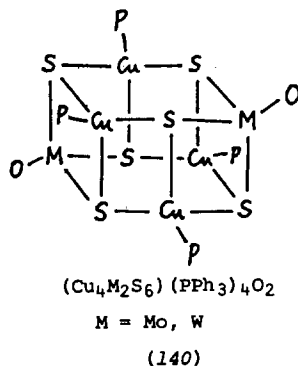
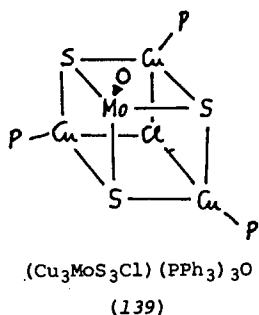

P = PPh<sub>3</sub>

Red (Cu<sub>3</sub>MoS<sub>3</sub>Cl)(PPh<sub>3</sub>)<sub>3</sub>S (139) can be obtained from (NH<sub>4</sub>)<sub>2</sub>MoS<sub>4</sub>, CuCl<sub>2</sub> and PPh<sub>3</sub> in a water-CH<sub>2</sub>Cl<sub>2</sub> system [129]. The complex has the pseudo-cubane structure and may be related to Cu-Mo-S interactions in biological systems. The reaction between Cs<sub>2</sub>[WOS<sub>3</sub>], CuCl<sub>2</sub> and PPh<sub>3</sub> over 5-6 days in a two phase water-CH<sub>2</sub>Cl<sub>2</sub>-acetone-pentane system affords a 4:6 mixture of yellow-orange [Cu<sub>3</sub>WS<sub>3</sub>Cl](PPh<sub>3</sub>)<sub>3</sub>O and red [Cu<sub>4</sub>W<sub>2</sub>S<sub>6</sub>](PPh<sub>3</sub>)<sub>4</sub>O (140), which can be separated mechanically [130]. The latter contains a cage formed by fusion of two SCu<sub>2</sub>S<sub>2</sub>W rings, and the analogous compounds of Ag<sup>+</sup> with MoOS<sub>3</sub><sup>2-</sup> and WOS<sub>3</sub><sup>2-</sup> are probably similar [131].

## 9. OTHER COMPLEXES CONTAINING HETERONUCLEAR CLUSTERS

**Metallacarboranes with heterometal bonds** Two examples of cluster compounds containing boron, carbon and two different metal atoms have been discussed in the period under review. Dark green 1,2,4,5-(η-C<sub>5</sub>H<sub>5</sub>)<sub>2</sub>-CoFe(H)Me<sub>2</sub>C<sub>2</sub>B<sub>3</sub>H<sub>3</sub> (142) was isolated as one product from a reaction between CoCl<sub>2</sub>, C<sub>5</sub>H<sub>5</sub><sup>-</sup> and (2,3-Me<sub>2</sub>C<sub>2</sub>B<sub>4</sub>H<sub>4</sub>)<sub>2</sub>FeH<sub>2</sub> in ethanolic KOH [132]. The iron and cobalt atoms occupy apical and equatorial positions in a pentagonal bipyramidal skelton; the H atom probably caps the Fe-Co-B(3) face. The

TABLE 2 Papers from recent conferences concerned with Mo-Fe-S cubane clusters and related chemistry

Authors	Topic	Page
(a)	Molybdenum Chemistry of Biological Significance [123]	
G.D. Watt	Electrochemical and kinetic studies of nitrogenase: brief review and recent developments	3
C.E. McKenna, T. Nakajima, J.B. Jones, C. Huang, M.C. McKenna, H. Eran and A. Osumi	Active site probes of nitrogenase	39
B.K. Burgess, S. Wherland, E.I. Stiefel and W.E. Newton	HD Formation by nitrogenase: A probe for N <sub>2</sub> reduction intermediates	73
W.H. Orme-Johnson, N.R. Orme-Johnson, C. Touton, M. Emptage, M. Henzl, J. Rawlings, K. Jacobson, J.P. Smith, W.B. Mins, B.H. Huynh, E. Munck and G.S. Jacob	Spectroscopic and chemical evidence for the nature and role of metal centers in nitrogenase and nitrate reductase	85
T.D. Tullins, S.D. Conradson, J.M. Berg and K.O. Hodgson	Structural chemistry of molybdenum in metalloenzymes as elucidated by EXAFS	139
B.E. Smith	Studies on the iron-molybdenum cofactor from the nitrogenase Mo-Fe protein of <i>Klebsiella pneumoniae</i>	179
W.E. Newton, B.K. Burgess and E.I. Stiefel	Chemical properties of the Fe-Mo cofactor from nitrogenase	191



C.D. Garner, G. Christou, S.R. Acott, F.E. Mabbs, R.M. Miller, T.J. King, M.G.B. Drew, C.E. Johnson, J.D. Rush and G.W. Kenner	Synthesis and characterization of iron-molybdenum-sulfur clusters	203
B.A. Averill, H.C. Silvis, R.H. Tieckelmann and W.H. Orme-Johnson	Chemical and physical studies of polynuclear Mo-Fe-S and mono-nuclear Mo(III) complexes	217
S. Otsuka and M. Kamata	Molybdo-iron mixed cluster as a Fe-Mo cofactor model	229
(b) <i>Current Perspectives in Nitrogen Fixation</i> [124]		
W.E. Newton, J.W. McDonald, G.D. Friesen, B.K. Burgess, S.D. Conradson and K.O. Hodgson	Mo-Fe-S complexes and their relevance to the molybdenum site of nitrogenase	30
C.D. Garner, S.R. Acott, G. Christou, D. Collison, F.E. Mabbs and R.M. Miller	Studies of Mo-Fe-S clusters	40
A. Müller	Mo-S chemistry related to nitrogen fixation	44
B.K. Burgess, S.-S. Yang, C.-B. You, J.-G. Li, G.D. Friesen, W.-H. Pan, E.I. Stiefel, W.E. Newton, S.D. Conradson and K.O. Hodgson	Fe-Mo cofactor and its complementary protein from <i>Azotobacter vinelandii</i> UW45	71
W.H. Orme-Johnson, P. Lindahl, J. Meade, W. Warren, B.H. Huynh, M. Emptage, J. Rawlings, J. Smith, J. Roberts, B. Hoffmann and W.B. Mims	Nitrogenase: prosthetic groups and their reactivities	79

TABLE 3 Papers describing aspects of the chemistry of  $\text{MoFe}_3\text{S}_4$  cubane cluster complexes

Citation	Subject
(a) <i>Synthesis, properties and structure</i>	
W.H. Armstrong and R.H. Holm, <i>J. Am. Chem. Soc.</i> , 103 (1981) 6246	Synthesis and structure of a new type of Mo-Fe-S cluster (double cubane); evidence for magnetically uncoupled $S = 3/2$ $\text{MoFe}_3\text{S}_4$ subclusters
G. Christou, D. Collison, C.D. Garner, F.E. Mabbs and V. Petrouleas, <i>Inorg. Nucl. Chem. Lett.</i> , 17 (1981) 137	Spin-exchange interactions in the cubane-like cluster dimers $[\text{NET}_4]_3[\text{M}_2\text{Fe}_6\text{S}_8(\text{SPh})_6(\text{OMe})_3]$ (M = Mo, W)
G. Christou and C.D. Garner, <i>J. Chem. Soc., Dalton Trans.</i> , (1980) 2354	Synthesis and NMR of $\text{MFe}_3\text{S}_4$ (M = Mo or W) cubane-like cluster dimers
T.E. Wolff, J.M. Berg and R.H. Holm, <i>Inorg. Chem.</i> , 20 (1981) 174	Synthesis, structure and properties of $[\text{MoFe}_4\text{S}_4(\text{SET})_3(\text{C}_6\text{H}_4\text{O}_2)_3]^{3-}$ with a single cubane $\text{MoFe}_3\text{S}_4$ core
T.E. Wolff, J.M. Berg, P.P. Power, K.O. Hodgson and R.H. Holm, <i>Inorg. Chem.</i> , 19 (1980) 431	Structures of Fe-bridged double cubane cluster complexes with $\text{MFe}_3\text{S}_4$ cores: $[\text{Mo}_2\text{Fe}_7\text{S}_8(\text{SET})_{12}]^{3-}$ , $[\text{M}_2\text{Fe}_7\text{S}_8(\text{SCH}_2\text{Ph})_{12}]^{4-}$ (M = Mo, W)

- T.E. Wolff, P.P. Power, R.B. Frankel and R.H. Holm,  
*J. Am. Chem. Soc.*, 102 (1980) 4694
- (b) *Chemical reactions, electrochemistry*
- G. Christou and C.D. Garner, *J. Chem. Soc., Chem. Commun.*,  
(1980) 613
- G. Christou, C.D. Garner, R.M. Miller, C.E. Johnson and  
J.D. Rush, *J. Chem. Soc., Dalton Trans.*, (1980) 2363
- G. Christou, R.V. Hageman and R.H. Holm, *J. Am. Chem. Soc.*,  
102 (1980) 7600
- C.D. Garner and R.M. Miller, *J. Chem. Soc., Dalton Trans.*,  
(1981) 1664
- K. Tanaka, M. Tanaka and T. Tanaka, *Chem. Lett.*, (1981)  
895
- Synthesis, electronic and redox properties of double-cubane  
clusters containing  $\text{MoFe}_3\text{S}_4$  and  $\text{WFe}_3\text{S}_4$  cores
- Ligand substitution reactions of Fe-Mo-S cubane-like cluster  
dimers: selective halide incorporation
- Mössbauer and electrochemical studies on  $\text{MoFe}_3\text{S}_4$  and  $\text{WFe}_3\text{S}_4$   
cubane-like cluster dimers
- Hydrogen evolution from homogeneous reaction systems containing  
reduced Mo-Fe-S clusters
- Electrochemical behaviour of  $[\text{M}_2\text{Fe}_6\text{S}_8(\text{SR})_9]^{3-}$  (M = Mo or W) and  
the roles of Mo or W in nitrogenases
- Reduction of acetylene to ethylene catalysed by reduced species  
from  $[\text{Mo}_2\text{Fe}_6\text{S}_9(\text{SPh})_8]^{3-}$
-

metal-metal separation [2.557(1)Å] compares well with Co-Co distance in the related complex  $(\eta\text{-C}_5\text{H}_5)_2\text{Co}_2\text{Me}_2\text{C}_2\text{B}_3\text{H}_3$ .

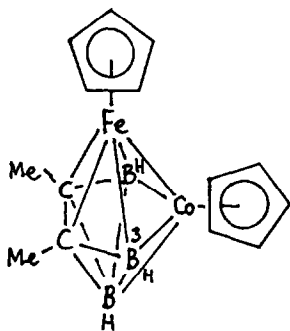

(142)

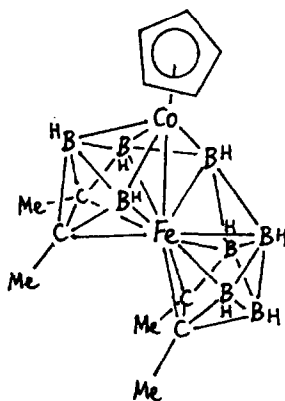

(143)

The unusual compound  $(\eta\text{-C}_5\text{H}_5)\text{CoFeMe}_4\text{C}_4\text{B}_8\text{H}_8$  (143) consists of two pentagonal bipyramids sharing an apical Fe atom, with a wedge B-H group. Several attempts to rationalise the bonding in this compound have been made; King and coworkers [133] have concluded that while the original proposal [134] contains several inconsistencies, the crystallographic data do not allow an unambiguous distinction between two alternative bonding models which they advance.

**Hetero-metal atom clusters** The Faraday Symposium on Diatomic Metals and Metallic Clusters, already referred to in Part A, contained a review of experimental results includes values for the atomisation energies,  $D_0^0$ , of  $\text{Au}_2\text{Eu}$ ,  $\text{Au}_2\text{Ho}$ ,  $\text{Au}_2\text{Lu}$  and  $\text{RhTi}_2$ , and a comparison with values calculated using the Pauling model (polar single bond).

**Structural studies** Table 4 summarises X-ray studies of nearly 100 complexes containing heteronuclear metallic clusters which were published during 1980-81, together with values of the hetero-metal separations. The shape of the hetero-transition metal core is also indicated, but readers are referred to the structural diagrams in the main text for details of bridging groups and other ligands present.

TABLE 4 Structural studies of heteronuclear metal clusters 1980-81

Core	Shape	Complex	M-M'	Separation (Å)	Reference
(a) Three-atom clusters					
CoCr <sub>2</sub>	A	CoCr <sub>2</sub> (μ <sub>3</sub> -S) <sub>2</sub> (μ-SBu <sup>t</sup> )(CO) <sub>2</sub> (η-C <sub>5</sub> H <sub>5</sub> ) <sub>2</sub>	(133) Co-Cr	2.579, 2.592 (1)	[119]
CoFeMo	A	CoFeMo(μ <sub>3</sub> -S)(CO) <sub>7</sub> (PMePrPh)	(122) Co-Fe Co-Mo Fe-Mo Co-Fe	2.568 (2) 2.750 (2) 2.793 (2) 2.623 (1)	[110]
CoFe <sub>2</sub>	B	CoFe <sub>2</sub> (μ-PMe <sub>2</sub> )(μ-SMe) <sub>2</sub> (CO) <sub>8</sub>	(108)		[97]
CoMoNi	A	CoMoNi(μ <sub>3</sub> -CMe)(CO) <sub>5</sub> (η-C <sub>5</sub> H <sub>5</sub> ) <sub>2</sub>	(79) Co-Mo Co-Ni Mo-Ni M-M'	2.651 (4) 2.336 (4) 2.557 (3) 2.358 (2) <sup>b</sup>	[63]
CoNi <sub>2</sub>	A	CoNi <sub>2</sub> (CO) <sub>2</sub> (η-C <sub>5</sub> H <sub>5</sub> ) <sub>3</sub>	(50)		[64]
CoNi <sub>2</sub>	A	CoNi <sub>2</sub> (CO) <sub>2</sub> (η-C <sub>5</sub> H <sub>5</sub> ) <sub>2</sub> (η-C <sub>5</sub> Me <sub>5</sub> )	(50)	2.3686, 2.3740 (24)	[64]
CoPd <sub>2</sub>	B	[μ-Co(CO) <sub>4</sub> ](μ-Cl)[Pd(C <sub>6</sub> H <sub>4</sub> CH <sub>2</sub> NMe <sub>2</sub> ) <sub>2</sub> ] <sub>2</sub>	(138)	2.595, 2.597 (1)	[122]
Co <sub>2</sub> Fe	A	Co <sub>2</sub> Fe(μ-PPh <sub>2</sub> ) <sub>2</sub> (CO) <sub>8</sub>	(107) Co-Fe	2.530, 2.615 (2) (mol. 1) <sup>c</sup> 2.552, 2.597 (2) (mol. 2)	[96]
Co <sub>2</sub> Fe	A	Co <sub>2</sub> Fe(CO) <sub>6</sub> (η-C <sub>5</sub> Me <sub>5</sub> ) <sub>2</sub>	(41)	2.560, 2.577 (2)	[56]
Co <sub>2</sub> Fe	A	Co <sub>2</sub> Fe(CO) <sub>4</sub> (η-C <sub>4</sub> H <sub>4</sub> )(η-C <sub>5</sub> Me <sub>5</sub> ) <sub>2</sub>	(40)	2.512 (av.)	[56]
Co <sub>2</sub> Mn	A	Co <sub>2</sub> Mn(CO) <sub>4</sub> (η-C <sub>5</sub> H <sub>4</sub> Me)(η-C <sub>5</sub> Me <sub>5</sub> ) <sub>2</sub>	(40)	2.561 (av.)	[56]
Co <sub>2</sub> Pt	A	Co <sub>2</sub> Pt(CO) <sub>8</sub> (PPh <sub>3</sub> )	(36)	2.519, 2.532 (1)	[45]

Cr <sub>2</sub> Fe	B	Cr <sub>2</sub> Fe (μ <sub>3</sub> -S) <sub>2</sub> (μ-SBu <sup>t</sup> ) (CO) <sub>3</sub> (η-C <sub>5</sub> H <sub>5</sub> ) <sub>2</sub>	(132)	Cr-Fe	2.726 (2)	[118]
FeNi <sub>2</sub>	A	FeNi <sub>2</sub> (μ <sub>3</sub> -C <sub>2</sub> Ph <sub>2</sub> ) (CO) <sub>3</sub> (η-C <sub>5</sub> H <sub>5</sub> ) <sub>2</sub>	(93)	Fe-Ni	2.381 (5), 2.388 (4)	[61]
FeNi <sub>2</sub>	A	FeNi <sub>2</sub> (μ <sub>3</sub> -S) (CO) <sub>3</sub> (η-C <sub>5</sub> H <sub>5</sub> ) <sub>2</sub>	(116)	Fe-Ni	2.419, 2.427 (4)	[105]
FePtW	A	FePtW [μ <sub>3</sub> -C(tol)] (CO) <sub>6</sub> (PEt <sub>3</sub> ) (η-C <sub>5</sub> H <sub>5</sub> )	(81)	Fe-Pt	2.542 (3)	[83]
				Fe-W	2.784 (3)	
				Pt-W	2.775 (1)	
FeRhW	A	FeRhW [μ <sub>3</sub> -C(tol)] (CO) <sub>6</sub> (η-C <sub>5</sub> H <sub>5</sub> ) (η <sup>5</sup> -C <sub>9</sub> H <sub>7</sub> )	(85)	Fe-Rh	2.583 (1)	[83]
				Fe-W	2.772 (1)	
				Rh-W	2.760 (1)	
FeRu <sub>2</sub>	B	FeRu <sub>2</sub> (μ-Cl) <sub>2</sub> (CO) <sub>8</sub> (Ph <sub>2</sub> PC <sub>2</sub> Bu <sup>t</sup> ) <sub>2</sub>	(135)	Fe-Ru	2.808, 2.809 (3)	[120]
FeW <sub>2</sub>	A	FeW <sub>2</sub> [μ <sub>3</sub> -C <sub>2</sub> (tol)] <sub>2</sub> (CO) <sub>6</sub> (η-C <sub>5</sub> H <sub>5</sub> ) <sub>2</sub>	(86)	Fe-W	2.731, 2.745 (1)	[81]
Fe <sub>2</sub> Ir	A	Fe <sub>2</sub> Ir (CO) <sub>9</sub> (η-C <sub>5</sub> Me <sub>5</sub> )	(44)	Fe-Ir	2.616, 2.698 (7)	[58]
Fe <sub>2</sub> Mn	B	Fe <sub>2</sub> Mn (μ <sub>3</sub> -S) [μ <sub>3</sub> -SMn (CO) <sub>5</sub> ] (CO) <sub>9</sub>	(111)	Fe-Mn	2.714 (3)	[100]
Fe <sub>2</sub> Ni	A	Fe <sub>2</sub> Ni (μ <sub>3</sub> -C <sub>2</sub> Bu <sup>t</sup> ) (CO) <sub>6</sub> (η-C <sub>5</sub> H <sub>5</sub> )	(91)	Fe-Ni	2.378, 2.564 (3)	[88]
Fe <sub>2</sub> Ni	A	[Fe <sub>2</sub> Ni (μ <sub>3</sub> -C <sub>2</sub> Ph <sub>2</sub> ) (CO) <sub>6</sub> (η-C <sub>5</sub> H <sub>5</sub> )] [Ni (PMe <sub>3</sub> ) <sub>2</sub> (η-C <sub>5</sub> H <sub>5</sub> )]	(95)	Fe-Ni	2.453, 2.474 (1)	[89]
Fe <sub>2</sub> Pt	A	Fe <sub>2</sub> Pt (CO) <sub>8</sub> (η <sup>4</sup> -C <sub>8</sub> H <sub>12</sub> )	(27)	Fe-Pt	2.553, 2.561 (3)	[43]
Fe <sub>2</sub> W	A	Fe <sub>2</sub> W [μ <sub>3</sub> -C(tol)] [μ-C <sub>2</sub> (SiMe <sub>3</sub> ) <sub>2</sub> ] (CO) <sub>7</sub> (η-C <sub>5</sub> H <sub>5</sub> )	(71)	Fe-W	2.648, 2.775 (2)	[82]
Mn <sub>2</sub> Pt	B	Mn <sub>2</sub> Pt (μ-PPPh <sub>2</sub> ) <sub>2</sub> (CO) <sub>9</sub>	(103)	Mn-Pt	2.741, 2.747 (1)	[94]
Mn <sub>2</sub> Pt	Z	HfMn <sub>2</sub> Pt (μ-PPPh <sub>2</sub> ) <sub>3</sub> (CO) <sub>8</sub>	(104)	Mn-Pt	2.847 (2), [3.618 (2)]	[94]
MoPd <sub>2</sub>	B	[μ-Mo (CO) <sub>3</sub> (η-C <sub>5</sub> H <sub>5</sub> )] (μ-Cl) [Pd (C <sub>6</sub> H <sub>4</sub> CH <sub>2</sub> NiMe <sub>2</sub> ) <sub>2</sub> ] <sub>2</sub>	(138a)	Mo-Pd	2.788, 2.832 (1)	[122]

NiRu <sub>2</sub>	A	NiRu <sub>2</sub> (μ <sub>3</sub> -C <sub>2</sub> Ph <sub>2</sub> )(μ <sub>3</sub> -CO)(CO) <sub>3</sub> (η-C <sub>5</sub> H <sub>5</sub> ) <sub>2</sub>	(96)	Ni-Ru	2.550(3), 2.553(2)	[90]
Ni <sub>2</sub> Ru	A	Ni <sub>2</sub> Ru(μ <sub>3</sub> -C <sub>2</sub> Ph <sub>2</sub> )(CO) <sub>3</sub> (η-C <sub>5</sub> H <sub>5</sub> ) <sub>2</sub>	(93)	Ni-Ru	2.493, 2.496(3)	[61]
OsPt <sub>2</sub>	A	OsPt <sub>2</sub> (μ <sub>3</sub> -C <sub>2</sub> Me <sub>2</sub> )(CO) <sub>5</sub> (PPh <sub>3</sub> ) <sub>2</sub>	(98)	Os-Pt	2.664, 2.669(2)	[50]
OsW <sub>2</sub>	A	OsW <sub>2</sub> [μ <sub>3</sub> -C <sub>2</sub> (tol) <sub>2</sub> ](CO) <sub>7</sub> (η-C <sub>5</sub> H <sub>5</sub> ) <sub>2</sub> (symmetrical isomer, 88a)		Os-W	2.863, 2.839(2)	[81, 86]
OsW <sub>2</sub>	A	OsW <sub>2</sub> [μ <sub>3</sub> -C <sub>2</sub> (tol) <sub>2</sub> ](CO) <sub>7</sub> (η-C <sub>5</sub> H <sub>5</sub> ) <sub>2</sub> (unsymmetrical isomer, 88b)		Os-W	2.876, 2.981(2)	[81, 86]
PtRh <sub>2</sub>	A	PtRh <sub>2</sub> (CO) <sub>3</sub> (PPh <sub>3</sub> )(η-C <sub>5</sub> Me <sub>5</sub> ) <sub>2</sub>	(52)	Pt-Rh	2.617, 2.683(1)	[65]
PtRh <sub>2</sub>	A	[HPtRh <sub>2</sub> (CO) <sub>3</sub> (PPh <sub>3</sub> )(η-C <sub>5</sub> Me <sub>5</sub> ) <sub>2</sub> ][BF <sub>4</sub> ]	(54)	Pt-Rh	2.705, 2.805(1)	[66]
Pt <sub>2</sub> W	A	Pt <sub>2</sub> W[μ-C(OMe)Ph](CO) <sub>6</sub> (PMeBu <sub>2</sub> <sup>t</sup> ) <sub>2</sub>	(67)	Pt-W	2.828, 2.832(2)	[78]
(b) Four-atom clusters						
Ag <sub>2</sub> Au <sub>2</sub>	F	{[(C <sub>4</sub> H <sub>8</sub> S)AgAu(C <sub>6</sub> F <sub>5</sub> ) <sub>2</sub> ] <sub>2</sub> ] <sub>n</sub>	(66)	Ag-Au	2.717, 2.726(2)	[77]
AuOs <sub>3</sub>	D	HAuOs <sub>3</sub> (CO) <sub>10</sub> (PPh <sub>3</sub> )	(61)	Au-Os	2.738(1), 2.772(2)	[73]
AuOs <sub>3</sub>	D	AuOs <sub>3</sub> (μ-SCN)(CO) <sub>10</sub> (PPh <sub>3</sub> )	(62)	Au-Os	2.755, 2.768(1)	[73]
Au <sub>3</sub> V	C	Au <sub>3</sub> V(CO) <sub>5</sub> (PPh <sub>3</sub> ) <sub>3</sub>	(59)	Au-V	2.709, 2.736, 2.756(1)	[71]
CoCr <sub>3</sub>	C	CoCr <sub>3</sub> (μ <sub>3</sub> -S) <sub>4</sub> (CO)(η-C <sub>5</sub> H <sub>5</sub> ) <sub>3</sub>	(134)	Co-Cr	2.649, 2.656, 2.666(4)	[119]
CoRu <sub>3</sub>	C	H <sub>3</sub> CoRu <sub>3</sub> (CO) <sub>12</sub>	(20a)	Co-Ru	2.672, 2.674, 2.678(2)	[40]
CoRu <sub>3</sub>	C	[ppn][CoRu <sub>3</sub> (CO) <sub>13</sub> ]	(19)	Co-Ru	2.611, 2.612, 2.631(1)	[38]
Co <sub>2</sub> Fe <sub>2</sub>	F	Co <sub>2</sub> Fe <sub>2</sub> (μ <sub>4</sub> -PPh) <sub>2</sub> (CO) <sub>11</sub>	(113)	Co-Fe	2.62(2)	[101]

Co <sub>2</sub> Fe <sub>2</sub>	F	Co <sub>2</sub> Fe <sub>2</sub> (μ <sub>4</sub> -S) <sub>2</sub> (CO) <sub>11</sub>	(112)	Co-Fe	2.58(3)	[101]
Co <sub>2</sub> Ru <sub>2</sub>	C	Co <sub>2</sub> Ru <sub>2</sub> (CO) <sub>13</sub>	(18)	Co-Ru	2.614, 2.660, 2.703, 2.731(3)	[36]
Co <sub>3</sub> Fe	C	HCo <sub>3</sub> Fe(CO) <sub>9</sub> (PMe <sub>2</sub> Ph) <sub>3</sub>	(16)	Co-Fe	2.546, 2.554, 2.592(3)	[31]
Co <sub>3</sub> Fe	D	Co <sub>3</sub> Fe(μ <sub>4</sub> -C=CH <sub>2</sub> )(CO) <sub>9</sub> (η-C <sub>5</sub> H <sub>5</sub> )	(99)	Co-Fe	2.499(2)	[85]
Cr <sub>2</sub> Fe <sub>2</sub>	D	Cr <sub>2</sub> Fe <sub>2</sub> (μ <sub>3</sub> -S) <sub>2</sub> (CO) <sub>8</sub> (η-C <sub>5</sub> H <sub>5</sub> ) <sub>2</sub>	(110)	Cr-Fe	2.762(3)	[99]
FeRh <sub>3</sub>	D	FeRh <sub>3</sub> (μ-PPPh <sub>2</sub> ) <sub>3</sub> (CO) <sub>8</sub>	(109)	Fe-Rh	2.77(1)	[98]
FeRu <sub>3</sub>	C	H <sub>2</sub> FeRu <sub>3</sub> (CO) <sub>12</sub> (PMe <sub>2</sub> Ph)	(10b)	Fe-Ru	2.692, 2.720, 2.721(1)	[24]
FeRu <sub>3</sub>	C	[ppn][HFeRu <sub>3</sub> (CO) <sub>13</sub> ]	(5)	Fe-Ru	2.682, 2.708, 2.758(2)	[19]
FeRu <sub>3</sub>	D	FeRu <sub>3</sub> (μ <sub>4</sub> -C <sub>2</sub> Ph <sub>2</sub> )(CO) <sub>12</sub>	(90a)	M <sup>3</sup> -Ru	2.681, 2.700(1) <sup>d</sup>	[87]
FeRu <sub>3</sub>	D	FeRu <sub>3</sub> (η <sub>4</sub> -C <sub>2</sub> Ph <sub>2</sub> )(CO) <sub>12</sub>	(90b)	M <sup>4</sup> -Ru	2.649, 2.681(1)	
FeRu <sub>3</sub>	D	FeRu <sub>3</sub> (η <sub>4</sub> -C <sub>2</sub> Ph <sub>2</sub> )(CO) <sub>12</sub>	(90b)	M <sup>1</sup> -Ru	2.688, 2.712(1) <sup>e</sup>	[87]
FeRu <sub>3</sub>	E	FeRu <sub>3</sub> (μ-PPPh <sub>2</sub> ) <sub>2</sub> (CO) <sub>13</sub>	(106)	M <sup>2</sup> -Ru	2.646, 2.680(1)	
Fe <sub>2</sub> Ni <sub>2</sub>	C	Fe <sub>2</sub> Ni <sub>2</sub> (CO) <sub>7</sub> (η-C <sub>5</sub> H <sub>5</sub> ) <sub>2</sub>	(46)	M <sup>1</sup> -M <sup>2</sup>	2.780(1)	
Fe <sub>2</sub> Ni <sub>2</sub>	F	Fe <sub>2</sub> Ni <sub>2</sub> (μ <sub>4</sub> -C <sub>2</sub> Et <sub>2</sub> )(CO) <sub>6</sub> (η-C <sub>5</sub> H <sub>5</sub> ) <sub>2</sub>	(94)	Fe-Ru	2.861, 2.868(1)	[95]
Fe <sub>2</sub> Pt <sub>2</sub>	C	H <sub>2</sub> Fe <sub>2</sub> Pt <sub>2</sub> (CO) <sub>8</sub> (PPh <sub>3</sub> ) <sub>2</sub>	(25)	Fe-Ni	2.408, 2.411, 2.432, 2.438(2)	[60]
Fe <sub>2</sub> Pt <sub>2</sub>	C	[ppn][HFe <sub>2</sub> Pt <sub>2</sub> (CO) <sub>8</sub> (PPh <sub>3</sub> ) <sub>2</sub> ]	(24)	Fe-Ni	2.414, 2.417, 2.422, 2.426(3)	[60]
Fe <sub>2</sub> Ru <sub>2</sub>	C	[ppn][HFe <sub>2</sub> Ru <sub>2</sub> (CO) <sub>13</sub> ]	(6)	Fe-Pt	2.604, 2.631, 2.694, 2.696(3)	[43]
Ir <sub>2</sub> W <sub>2</sub>	C	Ir <sub>2</sub> W <sub>2</sub> (CO) <sub>10</sub> (η-C <sub>5</sub> H <sub>5</sub> ) <sub>2</sub>	(43)	Fe-Pt	2.555, 2.562, 2.626, 2.756(2)	[43]
				Fe-Ru	2.572, 2.675, 2.676, 2.677(1)	[19]
				Ir-W	2.796, 2.833, 2.847, 2.863(1)	[57]



Ir <sub>3</sub> W	C	Ir <sub>3</sub> W(CO) <sub>11</sub> (η-C <sub>5</sub> H <sub>5</sub> )	(42)	Ir-W	2.792, 2.815, 2.865(1)	[57, 136]
Mn <sub>2</sub> Pt <sub>2</sub>	H	Mn <sub>2</sub> Pt <sub>2</sub> (μ-PPh <sub>2</sub> ) <sub>4</sub> (CO) <sub>8</sub>	(105)	Mn-Pt	2.710, 2.717(2)	[94]
NiOs <sub>3</sub>	C	H <sub>2</sub> NiOs <sub>3</sub> (CO) <sub>10</sub> (PPh <sub>3</sub> ) <sub>2</sub>	(32)	Ni-Os	2.605, 2.668, 2.733(1)	[42]
NiRu <sub>3</sub>	D	NiRu <sub>3</sub> (μ <sub>4</sub> -C-CHBu <sup>t</sup> )(CO) <sub>9</sub> (η-C <sub>5</sub> H <sub>5</sub> )	(100)	Ni-Ru	2.555, 2.572(3)	[91]
NiRu <sub>3</sub>	D	NiRu <sub>3</sub> (μ <sub>4</sub> -C-MeCHCET)(CO) <sub>8</sub> (η-C <sub>5</sub> H <sub>5</sub> )	(101)	Ni-Ru	2.595(5), 2.611(3)	[92]
Os <sub>2</sub> Pt <sub>2</sub>	D	H <sub>2</sub> Os <sub>2</sub> Pt <sub>2</sub> (CO) <sub>8</sub> (PPh <sub>3</sub> ) <sub>2</sub>	(35)	Os-Pt	2.7089, 2.8628(7)	[52]
Os <sub>3</sub> Pt	C	H <sub>2</sub> Os <sub>3</sub> Pt(CO) <sub>10</sub> (PCy <sub>3</sub> )	(33)	Os-Pt	2.791, 2.832, 2.863(1)	[49]
Os <sub>3</sub> Pt	D	H <sub>2</sub> Os <sub>3</sub> Pt(CO) <sub>10</sub> (PPh <sub>3</sub> ) <sub>2</sub>	(34)	Os-Pt	2.717(1), 2.848(2), [3.530(2)]	[50]
Os <sub>3</sub> Pt	C	H <sub>2</sub> Os <sub>3</sub> Pt(μ-CH <sub>2</sub> )(CO) <sub>10</sub> (PCy <sub>3</sub> ) (symmetrical isomer, 69a)		Os-Pt	2.730, 2.814, 2.826(1)	[80]
Os <sub>3</sub> Pt	C	H <sub>2</sub> Os <sub>3</sub> Pt(μ-CH <sub>2</sub> )(CO) <sub>10</sub> (PCy <sub>3</sub> ) (unsymmetrical isomer, 69b)		Os-Pt	2.777, 2.854, 2.867(2)	[80]
Os <sub>3</sub> Re	G	HOs <sub>3</sub> Re(CO) <sub>15</sub> (NCMe)	(3)	Os-Re	2.959(1)	[12]
Os <sub>3</sub> Re	C	H <sub>5</sub> Os <sub>3</sub> Re(CO) <sub>12</sub>	(4)	Os-Re	2.989(4), 3.017(3)	[12]
Os <sub>3</sub> Rh	D	H <sub>2</sub> Os <sub>3</sub> Rh(CO) <sub>10</sub> (acac)	(22)	Os-Rh	2.690, 2.743(2), [3.292(2)]	[42]
Os <sub>3</sub> W	C	Os <sub>3</sub> W[μ <sub>3</sub> -C(tol)](CO) <sub>11</sub> (η-C <sub>5</sub> H <sub>5</sub> )	(72)	Os-W	2.874, 2.867, 2.915(1)	[81]
Os <sub>3</sub> W	E	Os <sub>3</sub> W[μ <sub>3</sub> -COCH <sub>2</sub> (tol)](CO) <sub>11</sub> (η-C <sub>5</sub> H <sub>5</sub> )	(89)	Os-W	2.741, 2.914(1)	[86]
(c) Five-atom clusters						
AuCo <sub>3</sub> Fe	I	AuCo <sub>3</sub> Fe(CO) <sub>12</sub> (PPh <sub>3</sub> )	(60)	Au-Co	2.714(7)	[70]
				Co-Fe	2.56(8)	

Fe <sub>4</sub> Pd	K	[tmba] <sub>2</sub> [Fe <sub>4</sub> Pd(CO) <sub>16</sub> ]	(28)	Fe-Pd	2.599(av.)	[46]
Fe <sub>4</sub> Pt	K	[tmba] <sub>2</sub> [Fe <sub>4</sub> Pt(CO) <sub>16</sub> ]	(28)	Fe-Pt	2.601(av.)	[46]
Fe <sub>4</sub> Rh	J	[NEt <sub>4</sub> ][Fe <sub>4</sub> Rh(μ <sub>5</sub> -C)(CO) <sub>14</sub> ]	(57)	Fe-M	2.633(av.) <sup>f</sup>	[67]
				M-M	2.779(2)	
Ir <sub>4</sub> Ru	I	[ppn][Ir <sub>4</sub> Ru(CO) <sub>15</sub> ]	(21)	Ir-Ru	2.957,3.034,3.046(5)	[41]
PtRh <sub>4</sub>	K	PtRh <sub>4</sub> (CO) <sub>4</sub> (η-C <sub>5</sub> H <sub>5</sub> ) <sub>4</sub>	(55)	Pt-Rh	2.618(2) (mean)	[66]
(d) Six-atom clusters						
Fe <sub>3</sub> Pt <sub>3</sub>	N	[tmba][Fe <sub>3</sub> Pt <sub>3</sub> (CO) <sub>15</sub> ]	(30)	Fe-Pt	2.587(av.)	[47]
Fe <sub>3</sub> Pt <sub>3</sub>	N	[NBu <sub>4</sub> ] <sub>2</sub> [Fe <sub>3</sub> Pt <sub>3</sub> (CO) <sub>15</sub> ]	(30)	Fe-Pt	2.656(av.)	[47]
Fe <sub>5</sub> Mo	L	[NEt <sub>4</sub> ] <sub>2</sub> [Fe <sub>5</sub> Mo(μ <sub>6</sub> -C)(CO) <sub>17</sub> ]	(56)	Fe-Mo	2.915(av.)	[67]
Ni <sub>3</sub> Os <sub>3</sub>	M	Ni <sub>3</sub> Os <sub>3</sub> (CO) <sub>9</sub> (η-C <sub>5</sub> H <sub>5</sub> ) <sub>3</sub>	(48)	Ni-Os	2.61(av.)	[62]
(e) Seven-atom clusters						
AuOs <sub>6</sub>	O	[ppn][H <sub>2</sub> AuOs <sub>6</sub> (CO) <sub>20</sub> ]	(63)	Au-Os	2.802,2.806(1) (mol.1) <sup>c</sup> 2.809,2.814(1) (mol.2)	[74]
NiRh <sub>6</sub>	P	[NBu <sub>4</sub> ] <sub>2</sub> [NiRh <sub>6</sub> (CO) <sub>16</sub> ]	(39)	Ni-Rh	2.638,2.643,2.648(7)	[55]
(f) Eight-atom clusters						
Au <sub>6</sub> Co <sub>2</sub>	Z	Au <sub>6</sub> Co <sub>2</sub> (CO) <sub>8</sub> (PPh <sub>3</sub> ) <sub>4</sub>	(64)	Au-Co	2.46	[75]

$\text{Cu}_2\text{Rh}_6$	Q	$\text{Cu}_2\text{Rh}_6(\mu_6\text{-C})(\text{CO})_{15}(\text{NCMe})_2$	(58)	Cu-Rh	2.658, 2.659, 2.662 (1)	[69]
<b>(g) Ten-atom cluster</b>						
$\text{Fe}_6\text{Pt}_6$	Z	$[\text{tmba}]_2[\text{Fe}_4\text{Pt}_6(\text{CO})_{22}]$	(31)	Fe-Pt	2.540, 2.597 (av.)	[47]
<b>(h) Twelve-atom cluster</b>						
$\text{Fe}_6\text{Pd}_6$	R	$[\text{tmba}]_3[\text{HFe}_6\text{Pd}_6(\text{CO})_{24}]$	(29)	Fe-Pd	2.609, 2.698 (av.)	[46]

## Footnotes

<sup>a</sup> The shape of the transition metal core is indicated by the following:

A Triangle	H Bent four-atom sequence	N Edge-fused triangles
B Bent three-atom sequence	I Trigonal bipyramid	O Apically-joined butterflies
C Tetrahedron	J Square pyramid	P Capped octahedron
D Butterfly	K Bow-tie	Q Biccapped trigonal prism
E Triangulated rhombus	L Octahedron	R $\text{Pd}_6$ octahedron, 6 lateral faces capped by Fe
F Open rhombus	M Capped trigonal bipyramid	Z See diagram in text
G Metallated triangle		

<sup>b</sup> Disordered; Co, Ni atoms not distinguished; <sup>c</sup> Two independent molecules;

<sup>d</sup> Disordered;  $\text{M}^3 = 37\text{Fe}/67\text{Ru}$ ,  $\text{M}^4 = 63\text{Fe}/37\text{Ru}$ ; <sup>e</sup> Disordered;  $\text{M}^1 = 27\text{Fe}/73\text{Ru}$ ,

$\text{M}^2 = 73\text{Fe}/27\text{Ru}$ ; <sup>f</sup> Disordered;  $\text{M} = 50\text{Fe}/50\text{Rh}$ .

## References

1. W.L. Gladfelter and G.L. Geoffroy, *Adv.Organomet.Chem.*, 18 (1980) 207.
2. G.L. Geoffroy and D.A. Roberts, in *Comprehensive Organometallic Chemistry*, G. Wilkinson, F.G.A. Stone and E.W. Abel, eds., Pergamon, Oxford (1982) vol. 6, chapter 40.
3. F.G.A. Stone, *Accounts Chem.Res.*, 14 (1981) 318.
4. T.V. Ashworth, M.J. Chetcuti, L.J. Farrugia, J.A.K. Howard, J.C. Jeffery, R. Mills, G.N. Pain, F.G.A. Stone and P. Woodward, *ACS Symp.Ser.*, 155 (1981) 299.
5. F.G.A. Stone, *Inorg.Chim.Acta*, 50 (1981) 33.
6. F.G.A. Stone, *Kem.Kozlem.*, 56 (1981) 155.
7. G.L. Geoffroy, *Accounts Chem.Res.*, 13 (1980) 469.
8. G.L. Geoffroy, H.C. Foley, J.R. Fox and W.L. Gladfelter, *ACS Symp. Ser.*, 155 (1981) 111.
9. S. Kennedy, J.J. Alexander and S.G. Shore, *J.Organomet.Chem.*, 219 (1981) 385.
10. T.L. Hall and J.K. Ruff, *Inorg.Chem.*, 20 (1981) 4444.
11. J.R. Shapley, G.A. Pearson, M. Tachikawa, G.E. Schmidt, M.R. Churchill and F.J. Hollander, *J.Am.Chem.Soc.*, 99 (1977) 8064.
12. M.R. Churchill, F.J. Hollander, R.A. Lashewycz, G.A. Pearson and J.R. Shapley, *J.Am.Chem.Soc.*, 103 (1981) 2430.
13. M.R. Churchill and F.J. Hollander, *Inorg.Chem.*, 20 (1981) 4124.
14. P.A. Dawson, B.M. Peake, B.H. Robinson and J. Simpson, *Inorg.Chem.*, 19 (1980) 465.
15. A.K. Baev, J.A. Connor, N.I. El-Saied and H.A. Skinner, *J.Organomet. Chem.*, 213 (1981) 151.
16. G.A. Battiston, G. Bor, U.K. Dietler, S.F.A. Kettle, R. Rossetti, G. Sbrignadello and P.L. Stanghellini, *Inorg.Chem.*, 19 (1980) 1961.
17. A.A. Koridze, O.A. Kizas, N.M. Astakhova, P.V. Petrovskii and Y.K. Grishin, *J.Chem.Soc., Chem.Commun.*, (1981) 853.
18. D.H. Farrar, B.F.G. Johnson, J. Lewis, J.N. Nicholls, P.R. Raithby and M.J. Rosales, *J.Chem.Soc., Chem.Commun.*, (1981) 273.

19. F. Takusagawa, A. Fumagalli, T.F. Koetzle, G.R. Steinmetz, R.P. Rosen, W.L. Gladfelter, G.L. Geoffroy, M.A. Bruck and R. Bau, *Inorg.Chem.*, 20 (1981) 3823.
20. W.L. Gladfelter and G.L. Geoffroy, *Inorg.Chem.*, 19 (1980) 2579.
21. H.C. Foley and G.L. Geoffroy, *J.Am.Chem.Soc.*, 103 (1981) 7176.
22. J.R. Fox, W.L. Gladfelter and G.L. Geoffroy, *Inorg.Chem.*, 19 (1980) 2574.
23. S.A.R. Knox, J.W. Koepke, M.A. Andrews and H.D. Kaesz, *J.Am.Chem.Soc.*, 97 (1975) 3942.
24. J.R. Fox, W.L. Gladfelter, T.G. Wood, J.A. Smegal, T.K. Foreman, G.L. Geoffroy, I. Tavanaiepour, V.W. Day and C.S. Day, *Inorg.Chem.*, 20 (1981) 3214.
25. W.L. Gladfelter, J.R. Fox, J.A. Smegal, T.G. Wood and G.L. Geoffroy, *Inorg.Chem.*, 20 (1981) 3223.
26. D.E. Fjare and W.L. Gladfelter, *J.Am.Chem.Soc.*, 103 (1981) 1572.
27. J.S. Plotkin, D.G. Alway, C.R. Weisenberger and S.G. Shore, *J.Am.Chem.Soc.*, 102 (1980) 6156.
28. E.W. Burkhardt and G.L. Geoffroy, *J.Organomet.Chem.*, 198 (1980) 179.
29. S. Aime, D. Osella, L. Milone, G.E. Hawkes and E.W. Randall, *J.Am.Chem.Soc.*, 103 (1981) 5920.
30. G.L. Geoffroy and R.A. Epstein, *ACS Adv.Chem.Ser.*, 196 (1981) 132.
31. K. Bartl, R. Boese and G. Schmid, *J.Organomet.Chem.*, 206 (1981) 331.
32. A.A. Arduini, A.A. Bahsoun, J.A. Osborn and C. Voelker, *Angew.Chem.*, 92 (1980) 1058; *Angew.Chem.Int.Ed.Engl.*, 19(1980) 1024.
33. G. Doyle, *J.Molec.Catal.*, 13 (1981) 237.
34. H. Nishihara, T. Mori, T. Saito and Y. Sasaki, *Chem.Lett.*, (1980) 667.
35. H. Nishihara, T. Saito and Y. Sasaki, *Chem.Lett.*, (1981) 451.
36. E. Roland and H. Vahrenkamp, *Angew.Chem.*, 93 (1981) 714; *Angew.Chem.Int.Ed.Engl.*, 20 (1981) 679.
37. J.R. Moss and W.A.G. Graham, *J.Organomet.Chem.*, 23 (1970) C23.
38. P.C. Steinhardt, W.L. Gladfelter, A.D. Harley, J.R. Fox and G.L. Geoffroy, *Inorg.Chem.*, 19 (1980) 332.
39. M. Hidai, M. Orisaku, M. Ue, Y. Uchida, K. Yasufuku and H. Yamazaki, *Chem.Lett.*, (1981) 143.

40. W.L. Gladfelter, G.L. Geoffroy and J.C. Calabrese, *Inorg.Chem.*, 19 (1980) 2569.
41. A. Fumagalli, T.F. Koetzle and F. Takusagawa, *J.Organomet.Chem.*, 213 (1981) 365.
42. L. Farrugia, J.A.K. Howard, P. Mitrprachachon, F.G.A. Stone and P. Woodward, *J.Chem.Soc., Dalton Trans.*, (1981) 171.
43. L.J. Farrugia, J.A.K. Howard, P. Mitrprachachon, F.G.A. Stone and P. Woodward, *J.Chem.Soc., Dalton Trans.*, (1981) 1134.
44. M.I. Bruce, G. Shaw and F.G.A. Stone, *J.Chem.Soc., Dalton Trans.*, (1972) 1082; R. Mason, J. Zubieta, A.T.T. Hsieh, J. Knight and M.J. Mays, *J.Chem.Soc., Chem.Commun.*, (1972) 200; R. Mason and J. Zubieta, *J.Organomet.Chem.*, 66 (1974) 289.
45. R. Bender, P. Braunstein, J. Fischer, L. Ricard and A. Mitschler, *Nouv. J.Chim.*, 5 (1981) 81.
46. G. Longoni, M. Manassero and M. Sansoni, *J.Am.Chem.Soc.*, 102 (1980) 3242.
47. G. Longoni, M. Manassero and M. Sansoni, *J.Am.Chem.Soc.*, 102 (1980) 7974.
48. G. Longoni and F. Morazzoni, *J.Chem.Soc., Dalton Trans.*, (1981) 1735.
49. L.J. Farrugia, J.A.K. Howard, P. Mitrprachachon, F.G.A. Stone and P. Woodward, *J.Chem.Soc., Dalton Trans.*, (1981) 155.
50. L.J. Farrugia, J.A.K. Howard, P. Mitrprachachon, F.G.A. Stone and P. Woodward, *J.Chem.Soc., Dalton Trans.*, (1981) 162.
51. R. Pierantozzi, K.J. McQuade and B.C. Gates, *Stud.Surf.Sci.Catal.*, (1981) vol. 7, part B (*New Horiz.Catal.*), p. 941; *Chem.Abstr.*, 95 (1981) 226316.
52. L.J. Farrugia, J.A.K. Howard, P. Mitrprachachon, F.G.A. Stone and P. Woodward, *J.Chem.Soc., Dalton Trans.*, (1981) 1274.
53. D. Labroue, R. Queau and R. Poilblanc, *J.Organomet.Chem.*, 186 (1980) 101.
54. P. Lemoine, A. Girardeau, M. Gross, R. Bender and P. Braunstein, *J.Chem.Soc., Dalton Trans.*, (1981) 2059.

55. A. Fumagalli, G. Longoni, P. Chini, A. Albinati and S. Brückner, *J.Organomet.Chem.*, 202 (1980) 329.
56. L.M. Cirjak, J.-S. Huang, Z.-H. Zhu and L.F. Dahl, *J.Am.Chem.Soc.*, 102 (1980) 6623.
57. J.R. Shapley, S.J. Hardwick, D.S. Foose, G.D. Stucky, M.R. Churchill, C. Bueno and J.P. Hutchinson, *J.Am.Chem.Soc.*, 103 (1981) 7383.
58. E. Guggolz, M.L. Ziegler, W. Kalcher, J. Plank, D. Riedel and W.A. Herrmann, *Z.Naturforsch.*, 36b (1981) 1053.
59. J. Knight and M.J. Mays, *J.Chem.Soc.(A)*, (1970) 654.
60. A. Marinetti, E. Sappa, A. Tiripicchio and M. Tiripicchio Camellini, *Inorg.Chim.Acta*, 44 (1980) L183; E. Sappa, A. Tiripicchio and M. Tiripicchio Camellini, *J.Organomet.Chem.*, 199 (1980) 243.
61. E. Sappa, A.M. Manotti Lanfredi and A. Tiripicchio, *J.Organomet.Chem.*, 221 (1981) 93.
62. E. Sappa, M. Lanfranchi, A. Tiripicchio and M. Tiripicchio Camellini, *J.Chem.Soc., Chem.Commun.*, (1981) 995.
63. H. Beurich and H. Vahrenkamp, *Angew.Chem.*, 93 (1981) 128; *Angew.Chem.*, 20 (1981) 98.
64. L.R. Byers, V.A. Uchtman and L.F. Dahl, *J.Am.Chem.Soc.*, 103 (1981) 1942.
65. N.M. Boag, M. Green, R.M. Mills, G.N. Pain, F.G.A. Stone and P. Woodward, *J.Chem.Soc., Chem.Commun.*, (1980) 1171.
66. M. Green, J.A.K. Howard, R.M. Mills, G.N. Pain, F.G.A. Stone and P. Woodward, *J.Chem.Soc., Chem.Commun.*, (1981) 869.
67. M. Tachikawa, A.C. Sievert, E.L. Muetterties, M.R. Thompson, C.S. Day and V.W. Day, *J.Am.Chem.Soc.*, 102 (1980) 1725.
68. M. Tachikawa, R.L. Geerts and E.L. Muetterties, *J.Organomet.Chem.*, 213 (1981) 11.
69. V.G. Albano, D. Braga, S. Martinengo, P. Chini, M. Sansoni and D. Strumolo, *J.Chem.Soc., Dalton Trans.*, (1980) 52.
70. J.W. Lauher and K. Wald, *J.Am.Chem.Soc.*, 103 (1981) 7648.
71. J.E. Ellis, *J.Am.Chem.Soc.*, 103 (1981) 6106.

72. C.W. Bradford, W. van Bronswijk, R.J.H. Clark and R.S. Nyholm, *J.Chem. Soc. (A)*, (1970) 2889.
73. B.F.G. Johnson, D.A. Kaner, J. Lewis and P.R. Raithby, *J.Organomet. Chem.*, 215 (1981) C33.
74. B.F.G. Johnson, D.A. Kaner, J. Lewis and P.R. Raithby, *J.Chem.Soc., Chem.Commun.*, (1981) 753.
75. J.W.A. van der Velden, J.J. Bour, B.F. Otterloo, W.P. Bosman and J.H. Noordik, *J.Chem.Soc., Chem.Commun.*, (1981) 583.
76. G. van Koten, C.A. Schaap, J.T.B.H. Jastrzebski and J.G. Noltes, *J.Organomet.Chem.*, 186 (1980) 427.
77. R. Uson, A. Laguna; M. Laguna, P.G. Jones and G.M. Sheldrick, *J.Chem. Soc., Chem.Commun.*, (1981) 1097.
78. T.V. Ashworth, M. Berry, J.A.K. Howard, M. Laguna and F.G.A. Stone, *J.Chem.Soc., Dalton Trans.*, (1980) 1615.
79. T.V. Ashworth, M.J. Chetcuti, J.A.K. Howard, F.G.A. Stone, S.J. Wisbey and P. Woodward, *J.Chem.Soc., Dalton Trans.*, (1981) 763.
80. M. Green, D.R. Hankey, M. Murray, A.G. Orpen and F.G.A. Stone, *J.Chem. Soc., Chem.Commun.*, (1981) 689.
81. L. Busetto, M. Green, J.A.K. Howard, B. Hessner, J.C. Jeffery, R.M. Mills, F.G.A. Stone and P. Woodward, *J.Chem.Soc., Chem.Commun.*, (1981) 1101.
82. J.C. Jeffery, K.A. Mead, H. Razay, F.G.A. Stone, M.J. Went and P. Woodward, *J.Chem.Soc., Chem.Commun.*, (1981) 867.
83. M. Chetcuti, M. Green, J.A.K. Howard, J.C. Jeffery, R.M. Mills, G.N. Pain, S.J. Porter, F.G.A. Stone, A.A. Wilson and P. Woodward, *J.Chem.Soc., Chem.Commun.*, (1980) 1057.
84. H. Beurich and H. Vahrenkamp, *Angew.Chem.*, 90 (1978) 915; *Angew.Chem. Int.Ed.Engl.*, 17 (1978) 863.
85. P. Brun, G.M. Dawkins, M. Green, R.M. Mills, J.Y. Salaün, F.G.A. Stone and P. Woodward, *J.Chem.Soc., Chem.Commun.*, (1981) 966.
86. J.R. Shapley, J.T. Park, M.R. Churchill, C. Bueno and H.J. Wasserman, *J.Am.Chem.Soc.*, 103 (1981) 7385.



87. J.R. Fox, W.L. Gladfelter, G.L. Geoffroy, I. Tavanaiepour, S. Abdel-Maquid and V.W. Day, *Inorg.Chem.*, 20 (1981) 3230.
88. A. Marinetti, E. Sappa, A. Tiripicchio and M. Tiripicchio Camellini, *J.Organomet.Chem.*, 197 (1980) 335.
89. M.I. Bruce, J.R. Rodgers, M.R. Snow and F.S. Wong, *J.Chem.Soc., Chem. Commun.*, (1980) 1285.
90. E. Sappa, A. Tiripicchio and M. Tiripicchio Camellini, *J.Organomet.Chem.*, 213 (1981) 175.
91. E. Sappa, A. Tiripicchio and M. Tiripicchio Camellini, *Inorg.Chim.Acta*, 41 (1980) 11.
92. D. Osella, E. Sappa, A. Tiripicchio and M. Tiripicchio Camellini, *Inorg.Chim.Acta*, 42 (1980) 183.
93. R. Belford, M.I. Bruce, M.A. Cairns, M. Green, H.P. Taylor and P. Woodward, *Chem.Commun.*, (1970) 1159.
94. P. Braunstein, D. Matt, O. Bars, M. Louër, D. Grandjean, J. Fischer and A. Mitschler, *J.Organomet.Chem.*, 213 (1981) 79.
95. M.R. Churchill, C. Bueno and D.A. Young, *J.Organomet.Chem.*, 213 (1981) 139.
96. D.A. Young, *Inorg.Chem.*, 20 (1981) 2049.
97. E. Keller and H. Vahrenkamp, *Chem.Ber.*, 114 (1981) 1111.
98. R.J. Haines, N.D.C.T. Stein, M. Laing and P. Sommerville, *J.Organomet.Chem.*, 198 (1980) C72.
99. P. Braunstein, A. Tiripicchio, M. Tiripicchio-Camellini and E. Sappa, *Inorg.Chem.*, 20 (1981) 3586.
100. D. Seyferth, R.S. Henderson, J.P. Fackler and A.M. Mazany, *J.Organomet.Chem.*, 213 (1981) C21.
101. H. Vahrenkamp and E.J. Wucherer, *Angew.Chem.*, 93 (1981) 715; *Angew.Chem.Int.Ed.Engl.*, 20 (1981) 680.
102. S.A. Khattab, L. Marko, G. Bor and B. Marko, *J.Organomet.Chem.*, 1 (1965) 373.
103. D. Seyferth and R.S. Henderson, *J.Organomet.Chem.*, 204 (1981) 333.
104. B.M. Peake, P.H. Rieger, B.H. Robinson and J. Simpson, *Inorg.Chem.*, 20 (1981) 2540.

105. P. Braunstein, E. Sappa, A. Tiripicchio and M. Tiripicchio Camellini, *Inorg.Chim.Acta*, 45 (1980) 1191.
106. D.A. Lesch and T.B. Rauchfuss, *J.Organomet.Chem.*, 199 (1980) C6.
107. G. Huttner, J. Schneider, G. Mohr and J. von Seyerl, *J.Organomet.Chem.*, 191 (1980) 161.
108. L. Marko, *J.Organomet.Chem.*, 213 (1981) 271.
109. F. Richter and H. Vahrenkamp, *Angew.Chem.*, 90 (1978) 916; *Angew. Chem.Int.Ed.Engl.*, 17 (1978) 864.
110. F. Richter and H. Vahrenkamp, *Angew.Chem.*, 92 (1980) 66; *Angew. Chem.Int.Ed.Engl.*, 19 (1980) 65.
111. E. Röttinger and H. Vahrenkamp, *J.Organomet.Chem.*, 213 (1981) 1.
112. H. Vahrenkamp, D. Steiert and P. Gusbeth, *J.Organomet.Chem.*, 209 (1981) C17.
113. A.A. Pasynskii, I.L. Eremenko, Y.V. Rakitin, V.M. Novotortsev, V.T. Kalinnikov, G.G. Aleksandrov and Y.T. Struchkov, *J.Organomet.Chem.*, 165 (1979) 57.
114. A.A. Pasynskii, I.L. Eremenko, B. Orazsakhato, Y.V. Rakitin, V.M. Novotortsev, O.G. Ellert and V.T. Kalinnikov, *Inorg.Chim.Acta*, 39 (1980) 91.
115. A.A. Pasynskii, I.L. Eremenko, Y.V. Rakitin, B. Orazsakhato, V.M. Novotortsev, O.G. Ellert, V.T. Kalinnikov, G.G. Aleksandrov and Y.T. Struchkov, *J.Organomet.Chem.*, 210 (1981) 377.
116. A.A. Pasynskii, I.L. Eremenko, B. Orazsakhato, Y.V. Rakitin, V.M. Novotortsev, O.G. Ellert, V.T. Kalinnikov, G.G. Aleksandrov and Y.T. Struchkov, *J.Organomet.Chem.*, 214 (1981) 351.
117. A.A. Pasynskii, I.L. Eremenko, B. Orazsakhato, V.T. Kalinnikov, G.G. Aleksandrov and Y.T. Struchkov, *J.Organomet.Chem.*, 216 (1981) 211.
118. A.A. Pasynskii, I.L. Eremenko, B. Orazsakhato, Y.V. Rakitin, V.M. Novotortsev, O.G. Ellert, V.T. Kalinnikov, G.G. Aleksandrov and Y.T. Struchkov, *J.Organomet.Chem.*, 210 (1981) 385.
119. A.A. Pasynskii, I.L. Eremenko, B. Orazsakhato, V.T. Kalinnikov, G.G. Aleksandrov and Y.T. Struchkov, *J.Organomet.Chem.*, 214 (1981) 367.

120. D.F. Jones, U. Oehmichen, P.H. Dixneuf, T.G. Southern, J.-Y. Le Marouille and D. Grandjean, *J.Organomet.Chem.*, 204 (1981) C1;  
D.F. Jones, P.H. Dixneuf, T.G. Southern, J.-Y. Le Marouille, D. Grandjean and P. Guenot, *Inorg.Chem.*, 20 (1981) 3247.
121. D.F. Jones and P. Dixneuf, *J.Organomet.Chem.*, 210 (1981) C41.
122. M. Pfeffer, J. Fischer, A. Mitschler and L. Ricard, *J.Am.Chem.Soc.*, 102 (1980) 6338.
123. W.E. Newton and S. Otsuka, eds., *Molybdenum Chemistry of Biological Significance*, Plenum, New York (1980).
124. A.H. Gibson and W.E. Newton, eds., *Current Perspectives in Nitrogen Fixation*, Canberra (1981).
125. D. Coucouvanis, *Accounts Chem.Res.*, 14 (1981) 201.
126. G.J.S. Adam and M.L.H. Green, *J.Organomet.Chem.*, 208 (1981) 299.
127. A. Müller, R. Jostes, V. Flemming and R. Potthast, *Inorg.Chim.Acta*, 44 (1980) L33.
128. A. Müller, H. Bögge, H.-G. Tölle, R. Jostes, U. Schimanski and M. Dartmann, *Angew.Chem.*, 92 (1980) 665; *Angew.Chem.Int.Ed.Engl.*, 19 (1980) 654.
129. A. Müller, H. Bögge and U. Schimanski, *J.Chem.Soc., Chem.Commun.*, (1980) 91.
130. A. Müller, H. Bögge and T.K. Hwang, *Inorg.Chim.Acta*, 39 (1980) 71.
131. E. Königer-Ahlborn and A. Müller, *Angew.Chem.*, 88 (1976) 725; *Angew.Chem.Int.Ed.Engl.*, 15 (1976) 680.
132. R.N. Grimes, E. Sinn and R.B. Maynard, *Inorg.Chem.*, 19 (1980) 2384.
133. R.B. King, E.K. Nishimura and K.S. Raghu Veer, *Inorg.Chem.*, 19 (1980) 2478.
134. W.M. Maxwell, E. Sinn and R.N. Grimes, *J.Am.Chem.Soc.*, 98 (1976) 3490.
135. K.A. Gingerich, *Symp.Faraday Soc.*, 14 (1980) 109.
136. M.R. Churchill and J.P. Hutchinson, *Inorg.Chem.*, 20 (1981) 4112.