**NIObIUM ORGANOMETALLIC COMPOUNDS: ANALYSIS AND CLASSIFICATION OF
 CRYSTALLOGRAPHIC DATA**

CLIVE E. HOLLOWAY

Department of Chemistry, York University, 4700 Keele Street, Downsview,
 Ontario, M3J 1P3, Canada

MILAN MELNÍK

Department of Inorganic Chemistry, Slovak Technical University, CS 812 37,
 Bratislava, Czechoslovakia

(Present address: Department of Chemistry, York University, On sabbatical
 Leave)

CONTENTS

| | |
|------------------------------------|----|
| 1. INTRODUCTION | 2 |
| 2. MONONUCLEAR COMPOUNDS | 3 |
| A. Monocyclopentadienyl Compounds | 3 |
| B. Bis(cyclopentadienyl) Compounds | 7 |
| C. Cyclo-octatetraene Compounds | 10 |
| 3. HETEROBINUCLEAR COMPOUNDS | 16 |
| 4. HOMOLIGONUCLEAR COMPOUNDS | 22 |
| A. Binuclear Compounds | 22 |
| B. Trinuclear Compounds | 25 |
| C. Tetranuclear Compounds | 31 |
| 5. CONCLUSIONS | 32 |
| 6. REFERENCES | 36 |

ABBREVIATIONS

| | |
|--------------------|------------------------------------|
| $C_4H_{10}O_2PS_2$ | diethyldithiophosphate |
| C_8H_8 | cyclooctatetraene |
| $CNCMe_3$ | tert-butylisocyanide |
| cp | cyclopentadienyl |
| diars | ortho-phenylenebis(dimethylarsine) |
| dmpc | 1,2-bis(dimethylphosphino)ethane |
| dppe | 1,2-bis(diphenylphosphino)ethane |
| Et | ethyl |
| H_2CPh | benzyl |

| | |
|---------------------------------------|--|
| hx | hexagonal |
| m | monoclinic |
| Me | methyl |
| Me ₆ C ₆ | hexamethylbenzene |
| or | orthorhombic |
| Ph | Phenyl |
| Ph ₂ C ₂ | diphenylacetylene |
| π -Ph ₄ C ₄ | π -tetraphenylcyclobutadiene |
| rh | rhombic |
| tg | tetragonal |
| thf | tetrahydrofuran |
| tol | toluene |
| tph | π -N,2,3- η^2 - π -4,5,6- η^2 -3,4,5,6-tetraphenyl- -3,5-hexadiene-2-oneimine |
| tr | triclinic |
| trg | trigonal |

1. INTRODUCTION

The cyclopentadienyl radical is one of the most widely found π -electron donors, and the vast majority of niobium organometallic derivatives have at least one of these ligands. Since the halo-monocyclopentadienyl compounds of niobium can be precursors of a wide range of new derivatives, considerable attention has been paid to this area. Preparative and structural studies have been aimed at investigating the bonding modes of cyclopentadiene, and to determine the relationship between the bonding and reactivity towards unidentate ligands. Such systems provide useful models for more general reactions at the metal centre. In many of these derivatives metal-metal bonding can occur, which is also of considerable theoretical and practical interest.

Organometallic intramolecular coordination compounds containing π - and σ -bonded olefins, dienes and cyclopentadiene have been the subject of reviews by Omae (ref.1). Interactions of organometallic moieties with carbanions and other electron rich centres have been reviewed by Kerber (ref.2).

This review represents the first overview of organometallic compounds for niobium for which structures have been determined by x-ray crystallography. A brief survey of the structural data is given, and the factors governing the stereochemical interactions in the coordination sphere of niobium are discussed. The material included has been obtained

from reports published in primary journals up to the end of 1984, or to volume 101 of chemical abstracts. A general review of the structural data for niobium coordination compounds has been completed (ref.3), and this review serves to classify the organometallic structures and make comparisons between the organometallic and other complexes of niobium. The systems discussed are divided into mononuclear, hetero-binuclear, and homo-oligonuclear derivatives.

2. MONONUCLEAR COMPOUNDS

A. Monocyclopentadienyl Compounds

Structural data for monocyclopentadienyl niobium compounds are listed in Table 1. The crystal structure of $(\eta^5\text{-cp})\text{Nb}(\text{CO})_4$ is shown in Figure 1. The stereochemistry about the niobium is that of a regular square pyramid with the cyclopentadienyl ligand at the apex. There are two types of Nb-CO bonds, one with a metal-carbon bond length of 207.7(7)pm, and the other with a bond length 3.8pm longer at 211.5(8)pm. By contrast, the carbon-oxygen bond lengths are the reverse order at 114.5(9)pm and 111.2(10)pm respectively, such that the overall distance between the niobium atom and the oxygen atom are equal in both types. The niobium to cyclopentadiene distances (Table 1) are comparable to those found in other

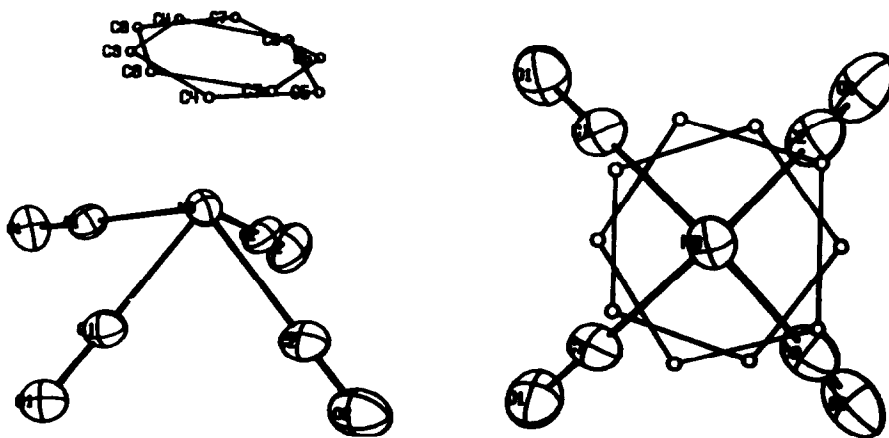

Figure 1. A schematic view of the crystal structure of $(\eta^5\text{-cp})\text{Nb}(\text{CO})_4$.
Reproduced with permission from Chem. Ber. (ref.4).

TABLE 1. STRUCTURAL DATA FOR MONONUCLEAR MONOCYCLOPENTADIENYL NIOBIUM ORGANOMETALLIC COMPOUNDS^a

| COMPOUNDS | CRYSTAL SPACE CLASS GROUP | Z | a (Å) b (Å) c (Å) | α (°) β (°) γ (°) | M-L (Å) | I-M-L L'-M-L (°) | REF. |
|--|---------------------------|---|-------------------------------------|---|---|---|------|
| $(\eta^5\text{-cp})\text{Nb}(\text{CO})_4$ | Pnma | 4 | 780.0(3) 1223.0(6) 1061.9(5) | 90 90 90 | OC ^b 209.6(8,19) cp 241.4(18,32) | 74.7(4,3) | 4 |
| $[(\eta^5\text{-cp})\text{Nb}^{\text{III}}(\text{CONMe}_2)_4\text{Cl}] \cdot [\text{Nb}_2\text{O}_7] \cdot (\text{thf})$ | Pnma | 4 | 1215.0(2) 1385.2(3) 2739.4(6) | | Cl 250.5(4) cp 237.9(13,18) C 220.6(10,4) O 166.5(11) (thf)O 239.4(12) Cl 238.0(4,7) | 89.3(5,6,5); 156.9(4) 78.5(3,6) 89.0(1,2); 164.3(2,3) 82.1(2,5); 97.8(3,2) | 5 |
| $(\eta^5\text{-cp})\text{Nb}(\text{PPh}_2)_2(\text{CO})(\text{H}_2)$ | m | 4 | 1574.5(5) 2131.9(5) 1093.5(5) | | OC 202(3) P 256.5(15,18) cp 244(3,3) | 130.7(4) 76.0(8,1.3) | 6 |
| $[(\eta^5\text{-cp})\text{Nb}^{\text{IV}}\text{C}_2\text{H}_3(\text{dippe})] \cdot (\text{tol})_2$ | tr | 2 | 911.2(3) 1199.6(3) 1711.3(5) | 70.40(2) 87.41(2) 80.32(2) | Cl 247.0(1,10) P 273.4(1,55) cp 241.3(4,49) | 86.40(4,1.07); 149.70(4) 80.73(4,11.73) | 7,8 |
| $[(\eta^5\text{-cp})\text{Nb}^{\text{III}}\text{C}_2\text{H}_2(\text{dmpe})]$ | m | 4 | 653.1(1) 1611.3(2) 1375.6(2) | 102.72(2) | c | 91.46(6) | 9 |
| $(\eta^5\text{-cp})\text{Nb}(\text{CO})(\text{Ph}_2\text{C}_2)_2$ | tr (P1) | 2 | 1172(2) 1180(2) 1006(2) | 100.5(5) 103.4(5) 78.6(5) | OC 200 cp 246(0,2) PhC 219(0,4) | d | 10 |

TABLE 1. (Continued - 2)

| COMPOUND | CRYSTAL SPACE CLASS GROUP | Z | a (pm) | | | α (°) | | | M-L (pm) | L-M-L L'-M-L (°) | REF. |
|--|------------------------------|-------------------|--------|-----------|---|-------|-----------|------------------------------|-------------|------------------------|-------|
| | | | a | b | c | α | β | γ | | | |
| (η ⁵ -cp)Nb(CO)(Ph ₂ C ₂). •(η-Ph ₃ C ₄) | m | F ₂ /c | 4 | 1152(2) | | | | | OC 211(3) | c | 11,12 |
| | | | | 1398(2) | | | 115.5(5) | cp 244(3,1) | | | |
| | | | | 2479(4) | | | | PhC 225(3,4) | | | |
| | | | | | | | | π-PhC 238(3,2) | | | |
| (η ⁵ -cp)Nb(CO)(η-Ph ₃ GeC≡CPh) ₂ | m | P $\bar{1}$ | 2 | 2426.2(5) | | | 96.4(2) | OC 204(2) | 106(0,1) | 13 | |
| | | | | 896.5(5) | | | 85.1(2) | C 218(2,3) | | | |
| | | | | 1110.6(5) | | | 95.9(2) | cp 244(2,3) | | | |
| (η ⁵ -cp)Nb(Ph ₃) (tph) | m | F ₂ /m | 4 | 1107.0(7) | | | | (H ₃ P)P 244.5(5) | c | 14 | |
| | | | | 2385.5(8) | | | | (tph)N 238(2) | | | |
| | | | | 1111.2(7) | | | 102.50(2) | (tph)C 236(2,35) | | | |
| | | | | | | | | cp 244(2,4) | | | |

a. Where more than one chemically equivalent distance or angle is present, the mean value is tabulated. The first number in brackets is the e.s.d. and the second is the maximum deviation from the mean value. b. The chemical identity of the coordinated atom or ligand. c. Not given. d. The mean values of the angles are: Ph₂C₂(centroid)-Nb-CO = 86 and 95(4)°; cp (centroid) -Nb-CO = 114(4)°; cp(centroid)-Nb-C₂Ph₂(centroid) = 117 and 125(4)°; Ph₂C₂-Nb-C₂Ph₂ = 107(4)°.

related niobium compounds. Inspection of the data in Table 1 reveals a more general relationship between the Nb-CO bond lengths and the C-O bond lengths, the former elongating as the latter shortens. Other examples are: $(\eta^5\text{-cp})\text{Nb}(\text{CO})(\pi\text{-Ph}_3\text{GeC}\equiv\text{CPh})_2$ (ref.13) Nb-C = 204pm, C-O = 117pm; $(\eta^5\text{-cp})\text{Nb}(\text{CO})(\text{Ph}_2\text{C}_2)_2$ (ref.10) Nb-C = 200pm, C-O = 120pm. Thus the distance between the niobium and the oxygen atoms stays almost invariant at about 320pm.

Aspinall and co-workers (ref.5) have prepared, and studied by x-ray crystallography, the molecule $[(\eta^5\text{-cp})\text{Nb}^{\text{III}}(\text{CNMe}_3)_4\text{Cl}]^+[\text{Nb}^{\text{V}}\text{OCl}_4(\text{thf})]^- \cdot \text{thf}$. This compound is the only example (Table 1) in which both an organometallic and a coordination species of niobium coexist in one crystal. The structure consists of discrete organometallic cations with niobium in an oxidation state of three and a formal coordination number eight, together with the inorganic anions with niobium in an oxidation state of five and a distorted octahedral environment, plus an uncoordinated molecule of tetrahydrofuran. The Nb^V-Cl bond length of 238.0(4,7)pm is shorter by about 12.5pm than that of the Nb^{III}-Cl bond length. This is in agreement with the expectation that metal-ligand bond lengths should be directly proportional to the coordination state, and inversely proportional to the oxidation state of the metal. In $(\eta^5\text{-cp})\text{Nb}^{\text{IV}}\text{Cl}_3(\text{dppe})$ (ref.8), the Nb^{IV}-Cl bond distance of 247.0(1)pm (mean value) follows the same trend, its value lying between that of the corresponding Nb^V-Cl and Nb^{III}-Cl bond lengths (ref.5).

The crystal and molecular structure of $(\eta^5\text{-cp})\text{NbCl}_2(\text{dmpe})$ is shown in Figure 2 where it can be seen that the 16-electron compound has the Nb atom located between two "non-equivalent" half sandwiches. In addition there are two chlorides which are bonded to the Nb atom with a Cl-Nb-Cl angle of 91.46(6)°. This is significantly less than the Cl-M-Cl angle in other 16-electron analogous metallocenes. The mean value of the Nb-Cl bond length in monocyclopentadienyl compounds (Table 1, 248pm) is quite comparable to that found in eight coordinated niobium coordination compounds (249pm) (ref.3). The same formal coordination number can be proposed for the organometallic derivatives $[(\eta^5\text{-cp})\text{Nb}(\text{CNMe}_3)_4\text{Cl}]^+$ (ref.5) and $(\eta^5\text{-cp})\text{NbCl}_3(\text{dppe})$ (ref.8), where chlorides are found as ligands.

The Nb-P bond distance is observed to decrease from 273.4(1,55)pm in $(\eta^5\text{-cp})\text{NbCl}_3(\text{dppe})$ (ref.8), through 256.5(15,18)pm in $(\eta^5\text{-cp})\text{Nb}(\text{PPh}_3)_2 \cdot (\text{CO})(\text{H})_2$ (ref.6), to 244.5(5)pm in $(\eta^5\text{-cp})\text{Nb}(\text{PH}_3)(\text{tph})$ (ref.14) which is the order of decreasing steric demand of the phosphine ligand itself, dppe > PPh₃ > PH₃.

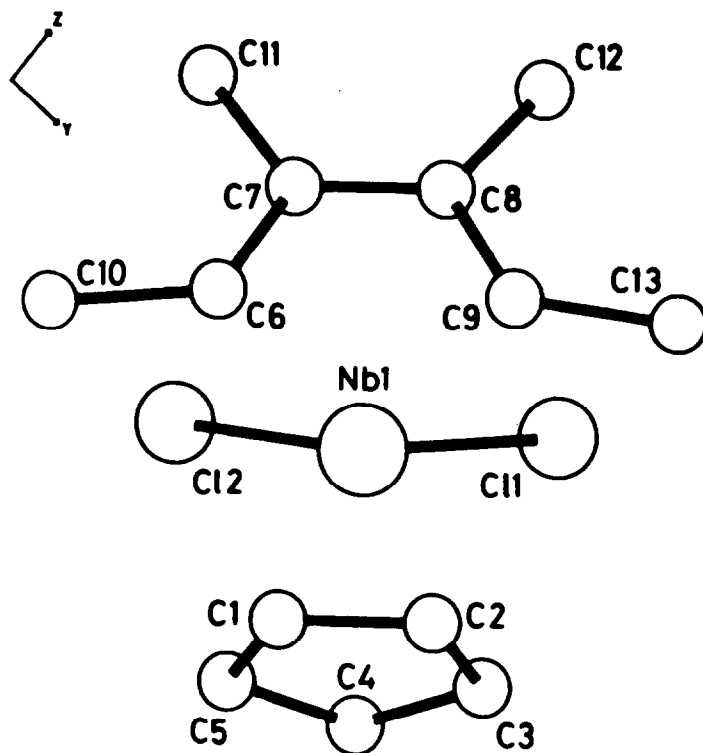

Figure 2. The molecular structure of $(\eta^5\text{-cp})\text{NbCl}_2(\text{dmpe})$.
 Reproduced with permission from J. Organomet. Chem. (ref.9).

The Nb-C (C_2Ph_2) distance 220.6pm (mean value) is 17.4pm shorter than that of Nb-C (C_4Ph_4), and even shorter than that of Nb-C (cp) at 242.5pm (Table 1). These differences are probably due to different π -acceptor abilities of the coordinated ligands (ref.10). The π -acceptor ability of the ligand will contribute to the Nb-L bond order in the sequence $\text{C}_2\text{Ph}_2 > \text{C}_4\text{Ph}_4 > \text{cp}$, the latter thus having the largest Nb-C bond length.

B. Bis(cyclopentadienyl) Compounds

From a structural point of view, niobium bis(cyclopentadienyl) compounds, summarized in Table 2, can be divided into four groups. In $(\eta^5\text{-cp})_2\text{Nb}(\text{BH}_4)$ (Ref.15) the niobium atom is η^5 bonded to two cp ligands, and the BH_4^- anion via two bridging hydrogen atoms. An x-ray investigation of the

compounds shows that the orthorhombic crystals are of the V-shaped sandwich type (Figure 3). The niobium atom has a distorted tetrahedral environment and a 16-electron valence shell. Usually, the geometry of the V-shaped, or clino-, sandwich is similar to that found in the other analogous niobium compounds listed in Table 2. It is interesting to note that while the cp(centroid)-Nb-cp(centroid) angle of 130° lies within the $128 - 143^\circ$ range of the other analogues, the Nb-C (cp) distance of $234(6)$ is one of the shortest reported. We have no explanation for this, however, as was mentioned in the original report (ref.15), the crystals are very unstable and the accuracy of the results is not high with a final value of $R = 12.8\%$.

The second group consists of $(\eta^5\text{-cp})_2\text{Nb}(\text{S}_2)(\text{C}_4\text{H}_{10}\text{O}_2\text{PS}_2)$ (ref.21), $(\eta^5\text{-cp})_2\text{Nb}(\text{S}_2)(\text{CH}_3)$ and $(\eta^5\text{-cp})_2\text{Nb}(\text{CS}_2)(\text{CH}_3)$ (ref.22), $(\eta^5\text{-cp})_2\text{Nb}(\text{CS}_2)$

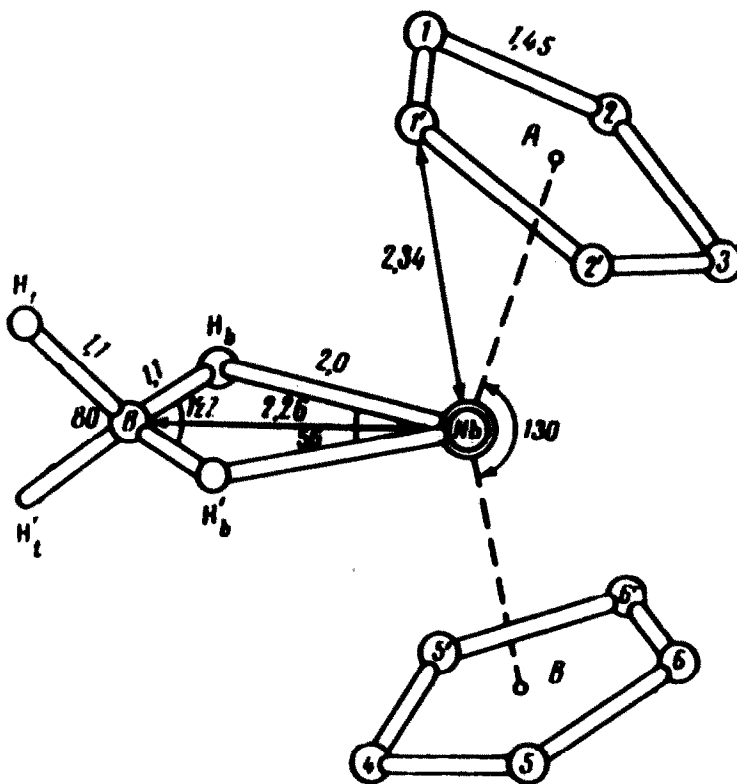

Figure 3. A view of the crystal structure of $(\eta^5\text{-cp})_2\text{Nb}(\text{BH}_4)$.
Reproduced with permission from Zh. Strukt. Khim. (ref.15).

(allyl) (ref.23), and $(\eta^5\text{-cp})_2\text{Nb}(\text{C}_2\text{H}_5)(\text{C}_2\text{H}_4)$ (ref.24), where in addition to the cp ligands, there is a bidentate and a unidentate ligand bonded to the niobium atom. In the first two examples the bidentate ligand is S_2 , while in the next two examples it is CS_2 bonded via the carbon and one sulphur atom, and in the last example it is C_2H_4 . The structure of the latter is shown in Figure 4 as a representative example of the group. The niobium is η^5 bonded to two cp rings, which are planar with 47.6° dihedral angle between them, making room in the horizontal mirror plane for a σ -bonded ethyl (C(13)) and a σ - π -bonded ethylene ligand (C(1) and C(2)), Figure 4. The mean Nb-C distance increases in the order $229.9(9)\text{pm}$ (C_2H_4) < $231.6(8)\text{pm}$ (C_2H_5) < $240.2(5)\text{pm}$ (cp) for both electronic and steric reasons. For a detailed discussion of the effects the reader is referred to the original work (ref.24).

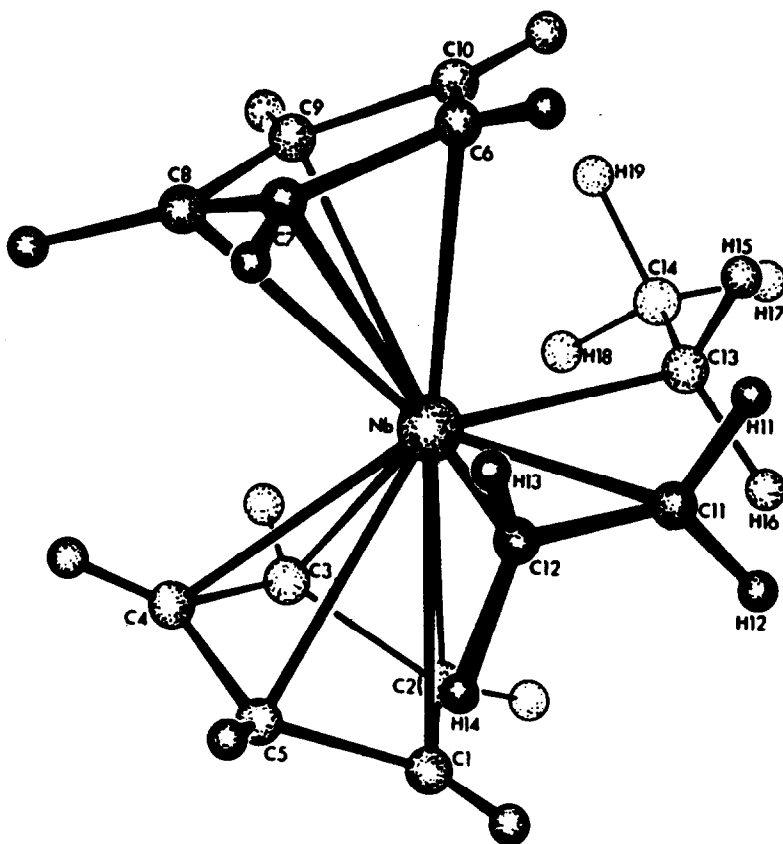

Figure 4. The molecular structure of $(\eta^5\text{-cp})_2\text{Nb}(\text{C}_2\text{H}_5)(\text{C}_2\text{H}_4)$.
Reproduced with permission from J. Am. Chem. Soc. (ref.24).

The third group consists of $(\eta^5\text{-cp})_2\text{NbH}_3$ (ref.18) and $(\eta^5\text{-cp})_2\text{NbO}_2\text{Cl}$ (ref.20) where in addition to the two cp rings there are three unidentate ligands in the coordination sphere of the metal atom.

The remaining bis(cyclopentadienyl) niobium compounds in Table 2 have the two cp rings together with two unidentate ligands.

Inspection of the data reveals three different types of ligands (atoms) bonded in the clino-sandwich molecules. Examples have been reported with the unidentate ligands: H, CO, CR, O, Cl, SH, and SR; and with the bidentate ligands: BH_4^- , C_2H_4 , S_2 , and CS_2 . In general, the mean value of the Nb-L bond distance increases with the van der Waals radius of the ligating atom. There is a variety of ligands which are bonded to niobium through C or S donor atoms, and the bond distances show systematic variations. The mean Nb-C distances decrease in the order: cp (240.3pm) > CH_3 (233.6pm) > C_2H_5 (231.6pm) > allyl (230.9pm) > C_2H_4 (229.8pm) > CH_2Ph (229.3pm) > CS_2 (222.4pm). The mean Nb-S distances decrease in the order SR (260.2pm) > SH (253.9pm) > S_2C (251.1pm) > S_2 (248.3pm). The nature of these differences indicates that there is a dependence on the electronic properties of the ligand and the steric interactions between ligands around the coordination sphere of the metal atom.

There is a relationship between the Nb-cp(centroid) bond length and the cp(centroid)-Nb-cp(centroid) angle such that as the bond lengthens the angle closes. For example, the distance and angle for $(\eta^5\text{-cp})_2\text{Nb}(\text{CO})_4\text{H}$ are 204pm and $143(3)^\circ$ respectively. The same parameters for $(\eta^5\text{-cp})_2\text{NbO}_2\text{Cl}$ are 213pm and $128(4)^\circ$ respectively. These two sets of values represent the limiting cases in Table 2. The variation can be explained in terms of steric hindrance within the coordination sphere, as the rings move further away with the same dihedral angle between them the "bite" angle at the metal atom closes up. There is a noticeable (2.2pm) difference between the mean Nb-C (cp) bond distance in Table 2 (240.3pm) and Table 1 (242.5pm), the monocyclopentadienyl Nb-cp bond distances being slightly longer.

C. Cyclooctatetraene Compounds

Two niobium compounds have been investigated where a cyclooctatetraene ligand is coordinated to the niobium atom. The relevant structural details are given at the end of Table 2. The structure of $[\eta^5\text{-cp}(\text{C}_8\text{H}_8)]\text{Nb}(\eta^4\text{-C}_8\text{H}_8)$ (diars) (ref.28) is illustrated in Figure 5. The cyclopentadienyl ring is exo to the niobium, and the phenyl substituent is endo, and this is the first instance where the geometry of this bicyclic ligand has been established.

The η^5 -bicyclic ligand bonds to Nb through C(21) - C(25), (Figure 5) and the mean Nb-C distance, 233(3)pm is shorter than those found between Nb-cp

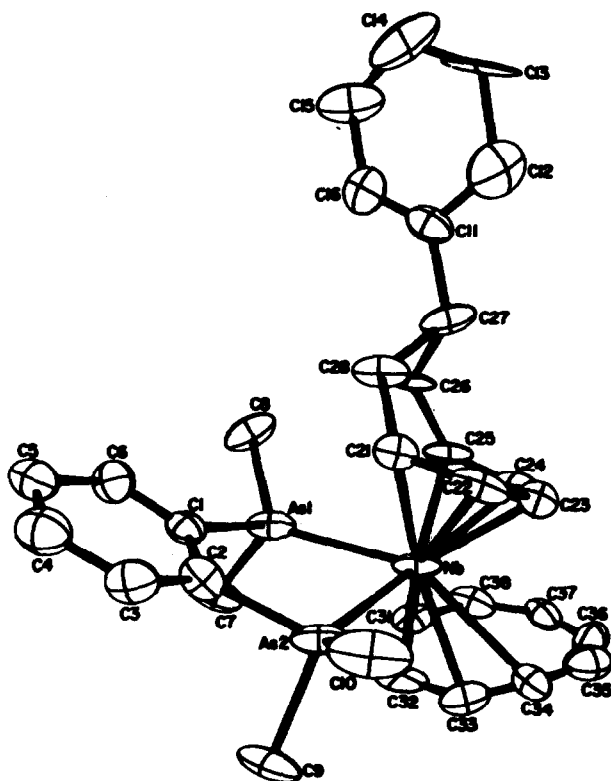

Figure 5. Molecular structure of $[n^5\text{-cp}(\text{C}_8\text{H}_8)]\text{Nb}(n^4\text{-C}_8\text{H}_8)(\text{diars})$.
 Reproduced with permission from J. Am. Chem. Soc. (ref.28).

or $\text{Nb}(\text{cp})_2$ (242.5 and 240.3pm respectively). On the other hand, the mean Nb-C ($n^4\text{-C}_8\text{H}_8$) distance at 248(4)pm is longer than those mentioned previously.

The structure of the tricyclooctatetraene niobium anion (ref.29) is shown in Figure 6. There are two types of cyclooctatetraene ligand. One has been described as n^4 -bonded, and the mean Nb-C distance of 243.8(15)pm is longer by about 7pm than that of the two n^3 -bonded cyclooctatetraene ligands (Table 2). These observations indicate that the variation of bond distance is not a simple function of steric crowding in the polyhedra. The significance, if any, of this observation cannot be definitely evaluated on the basis of the existing data. It does, however, suggest directions for further experimental work.

TABLE 2. STRUCTURAL DATA FOR MONONUCLEAR BIS(CYCLOPENTADIENYL) NIOBIUM ORGANOMETALLIC COMPOUNDS^a

| COMPOUND | CRYSTAL SPACE CLASS | Z | a (Å) | b (Å) | c (Å) | α (°) | β (°) | γ (°) | M-L (Å) | M-cp (centroid) (Å) | I-H-L cp-M-cp (°) | REF. |
|---|---------------------|---|-----------|-------|---------|--------------|-------------|--------------|------------------------|---------------------|------------------------------|------|
| $(\eta^5\text{-cp})_2\text{Nb}^{\text{III}}(\text{BH}_4)$ | or | 4 | 1356.2(6) | | | | | | cp ^b 234(6) | | 56 ^c | 15 |
| | | | 932.7(5) | H | 200(10) | | | | | | 130 | |
| | | | 792.3(5) | B | 226(6) | | | | | | | |
| $(\eta^5\text{-cp})_2\text{Nb}^{\text{III}}(\text{CO})\text{H}$ | tr | 2 | 1163(2) | | | 112.0(5) | | | OC 204(4) | 204 | 104(3,3) ^e | 16 |
| | | | 791(2) | (P1) | | 98.7(5) | | | cp 236(4,2) | | 143(3) | |
| $(\eta^5\text{-cp})_2\text{Nb}^{\text{III}}(\text{CO})\text{SH}$ | rh | 4 | 594(2) | | | 92.0(5) | | | H 150 | | 37 ^d | |
| | | | 654.4(5) | | | | | | OC 202(1) | 205 | 92.3(5) ^f | 17 |
| | | | 1281.5(5) | | | | | | cp 238(2,10) | | not given | |
| $(\eta^5\text{-cp})_2\text{NbH}_3$ | | 8 | 1253.1(5) | | | | | | S 253.9(4) | | 45 ^d | |
| | | | 1101.2(5) | | | | | | H 168(6,8) | 205.9 | 63(3,2); 126(3) ^g | 18 |
| | | | - | | | | | | cp 237.5(4,18) | | 141.6 | |
| $(\eta^5\text{-cp})_2\text{Nb}^{\text{IV}}\text{Cl}_2$ | m | 8 | 1496.0(5) | | | | | | Cl 247.0(4,6) | 209 | 85.6(2,1) ^h | 19 |
| | | | 1374(2) | | | | | | cp 239(3,6) | | 130.3(0,6) | |
| | | | 1221(2) | | | | | | | | | |
| $(\eta^5\text{-cp})_2\text{Nb}^{\text{V}}(\text{O}_2)\text{Cl}_2$ | m | 8 | 1316(2) | | | 107.7(1) | | | | | | 20 |
| | | | 1781(1) | | | | | | Cl 248.3(2) | 213(1) | 43.6(3) ⁱ | |
| | | | 634.3(5) | | | 138.28(5) | | | O 198(1,2) | | 128.4(4,3) | |
| | | | 2615.6(6) | | | | | | cp 244(2,3) | | | |

TABLE 2. (Continued - 2)

| COMPOUNDS | CRYSTAL SPACE CLASS | Z | a (pm) b (pm) c (pm) | α (°) β (°) γ (°) | M-L (pm) | M-cp (centroid) (pm) | L-H-L cp-M-cp (°) | REF. |
|--|---------------------|----|------------------------------------|---|---|----------------------|---|------|
| (η^5 -cp) ₂ Nb(S ₂)(C ₄ H ₁₀ O ₂ PS ₂) | m | 4 | 1456.4(3) 1740.9(6) 750.6(2) | 103.64(2) | (S ₂)S 249.3(4,36) S 260.2(4) cp 243(2,3) | 211(1,1) | 47.9(2); 69.7(2) ^j 128.4(2) | 21 |
| (η^5 -cp) ₂ Nb(S ₂)(CH ₃) | m | 4 | 1152.1(2) 1326.4(5) 748.9(1) | 90.90(2) | (S ₂)S 247.4(3,42) (H ₃ C)C 232.7(11) cp 241.8(9,26) | 211.0(0,2) | 47.9(2); 75(2) ^k 130.1 51.1 ^d | 22 |
| (η^5 -cp) ₂ Nb(CS ₂)(CH ₃) | m | 4 | 1281.7(3) 1216.1(8) 748.2(3) | 90.95(2) | (S ₂)C 220.6(8) (CS ₂)S 250.3(8) (H ₃ C)C 234.6(8) cp 239.8(8,28) | 210.1(0,8) | 4 131.9(5) 49.1 ^d | 22 |
| (η^5 -cp) ₂ Nb(CS ₂)(allyl) ^m | or | 8 | 759(1) 1360(1) 2647(2) | | (S ₂)C 224.1(21) (CS ₂)S 251.8(9) (allyl)C 230.9(31) cp 242.7(25,59) | | m 133.0 m 133.3 | 23 |
| (η^5 -cp) ₂ Nb(C ₂ H ₅)(C ₂ H ₄) | tg | 16 | 1648.1(2) - 1818.6(2) | | (H ₅ C ₂)C 229.9(9,22) (H ^δ C ^δ)C 231.6(8) cp 240.2(5,28) | 209.6 | 35.6(3); 74.8(3) ⁿ not given 47.6d | 24 |

TABLE 2. (Continued - 3)

| COMPOUNDS | CRYSTAL SPACE CLASS GROUP | Z | a (Å) b (Å) c (Å) | α (°) β (°) γ (°) | M-L (Å) | M-cp (centroid) (Å) | I-H-L cp-M-cp (°) | REF. |
|---|---------------------------|---|-------------------------------------|---|--|---------------------|--------------------------------|------|
| $(\eta^5\text{-cp})_2\text{Nb}^{\text{IV}}(\text{CH}_2\text{Ph})_2^{\text{O}}$ | or $P2_12_12_1$ | 8 | 884.4(1) 2153.2(2) 1933.1(2) | | C 230.6(7,1) cp 240.8(9,46) | | 79.3(2) ^o 133.1 | 25 |
| $(\eta^5\text{-cp})_2\text{Nb}(\text{O})\{\text{C}_7\text{H}_5(\text{CF}_3)_2\}$ | m $P2_1/n$ | 4 | 798.3(2) 2760.0(7) 868.9(2) | 113.22(2) | O 163(3) C 227(4) cp 246(5,11) | | 78.6(3) ^o 133.2 | 26 |
| $(\eta^5\text{-cp})_2\text{Nb}^{\text{IV}}(\sigma\text{-CH}_2\text{C}_6\text{H}_4)_2$ | or $Pmn2$ | 8 | 3198.5(9) 1087.5(3) 1052.7(3) | | (H ₂ C)C 229.7 cp 241(0,4) | 210 | 83.0 ^g 135.3 | 27 |
| $[(\eta^5\text{-cp})_2\text{Nb}^{\text{V}}(\sigma\text{-CH}_2\text{C}_6\text{H}_4)_2] \cdot (\text{BF}_4)$ | m $P2_1/n$ | 4 | 1360.2(6) 1293.4(5) 1262.3(5) | 110.26(3) | (H ₂ C)C 225.0(4,1) cp 241.8(4,24) | 210 | 106.3(1) ^g 131.0 | 27 |
| $[(\eta^5\text{-cp})_2\text{Nb}^{\text{III}}(\sigma\text{-CH}_2\text{C}_6\text{H}_4)_2] \cdot [\text{Nb}(\text{18-crown-6})(\text{tHf})_2]$ | tr $P\bar{1}$ | 2 | 1677(8) 1468(3) 1253(2) | 66.2(2) 85.4(3) 66.2(3) | (H ₂ C)C 232(3,3) cp 238(6,12) | 208(0,2) | 80(1) ^g 136.0 | 27 |

TABLE 2. (Continued - 4)

| COMPOUND | CRYSTAL SPACE CLASS | Z | a (Å) b (Å) c (Å) | α (°) β (°) γ (°) | M-L (Å) | M-cp (centroid) (Å) | L-H-L cp-M-cp (°) | REF. |
|---|---------------------|--------------------|--|---|--|---------------------|---|------|
| $\{n^5\text{-cp}(\text{C}_6\text{H}_6)\text{Nb}\{n^4\text{-C}_6\text{H}_6\} \cdot (\text{diars})\}$ | m | P2 ₁ /c | 898.1(16) 3193.0(26) 1217.7(7) | 106.97(8) | $(n^4)\text{C } 248(4,24)$ $(n^5)\text{C } 233(3,5)$ As 268.3(2,14) | | 75.1 ^f 131.1 ^g | 28 |
| $[(n^4\text{-C}_6\text{H}_6)\text{Nb}^{-1}(n^3\text{-C}_6\text{H}_6)_2] \cdot (\text{AsPh}_4)$ | m | P2 ₁ /c | 1299.6(16) 2237.7(26) 1437.1(23) | 115.51(11) | $(n^3)\text{C } 237.5(13,142)$ $(n^3)\text{C } 236.0(13,133)$ $(n^4)\text{C } 243.8(15,245)$ | | | 29 |

a. Where more than one chemically equivalent distance or angle is present, the mean value is tabulated. The first number in brackets is the e.s.d., and the second is the maximum deviation from the mean value.

b. The chemical identity of the coordinated atom or ligand. c. The value of the H-Nb-N angle.

d. The value of the dihedral angle between the ring planes. e. The value of the O-Nb-C angle; the H-Nb-O value = 90(3)°.

f. The value of the S-Nb-O angle. g. The value of the H-Nb-H angles.

h. The value of the Cl-Nb-Cl angle. i. The value of the O-Nb-O angle; Cl-Nb-O = 78.1(3,1) and 121.7(3,2)°; O-Nb-O (midpoint) = 109.6(4,9)°; cp-Nb-Cl = 102.4(4,1,2)°; Cl-Nb-O₂(midpoint) = 100.1(3,2)°. j. The values of S₂-Nb-S₂ and S₂-Nb-S angles. k. The values of S₂-Nb-S₂ and S₂-Nb-CH₃ angles. l. The values of angles are: (CS₂)S-Nb-C(CH₃) = 77.6°; (CS₂)S-Nb-C(CS₂) = 41.1°; (CS₂)O-Nb-C(CH₃) = 118.6°. m. There are two independent monomers. The values of angles are: (CS₂)S-Nb-C(allyl) = 76.1°; (CS₂)S-Nb-S(CS₂) = 41.8°; (CS₂)O-Nb-C(allyl) = 118.6°. n. The values of (H₂C₂)O-Nb-C(C₆H₆) and (H₂C₂)O-Nb-C(C₆H₆), respectively. o. There are two independent molecules. The value of (PhCH₂)O-Nb-C(PhCH₂) angle. p. The value of the O-Nb-C angle. q. The value of the CH₃-Nb-CH₃ angle. r. The value of the As-Nb-As angle; the As-Nb-cp(centroid) angle = 112.3(0,2,7)°; the As-Nb-C₆H₆(centroid) angle = 105.0(0,9,5)°; the O-Nb-C angle = 36.1(2,2,4)°. s. The value of the n^4 (ring)-Nb- n^4 (ring) angle.

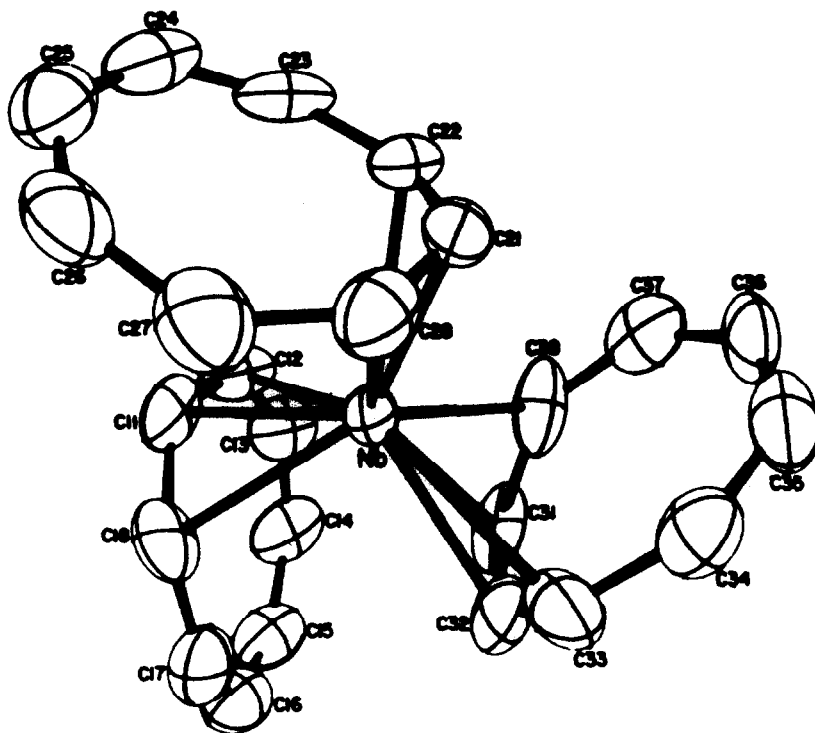

Figure 6. The crystal structure of $[(\eta^4\text{-C}_8\text{H}_8)\text{Nb}(\eta^3\text{-C}_8\text{H}_8)_2]^-$.
 Reproduced with permission from J. Am. Chem. Soc. (ref.29).

3. HETEROBINUCLEAR COMPOUNDS

Structural data for heterobinuclear compounds are summarised in Table 3. There are several types of bridged systems in this group. The crystal structure of the $[(\eta^5\text{-cp})\text{Nb}(\text{SnPh}_3)(\text{CO})_3]^-$ anion (ref.30) is the only example with one cp ligand. The $[\text{Nb}(\text{SnPh}_3)(\text{CO})_3]$ moiety in the anion has tetrahedral geometry, with the niobium at the top of the pyramid and at 119.3pm from the centre of the almost perfect plane described by the three CO ligands and the Sn atom. The mean Nb-C (CO) of distance of 208.6(15)pm is about 2.5pm longer than that found in the monocyclopentadienyl compounds listed in Table 1. On the other hand, the value 241.9pm for Nb-C (cp) distance is very near to the 242.5pm (mean value) found in the monocyclopentadienyl compounds in Table 1.

The molecule of $[(\eta^5\text{-cp})_2\text{Nb}\{\text{HgS}_2\text{CN}(\text{C}_2\text{H}_5)_2\}_3]$ (ref.31) consists of a rhomboidal metal cluster, NbHg_3 , which is nearly planar with the angle between the two NbHg_2 triangles of only 5° , as shown in Figure 7. The Nb-Hg bond lengths are compatible with a single bond (Table 3).

The niobium(III) atom in $(\eta^5\text{-C}_6\text{H}_4\text{Me})_2\text{Nb}(\text{CO})\text{SnCl}_3$ (ref.32) and $(\eta^5\text{-cp})_2\text{Nb}(\text{CO})\text{SnPh}_3$ (refs.32, 33) is η^5 -bonded to two cp rings, (with a 42.2° and 38.9° dihedral angle between the rings). The Sn atom is bound to the Nb(III) atom to form a wedge in the open side of the clino-sandwich. It is interesting to note that as the Sn-Nb bond length increases by 6.1pm from 276.4(1)pm in the former, the Nb-C (cp) bond length decreases by 6.0pm from 240pm in the former.

An x-ray investigation of $(\eta^5\text{-cp})_2\text{Nb}(\mu\text{-CO})_2\text{Mo}(\text{CO})\text{cp}$ (ref.34) shows an unusual coordination of the carbonyl groups. The dihedral angle between the two cp rings coordinated to niobium is 49° , giving enough room for the molybdenum atom to bond to the niobium with a bond length of 307.3(1)pm, plus two carbonyl groups to bridge asymmetrically between the two metal atoms. One of the carbonyls is bonded through the carbon atom only (Nb-C = 253pm, and Mo-C = 202pm), and the other is σ -bonded to the molybdenum (Mo-C = 194.4pm) and π -bonded to the niobium (Nb-C = 222pm, Nb-O = 226pm). The remaining ligands are bonded in the normal manner.

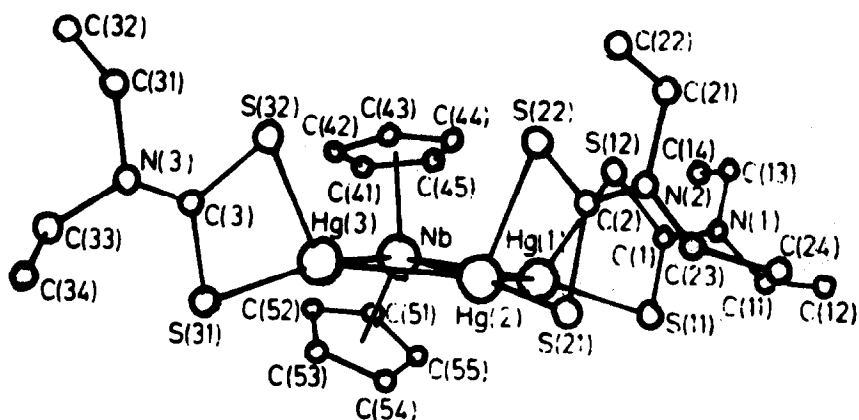

Figure 7. The Crystal Structure of $[(\eta^5\text{-cp})_2\text{Nb}\{\text{HgS}_2\text{CN}(\text{C}_2\text{H}_5)_2\}_3]$.
Reproduced with permission from J. Chem. Soc. Dalton Trans. (Ref.31).

One of the most common structures for the heterobinuclear niobium compounds is one in which a triangular Nb-H-M group is found, for example $(\eta^5\text{-cp})_2\text{Nb}(\text{CO})(\mu\text{-H})\text{Ni}(\text{CO})_3$ (ref.35); $(\eta^5\text{-cp})_2\text{Nb}(\text{CO})(\mu\text{-H})\text{Zn}(\text{BH}_4)_2$ (ref.36); $(\eta^5\text{-cp})_2\text{Nb}(\text{CO})_2(\mu\text{-H})\text{Fe}(\text{CO})_4$ (ref.37); $(\eta^5\text{-cp})_2\text{Nb}(\text{CO})(\mu\text{-H})(\eta^5\text{-cp})\text{Mn}(\text{CO})_2$ (ref.38); and $(\eta^5\text{-cp})_2\text{Nb}(\text{CO})(\mu\text{-H})(\eta^5\text{-cp})\text{V}(\text{CO})_3$ (ref.39). Another common type has a semi-bridged carbonyl group between the niobium atom and the other metal atom, for example: $(\eta^5\text{-cp})_2\text{Nb}(\text{CO})(\mu\text{-CO})\text{Mn}(\text{CO})_4$ (ref.35); and $(\eta^5\text{-cp})_2\text{Nb}(\text{CO})(\mu\text{-CO})\text{Co}(\text{CO})_3$ (ref.40). The crystal structure of the niobium-nickel hydrogen bridged derivative (ref.35) is shown in Figure 8 as a representative example. The compound contains a clino-sandwich biscyclopentadienyl niobium carbonyl, hydride bridged to the nickel carbonyl moiety ($\text{Nb-H} = 183\text{pm}$ and $\text{Ni-H} = 168\text{pm}$). Interestingly, the Nb-C (cp) distances in this series of compounds is almost constant at a mean value of 238.2pm while the other distances vary over a range (Table 3).

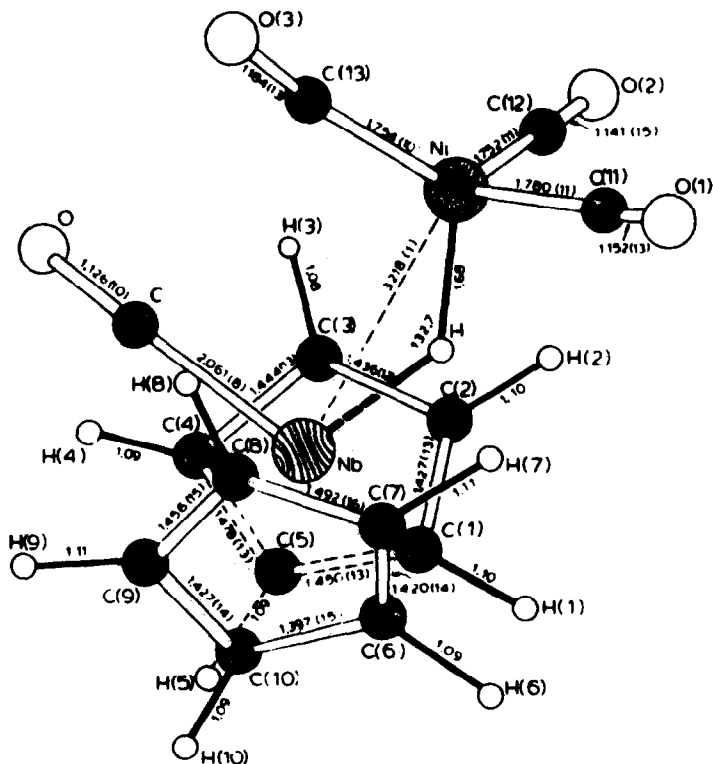

Figure. 8. Molecular structure of $(\eta^5\text{-cp})_2\text{Nb}(\text{CO})(\mu\text{-H})\text{Ni}(\text{CO})_3$.
Reproduced with permission from J. Organomet. Chem. (ref.35).

TABLE 3. STRUCTURAL DATA FOR HETEROBINUCLEAR NIOBIUM ORGANOMETALLIC COMPOUNDS^a

| COMPOUNDS | CRYSTAL SPACE CLASS | Z | a (pm) | b (pm) | c (pm) | α (°) | β (°) | γ (°) | Nb-L (pm) | Nb-M (pm) | Nb-L-M (°) | M-Nb-L (°) | Cp ring planes (°) | REF. |
|---|---------------------|--------------------|--------|-------------|-------------|--------------|-------------|--------------|--|--------------------------|------------|--|----------------------------------|------|
| $[(\eta^5\text{-cp})\text{Nb}(\text{SnPh}_3)_2(\text{CO})_3](\text{NEt}_4)$ | m | P2 ₁ /n | 4 | 1383.8(9) | 1520.6(18) | 1791.8(14) | 97.89(6) | | OC ^b 208.6(15,44) cp 241.9 | Sn ^b 282.0(2) | - | - | 70.7(4,1,6) | 30 |
| $[(\eta^5\text{-cp})_2\text{Nb}(\text{HgS}_2\text{CN})_2(\text{C}_2\text{H}_5)_2]_3$ | m | P2 ₁ /n | 4 | 1230.2(10) | 1838.5(11) | 1607.7(5) | 108.18(5) | | cp 241.(3,6) | Hg 279.0(3,18) | - | - | 62.3(1,2); 124.4(1) ^d | 31 |
| $[(\eta^5\text{-C}_9\text{H}_7\text{Me})_2\text{Nb}^{\text{III}}(\text{CO})_2(\text{O})\text{Sn}_2\text{Cl}_3]$ | m | P2 ₁ /n | 4 | 893.69(15) | 1335.89(12) | 1392.92(20) | 99.490(14) | | OC 203.1(9) cp 240 | Sn 276.4(1) | - | - | not given | 32 |
| $[(\eta^5\text{-cp})_2\text{Nb}^{\text{III}}(\text{CO})_2(\text{O})\text{SnPh}_3]$ | m | P2 ₁ /n | 4 | 1010.21(21) | 1746.33(32) | 1424.73(29) | 95.578(16) | | OC 205(2) cp 234(5) | Sn 282.5(2) | - | - | 88.8(2) 42.2 | 32 |
| $[(\eta^5\text{-cp})_2\text{Nb}(\mu\text{-CO})_2(\text{O})\text{Sn}(\text{CO})\text{cp}]$ | or | Pbca | 8 | 1274.8(5) | 1674.5(6) | 1431.4(7) | | | (μCO)O 226(1) OC 222(1) OC 253(1) cp 237-248 | Nb 307.3(1) | not given | not given | not given | 34 |
| $(\eta^5\text{-cp})_2\text{Nb}^{\text{III}}(\text{CO})_2(\mu\text{-CO})\text{Mn}(\text{CO})_4$ | m | P2 ₁ /c | 4 | 829.2(3) | 1623.2(5) | 1161.5(4) | 92.40(2) | | OC 206.1(4) OC _{br} 278.1(5) cp 239.7(5,48) | Mn 317.6(1) | not given | 35.1(1); 81.2(1) ^e 44.2(5) | not given | 35 |
| $(\eta^5\text{-cp})_2\text{Nb}^{\text{III}}(\text{CO})_2(\mu\text{-H})\text{Ni}(\text{CO})_3$ | m | P2 ₁ /c | 4 | 775.4(2) | 1605.6(4) | 1203.6(3) | 99.24(2) | | $\mu\text{-H}$ 183 OC 206.1(8) cp not given | Ni 321.8(1) | 132.7 | 22.6(2); 74.6(2) ^f 37.8 | 132.7 | 35 |

TABLE 3. (Continued - 2)

| COMPOUNDS | CRYSTAL SPACE CLASS | Z | a (pm) b (pm) c (pm) | α (°) β (°) γ (°) | Nb-L (pm) Nb-H (pm) | Nb-H (pm) | Nb-L-M (°) M-Nb-L (°) Cp ring planes (°) | REF. |
|---|---------------------|---|-------------------------------------|---|--|--------------------------|--|------|
| $\{(\eta^5\text{-cp})_2\text{Nb}^{\text{III}}\text{H}_4\cdot(\text{CO})\}_2$ | m | 4 | 1199.8(2) 1494.8(4) 1519.1(3) | 110.75(2) | $\mu\text{-H}$ 175.2 $\mu\text{-H}$ 182.7 OC 206.2(14) OC 202.3(14) cp 237(0,1) | Mb 357.9 Mb 356.5 | 141;133 97.6;100.38 41.4;43.0 | 35 |
| $(\eta^5\text{-cp})_2\text{Nb}(\text{CO})(\mu\text{-H})\cdot\text{Zr}(\text{Et})_2 \cdot 0.5\text{C}_6\text{H}_6$ | tr | 2 | 810.5(2) 935.0(2) 1125.2(2) | 89.65(1) 95.49(1) 94.33(2) | OC 205.8(4) $\mu\text{-H}$ 174.6 cp 238 | Zn 282.9(2) | 107 h 39.3 | 36 |
| $(\eta^5\text{-cp})_2\text{Nb}(\text{CO})(\mu\text{-H})\cdot\text{Re}(\text{CO})_4$ | m | 4 | 783.5(3) 1350.8(2) 1516.6(2) | 97.05(2) | $\mu\text{-H}$ 191(3) OC 205.7(4) cp 237.6(4,49) | Re 332.4(1) | 141.3(23) 17.6(11);82.4(1) ¹ 43.7 | 37 |
| $(\eta^5\text{-cp})_2\text{Nb}(\text{CO})(\mu\text{-H})\cdot(\eta^5\text{-cp})\text{Mn}(\text{CO})_2^j$ | | 4 | 908.8(2) 1423.9(4) 1280.1(3) | 95.03(2) | $\mu\text{-H}$ 198(8) OC 203.5(10) cp 238.3(10,59) | Mn 333.0(2) | 141(5) 100(3) | 38 |
| $(\eta^5\text{-cp})_2\text{Nb}(\text{CO})(\mu\text{-H})\cdot(\eta^5\text{-cp})\text{V}(\text{CO})_3^k$ | | 4 | 1103.3(4) 1320.6(5) 1476.3(5) | 68.90(3) 71.17(3) 68.91(3) | $\mu\text{-H}$ 206(18) OC 202.4(15) cp 238.6(18,92) $\mu\text{-H}$ 187(15) OC 203.8(22) cp 238.5(21,70) | V 372.5(4) V 370.1(3) | 173(8) 70(5) 41.8 155(8) | 39 |

TABLE 3. (Continued - 3)

| COMPOUND | CRYSTAL SPACE CLASS | Z | a (pm) | b (pm) | c (pm) | α (°) | β (°) | γ (°) | Nb-L (pm) | Nb-M (pm) | Nb-L-M (°) M-Nb-L (°) Cp ring planes (°) | REF. |
|--|----------------------|---|-----------|-----------|-----------|--------------|-------------|--------------|--|---------------|--|------|
| $(\eta^5\text{-cp})_2\text{Nb}(\text{CO})(\mu\text{-CO})$ ·Ob(CO) ₃ | or Pbcu | 8 | 1382.1(6) | 1335.2(5) | 1614.2(6) | | | | OC 205.8(4) O ₃ 253.1(4) cp 238.3(4,53) | Ob 299.2(1) | 85.8(1) 36.7(1); 76.0(1) ^a 44.6 | 40 |
| $(\eta^5\text{-C}_5\text{H}_5\text{Me})_2\text{Nb}^{\text{III}}$ ·(CH ₃ SiMe ₃) $(\eta^2\text{-CO})_2$ | m P2 ₁ /c | 4 | 1664.7(9) | 700.5(2) | 1546.8(7) | 91.43(4) | | | (CO) ₂ C 214.4(7) (CO) ₂ O 217.3(4) cp not given | Si not given | not given | 41 |
| $[(\eta^5\text{-cp})_2\text{Nb}^{\text{V}}$ ·(SiMe ₃) ₂] ₂ Ni (BF ₄) ₂ ·2H ₂ O | m P2 ₁ /b | 4 | 1144(1) | 3356(3) | 833(1) | 92.7(1) | | | S 247.8(9,10) cp 243(4,10) | Ni 277.0(5,5) | 72.5(3,2) | 42 |
| $(\eta\text{-C}_6\text{H}_5)(\eta^5\text{-cp})_2\text{Nb}$ ·($\mu\text{-CS}_2$) $(\text{CO})_5$ | m P2 ₁ | 4 | 1293.5(4) | 1274.2(4) | 1456.5(4) | 103.27(3) | | | (S ₂)C 211(8) (CS ₂)S 252(3) C 238(10,8) cp 236(9,11) | - n | 85.9 | 44 |

a. Where more than one chemically equivalent distance or angle is present, the mean value is tabulated. The first number in brackets is the e.s.d., and the second is the maximum deviation from the mean value. b. The chemical identity of the donor atom or ligand. c. The value of the (OO)O-Nb-C(OO) angle is 75.7(5,2,5)°. d. The values of Hg-Nb-Hg angles; cp-Nb-Hg = 104.0(0,12,9)°; cp(centroid)-Nb-cp(centroid) = 136.0°. e. The values of Ni-Nb-C(OO) angles; H-Nb-C(OO) and M-Nb-Cp angles; Cp-Nb-C(OO) bridge = 116.3(1)°. f. The values of the Ni-Nb-H and Ni-Nb-C(OO) angles; H-Nb-C(OO) = 97.1°. g. The values of the H(1)-Nb(1)-C(5)(OO) and H(2)-Nb(2)-C(6)(OO) angles. h. The value of the H-Nb-CO angle is 102.8°. i. The values of the Re-Nb-H and Re-Nb-C(OO) angles; H-Nb-C(OO) = 100.0(1.1)°; Re-Nb-C(cp) = 76.3(1)-137.8(1)°; (OO)O-Nb-C(cp) = 75.8(1)-133.0(2)°; H-Nb-C(cp) = 73.4(10)-129.7(10)°; (cp)O-Nb-C(cp) = 34.0(1)-57.6(1)°; cp(centroid)-Nb-cp(centroid) = 136.3°. j. At -35°C. k. These are independent molecules. l. The values of Os-Nb-C(OO) bridge and Os-Nb-C(OO); (OO)O-Nb-C(OO) bridge = 112.6(1)°; Os-Nb-C(cp) = 79.7(1)-139.6(1)°; (OO) bridge O-Nb-C(cp) = 71.0(1)-128.4(2)°; (OO)O-Nb-C(cp) = 75.5(2)-133.1(2)°; (cp)O-Nb-C(cp) = 32.9(1)-56.7(1)°. m. S-Nb-S = 97.9(3,1)°; cp(centroid)-Nb-cp(centroid) = 129.6(0,3)°. n. (CS₂)S-Nb-S = 37(2)°; S-Nb-C($\eta\text{-C}_6\text{H}_5$) = 73(4)°.

There is a relationship between the Nb-L distances and the Nb-H-M bridge angle. As the angle opens, the Nb-C (CO) distance decreases and both the Nb-H and the Nb-M distances increase. For example, the values for the Nb-C (CO), Nb-H, and Nb-M distances, and the Nb-H-M angle in $(\eta^5\text{-cp})_2\text{Nb}(\text{CO})(\mu\text{-H})\text{Zn}(\text{BH}_4)_2$ (ref.36) are 205.8(4)pm, 174.6pm, 282.9pm, and 107°; in $(\eta^5\text{-cp})_2\text{Nb}(\text{CO})(\mu\text{-H})(\eta^5\text{-cp})\text{Mn}(\text{CO})_3$ (ref.38) are 203.5(10)pm, 198(8)pm, 333.0(2)pm and 141(5)°; and in $(\eta^5\text{-cp})_2\text{Nb}(\text{CO})(\mu\text{-H})(\eta^5\text{-CO})\text{V}(\text{CO})_3$ (ref.39) are 202.4(15)pm, 206(18)pm 372.5(4)pm and 173(8)° respectively (Table 3).

The white crystalline compound $(\eta^5\text{-C}_5\text{H}_4\text{Me})_2\text{Nb}(\text{CH}_2\text{SiMe}_3)(\eta^5\text{-CO}_2)$ has been prepared and the x-ray structural analysis reported (ref.41). In this compound the Nb atom is combined with the SiMe₃ moiety through the carbon atom of the CH₂ group. The coordination sphere around the Nb atom is built up of two η^5 -bonded C₅H₄Me rings, and the CO₂ ligand which chelates to the Nb atom (Nb-O = 217.3(4)pm, and Nb-C = 214.4(7)pm, Table 3).

In two examples from Table 2, $[(\eta^5\text{-cp})_2\text{Nb}(\text{CO})(\text{H})]_2\text{Mo}(\text{CO})_4$ (ref.35), and $[(\eta^5\text{-cp})_2\text{Nb}(\text{SMe})_2]_2\text{Ni}]^{2+}$ (ref.43), two cp₂Nb(CO)H molecules are joined to the Mo(CO)₄ group via the hydride bridges in the former, and the NiS₄ group is bonded by planar methanethiolato bridges to two cp₂Nb moieties in the latter, so that the Nb-Ni-Nb system is linear. The mean Nb-Ni distance of 277.0(5)pm is one of the shortest found between Nb and a d-block element (Table 3). The other bond distances are not unusual.

By contrast, no metal-metal interaction has been found in $(\eta\text{-C}_4\text{H}_9)(\eta^5\text{-cp})_2\text{Nb}(\mu\text{-CS}_2)\text{W}(\text{CO})_5$ (ref.44). The Nb($\mu\text{-CS}_2$)-W unit is almost planar, the CS₂ group is η^2 -bonded to the Nb through a C=S linkage (Nb-S = 252(3)pm and Nb-C = 211(8)pm), and σ -bonded to W through the other S atom (W-S = 256(3)pm, Table 3). It is interesting to note that the Nb-S and the Nb-C distances are quite comparable to those found in $(\eta^5\text{-cp})_2\text{Nb}(\text{CS}_2)(\text{CH}_3)$ (ref.22) and $(\eta^5\text{-cp})_2\text{Nb}(\text{CS}_2)(\text{allyl})$ (ref.23) where the CS₂ group is bonded to the niobium atoms in the same manner (Table 2) as in the above examples.

The mean Nb-C (cp) distance of 239.2pm for the heterobinuclear compounds (Table 3) is only about 1.1pm shorter than the corresponding distance in the mononuclear biscyclopentadienyl compounds (Table 2), but shorter by 3.3pm than that of the monocyclopentadienyl derivatives (Table 1). Similarly, the Nb-C (CO) mean length of 205.3pm (Table 3) is somewhat shorter than 206.0pm (Table 1).

4. HOMOLIGONUCLEAR COMPOUNDS

A. Binuclear Compounds

In the homobinuclear derivatives there are four main types of bridging between the two niobium atoms. In $[(\eta^5\text{-cp})\text{Nb}(\text{CO})\text{L}]_2$, where L = Ph₂C₂ (ref.47), and L = (CH₃COOC)₂ (ref.48), two ($\eta^5\text{-cp}$)NbCO moieties are bridged

$(\eta^5:\eta^5\text{-C}_5\text{H}_4\text{C}_5\text{H}_4)(\eta^5\text{-cp})_2\text{Nb}_2(\mu\text{-NC}_6\text{H}_4\text{OCH}_3)$ and its cationic form (ref.49), each Nb atom is coordinated to two cp ligands to form two clino-sandwich halves linked by two nitrene ligands. While the Nb-N(bridge) distances are almost equal in both compounds (Table 4), the Nb-C distances are somewhat longer in the former than in the latter, while the Nb-Nb distances vary in the opposite sense. In the cationic form the Nb-Nb bond distance of 292.1(1)pm is about 8.7pm longer than that in the neutral form. This observation correlates well with the observed Nb-N-Nb bridge angle which is about 3° larger in the former than the latter.

The most unusual type of bridging is that involving C_5H_4 ligands which has been reported in $[(\text{cp})\text{C}_5\text{H}_4\text{NbH}]_2$ (ref.52). Two $(\text{cp})\text{C}_5\text{H}_4\text{NbH}$ moieties are linked by two C_5H_4 ligands through one carbon atom of each. Interestingly, the Nb-C (C_5H_4) bridge distance of 223(2)pm (mean value) is about 14pm shorter than that of the non-bridged value of 237(2)pm. However, both are shorter than that of Nb-C (cp) (Table 4). There are three crystallographically unique molecules which differ only slightly in bond lengths and angles.

There are a few examples in which one atom serves as the bridge between

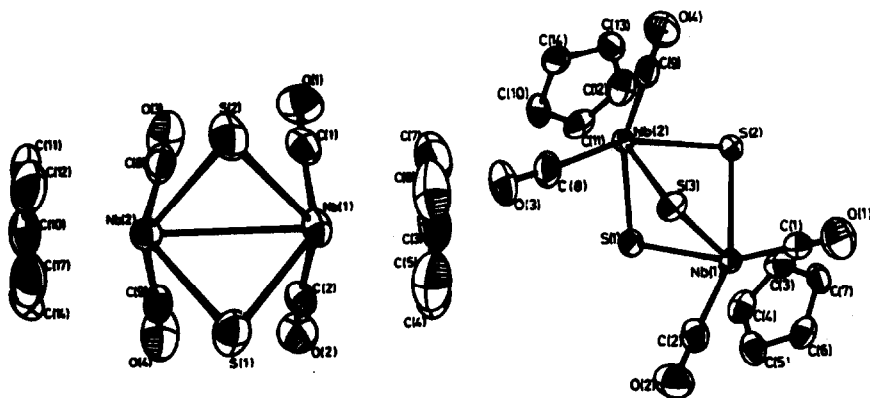

Figure. 10. Crystal structure of $[(\eta^5\text{-cp})\text{Nb}(\text{CO})_2]_2(\mu\text{-S})_3$.

Reproduced with permission from J. Organomet. Chem. (ref.54).

two niobium atoms. In $\{[\eta^5\text{-C}_5\text{H}_4\text{CH}_3\text{NbCl}_3(\text{H}_2\text{O})]_2(\mu\text{-O})\}$ (ref.8) and $\{[(\eta^5\text{-cp})_2\text{NbCl}_2]_2\text{O}\}^{2+}$ (ref.19), the bridge is an oxygen atom; in $\{(\eta^5\text{-cp})_2\text{Nb}(\text{CO})(\mu\text{-H}).(\eta^5\text{-cp})\text{Nb}(\text{CO})_3\}$ (ref.39) it is a hydrogen atom; and in $(\eta^5:\eta^5\text{-C}_5\text{H}_4\text{C}_5\text{H}_4)(\text{cp})_2\text{Nb}_2(\mu\text{-Cl})$ (ref.50) it is a chlorine atom. In this series of monoatomic bridged compounds there is a tendency for elongation of the Nb-Nb distance as the Nb-L-Nb angle opens (Table 4), which is very similar to the diatomic bridged derivatives. It is also noted that the Nb-C (cp) distance elongates with the opening of the Nb-L-Nb angle. For example, the Nb-C (cp) mean value and the Nb-L-Nb angle in the last compound (ref.50) are 236(4)pm and 79.6° respectively, and in the first compound (ref.8) are 243.7(4)pm and 171.8(1)° respectively.

A possible fifth type, for which there is to date only one example consists of two $(\eta^5\text{-cp})\text{Nb}(\text{CO})_2$ moieties (Figure 10) linked by three sulphur atoms. Here the metal-metal distance of 355.5(1)pm is longer than those found in the two sulphur bridge binuclear compounds, and the Nb-S-Nb angles and the Nb-S distances follow the expected trend.

B. Trinuclear Compounds

Structural data are summarized in Table 4 for the trinuclear compounds. An X-ray investigation of $(\eta^5\text{-cp})_3\text{Nb}_3(\text{CO})_7$ (ref.56) reveals that the compound consists of a trinuclear cluster with one of the seven CO ligands acting as a $\eta^2(\mu_3\text{-C},\mu_2\text{-O})$ bridge symmetrically facing a nearly equilateral triangle of niobium atoms (Figure 11). The metal-metal separations range between 304.4 and 332.0(2)pm, which are quite comparable to the Nb-Nb bond lengths found in the binuclear derivatives (Table 4). It is interesting to note that the mean Nb-C (cp) and Nb-C (CO) bond distances of 239.3 and 206.3pm respectively are very similar to those found in the heterobinuclear derivatives (239.2 and 205.3pm respectively). In another trinuclear compound, $\{[(\eta^5\text{-cp})\text{Nb}(\mu_2\text{-OOCH})(\mu_2\text{-OH})]_3(\mu_3\text{-O})\}\text{H}$ (ref.57), the bidentate formate and hydroxyl groups, together with the tridentate bridging oxygen atom, link three niobium atoms located at the apices of an almost equilateral triangle with Nb.....Nb contacts of 313.6(4)pm (2x) and 314.9(4)pm. Each pair of niobium atoms are linked by two bridging ligands, formate and hydroxyl, and in addition there is an oxygen atom attached to all three metal atoms. Each niobium also carries a π -bonded cp ligand with a Nb-C (cp) distance of 247(3)pm (mean value). All three of the bridges are very similar in geometry, and the Nb-O-Nb angle is close to tetrahedral (Table 4). The mean Nb-O (triple-bridge) distance of 204(4)pm is about 14.0pm longer than the mean of the double-bridge species, 190pm (Table 4), as would be expected.

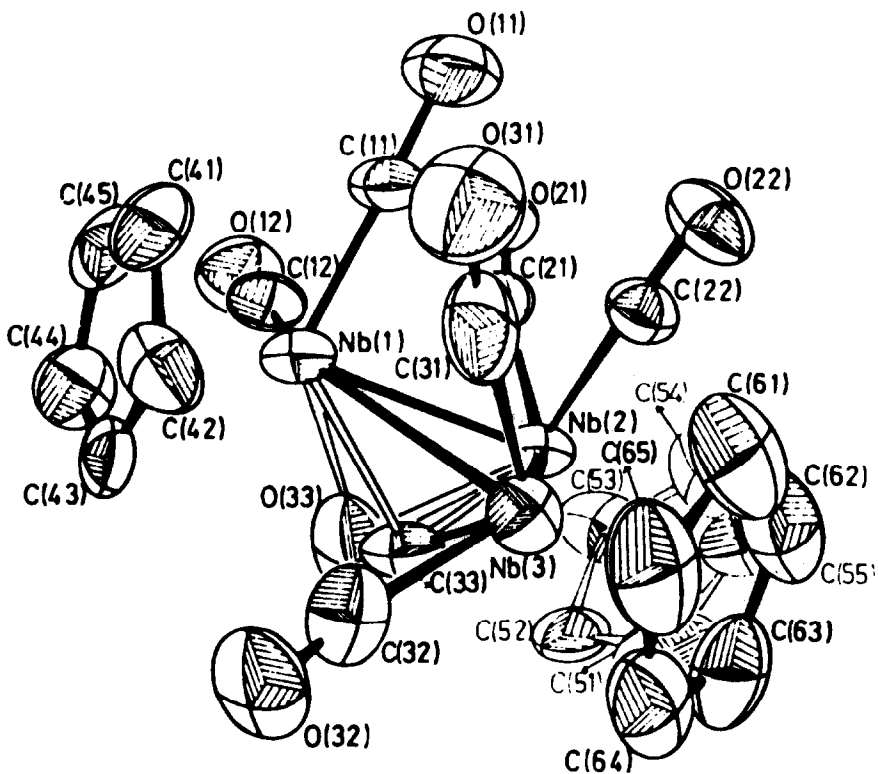

Figure. 11. Molecular structure of $(\eta^5\text{-cp})_3\text{Nb}_3(\text{CO})_7$.
 Reproduced with permission from J. Am. Chem. Soc. (ref.56).

Internuclear contacts of 333.4(6)pm between niobium atoms have been found in another trinuclear niobium cluster, $[(\text{Me}_6\text{C}_6)_3\text{Nb}_3\text{Cl}_6]\text{Cl}$ (ref.58), Table 4. Each pair of niobium atoms are bridged by two chlorine atoms, and the two Nb_3 triangles are staggered with respect to each other. Each niobium atom also carries a π -bonded Me_6C_6 unit. There are three crystallographically independent Nb-C distances, 234(3)pm, 253(3)pm, and 258(3)pm, respectively. The mean Nb-Cl bridge distance of 247.7(2)pm is shorter than the corresponding distances in the binuclear complex $(\eta^5:\eta^5\text{C}_5\text{H}_4\text{C}_5\text{H}_4)(\text{cp})_2\text{Nb}_2(\mu\text{-Cl})$ (ref.50) of 256.5(4)pm.

TABLE 4. STRUCTURAL DATA FOR HOMOLIGONUCLEAR NIOBIUM ORGANOMETALLIC COMPOUNDS^a

| COMPOUNDS | CRYSTAL SPACE CLASS | Z | a (pm) b (pm) c (pm) | α (°) β (°) γ (°) | M-L (pm) | M-M (pm) | L'-M-L M-L-M' (°) | REF. |
|--|-----------------------------|--------|--|---|---|----------------------------------|---|----------|
| $[(\eta^5\text{-cp})\text{Nb}(\text{CO})(\text{Ph})_2\text{C}_2]_2$ | tr $P\bar{1}$ | 1 | 1043(2) 960(2) 912(2) | 110.4(5) 71.1(5) 114.1(5) | 0c ^b 208(2) C 211(2,1) C 240(2,2) | 274.2(5) | c | 45-47 |
| $[(\eta^5\text{-cp})\text{Nb}(\text{CO})(\text{Ph})_2\text{C}_2]_2 \cdot \text{C}_6\text{H}_6$ | tr $P\bar{1}$ | 1 | 1191 932 859 | 109.3 94.7 90.5 | (cp)C 245(2,6) | | | 45 |
| $[(\eta^5\text{-cp})\text{Nb}(\text{CO})(\text{CH}_3 \cdot \text{COOC})_2]_2$ | tr $P\bar{1}$ (P1) | 1 | 981(2) 853(2) 826(2) | 99.5(5) 105.9(5) 107.5(5) | 0C 211(2) C 209(2,1) C 235(2,0) | 273.2(5) | d 108(1) ^c | 48 |
| $(\eta^5\text{-}\pi^5\text{-C}_9\text{H}_7\text{C}_3\text{H}_4)(\text{cp})_2 \cdot \text{Nb}_2(\mu\text{-NC}_6\text{H}_4\text{OCH}_3)$ | m $P2_1/a$ | 2 | 799.6(1) 1755.8(3) 966.6(1) | 96.21(1) | (cp)C 237(2,2) N _{br} 204(3) C 248(2,4) | 283.4(5) | 88(1); 95(1) 88(1,1) | 49 |
| $[(\eta^5\text{-}\pi^5\text{-C}_9\text{H}_7\text{C}_3\text{H}_4)(\text{cp})_2 \cdot \text{Nb}_2(\mu\text{-NC}_6\text{H}_4\text{OCH}_3) \cdot \text{BF}_4 \cdot \text{CH}_3\text{NO}_2$ $(\eta^5\text{-}\pi^5\text{-C}_9\text{H}_7\text{C}_3\text{H}_4)(\text{cp})_2 \cdot \text{Nb}_2(\mu\text{-Ct})$ | trg R3 rh $P2_1^+2_12_1$ | 6 4 | 1761.8(5) 834.8(4) 917.3(4) 2161(1) | 74.98(2) | N _{br} 204.2(6,1,3) C 245.0(7,21) (cp)C 245.7(7,12) C _{br} 256.5(4,8) C 237(2,10) (cp)C 236(4,6) | 292.1(1) 292.1(1) 327.0(3) | 87.5(2,2) 91.3(2,0) not given 79.2 | 49 50 |

TABLE 4. (Continued - 2)

| COMPOUNDS | CRYSTAL SPACE CLASS | Z | a (Å) b (Å) c (Å) | α (°) β (°) γ (°) | M-L (Å) (Å) | M-M (Å) (Å) | L'-M-L M-L-M' (°) | REF. |
|--|--|----|-------------------------|---|---|----------------|---------------------------------|------|
| [(η^5 -cp)(C ₅ H ₄)NH] ₂ e | P2 ₁ 2 ₁ 2 ₁ 12 | 12 | 1538.4(4) | | H 171(18,4) | 310.5(3,10) | e | 51 |
| | | | 2448.7(5) | | (H ₄ C ₅)C _{br} 223(2,2) | | 86.5(2,1,2) | 52 |
| [(η^5 -cp) ₂ NbS] ₂ | P2 ₁ /c | 2 | 1287.9(3) | | (H ₄ C ₅)C 237(2,12) (cp)C 240(2,5) | 323.43(8) | 96.49(6) 83.51(5) | 53 |
| | | | 1326.0(10) | | S _{br} 242.8(2,1) (cp)C 245.2(7,36) | | | |
| [[(η^5 -cp)Nb(CO) ₂] ₂ · ·(μ-S) ₂ (C ₂ H ₅ O)· ·(C ₂ H ₁₂) | P2 ₁ /c | 4 | 872.9(2) | | S _{br} 255.7(1,6) (OC)C 208.2(5,9) | 314.3(1) | 73.7(0); 87.3(2) 75.8(0,2) | 54 |
| | | | 1107.6(3) | | (cp)C not given | | | |
| [[(η^5 -cp)Nb(CO) ₂] ₂ · ·(μ-SMe) ₂] ₂ · ·(C ₂ H ₅ O)(C ₂ H ₁₂) | C2 | 8 | 1696.1(7) | | S _{br} 256.2(16,17) (OC)C 204(5,8) | 316.4(9) | 70.9(5); 84.3(19) 76.3(4,2) | 54 |
| | | | 892.6(5) | | (cp)C not given | | | |
| [[(η^5 -cp)Nb(CO) ₂] ₂ · ·(μ-S) ₃ (C ₂ H ₅ O)· ·(C ₂ H ₁₂) | P2 ₁ /C | 4 | 2198.5(3) | | (cp)C not given | 314.3(1) | 73.7(0); 87.3(2) 75.8(0,2) | 54 |
| | | | 872.9(2) | | S _{br} 255.7(1,6) (OC)C 208.2(5,9) | | | |
| [[(η^5 -cp)Nb(CO) ₂] ₂ · ·(μ-SMe) ₂] ₂ (C ₂ H ₅ O) | C2 | 8 | 1696.1(7) | | (cp)C not given | 316.4(9) | 70.9(5); 84.3(19) 76.3(4,2) | 54 |
| | | | 892.6(5) | | S _{br} 256.2(16,17) (OC)C 204(5,8) | | | |
| [[(η^5 -cp)Nb(CO) ₂] ₂ · ·(μ-S) ₃ (C ₂ H ₅ O)· ·(C ₂ H ₁₂) | C2/c | 8 | 2198.5(3) | | (cp)C not given | 355.5(1) | 77.3(7); 87.8(4) 86.3(1,3,3) | 54 |
| | | | 2624.4(9) | | S _{br} 260.0(3,80) (OC)C 210.0(12,15) | | | |
| [(η^5 -cp) ₃ (C ₂ H ₅ O)· ·(C ₂ H ₁₂) | C2/c | 8 | 1012.0(5) | | (OC)C 210.0(12,15) (cp)C not given | | | |
| | | | 1520.4(9) | | (cp)C not given | | | |

TABLE 4. (Continued - 3)

| COMPOUNDS | CRYSTAL SPACE CLASS | Z | a (Å) b (Å) c (Å) | α (°) β (°) γ (°) | M-L (Å) | M-M (Å) | L ¹ -M-L M-L-M ¹ (°) | REF. |
|--|---------------------|---|-------------------------|---|-----------------------------------|-----------------------|---|-----------|
| [[$(\eta^5\text{-cp})_2\text{Nb}(\text{CO})$]. .($\mu\text{-H})(\eta^5\text{-cp})\text{Nb}$.(CO) ₃] _f | $P\bar{1}$ | 4 | 1115.2(4) | 67.60(3) | S _{br} 188(25,2) | 373.8(3) | 71.7(7,2,2); 106.5(7) | 39 |
| | | | 1341.9(6) | 72.05(2) | (OC) 204.2(16,26) | 167(12) | | |
| | | | 1484.0(4) | 69.10(3) | (cp)C 239.8(17,69) | | | |
| | | | | | H _{br} 1.88(16,2) | 73.0(8,1,4); 109.5(6) | | |
| | | | | | (OC) 204.2(18,26) | 164(9) | | |
| | | | | | (cp)C 240.2(19,84) | | | |
| [[$(\eta^5\text{-C}_5\text{H}_4\text{CH}_3)\text{Nb}$. .(CO) ₃ (H ₂ O)] ₂ ($\mu\text{-O}$) | $P\bar{1}$ | 2 | 735.2(1) | 75.12(1) | O _{br} 191.3(2,13) | | 76.5(1,6)g | 7,8 |
| | | | 1109.4(2) | 75.50(1) | (H ₂ O)O 218.9(3,3) | 171.8(1) | | |
| | | | 1297.3(1) | 86.28(1) | C ₂ 245.7(1,31) | | | |
| | | | | | (cp)C 243.7(4,44) | | | |
| | | | | | O _{br} 188(1) | 96.2(9) | 19 | |
| | | | | | C ₂ 237.0(4) | 169.3(8) | | |
| | | | | | (cp)C 242(1,4) | | | |
| [($\eta^5\text{-cp}$) ₃ Nb ₃ (CO) ₇ | $P2_1/c$ | 4 | 1717.0(8) | 90.0 | (OC)O _{br} 215.6(16,190) | 304.4(2) | 82.2(7,8); 93.1(9) | 55, 56 |
| | | | 775.2(4) | 117.37(3) | (OO)O _{br} 222.5(10,13) | 318.1(2) | h | |
| | | | 1876.0(8) | 90.0 | (OC)C 206.3(19,54) | 332.0(2) | | |
| | | | | | (cp)C 239.3(22,66) | | | |
| | | | | | O _{br} 204(2,2) | 313.6(4) | 77-153(1) | |
| | | | | | (HO)O _{br} 197(2,4) | 314.9(4) | 100(1); 106(1) | |
| | | | | | (OOCH)O _{br} 218(2,4) | | | |
| | | | | | (cp)C 247(3,6) | | | |
| [[$(\eta^5\text{-cp})\text{Nb}(\mu_2\text{-OOCCH})$. .($\mu_2\text{-OH})$] ₃ ($\mu_3\text{-O}$)] _H | $R2/m$ | 4 | 1315.0(5) | | | | | 57 |
| | | | 890.1(5) | | | | | |
| | | | 1746.7(5) | 102.7(2) | | | | |

TABLE 4. (Continued - 4)

| COMPOUNDS | CRYSTAL SPACE CLASS | Z | a (Å) b (Å) c (Å) | α (°) β (°) γ (°) | M-L (Å) M-M (Å) | L'-M-L M-L-M' (°) | REF. |
|---|---------------------|---|-------------------------------------|---|--|--|------|
| $[(\text{Me}_5\text{C}_6)_3\text{Nb}_3\text{O}_6]\text{Cl}_2$ | hx | 1 | 1225.71(13) - | | O_{br} 247.7(9,22) C 248(3,14) | 80.3(4,4.1); 134.4(4) 84.4(3) | 58 |
| $[\text{NbCl}_3(\text{Ph}_2\text{C}_2)_4]$ | tr | 1 | 1074.3(4) 1389.5(5) 1299.4(6) | 104.28(3) 107.99(4) 108.72(3) | O_{br} 276.1(5,184) ⁱ O_{br} 252.3(5,65) ^j O_{br} 232.3(5,6) C 205.2(19,16) | 79.9(2,8.7); 159.6(2) ^k 102.2(2,9.9) | 59 |
| $[(\eta^5\text{-cp})_2(\text{OO})\text{Nb}_2 \cdot (\eta\text{-H})][\text{M}(\text{CO})_5]^-$ | or | 4 | 1358.3(3) 1556.5(3) 1262.2(2) | | H_{br} 193(6,3) (OC)C 204.1(7,15) (cp)C not given | 377.39(8) not given | 60 |

a. Where more than one chemically equivalent distance or angle is present, the mean value is tabulated. The first number in brackets is the e.s.d., and the second is the maximum deviation from the mean value.
b. The chemical identity of the coordinating atom or ligand. c. Nb'-Nb-cp(centroid) = 108(1)°. e. There are three crystallographically unique binuclear molecules. The Nb'-Nb-C angles are 45.8° and 47.7(1)° (mean). f. There are two crystallographically unique binuclear molecules. g. The value of $\text{O}_{\text{br}}\text{-Nb'-Nb}' = 60.00(5,4.3)$ °; Nb'-Nb- $\text{O}_{\text{br}}(\text{OO}) = 42.0(4,6.2)$ °; Nb'-Nb- $\text{O}_{\text{br}}(\text{OO}) = 54.7(2,16.8)$ °; Nb'-Nb-C(10) = 68.8-143.2(6)°. i. The value of the triple bridge distance. j. The value of the double bridge distance. k. The values of $\text{C}_{\text{br}}\text{-Nb-C}_{\text{br}}$ angles; $\text{C}_{\text{br}}\text{-Nb-C}_{\text{br}} = 86.1(2,7.5)$ ° and 158.8(2,1.2)°; $\text{O}_{\text{br}}\text{-Nb-C} = 87.4(5,9.9)$ °, 111.5(5,5.4)° and 161.1(5,11.1)°; $\text{C}_{\text{br}}\text{-Nb-C} = 90.5(5,1.7)$ ° and 112.6(3,2.1)°; $\text{C-Nb-C} = 37.6(7)$ °.

C. Tetranuclear Compounds

To our knowledge, the only example of a tetranuclear niobium organometallic complex is $[(\text{Ph}_2\text{C}_2)\text{NbCl}_3]_4$ (ref.59). The crystal structure (Figure 12) shows it to be a centrosymmetric tetramer, which may be regarded as a distorted double hexahedron with two corners missing. Association is effected by two triple-bridge chlorine atoms ($\text{Nb}-\text{Cl} = 252.3, 281.6, \text{ and } 294.5(5)\text{pm}$), and double-bridge chlorine atoms ($\text{Nb}-\text{Cl} = 245.8, 250.9, 254.4, \text{ and } 257.9\text{pm}$). In addition, each Nb atom carries a diphenylacetylene ligand bonded through two carbon atoms. The remaining one position on Nb(1), Nb(1)', and two on Nb(2), Nb(2)' are occupied by terminal chlorine atoms ($\text{Nb}-\text{Cl} = 232.9, 231.7 \text{ and } 232.4(5)\text{pm}$). Thus each metal atom achieves a coordination number of seven. The mean Nb-Cl

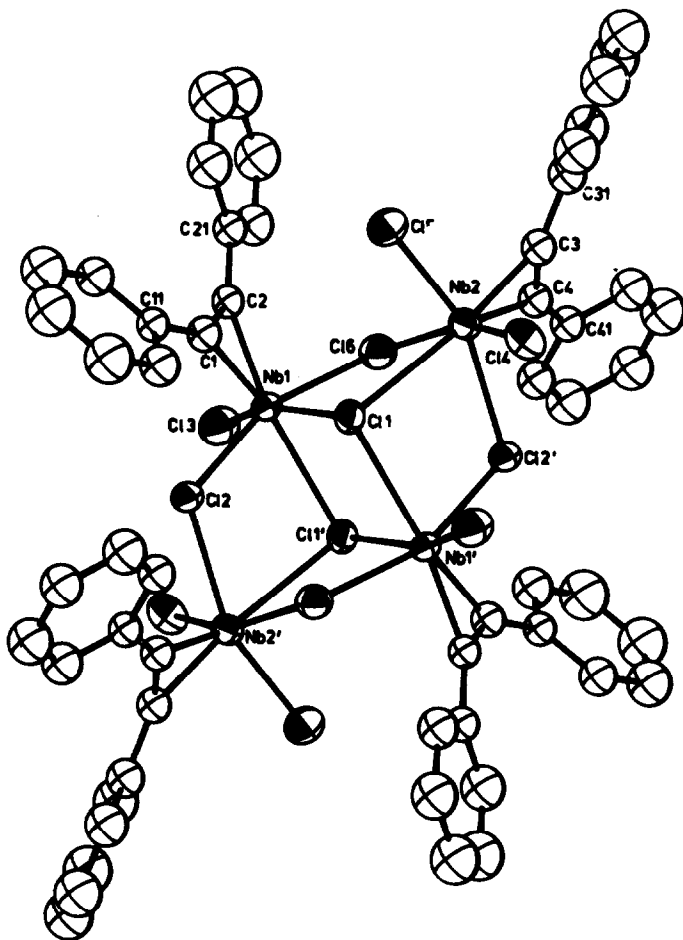

Figure. 12. Molecular structure of $[\text{NbCl}_3(\text{Ph}_2\text{C}_2)]_4$.

Reproduced with permission from Z. Anorg. Allg. Chem. (ref.59).

distance lengthens as the chlorine coordination number increases, being 232.3(5)pm for unidentate, 252.3(5)pm for bidentate and 276.1(5)pm for tridentate. This is the trend which would be expected, and the same effect is observed for the Nb-C (Ph₂C₂) bond distances. The mean value of the Nb-Cl (unidentate) bond length decreases with increasing degree of aggregation, i.e.: 247.8pm (mononuclear), 241.4pm (binuclear), 232.3pm (tetranuclear). However, for the Nb-Cl (bidentate) bond length the order differs such that binuclear (256.5pm) > tetranuclear (252.3pm) > trinuclear (247.7pm). This may reflect the effects of large differences in the values of the Nb-Cl-Nb angles which are 79.2, 110.3, and 84.4° respectively in the bidentate case.

5. CONCLUSIONS

The data collected in this review represent the more than sixty organometallic compounds of niobium for which structural data is available at the end of 1984. The structures can be classified as mostly mono- and binuclear, with three examples of trinuclear and one example of tetranuclear. This is in contrast to the coordination compounds of niobium where a greater tendency to form cluster or chain structures has been observed (ref.3).

The electronic configuration of niobium in these derivatives shows a distinct trend of $d^5 \gg d^2 > d^1 \sim d^0$, which again, by contrast, is the reverse to that observed for the coordination complexes (ref.3).

There are a few examples, (η^5 -cp)Nb(CS₂)(allyl) (ref.23); (η^5 -cp)₂Nb(CH₂Ph)₂ (ref.25); (η^5 -cp)₂Nb(CO)(μ -H)(η^5 -cp)V(CO)₃ (ref.39) and $\{[(\eta^5$ -cp)₂Nb(CO)](μ -H)(η^5 -cp)Nb(CO)₃\} (ref.39), in which two crystallographically independent molecules are present, differing by their degrees of distortion. There is even one example, [$(\eta^5$ -cp)(C₅H₄)NbH]₂ (ref.52) in which three such molecules are present. Such types of distortion have also been found in niobium coordination compounds (ref.3), and also in other metal complexes, especially copper(II). The coexistence of two (or three) species of the same coordination number of the central atom, but with different degrees of distortion within the same crystal, is typical of the general class of distortion isomers (ref.61).

A summary of the structural data for organometallic niobium compounds is given in Table 5. Inspection of the data reveals that:

- (a) In general, the mean Nb-L bond distance in mononuclear compounds with one cp ligand is somewhat longer than those with two cp ligands.
- (b) The Nb-L distances in homooligonuclear compounds are somewhat longer than those of the heteronuclear compounds.

TABLE 5. SUMMARY OF THE NIOBIUM-ATOM(LIGAND) BOND DISTANCES (pm)^a

| COORD. ATOM (LIGAND) | MONONUCLEAR | | BIS-cp | HETERONUCLEAR | HOMONUCLEAR |
|------------------------------------|----------------------|----------------------------------|--------------------|-----------------------------------|--|
| | MONO-cp | | | | |
| C(cp) | 236.4 - 248.0(242.5) | 234.0-246.0(240.3) | 234.0-246.0(240.3) | 233.0-251.0(239.2) | 232.0-248.8(242.2) (234.2-250.0(241.2)) ^b |
| C(Fp ₂ C ₂) | 216.0-229(220.6) | 225-232(229) | | | 211-240(225) (221-206.2(205)) ^c |
| C(OO) | 200-211.5(206.0) | 202-204(203) | 202-204(203) | 202.3-212.5(205.3) | 196-211.5(206.5) (202.0-211.7(206.3)) ^b |
| C(OO bridge) | | | | 222.0-278.1(251.6) | (196.6-227.8(215.7)) ^b |
| O(OO bridge) | | | | 226 | (221.2-223.8(222.5)) ^b |
| C ^d | 210-251(231) | 227.7-234.6(230.6) | | | 209-235(222) (234-258(248)) ^c (221-225(223)) ^e |
| H | | 150-176(164) 200 ^f | | (174.6-206.0(187.3)) ^e | (167-190(179)) ^e |

TABLE 5. (Continued - 2)

| COORD. ATOM (LIGAND) | MONONUCLEAR | | HETERONUCLEAR | HOMONUCLEAR |
|-------------------------|--------------------|--------------------------------------|-------------------------------|---|
| | MONO-CP | BIS-CP | | |
| N | 238 | | | (204-204.2(204.0)) ^f |
| O | | 163 (197-200(198.5)) ^h | 217.3 ^g | 188.0-192.6(189.7) 204 ⁱ |
| Cl | 246.3-250.5(248.1) | 246.4-248.3 | | 232.0-237.0(234.5) (231.7-232.9(232.3)) ^c (255.7-257.0(256.5)) ^f (246.6-249.9(247.7)) ^{b,e} (245.8-257.9(252.3)) ^{c,e} (252.3-294.5(276.1)) ^{c,i} |
| S | | 243.2-260.2(251.2) | (246.8-252(249)) ^f | (242.8-264.8(253.7)) ^e |

a. The mean value is in parenthesis. b. The values for trinuclear. c. The values for tetranuclear. d. Excluding all ligands listed above, and also $\eta^5\text{-C}_5\text{H}_5$, C_6H_6 . e. The values for a bridge atom (ligand). f. The value for $\text{Nb}-(\text{Nb}_4)$ distance. g. The value for $\text{Nb}-\text{O}(\text{O}_2)$ bridge distance. h. The values of bidentate O_2 to the same Nb atom. i. The value for the triple bridging atom.

(c) The Nb-L distances usually increases with an increase in coordination number of both the central atom and the donor atom.

(d) The mean Nb-C bond distance, when the C donor atom is a part of a bi- or multi-dentate ligand, increases in the order: Ph_2C_2 (225pm) < C_2H_4 (229pm) < Ph_4H_4 (238pm) < cp (242pm) < $\text{C}_5\text{H}_4\text{C}_5\text{H}_4$ (243pm) < Me_6C_6 (248pm).

(e) The mean Nb-C bond distance, when the carbon donor atom is a part of a unidentate ligand, increases in the order: CO (205pm) < CS_2 (222pm) < PhCH_2 (227pm) < C_2H_5 (232pm) < CH_3 (234pm).

(f) In mononuclear biscyclopentadienyl compounds where an O_2 , S_2 or CS_2 group is bonded to Nb via two atoms, the Nb-L distance follows the same order as the van der Waals radii (r) of the coordinate atoms, ie: O_2 (r = 1.52pm), Nb-O = 200 and 197pm; CS_2 , C (r = 170pm), Nb-C = 222.4pm (mean), S (r = 180pm), Nb-S = 250.9pm; S_2 , Nb-S = 252.2pm (mean). The asymmetric side-on bonding of the O_2 , S_2 , or CS_2 ligands to a niobium atom causes a bond length increase in the order: 3pm for O_2 ; 7.7pm for S_2 ; 28.5pm for CS_2 . The values of Nb-O, 198.5pm (mean), 3pm difference between the two Nb-O distances, and O-Nb-O angle of 43.6° which are found in peroxo-organometallics are within the range of those found for the coordinate complexes (ref.3), 196.1-206.6pm (200.1pm mean), 0.1-7.3pm (1.2pm mean), and $43.0-44.3$ (43.8 mean), respectively.

In heterobinuclear organometallics, the Nb-M distance increases with increasing Nb-L-M angle, and at the same time the Nb-L(bridge) distance also increases. While the Nb-C (cp) distance remains constant (238pm), the Nb-C (CO) distance decreases as the Nb-M distance increases. The Nb-M distance is dependent on M, so that for similar types of structure the metal-metal bond length increases in the order $\text{Zn} < \text{Co} < \text{Ni} < \text{Fe} < \text{Mn} < \text{V}$.

The shortest Nb-Nb distance of 273.2(5)pm is found in the binuclear niobium organometallics, being about 3.6pm longer than that found in the coordination compounds (ref.3). Usually, the Nb-Nb distance increases with degree of aggregation, as does the variation between comparable organometallic and inorganic coordination oligonuclear derivatives. For example, the shortest Nb-Nb distance of 304.4(2)pm in trinuclear organometallic clusters is about 17pm longer than that in the coordination compounds. Listed below are some factors which appear to influence the Nb-Nb bond distance.

(i) Oxidation state of the central atom: it was found (ref.3) that the oxidation number three gives the highest Nb-Nb bond order.

(ii) The number of bridging atoms: from the examples of one, two and three bridging atoms it was observed that two gives the most favourable Nb-Nb bond.

(iii) The Nb-L-Nb angle: usually the Nb-Nb bond distance increases as the angle opens.

(iv) Steric effects of the coordinate ligands: increasing steric hindrance of the ligand elongates the Nb-Nb bond, the effect being more noticeable in the organometallics than in the coordination complexes.

This survey together with the corresponding survey of the coordination compounds (ref.3), illustrates a rich variety of niobium complexes for which the structures have been defined by x-ray crystallography or related techniques in the gas phase. Despite the variability of the compounds, many systematic trends have been observed and outlined here. From these trends, directions for further inquiry are more apparent in this and related areas.

ACKNOWLEDGEMENTS

The authors wish to thank those who gave permission for use of their published figures, the Chemical Faculty of the Slovak Technical University for their cooperation in allowing M.M. to participate, and Carol V. Francis for assistance in formatting this presentation.

6. REFERENCES

1. I. Omae, *Angew. Chem. Int. Ed. Engl.*, 21 (1982) 889-902; *Coord. Chem. Rev.*, 42 (1982) 31-54; *ibid.* 51 (1983) 1-39.
2. R.C. Kerber, *J. Organomet. Chem.*, 254 (1983) 131-142.
3. C.E. Holloway and M. Melnik, submitted to *J. Chem. Soc. Reviews*.
4. W.A. Herrmann, W. Kalcher, H. Biersack, I. Bernal, and M. Creswick, *Chem. Ber.*, 114 (1981) 3558-3571.
5. H.C. Aspinall, M.M. Robert, and S.J. Lippard, *Inorg. Chem.*, 23 (1984) 1782-1784.
6. N.I. Kirillova, A.I. Gusev, A.A. Pasynskii, and Yu.T. Struchkov, *Zh. Strukt. Khim.*, 15 (1974) 288-293.
7. J.C. Daran, K. Prout, A. De Cian, M.L.H. Green, and N. Sigantoria, *J. Organomet. Chem.*, 136 (1977) C4-C6.
8. K. Prout and J.C. Daran, *Acta Crystallogr., Sect. B.*, 35 (1979) 2882-2888.
9. M.J. Bunker, M.L.H. Green, C. Couldwell, and K. Prout, *J. Organomet. Chem.*, 192 (1980) C6-C8.
10. A.N. Nesmeyanov, A.I. Gusev, A.A. Pasynskii, K.N. Anisimov, N.E. Kolobova, and Yu.T. Struchkov, *J. Chem. Soc., Chem. Commun.*, (1969) 277-278; A.I. Gusev and Yu.T. Struchkov, *Zh. Strukt. Khim.*, 10 (1969) 294-303.
11. A.N. Nesmeyanov, A.I. Gusev, A.A. Pasynskii, K.A. Anisimov, N.E. Kolobova, and Yu.T. Struchkov, *J. Chem. Soc., Chem. Commun.*, (1969) 739-740.
12. A.I. Gusev and Yu.T. Struchkov, *Zh. Strukt. Khim.*, 10 (1969) 515-524.
13. N.I. Kirillova, N.E. Kolobova, A.I. Gusev, A.B. Antonova, Yu.T. Struchkov, K.N. Anisimov, and O.M. Khitrova, *Zh. Strukt. Khim.*, 15 (1974) 651-658.
14. N.I. Kirillova, A.I. Gusev, A.A. Pasynskii, and Yu.T. Struchkov, *J. Organomet. Chem.*, 63 (1973) 311-319.

15. N.I. Kirillova, A.I. Gusev, and Yu.T. Struchkov, *Zh. Strukt. Khim.*, 15 (1974) 718-720.
16. N.I. Kirillova, A.I. Gusev, and Yu.T. Struchkov, *Zh. Strukt. Khim.*, 13 (1972) 473-479.
17. N.I. Kirillova, A.I. Gusev, A.A. Pasynskii, and Yu.T. Struchkov, *Zh. Strukt. Khim.*, 14 (1973) 868-874.
18. R.D. Wilson, T.F. Koetsle, D.W. Hart, A. Kvikc, D.L. Tipton, and R. Bau, *J. Am. Chem. Soc.*, 99 (1977) 1775-1781.
19. K. Prout, T.S. Cameron, R.A. Forder, S.R. Critchley, B. Denton, and G.V. Ries, *Acta Crystallogr., Sect. B.* 30 (1974) 2290-2304.
20. I. Bkouche-Waksman, C. Bois, J. Sala-Pala, and J.E. Guerschais, *J. Organomet. Chem.*, 195 (1980) 307-315.
21. R. Mercier, J. Douglade, B. Viard, *Acta Crystallogr., Sect. B.*, 37 (1981) 949-951.
22. R. Mercier, J. Douglade, J. Amaudrut, J. Sala-Pala, and J. Guerschais, *Acta Crystallogr., Sect. B.* 36 (1980) 2986-2991.
23. M.G.B. Drew and L.S. Pu, *Acta Crystallogr., Sect. B.*, 33 (1977) 1207-1211.
24. L.J. Guggenberger, P. Meakin, and F.N. Tebbe, *J. Am. Chem. Soc.*, 96 (1974) 5420-5427.
25. P.B. Hitchcock, M.F. Lappert and R.C. Milne, *J. Chem. Soc., Dalton Trans.*, (1981) 180-186.
26. R. Mercier, J. Douglade, J. Amandryt, J. Sala-Pala, and J. Guerschais, *J. Organomet. Chem.*, 244 (1983) 145-151.
27. L.M. Angelhardt, W.P. Leung, C.L. Raston, and A.H. White, *J. Chem. Soc. Chem. Commun.*, (1983) 386-388.
28. R.R. Schrock, L.J. Guggenberger, and A.D. English, *J. Am. Chem. Soc.*, 98 (1976) 903-913.
29. L.J. Guggenberger and R.R. Schrock, *J. Am. Chem. Soc.*, 97 (1975) 6693-6700.
30. F. Naumann, J. Kopf and D. Rehder, *J. Organomet. Chem.*, 267 (1984) 249-255.
31. R. Kergoat, M.M. Kubicki, J.E. Guerschais, N.C. Norman, and A.G. Orpen, *J. Chem. Soc., Dalton Trans.*, (1982) 633-638.
32. Yu.V. Skripkin, O.G. Volkov, A.A. Pasynskii, A.S. Antsyshkina, L.M. Dikareva, V.N. Ostrikova, M.A. Porai-Koshits, S.L. Davydova, and S.G. Sakharov, *J. Organomet. Chem.*, 263 (1984) 345-357.
33. A.A. Pasynskii, J.V. Skripkin, O.G. Volkov, V.T. Kalinnikov, M.A. Porai-Koshits, A.C. Antsyshkina, L.N. Dikareva, and V.N. Ostrikova, *Izv. Akad. Nauk SSSR, Ser. Khim.*, (1983) 1207.
34. A.A. Pasynskii, Yu.V. Skripkin, I.L. Eremenko, V.T. Kalinnikov, G.G. Aleksandrov, V.G. Andrianov, and Yu.T. Struchkov, *J. Organomet. Chem.*, 165 (1979) 49-56.
35. Yu.V. Skripkin, A.A. Pasynskii, V.T. Kalinnikov, M.A. Porai-Koshits, L. Kh. Minacheva, A.S. Antsyshkina, and V.N. Ostrikova, *J. Organomet. Chem.*, 231 (1982) 205-217.
A.A. Pasynskii, A.S. Antsyshkina, Yu.V. Skripkin, V.T. Kalinnikov, M.A. Porai-Koshits, V.N. Ostrikova, and S.S. Sadikov, *Zh. Neorg. Khim.*, 26 (1981) 2435-2442.
36. M.A. Porai-Koshits, A.S. Antsyshkina, A.A. Pasynskii, G.G. Sadikov, Yu.V. Skripkin, and V.N. Ostrikova, *Koord. Khim.*, 5 (1979) 1103; *Inorg. Chim. Acta*, 34 (1979) L285-L287.
37. K.S. Wong., W.R. Scheidt, and J.A. Labinger, *Inorg. Chem.*, 18 (1979) 136-140.
38. W.A. Herrmann, H. Biersack, B. Balbach, and M.L. Ziegler, *Chem. Ber.*, 117 (1984) 95-106.
39. W.A. Herrmann, H. Biersack, B. Balbach, P. Weilknite, and M.L. Zeigler, *Chem. Ber.*, 117 (1984) 79-94.

40. K.S. Wong, W.R. Scheidt, and J.A. Labinger, *Inorg. Chem.*, 18 (1979) 1709-1712.
41. G.S. Bristow, P.B. Hitchcock, and M.F. Lappert, *J. Chem. Soc., Chem. Commun.*, (1981) 1145-1146.
42. W.E. Douglas, M.L.H. Green, C.K. Prout, and G.V. Rees, *J. Chem. Soc., Chem. Commun.*, (1971) 896-887.
43. K. Prout, S.R. Critchley, and G.V. Rees, *Acta Crystallogr., Sect. B*, 30 (1974) 2305-2311.
44. J. Amaudrut, J. Sala-Pala, J.E. Guerschais, R. Mercier, and J. Douglade, *J. Organomet. Chem.*, 235 (1982) 301-313.
45. G.G. Aleksandrov, A.I. Gusev, and Yu.T. Struchkov, *Zh. Strukt. Khim.*, 9 (1968) 333.
46. A.N. Nesmeyanov, A.I. Gusev, A.A. Pasynskii, K.N. Anisimov, N.E. Kolobova, and Yu.T. Struchkov, *J. Chem. Soc., Chem. Commun.*, (1968) 1365-1366.
47. A.I. Gusev and Yu.T. Struchkov, *Zh. Strukt. Khim.*, 10 (1969) 107-115.
48. A.I. Gusev, N.L. Kirillova, and Yu.T. Struchkov, *Zh. Strukt. Khim.*, 11 (1970) 62-70.
49. D.A. Lemenovskii, V.P. Fedin, Yu.L. Slovohtov, and Yu.T. Struchkov, *J. Organomet. Chem.*, 228 (1982) 153-170.
50. A.A. Lemenovskii, V.P. Fedin, Yu.L. Slovohtov, A.I. Janovskii, and Yu.T. Struchkov, *Koord. Khim.*, 6 (1980) 882-888.
51. L.J. Guggenberger and F.N. Tebbe, *J. Am. Chem. Soc.*, 93 (1971) 5924-5925.
52. L.J. Guggenberger, *Inorg. Chem.*, 12 (1973) 294-301.
53. Yu.V. Skripkin, I.L. Eremenko, A.A. Pasynskii, Yu.T. Struchkov, and V.E. Shklover, *J. Organomet. Chem.*, 267 (1984) 285-292.
54. W.H. Herrmann, H. Biersack, M.L. Zeigler, and B. Balbach, *J. Organomet. Chem.*, 206 (1981) C33-C37.
55. W.A. Hermann, M.L. Zeigler, K. Weidenhammer, and H. Biersack, *Angew. Chem. Int. Ed. Engl.*, 18 (1979) 960-962.
56. W.A. Herrmann, H. Biersack, M.L. Zeigler, K. Weidenhammer, R. Siegel, and D. Rehder, *J. Am. Chem. Soc.*, 103 (1981) 1692-1699.
57. N.I. Kirillova, A.I. Gusev, A.A. Pasynskii, and Yu.T. Struchkov, *Zh. Strukt. Khim.*, 14 (1973) 1075-1081.
58. M.R. Churchill and S.W.Y. Chang, *J. Chem. Soc., Chem. Commun.*, (1974) 248-249.
59. E. Hey, F. Weler, and K. Dehnicke, *Z. Anorg. Allg. Chem.*, 514 (1984) 25-38.
60. S. Baral, J.A. Labinger, W.R. Scheidt, and F.J. Timmers, *J. Organomet. Chem.* 215 (1981) C53-C56.
61. M. Melnik, *Coord. Chem. Rev.*, 47 (1982) 239-261.