

The reaction of (trifluoromethyl)dialkylaminoboranes with HF, HCl and HBr. X-Ray structure investigation of the amineboranes $(\text{CF}_3)_2\text{B}(\text{X})\text{NHMe}_2$, X = F and OH

D.J. Brauer, H. Bürger, G. Pawelke, W. Weuter and J. Wilke

Anorganische Chemie, Fachbereich 9, Universität-Gesamthochschule D-5600 Wuppertal (F.R.G.)

(Received February 2nd, 1987)

Abstract

The reactions of $\text{CF}_3\text{B}(\text{NMe}_2)_2$ (I) and $(\text{CF}_3)_2\text{BNMe}_2$ (II) with HX (X = F, Cl and Br) have been investigated. Additions with preservation of the BC bonds to yield species with tetracoordinate boron, along with some BN cleavage, were observed. While I formed boronium salts $\text{CF}_3\text{B}(\text{X})(\text{NHMe}_2)_2^+\text{X}^-$ with X = Cl and Br, $\text{CF}_3\text{BF}_2 \cdot \text{NHMe}_2$ (V) was obtained with HF. On the other hand, reactions of II with HX yielded the 1:1 adducts $(\text{CF}_3)_2\text{B}(\text{X}) \cdot \text{HNMe}_2$ in each case. Of these, the species with X = F (VI) and X = OH (IX) (obtained by hydrolysis) were examined by single crystal X-ray diffraction. Surprisingly, no difference was found between the average B–C bond lengths of these borates (VI 1.612(8), IX 1.624(4) Å) and that of II. The implications of this observation for B–CF₃ bonding are discussed.

Introduction

The (trifluoromethyl)dimethylaminoboranes $\text{CF}_3\text{B}(\text{NMe}_2)_2$ (I) and $(\text{CF}_3)_2\text{BNMe}_2$ (II) belong to the first set of fully characterized trifluoromethyl derivatives of tricoordinate boron [1]. These molecules are thermally quite unstable, decomposition of I and II with elimination of CF₂ occurring at ~140 and ~120°C, respectively. This thermal instability is supposedly associated with the weakness of the B–CF₃ bond, which was shown by an electron diffraction investigation [2] to be 0.05 Å longer than that in comparable B–CH₃ compounds.

In order to evaluate the chemical properties of I and II and to relate these properties to those of analogous methylboron derivatives, we have studied the reactions of I and II with hydrogen halides. The reaction of alkylbis(dimethylamino)boranes with HCl, HBr and HI has been studied by Nöth and Fritz [3], who showed that, depending on the size of the alkyl group, two molecules HCl are taken up according to either eq. 1 or eq. 2.

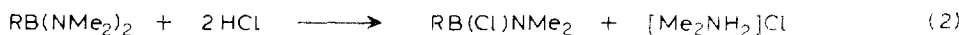
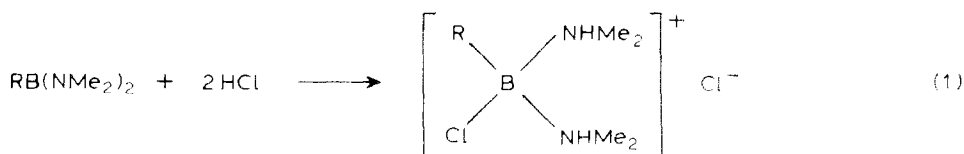

Whether the addition of HX proceeds according to eq. 1 or eq. 2 depends according to Nöth and Meister [4] on the stability of the 1:1 complex $\text{RB(X)NMe}_2 \cdot \text{NHMe}_2$. While methylboranes add HCl without B-N cleavage according to eq. 1, larger groups R direct the reaction towards the aminoborane RB(X)NMe_2 . The latter may undergo secondary reactions, e.g. as in eq. 3 and eq. 4.

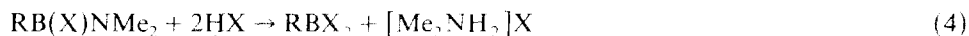

To our knowledge, the reaction of alkylbis(dialkylamino)boranes with HF has not yet been investigated.

The present study deals with the reaction of I and II with HF, HCl and HBr, and the characterization of the various novel trifluoromethylboron compounds obtained. A preliminary study was made earlier [5].

Reaction of $\text{CF}_3\text{B(NMe}_2)_2$ with HX

The reactions of I with HCl and HBr were carried out in diethyl ether at low temperature. At -78°C , colourless precipitates began to form, and at room temperature, quantitative yields of 1:2 adducts were obtained. The yields and the properties of these adducts are consistent with a clean reaction analogous to eq. 1, and the novel (trifluoromethyl)boronium halides III and IV were obtained, eq. 5.

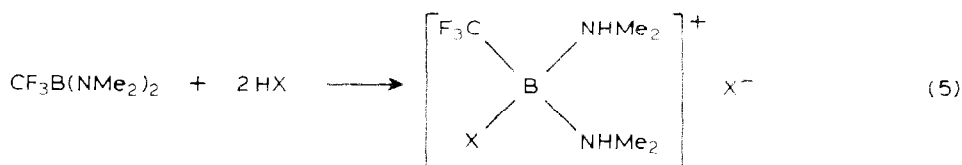

The salts III and IV are involatile, and insoluble in nonpolar solvents. NMR spectra recorded in CH_3CN suggest that this solvent reacts with III and IV, while decomposition, in part with preservation of the B-CF₃ bond, was observed with H₂O and alcohol. When the reaction with HBr was carried out in the absence of a solvent, only decomposition products (BF_3 , HCF_3 , HCF_2Br and a black, tar-like residue) were obtained.

The reaction of I with HF was carried out in a stainless steel cylinder in the absence of a solvent, and the reaction mixture was slowly warmed from -196°C to

room temperature. The clear, viscous liquid obtained was soluble in polar solvents (Et_2O , CH_3CN , H_2O) without decomposition. In CH_3CN , the ^{19}F NMR spectrum revealed two 1/1/1/1 quartets in a 3/2 integration ratio at -73.9 and -173.4 ppm, respectively which, by analogy to $\text{CF}_3\text{BF}_2 \cdot \text{NMe}_3$ [6], are attributed to $\text{CF}_3\text{BF}_2 \cdot \text{NHMe}_2$ (V). The maximum yield of V, close to 85%, was obtained when I and HF were used in a 1/3 molar ratio. If less than 3 mole HF were employed, unchanged I was found in the volatile products, while substantially more than 15% of by-products with respect to eq. 6 were formed when more than threefold excess of HF was used.

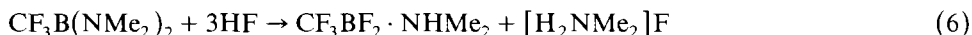

By-products identified by their ^{19}F NMR signals were: CF_3BF_3^- (-77 and -157 ppm), $\text{BF}_3 \cdot \text{HNMe}_2$ (-160 ppm), BF_4^- (-153 ppm) and F^- (-149 ppm, very broad). The amineborane V was isolated by thin layer chromatography and fully characterized.

That HF reacts differently with I than do HCl and HBr is certainly due to the strength of the BF bond. Whether V is formed according to eq. 7b via $\text{CF}_3\text{B}(\text{F})\text{NMe}_2$

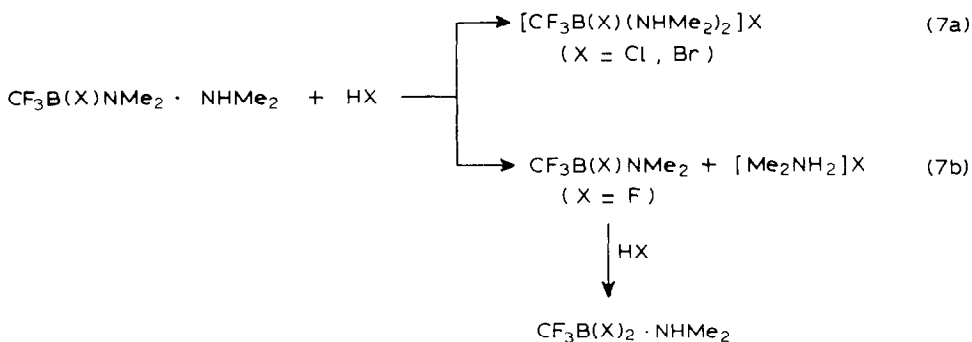

from $\text{CF}_3\text{B}(\text{X})\text{NMe}_2 \cdot \text{NHMe}_2$ which may be a common precursor for III, IV and V, cannot be decided.

Reaction of $(\text{CF}_3)_2\text{BNMe}_2$ with HX

A uniform pathway was observed for the reaction of II with HF, HCl, HBr and HOH (eq. 8) but with HF, in particular, minor amounts of by-products were observed.

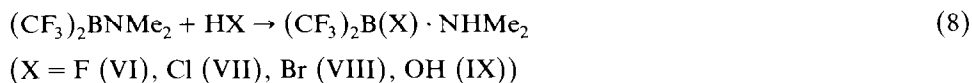

In the absence of a solvent, II and HF reacted vigorously, and complete decomposition was observed. The reaction was more moderate when carried out in Et_2O as a solvent, and the clear solution obtained contained 60–70% of VI as major constituent. The amineborane VI was removed from the solution by distillation in vacuo, and isolated by chromatography on Al_2O_3 . Single crystals grown by sublimation were studied by X-ray diffraction (see below).

The yield of VI and the amount of by-products seemed to be independent of the II/HF ratio employed. The major by-product, which was formed in ca. 15% yield,

was identified as V. Its formation requires the cleavage of a B–CF₃ bond. The presence of further minor by-products was indicated in the ¹⁹F NMR spectrum of the crude material, but they were not identified.

In ethereal solution equimolar addition of HCl, HBr and H₂O according to eq. 8 was observed, and the products VII, VIII and IX were isolated in high yields by sublimation in vacuo.

During attempts to isolate VII and VIII in analogy to VI by thin layer chromatography, quantitative hydrolysis occurred (eq. 9).

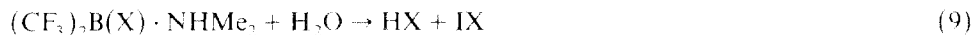

Single crystals of the boronic acid IX were obtained, and were studied by X-ray diffraction (see below).

Properties and spectra

The novel (trifluoromethyl)boron compounds III–IX were characterized by elemental analyses, NMR, IR, Raman, and mass spectra. The physical properties and the NMR spectra are shown in Table 1, while IR, Raman and MS data are given in the Experimental section. While compounds III–V are involatile, VI–IX can be sublimed in vacuo ($\sim 10^{-2}$ Torr) at room temperature. III and IV are poorly soluble in CH₃CN and insoluble in Et₂O, whereas V–IX dissolve readily in these solvents. III is slowly attacked by H₂O, whereas IV, VII and VIII are rapidly hydrolyzed.

NMR spectra

¹H, ¹⁹F and ¹¹B NMR spectra were recorded for compounds III–IX (Table 1). The low solubility of III and IV and their obvious reaction with the solvent limits

Table 1
Physical properties and NMR spectra of compounds III–IX (δ in ppm, J in Hz)

	III	IV	V	VI	VII	VIII	IX
M.p. (°C)	74	113	20	44	68	79	85
¹ H ^a		.. ^d					
$\delta(\text{CH}_3)$	2.62		2.52	2.7	2.71	2.7	2.55
² $J(\text{HN})$			3.6		4.5	5.4	9.0
$\delta(\text{NH})$	8.8		5.2		6.0		
¹⁹ F ^b		.. ^d					
$\delta(\text{CF}_3)$	–69.8		–73.9	–70.1	–67.0	–65.6	–68.7
² $J(\text{FB})$			33.0	31.0	33.2	35.0	29.4
$\delta(\text{BF})$			–173.4	–206.1			
¹ $J(\text{FB})$			48.8	60.7			
¹¹ B ^c							
$\delta(^{11}\text{B})$	1.5	.. ^d	–0.6	–3.5	–5.5	–6.8	–4.8

^a In CH₃CN, int. std. TMS. ^b In CH₃CN, int. std. C₆F₆ – 164.9 ppm. ^c In CH₃CN, ext. std. BF₃·Et₂O.
^d Not sufficiently soluble.

the value of their NMR spectra. The spectra confirm the constitution of the compounds, the ^{11}B - ^{19}F coupling patterns resolved in the ^{19}F and ^{11}B NMR spectra being of special diagnostic value. However, in several of the ^{19}F spectra the signals were broadened owing to relaxation phenomena; in some of these cases, fine structure was better resolved when a different solvent was used.

The vibrational spectra contain mainly non-specific IR bands and Raman lines. Group vibrations are also found, and a few of these are quoted in the Experimental section and assignments made.

In the mass spectra, the M^+ ion was observed only for V, while VI, VIII and IX showed the typical $(M - \text{CF}_3)^+$ fragment. Typical ions are CF_2^+ ($m/e = 50$), CF_3^+ ($m/e = 69$) and NMe_2^+ ($m/e = 44$). The observed fragments in each case were in agreement with the proposed formulation.

X-Ray structural analyses

Crystals of VI and IX were sealed in glass capillaries under argon. The space group of IX was uniquely determined from the symmetry and systematic absences

Table 2
Crystal data for VI and IX

	VI	IX
Formula	$(\text{CF}_3)_2\text{BF} \cdot \text{NMe}_2\text{H}$	$(\text{CF}_3)_2\text{B}(\text{OH}) \cdot \text{NMe}_2\text{H}$
M_r	212.09	210.91
Crystal system	monoclinic	monoclinic
Space group	$C2/c$	$P2_1/n$
a (Å)	13.052(4)	11.562(3)
b (Å)	7.118(3)	6.256(1)
c (Å)	19.454(5)	12.226(2)
β (°)	110.76(3)	107.54(2)
Z	8	4
D_c (g cm^{-3})	1.667	1.661
T (°C)	23	23
Quadrants measured	$hkl, \bar{h}kl$ $hkl, \bar{h}k\bar{l}$	$hkl, \bar{h}k\bar{l}$
2θ -limits (°)	4–45	4–50
Measured reflections	2139	1737
Unique reflections	1098	1483
Observed ($ F_o > 4\sigma(F_o)$)	673	1085
Crystal size (mm)	$0.08 \times 0.16 \times 0.32$	$0.26 \times 0.30 \times 0.35$
$\mu(\text{Mo} - K_\alpha)$ (cm^{-1})	2.0	1.9
Transmission	0.9681–0.9851	0.9347–0.9691
Monitor correction	0.984–1.120	0.992–1.075
Parameters	124	128
$ \xi/\sigma _{\max}$	0.0	0.0
R^a	0.060/0.107 ^b	0.041/0.074
R_w^c	0.044/0.047	0.042/0.043
ρ ($\text{e}/\text{Å}^3$) ^d	0.25 to –0.19	0.24 to –0.20

^a $R = \sum |F_o| - |F_c| / \sum |F_o|$. ^b First sum only over observes, second over all unique data. ^c $R_w = [\sum w(|F_o| - |F_c|)^2 / \sum w |F_o|^2]^{1/2}$ where $w = 1/(\sigma^2(F_o) + 0.0009 |F_o|^2)$. ^d Density in final difference Fourier syntheses.

Table 3

Positional and isotropic or equivalent isotropic ^a temperature factors for the nongroup atoms of VI

Atom	x	y	z	U
F(1)	0.3347(3)	0.2946(6)	0.0754(2)	0.127(2)
F(2)	0.3719(3)	0.1701(5)	0.1803(2)	0.109(2)
F(3)	0.4391(3)	0.4325(5)	0.1691(2)	0.109(2)
F(4)	0.1547(4)	0.5668(6)	0.0310(2)	0.157(3)
F(5)	0.2784(3)	0.7319(5)	0.1038(3)	0.150(3)
F(6)	0.1246(4)	0.7129(6)	0.1142(3)	0.185(4)
F(7)	0.2805(2)	0.5048(4)	0.2288(1)	0.082(1)
N	0.1526(4)	0.2871(6)	0.1517(3)	0.053(2)
C(1)	0.3459(5)	0.333(1)	0.1446(3)	0.070(3)
C(2)	0.1998(6)	0.611(1)	0.1008(4)	0.090(4)
C(3)	0.0614(4)	0.3616(8)	0.1739(3)	0.101(4)
C(4)	0.1060(4)	0.1810(7)	0.0810(3)	0.081(3)
B	0.2445(5)	0.4376(8)	0.1569(3)	0.052(3)
H(N)	0.185(4)	0.199(7)	0.184(3)	0.07(2)

^a $U = \frac{1}{3} \sum_i \sum_j U_{ij} \bar{a}_i \cdot \bar{a}_j a_i^* a_j^*$ for anisotropically refined atoms.

revealed by Weissenberg photographs. The choice between the space groups $C2/c$ and Cc for VI was ultimately based on the good refinement achieved in the former.

Intensity data were obtained with a Siemens AED-1 diffractometer employing Zr-filtered Mo- K_{α} radiation (λ 0.71073 Å) as described previously [7]. The intensities were corrected for the decay of three monitor reflections and for absorption.

The structures were solved by direct methods and refined by full-matrix least-squares techniques. Difference Fourier syntheses following anisotropic refinement of the nonhydrogen atoms revealed the hydrogen positions. These atoms were assigned isotropic parameters, and while the methyl groups were idealized (C-H 0.95 Å, staggered), no constraints were applied to the other hydrogen atoms. The

Table 4

Positional and isotropic or equivalent isotropic ^a temperature factors for the nongroup atoms of IX

Atom	x	y	z	U
F(1)	0.5752(2)	0.0954(3)	0.2737(2)	0.0726(8)
F(2)	0.6079(2)	0.1564(3)	0.1137(2)	0.0696(8)
F(3)	0.7074(1)	0.3273(3)	0.2653(2)	0.0776(8)
F(4)	0.3937(2)	0.3816(3)	0.3295(2)	0.088(1)
F(5)	0.4028(2)	0.7053(3)	0.2839(2)	0.0788(9)
F(6)	0.5627(2)	0.5514(5)	0.3822(2)	0.097(1)
O	0.5425(2)	0.6261(3)	0.1284(2)	0.0438(7)
N	0.3795(2)	0.3711(3)	0.0783(2)	0.0399(7)
C(1)	0.5951(2)	0.2563(4)	0.2080(2)	0.050(1)
C(2)	0.4636(3)	0.5188(5)	0.2933(2)	0.055(1)
C(3)	0.2775(2)	0.5287(5)	0.0501(3)	0.061(1)
C(4)	0.3320(3)	0.1528(5)	0.0891(3)	0.059(1)
B	0.4969(2)	0.4496(5)	0.1777(2)	0.0398(9)
H(O)	0.583(3)	0.700(6)	0.168(3)	0.06(1)
H(N)	0.404(2)	0.361(4)	0.021(2)	0.040(7)

^a See Table 3.

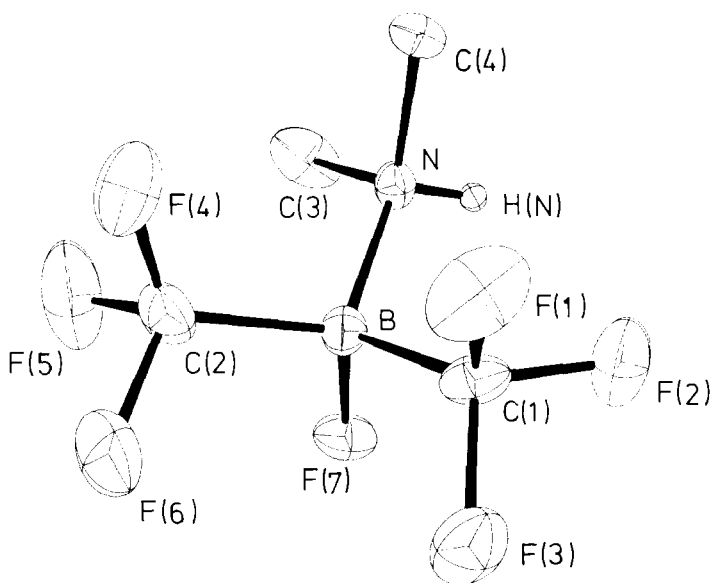

Fig. 1. A perspective drawing of VI with methyl hydrogens omitted.

refinements converged, and the final difference Fourier maps contained no chemically significant features.

Crystallographic details are given in Table 2, and coordinates of the non-idealized atoms of VI and IX are listed in Tables 3 and 4, respectively, with the numbering schemes being defined in Figs. 1 and 2 [8]. Most of the calculations were made with SHELX-76 [9].

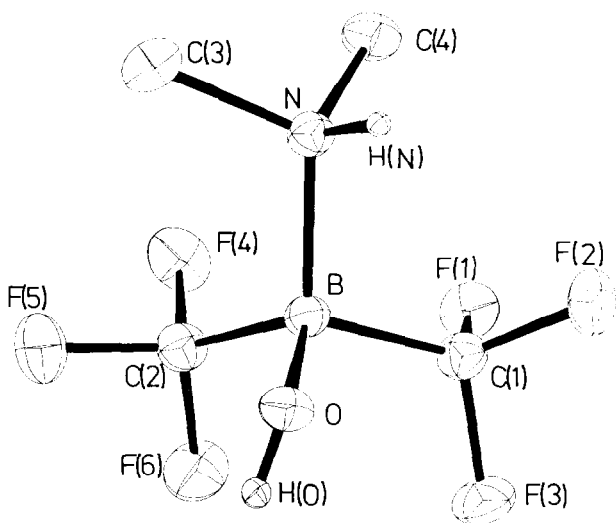

Fig. 2. A perspective drawing of IX with methyl hydrogens omitted.

Description of the crystal structures

Bond distances and angles are given in Tables 5 and 6, respectively. The boron bond lengths have been corrected for librations [10] of the $C_2B(F)N$ and $C_2B(N)O$ fragments, while librational corrections to the C–F distances resulted from analyses of the thermal motion of the BCF_3 fragments. Librational shortening has been found to be larger for VI than for IX, and this tends to compensate for the fact that uncorrected bond distances in VI are somewhat shorter than corresponding values in IX. Unless otherwise indicated, uncorrected values are used in the following discussion.

Table 5

Selected interatomic distances (Å) in VI and IX

	VI	IX		VI	IX
B–C(1)	1.610(7)	1.621(4)	C(1)–F(1)	1.329(6)	1.354(3)
B–C(2)	1.614(8)	1.626(4)	C(2)–F(4)	1.314(7)	1.341(3)
B–C ^a	1.612(8)	1.624(4)	C(1)–F(2)	1.330(6)	1.355(3)
B–C ^{a,b}	1.626(8)	1.629(4)	C(2)–F(5)	1.318(7)	1.350(3)
B–X ^c	1.393(6)	1.432(3)	C(1)–F(3)	1.342(6)	1.351(3)
B–X ^{b,c}	1.409	1.437	C(2)–F(6)	1.323(7)	1.334(3)
B–N	1.584(7)	1.602(3)	C–F ^a	1.326(10)	1.348(8)
B–N ^b	1.596	1.606	C–F ^{a,b}	1.372(6)	1.370(5)
N–C(3)	1.500(6)	1.495(3)	N–H(N)	0.88(5)	0.85(2)
N–C(4)	1.497(6)	1.495(3)	O–H(O)		0.68(3)
N...X' ^d	2.961(5)	2.926(3)	H(N)...X' ^d	2.11(5)	2.08(3)
C(3)...F(5)	2.994(8)	2.998(3)	F(1)...F(4)	2.929(6)	2.983(3)
C(4)...F(1)	3.131(7)	3.058(4)	F(3)...F(6)	2.943(6)	2.871(3)
C(4)...F(4)	3.055(7)	3.151(3)	H(N)...F(2)	2.47(5)	2.63(3)

^a Average values with standard deviations defined by the larger of $[\Sigma(l-l)^2/(n-1)]^{1/2}$ or $(\Sigma\sigma)/n$ with σ from uncorrected values. ^b Distances corrected for librational shortening. ^c X is F(7) in VI and O in IX. ^d In VI related to F(7) by $0.5-x, y-0.5, 0.5-z$; in IX related to O by $1-x, 1-y, 1-z$.

Table 6

Selected bond angles (°) in VI and IX

	VI	IX		VI	IX
C(1)–B–C(2)	112.0(5)	109.6(2)	F(1)–C(1)–B	116.4(5)	117.1(2)
C(1)–B–N	108.7(4)	108.6(2)	F(4)–C(2)–B	115.9(6)	116.1(2)
C(2)–B–N	113.0(5)	111.9(2)	F(2)–C(1)–B	113.4(4)	113.7(2)
C(1)–B–X ^a	107.8(4)	110.1(2)	F(5)–C(2)–B	113.8(6)	114.1(2)
C(2)–B–X ^a	109.2(5)	112.2(2)	F(3)–C(1)–B	113.0(5)	111.8(2)
N–B–X ^a	105.9(4)	104.4(2)	F(6)–C(2)–B	112.3(6)	112.2(2)
C(3)–N–B	113.8(4)	113.8(2)	F(1)–C(1)–F(2)	105.6(5)	104.0(2)
C(4)–N–B	116.9(4)	117.8(2)	F(4)–C(2)–F(5)	104.2(7)	103.5(2)
H(N)–N–B	106(3)	104(2)	F(1)–C(1)–F(3)	103.2(5)	104.0(2)
C(3)–N–C(4)	109.7(4)	109.4(2)	F(4)–C(2)–F(6)	105.0(6)	106.2(2)
C(3)–N–H(N)	106(3)	107(2)	F(2)–C(1)–F(3)	104.1(5)	105.0(2)
C(4)–N–H(N)	103(3)	104(2)	F(5)–C(2)–F(6)	104.7(6)	103.6(2)
B–O–H(O)	–	118(5)	F–C–F ^b	104.5(8)	104.4(10)
N–H(N)...X' ^c	161(3)	173(2)			

^a X is F(7) in VI and O in IX. ^b Average angle. ^c See Table 5.

The boron atoms are bonded in a distorted tetrahedral fashion, with quasi-staggered orientations for the CF_3 and Me_2NH groups. While the molecules could possess C_s symmetry if the N-H(N) bond lay in the plane defined by atoms B, N, F(7) in VI or by N, B, O in IX, the N-C(4) bonds adopt this position in both structures and so, the molecules exhibit no symmetry.

No significant difference is found between the mean B-C bond lengths of VI and IX: 1.612(8) and 1.624(4) Å, respectively. These distances do not differ significantly from that in $\text{K}[\text{CF}_3\text{BF}_3]$, 1.625(6) Å [11], or that involving the staggered CF_3 group in $\text{Cs}[(\text{CF}_3)_2\text{BF}_2]$, 1.603(9) Å [12]. Furthermore, the B-F bond length in VI (1.393(6) Å) is indistinguishable within the limits of error from those in $\text{K}[\text{CF}_3\text{BF}_3]$ and $\text{Cs}[(\text{CF}_3)_2\text{BF}_2]$ (1.391(5) and 1.391(4) Å, respectively).

The B-N bond length in VI, 1.584(7) Å, is not significantly shorter than that of IX, 1.602(3) Å. Both values are shorter than the corresponding distances in the chelate 3-aminopropanolato-diphenylboron (1.639(3) Å [13]). While the latter compound has its B-N and B-O bonds in a six-membered ring, its N-B-O angle ($104.9(1)^\circ$) hardly differs from that of IX ($104.4(2)^\circ$). The B-O distance in IX, 1.432(3) Å, is also shorter than that of the chelate, 1.478(2) Å [13]. The relative shortness of the B-N and B-O bonds found in VI and IX may be attributable to the inductive-withdrawing effect of the CF_3 group.

A consistent trend is found for the nitrogen bond angles of VI and IX; that is, $\text{B-N-C(4)} > \text{B-N-C(3)} > \text{B-N-H(N)}$. This trend reflects the asymmetrical nature of the $\text{CF}_3 \cdots \text{Me}_2\text{NH}$ steric interactions. These are greater for C(4) (close to F(1) and F(4)) than for C(3) (only close to F(5)) and of course least for H(N) (close to F(2)). In addition, these nonbonded contacts should cause distortions of the BCF_3 fragments; however, the geometry of the latter will also reflect nonbonded $\text{CF}_3 \cdots \text{CF}_3$ interactions, since F(1) and F(3) come close to F(4) and F(6) respectively. Thus the B-C(1)-F(1) and B-C(2)-F(4) angles are on the average $3.4(10)^\circ$ larger than the other B-C-F angles, since F(1) and F(4) are involved in both $\text{CF}_3 \cdots \text{Me}_2\text{NH}$ and $\text{CF}_3 \cdots \text{CF}_3$ interactions.

Another feature which would lengthen these repulsive contacts would be the rotation of the CF_3 and Me_2NH groups away from the all-staggered conformation. Examination of the torsion angles reveals that this has occurred. The mean rotation about the C(1)-B , C(2)-B and N-B bonds (0° being exactly staggered) are $15(3)$, $5(1)$ and $-2(4)^\circ$ in VI and $14(3)$, $13(2)$ and $11(4)^\circ$ in IX – a positive angle indicating a counter-clockwise rotation. For comparison, analogous rotations of up to 18° have been reported in the gas phase for $\text{C}(\text{CF}_3)_4$, $(\text{CF}_3)_3\text{CH}$ and $(\text{CF}_3)_3\text{COH}$ [14].

The shortest $\text{Me} \cdots \text{F}$ and intergroup $\text{F} \cdots \text{F}$ contacts are found to be 0.18 and 0.07 Å shorter (Table 5), than the corresponding sums of the Van der Waals radii, 3.17 and 2.94 Å [15]. For comparison, these contacts would be 0.20 and 0.05 Å shorter than the respective observed values if the molecules possessed tetrahedral boron, all-staggered conformations, and undistorted observed mean distances and angles.

The departures from the all-staggered conformation are probably the softest energetically of the distortions described; therefore, the variation in the rotation angles of VI suggests that the effects of packing forces on these angles may be important. These forces will not be identical for these compounds since they have different hydrogen bonding patterns. The nitrogen atoms of both compounds serve

as proton donors. In VI, the acceptor is the boron-bonded F(7)' atom in a screw-related molecule; thus these molecules are linked into infinite chains. The N...F(7)' separation, 2.961(5) Å, is slightly shorter than that of the shortest hydrogen bond of H₃N·BF₃, 3.02(2) Å [16]. In IX, the acceptor is the O' atom in an inversion-related molecule; thus this interaction leads to the formation of centrosymmetric dimers. The N...O' distance, 2.926(3) Å, is equal to the mean intramolecular N...O contact in the 18-crown-6 complex of H₃N·BF₃, 2.93(2) Å [17].

Discussion

In the reaction pathway illustrated in eq. 7 the 1:1 complex RB(X)(NMe₂)·HNMe₂ is obviously the key intermediate. Only if this is stable, i.e. the borane RB(X)NMe₂ is a strong Lewis acid, can the formation of ionic species according to eq. 7a occur. This is the case for R = CH₃, C₆H₅ and CF₃ if X = Cl and Br. The observation that the reaction follows eq. 7b for R = CF₃ and X = F makes it more likely that electronic rather than steric effects, which are inherent to the borane RB(X)NMe₂, determine the constitution of the HX addition products.

The most conspicuous effect of adding HF or H₂O to II is the lengthening of the B-N distance from 1.425(18) Å in II [2] to about 1.60 Å in VI and IX. The lengthening is obviously due to the quaternization of the boron and nitrogen atoms with subsequent loss of the N(*pπ*) → B(*pπ*)π bond in II.

While addition of HF or H₂O to II reduces the C-B-C angle from 122.2(15) in II to 112.0(5) and 109.6(2)° in VI and IX, respectively, the B-C bond lengths remain remarkably constant (II: 1.623(4) Å; VI: 1.612(8) Å; IX: 1.624(4) Å). This behaviour is in contrast to the lengthening often reported for B-CH₃ bonds upon quaternization: for example, these bond lengths increase from 1.578(1) Å in BMe₃ [18] to 1.614(5) and 1.634(7) Å in Me₂BC₆H₄-*o*-C(H)NN(H)Me [19] and LiBMe₄ [20] respectively.

Obviously no difference in the quaternization effect on B-CH₃ and B-CF₃ distances would be detectable if the B-CF₃ bonds in II were not unusually long. These bonds are believed to have been lengthened by repulsions between the positively charged boron and CF₃ carbon atoms [2]. Addition of HF or H₂O to II should tend to neutralize the charge on the boron atom and thus reduce this component of B-C repulsions. However the additions do not lead to B-C bond shortening since other factors such as boron rehybridization and steric repulsions at the same time tend to lengthen these bonds.

With the positive charge on the boron atoms being less in VI and IX than that in II, the electron density in the CF₃ groups of the borates should also be greater than the corresponding densities in II. This would lead to inductive weakening of the C-F bonds, and the corrected mean distance in the borates (1.371(6) Å) is indeed somewhat larger than the gas phase value for II, 1.343(2) Å [2].

Experimental

Starting materials

CF₃B(NMe₂)₂ (I) and (CF₃)₂BNMe₂ (II) were prepared as described previously [1] in yields of 20 and 17%, respectively.

Table 7
Elemental analyses

Compound	Formula	Analyses (Found (calc)(%))				
		C	H	Br/Cl	F	N
III	C ₅ H ₁₂ BCl ₂ F ₃ N ₂	24.9 (24.93)	5.7 (5.86)	31.0 (29.43)	22.2 (23.66)	11.6 (11.63)
IV	C ₅ H ₁₄ BBr ₂ F ₃ N ₂	18.2 (18.21)	4.2 (4.28)	48.5 (48.46)	17.1 (17.28)	8.5 (8.49)
V	C ₃ H ₇ BF ₃ N	22.1 (22.12)	4.2 (4.34)		57.7 (58.31)	8.6 (8.60)
VI	C ₄ H ₇ BF ₇ N	22.7 (22.56)	3.3 (3.32)		62.2 (62.46)	6.5 (6.58)
VII	C ₄ H ₇ BClF ₆ N	21.0 (20.95)	3.1 (3.08)	15.41 (15.46)	49.4 (49.70)	6.1 (6.11)
VIII	C ₄ H ₇ BBrF ₆ N	17.4 (17.55)	2.6 (2.58)	30.3 (29.18)		5.1 (5.12)
IX	C ₄ H ₈ BF ₆ NO	23.3 (22.78)	4.0 (3.83)		52.3 (54.04)	6.7 (6.64)

(Trifluoromethyl)bis(dimethylamino)chloro boronium chloride (III) and (trifluoromethyl)bis(dimethylamino)bromo boronium bromide (IV)

Dry HCl (HBr) (20 mmol) was condensed into a mixture of I (1.7 g, 10 mmol) in 5 ml dry Et₂O kept at -196°C, the mixture was then allowed to warm from -78°C to room temperature during 12 h. The Et₂O was then removed in vacuo. Analytically pure III (IV) was obtained in 98 (99)% yield. Selected IR absorptions III/IV: 1475m/1472m ($\delta_{as}(\text{CH}_3)$), 1285m/1278m ($\delta_s(\text{CH}_3)$), 1089s, 1078s/1092s, 1073s($\nu_{as}(\text{CF}_3)$), 708m/704m ($\delta_s(\text{CF}_3)$). For elemental analyses see Table 7.

(Trifluoromethyl)difluoroborane · dimethylamine (V)

In an analogous procedure, I (1.7 g, 10 mmol) was reacted with HF (0.6 g, 30 mmol) in a stainless steel cylinder. Unreacted volatile material was removed in vacuo and V separated from ammonium fluoride by liquid chromatography in CH₂Cl₂ over a Al₂O₃ (Al) column, yield ca. 50%. Selected IR absorptions: 3273m ($\nu(\text{NH})$), 1479m ($\delta_{as}(\text{CH}_3)$), 1080s, 1025s ($\nu_{as}(\text{CF}_3)$), 714m, ($\delta_s(\text{CF}_3)$). MS: $m/e = 95$ (HCF₂NMe₂)⁺, 100%; 94/93 (^{11/10}BF₂HNMe₂)⁺, 72/18%; 69 (CF₃)⁺, 14%.

Bis(trifluoromethyl)fluoroborane · dimethylamine (VI), bis(trifluoromethyl)chloroborane · dimethylamine (VII), bis(trifluoromethyl)bromoborane · dimethylamine (VIII) and bis(trifluoromethyl)boronic acid · dimethylamine (IX) were obtained from analogous reactions of 1.9 g (10 mmol) II and 10 mmol HF, HCl, HBr and H₂O, respectively. After removal of Et₂O and volatile by-products in vacuo, VI-IX were obtained by sublimation in yields of 46, 93, 95, and 94%, respectively. Purification of VI was carried out by thin layer chromatography using MERCK 60 F 254 plates and CH₂Cl₂ as eluent before sublimation. Selected IR absorptions: VI-IX: 1481m ($\delta_{as}(\text{CH}_3)$), 1096vs br ($\nu_{as}(\text{CF}_3)$), 692s/684s/683s/688s ($\delta_s(\text{CF}_3)$). IX: 3654s ($\nu(\text{OH})$).

Acknowledgements

We wish to thank the Fonds der Chemie for financial support.

References

- 1 H. Bürger, M. Grunwald and G. Pawelke, *J. Fluor. Chem.*, 31 (1986) 89.
- 2 R. Hausser-Wallis, H. Oberhammer, H. Bürger and G. Pawelke, *J. Chem. Soc., Dalton Trans.*, in press.
- 3 H. Nöth and P. Fritz, *Z. Anorg. Allgem. Chem.*, 322 (1963) 297.
- 4 H. Nöth and W. Meister, *Z. Naturforsch. B.* 17 (1962) 714.
- 5 M. Grunwald, Dissertation, Wuppertal (1985).
- 6 H. Bürger, M. Grunwald and G. Pawelke, *J. Fluor. Chem.*, 28 (1985) 183.
- 7 D.J. Brauer, H. Bürger, G.R. Liewald and J. Wilke, *J. Organomet. Chem.* 287 (1985) 305.
- 8 Additional crystallographic tables may be obtained from Fachinformationszentrum Energie-Physik-Mathematik GmbH, D-7514 Eggenstein-Leopoldshafen 2, by quoting the deposit number CSD 52401, the names of the authors and the literature reference.
- 9 G.M. Sheldrick, *SHELX-76: Program for crystal structure determination*, University of Cambridge, England, 1976.
- 10 V. Shomaker and K.N. Trueblood, *Acta Crystallogr. Sect. B*, 24 (1968) 63.
- 11 D.J. Brauer, H. Bürger and G. Pawelke, *Inorg. Chem.*, 16 (1977) 2305.
- 12 D.J. Brauer, H. Bürger and G. Pawelke, *J. Organomet. Chem.*, 192 (1980) 305.
- 13 S.J. Rettig and J. Trotter, *Can. J. Chem.*, 61 (1983) 2334.
- 14 H. Oberhammer, *J. Chem. Phys.*, 69 (1978) 468.
- 15 A. Bondi, *J. Phys. Chem.*, 68 (1964) 441.
- 16 J.L. Hoard, S. Geller and W.M. Cashin, *Acta Crystallogr.*, 4 (1951) 396.
- 17 H.M. Colquhoun, G. Jones, J.M. Maud, J.F. Stoddart and D.J. Williams, *J. Chem. Soc., Dalton Trans.*, (1984) 63.
- 18 L.S. Bartell and B.L. Carroll, *J. Chem. Phys.*, 42 (1965) 3076.
- 19 C. Svensson, *Acta Crystallogr., Sect. B*, 32 (1976) 3341.
- 20 W.E. Rhine, G. Stucky and S.W. Peterson, *J. Amer. Chem. Soc.*, 97 (1975) 6401.