

Journal of Organometallic Chemistry, 416 (1991) 1–200
 Elsevier Sequoia S.A. Lausanne
 JOM 21523AS

SILICON-THE SILICON-CARBON BOND: ANNUAL SURVEY FOR THE YEAR 1988*

Gerald L. Larson
 Head of Applications Technology
 Department of Silicon Chemistry
 Hüls Aktiengesellschaft-Troisdorf Plant
 P.O. Box 1347
 D-5210 Troisdorf
 West Germany

I. INTRODUCTION	2
II. REVIEWS	3
III. DISSERTATIONS	4
IV. ALKYL SILANES	5
A. Preparation	5
B. Reactions	8
C. Other Studies	10
V. ARYL SILANES	10
A. Preparation	10
B. Reactions	20
C. Other Studies	28
VI. HYDROSILYLATION	32
A. New Developments	32
B. Hydrosilation of Alkenes	32
C. Hydrosilation of Alkynes	36
D. Hydrosilation-Reductions	37
VII. VINYL SILANES	38
A. Preparation	38
B. Reactions	50
C. Other Studies	63
VIII. ETHYNYL SILANES	63
A. Preparation	63
B. Reactions	66
C. Other Studies	72
IX. ALLYL SILANES	73
A. Preparation	73
B. Reactions	80
C. Other Studies	101
X. PROPARGYL SILANES	101

* Sorry, no reprints of this article are available.

XI. BENZYL SILANES	104
A. Preparation	104
B. Reactions	107
XII. α-FUNCTIONAL ORGANOSILANES	109
A. Preparation	109
B. Reactions	113
C. α -Metallated Organosilanes	122
D. Other Studies	132
XIII. β-FUNCTIONAL ORGANOSILANES	133
A. Preparation	133
B. Reactions	135
C. Other Studies	144
XIV. MISCELLANEOUS FUNCTIONAL ORGANOSILANES	145
A. γ -Functional Organosilanes	145
B. Epoxysilanes	150
C. Acylsilanes	151
XV. REACTIVE SPECIES	159
A. Radicals	159
B. Silylenes	159
C. Silenes	165
D. Disilenes	172
E. Silanones	173
F. Miscellaneous Reactive Organosilane Species	175
XVI. ACKNOWLEDGEMENTS	178
XVII. REFERENCES	179

I. INTRODUCTION

This section of the annual survey of organosilicon chemistry covers material appearing in volumes 108 and 109 of Chemical Abstracts. It is the intent of the author to be as thorough as possible without being redundant in presenting the results of the chemistry of the silicon-carbon bond and carbofunctional organosilanes. Liberal use of abbreviations is used. These should, however, be familiar to the practiced chemist. An honest attempt has been made to arrange the subject matter into categories, but due to the multiple nature of much of the chemistry this is not always possible, thus the reader is advised to peruse all sections.

II. REVIEWS

Two volumes of "The chemistry of organic silicon compounds" were published. These include chapters on 1. historical overview and comparison with carbon, 2. theoretical aspects, 3. structural chemistry, 4. dynamic stereochemistry at silicon, 5. thermochemistry, 6. analysis of organosilicon compounds, 7. positive and negative ion chemistry of silicon compounds, 8. NMR spectroscopy, 9. photoelectron spectroscopy, 10. general synthetic pathways to organosilanes, 11. recent synthetic applications of organosilanes, 12. acidity, basicity and complex formation of organosilanes, 13. reaction mechanisms of nucleophilic attack at silicon, 14. activating and directive effects of silicon, 15. photochemistry of organosilanes, 16. trivalent silyl ions, 17. multiple bonds to silicon, 18. bioorganosilicon chemistry, 19. polysilanes, 20. hypervalent silicon compounds, 21. siloxane polymers and copolymers, 22. organosilicon derivatives of phosphorus, arsenic, antimony and bismuth, 23. chemistry of compounds with silicon-sulphur, silicon-selenium and silicon-tellurium bonds, 24. transition-metal silyl derivatives, and 25. the hydrosilation reaction.

Thirty two reviews were reported. These, along with their particular topics, are given. The number of references to be found in each is given in parentheses. The organosilicon survey for 1985 appeared (532) [2] as did studies of metallocarborane derivatives of aluminum and silicon (41) [3], the synthesis and reactions of phosphorus rich silyl phosphines (3) [4] and (54) [5], structural chemistry of organosilanes (126) [6], carbonylation of organolithium reagents including acylation of silanes (23) [7], chemistry of the silicon-silicon double bond (74) [8], addition of silyl radicals to unsaturated compounds (166) [9], carbon-silicon cleavage by electron transfer processes (45) [10], silylcelluloses (23) [11], silylcobalt carbonyl and new catalytic reactions (33) [12], reactions of organosilicon and organogermanium derivatives of furan (37) [13], organosilthianes (215) [14], phase-transfer catalysis in organosilicon

chemistry (85) [15], synthesis of vinylsilanes (24) [16], catalytic asymmetric synthesis including hydrosilation (43) [17], silyl ether and ester protecting groups (89) [18], protection of primary amines as stabase adducts (4) [19], trimethylsilyl azide (30) [20], α -silylated sulfones (40) [21], generation of 1,3-dipoles from organosilanes (46) [22], pyridylsilanes in synthesis (58) [23], stereocontrol using silicon compounds (25) [24], radical cyclization in control of regio- and stereochemistry (17) [25], additions of allyl- and propargylsilanes to acceptors (30) [26], intramolecular additions of allyl- and propargylsilanes (73) [27], organosilanes as selective intermediates in synthesis (57) [28], selective syntheses with organosilanes and organoalanes (12) [29], use of organosilanes in synthesis (28) [30], preparation and use of organosilanes in synthesis (455) [31], synthetic reactions of organosilanes (21) [32], synthetic aspects of organosilanes under nucleophilic conditions (411) [33].

III. DISSERTATIONS

Eighteen dissertations with organosilicon chemistry as the principle theme or a part were reported. These include the desilylation of α -silyl onium salts as a route to ylides and 1,3-dipoles [34], γ -silylated- α,β -unsaturated amides [35], β - and γ -hydroxy-silanes in organic synthesis [36], reactions of trimethylsilyl tetrasubstituted sulfonyl-cyclopropanes [37], oxonium ion initiated cyclizations of vinylsilanes and alkenes [38], the use of N-trimethylsilylmethylallyliminium salt photocyclization methodologies in synthesis [39], synthesis of nucleoside and silyl nucleotide analogs [40], chemistry of 1,3,5-tris(trimethylsiloxy)-1-methoxy-1,3,5-triene [41], silafunctional tricyclic heterocycles [42], cyclization of trimethylsilyl substituted α -allenic alcohols [43], aryne cycloadducts of 1,3-bis(trimethylsilyl)- and 1-ethoxy-3-(trimethylsilyl)iso-benzofurans [44], thermally induced rearrangements of silylallenes in the gas phase

[45], γ -silicon stabilization of carbonium ion intermediates in solvolysis reactions [46], use of the trimethylsilyl group as a removable stereocontrol element [47], the stereo-chemistry of silenes and α -lithiosilanes [48], reactions of alkoxy- and alkyliridium complexes with alkynes and silanes [49], fluorine containing ketene silyl acetals [50], and reactions of nickel-silyl complexes in their high oxidation states [51].

IV. ALKYL SILANES

A. Preparation

The higher boilers (bottoms) from the direct process between methyl chloride and silicon metal were analyzed by chromatography-mass spectrometry. It was found to contain various disiloxanes, bis(silyl)methanes, bis(silyl)ethanes and trisiloxanes. [52]

A process for preparing alkyldimethylchlorosilanes directly from alkyl chlorides and dimethyldichlorosilane in a Wurtz reaction was presented. (Eqn. 1)

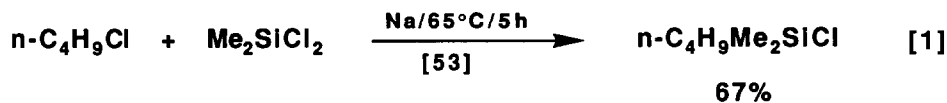

It was also found that the reaction of trialkylaluminums and sodium tetraalkylaluminates with halosilanes gives good yields of the alkylsilanes. (Eqns. 2 and 3)

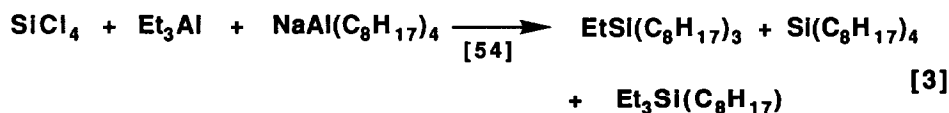
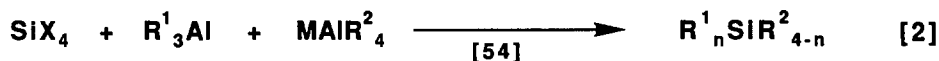

The coreaction of tri- or dialkylchlorosilanes and methylene chloride with magnesium and zinc in tetrahydrofuran gives bis tri- dialkylsilylmethanes. (Eqn. 4)

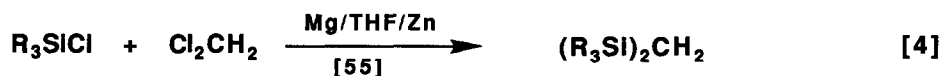

The reactivity of the dianionic hexacoordinated silicon complex **1**, prepared directly from silicon dioxide and catechol, (Eqn. 5) with organomagnesium reagents was investigated. This was used to prepare trisubstituted silanols (Eqn. 6), tetra-substituted silanes (Eqn. 7) and silaspiro systems (Eqn. 8).

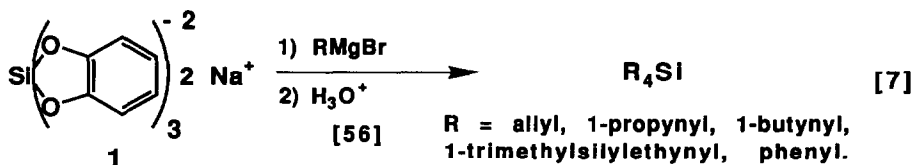
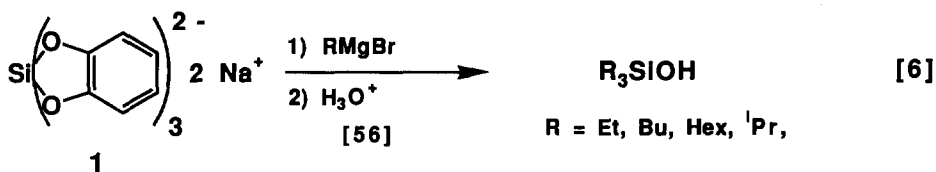
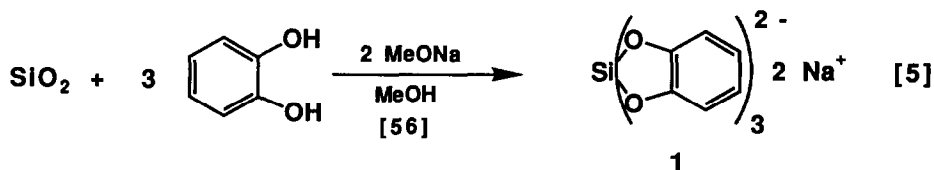

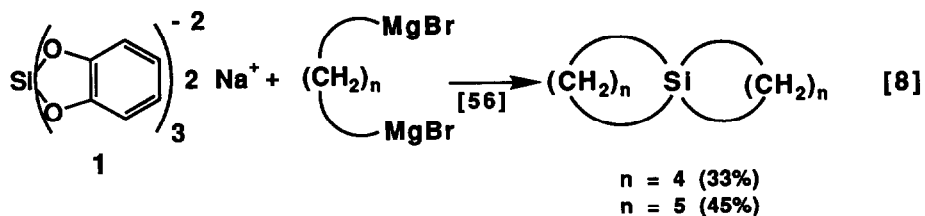

The asymmetric synthesis of organosilanes was accomplished by the reaction of 1-naphthylmagnesium bromide or 1-naphthyllithium with dioxasilole **2**. (Eqns. 9 and 10)

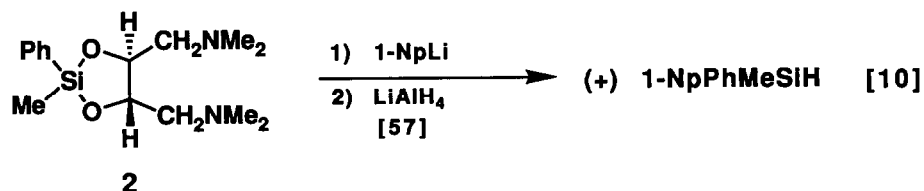
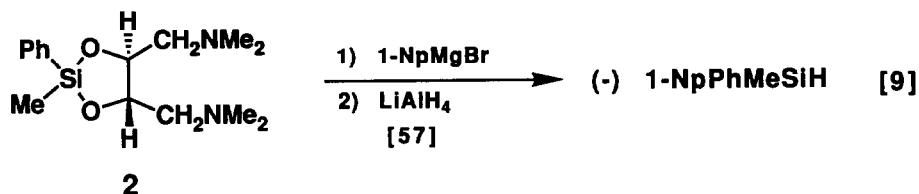

Tris(trimethylsilyl)methyl lithium was shown to nicely react with dialkyldifluorosilanes and alkyltrifluorosilanes to give the corresponding trisylfluorosilanes. (Eqn. 11)

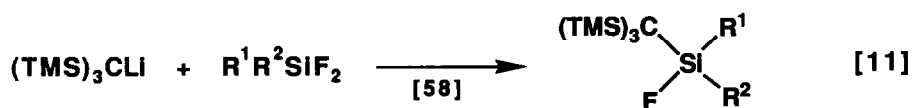

The synthesis of some bridgehead substituted organosilanes was reported

starting from the bridgehead lithium reagent. (Eqn. 12) The ^{29}Si NMR spectra were recorded and the ^{29}Si - ^{13}C coupling constants for these systems were given.

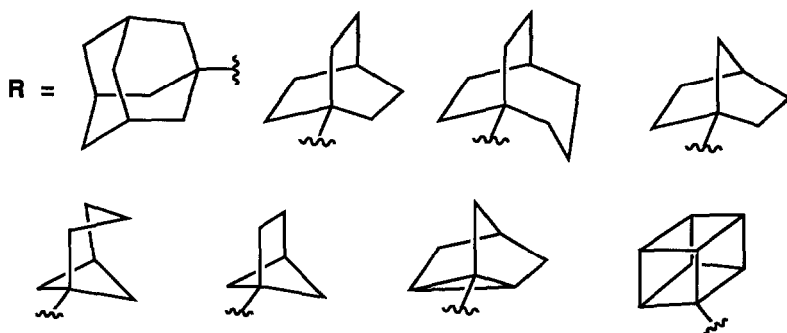
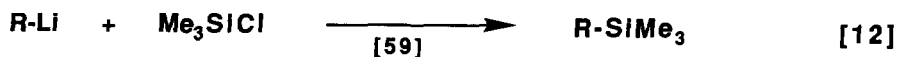

B. Reactions

The reaction of 1,1-dichloro- or cis or trans 1,2-dichloro- (or dibromo-)cyclohexane with tetramethylsilane in the presence of aluminum bromide gives 1,1-dimethylcyclohexane. (Eqn. 13)

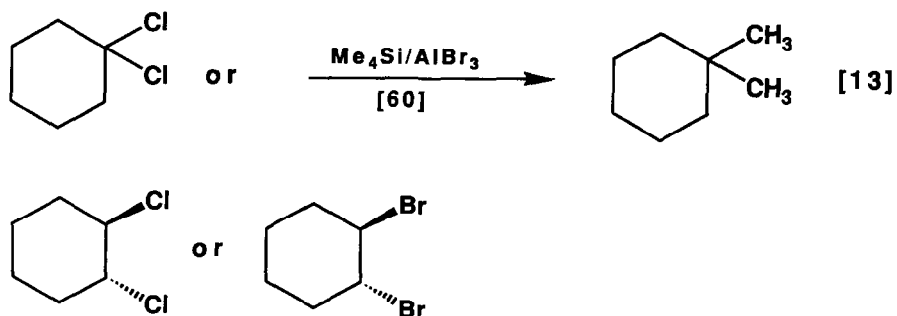

The reaction of tris(diethylamino)sulfur trimethyldifluorosilicate with aryl

iodides or aryl bromides in the presence of a palladium catalyst gives methylation of the aryl ring. (Eqn. 14)

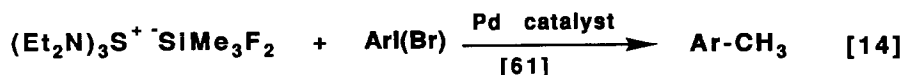

The reaction of 4-buten-1-yltrimethylsilane with cyclopropanoyl chloride gives cyclopropylmethyl cyclopropyl ketone. (Eqn. 15)

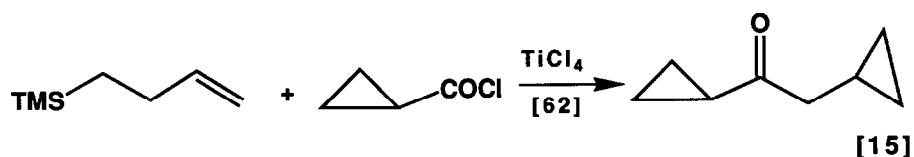

Double deprotonation of tert-butyl (meta-trifluoromethylphenyl)carbamate followed by trimethylsilylation provides **3** (Eqn. 16), deprotonation of which occurs at a methyl group of the trimethylsilyl group (Eqn. 17).

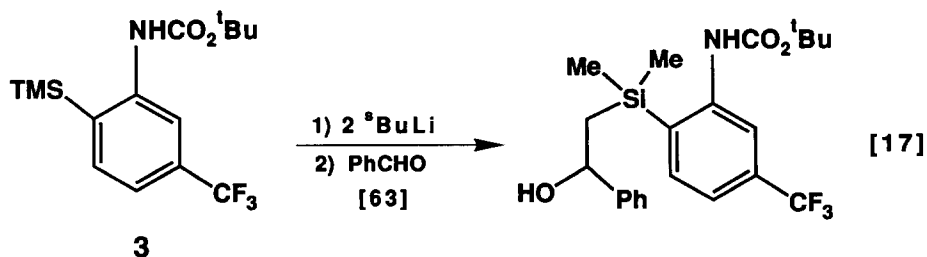
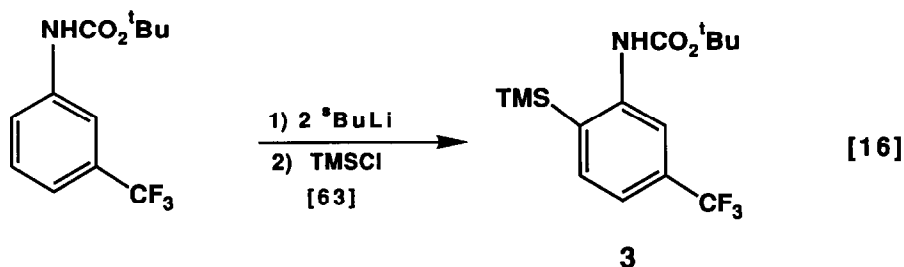

C. Other Studies

The MM2 force field has been extended to polysilanes, silanes, alkylsilanes and alkenylsilanes. [64] A force field (MM2) study of 1,2-di-tert-butyl and 1,2-disilyl-cyclohexanes has been reported. [65] The geometries of silacyclobutanes and silacyclobutenes was the subject of a theoretical study. Strain energies are predicted. [66] The structure and bonding of cycloalkanes and monosilacycloalkanes was analyzed by using the 3-21G* basis set and SCF wave functions. [67] Strain and structures for the silicon analogs of tetrahedrane, prismane and cubane was investigated. [68] The mechanism of the reaction of hydroxide and methoxide ion with tetramethylsilane in the gas phase was studied by ab initio calculations. [69] Tetramethylsilane was employed as a chemical ionization gas in chemical ionization mass spectrometry. [70]

V. ARYLSILANES

A. Preparation

The reaction of o-bis(dimethylchlorosilyl)benzene with sodium in toluene gives the cyclic disilane. (Eqn. 18)

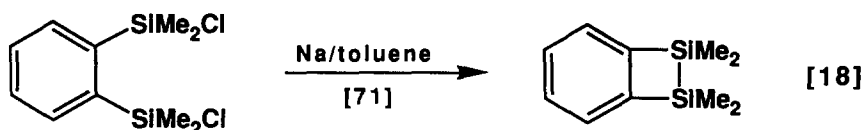

Tris(trimethylsilyl)methylsilanes were reacted with aryllithium reagents to give the aryl substituted trisil systems. (Eqn. 19)

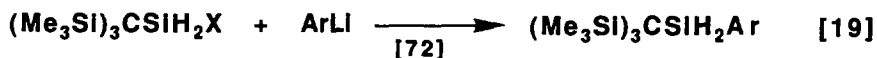

X = H, I, F; X = I or F react in 60 - 98% yield; X = H in 0 - 85% yield.

The reaction of 9,10-dibromoanthracene first with butyllithium and then with trimethylchlorosilane gives the bis(trimethylsilyl) derivative. (Eqn. 20)

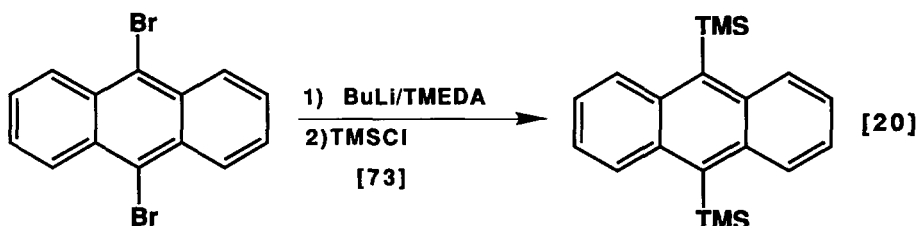

1,3,5-tris(trifluoromethyl)benzene was deprotonated and trimethylsilylated to give the bis(trimethylsilyl) derivative in moderate yield. (Eqn. 21)

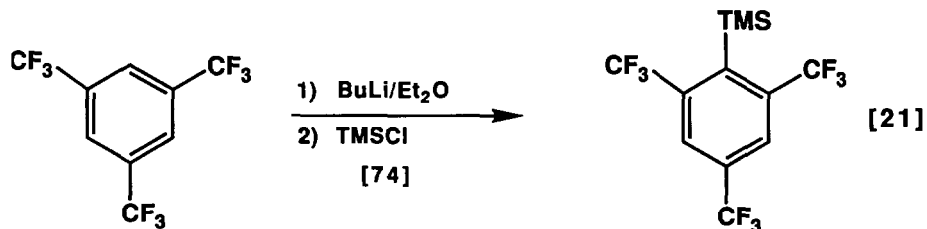

Deprotonation of 3-siloxymethylfurans and thiophenes results in deprotonation of the 2-position with subsequent migration of the silyl group from oxygen to carbon. (Eqns. 22 and 23)

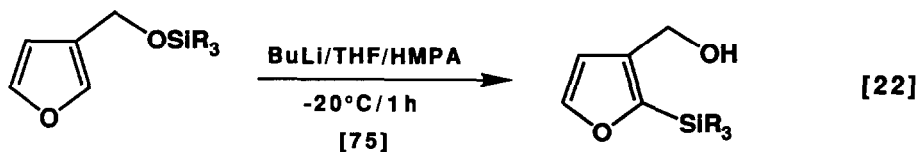

$\text{R}_3\text{Si} = \text{}^t\text{BuMe}_2\text{Si}, \text{}^i\text{Pr}_3\text{Si}, \text{}^i\text{BuPh}_2\text{Si}, \text{}^i\text{PrMe}_2\text{Si}, \text{PhMe}_2\text{Si}$ (24-87%)

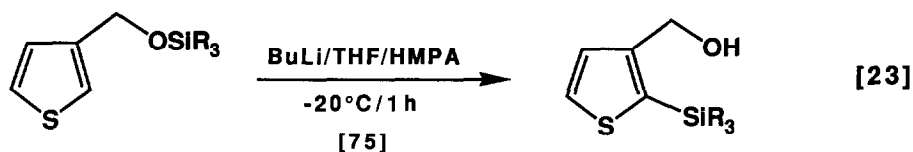

$R_3Si = {}^tBuMe_2Si, {}^iPr_3Si, {}^tBuPh_2Si, {}^iPrMe_2Si, Ph_2MeSi, PhMe_2Si$ (29-89%)

The (trimethylsilyl)thiazoles 4-8 were prepared and studied. For example, 8 is selectively protodesilylated with hydrochloric acid at the 2-position. (Eqn. 24) Other reactions of these systems are given later.

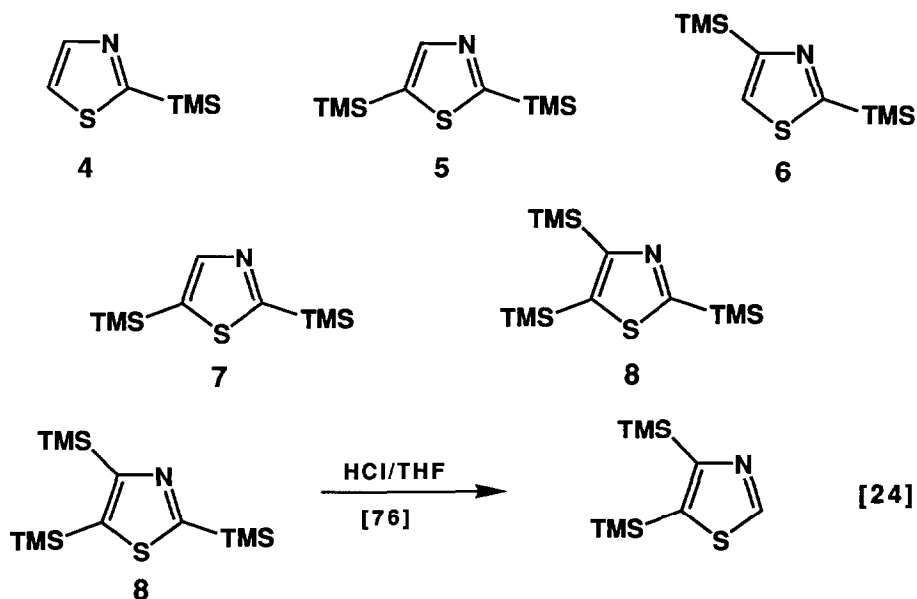

Lithium reagent 9 was nicely bis trimethylsilylated to give 10. (Eqn. 25)

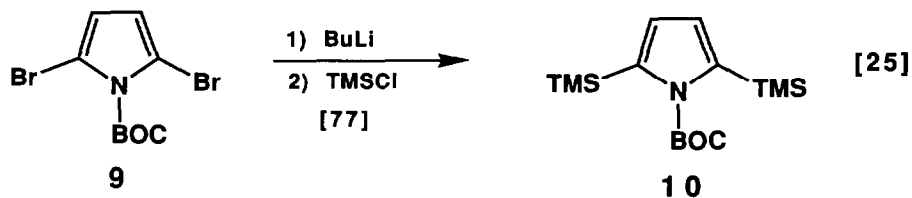

The lithiation of various bromopyridines followed by reaction with dimethyldichlorosilane was reported. (Eqn. 26) The resulting pyridyldimethylchlorosilanes were converted to the corresponding disiloxanes. (Eqn. 27) Oxidation to the pyridine oxides was also accomplished. (Eqn. 28)

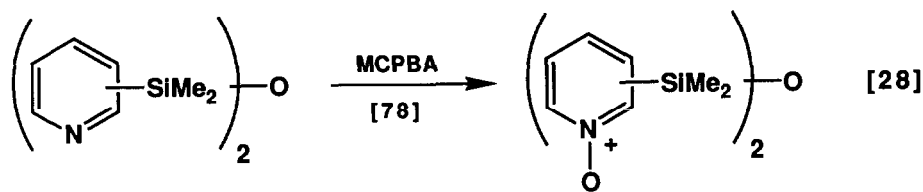
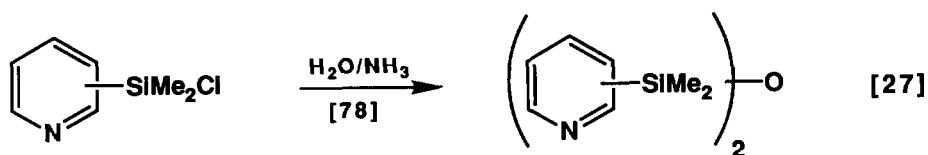
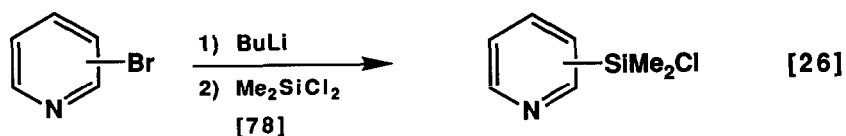

Double lithium-halogen exchange of **11** and then reaction with dimethyldichlorosilane gives **12**, which was investigated for its biological activity. (Eqn. 29)

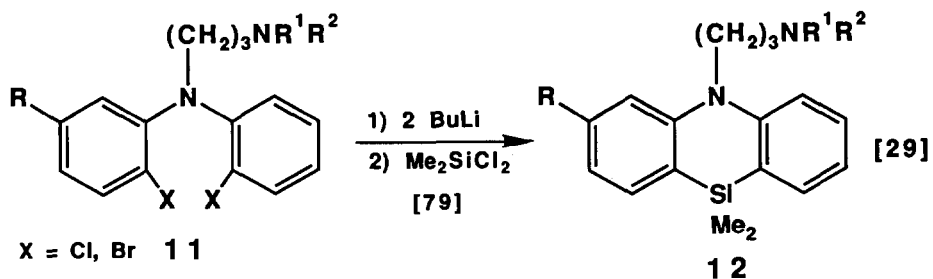

Hindered aryllithium reagents were reacted with bromotrichlorosilane to give trichlorosilyllithium and the bromoarene. (Eqn. 30)

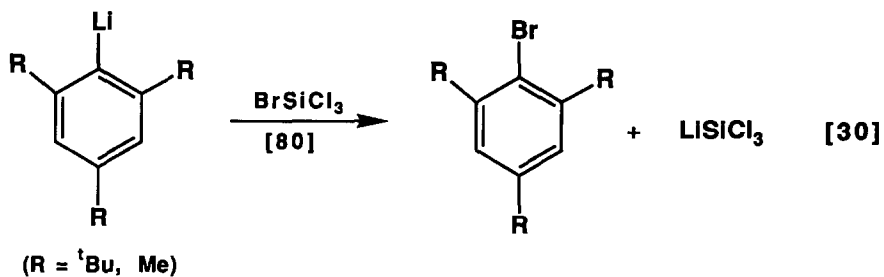

The tris trimethylsilylation of phenols was reported by treatment of the phenol with lithium metal and trimethylchlorosilane in tetrahydrofuran and then oxidation of the resulting dihydroarene. (Eqn. 31) A similar reaction occurs with anisoles. (Eqn 32)

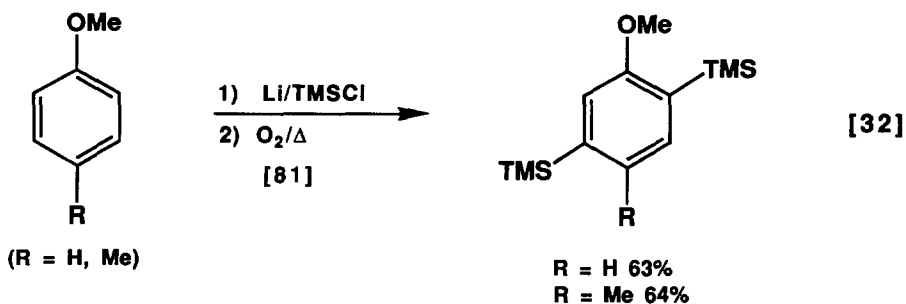
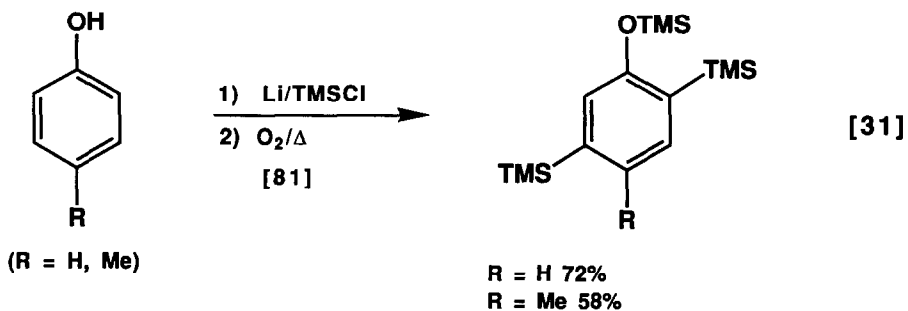

The reaction of arylmagnesium bromides with ethynylmethyl difluorosilane to give aryl(ethynyl)methyl fluorosilanes was reported. (Eqn. 33) The same products were also produced *via* reaction of ethynylmagnesium bromide with arylmethyl difluorosilanes. (Eqn. 34)

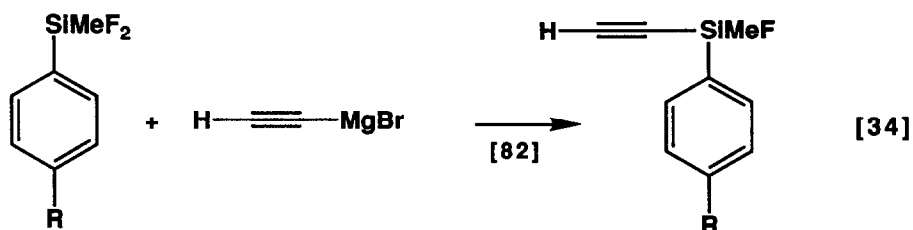
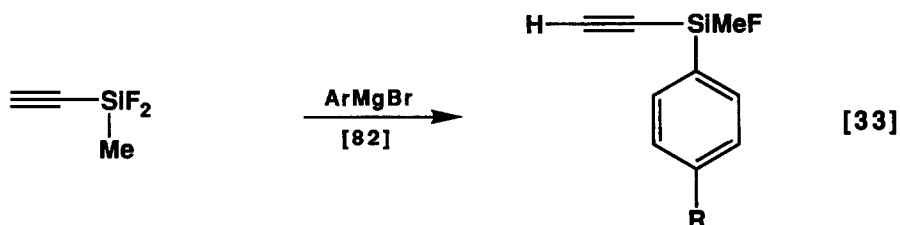

The reaction of pentachlorophenylmagnesium chloride with trichlorosilane gives tris(pentachlorophenyl)silane (Eqn. 35) This silane was converted to the chloride, bromide, and silanol with carbon tetrachloride/hv, bromine, and chlorine, respectively.

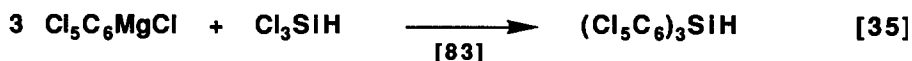

The 2-(α -chloroalkyl)furans are notably unstable. The presence of a 5-trimethylsilyl group, however, gives these materials added stability. This fact was employed in the utilization of the silylated versions in unfolding some of the chemistry of 2-(α -chloroalkyl)furans. (Eqns. 36-39)

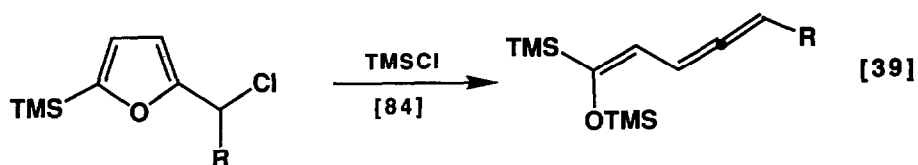
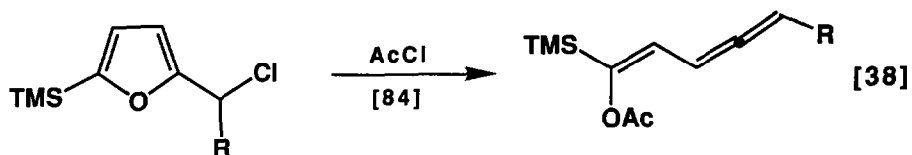
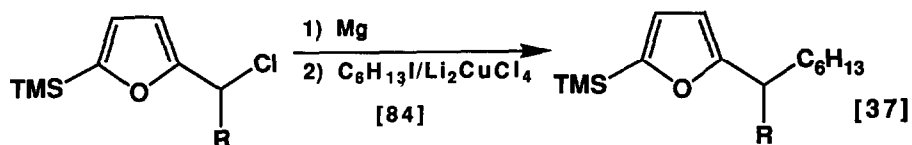
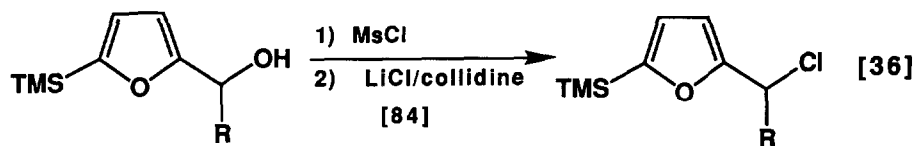

The diazonium salt **13** was reacted with ethynyltrimethylsilane to give the trimethylsilylated phenanthrene **14**. (Eqn. 40) A similar reaction was used to prepare the trimethylsilylated chrysene **15**. (Eqn. 41)

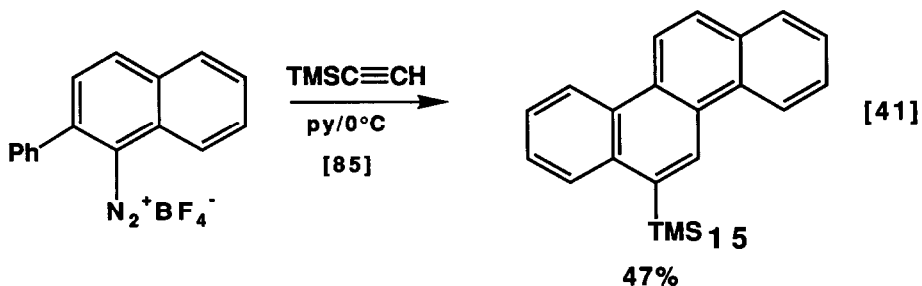
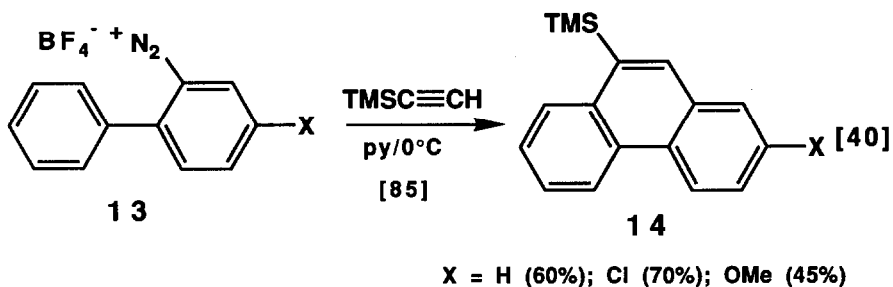

Aryl iodides were reacted with trimethylchlorosilane under electrolytic conditions to give the aryltrimethylsilane. (Eqn. 42)

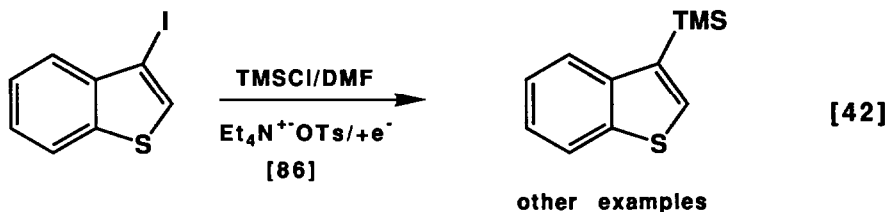

The reaction of 1-naphthylmethylchlorosilane with acetylene at high temperature gives the silaheterocycle **16**, whose X-ray crystal structure was determined. (Eqn. 43)

In an intramolecular reaction with an ethynylsilane **17** was thermally converted to **18**. (Eqn. 44)

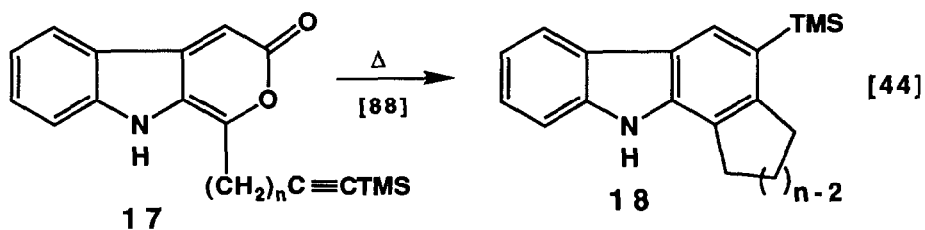
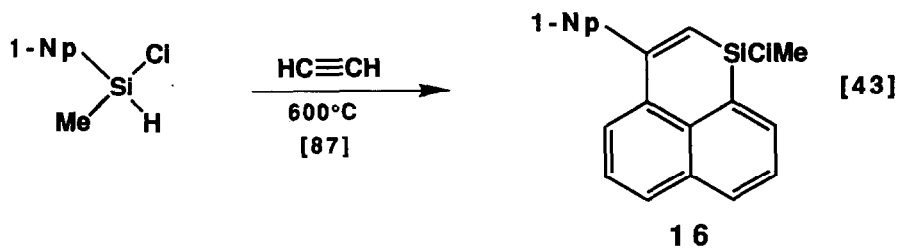

The reaction of toluene with triethylsilane in the presence of a rhodium(I) catalyst and light gives silylation of the aromatic ring as the major reaction pathway. (Eqn. 45) Benzene reacts with hexamethyldisilane under the same conditions to give phenyltrimethylsilane. (Eqn. 46)

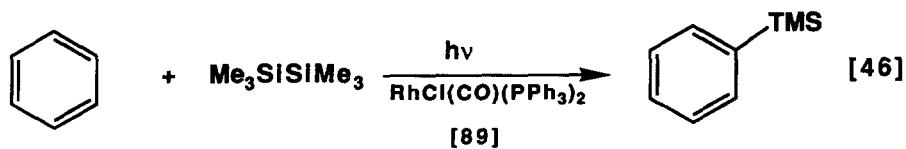
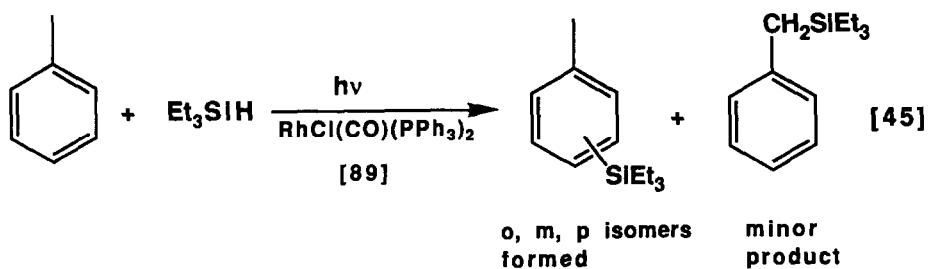

The photolysis of **19** in the presence of benzophenone gives the arylsilane **20** along with **21**. (Eqn. 47)

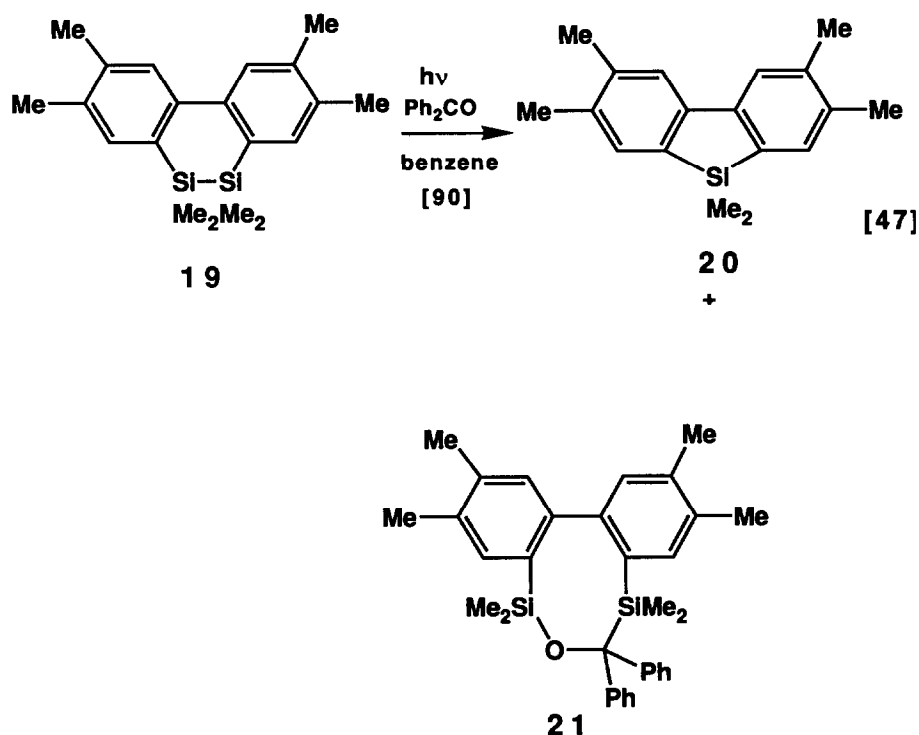

It was found that trimethylsilyl cation, generated in the gas phase reacts with benzene (Eqn. 48) and toluene (Eqn. 49). The para selectivity in the reaction with toluene is lower than that for tert-butyl cation with toluene.

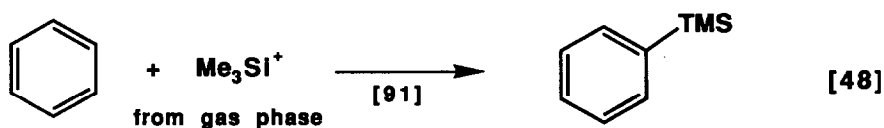

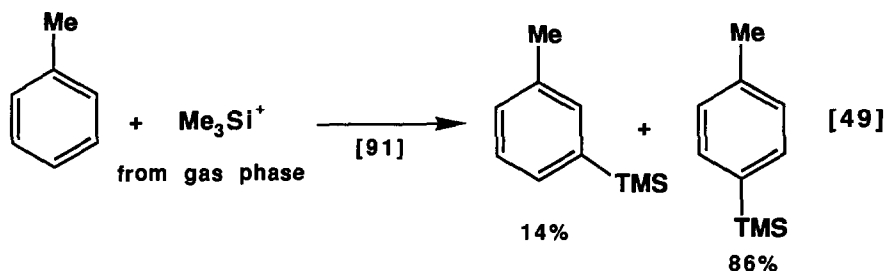

B. Reactions

A reexamination of the benzoylation of *m*-trimethylsilylanisole reveals that the methoxy group directs the site of benzoylation and not the trimethylsilyl group as previously reported. (Eqn. 50) The same is true for acylation.

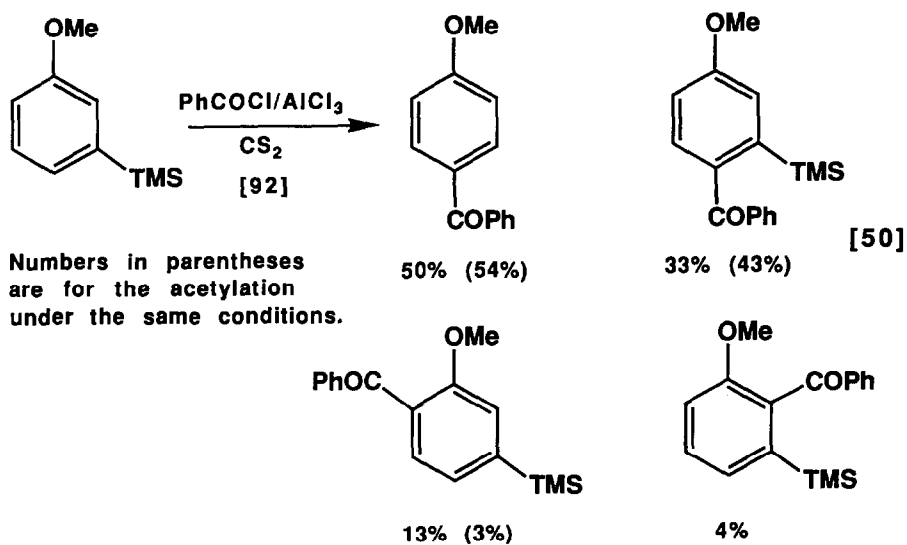

Aryltrimethylsilanes were reacted with dichloromethylmethyl ether in the presence of aluminum chloride to replace the trimethylsilyl group with an aldehyde group. (Eqn. 51)

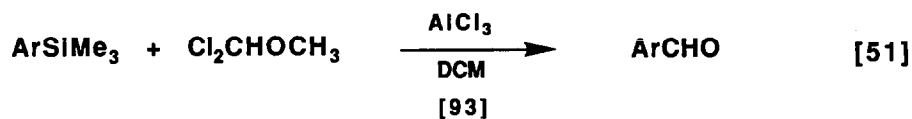

The acylation of **4** gives the 2-acyl derivative in a regiocontrolled reaction. (Eqn. 52)

With **6** the 2-trimethylsilyl group can be selectively removed by acylation. (Eqn. 53)

Compound **6a** was cleanly acylated. (Eqn. 54) It also reacted nicely with dimethyl

succinate. (Eqn. 55) Both **4** and **6a** were reacted with aldehydes under fluoride

mediation. (Eqns. 56 and 57) Finally, **4** and **6b** were reacted with ketenes to give

initially enol silyl ethers, which upon hydrolysis gives the ketone. (Eqns. 58 and 59)

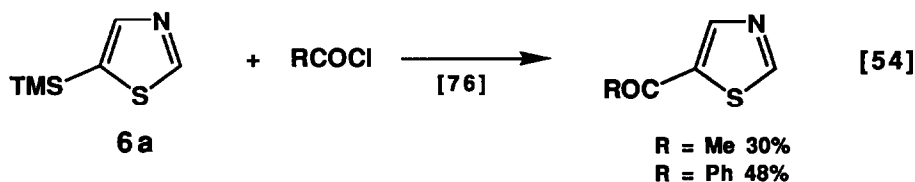
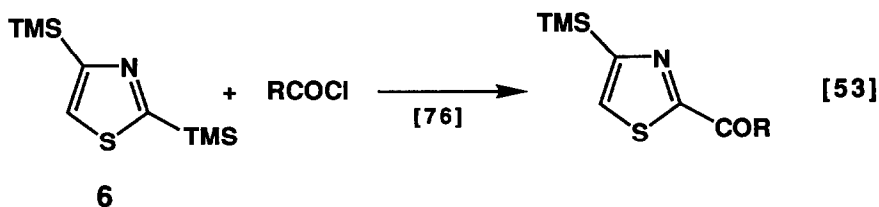
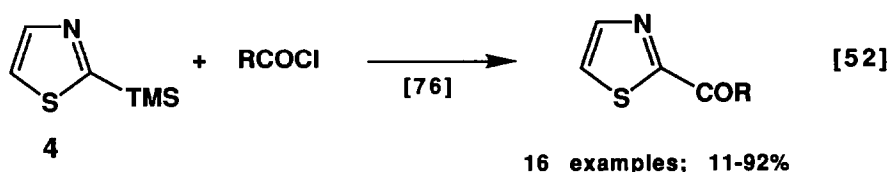

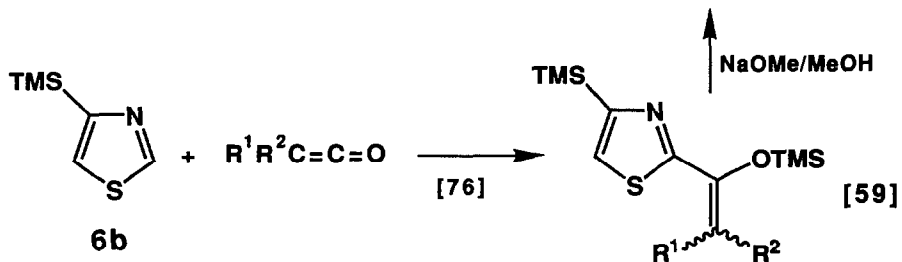
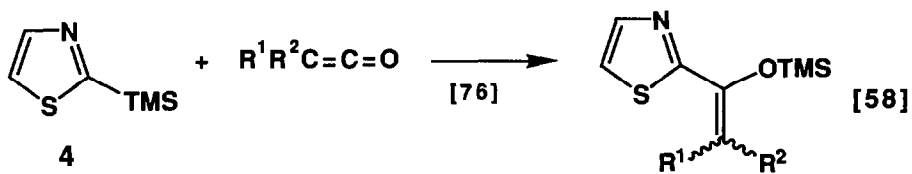
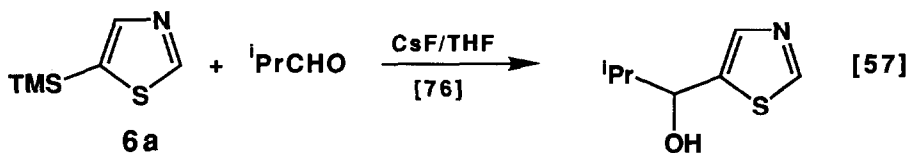
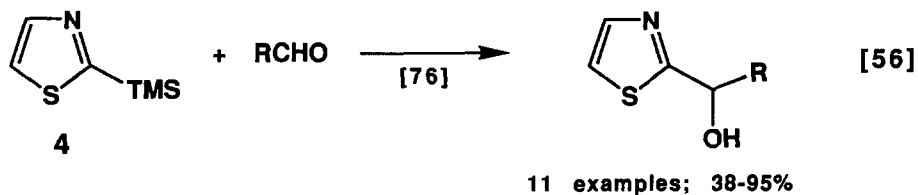
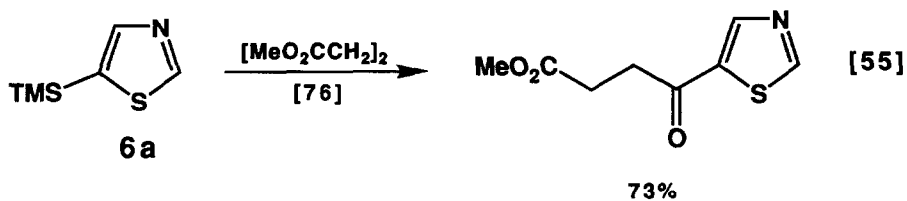

The bis(trimethylsilylated) anisole **22** is brominated at the ortho trimethylsilyl position with N-bromosuccinimide. (Eqn. 60) Bromine, on the other hand gives the 2,4-dibromo derivative (Eqn. 61) and acylation gives the 4-acyl product (Eqn. 62).

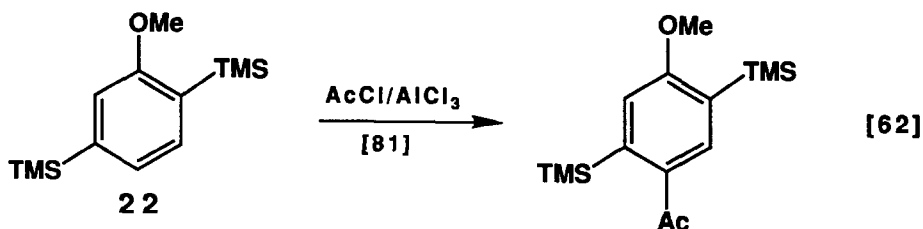
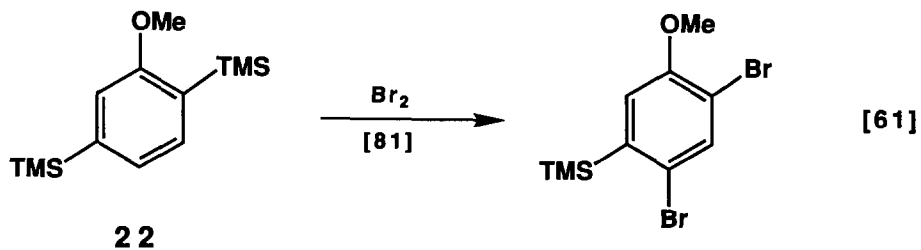
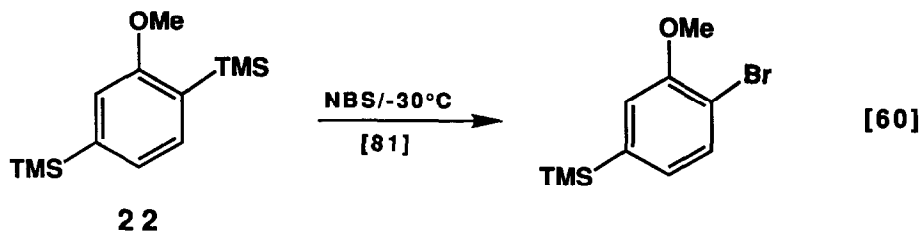

Reaction of **23** with boron tribromide and then hydrolysis gives the boronic acid **24** in what is an electrophilic cleavage of the aryl-silicon bond. (Eqn. 63) These aryl boronic acids were used to introduce other aryl groups onto the ring in a regiocontrolled process.

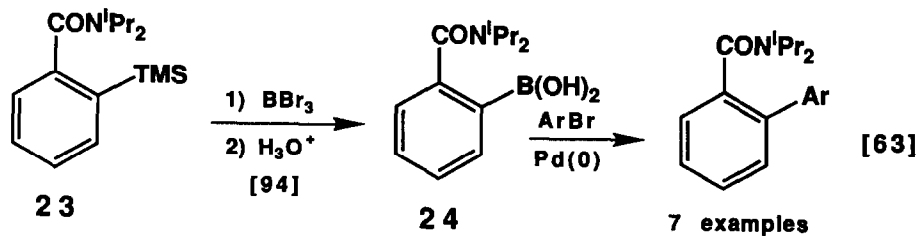

The direct oxidation of a carbon-silicon bond requires the presence of a leaving group on the silicon. This fact can somewhat limit the range of reaction conditions, solvents and the like that the organosilane can tolerate. This can be overcome with the use of a phenyldimethylsilyl group wherein the phenyl group plays the role of a stable, latent leaving group. Whereas in the past the phenyl group had to be cleaved in a separate step prior to the oxidation, two single-step procedures for this useful oxidation have now been reported. (Eqns. 64 and 65)

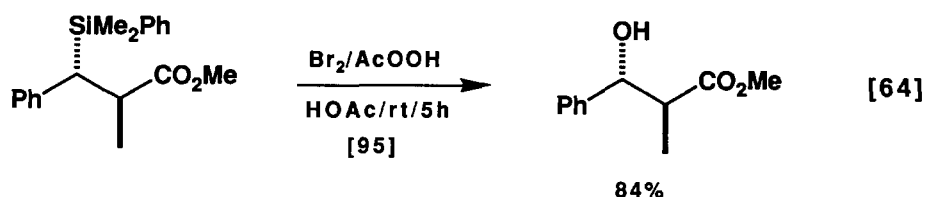

or $\text{Hg}(\text{OAc})_2/\text{AcOOH}/\text{HOAc}/\text{rt}/3\text{h}$ in 88%

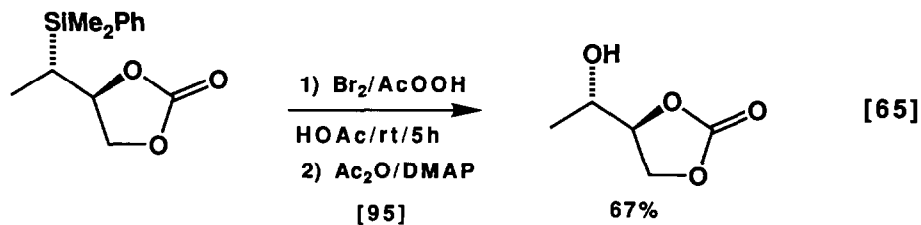

The silicon-modified metal-ammonia reduction of aromatic systems has been reported. Thus 1-trimethylsilylnaphthalene is reduced on the trimethylsilyl substituted ring. (Eqn. 66) The resulting allylsilane can be protodesilylated with or without double bond conjugation. The trimethylsilyl group competes well with a methyl group in the orientation of the reduction as well. (Eqn. 67)

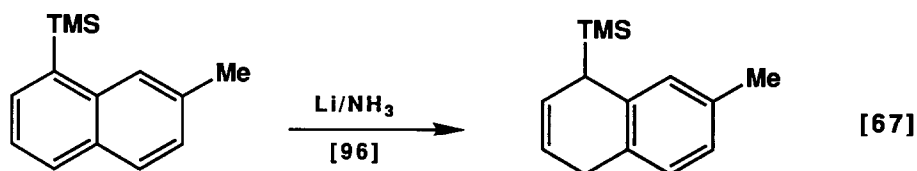
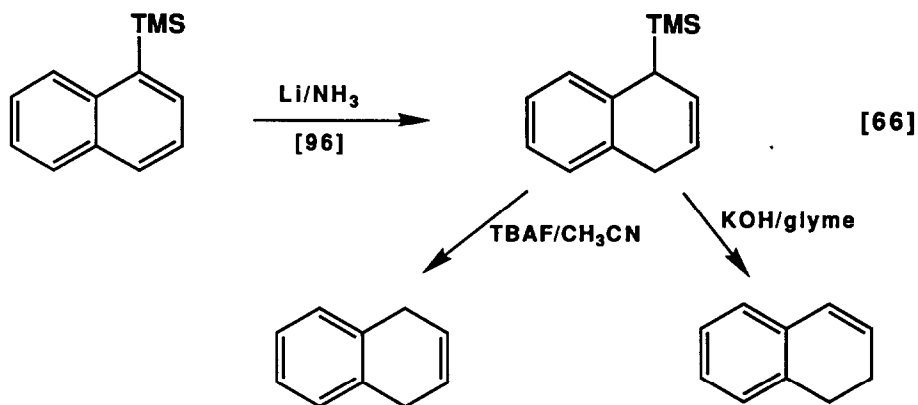

The tert-butyldimethylsilyl group on the 2-position of 3-hydroxymethyl furans allows the selective electrophilic substitution, *via* the lithium reagent, of the 4-position. The silyl group is conveniently removed with fluoride ion. (Eqn. 68) The lithiation occurs more selectively at C-4 at lower temperatures.

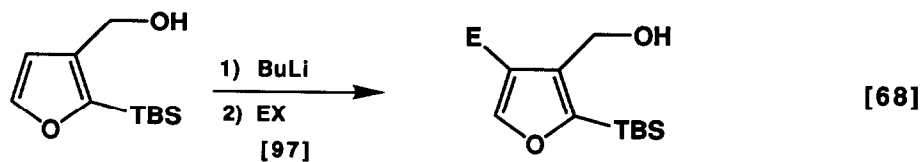

EX = MeOD, I₂, MeI, TMSCl, Cl(CH₂)₃I, ClCO₂Me, ClCONEt₂

Yields 57-95%

An intramolecular silyl-mediated cyclization was reported for compound **25**. (Eqn. 69) The trimethylsilyl group can be bromodesilylated. (Eqn. 70)

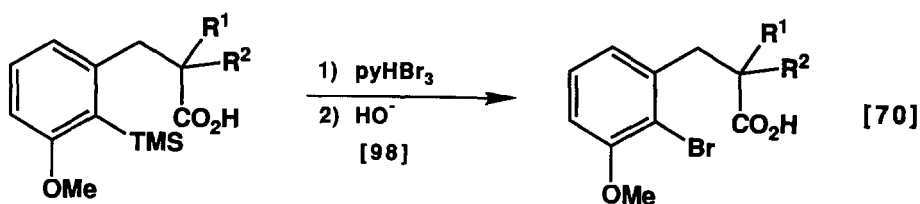
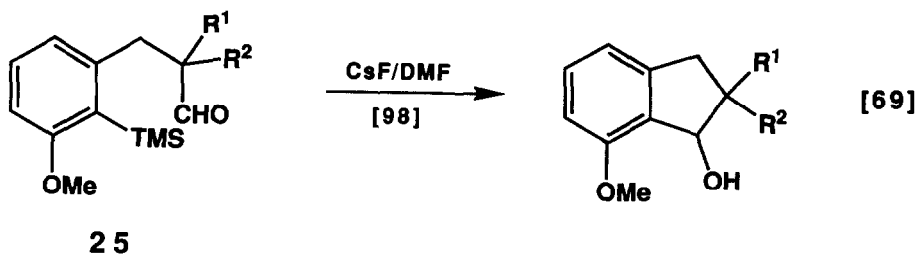

For both equations $R^1, R^2 = \text{H,H}; \text{H,Me}, \text{Me,Me}$

Treatment of **26** with silica gel at 200°C gives arylsilane **27**, which can be desilylated with tetra-*n*-butylammonium fluoride. (Eqn. 71)

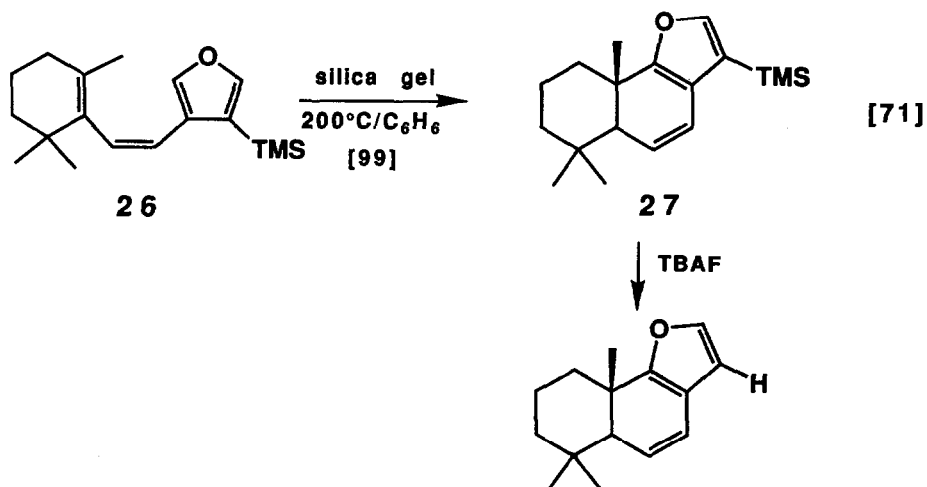

Pentafluorophenyltrimethylsilane is partially protodesilylated with piperidine in acetonitrile. (Eqn. 72) It, however, reacts with cleaner substitution at the para position with other nucleophiles. (Eqn. 73)

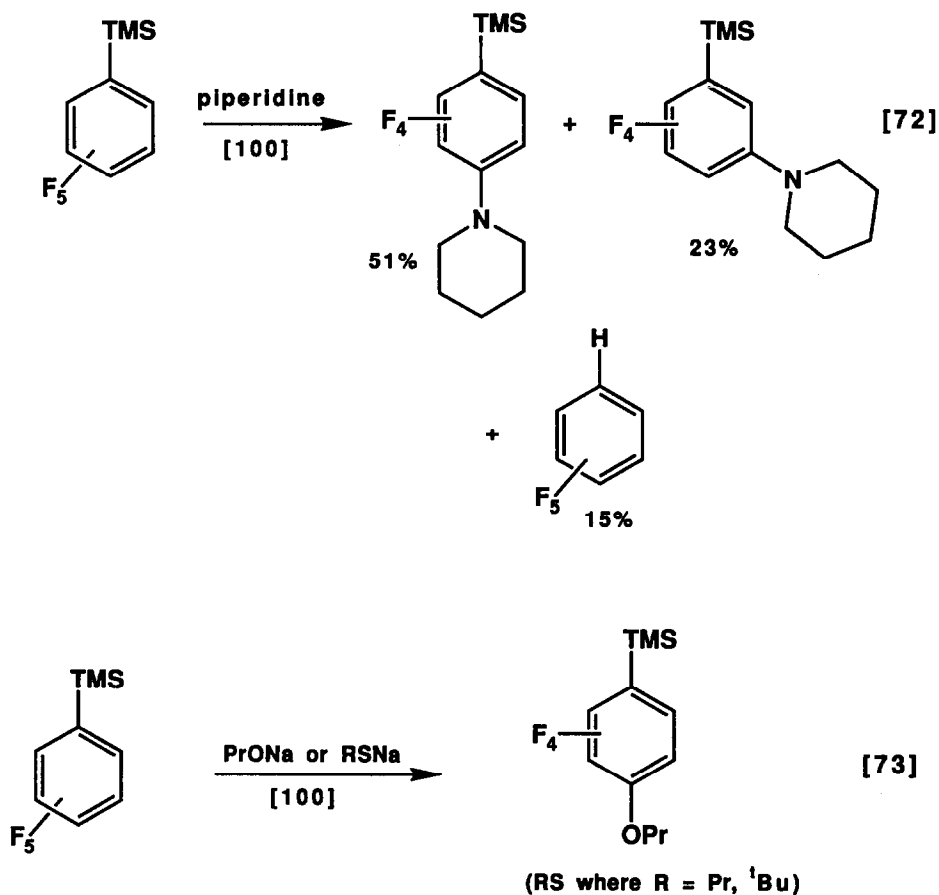

Thermolysis of **28** leads to **29** presumably *via* electrophilic substitution of the trimethylsilyl group and then electrophilic aromatic substitution. (Eqn. 74)

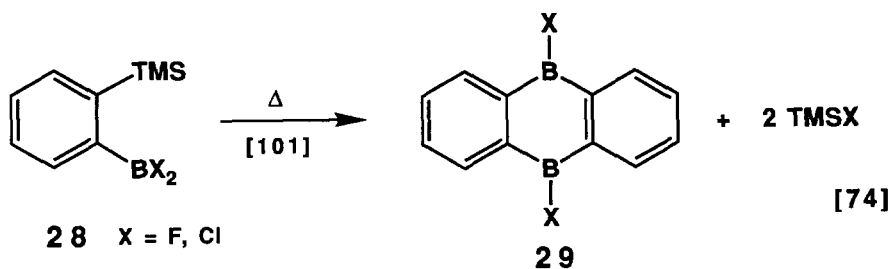

Oxidation of **30** leads to migration of the trimethylsilyl group and formation of

31. (Eqn. 75)

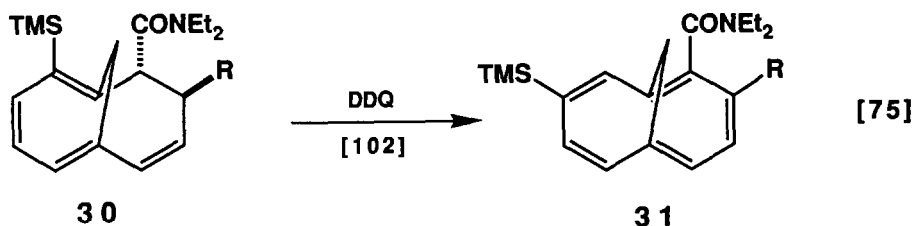

(R = Me, Ph)

C. Other Studies

The compounds 2-methylfuran, 2-tert-butylfuran and 2-trimethylsilylfuran were the subject of ultraviolet and photoelectron spectroscopy as well as CNDO calculations.

[103] The sigma-pi interactions in the [2.2]paracyclophanes **32**, **33** and **34** were studied by photoelectron spectroscopy. [104]

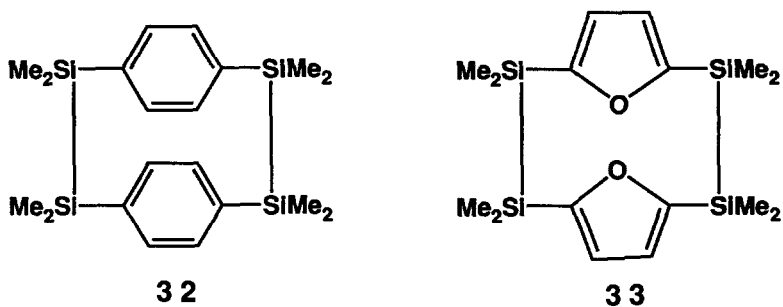

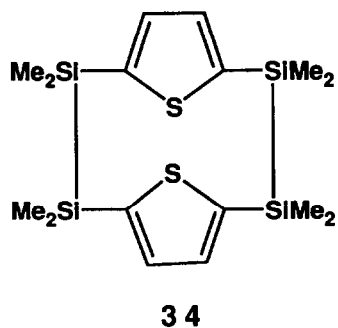

The molecular polarizability of various 2-furanyl- and 2-thiofuranylsilanes was investigated. [105]

A multinuclear NMR study of several trimethylsilylated indoles (**35 - 41**) was reported. [106] A dynamic NMR study of the hindered boat-boat interconversion of **42** was carried out. [107]

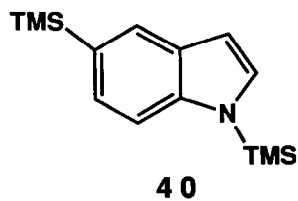
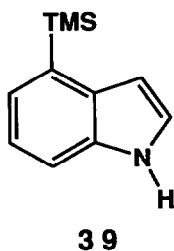
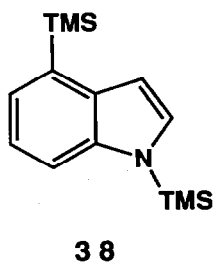
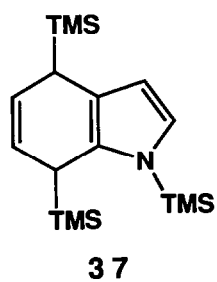
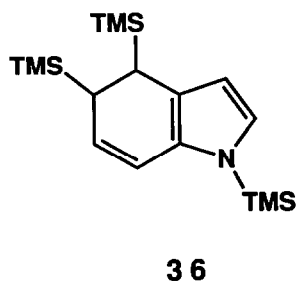
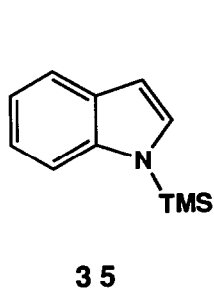

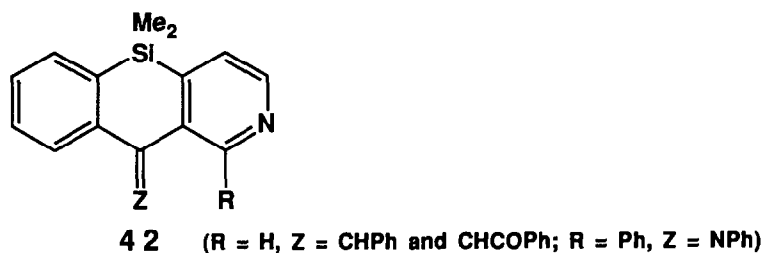
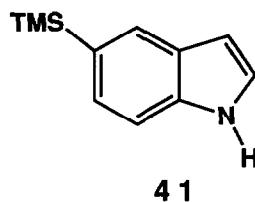

The partial rate factors for the protodetrification and protodesilylation of 1,6:8,13-propane-1,3-diylidene[14]annulene with tritium and trimethylsilyl substituents on the 2-position were measured. [108] In a similar study of the protodesilylation of 1,6-methano[10]annulenes **43** showed evidence for C-1 to C-6 transannular orbital interactions. [109] A kinetic study of the protodesilylation of silylated tricyclic benzocyclenes was reported. [110]

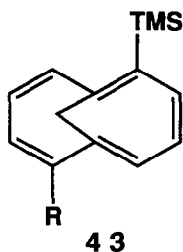

The optically active Lewis acids **44** and **45** were utilized in the catalysis of hetero-Diels-Alder reactions. Products with up to 87% enantiomeric excess were reported. [111]

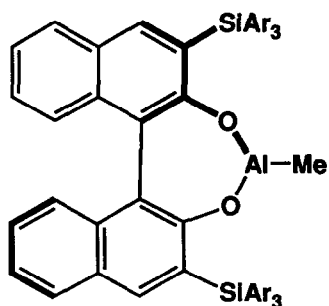

44

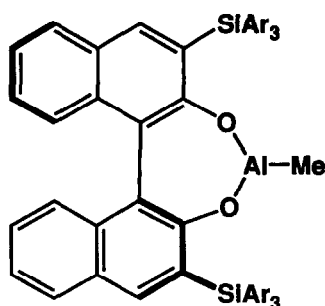

45

The silicon containing systems **46** [112], **47** [113], **48** [114], and **49** [115] were reported to show biological activity.

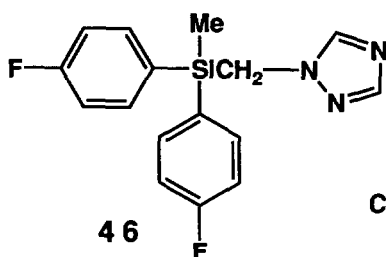

46

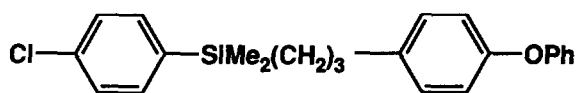

47

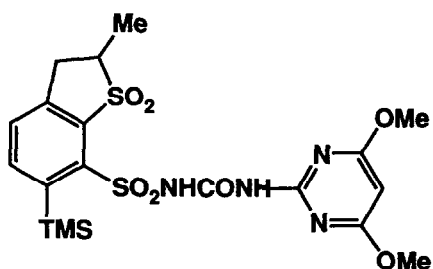

48

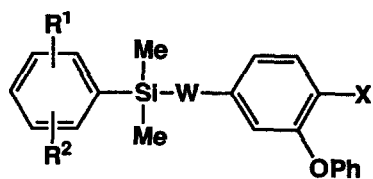

49

$\text{W} = (\text{CH}_2)_3, \text{CH}_2\text{OCH}_2$; $\text{X} = \text{H}, \text{F}$

VI. HYDROSILATION

A. New Developments

Several new catalysts were presented for the hydrosilation of multiple bonds. A platinum catalyst modified with amides was used for a more selective hydrosilation of styrene. Thus the common chloroplatinic acid catalyst modified with N,N-dimethylacetamide gave a $\beta:\alpha$ ratio of 90:10 versus a ratio of 60:40 without the amide modification. [116] Chloroplatinic acid modified with aminophosphazenes was used to hydrosilate vinyltriethoxysilane with triethoxysilane. [117] Cis-dichlorobis(styrene)-platinum(II) in the presence of aniline or pyridine was employed in the hydrosilation of olefins, acetylenes and carbonyls. [118] The hydrosilation of transition metal complexes with aminophosphine ligands fixed to polystyrene or free were used in the hydrosilation of olefins and carbonyls. [119] Thiourea complexes of Platinum(II) and palladium (II) were used in the hydrosilation of 1-hexene and phenylacetylene. [120] Various quaternary onium chlorometalates of transition metals were investigated as hydrosilation catalysts for the reaction of triethylsilane with phenylacetylene. [121] Some of the materials were anchored onto polymers. The gas phase hydrosilation of acetylene with trichlorosilane on functionalized silica supported rhodium and ruthenium phosphine catalysts was reported. [122] The hydrosilation of 1-octene, 1-pentyne and 1-hexyne was carried out with triethylsilane, triethoxysilane and trimethoxysilane using silica-supported allylplatinum-, nickel, and rhodium catalysts. [123] Diaminofunctional dialkoxy (or dichloro) silanes were grafted onto chrysotile asbestos and then transition metal complexes reacted with the resulting amino functionalized material to give a hydrosilation catalyst. [124]

B. Hydrosilation of Alkenes

Trichlorosilane was reacted with 1,3-cyclohexadiene and chloroplatinic acid and

then ethanol to give bis-1,3(triethoxysilyl)cyclohexane. This was treated with four equivalents of methylmagnesium bromide and finally water to give the cyclic siloxane 50. (Eqns. 76 and 77)

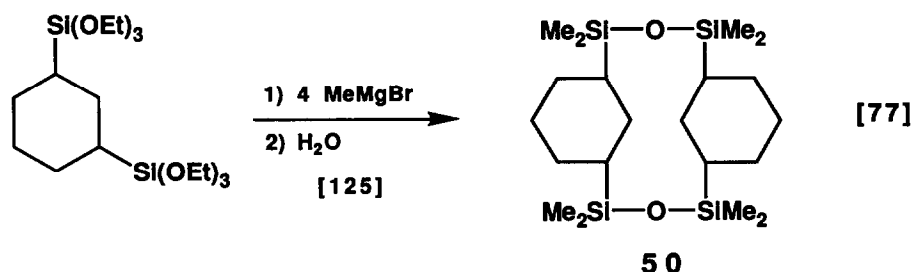
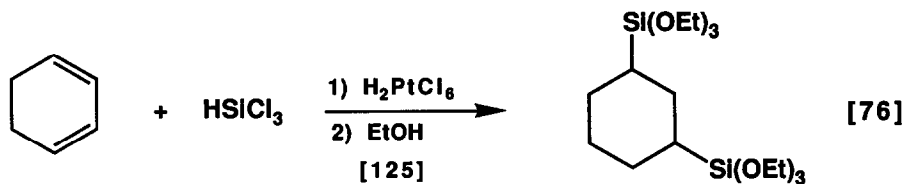

The hydrosilation of 1,1,1-trichloro-4-pentene with triethylsilane gave 1,1,1-trichloro-5-triethylsilylpentane. (Eqn. 78) On the other hand the same reaction with 1,1,1-trichloropropene gave 1,1-dichloropropene, 1,1,1-trichloropropane, cis and trans-1-triethylsilyl-1-chloropropene and bis(triethylsilyl)propane. (Eqn. 79)

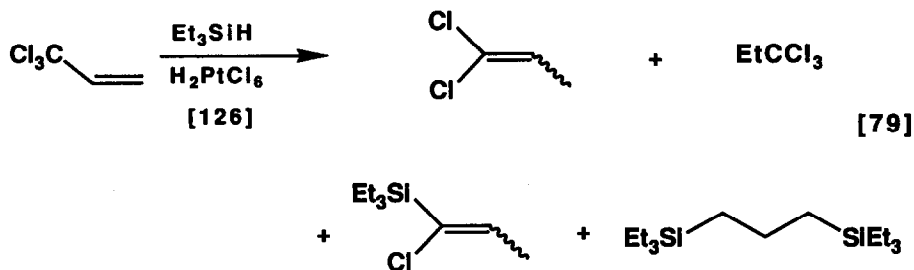
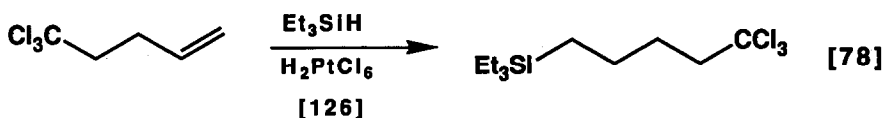

The hydrosilation of tricyclo[5.2.1.0^{2,4}]deca-3,8-diene was reported to be highly regioselective when catalyzed by cobalt and rhodium carbonyl complexes. (Eqn. 80)

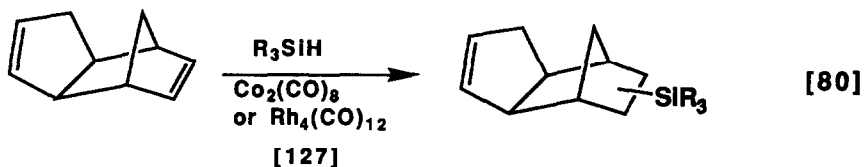

(R₃Si = combinations of Me, OEt, Cl and BuO)

The hydrosilation of 2-methyl-1-buten-3-yne with methylchlorosilane was shown to improve in the presence of added chlorosilanes. (Eqns. 81 and 82)

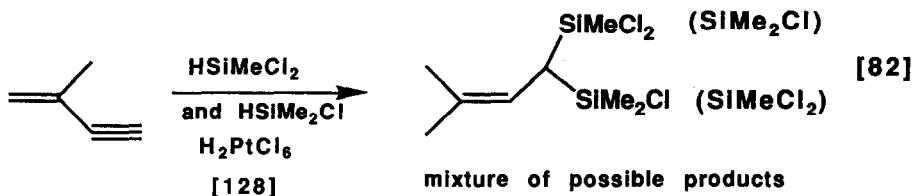
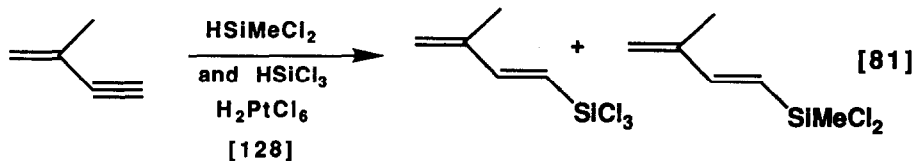

The hydrosilation of the allyl crown ether **51** was carried out with the resulting product **52** having the ability to be attached to silica surfaces. (Eqn. 83)

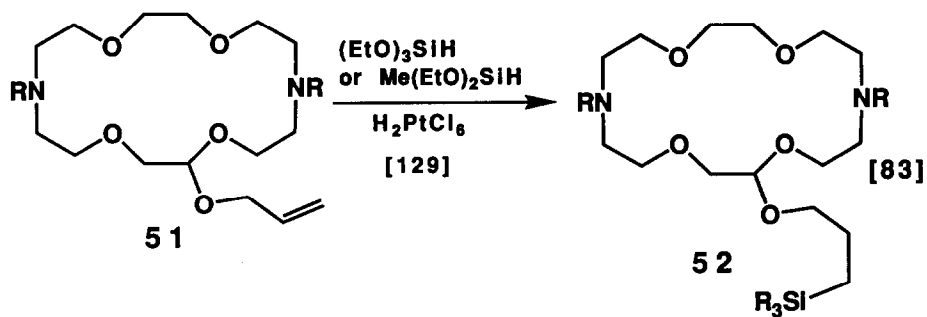

An intramolecular hydrosilation followed by oxidation of the silicon-carbon bond was used to prepare 1,2,3-triol derivatives of fixed stereochemistry. (Eqns. 84 and 85)

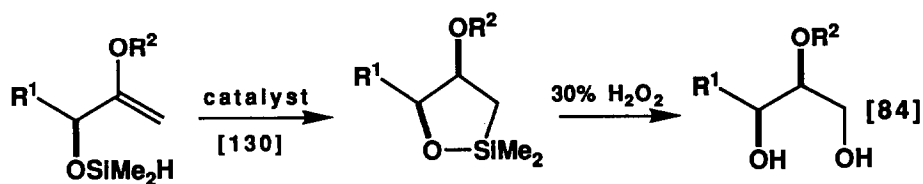

catalysts were Pt(0) and Rh(I) complexes

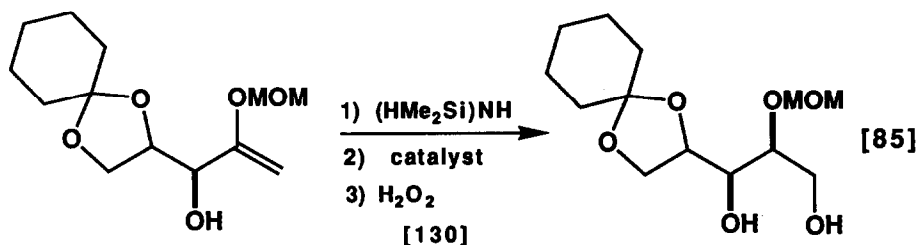

An intramolecular hydrosilation of **53** was reported. (Eqn. 86)

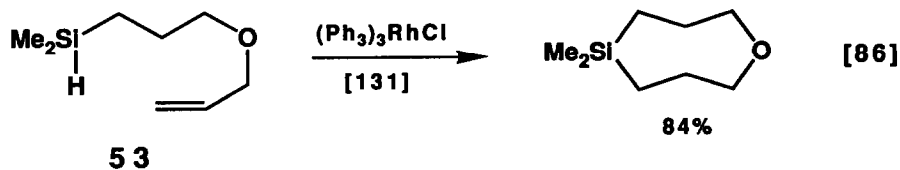

C. Hydrosilation of Alkynes

1-Triethylsilyl-1-hexyne was prepared via the hydrosilation of 1-hexyne with an iridium catalyst. (Eqn. 87)

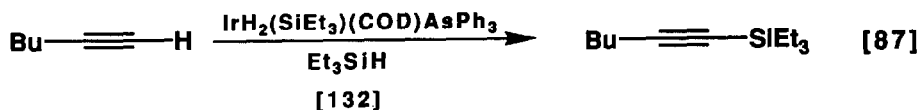

The hydrosilation of terminal alkynes was carried out with dialkyl(anilino)-silanes and chloroplatinic acid. (Eqn. 88)

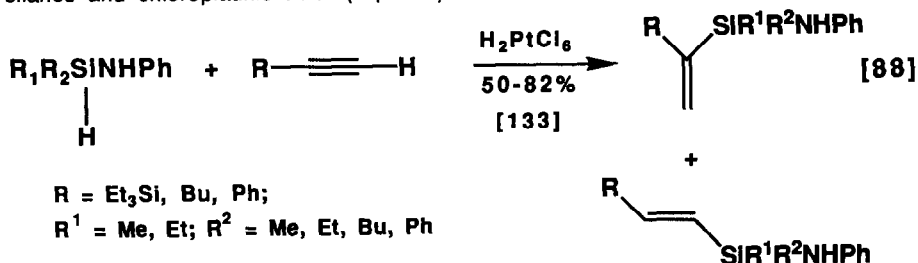

The mono hydrosilation of **54** was carried out with triethylsilane. (Eqn. 89) The reactions of the products were studied.

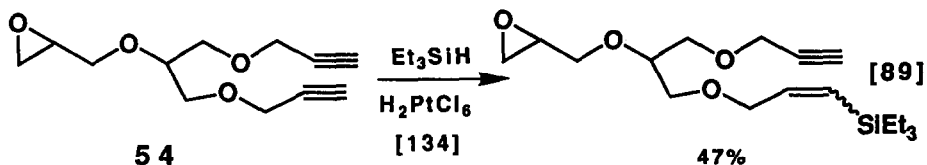

The hydrosilation of the enyne **55** gave chemoselective, but nonregioselective hydrosilation of the triple bond. (Eqn. 90)

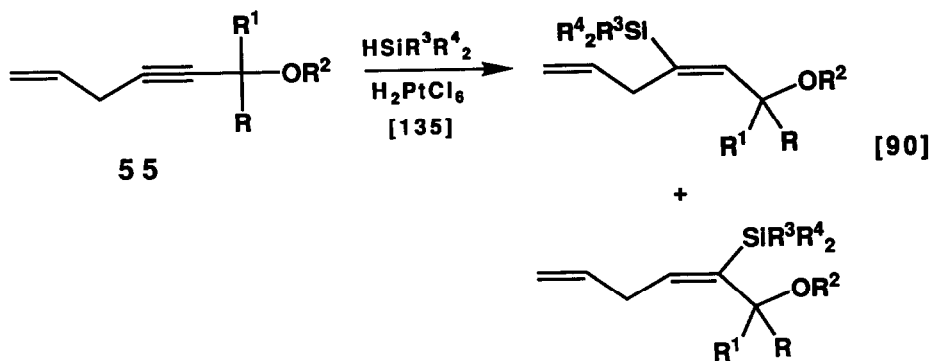

D. Hydrosilation-Reductions

The mechanism of the addition of the Si-H bond to carbonyls to form silyl enol ethers and silyl ethers was studied. (Eqn. 91)

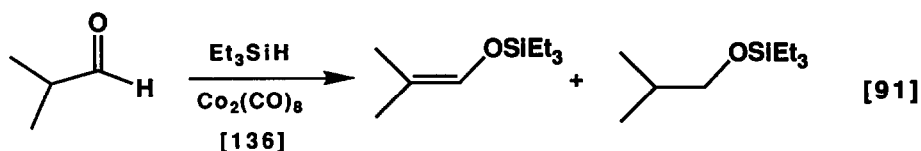

The hydrosilation of the cyclic imine **56** with diphenylsilane in the presence of a rhodium catalyst and optically active phosphine ligands gave the N-silylated product in up to 66% enantiomeric excess. (Eqn. 92)

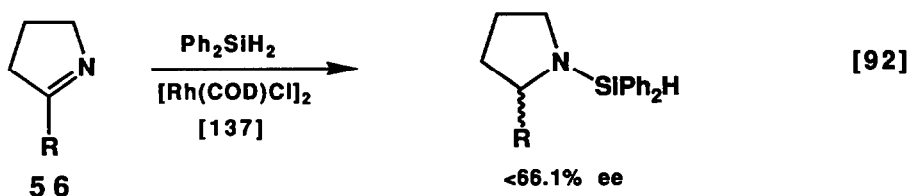

The hydrosilation of prochiral ketones with a catalyst prepared from soluble

(bicyclo[2.2.1]hepta-2,5-diene)rhodium(I) complexes containing enantiomers of 1,2-phenylenebis(methylphenylarsine) and the phosphorus isosteres was studied. (Eqn. 93) Optical yields were in the range of 18-41%.

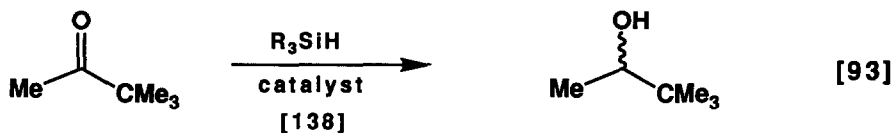

VII. VINYLSILANES

A. Preparation

Trans-2-trimethylsilylvinyl lithium was reacted with cyclobutanone **57** to give the corresponding allyl alcohol **58**, which is at the same time a vinylsilane. (Eqn. 94)

The E isomer of the vinylsilane **58** can be thermally rearranged to the cyclooctanone **59**. (Eqn. 95)

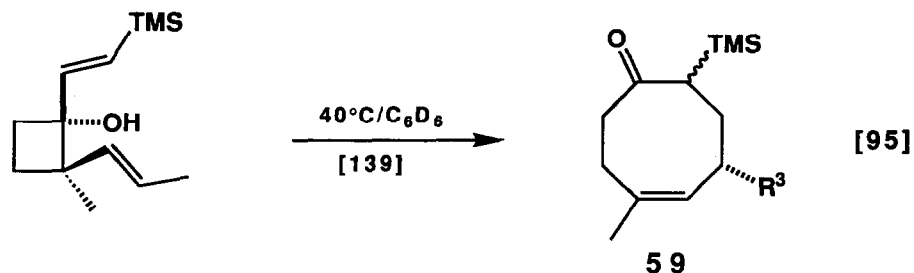
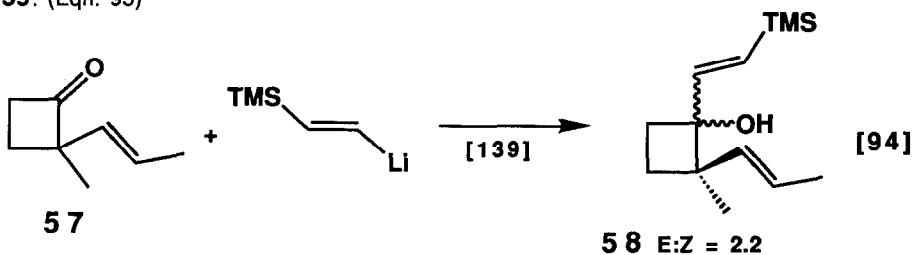

The reaction of the sulfone acetal **60** with 2 equivalents of butyllithium gives the vinyl lithium reagent, which was reacted with trimethylchlorosilane to give **61** in

good yield. (Eqn. 96) In a similar reaction **62** was converted to **63**. (Eqn. 97)

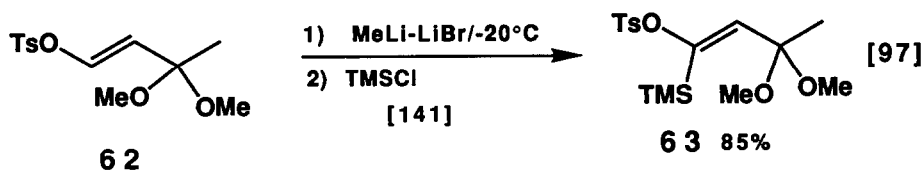
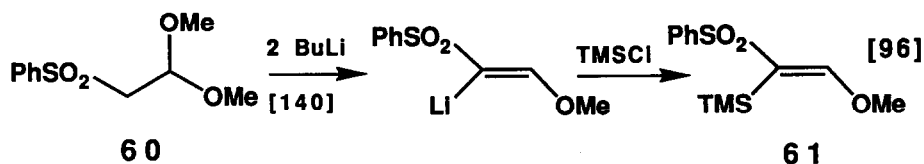

Metal-halogen exchange of **64** and then trimethylsilylation gave a cis/trans mixture of the corresponding vinylsilanes. (Eqn. 98)

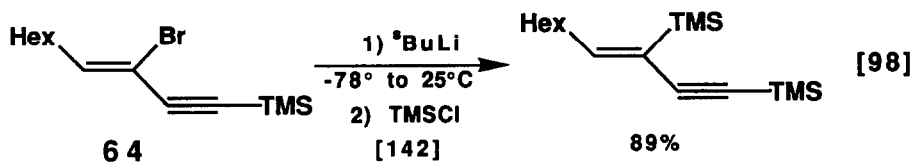

Metal-metal exchange of systems of the general structure **65** followed by trimethylsilylation gives the α -stannylvinylsilane. (Eqn. 99) The same is true for the diplumbyl system **66**. (Eqn. 100)



($\text{R}^1, \text{R}^2 = \text{Me, Me; EtOCH}_2, \text{Me; MeOMe, Me; Ph, Ph; 1-methoxycyclohexyl, H}$):
 Yields 46-73%



($\text{R}^1, \text{R}^2 = \text{H}, \text{H}; \text{MeOCH}_2, \text{MeOCH}_2; \text{Ph}, \text{Ph}$): Yields 56-82%

The reaction of trimethylsilylmethylmagnesium chloride with dithioacetals in the presence of nickel(II) provides vinylsilanes in good yields. (Eqns. 101 and 102)

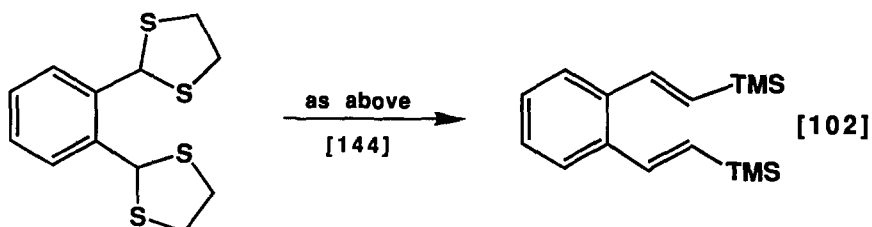
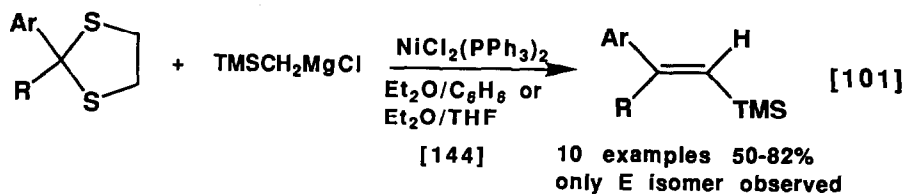

The reaction of α, α -dibromomethyltrimethylsilane with aldehydes in the presence of chromium(II) chloride results in vinylsilanes. (Eqn. 103) The active reagent is prepared from the reduction of the α, α -dibromomethyltrimethylsilane and chromium(II) chloride.



8 examples: 72-86%: E isomers only

Epoxy silanes were reacted with isopropylmagnesium or tert-butylmagnesium reagents in the presence of cuprous cyanide to give vinylsilanes via desoxygenation.

(Eqn. 104)

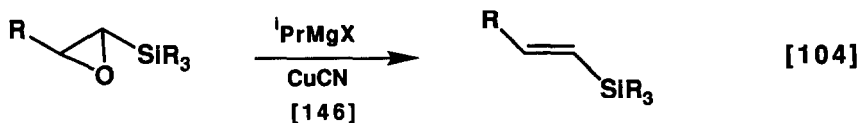

(R₃Si must contain one alkoxy group; isopropoxydimethylsilyl worked well)

Lithium bis(phenyldimethylsilyl)cuprate was shown to add to propargyl acetates or, better, propargyl carbamates to give allenylsilanes in good yields. (Eqns. 105 and 106) Alternatively, a silylated propargyl sulfonate or bromide can be treated with a cuprate to give allenylsilanes. (Eqns. 107 and 108) Finally, treatment of an allenyl bromide with silyl copper reagent gives the allenylsilane as well. (Eqn. 109)

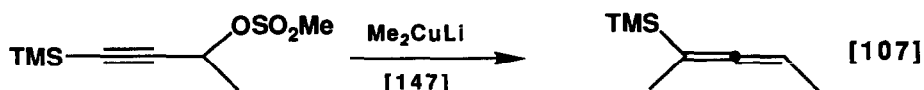
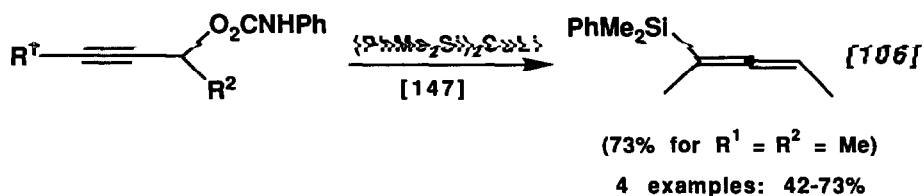
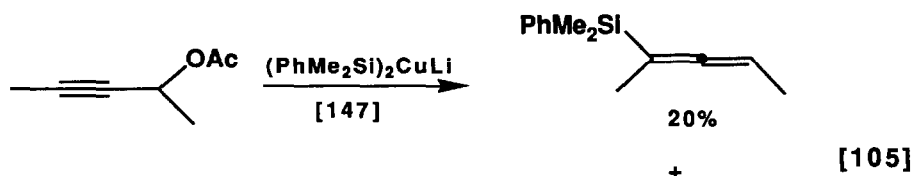

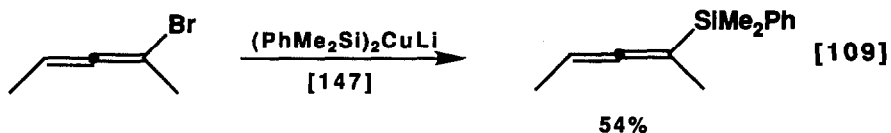
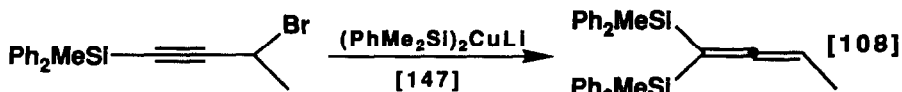

The reaction of vinyl halides with [tris(silyl)manganese]methylmagnesium produces vinylsilanes. (Eqn. 110)

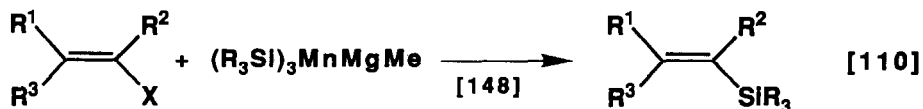

($\text{R}_3\text{Si} = \text{PhMe}_2\text{Si}$ 16 examples: 40-100%)

($\text{R}_3\text{Si} = \text{Me}_3\text{Si}$ 3 examples: 89-100%)

X = Br, I, SMe, OP(O)Ph₂, OSO₂CF₃, SPh

The reaction of vinyl halides with "trimethylsilyl anion", generated from the reaction of hexamethyldisilane and tris(dimethylamino)sulfur trimethylsilyl difluoride (TAS-F), in the presence of palladium(0) gives vinylsilanes. (Eqn. 111) This reaction also works for the preparation of arylsilanes.

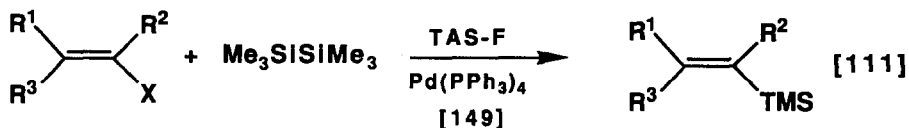

Deprotonation of chloromethyltrimethylsilane followed by condensation with a ketone or aldehyde gives vinylsilanes when the resulting initial β -oxido chloride is treated with lithium naphthalenide. (Eqn. 112)

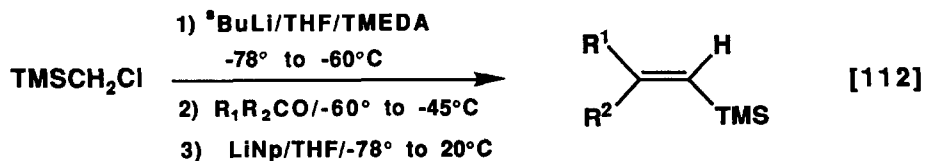

8 examples: 46-61% mostly E isomer

The hydroboration of alkoxyethynylsilanes followed by protodeboronation gives cis β -trimethylsilyl enol ethers. (Eqn. 113)

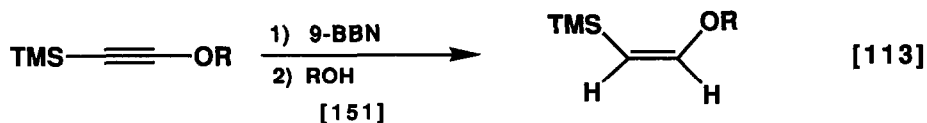

The reaction of various organometallic reagents with ethynylsilanes was useful for the preparation of vinylsilanes. The allylzinc reagent **67** was reacted with ethynylsilanes to give the expected addition to the triple bond. Cyclization of the resulting vinylzinc reagent with the allyl ether gave **68**. (Eqn. 114)

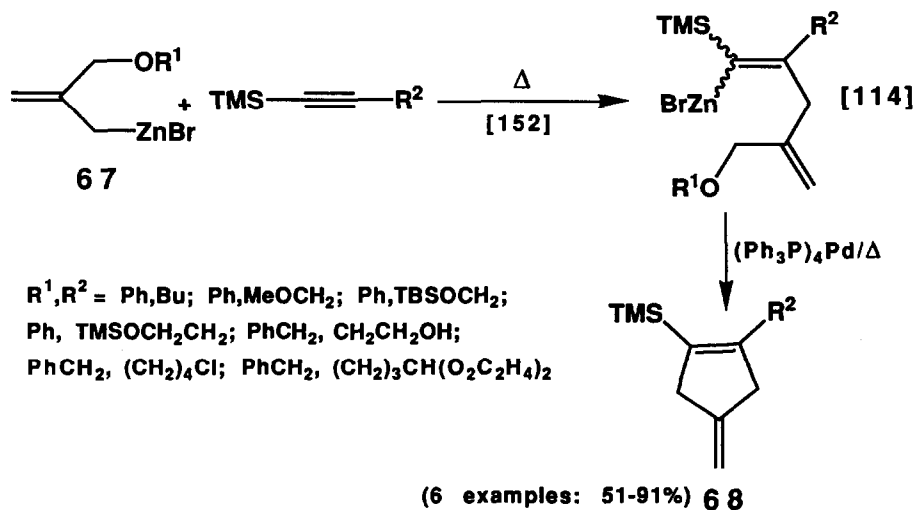

In another cyclization to a vinylsilane the enyne **69** was treated with dicobalt octacarbonyl to give **70** in an approach to carbacyclin precursors. (Eqn. 115) In an intermolecular cyclization the cobalt complex of trimethylsilylacetylene was reacted with (Z) 5-thiomethoxy-2-pentene to give **71** and **72**. (Eqn. 116)

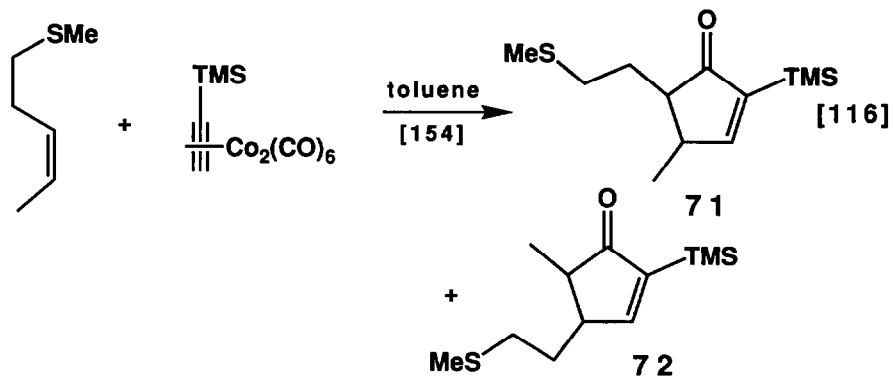
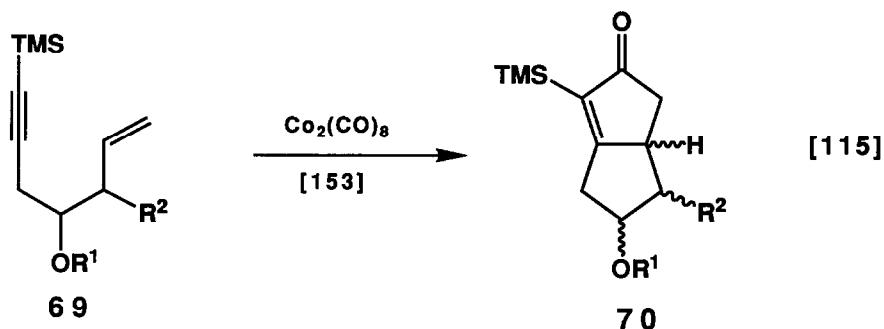

The cyclization of ω -haloethynylsilanes with trimethylaluminum and zirconium(II) or with diisobutylaluminum hydride (DIBAH) gives cyclic vinylsilanes. (Eqn. 117) The reaction is ring-size dependent. (Eqn. 118) The cyclization will also occur with certain vinylsilanes. (Eqn. 119)

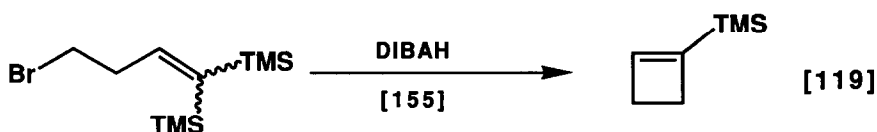
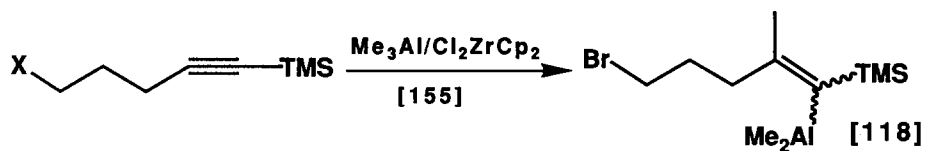
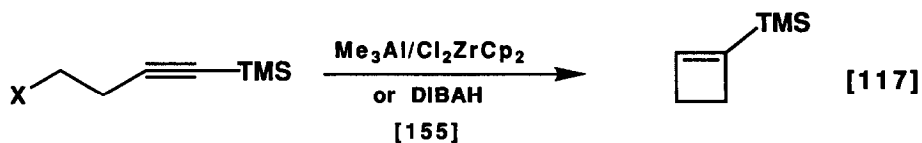

In a related reaction 2-trimethylsilylmethylenecyclopropane was reacted with 1,3-dipolarophiles in the presence of palladium(0) to give *exo*(trimethylsilyl)-methylidenecyclopentanes. (Eqns. 120 and 121) Some allylsilane was also formed in these reactions. Both the vinyl- and allylsilanes could be readily protodesilylated with trifluoroacetic acid. (Eqns. 122 and 123)

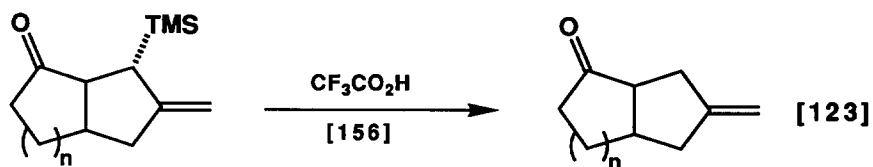
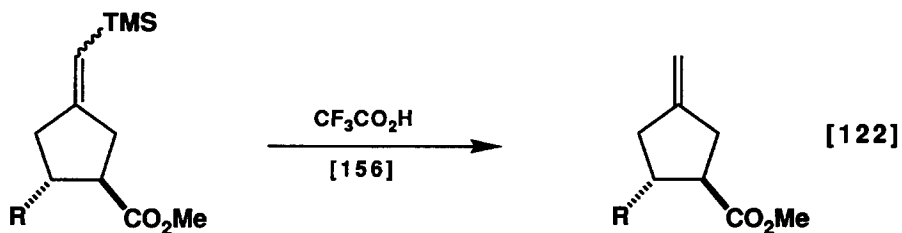
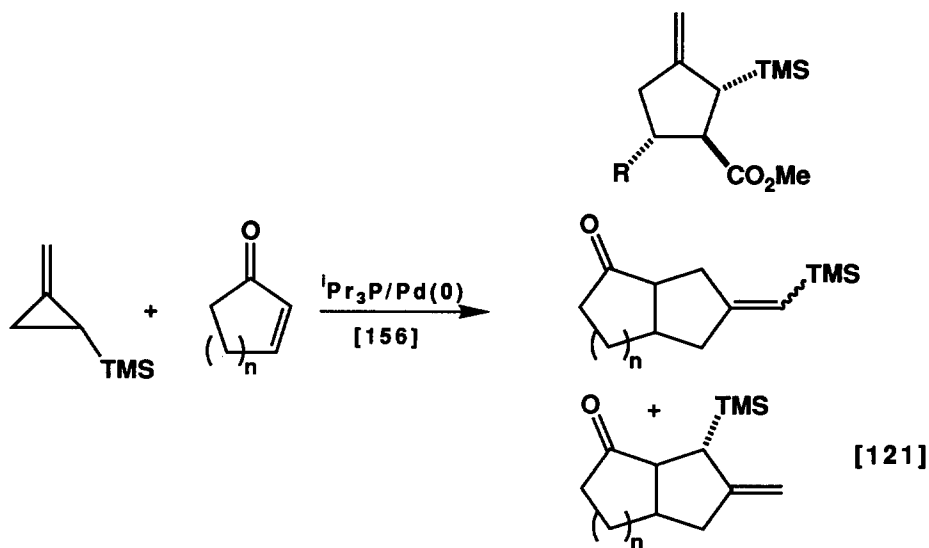
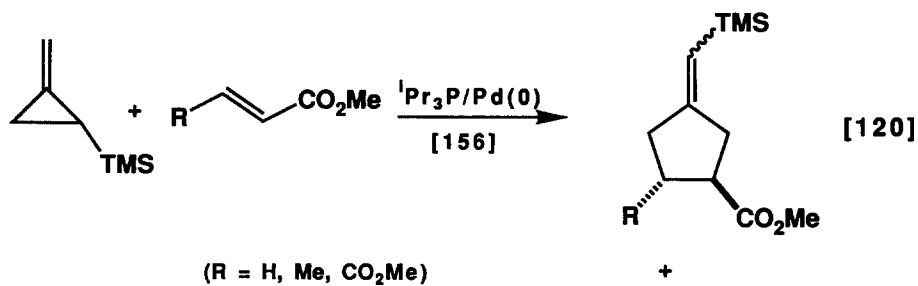

The radical-induced cyclization of two ethynylsilanes was reported. Thus ethynylsilane **73** was treated with tri-*n*-butyltin hydride to give **74**, which could be protodesilylated. (Eqn. 124) Ethynylsilane **75** was treated with hexabutylditin to give **76** and **77**. (Eqn. 125)

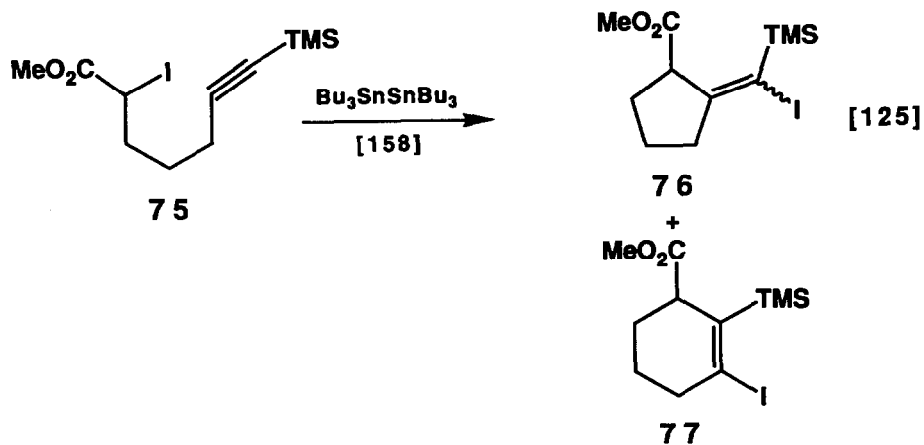
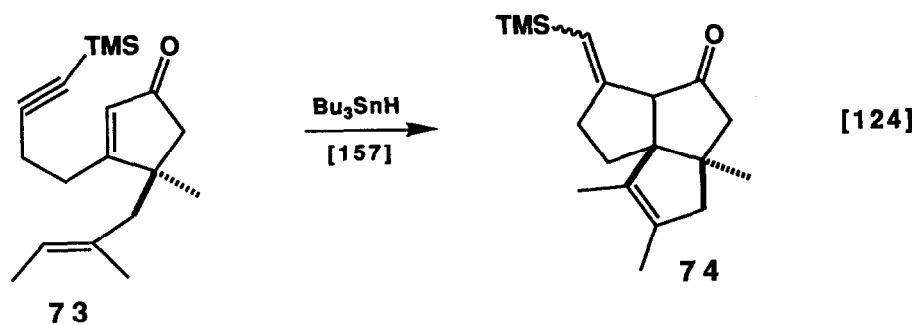

The addition of hydrogen cyanide to ethynyl(*tert*)butyldimethylsilanes gave the vinylsilane. (Eqn. 126) The nitrile group is readily converted to the aldehyde. (Eqn. 127)

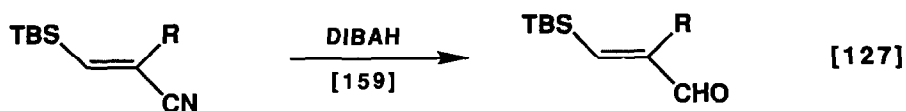
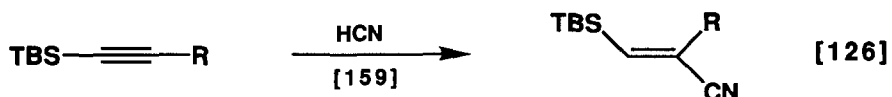

The bis trimethylsilylpropargyl system **78** reacts with electrophiles to give vinylsilanes after migration of a trimethylsilyl group. (Eqn. 128)

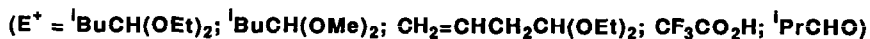
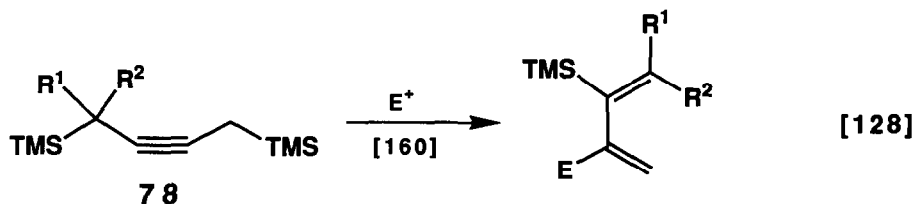

N-Trimethylsilylated imines will add to the electron deficient triple bond of dimethylacetylene dicarboxylate to give a vinylimine, which is at the same time a vinylsilane. (Eqn. 129) The trimethylsilyl group can be removed with cesium fluoride/methanol. (Eqn. 130)

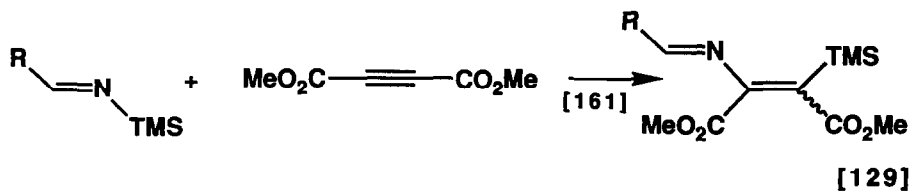

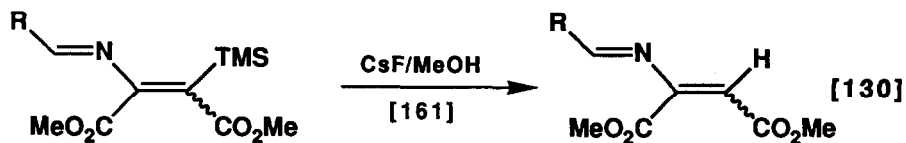

Vinyltrimethylsilane was reacted with 1,3-cyclohexadiene to give **79** in addition to products of addition to vinyltrimethylsilane itself. (Eqn. 131)

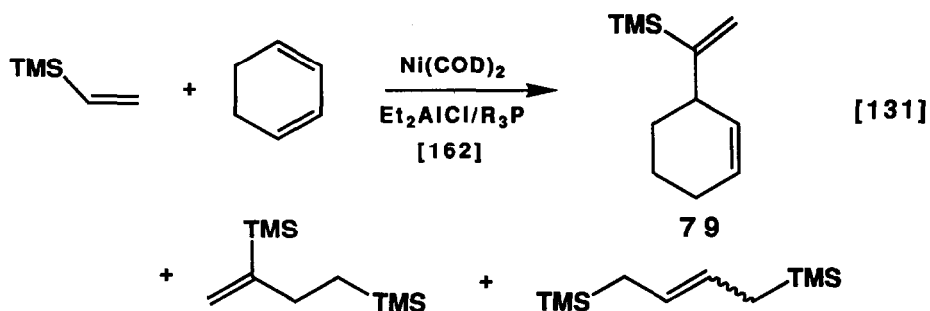

The vinylsilane **80** reacts with cyclopentadiene at the unsubstituted double bond to give **81**. (Eqn. 132)

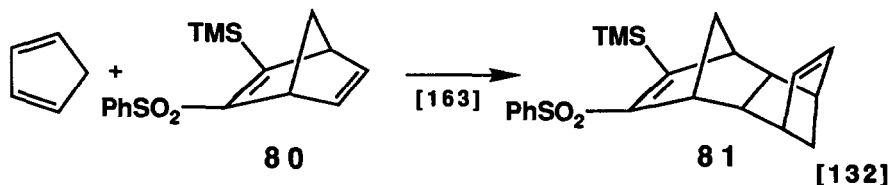

Sym-tetramethyldivinylidisilane reacts with a platinum catalyst to give **82** and **83**. (Eqn. 133)

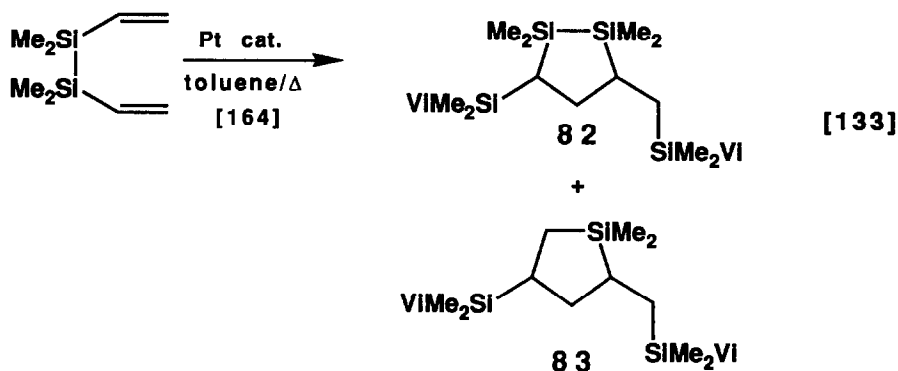

The vinylsilane **84** was reacted with bromine to give the very hindered olefin **85**, which upon treatment with methyllithium gave **86**. (Eqns. 134 and 135)

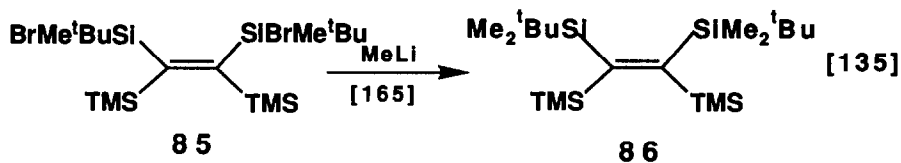
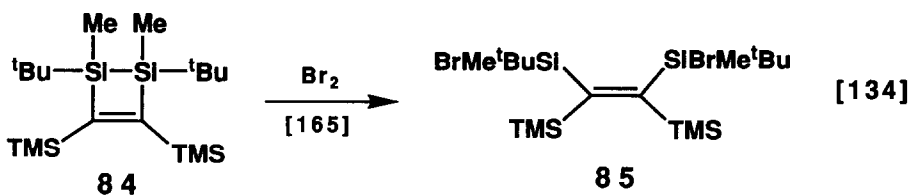

B. Reactions

Addition reactions to vinylsilanes were reported. The addition of HBr to trans-1,2-difluorovinylsilanes gives protodesilylation with retention of configuration of the double bond. (Eqn. 136) Treatment of these same vinylsilanes with sulfuric acid gives fluoromethyl ketones (Eqn. 137) or in the case of the 1,5-diene system **87** the

α -fluorocyclohexanone **88** (Eqn. 138). This ketone synthesis can also be carried out in a manner which allows incorporation of the tert-butyl group as shown in Eqn. 139.

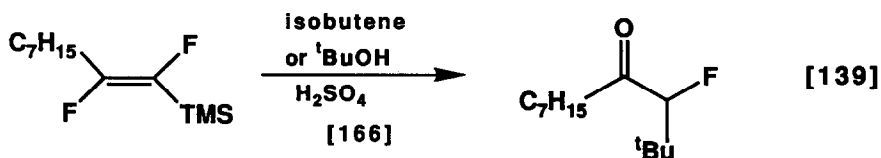
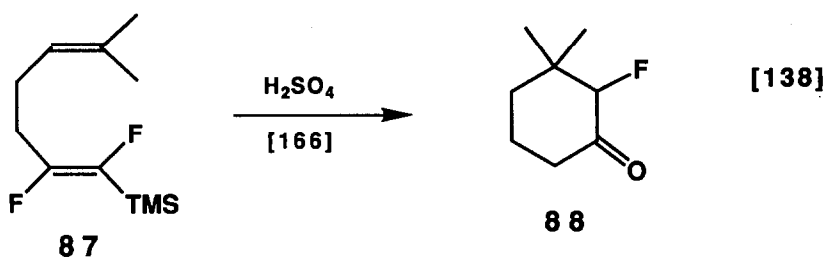
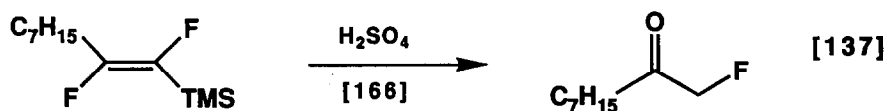
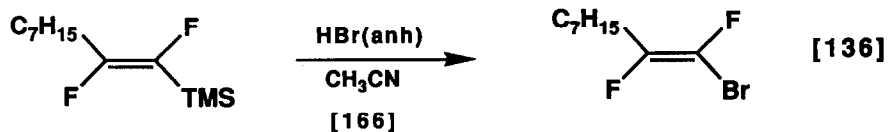

(Z) 1-Bromo-1-alkenylbenzenes were formed by the bromination-elimination of (E) 1-trimethylsilyl styrenes. (Eqn. 140)

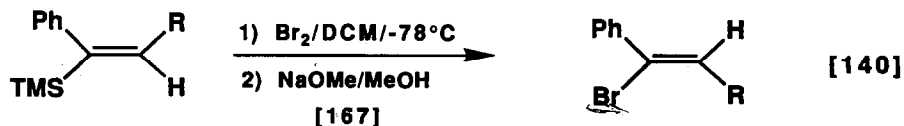

(R = H, Me, Et, Pr)

The addition of 1,1,1-trichloroalkanes to vinyltrimethylsilane in the presence of iron pentacarbonyl was reported. (Eqn. 141) The addition of the S-H bond of mercaptoethylamine hydrochloride to vinylsilanes was reported. (Eqn. 142)

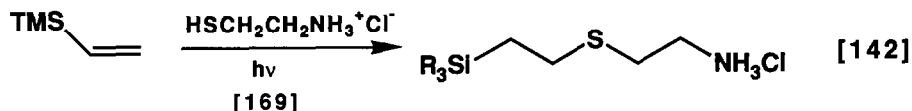
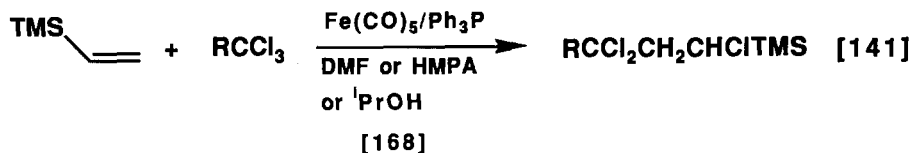

The addition of activated halides to the vinyl group of vinylsilatrane in a radical manner was accomplished. (Eqn. 143)

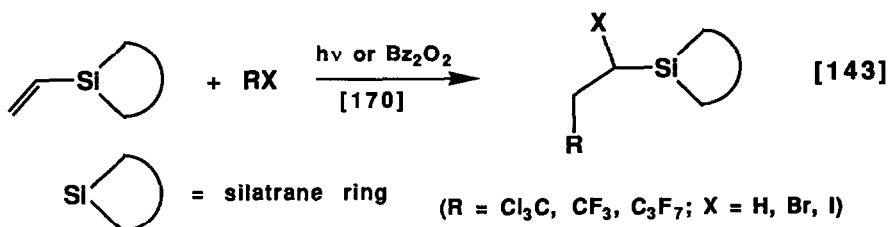

The reaction of (trimethylsilyl)ketene diethyl acetal with N-(chloromethyl)-lactams leads to esters of the type **89** when the reaction is carried out with a 1:1 ratio of reagents (Eqn. 144), and type **90** when two equivalents of the vinylsilane are used (Eqn. 145).

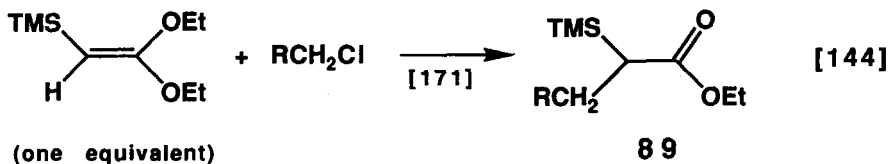

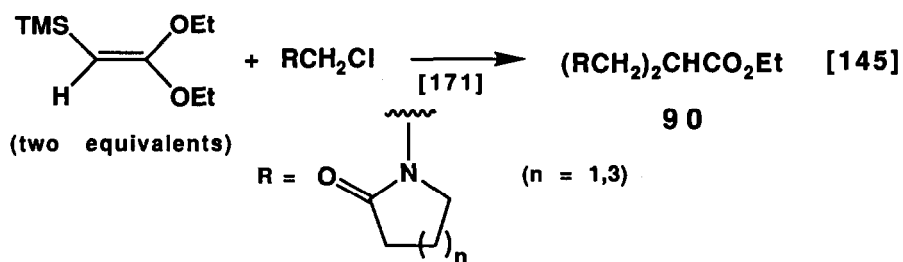

The hydrogenation of tetrakis(trimethylsilyl)-1,2,3-butatriene gives reaction at one of the terminal double bonds. (Eqn. 146) The same is true for the hydrosilation with trimethylsilane (Eqn. 147), oxidation with MCPBA (Eqn. 148), but not with oxidation with perbenzoic acid, which results in the loss of a trimethylsilyl group (Eqn. 149).

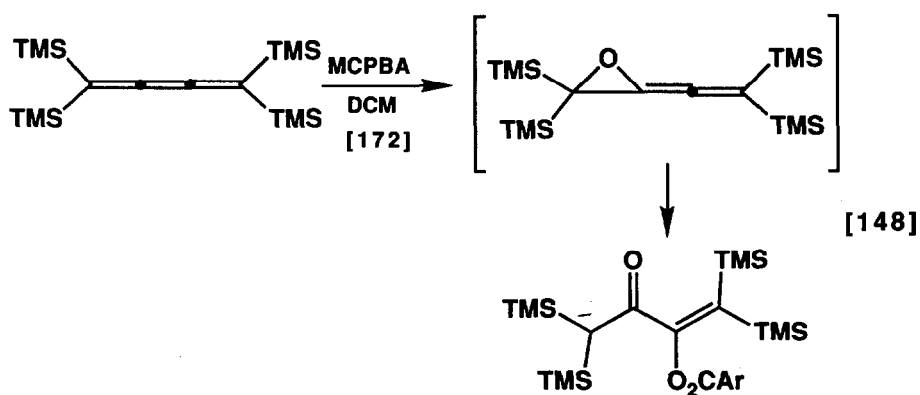
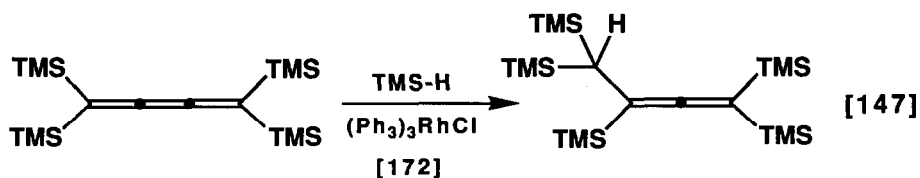
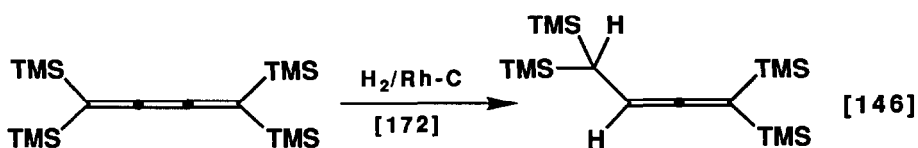

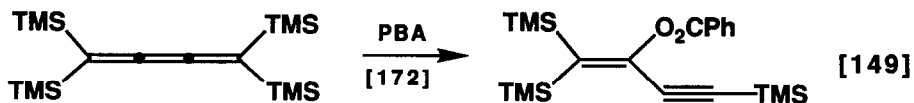

The palladium catalyzed hydrogenation of 2-(dimethylsilyl)dihydropyran gives initially the expected tetrahydropyran, which then rearranges to **91**. (Eqn. 150)

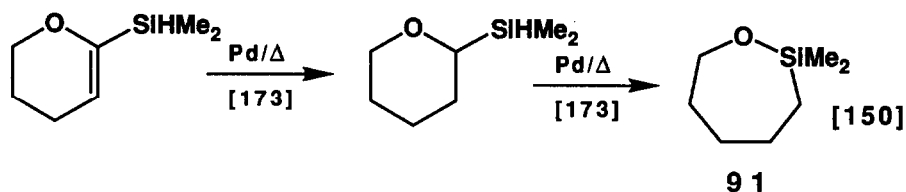

The addition of thiols to the trimethylsilylated aldimine **92** was reported. (Eqn. 151)

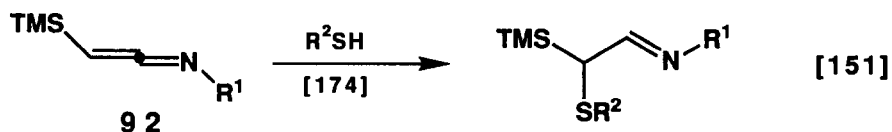

It was shown that the addition of tert-butyllithium to vinylsilanes at dilute conditions results in the addition of the tert-butyllithium followed by elimination of lithium hydride as the principle reaction pathway. (Eqn. 152) At higher concentrations the reaction pathway is that of addition-condensation. (Eqn. 153)

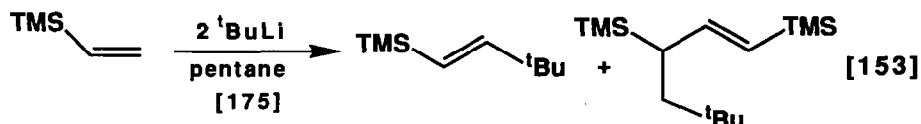
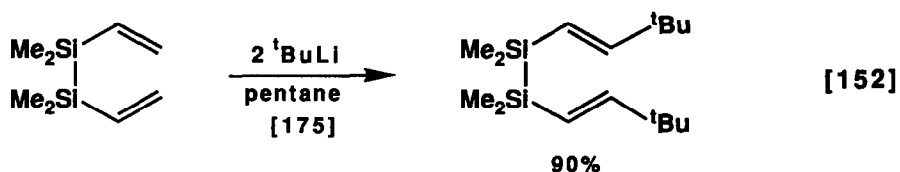

Deprotonation of either allyltriphenylsilane or *trans*-1-triphenylsilylpropene gives the expected anion (lithium reagent) which undergoes electrophilic attack. (Eqn. 154)

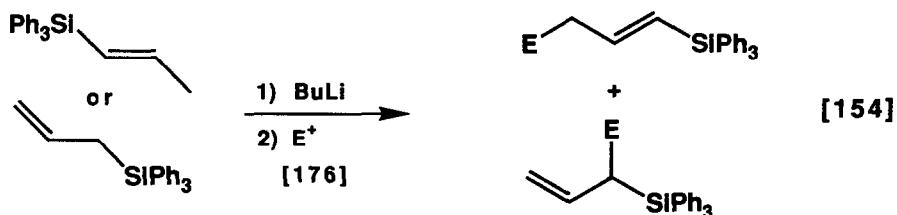

The optically active vinylsilane **93** was subjected to metal-halogen exchange with *tert*-butyllithium and the resulting vinyl lithium reagent reacted with aldehydes in the presence of boron trifluoride etherate to give an equimolar mixture of diastereomeric alcohols **94**, some of which could be separated. (Eqn. 155) Protodesilylation of the separated diastereomers then provided optically active allyl alcohols. (Eqn. 156) Conversion of one of these systems **95** to the trifluoroacetate and then elimination lead to the optically active allene **96**. (Eqn. 157)

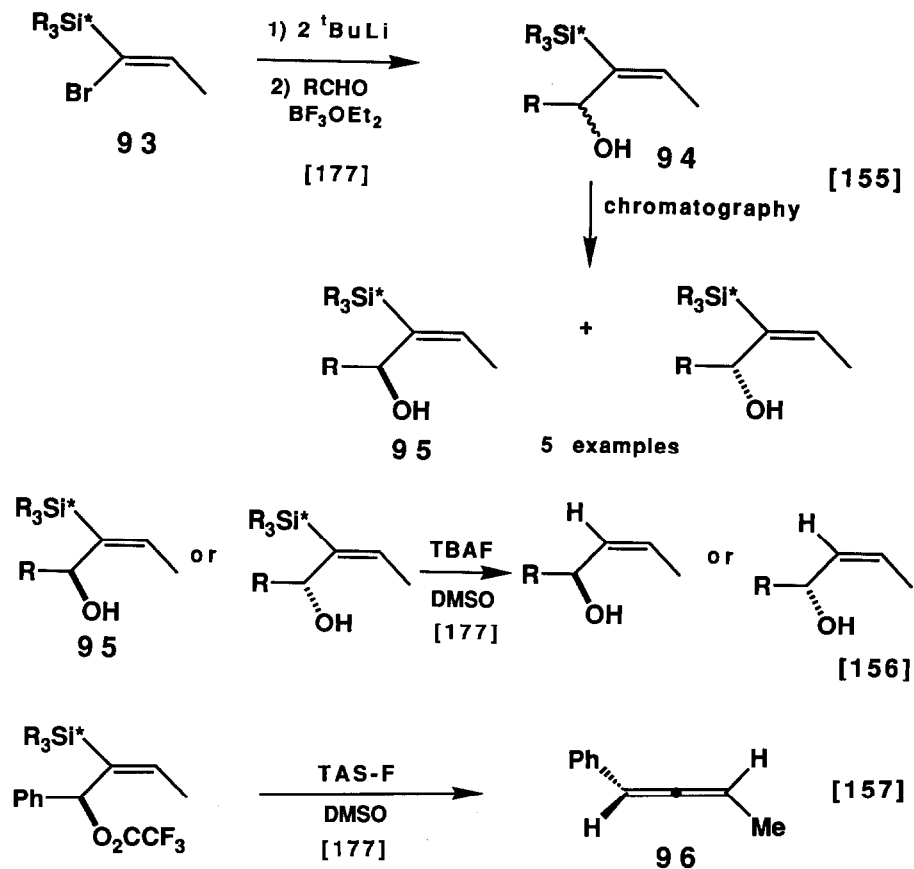

The 2,3-Wittig rearrangement of **97**, formed in a straightforward manner was used to produce β -hydroxysilanes **98**. (Eqn. 158) These were used to prepare (E,Z) and (Z,Z) 1,3-butadienes. (Eqns. 159 and 160)

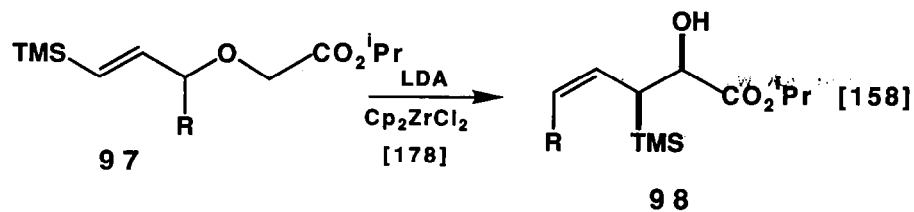

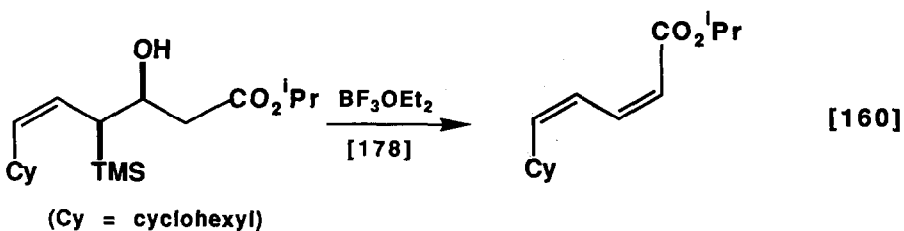
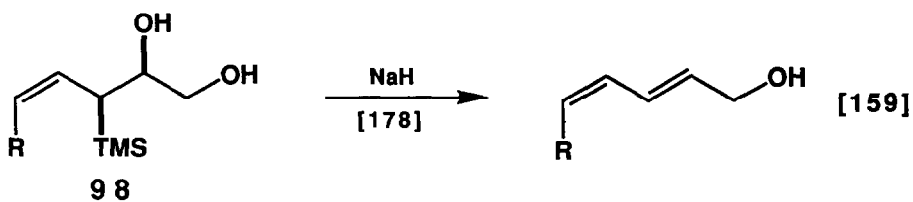

Vinyltrimethylsilane was reacted with vinyl iodides and vinyl triflates under the influence of palladium(II) acetate to give 1-trimethylsilyl-1,3-butadienes. (Eqns. 161 and 162) This same coupling will occur with vinyl bromides (Eqn. 163) and vinyl boronic acids (Eqn. 164) as well.

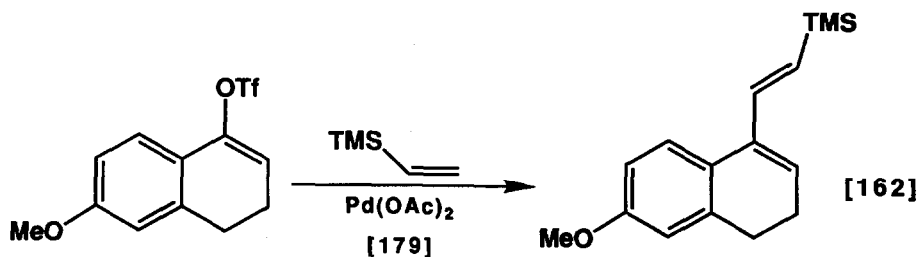
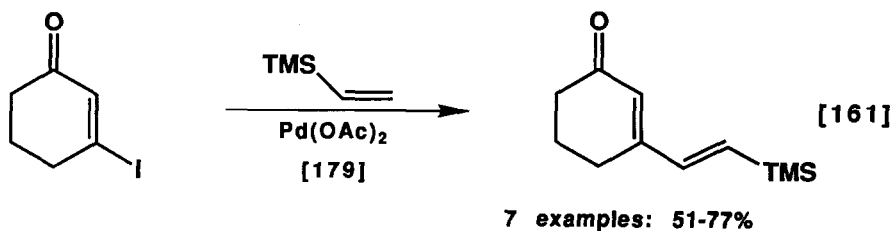

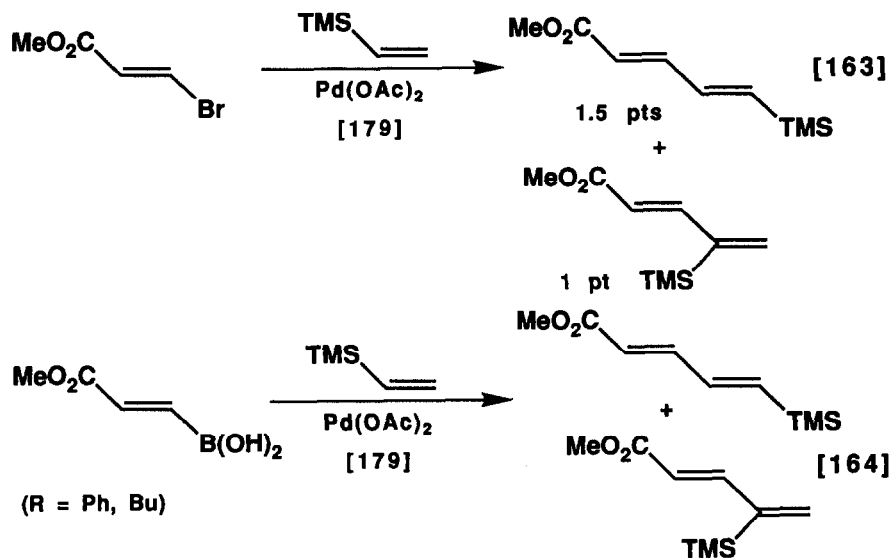

The coupling of vinyltrimethylsilane with aryl and vinyl iodides in the presence of tris(diethylamino)sulfonium difluorotrimethylsilicate (TAS-F) and palladium(II) was reported. (Eqns. 165 and 166)

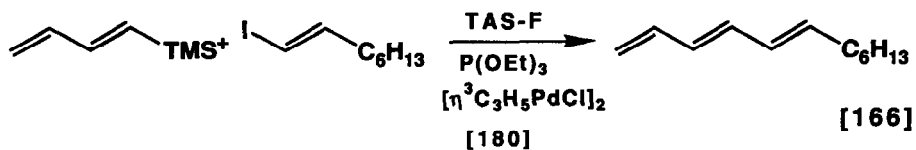
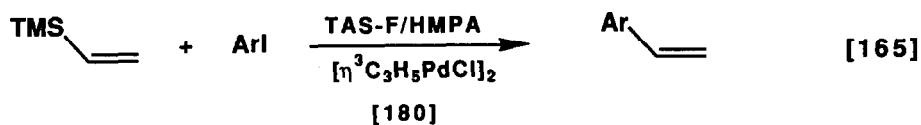

Trimethylsilyl ketene was reacted with furan diones to give pyrones. (Eqn. 167)

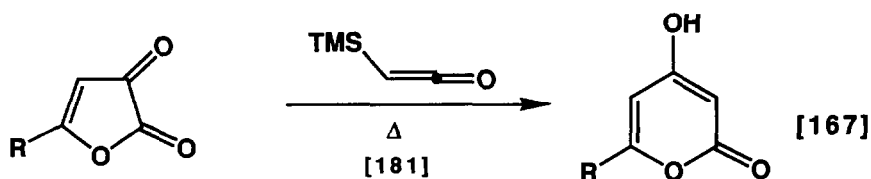

Vinylsilanes were involved in several reported cyclization reactions. The bis(trimethylsilyl) butadiene **99**, prepared by bromination of trimethylsilyl acetylene and then treatment of the dibromide with tert-butyllithium in the presence of cuprous iodide, was cycloadditioned to maleic anhydride (Eqn. 168) and other dienophiles as well. In a related system **100** was reacted with maleic anhydride. (Eqn. 169)

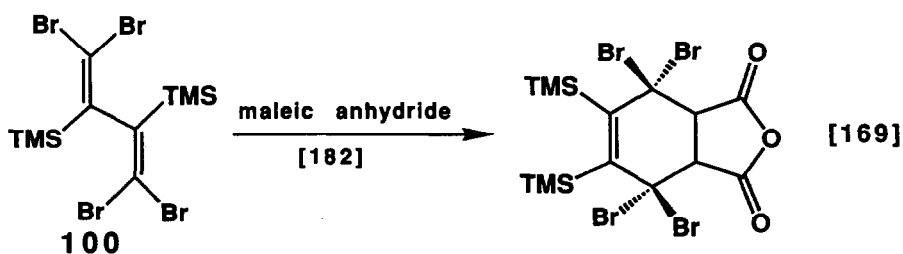
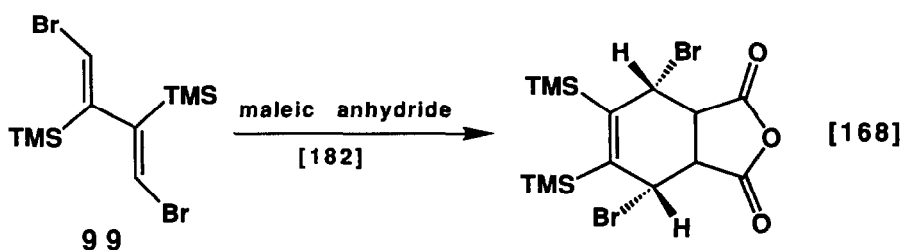

1-Trimethylsilylacetylene carboxylic acid was reacted with dienes (Eqn. 170) as were (Z) 2-trimethylsilyl acrylic acid (Eqn. 171) and (E) 2-trimethylsilyl acryloyl chloride (Eqn. 172).

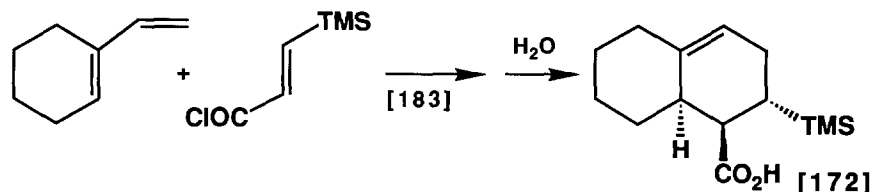
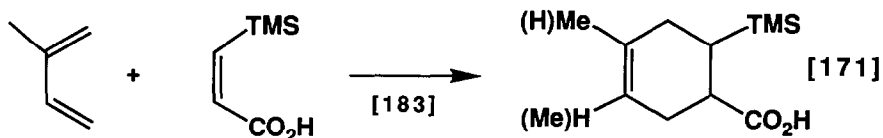
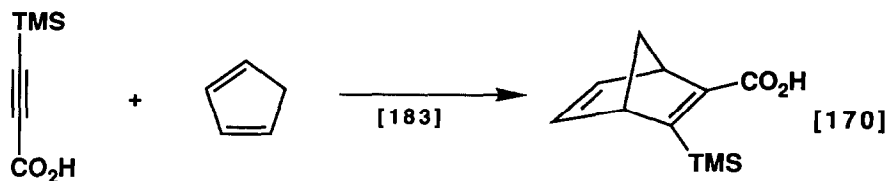

3-Trimethylsilyl-3-sulfolene was the source of 2-trimethylsilyl-1,3-butadienes for cycloadditions. (Eqn. 173) This system has the advantage that various groups can be introduced into the diene *via* alkylation procedures.

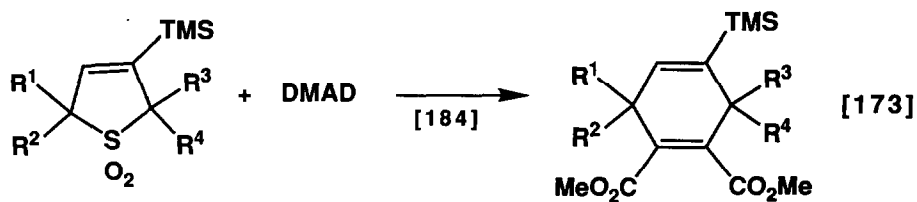

Cycloadditions were also reported with 1-trimethylsilyl-3-oxy-1,3-butadienes. Thus 1-trimethylsilyl-3-trimethylsilyloxy-1,3-butadiene was added to acryloyl chloride (Eqn. 174) and to ethynyl nitrile (Eqn. 175). Similarly, 1-trimethylsilyl-3-acetoxy-1,3-butadiene was reacted with **101**. (Eqn. 176)

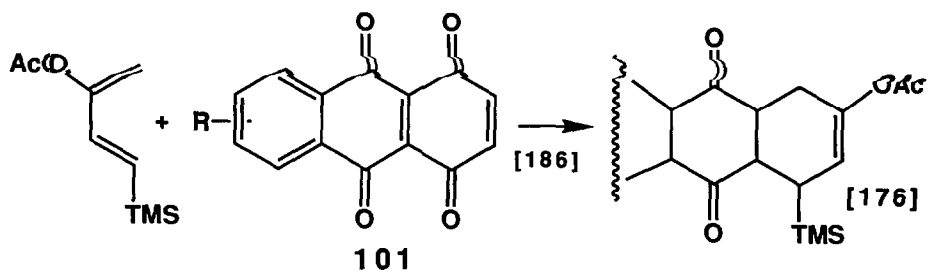
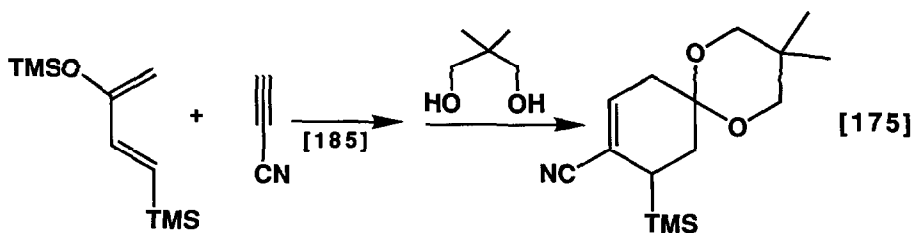
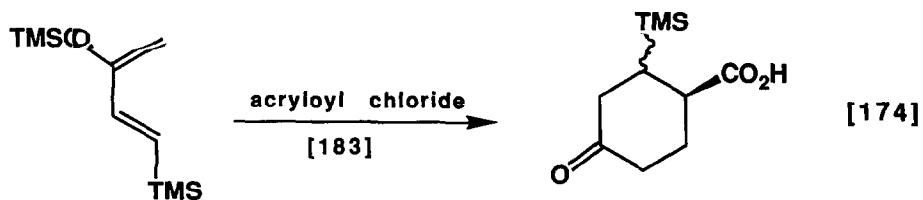

The vinylsilane group was used to direct the Nazarov cyclization as has been shown in earlier work. The mechanistic details of this useful reaction have now been reported (Eqn. 177) and the scope and limitations in terms of the presence of various groups has been determined (Eqn. 178).

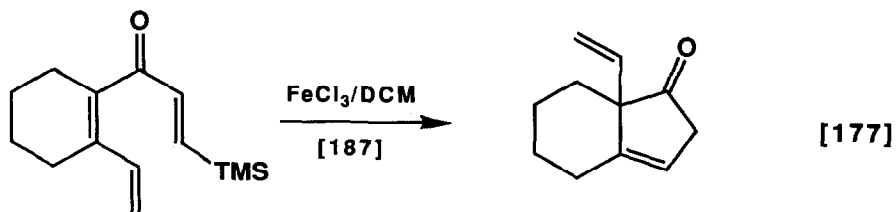

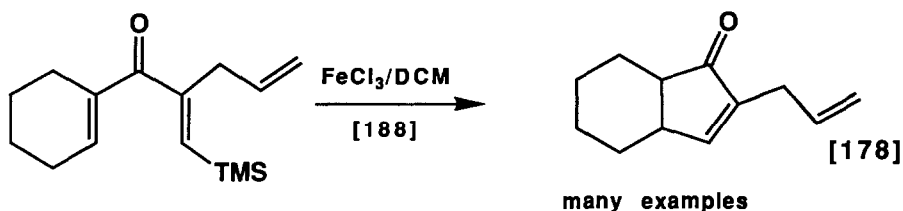

The vinylsilane **102** was reacted with aldehydes in the presence of a catalytic amount of fluoride ion to give the expected condensation product. (Eqn. 179)

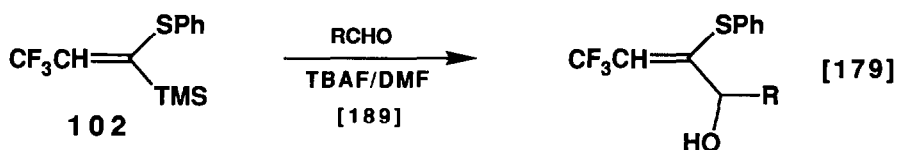

The 1-silacyclopentadiene **103** reacts with sodium/potassium alloy to give red-brown, air sensitive solid, which when reacted with methyl iodide gives **104** or with trimethylchlorosilane to give **105**. (Eqns. 180 and 181)

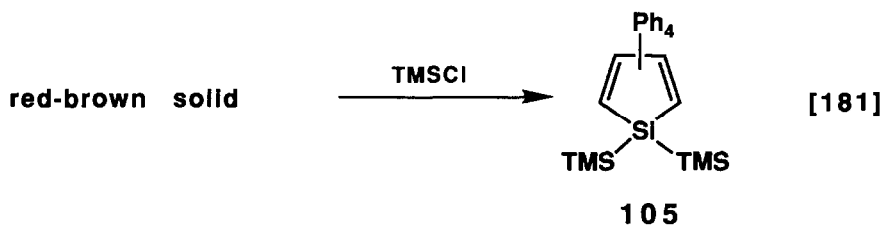
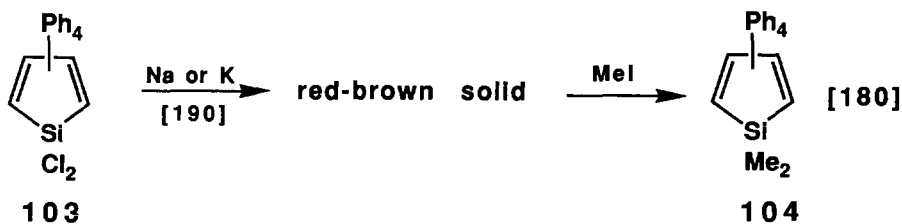

Pyrolysis of **106** gives **107** in a rearrangement process. (Eqn 182)

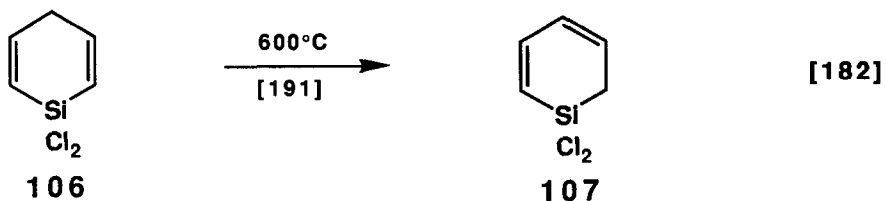

C. Other Studies

The ring puckering potential energy of **108** was studied. The data confirm that the system is planar. [192] The ^{29}Si NMR spectra for several vinyl and acetylenic silanes were reported. [193] The π donor ability of various vinyl systems including vinylsilanes was studied. [194] The silacycle **109** is the first reported sila-substituted vitamin. [195]

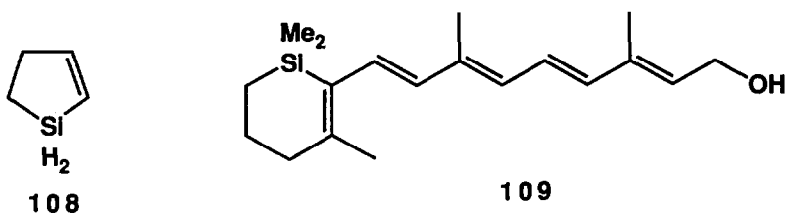

VIII. ETHYNYLSILANES

A. Preparation

The interesting ethynylsilane **111** was prepared in a straightforward manner

from **110**. (Eqn. 183) This product was oxidized to the amine oxide **112** (Eqn. 184) or the allenyl hydroxyl amine **113** (Eqn. 185).

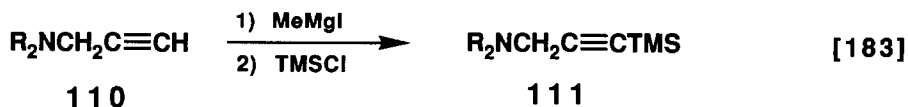

(several examples of R groups on the amine used)

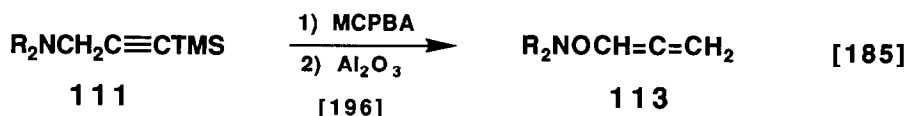
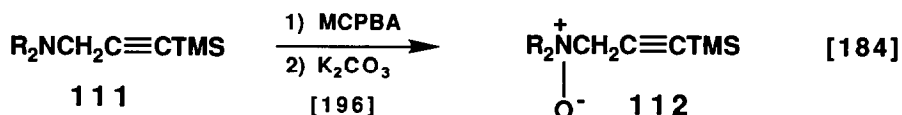

Cyclopropylethynyltrimethylsilane was prepared. (Eqn. 186) Deprotonation-trimethylsilylation of this material gave the propargylsilane. (Eqn. 187)

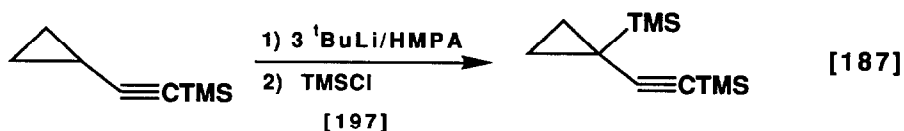
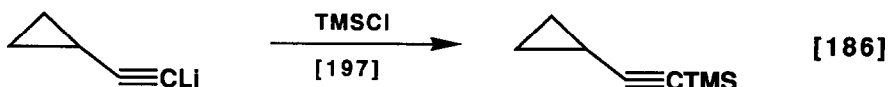

Tri(tert)butyltin substituted acetylenes were silylated (Eqn. 188) and then later converted to the iodo derivatives (Eqn. 189).

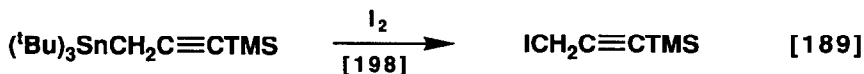

Trimethylsilylacetylene and similar materials were shown to react with aryl halides in the presence of palladium(II) to give aryl trimethylsilylacetylenes.

Representative examples from three reports are given. (Eqns. 190-192)

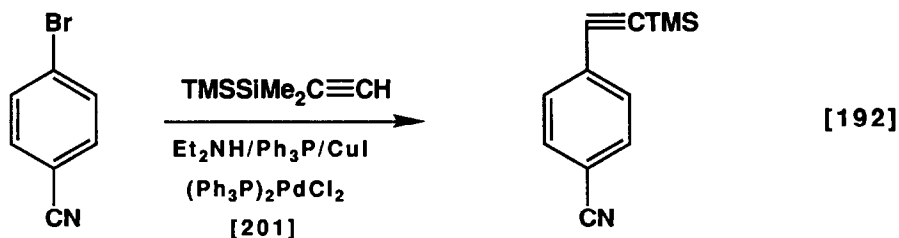
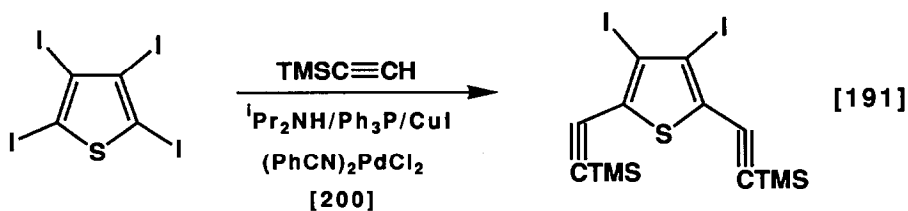
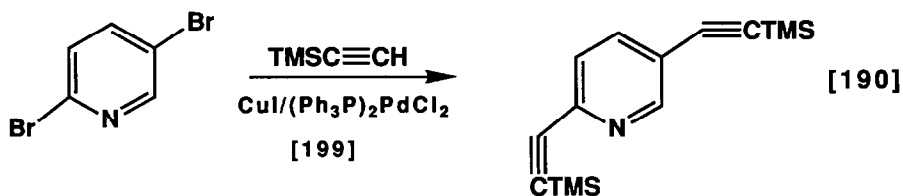

The di-magnesium salt of diethynyldimethylsilane was reacted with 1,2-bis(dimethylfluorosilyl)ethane to give **114**. (Eqn. 193)

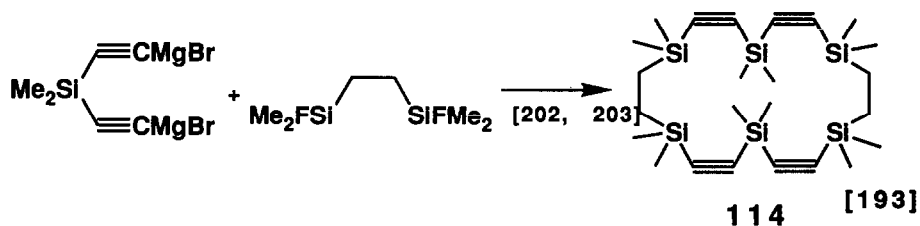

3-Bromo-1-trimethylsilylpropyne was reacted with triphenylarsine to form the arsonium salt **115** (Eqn. 195), which was then used in a Wittig type reaction (Eqn. 196).

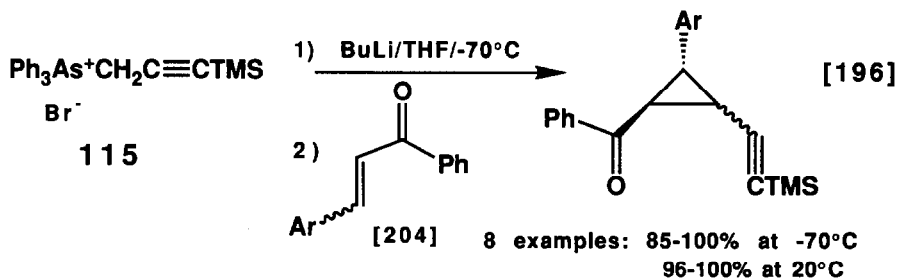

B. Reactions

Electrophilic substitution of ethynylsilanes continued to be reported.

Ethynylsilane **116** was acylated in excellent yields with acid chlorides or anhydrides in the presence of aluminum chloride. (Eqn. 197) Intramolecular activation of acid anhydrides allows reaction with ethynylsilanes. (Eqn. 198)

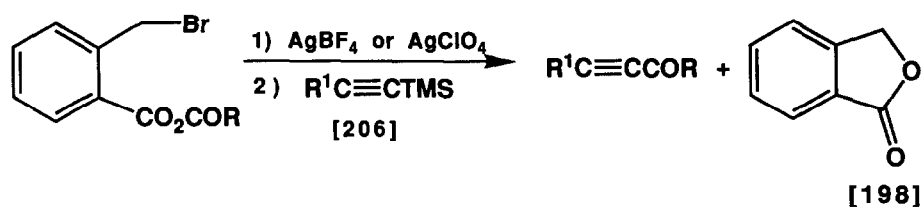
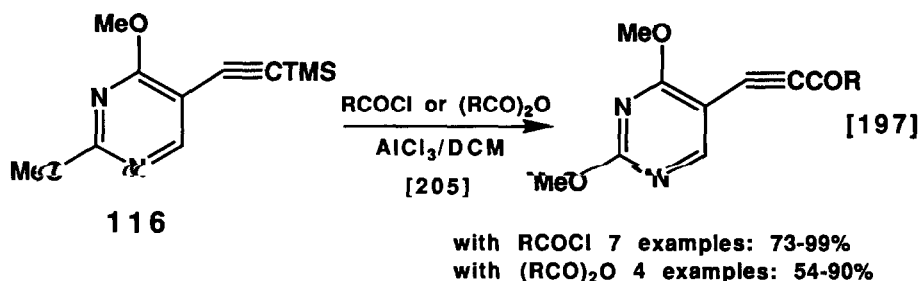

The reaction of acetals with ethynylsilanes to give substituted propargyl alcohols was reported. (Eqn. 199) The reaction also occurs with aldehydes. (Eqn. 200)

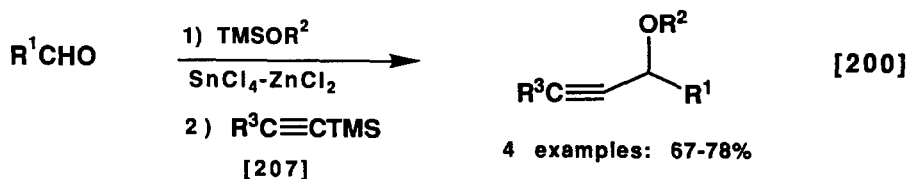
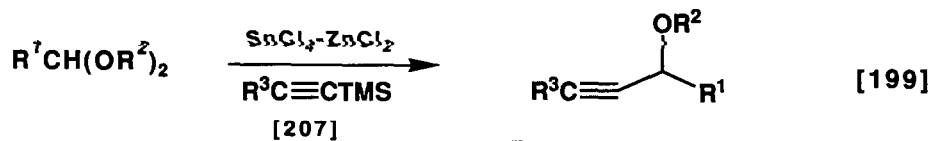

The reaction of ethynylsilanes with phenyliodonium oxide and then sodium arylsulfonates gives ethynylphenyl iodonium sulfonates. (Eqn. 201)

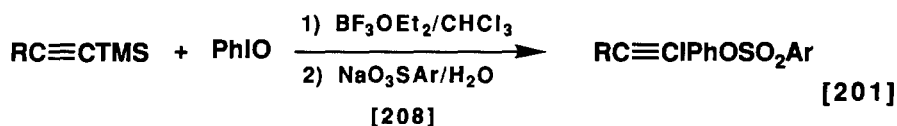

The addition of secondary amines to (trimethylsilyl)propynal was reported to give β -amino acroleins. (Eqn. 202)

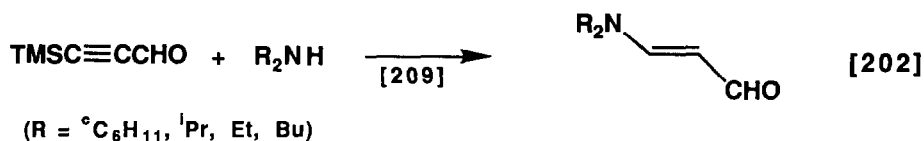

The photocycloaddition of tetramethylethylene to the triyne **117** was reported to give the cyclopropyl diynes **118** and **119**. (Eqn. 203)

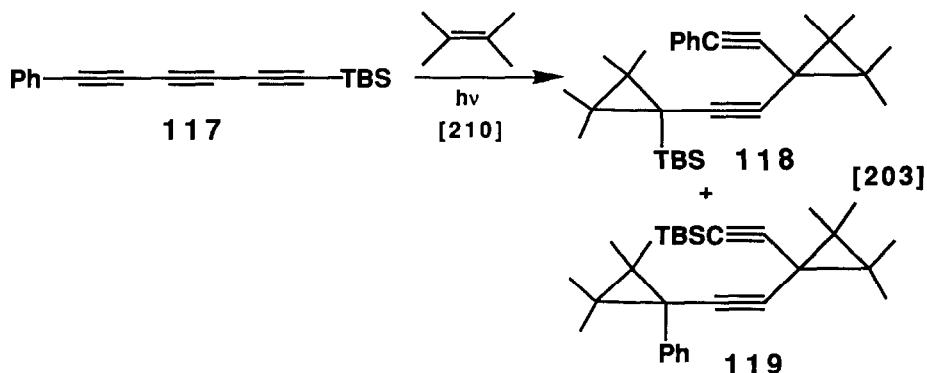

The hydroformylation of trimethylsilylacetylene was shown to proceed in good yield. (Eqn. 204)

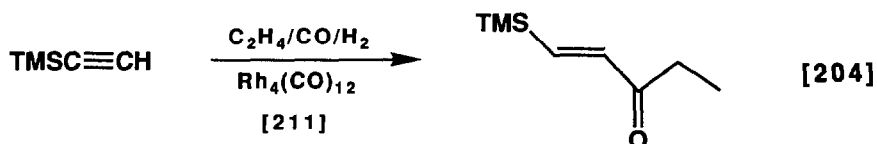

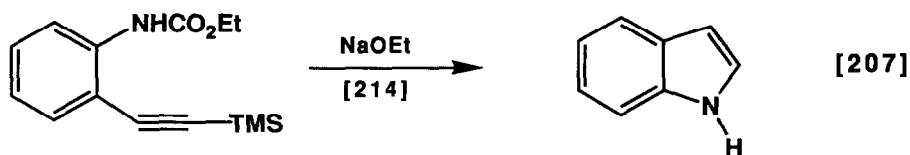

The cycloaddition of bis(trimethylsilyl)acetylene with **122** gives 3-cyano-indolizines. (Eqn. 208)

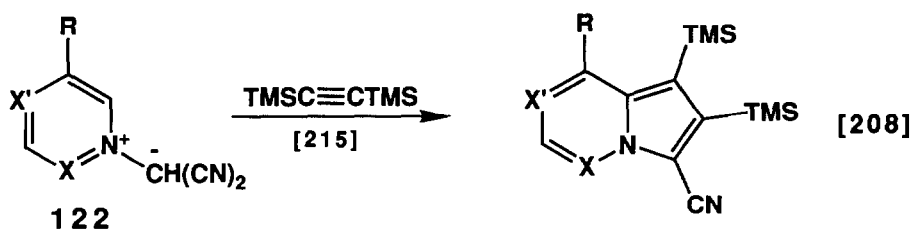

The intramolecular radical cyclizations of various vinyl bromides containing the ethynylsilyl group were investigated. The cyclization was ring size dependent. (Eqns. 209-211)

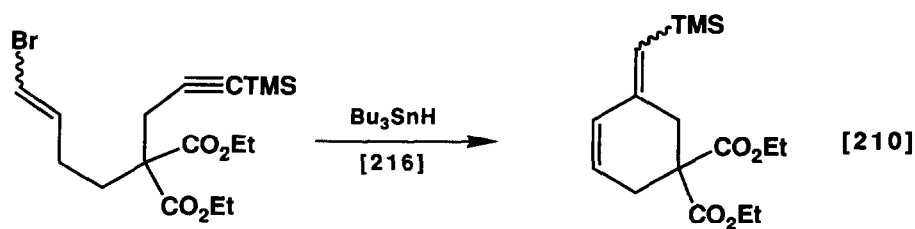
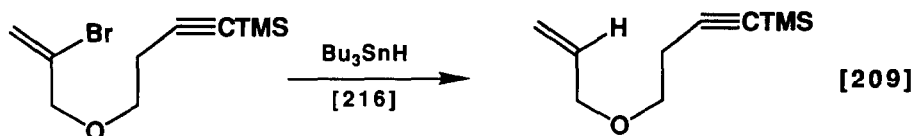

21% yield + 41% reduction

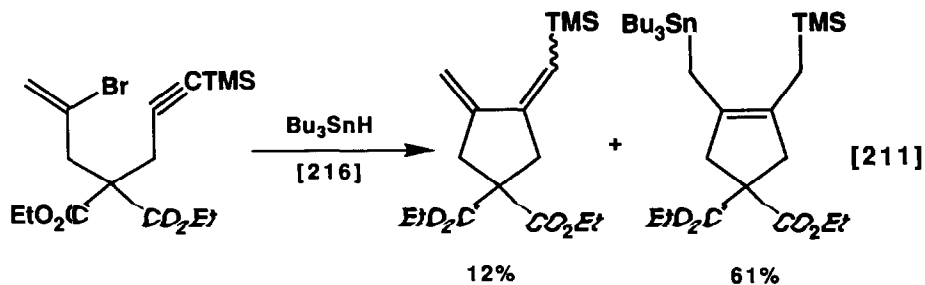

The mercury(II) mediated cyclization of ethynylsilane units with trimethylsilyl enol ethers was reported. (Eqn. 212)

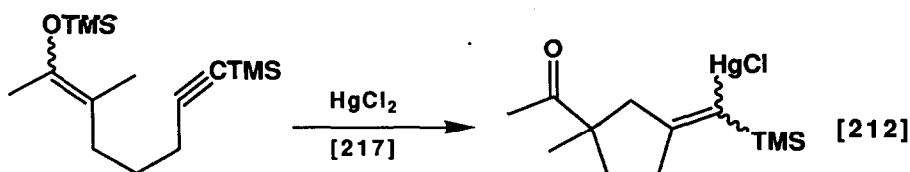

Bicyclic keto silanes were prepared by the intramolecular cyclization of ethynylsilanes with ketones under thermal conditions. (Eqn. 213) The reaction occurs through the enol form of the ketone and involves a migration of the trimethylsilyl group.

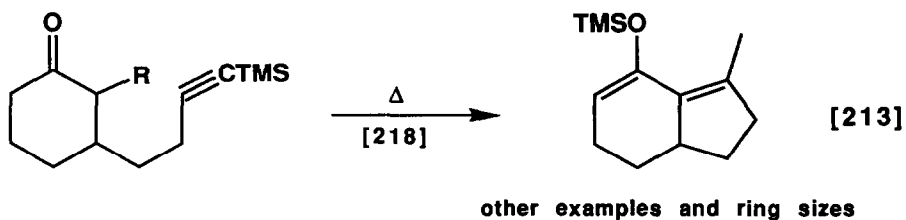

The intramolecular cyclization of an ethynylsilyl group with a chromium carbene complex was used to obtain fused furans. (Eqn. 214)

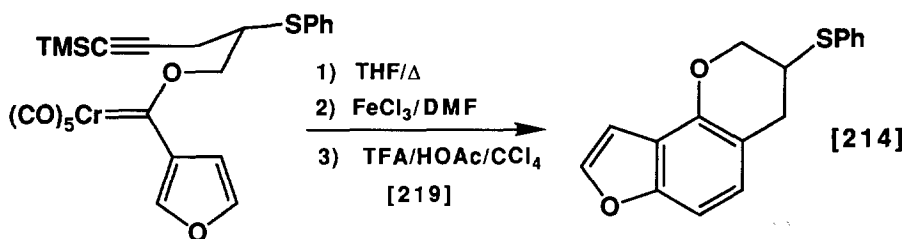

1-Trimethylsilylpropargyl alcohols were converted to the lithium carbonates, which were cyclized and allylated. (Eqn. 215)

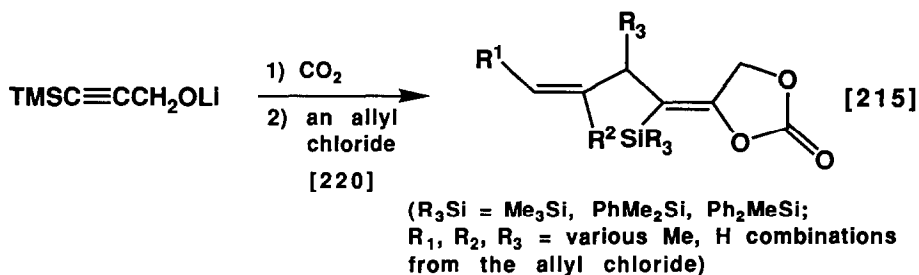

C. Other Studies

The combination of trimethylsilylethynylcopper and trimethylchlorosilane was shown to greatly enhance the conjugate addition of organocopper reagents to unsaturated esters. [221] The polarizability studies on bis(trimethylsilyl)acetylene do not indicate any long-lived bent conformers of this acetylene. [222] The basicity and conjugation effects of several methoxysilyl(trimethylsilyl)acetylenes was studied. [223]

IX. ALLYLSILANES

A. Preparation

The reaction of dihydrofurans with trimethylsilylmethylmagnesium chloride in the presence of nickel(II) leads to ring opening and allylsilanes. (Eqn. 216)

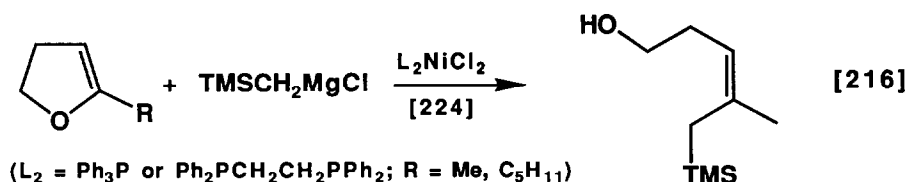

Tris(trimethylsilylmethyl)borane was reacted with ethynyllithium reagents to form the borate complex, which was then reacted with electrophiles to provide allylsilanes **123**. (Eqn. 217) These materials could be protodeboronated to electrophilically substituted allylsilanes (Eqn. 218) or treated with alkaline iodine solution to give the bis(trimethylsilyl)allylsilanes **124** (Eqn. 219). A similar approach, but with the trimethylsilylmethyl group being added as the electrophile in the form of trimethylsilylmethyl trifluoromethanesulfonate, gives either allylsilanes or β -trimethylsilyl ketones. (Eqns. 220-222)

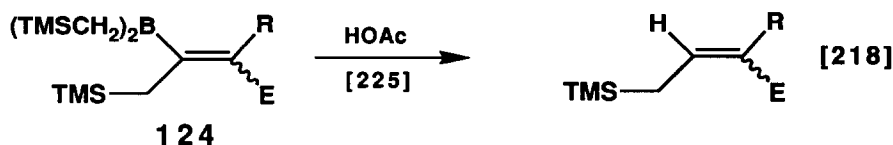
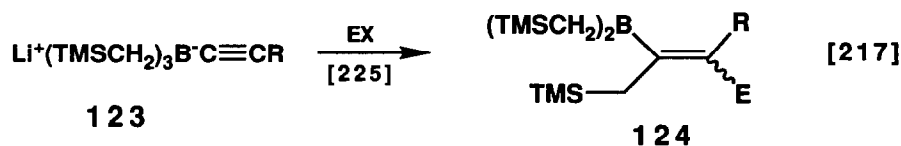

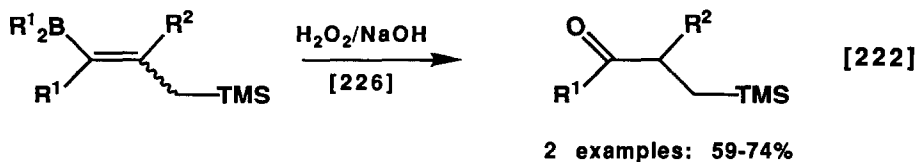
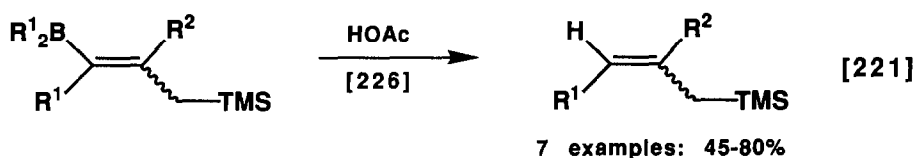
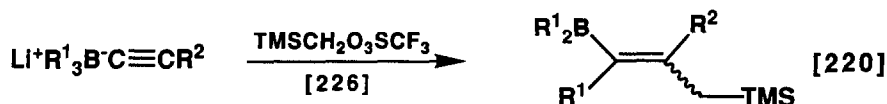
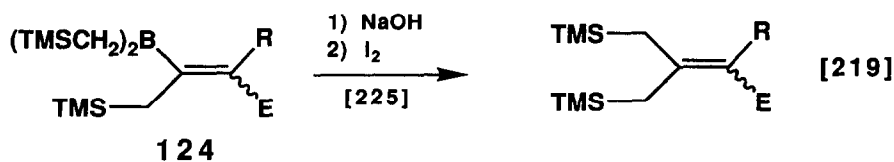

The reaction of propargylsilanes with tributyltin hydride provides allylsilanes, which are also vinylstannanes. (Eqn. 223) In one such system it was shown that elimination of tributylstannol to give trimethylsilylmethylallenes is possible. (Eqn. 224) On the other hand, conversion of the alcohol in these systems to the acetate followed by treatment with trifluoroacetic acid leads to 2-(tributylstannyl)-1,3-butadienes. (Eqn. 225)

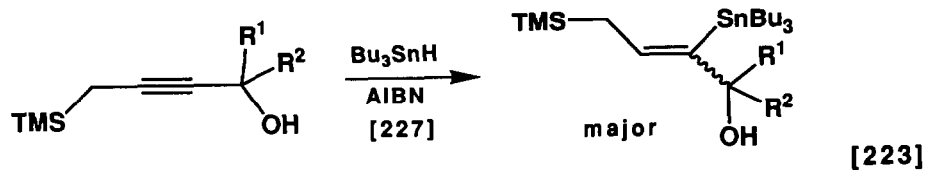

15 examples: 61-86%

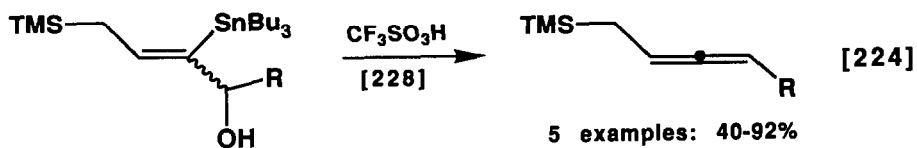

5 examples: 40-92%

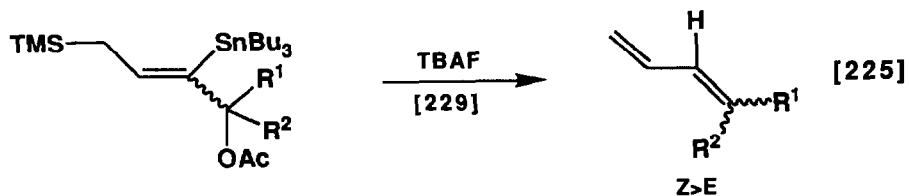

π -Allyl palladium complexes were shown to react with disilanes to give allylsilanes. (Eqns. 226 and 227)

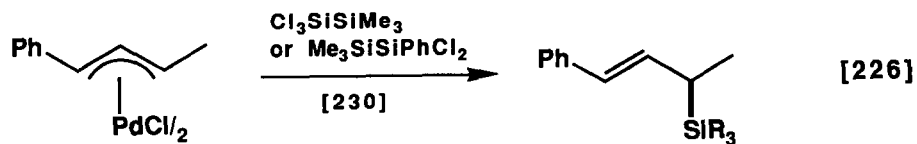

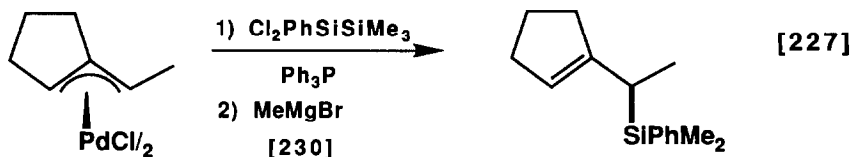

Disilanes were also reacted with α,β -unsaturated ketones in the presence of palladium(0) to give allylsilanes, which are also enol silyl ethers. (Eqn. 228) These can be electrophilically alkylated through the enol silyl ether to ketones (Eqn. 229) and the silicon-carbon bond oxidized by virtue of the Leaving groups on silicon to β -hydroxy ketones (Eqn. 230). In the presence of a palladium(II) chloride complexed with an optically active bidentate ligand optically active β -hydroxy ketones are possible.

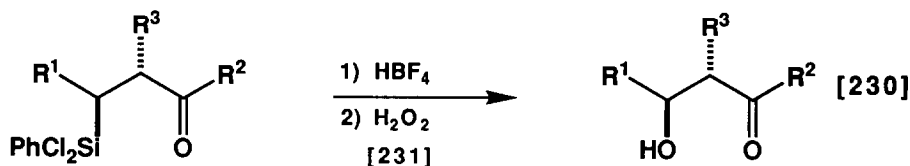
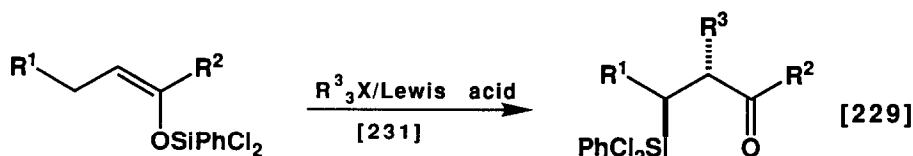
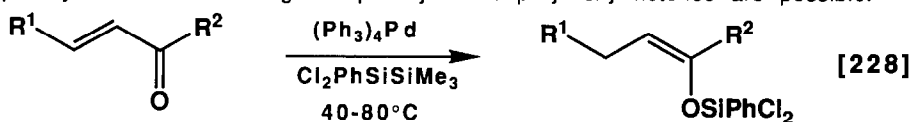

It has been shown that allyl alcohols can be reacted with disilanes *via* their lithium salts. The trimethylsilyl anion resulting from the attack of the lithium alkoxide on the disilane then can react with the silyl ether to give allylsilanes. (Eqn. 231) Due to this type of dual behavior of disilanes they have been termed "counter-attack reagents".

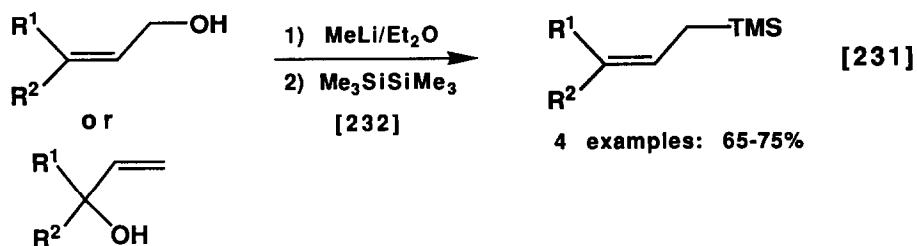

Various kinds of silylmetal reagents were employed in the synthesis of allylsilanes. [Tris(silyl)manganese]methylmagnesium was reacted with allylsulfides to give allylsilanes. (Eqn. 232)

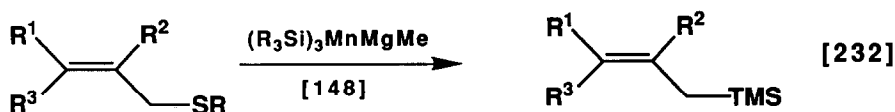

(Phenyldimethylsilyl)diethylaluminum was reacted with activated vinylcyclopropanes to give allylsilanes. (Eqn. 233) Other silylmetal systems were also investigated in this reaction.

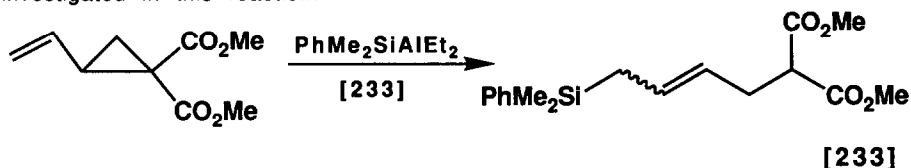

Lithium bis(phenyldimethylsilyl)cuprate was reacted with lactone **125** to give the allylsilane **126**. (Eqn. 234) This allylsilane was used in the preparation of **127**, which was cyclized to **128** (Eqn. 235), which in turn was converted to racemic epiwiddrol.

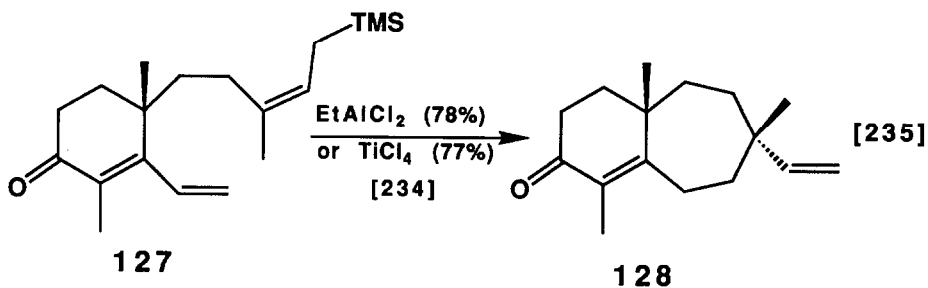
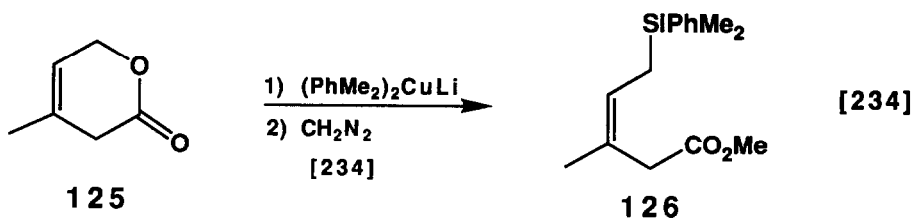

Trimethylsilylcopper(I) dimethylsulfide was reacted with allyl chloride **129**, which was used to allylate **130**. (Eqns. 236 and 237) The product of this allylation was converted to racemic tricyclohexaprenol.

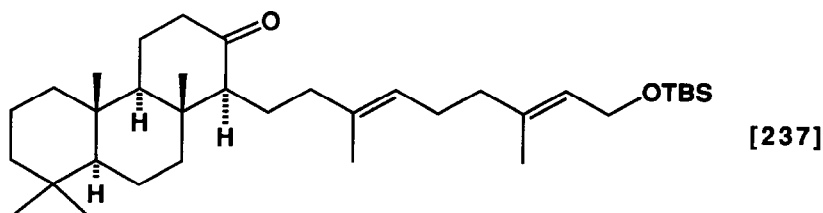
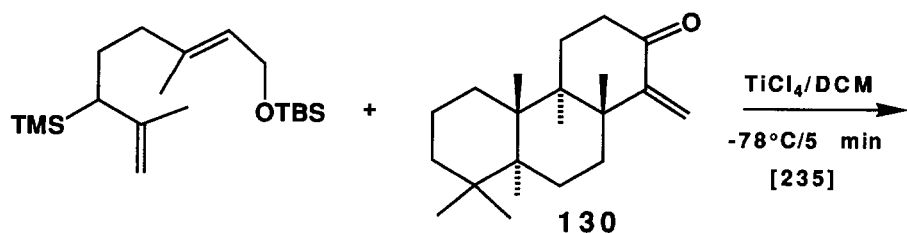
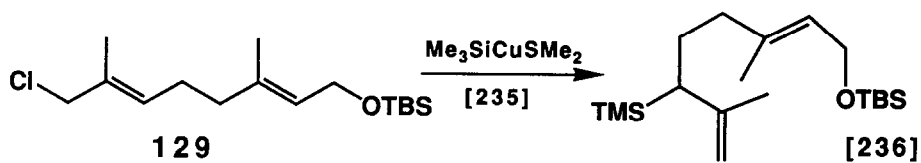

"In situ" generation of the "trichlorosilyl anion" in the presence of 2-chloromethyl-3-chloropropene was used to prepare 2-(acetoxymethyl)-3-(trimethylsilyl)propene. (Eqns. 238 and 239)

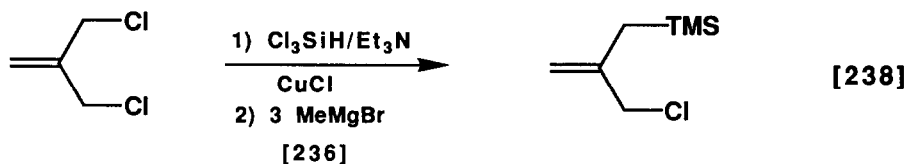

3-(Trimethylsilyl)propionaldehyde was converted to allylsilane **131**. (Eqn. 240)
Selenylation followed by reaction with a Grignard reagent and elimination gives allylsilanes in a stereocontrolled manner. (Eqn. 241)

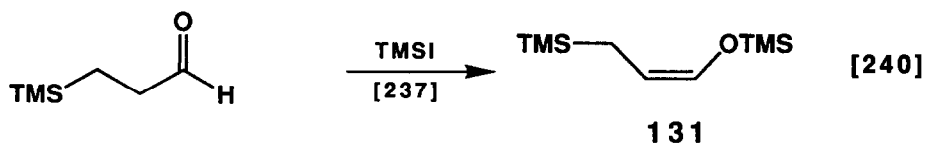

2-Bromo-3-(trimethylsilyl)propene was reacted with cuprous cyanide to give substitution of the bromide. (Eqn. 242)

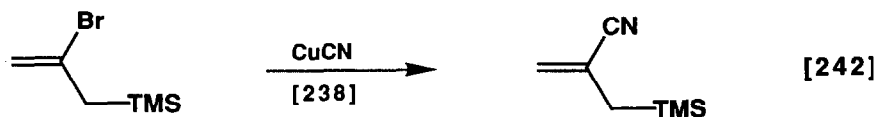

B. Reactions

The reaction of trimethylsilyl azide with allylsilanes in the presence of iodobenzene gives the addition of two azide groups to the double bond. (Eqn. 243) Fluoride-induced elimination gives allyl azides as does the above reaction with boron fluoride etherate added. (Eqn. 244)

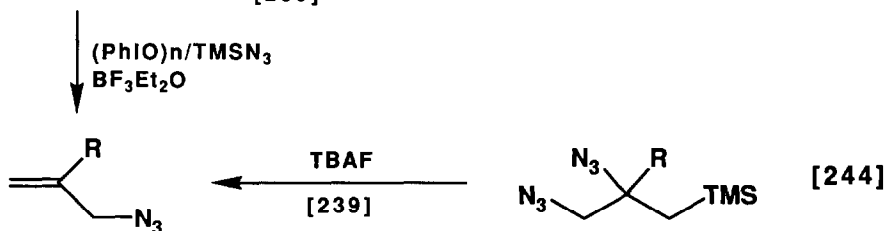
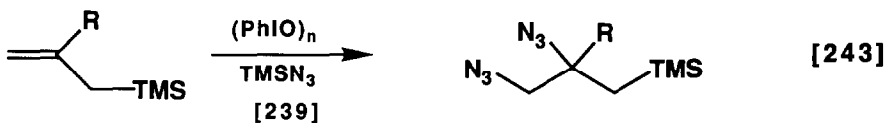

The allylsilane **132** when treated with meta-chloroperbenzoic acid gives a mixture of diastereomeric lactones **133**. (Eqn. 245) Elimination of the trans trimethylsilyl diastereomers gives the hydroxy acid **134**. (Eqn. 246) In a similar reaction amide **135** was converted to lactone **136** and then to **137**. (Eqns. 247 and 248)

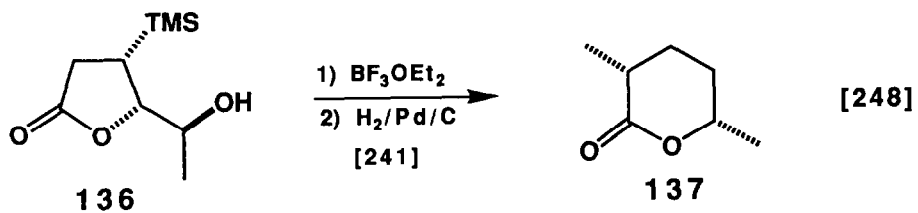
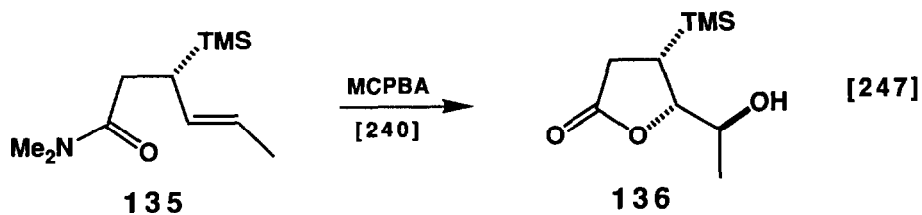
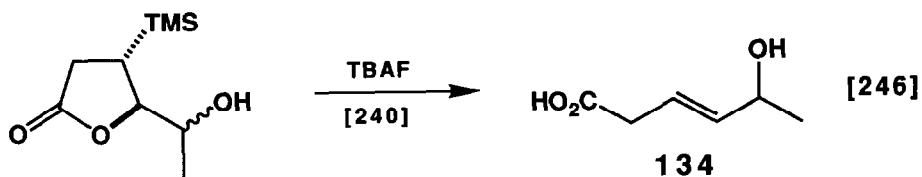
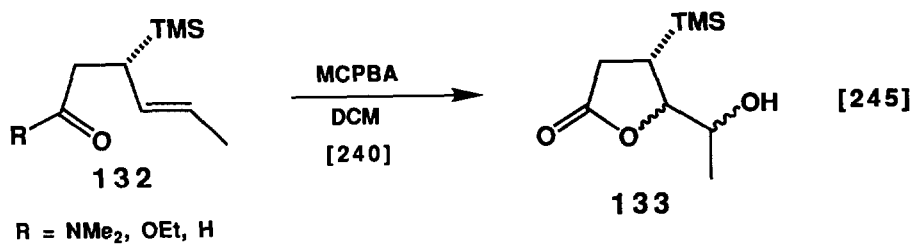

The stereochemistry of the osmium tetroxide bis hydroxylation of allylsilanes was investigated. (Eqn. 249)

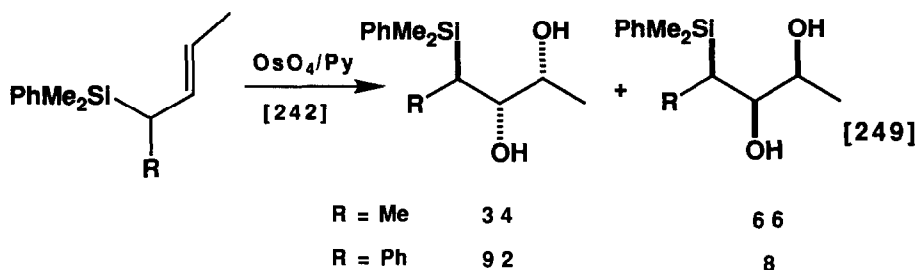

Several allylations *via* the use of allylsilanes were reported. Treatment of the allylsilane complex **138** with fluoride or methoxide ion in the presence of ketones or aldehydes or ethyl acrylate results in allylations. (Eqn. 250) This reaction was also looked at in terms of its stereochemistry. [244] On the other hand, the complex **139** requires a Lewis acid for the allylation to proceed. (Eqn. 251)

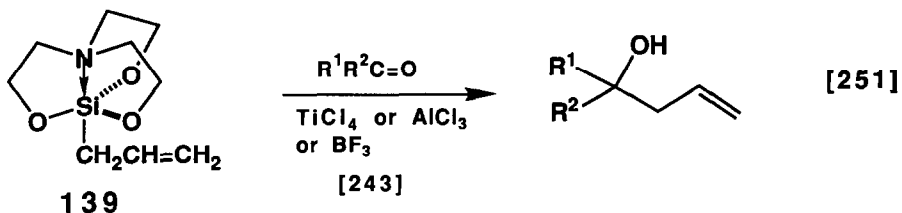
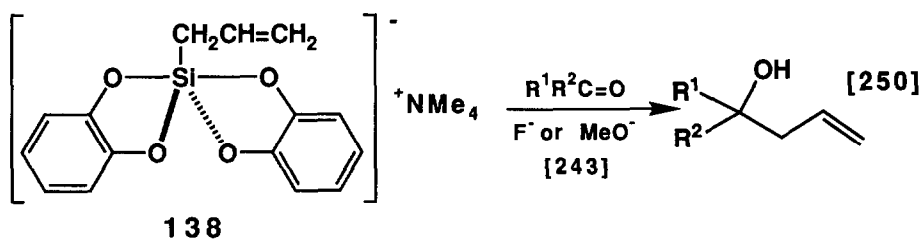

The allylation of carbonyl compounds with allyltrifluorosilanes was shown to be regioselective and chemo- and stereoselective. (Eqn. 252)

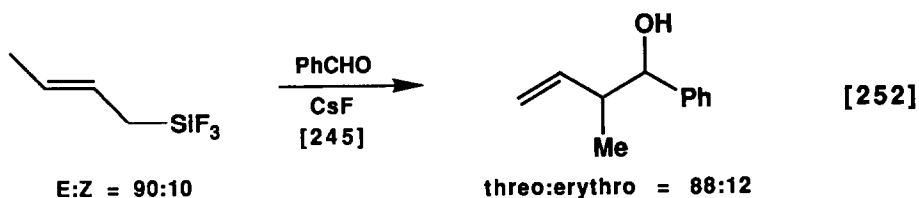

The acetoxy substituted allylsilane **140**, prepared according to Eqn. 253, also undergoes the allylation reaction with α,β -unsaturated carbonyl systems. (Eqn. 254)

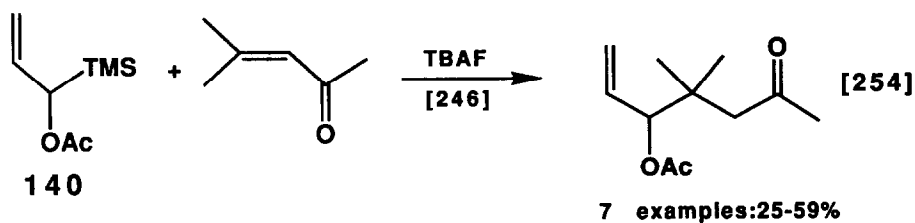
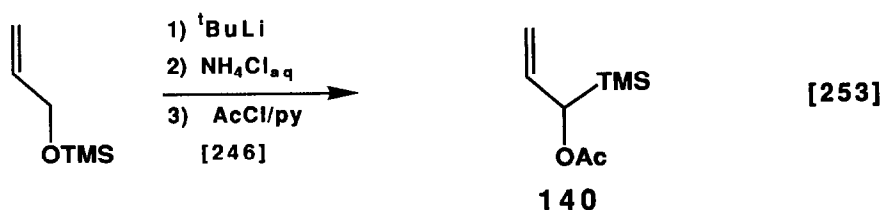

Treatment of bis(trimethylsilyl)ketene acetal **141** with trimethylsilyl fluoride gives rearrangement to allylsilane **142**. (Eqn. 255) The reverse reaction occurs in the presence of fluoride ion. These observations were used to argue for the selective γ -attack in the reactions of **141** with aldehydes with Lewis acid catalysts and the selective α -attack with fluoride ion catalysis. (Eqn. 256)

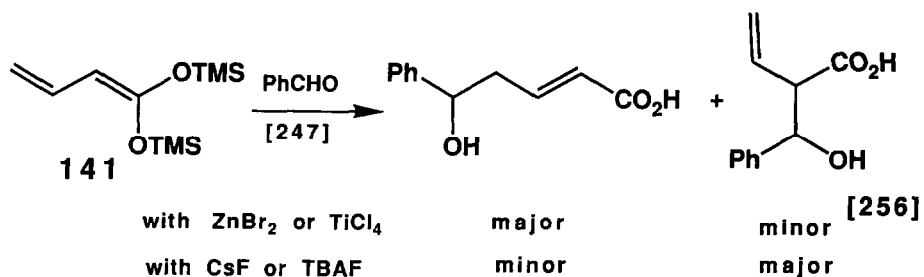
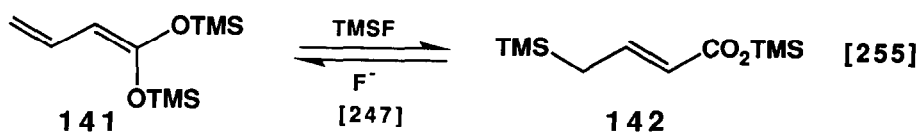

The intramolecular allylation of dienones was investigated. The position of attack depends on the conditions of the reaction with Lewis acid catalysis favoring δ -attack and fluoride ion β -attack. (Eqns. 257 and 258)

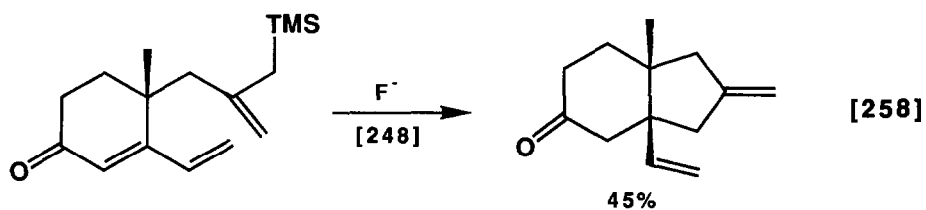
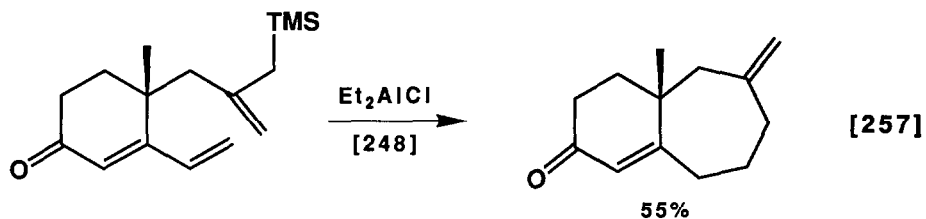

The intramolecular allylation of **143** was accomplished as part of a synthetic route to epoxyclerodatriene. (Eqn. 259) The intramolecular allylation of **144** followed

by trapping of the intermediate enolate ion with chloromethylmethyl sulfide gives

145. (Eqn. 260)

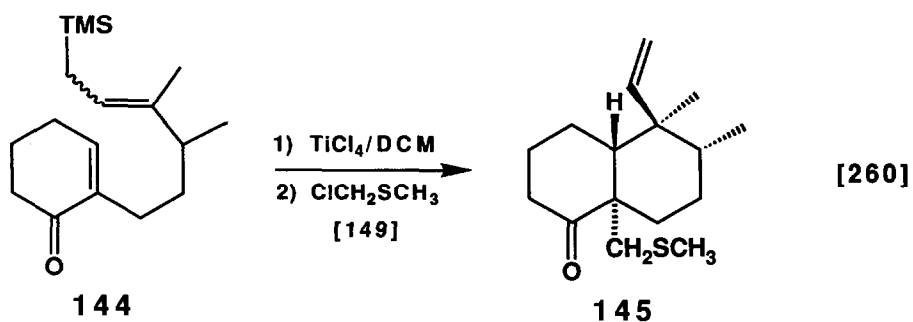
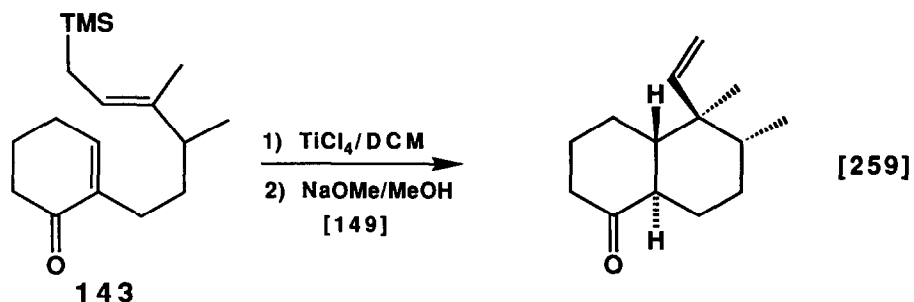

The allylation of the steroidal dienone 146 at the δ -position was shown. (Eqn. 261)

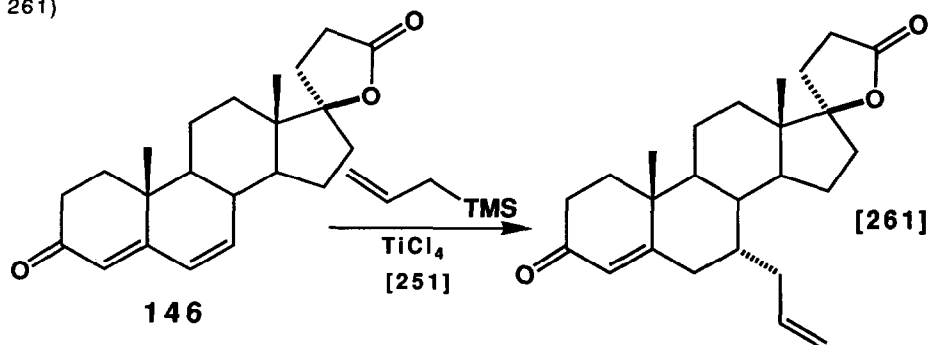

The allylation of α,β -unsaturated ketones with allyltrimethylsilane and trityl perchlorate was reported. (Eqn. 262)

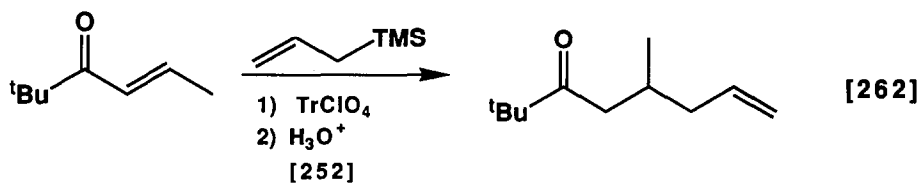

Allylations with a chiral dienylmethylsilane gave good stereoselectivity with isobutyraldehyde. (Eqn. 263)

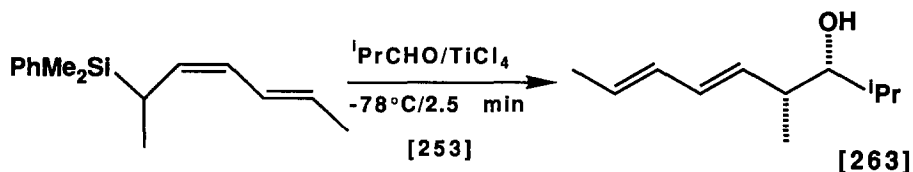

Lactones are the products of the allylation of the aldehyde of the oxo ester **147** after hydrolysis. (Eqn. 264)

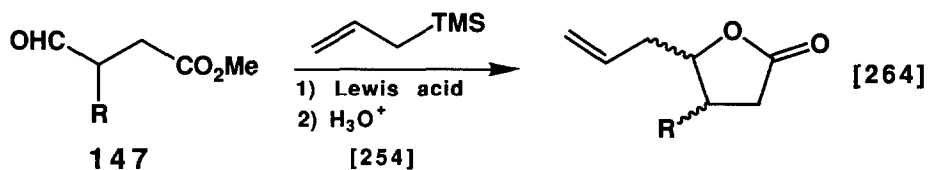

The optically active allylsilane **148** was reacted with butyraldehyde to give product of 46% ee. (Eqn. 265)

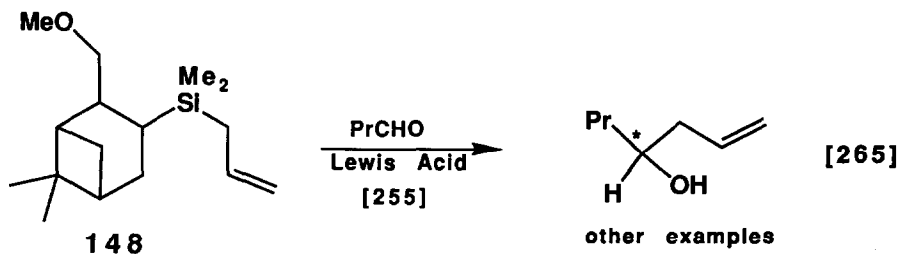

Alkoxydimethylallylsilanes were employed in the allylation reaction where substituted tetrahydropyrans were the products. (Eqn. 266)

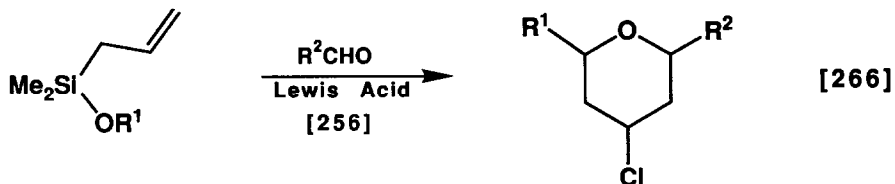

Numerous examples of the allylation of acetals, ketals and related species were reported. The allylation of **149** gave **150**, which was treated with acid to give **151** in a trimethylsilyl-directed Wagner-Meerwein rearrangement. (Eqn. 267)

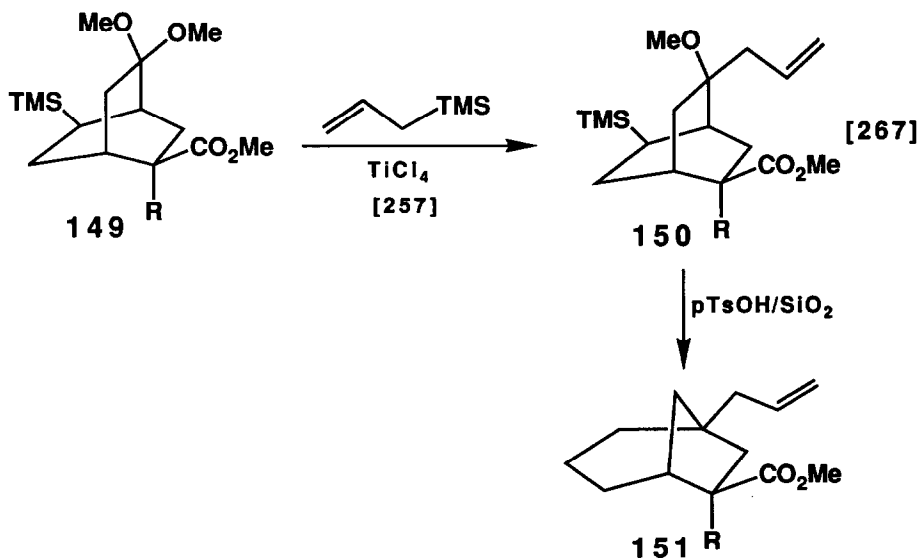

The allylation of **152** was shown to give more anti than syn product. (Eqn. 268)

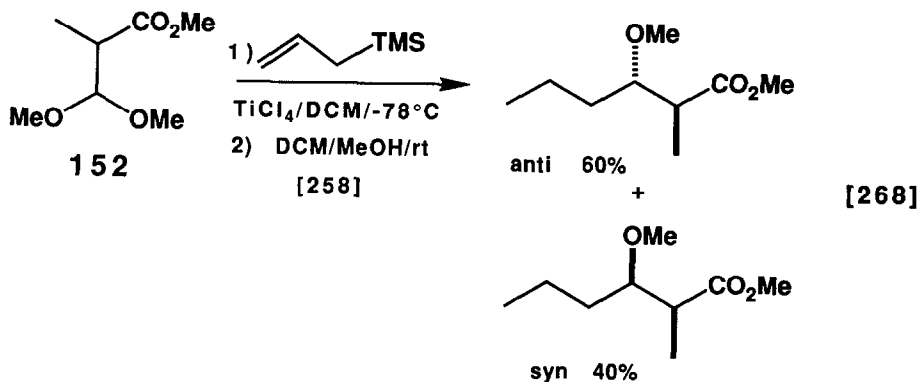

The interesting reaction of allylsilane **153**, which itself contains a dimethyl acetal, with the dimethyl acetal of dimethyl formamide gives the fulvene **154**. (Eqn. 269)

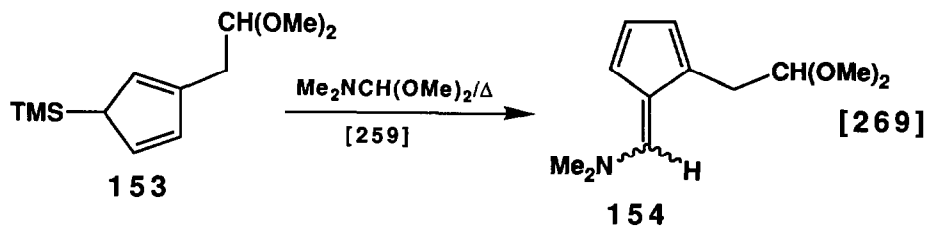

BOC protected amino sugars can be allylation with allyltrimethylsilane. (Eqn. 270) In a similar situation **155** was allylated to give optically active **156**. (Eqn. 271)

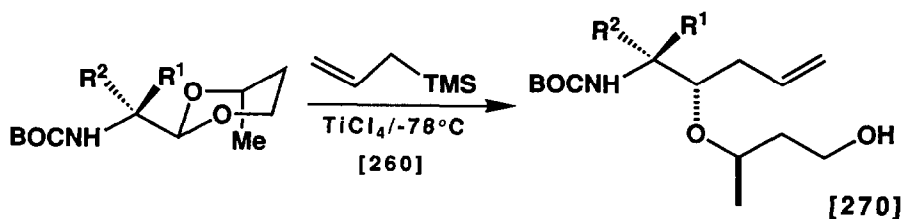

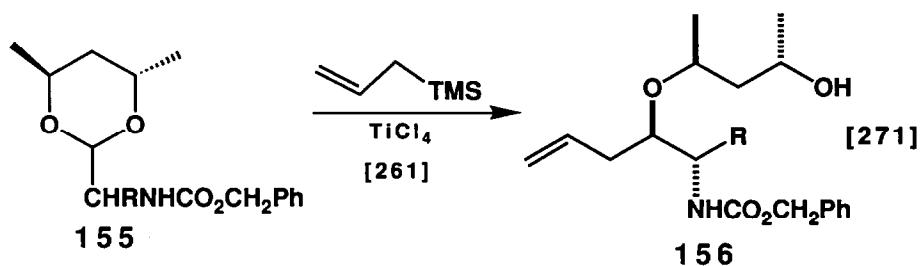
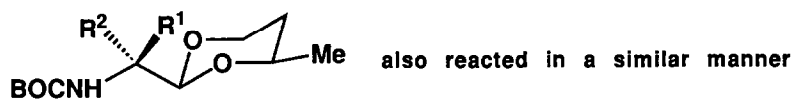

The intramolecular allylation of acetal **157** was accomplished to give two diastereomers. (Eqn. 272) The intramolecular allylation of **158** in the presence of a silyl enol ether allowed for the formation of bicyclic skeletons. (Eqn. 273) The homolog **159** reacts in a similar manner. (Eqn. 274)

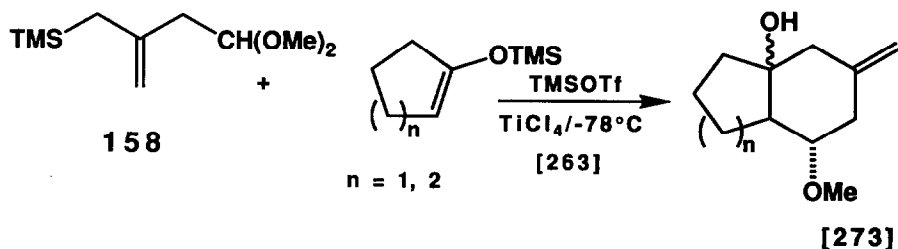
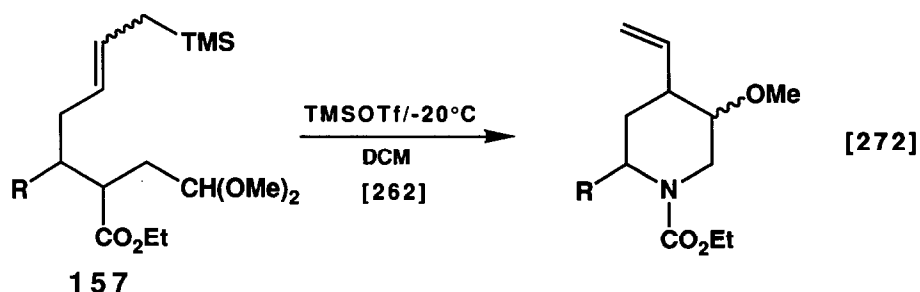

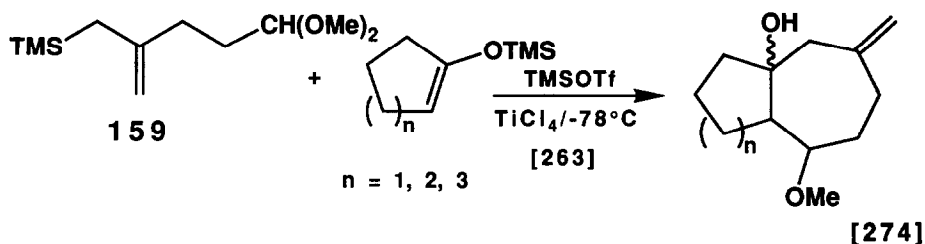

The reaction of allyltrimethylsilane with hemiacetals is also possible. (Eqn. 275) Similar reactions occurred with bis(trimethylsilyl)acetylene and 3-trimethylsilyl-acetylene.

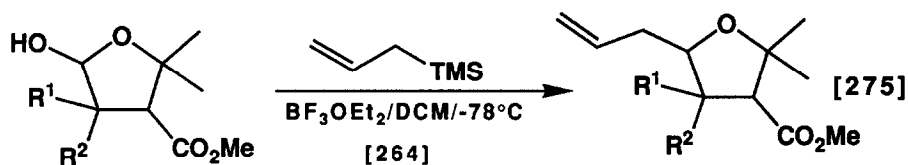

Ribofuranosyl fluorides were shown to react with allyltrimethylsilane. (Eqn. 276)

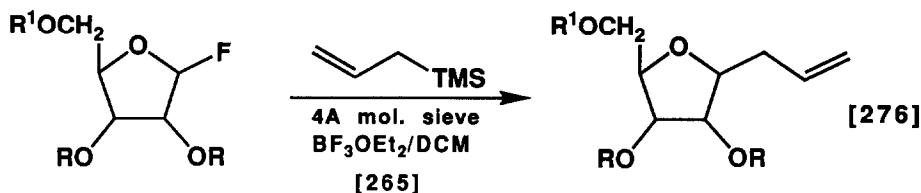

The asymmetric allylation of aldehydes was accomplished by first reacting the aldehyde with an alkoxytrimethylsilane in which the alkoxy group is optically active and then reacting the resulting silylated hemiacetal with allyltrimethylsilane in the presence of a Lewis acid. (Eqns. 277 and 278)

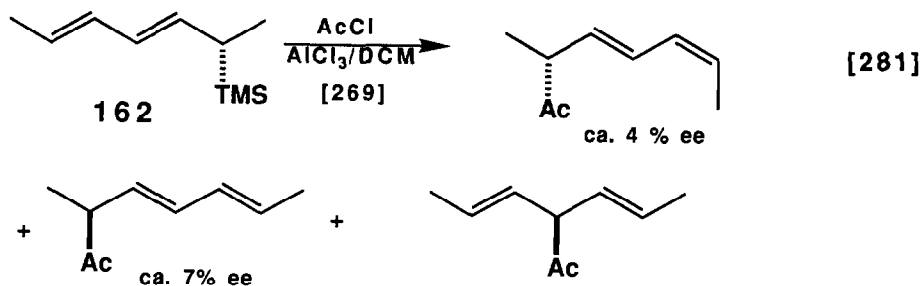

The asymmetric allylation of α -keto amides derived from (*S*)-proline esters was reported. (Eqn. 282)

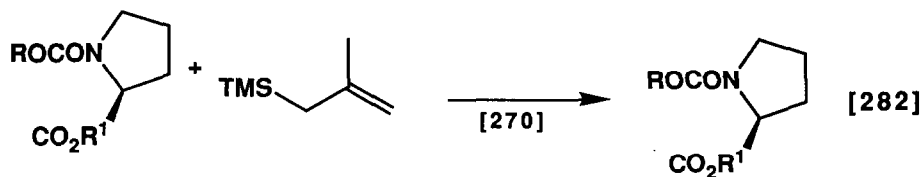

The reaction of allylsilanes with diketene gives allylated 1,3-diketones in moderate yields. (Eqn. 283)

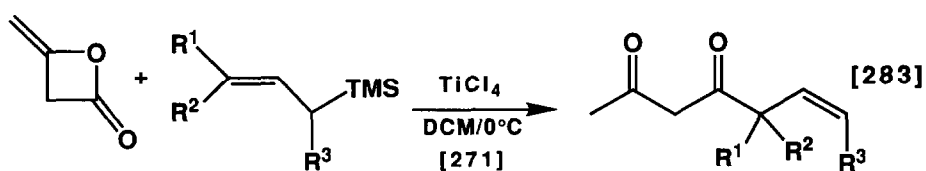

Allylsilanes were employed in the allylation of several other systems. Amines were intramolecularly allylated through an 'in situ' generated imine intermediate as shown in Eqns. 284 and 285.

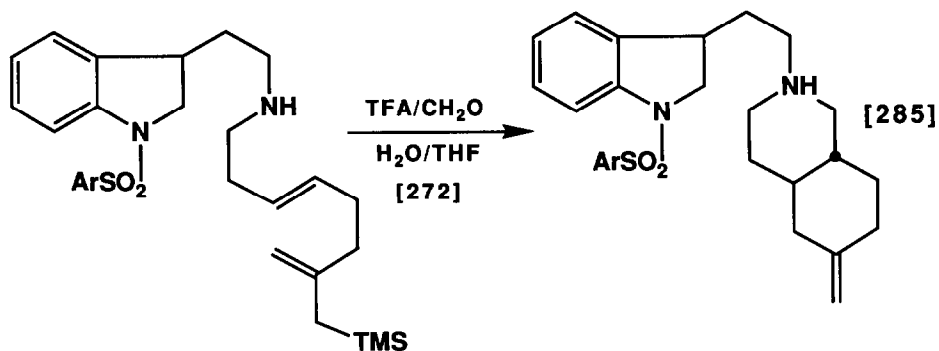
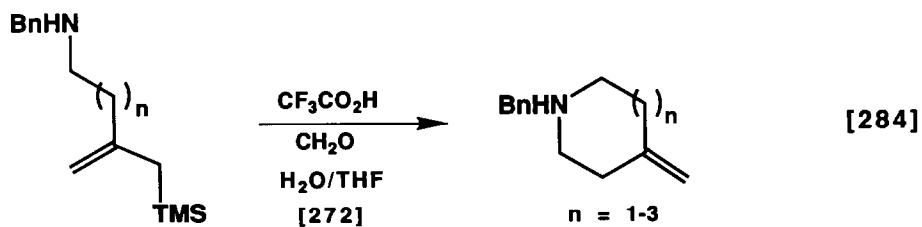

The allylsilyl group in **162** was used in a biomimetic polyene cyclization. (Eqn. 286)

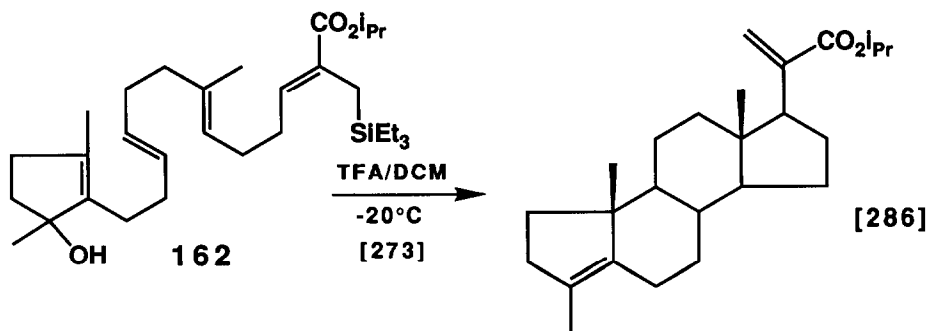

Vinylsulfides were allylated in excellent yields. (Eqn. 287)

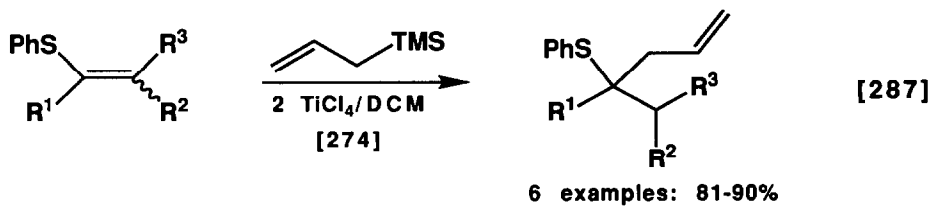

The sulfone substituted epoxy allylsilane **163** was subjected to an intramolecular allylation process. (Eqn. 288) Only one diastereomer cyclized, however.

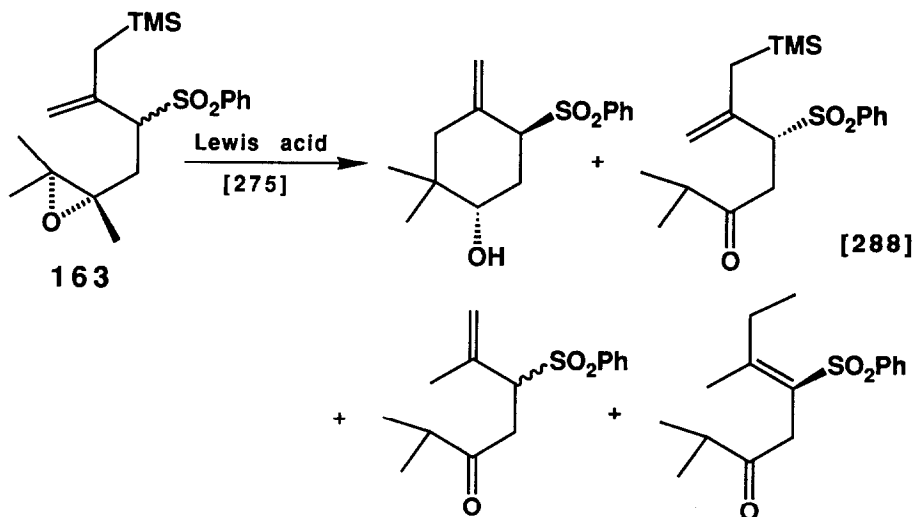

Tertiary chlorides were allylated with allyltrimethylsilane. (Eqn. 289)

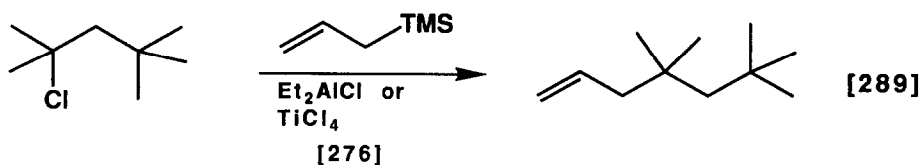

Nitrones can be allylated with allyltrimethylsilane in the presence of trimethylsilyl triflate. (Eqn. 290) This reaction was also reported in an intramolecular sense.

(Eqn. 291)

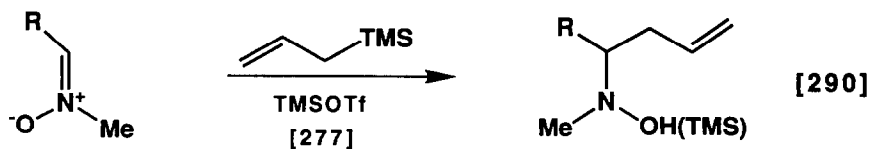

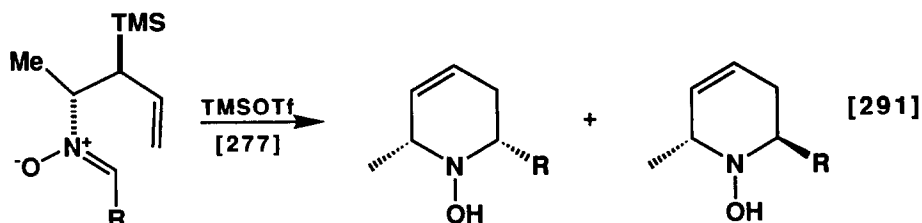

The allylation of α -nitro sulfides with allyltrimethylsilane to give homoallylic thio ethers was reported. (Eqn. 292)

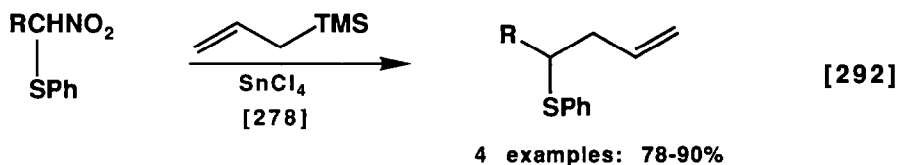

The oxidative allylation of β -(methoxymethyl)styrene was reported to occur in good yield. (Eqn. 293)

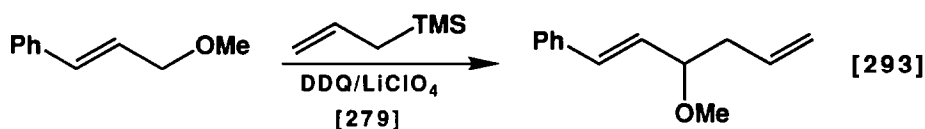

The reaction of allyltrimethylsilane with iodosobenzene in the presence of aryl hydrocarbons gives allylation of the aromatic hydrocarbon *via* an allylated hypervalent iodine intermediate. (Eqn. 294)

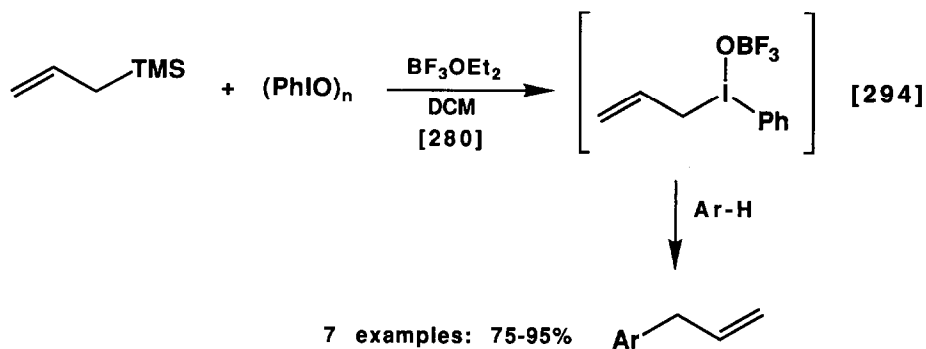

The allylation of para-dicyanobenzene (or ortho-dicyanobenzene) with allyltrimethylsilane was shown to proceed without problem. (Eqn. 295)

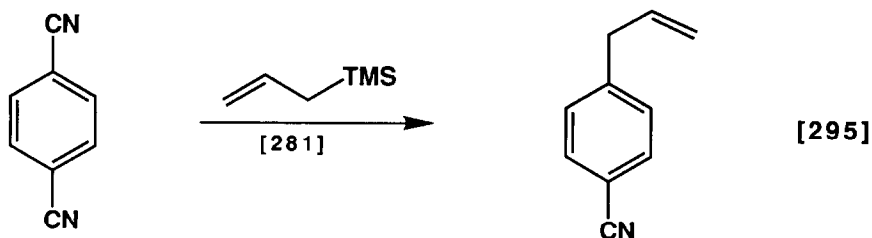

Allylsilanes were involved in cycloadditions as well. The Trost reagent **164** was used in [3+2] cycloadditions with cyclohexenones. (Eqn. 296) A full account of the reaction of **165** with activated olefins in [3+2] cycloadditions was reported. (Eqn. 297) Certain criteria applied to the concertedness of this class of [3+2] cycloaddition reaction were published. [284]

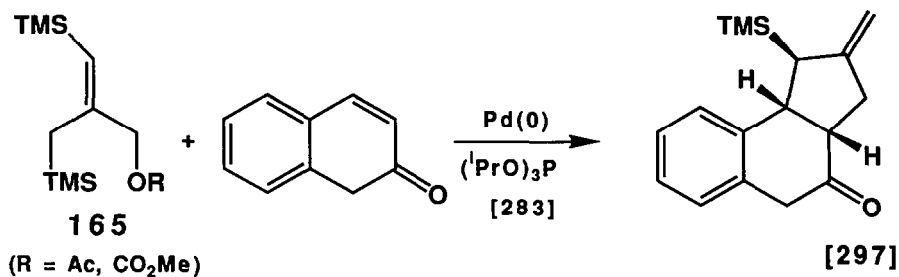
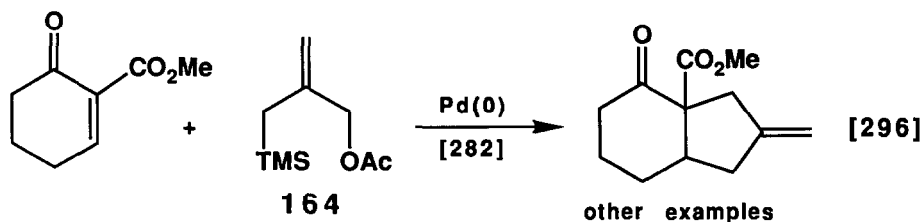

2-[(Dimethylamino)methyl]-3-[(trimethylsilyl)methyl]-1,3-butadiene was shown to react with enolate ions setting up an intramolecular allylation of a ketone. (Eqns. 298 and 299) A reversal of the sequence of events has the allylation of the ketone first followed by intramolecular displacement of the leaving group. (Eqns. 300 and 301)

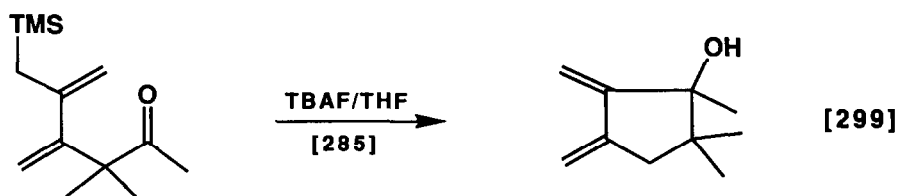
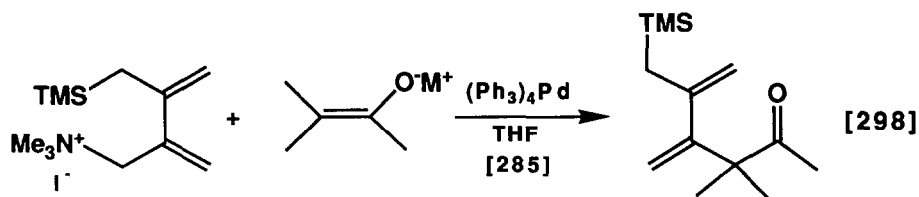

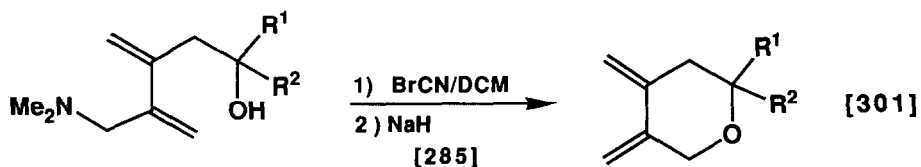
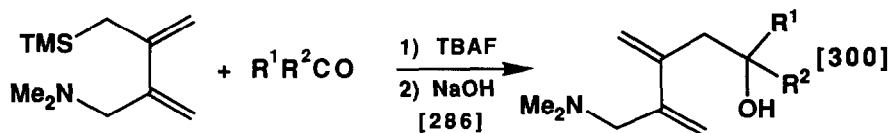

Reaction of 1,3-cyclohexane diones with allylsilanes gives the bicyclic substituted dihydrofurans. (Eqn. 302)

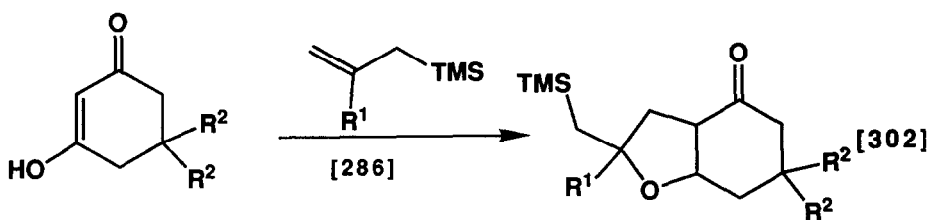

Nitrones react with allylsilanes to give [3+2] cycloaddition products with retention of the trimethylsilyl group. (Eqn. 303)

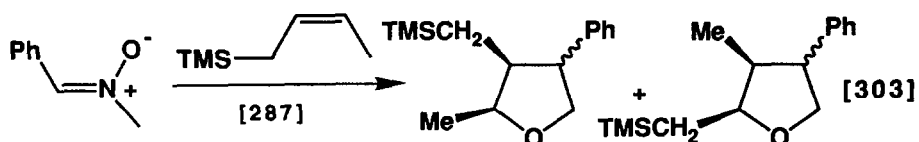

A β -chloroallylsilane was subjected to radical cyclization. The major product was that of straight reduction of the chloride with very little cyclization. (Eqn. 304)

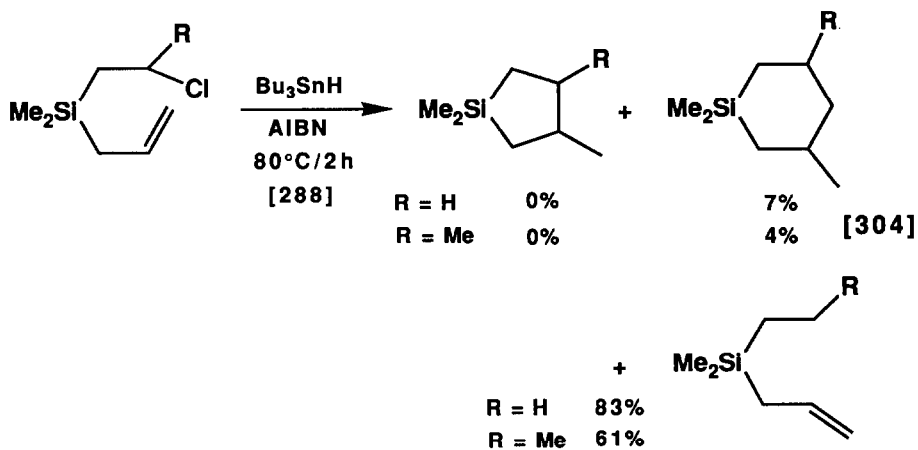

Singlet oxygen and phenyltriazolinedione were both reacted with (Z) allylsilane **166**. (Eqns. 305 and 306) The (E) isomer of **166** reacted in the same way.

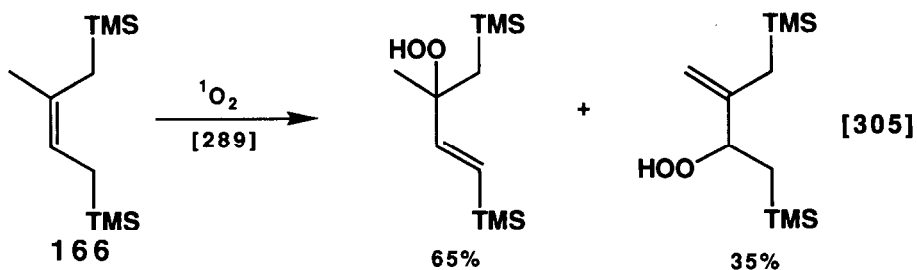

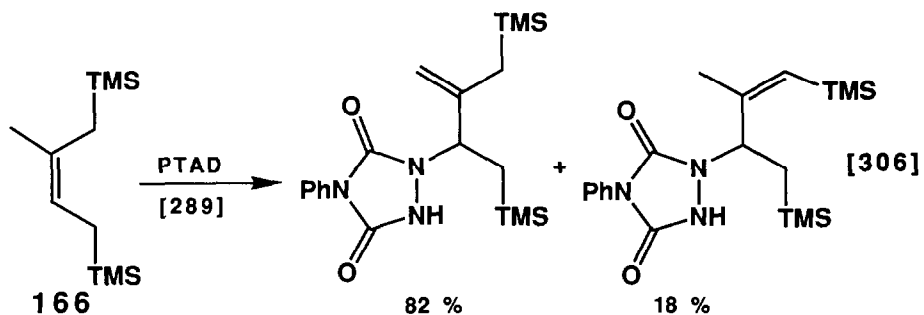

Allyltrimethylsilane itself was reacted with singlet oxygen and the results compared to those for the reaction of singlet oxygen with tert-butyl ethylene. (Eqn. 307)

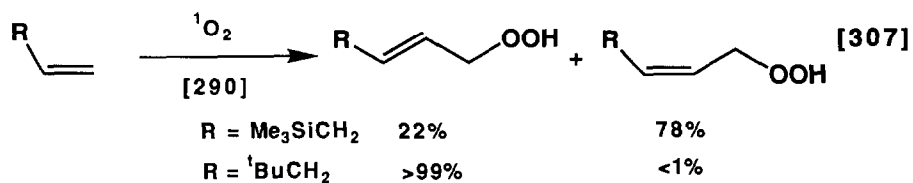

Deprotonation-alkylation of various allylsilanes showed a greater tendency for γ -alkylation than for α -alkylation. (Eqn. 308)

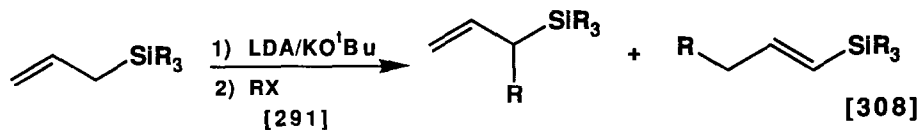

Lithium-silicon exchange of **167** followed by alkylation gave the 2,2-dialkyl sulfolenes. (Eqn. 309)

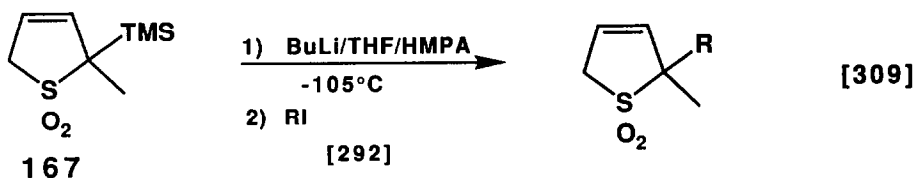

C. Other Studies

The mass spectra of **168** was reported.

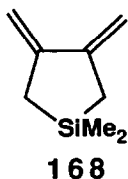

X. PROPARGYLSILANES

Only reactions and no preparations of propargylsilanes were reported. The reaction of propargylsilanes with boron fluoride etherate acetic acid complex gives allenes *via* a protodesilylation. (Eqn. 310) Cyclization is also possible if an hydroxyl group is present. (Eqn. 311) The presence of a trimethylsilyloxy group leads to a vinylsilane. (Eqn. 312)

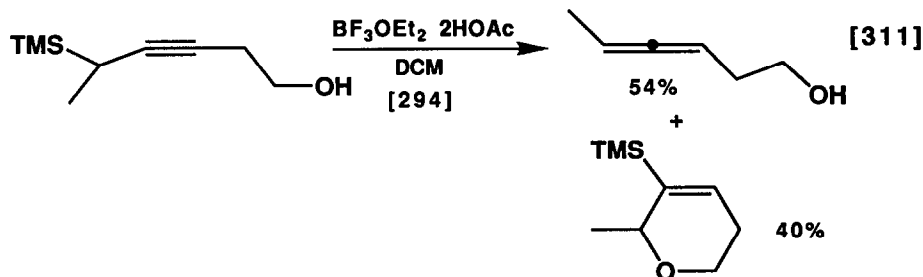
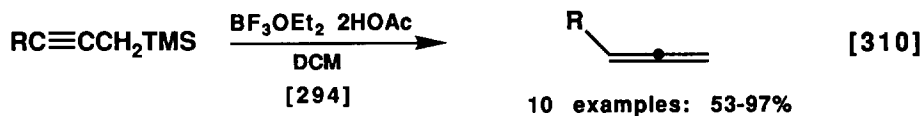

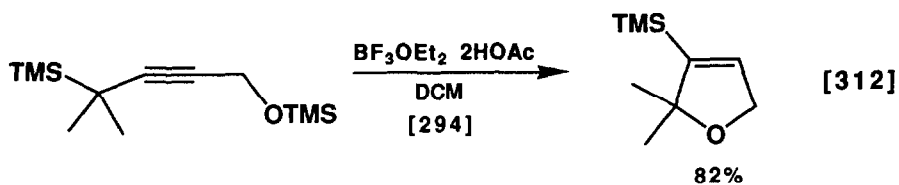

Propargylsilanes were shown to react with hemiacetals to give allenylation. (Eqn. 313)

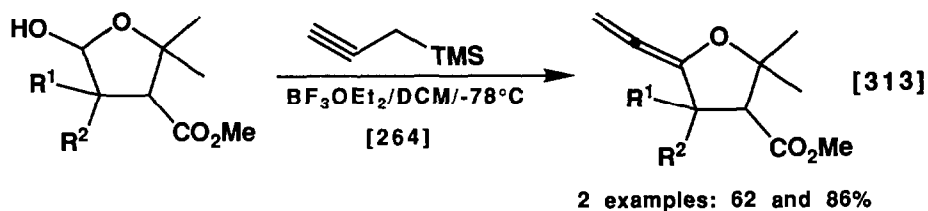

An intramolecular version of this same general reaction was accomplished with **169** to give bicyclic systems. (Eqn. 314) A similar cyclization was accomplished with acyclic propargylsilanes of the general structure **170**. (Eqn. 315)

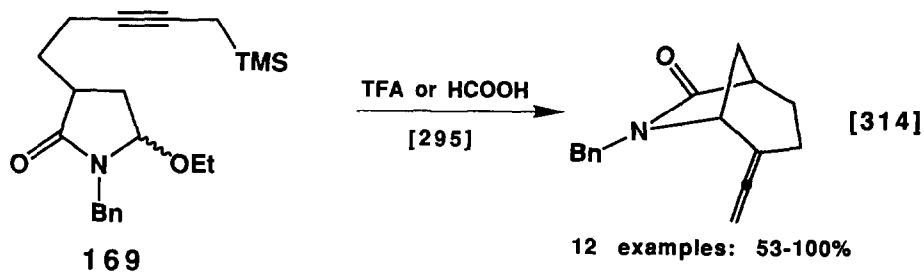

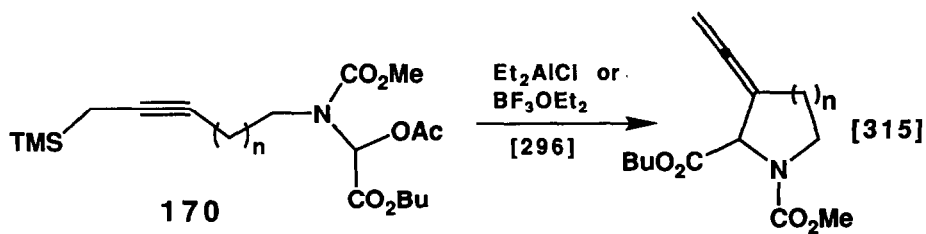

Intramolecular allenylations with the reaction of propargylsilanes on enones was reported. (Eqn. 316) Dienone versions of these same systems reacted preferentially at the β -position of the enone or not at all. (Eqns. 317 and 318)

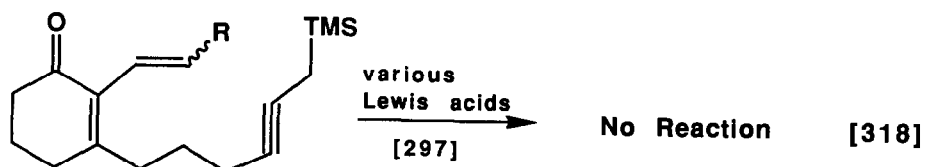
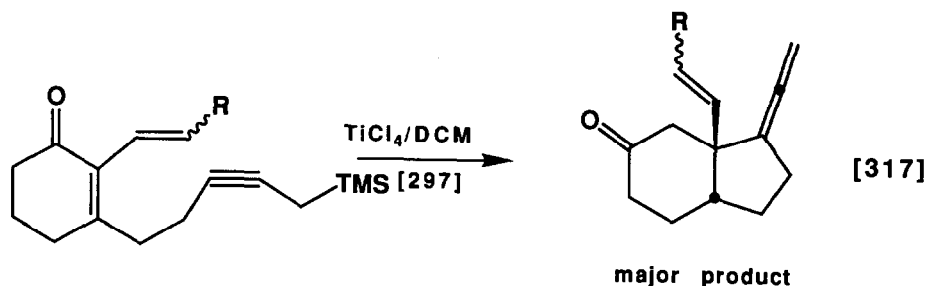
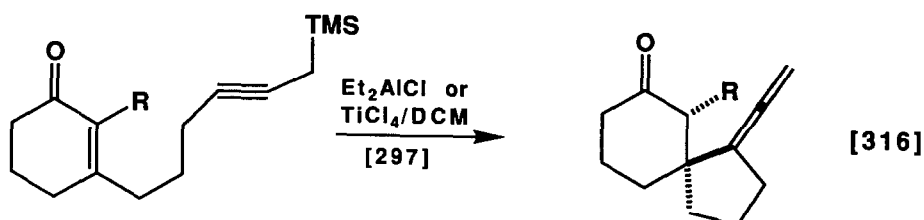

The intramolecular reaction of the propargylsilyl group and an amine with formaldehyde leads to cyclizations. (Eqn. 319)

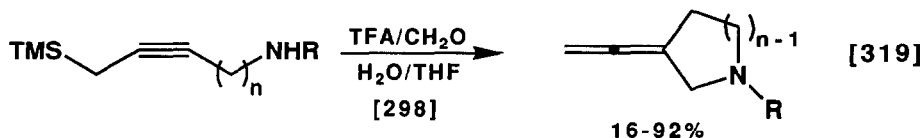

XI. BENZYL SILANES

A. Preparation

The reaction of 1,3,5-tris(dichloromethyl)benzene with a mixture of magnesium and trimethylchlorosilane in tetrahydrofuran results in a good yield of 1,3,5-tris[bis(trimethylsilyl)methyl]benzene. (Eqn. 320) It was used to prepare a stable thiosulfinyl system.

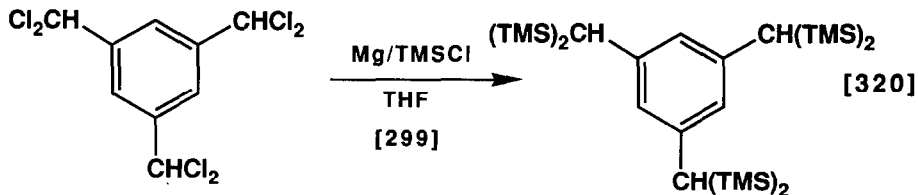

The deprotonation-trimethylsilylation of various benzothiazoles was reported. (Eqn. 321) These materials were used to study the stereoselectivity of the reaction with aldehydes. (Eqn. 322)

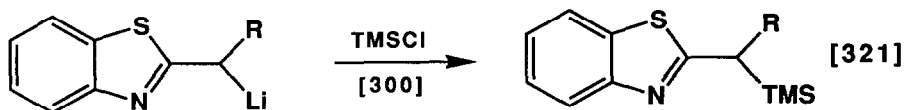

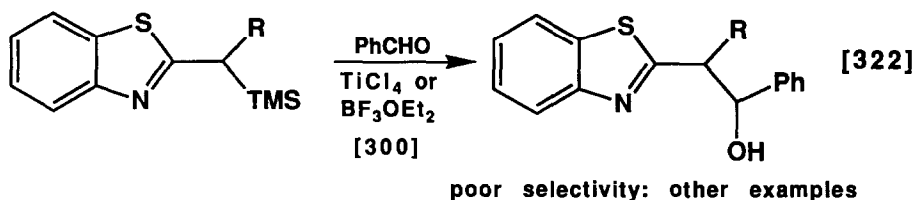

The lithium reagent from benzyl phenyl sulfide was reacted with dimethyl-dichlorosilane to give **171** (Eqn. 323), which in turn was reacted with lithium dispersion and then trimethylmetal chlorides (or dimethylmetal dichlorides) to give **172** or **173** (Eqns. 324 and 325).

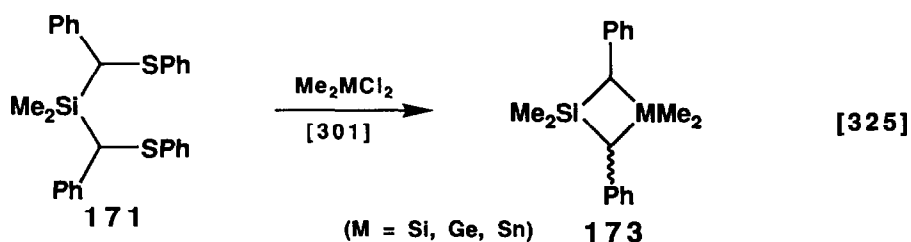
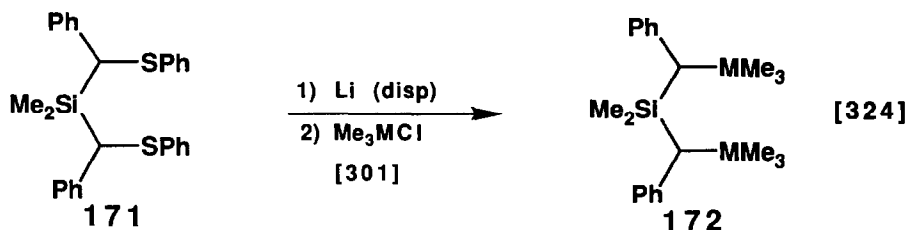
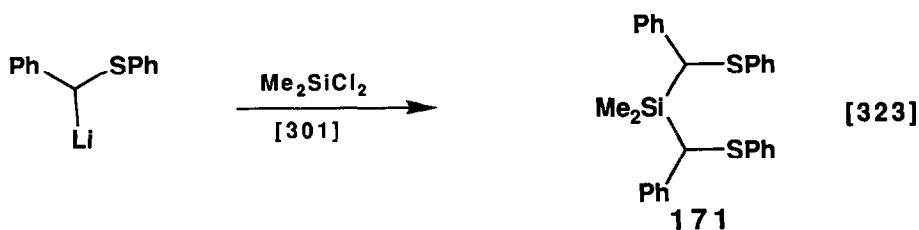

Benzyl alcohol was reacted with methyl lithium and then hexamethyldisilane to give benzyltrimethylsilane. (Eqn. 326) Phenethyl alcohol gives the same reaction.

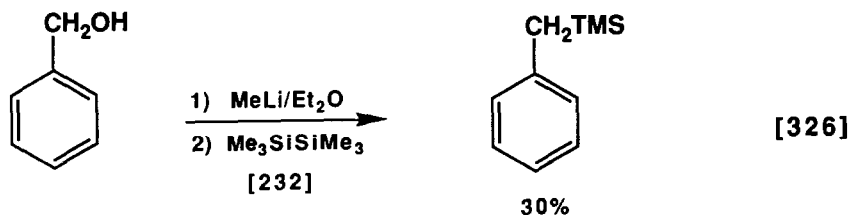

The functionalized benzylsilane **174** was reacted with toluene to give electrophilic aromatic substitution and benzylsilane **175**. (Eqn. 327) The benzylsilane **174** also reacts with olefins. (Eqn. 328)

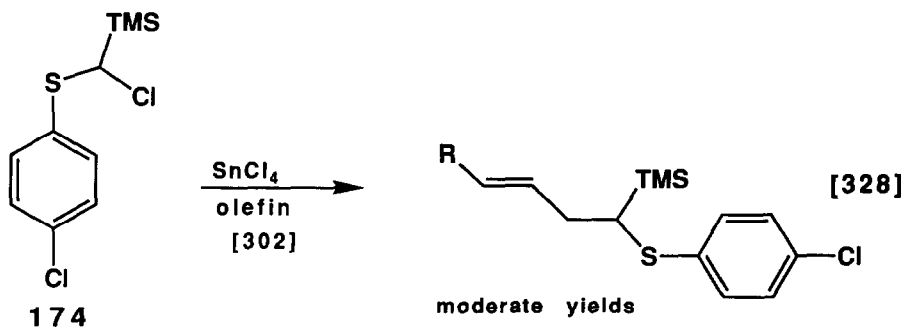
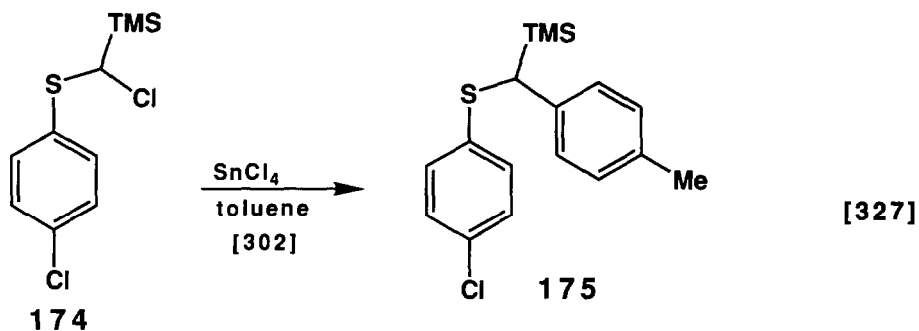

B. Reactions

Benzyltrimethylsilane was reacted with iodine bromide in carbon tetrachloride to give para-bromination, but in acetonitrile to give benzyl bromide. (Eqns. 329 and 330)

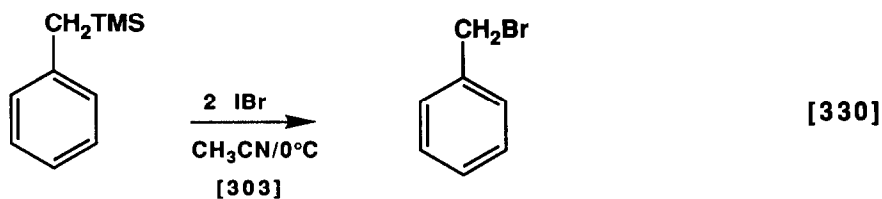
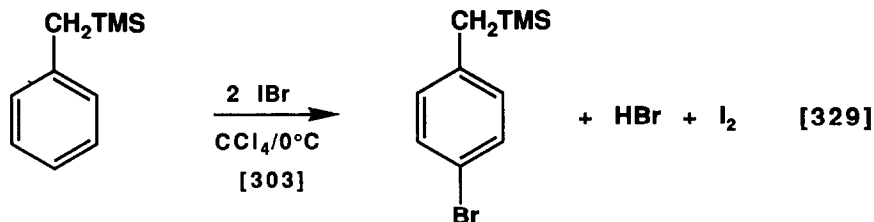

Benzyltrimethylsilane was shown to oxidatively couple with aryl hydrocarbons in the presence of a transition metal catalyst. (Eqn. 331)

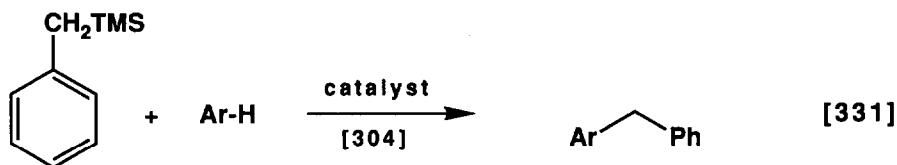

(catalyst = MoCl_5 , AlCl_3 , WCl_6)

Aryl nitriles reacted photolytically with benzylsilanes to give displacement of a nitrile group and introduction of the benzyl group in the ortho position. (Eqn. 332)

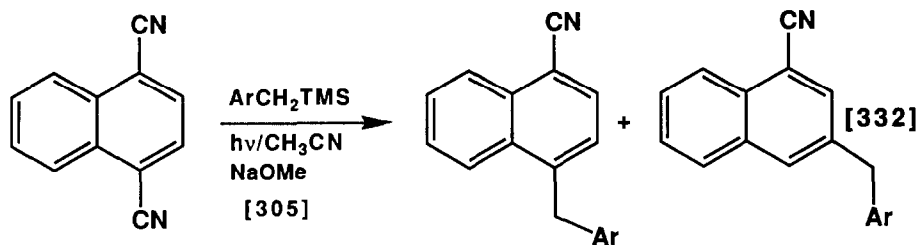

Benzylsilane **176** was reacted with tetra-*n*-butylammonium fluoride (TBAF) to give *o*-quinodimethane **177**. (Eqn. 333)

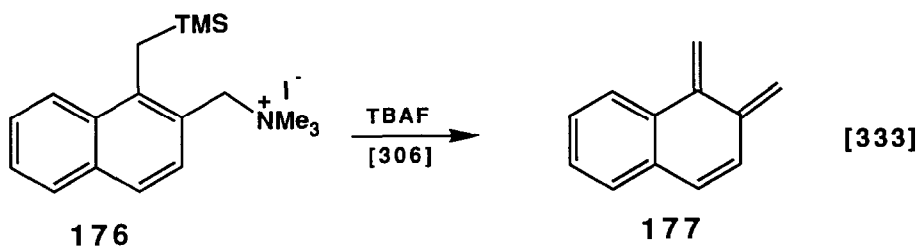

The intramolecular cyclization of benzylsilanes with iminium salts continued to be an excellent entry into alkaloid systems. Some of the examples are given in Eqns. 334 and 335. The scope, limitation and mechanistic aspects of this highly useful reaction have been discussed. [309]

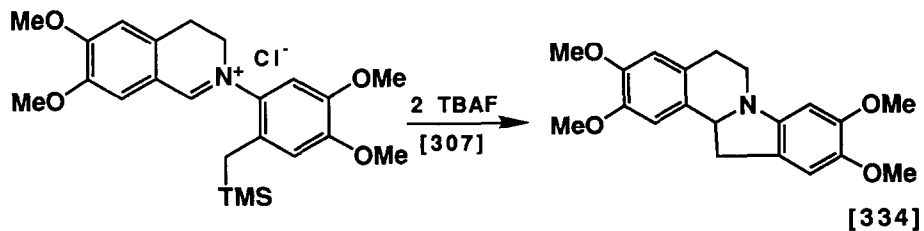

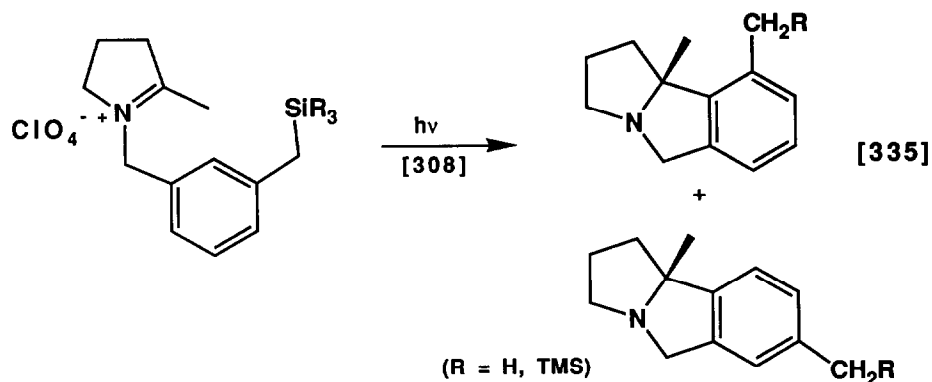

C. Other Studies

A quantum chemical study of the influence of benzyl systems on the stability of their para cations was carried out. [310] An x-ray crystal structure of 1,1-bis-(triisopropylsilyl)cyclopropabenzene was reported. [311] The two triisopropylsilyl groups are related by C_2 symmetry. The C=C of the cyclopropene portion is stretched due to the steric influence of the triisopropylsilyl groups. The rates of hydrogen abstraction from benzylsilanes was investigated. It was concluded that the trimethylsilyl group has only a small directing effect towards its α -position. [312]

XII. α -FUNCTIONAL ORGANOSILANES

A. Preparation

Chloromethyltrimethylsilane was reacted with the potassium salt of **178** to give the α -amidosilane **179**. (Eqn. 336)

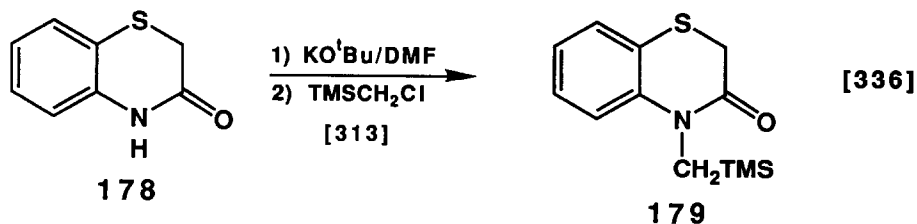

Deprotonation-trimethylsilylation of **180** leads to α -sulfonylsilane **181**. (Eqn. 337) Treatment of **182** with 3 equivalents of butyllithium followed by trimethylsilylation of the anion gives cyclopropane **183**. (Eqn. 338) Double deprotonation-trimethylsilylation of benzylimine **184** gives **185**. (Eqn. 339)

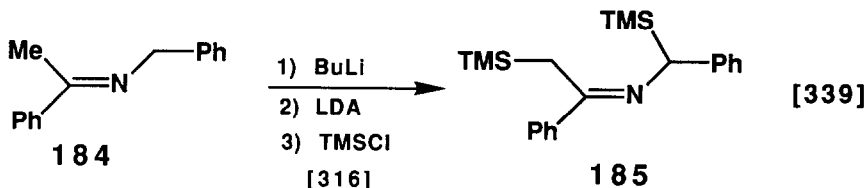
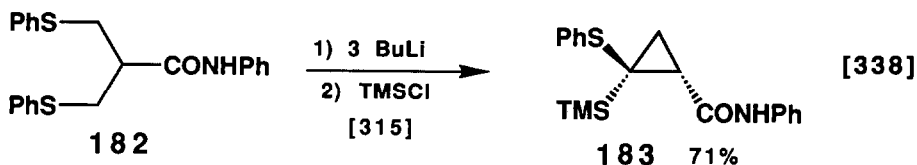
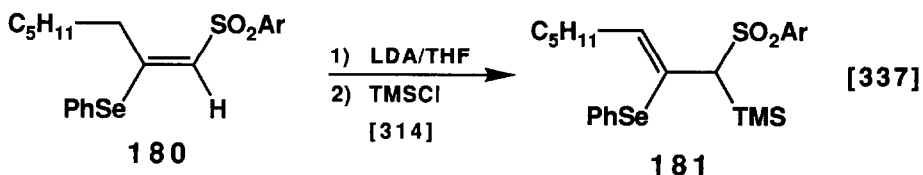

It was found that it is possible to 'in situ' trimethylsilylate carbenoids as they are formed. Thus treatment of benzyl chloride with lithium diisopropyl amide in the presence of trimethylchlorosilane gives the α -chlorobenzyltrimethylsilane in good yield. (Eqn. 340) Benzyl bromide and allyl bromide were similarly reacted. (Eqns. 341 and 342)

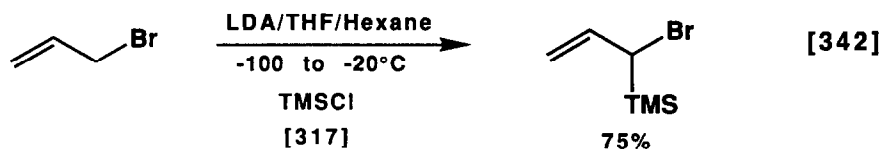
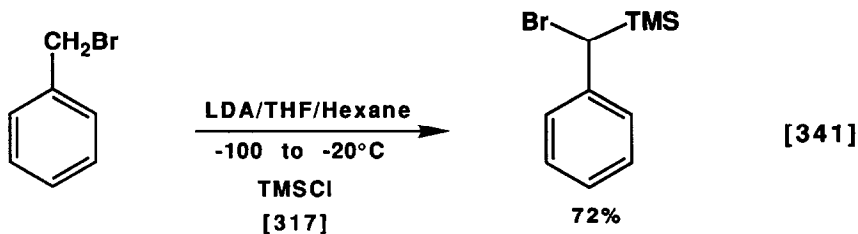
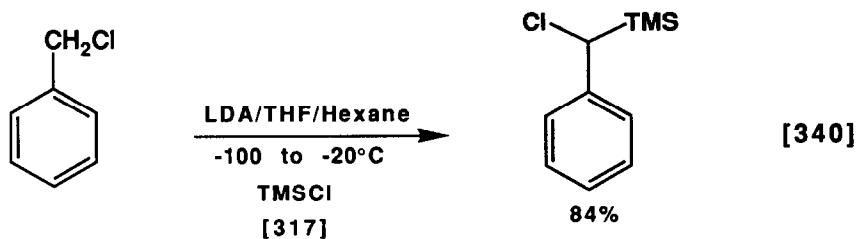

α -Hydroxyalkylsilanes were prepared by a reverse Brook rearrangement. Treatment of an aldehyde with tributyltinlithium and then trimethylsilyl nitrile gives the α -trimethylsiloxy tin compound, which when subjected to reaction with butyllithium leads to α -hydroxyalkylsilanes. (Eqn. 343)

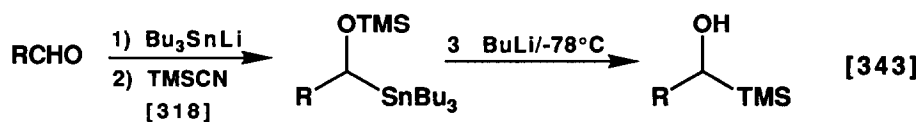

(ketones, Et_3Si and ${}^t\text{BuMe}_2\text{Si}$ also employed)

It was reported that diazomethane reacts with trimethylsilyl iodide (or triflate) to give the product of insertion. (Eqn. 344) Trimethylsilyl bromide will react as well, but only in the presence of zinc bromide. (Eqn. 345)

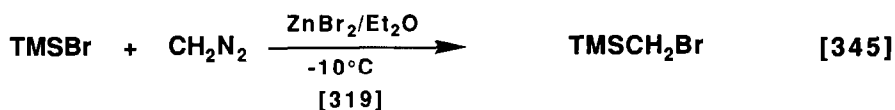
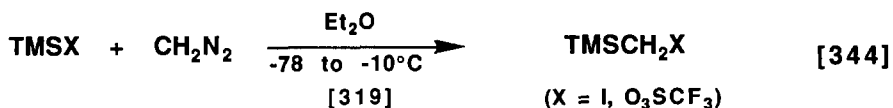

The reaction of the α -functional silane **186** with sulfuryl chloride (Eqn. 346) or bromine (Eqn. 347) gives the corresponding α -halosilanes. These were reacted with β -ketosilanes to give β -silyl- β -methoxyketones. (Eqn. 348) These could be converted to the β -silyl- α,β -unsaturated ketones. (Eqn. 349)

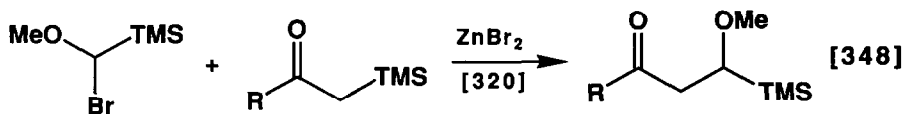
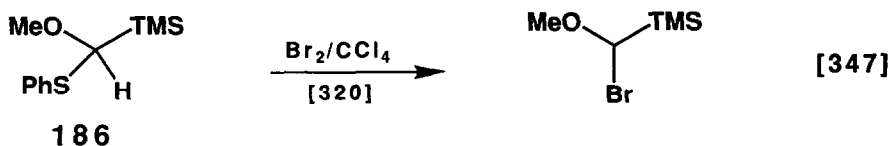
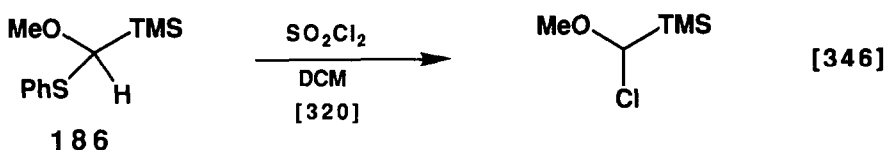

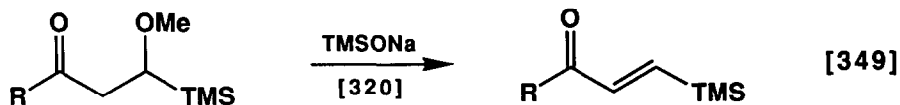

Heating of chloromethyltriethoxysilane in the presence of di-tert-butyl peroxide gives bis(triethoxysilyl)chloromethane. (Eqn. 350)

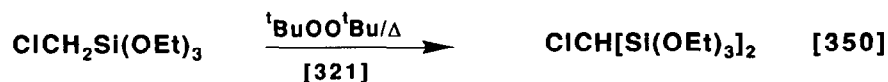

B. Reactions

Chloromethyl and other chloroalkylsilanes containing an unsaturation were amino-mercurated to give addition of the amine to the double bond and in some cases cyclization. (Eqns. 351-354)

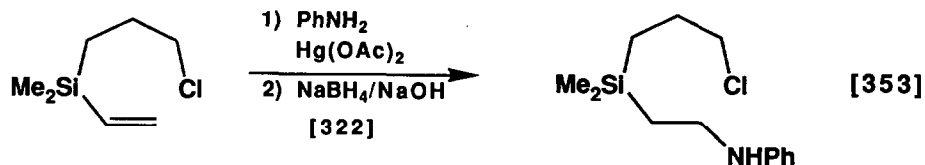
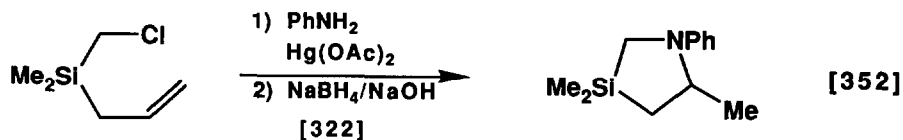
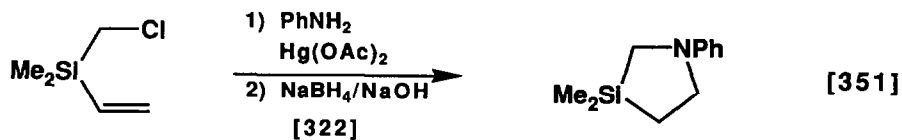

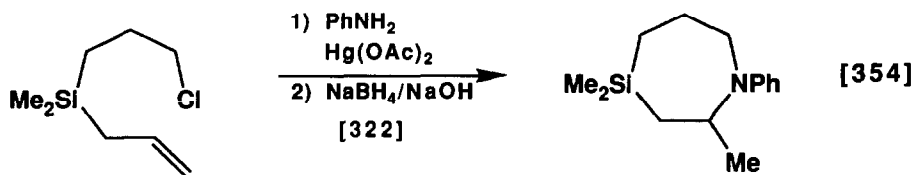

Reaction of alkyl halides or tosylates with N-trimethylsilylmethyl imine **187** gives the simple, less stable imine **188**. (Eqn. 355) This was cycloadded to electron deficient olefins.

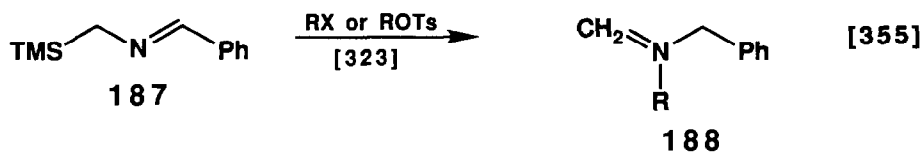

Thioaryloxymethylsilanes were shown to react with alcohols under Ni(III) mediated electrolysis to give alkoxylation of the Si-C bond. Representative examples are given in Eqns. 356 and 357. Direct conversion to the acetal is also possible. (Eqn. 358)

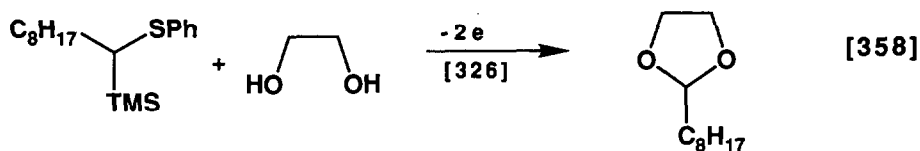
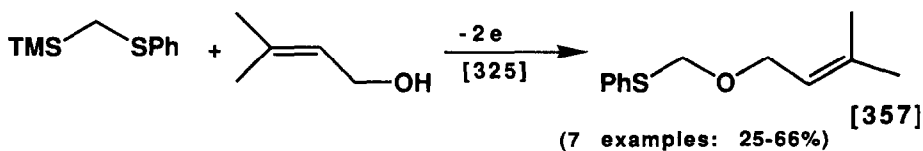
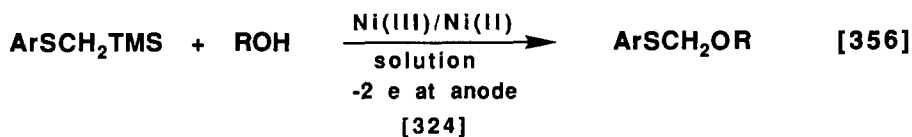

Diethylaminomethyltrimethylsilane was photochemically added to enones to give β -diethylaminomethyl (or γ -diethylamino) ketones. (Eqn. 364) It is also possible that the reaction occurs *via* cleavage of a C-H bond rather than the C-Si bond.

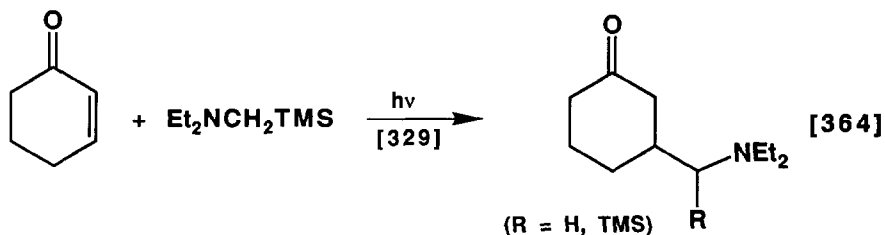

The reaction of several α -functional silanes with fluoride ion in the presence of a suitable electrophile continued its wide acceptance as convenient methodology for a number of transformations. α -Trimethylsilylphosphonic acid esters were treated with fluoride ion in the presence of aldehydes and ketones to give Wittig-type products. (Eqn. 365) A variety of N-trimethylsilylmethylaziridines were reacted with aldehydes and ketones in the presence of fluoride ion. (Eqn. 366)

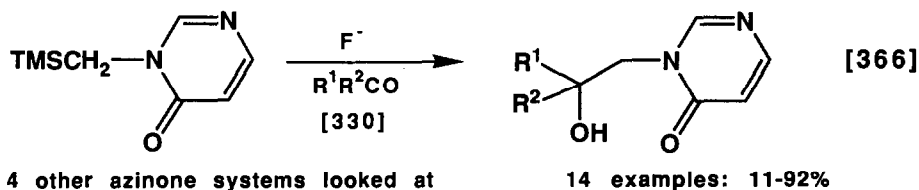
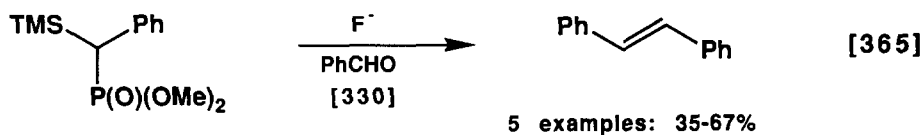

N-Trimethylsilylmethyl-2-pyridone was reacted with aldehydes with fluoride ion mediation. (Eqn. 367) The reaction with acid chlorides does not require a catalyst. (Eqn. 368)

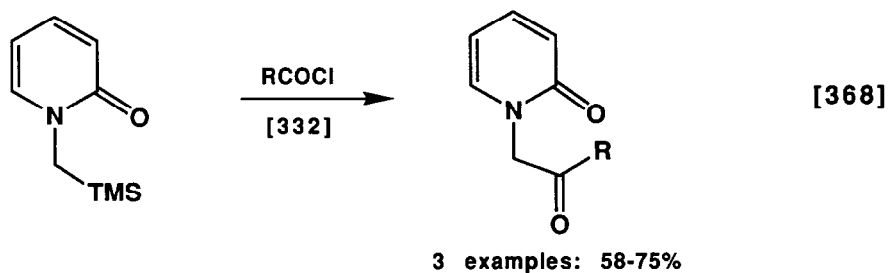
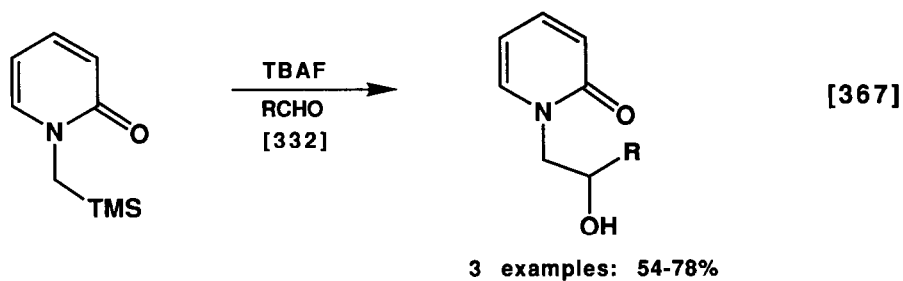

α -Halosilanes were reacted with fluoride ion in the presence of aldehydes to give epoxides as the final product. (Eqn. 369) Cyclopropanes are formed with enones. (Eqn. 370) In the absence of an electrophile the products of carbene intermediates are observed. (Eqn. 371)

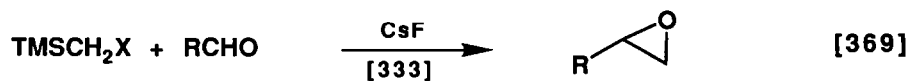

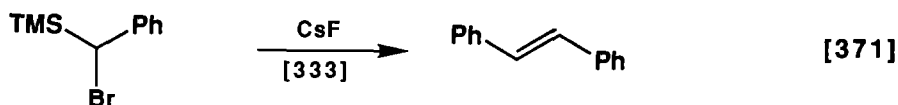
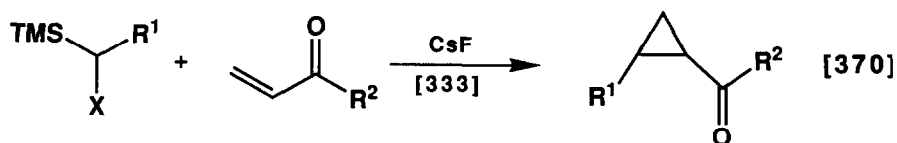

Reaction of **189** with fluoride ion and aldehydes or ketones gives addition followed by cyclization. (Eqns. 372 and 373)

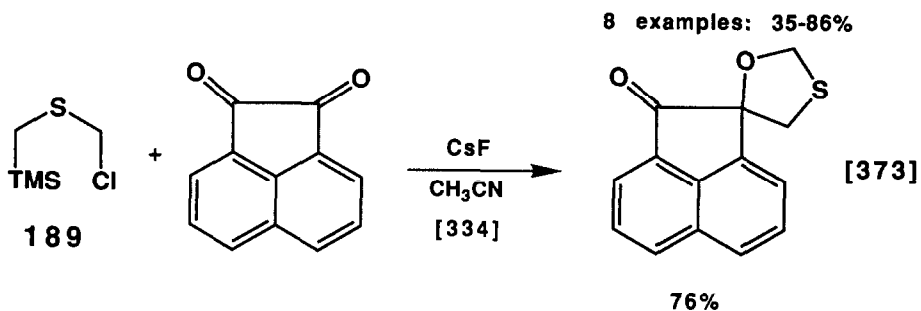
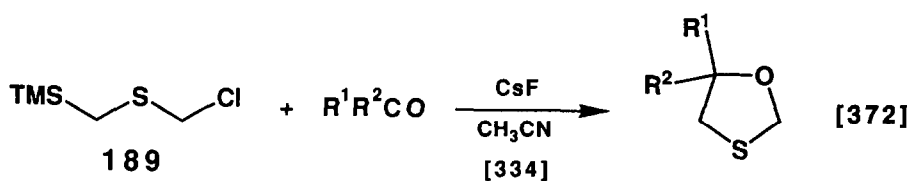

α,α -Dichlorobenzyltrimethylsilane was shown to be a source of phenylchlorocarbene when treated with fluoride ion. (Eqns. 374 -376)

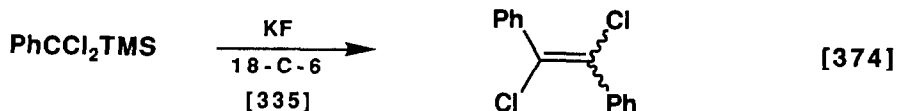

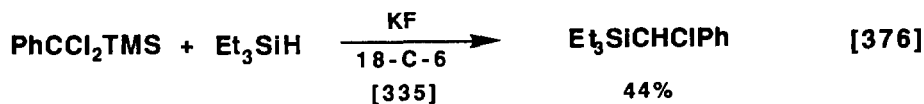
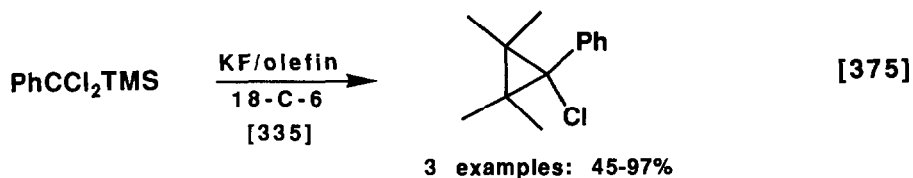

Examples of the use of silicon precursors to 'in situ' generated azomethine ylides were reported. Evidence was provided for the ambivalent behavior of such generated azomethine ylides *via* deuteration experiments. [336] Trisubstituted pyrroles were prepared from **190**, fluoride ion and an electron deficient olefin. (Eqn. 377) Trifluoroacetic acid can be used instead of fluoride ion. This provides the opposite regiochemistry in the reaction. (Eqn. 378)

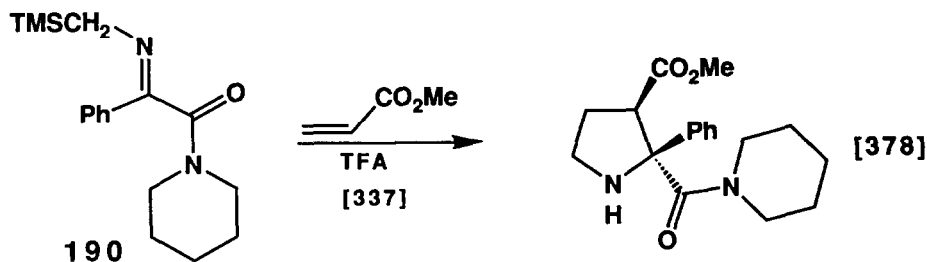
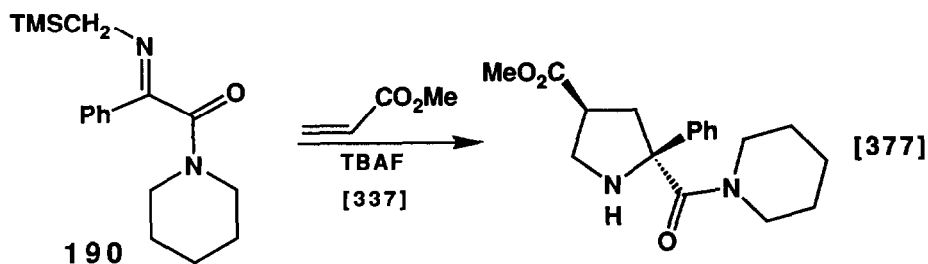

Transient indolium ylides were prepared from **191** and fluoride ion. (Eqn. 379)

Reaction of **192** with cesium fluoride gives **193**, which is considered the unstable intermediate in the Sommelet-Hauser rearrangement of ammonium ylides. (Eqn. 380)

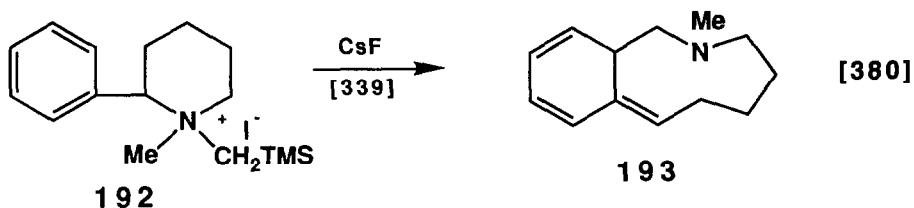
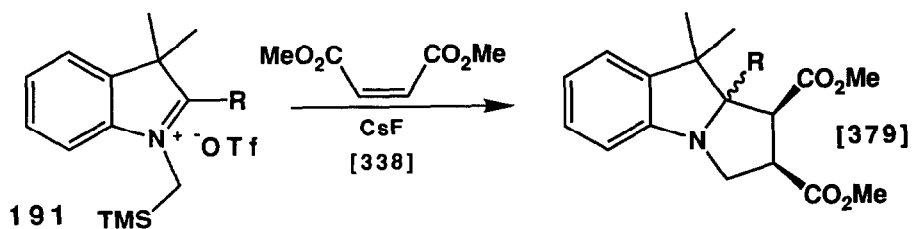

Thiocarbonyl ylides were generated from trimethylsilylmethyl triflate and thio ketones. (Eqns. 381 and 382) They were also thermally produced from **194**. (Eqns. 383 and 384)

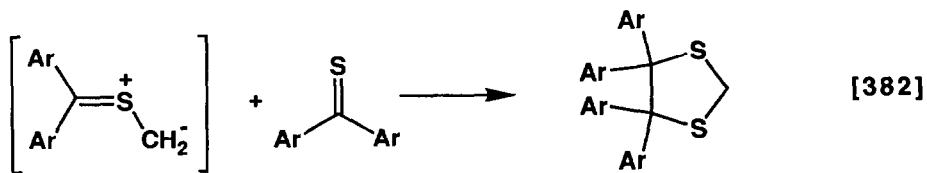
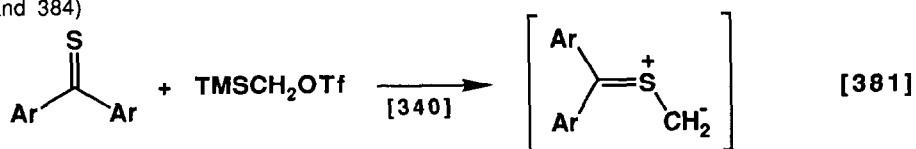

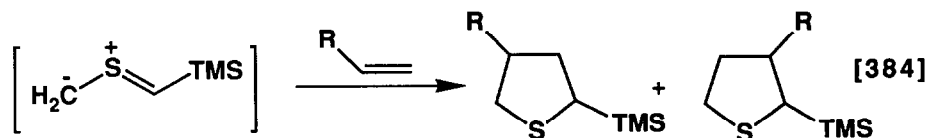
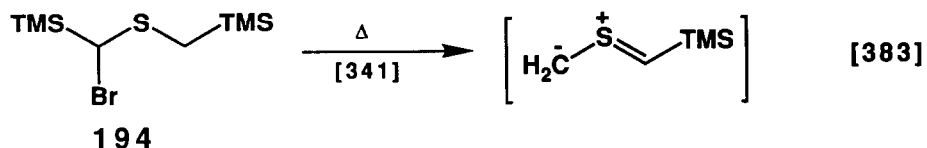

Halomethylsilanes containing an Si-H bond undergo rearrangement when treated with palladium on alumina. (Eqn. 385)

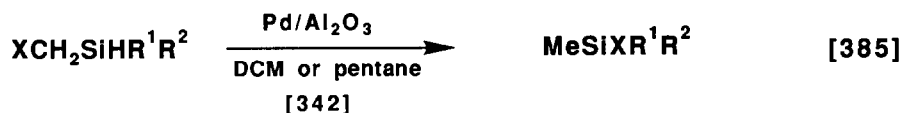

3-Tert-butyldimethylsilylpropargyl alcohols undergo a Brook rearrangement to form a siloxyallenyl lithium reagent. This lithium reagent was reacted with several electrophiles. (Eqn. 386)

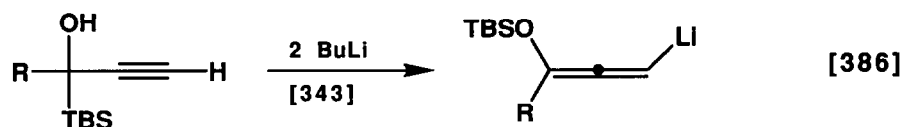

Trimethylsilylmethyl sulfonyl chloride **195** gives **196** upon treatment with triethylamine. (Eqn. 387) This interesting material gives trans-1,2-bis(trimethylsilyl)-thiirane upon photolysis. (Eqn. 388) The reduction of **197** also gives the disilyl thiirane. (Eqn. 389)

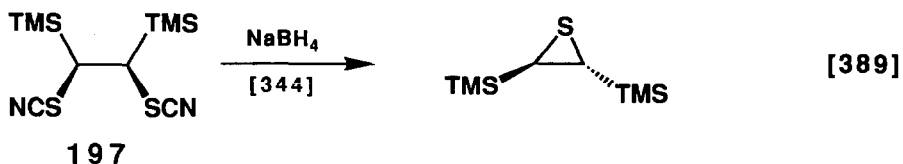
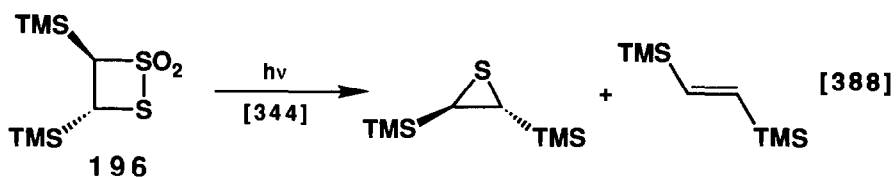
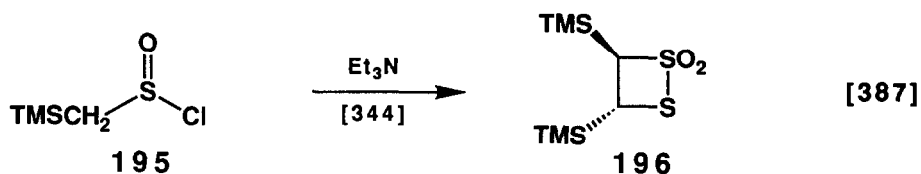

C. α -METALATED ORGANOSILANES

Trimethylsilylmethyl anion was generated in the gas phase and its proton affinity was determined to be -390.9 (± 1.5) kcal/mol. This and other data indicate an α -silyl stabilization of a carbanion of about 20 kcal/mol. [349]

Trimethylsilylmethylmagnesium chloride was coupled with enol phosphonate **198** under the influence of $\text{Ni}(\text{acac})_2$ to provide allylsilane **199**, which was used in the synthesis of racemic heptelidic acid. (Eqns. 390 and 391)

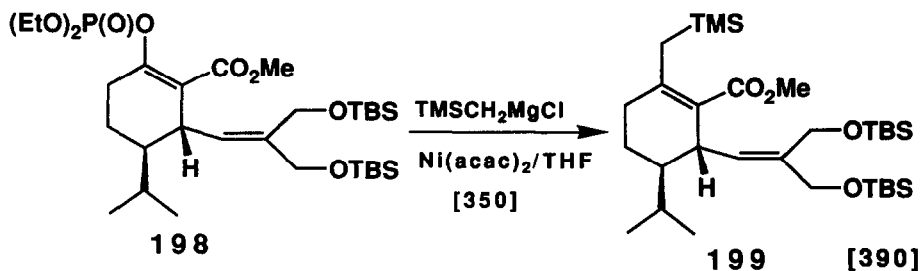

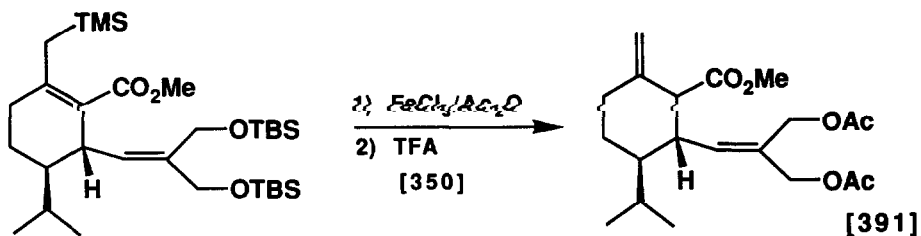

Deprotonation-*tert*-methylsilylation of **200** gives the *Z*-*tert*-methylsilyl derivative, which when subjected to double deprotonation gives the silylmethyl lithium reagent, undoubtedly due to activation by the neighboring carbamate group. (Eqns. 392 and 393)

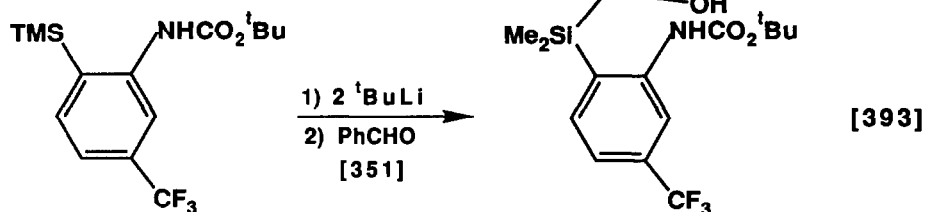
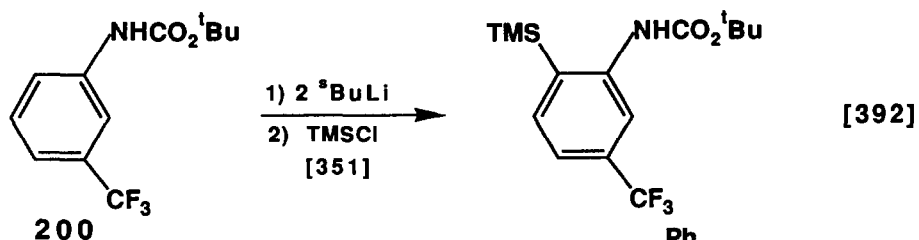

Trimethylsilylmethylbutyl tellurium was subjected to metal-metal exchange to give trimethylsilylmethyl lithium. (Eqn. 394)



Alkylidene and allylidene cyclopropanes were prepared from α -thiophenoxytrimethylsilylcyclopropanes. (Eqns. 395 and 396)

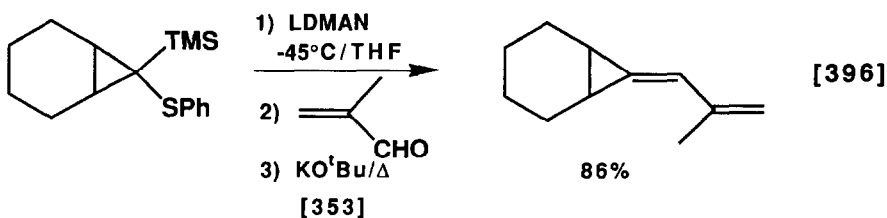
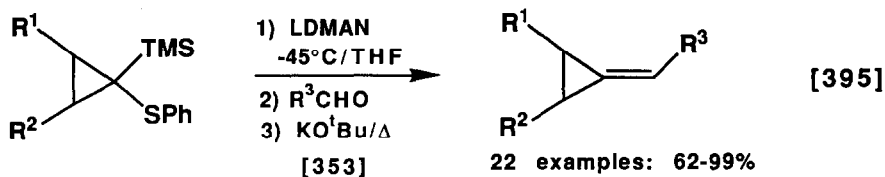

LDMAN = lithium dimethylaminonaphthalenide

The reaction of **201** with tris(trimethylsilyl)methyl chloride results in the formation of tris(trimethylsilyl)methylmagnesium chloride. (Eqn. 397) The reaction of **201** with α -chlorobenzyltrimethylsilane gives α -trimethylsilylbenzylmagnesium chloride. (Eqn. 398)

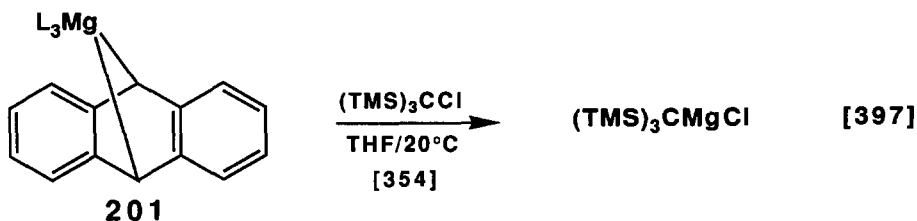

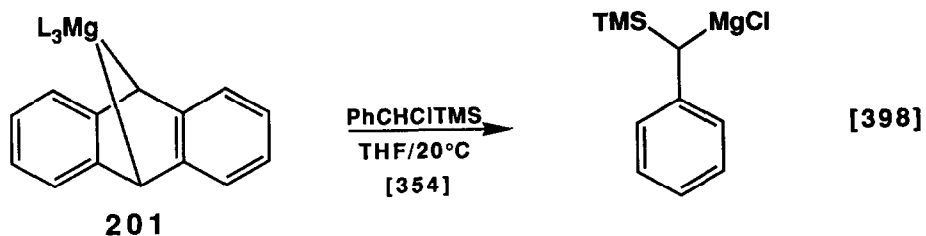

The reaction of trimethylsilylmethylmagnesium chloride with nitrobenzenes gives the ortho-trimethylsilylmethyl derivative. (Eqn. 399) This methodology was the key part of a synthesis of N-methyl indoles. (Eqns. 400 and 401)

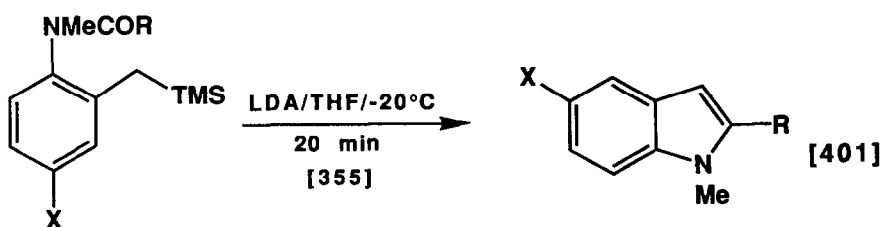
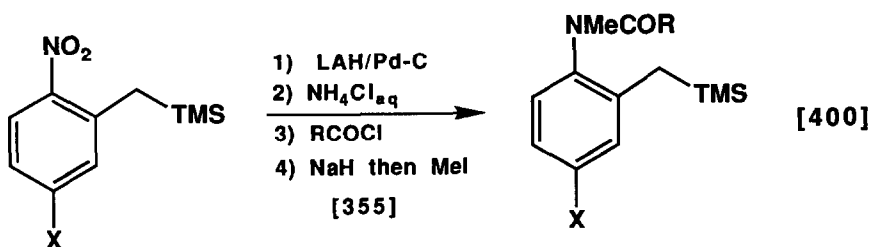
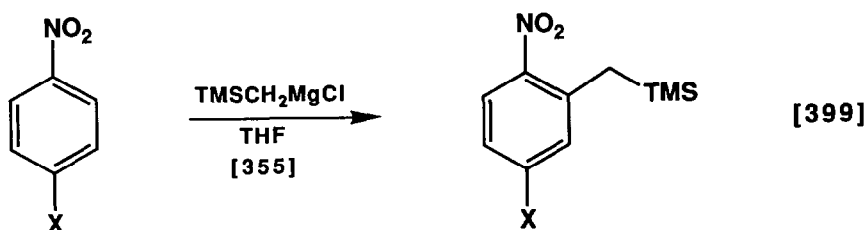

The reaction of (phenyldimethylsilyl)chloromethyl lithium with trialkylalanes (or diisobutylchloroalane) results in a migration of an alkyl group from aluminum to silicon with loss of the chlorine atom from silicon. (Eqn. 402)

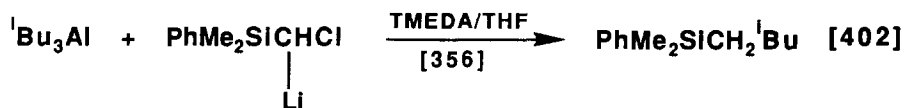

Allylsilanes were deprotonated and then reacted with selenocyanogen to give the γ -cyanoselenide. (Eqn. 403) In a like manner tert-butyldimethylsilylmethyl phenyl sulfone and tert-butyldimethylsilylmethyl dimethylphosphonate were deprotonated and cyanoselenated. (Eqns. 404 and 405)

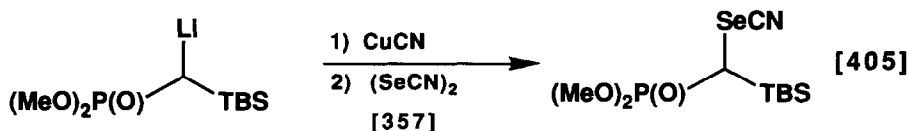
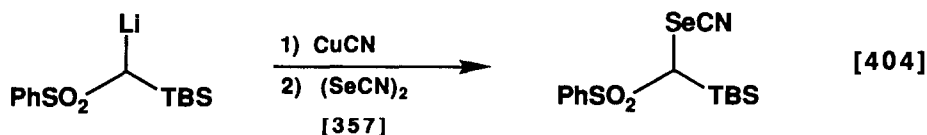
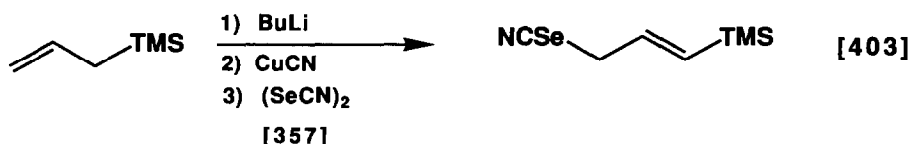

The lithium reagent of bis(thiophenoxy)methyltrimethylsilane was reacted with enones to give α -thiophenoxytrimethylsilylcyclopropanes upon treatment of the intermediate lithium enolate with copper(I) triflate. (Eqns. 406 and 407)

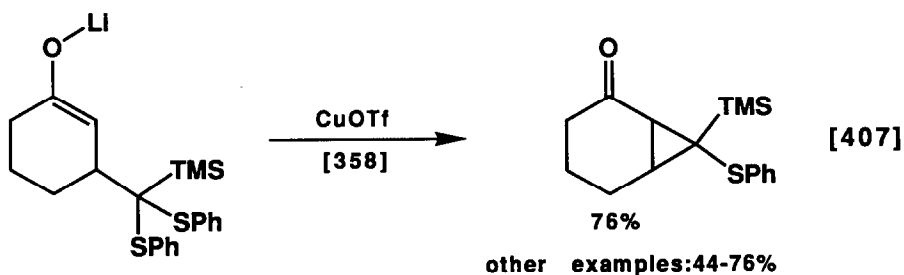
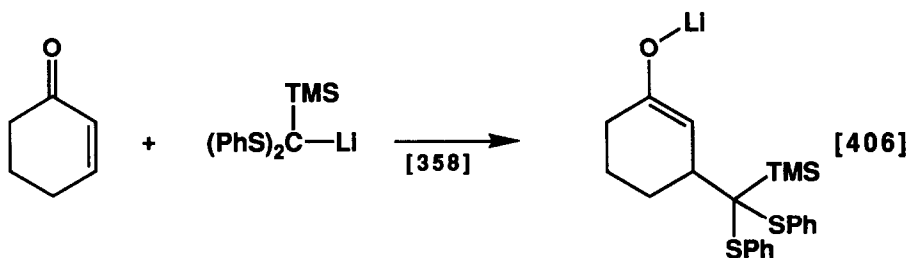

In a similar procedure lithium reagent **202** was reacted with enones and the intermediate enolate ion alkylated. (Eqn. 408) The α -functionalized organosilyl group could be converted to an acylsilane (Eqn. 409) or desilylated (Eqn. 410). This methodology formed part of a synthesis of sarkomycin.

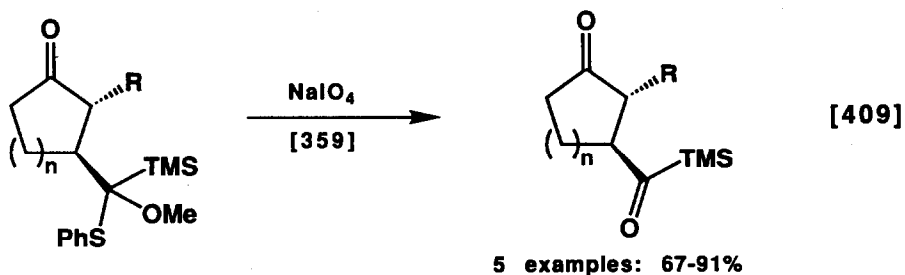
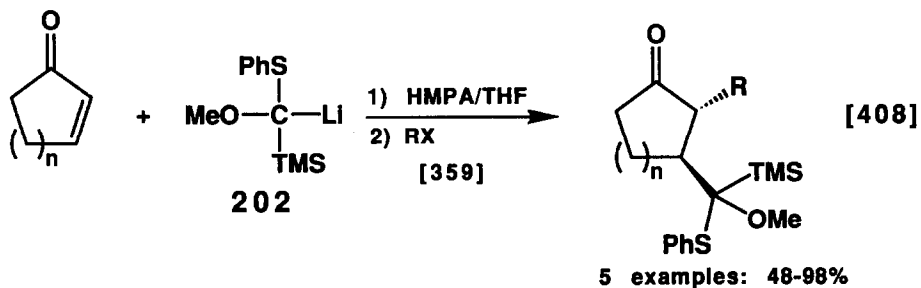

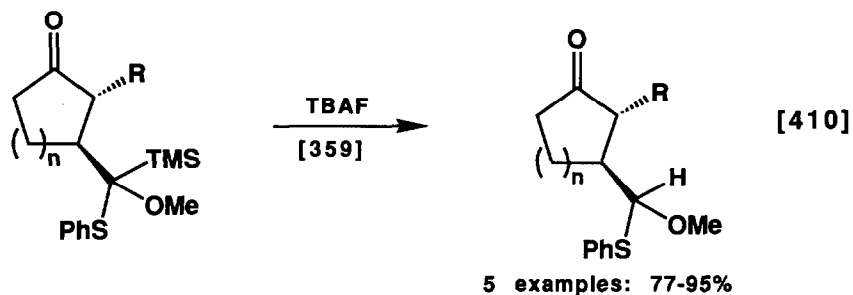

Trimethylsilylmethanol was deprotonated and reacted with carbon dioxide, deprotonation of this product gives the α -lithiosilane. (Eqn. 411) This was reacted with acid chlorides (Eqn. 412), amides (Eqn. 413), nitriles (Eqn. 414), and esters (Eqn. 415) to give hydroxymethylation in all cases.

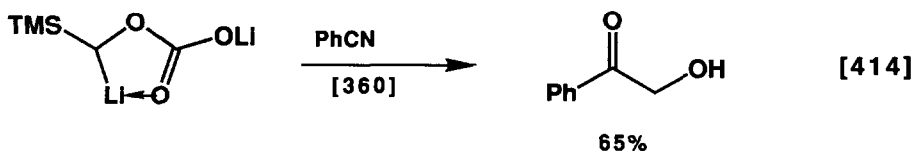
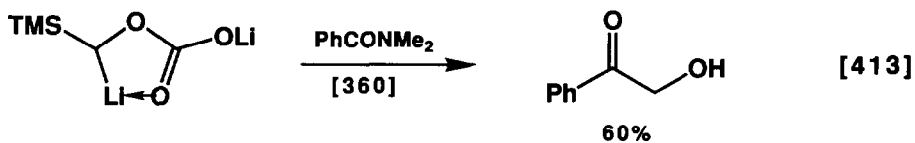
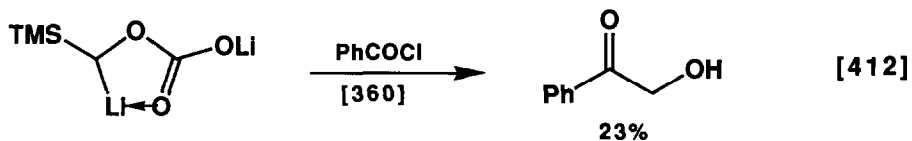
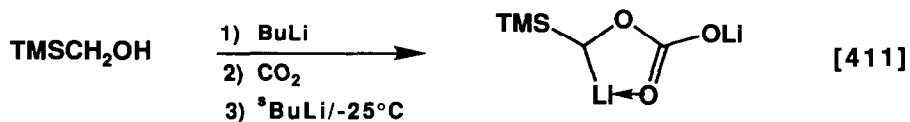

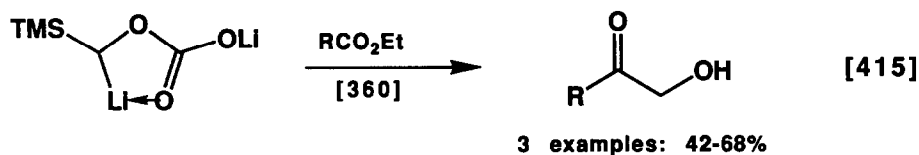

The lithium reagent of trimethylsilyldiazomethane was reacted with thio benzophenone to give vinylsilanes. (Eqn. 416) On the other hand it reacted with di-tert-butylthio ketone to give the cycloadduct. (Eqn. 417)

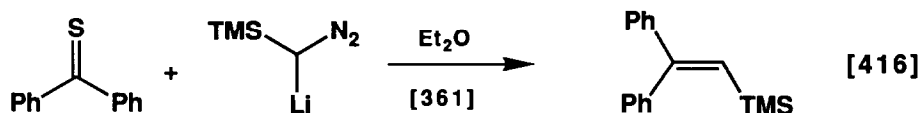

$\text{Ph}-\text{C}\equiv\text{C}-\text{Ph}$ is obtained in THF solvent

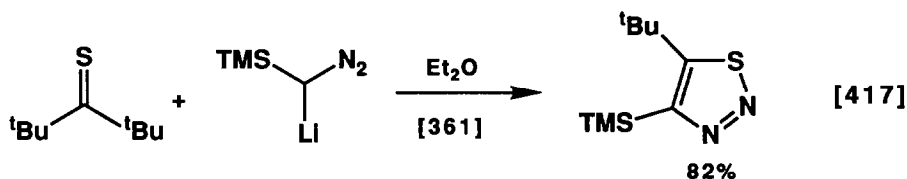

The lithium reagents of α -silyl esters continued to be useful, especially in synthetic endeavors. It was found that phosphonate esters could be treated with two equivalents of lithium diisopropylamide (LDA) and then a single equivalent of a trialkylchlorosilane to give the α -silyl lithium reagent directly in a single step. (Eqn. 418) The lithium reagents, thusly generated, were protonated and alkylated and reacted with acetaldehyde. (Eqns. 419 and 420) It was further found that treatment of the phosphonate ester with 3 equivalents of LDA and then 2 equivalents of trimethylchlorosilane results in the α,α -bis(trimethylsilyl)lithium reagent. (Eqn. 421)



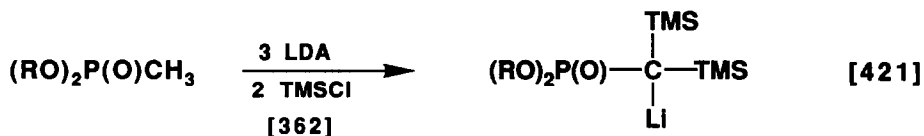
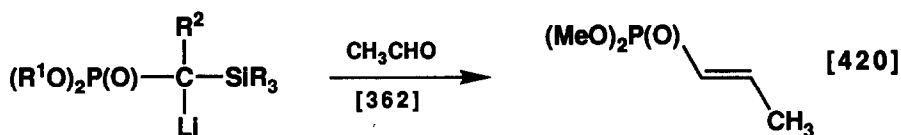
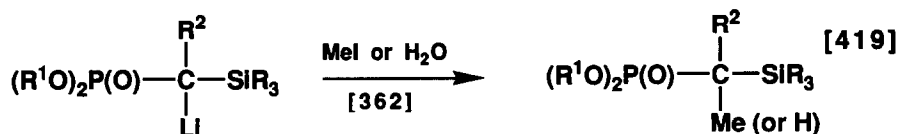

The reaction of ethyl bromo(trimethylsilyl)acetate with zinc/silver couple in the presence of an aldehyde or ketone gives Reformatsky products. (Eqn. 422)

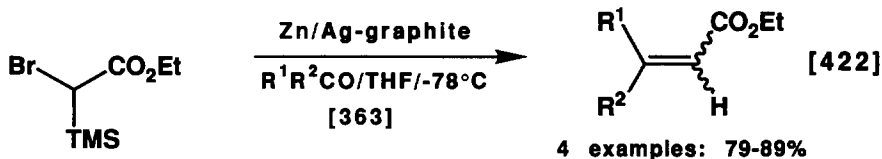

Ethyl [(trimethylgermyl)trimethylsilyl]acetate was lithiated and reacted with aldehydes to give the β -trimethylgermyl- α,β -unsaturated esters as a result of loss of the trimethylsilyl group rather than the trimethylgermyl group. (Eqn. 423) Treatment of the parent ester with fluoride ion results in protodesilylation. (424)

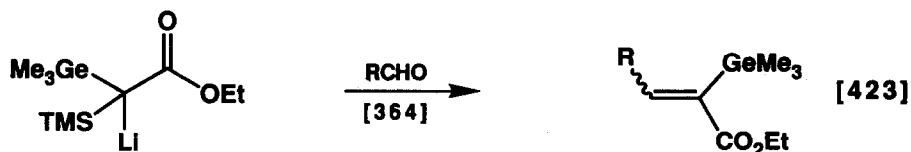

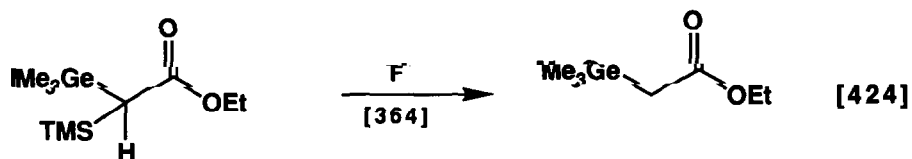

The reaction of ethyl lithio(trimethylsilyl)propionate with ketone **203** was used in an asymmetric synthesis (Eqn. 425)

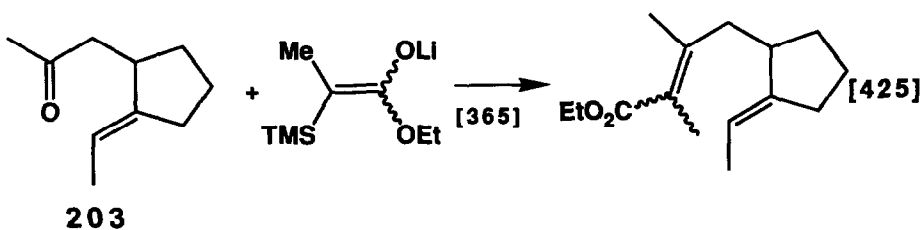

Ethyl lithio(trimethylsilyl)acetate was used as a key step in the preparation of vallesiachotamine. (Eqns. 426 and 427)

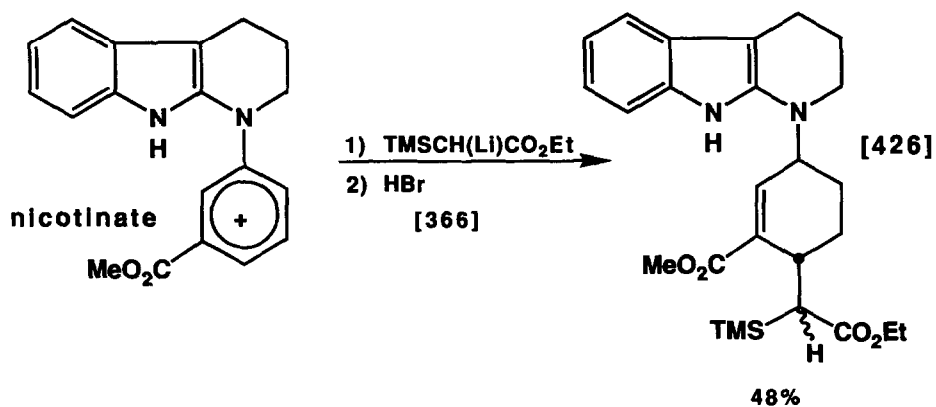

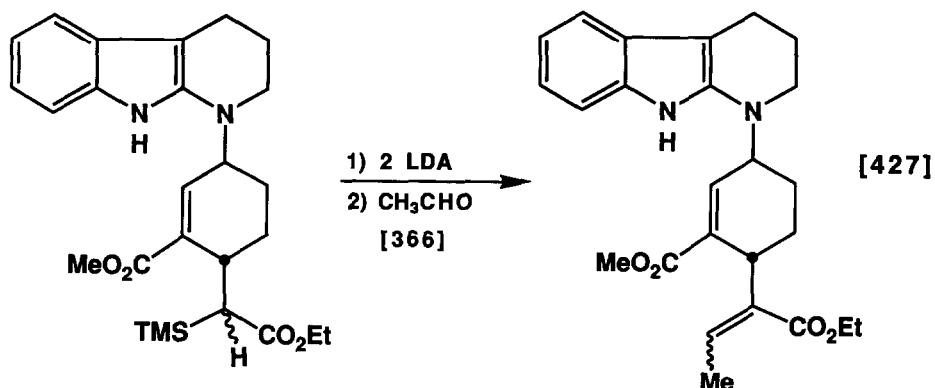

D. Other Studies

The x-ray crystal structure of **204** showed it to be a strongly perturbed trigonal bipyramidal structure. [345] The crystal structure of **205** was reported. It shows strong interaction of the lithium atoms with the oxygens of the sulfone group. [346] The trimethylsilylbis(thiomethoxy)methyl group of **206** directed the mode of alkylation to provide the cis product contrary to all other groups looked at in this reaction. [347] The effect of fluorination on the Si-C bond length was investigated. [348]

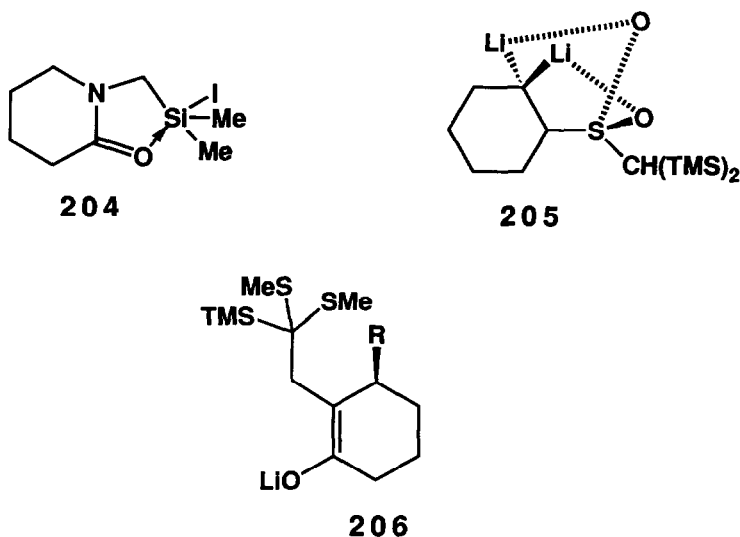

XIII. β -FUNCTIONAL ORGANOSILANES

A. Preparation

α -Silylisoxazoles were prepared by reaction of the lithio isoxazole with a chlorosilane. (Eqn. 428)

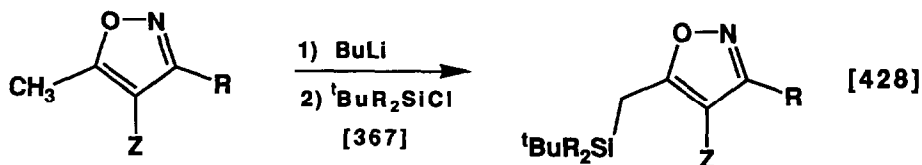

Deprotonation-trimethylsilylation of cyclopropanone hydrazones gives the α -trimethylsilyl cyclopropanone hydrazones. (Eqn. 429) Double deprotonation-trimethylsilylation of cyclopropanone hydrazones gives the α,α -bis(trimethylsilyl) cyclopropanone hydrazones. (Eqn. 430)

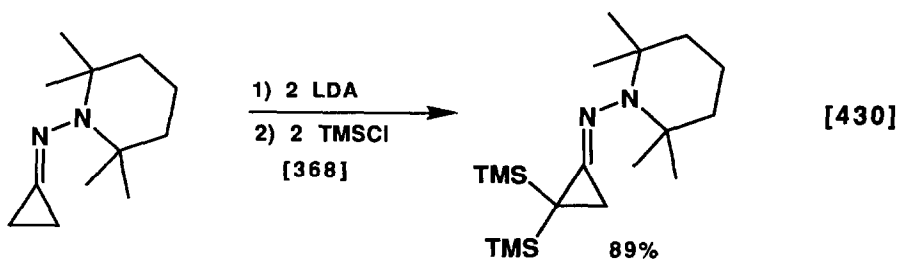
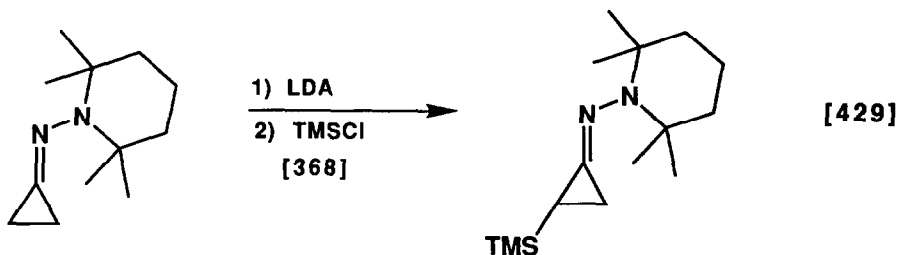

The reaction of thiophenoxytrimethylsilane with ketene gives the α -trimethylsilyl thioacetate. (Eqn. 431)

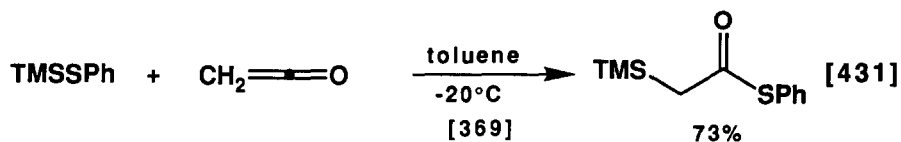

The reaction of trimethylsilyldiazomethane with aldehydes in the presence of magnesium bromide leads to trimethylsilylmethyl ketones in an interesting reaction since it is known that Lewis acids bring about the rearrangement of α -silyl ketones to their enol silyl ethers. (Eqn. 432) Protodesilylation gives the corresponding methyl ketone. (Eqn. 433)

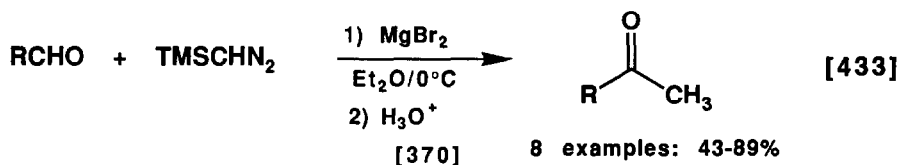
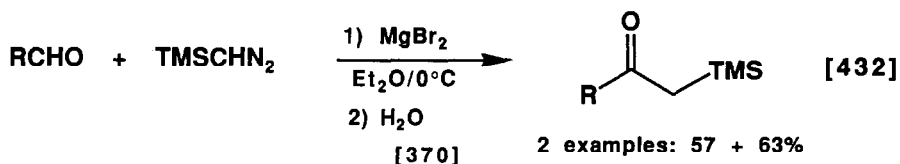

Peracid oxidation of silyl ketone **207** gives the silyl-directed Bayer-Villiger reaction and β -carboxysilane **208**. (Eqn. 434) Treatment of **208** with base and then boron fluoride etherate gives the unsaturated acid **209**. (Eqn. 435)

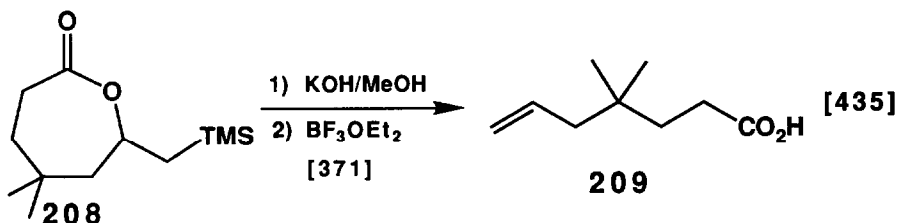
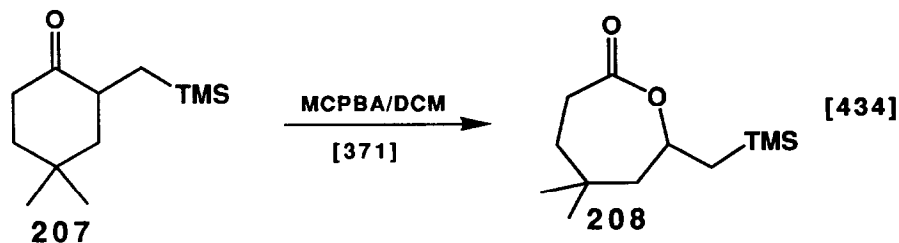

β,β -Dibromotrimethylsilylcyclopropanes were reduced to the monobromo derivatives with diethyl phosphite. (Eqn. 436)

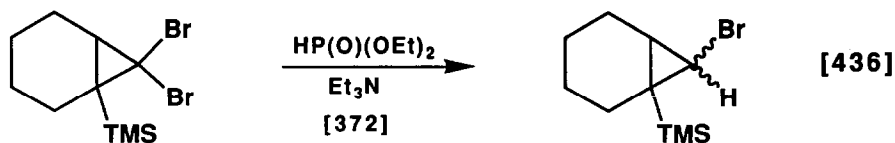

B. Reactions

β -Mercaptoethyltrimethylsilane was reacted with carboxylic acids to give β -trimethylsilyl thio esters. These were treated with fluoride ion in the presence of an alkylating agent to give the the alkylated thio ester. (Eqns. 437 and 438) β -Trimethylsilylethyl sulfides when treated with dimethyldisulfide and boron fluoride etherate give alkyl methyl disulfides. (Eqn. 439)

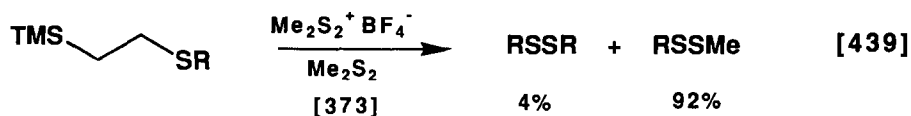
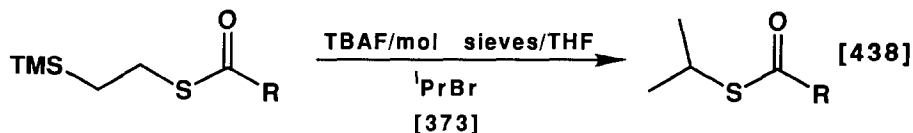
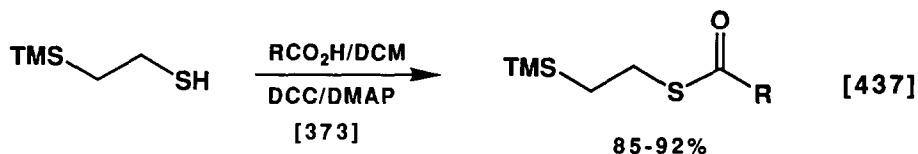

β -Mercaptoethyltrimethylsilane was reacted with bromochloromethane and then triphenylphosphine to give the phosphonium salt, which was employed in Wittig reactions with aldehydes and ketones. (Eqns. 440 and 441) Oxidation of the product of the Wittig reaction provides a mixture of the sulfoxide and the sulfone. (Eqn. 442) Treatment of the sulfone with fluoride ion in the presence of methyl iodide gives the methyl sulfone. (Eqn. 443)

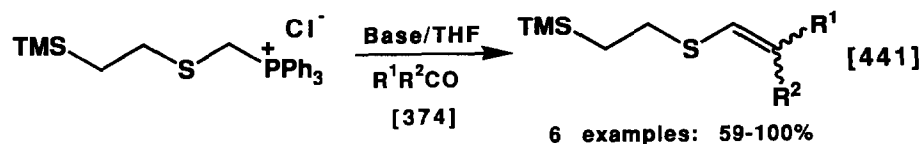
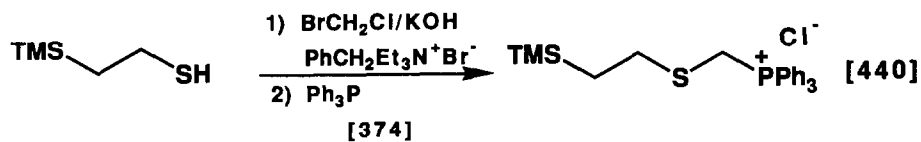

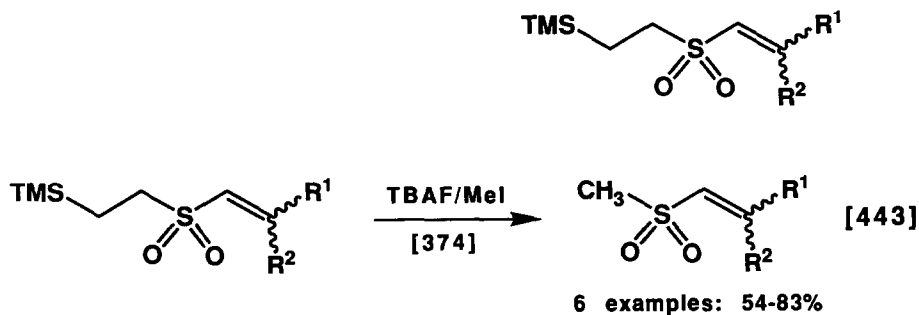
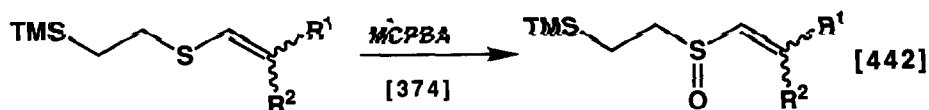

Trimethylsilylethyl phenyl sulfone can be alkylated once (Eqn. 444) or twice (Eqn. 445). These materials are precursor to mono- or disubstituted alkenes when treated with fluoride ion. (Eqns. 446 and 447) Deprotonation and then reaction with an aldehyde or ketone gives β -sulfonyl alcohols. (Eqn. 448) These when mesylated and reduced give allylsilanes in excellent yields. (Eqn. 449) Cyclopropanes are possible when the anion is treated with epoxides and the resulting γ -hydroxy sulfone suitably reduced. (Eqn. 450) Reduction of the anion with aldehydes or ketones by subsequent reaction reduction gives γ -ketosilanes. (Eqn. 451) Chloromethylation of a trimethylsilyloxy-ethyl sulfone and then treatment with fluoride ion gives α -alkyl vinylsulfones. (Eqn. 452) The α -chlorosulfone itself can be deprotonated and reacted with aldehydes or ketones followed by fluoride ion to give α -sulfonyl allyl alcohols. (Eqn. 453)

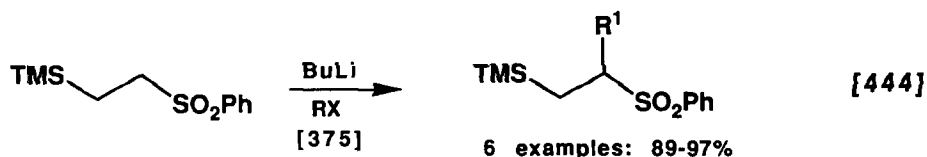

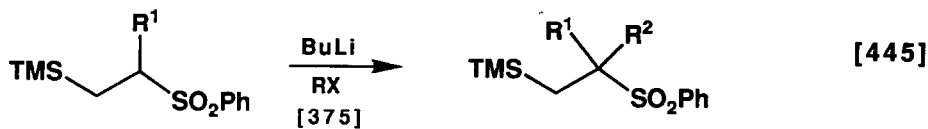

3 examples: 90-91%



3 examples: 84-92%



3 examples: 76-83%

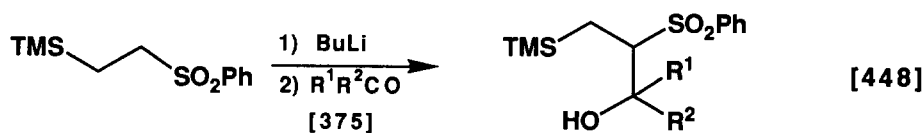

4 examples: 92-95%

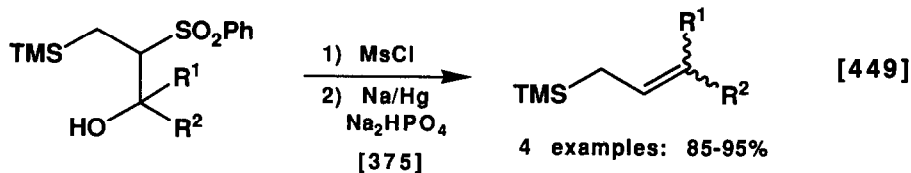

4 examples: 85-95%

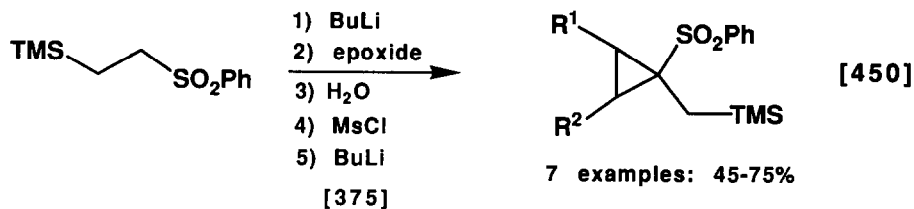

7 examples: 45-75%

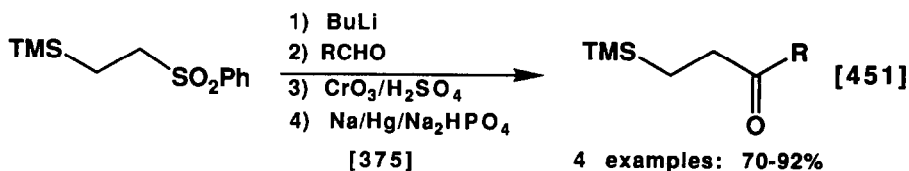

4 examples: 70-92%

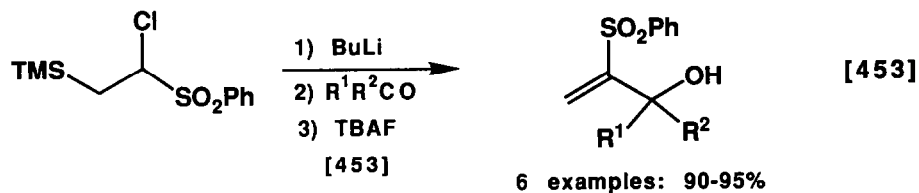
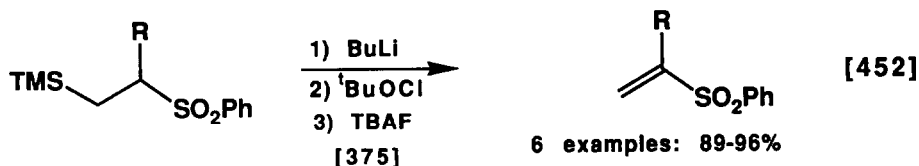

Various catalysts were found to bring about the rearrangement of α -trimethylsilyl- α' -chloro ketones to the enol silyl ethers. (Eqn. 454)

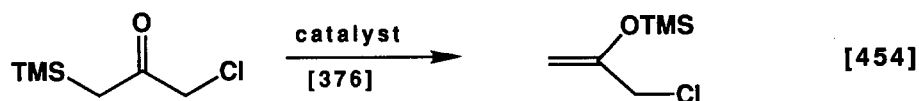

Catalysts = $[\text{IrH}(\text{CO})(\text{PPh}_3)_3]$, $\text{trans}-[\text{IrCl}(\text{CO})(\text{PPh}_3)_2]$, $[\text{Pd}(\text{PPh}_3)_4]$, $[(\text{trans-stilbene})(\text{PPh}_3)_2]$ and $[\text{Pt}(\eta^3\text{-CH}_2\text{COCH}_2)(\text{PPh}_3)_2]$

Ethyl or methyl trimethylsilylacetate were shown to thermally eliminate trimethylsilyl methoxide (or ethoxide) and give ketene in a first order process. (Eqn. 455)

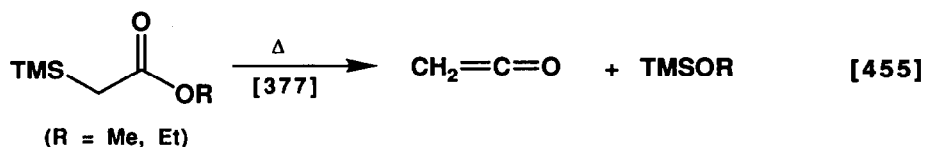

1-Trimethylsilylcyclopropyl carboxy esters were reacted with fluoride ion in the presence of aldehydes and ketones. (Eqn. 456) A similar reaction was carried out with

1-trimethylsilylcyclopropyl nitriles. (Eqn. 457) 1-Trimethylsilylcyclopropyl methyl ketones give products derived from the enolate towards the methyl side of the ketone.

(Eqn. 458) On the other hand the vinylogous enones give the desired reaction. (Eqn. 459)

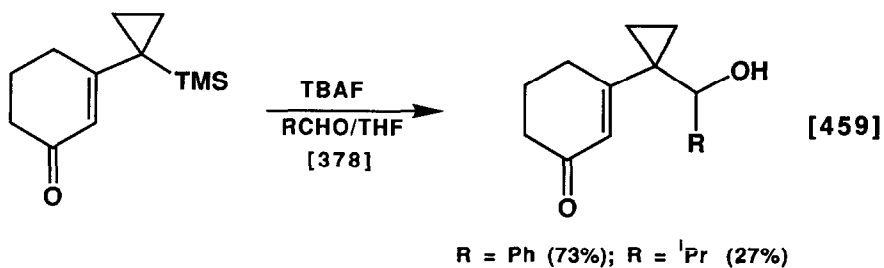
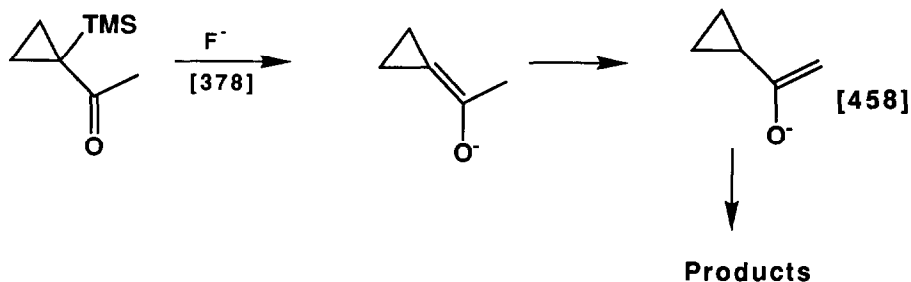
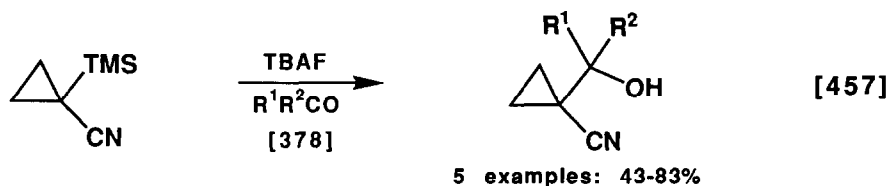
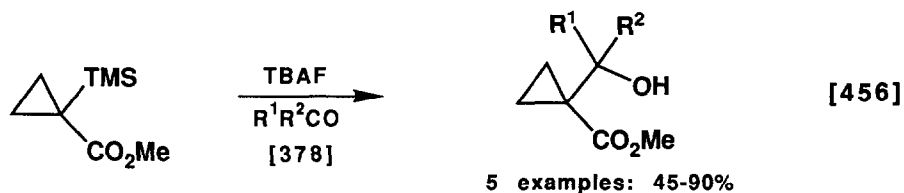

Trimethylsilylcyclopropanones were shown to react with N-trimethylsilyl

lactams to give the substituted cyclopropanols as their trimethylsilyl ethers. (Eqn. 460)

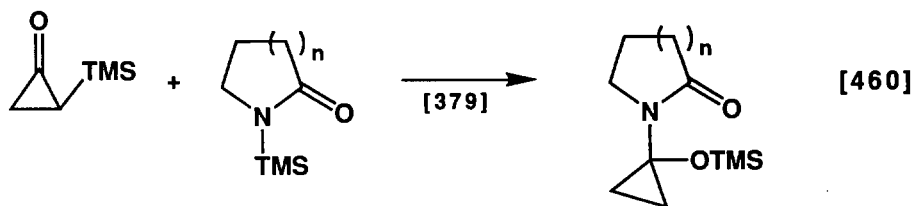

2,3-Bis(silyl)cyclopropanones thermally or photochemically lose carbon monoxide to form 1,2-bis(silyl)ethylenes. A similar reaction was observed for the sulfone **210**. (Eqn. 462)

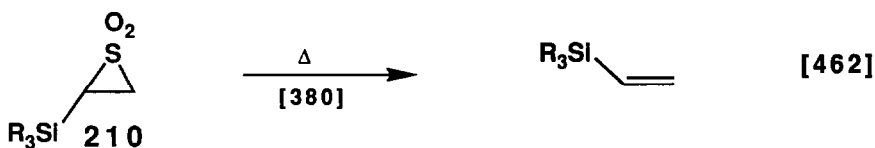
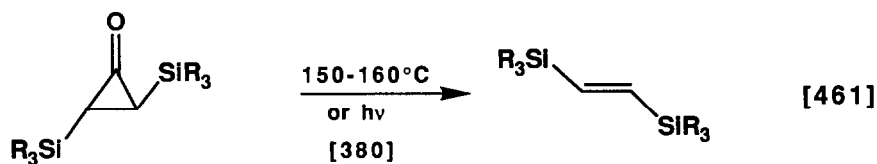

1,3,5-Trinitrobenzene was shown to react with various active organosilanes under the influence of fluoride ion. (Eqn. 463) Oxidation of the initial product gives the overall addition to the aromatic. (Eqn. 464) The R group in Eqn. 463 can be allyl, benzyl, an ethynyl, a β -keto system or a β -ester group. Enol silyl ethers also react in this system.

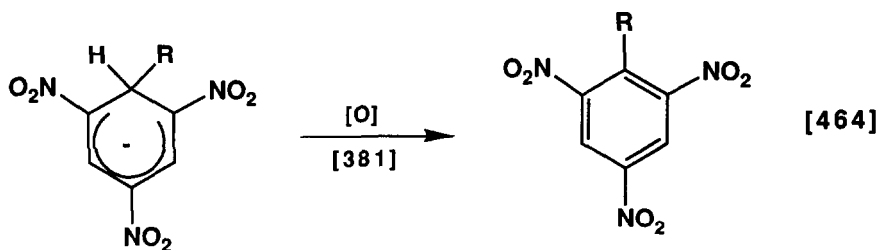
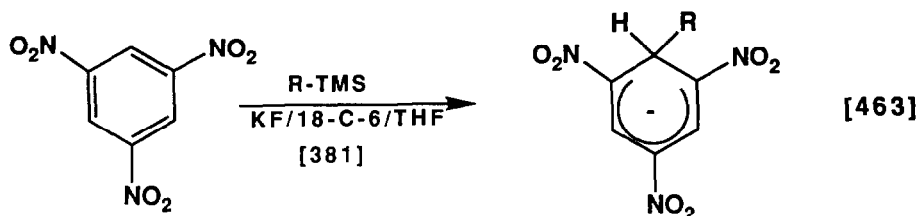

β -Hydroxysilanes were oxidized with concomitant loss of the silyl group to an ester (Eqn. 465) and an aldehyde (Eqn. 466).

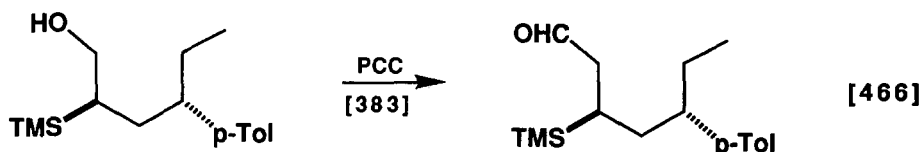
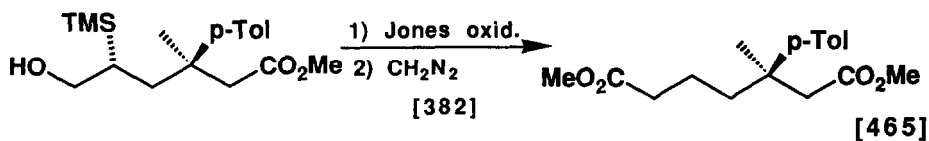

The silyl-containing Wittig reagent **211** was shown to react with epoxy aldehydes to give erythro/threo mixtures of functionalized epoxides **212**. (Eqn. 467)

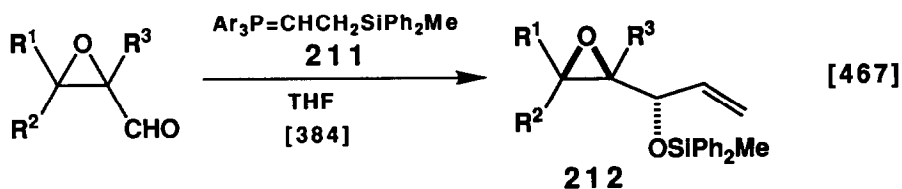

Treatment of **213** with magnesium metal gives rearrangement to **214**. All attempts to bring about a Peterson-type elimination failed. Treatment with base, for example, gave the dimer **215**. (Eqns. 468 and 469)

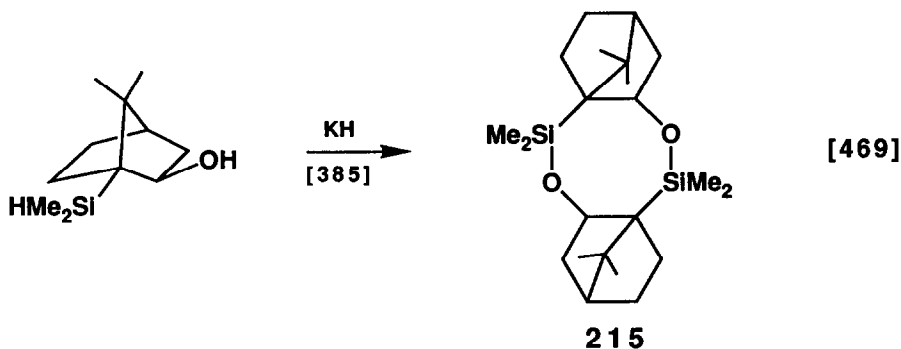
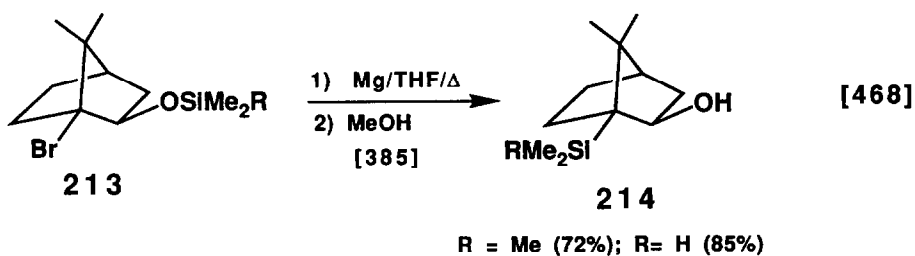

It was shown that the product of addition of trichlorosilane to enamines can be protodesilylated resulting in overall reduction of the enamine. (Eqns. 470 and 471)

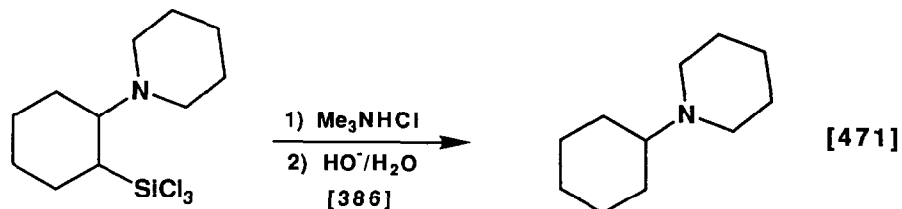
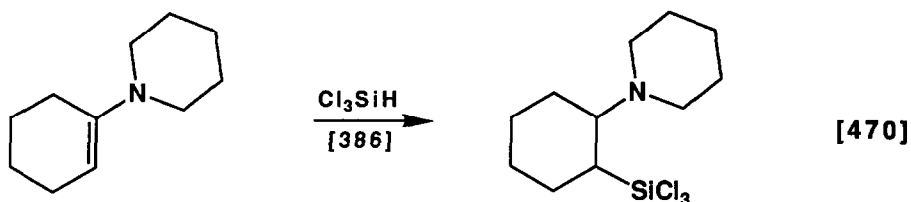

9 examples: 52-74%

Treatment of diepoxide **216** with fluoride ion in the gas phase forms the silicon analog of fluoroformate anion. (Eqn. 472) The monoepoxide **217** gives the adduct of fluoride ion to dimethylsilanone. (Eqn. 473)

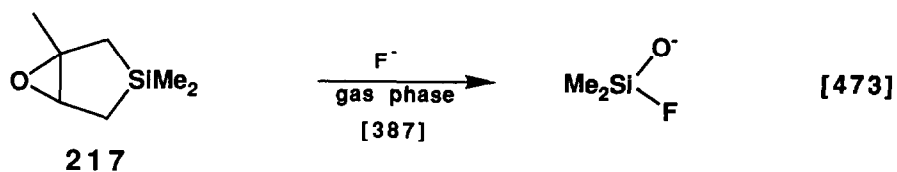
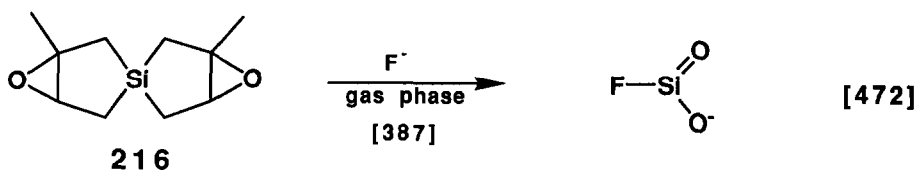

C. Other Studies

The structure of **218** was determined and showed a half-chair conformation with equatorial substituents preferred. [388] The stabilization of a positive charge by a

β -silyl group was investigated *via* kinetic solvolysis studies with systems of the type

219. [389]

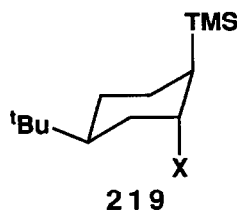
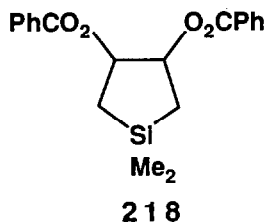

XIV. MISCELLANEOUS FUNCTIONAL ORGANOSILANES

A. γ -FUNCTIONAL ORGANOSILANES

The γ,γ,γ - and $\epsilon,\epsilon,\epsilon$ -trichloroalkylsilanes **220** were reacted with transition metal carbonyls to give the dichloro derivatives. (Eqn. 474) Some chlorination of the alkyl C-H bonds was also observed. The reaction in the presence of triethylsilane as a reducing agent gives 1,1-dichloroalkenes. (Eqn. 475)

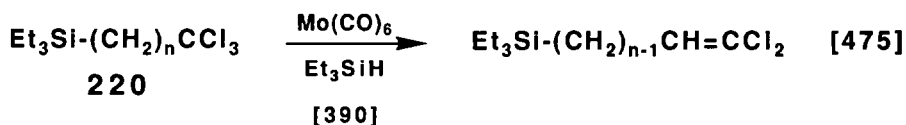
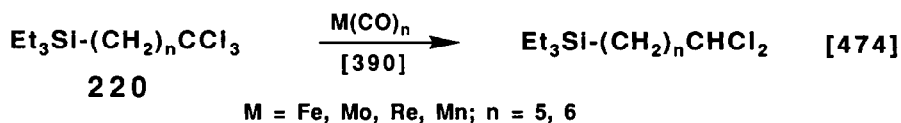

The bis hydroboration-oxidation of diallyldiphenylsilane provides the bis(hydroxypropyl)diphenylsilane. (Eqn. 476) This was converted to the bis(acryloxypropyl)diphenylsilane upon reaction with acryloyl chloride. (Eqn. 477)

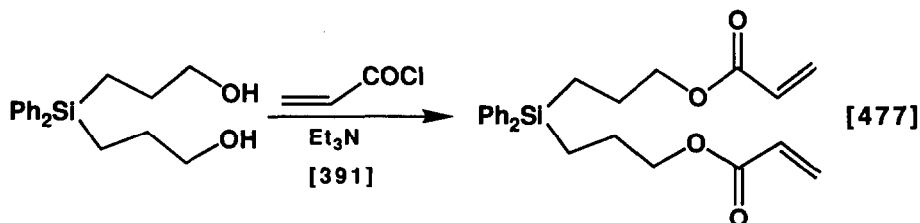
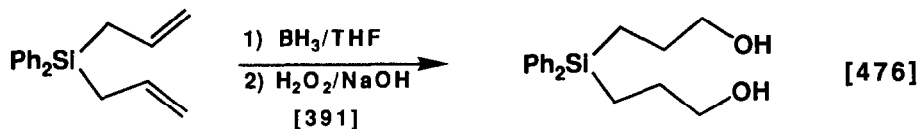

Stepwise deprotonation-trimethylsilylation of **221** gives the γ -amidosilane

222. (Eqn. 478)

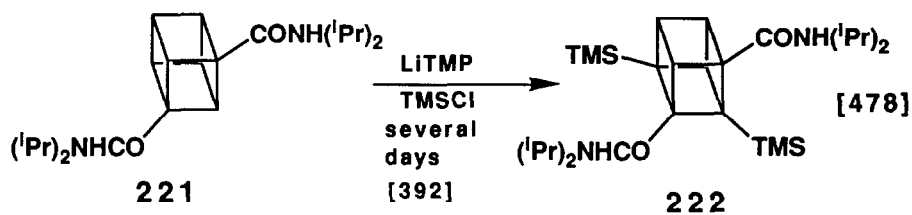

The addition of lithium bis(phenyldimethylsilyl)cyanocuprate to α,β -unsaturated lactones and lactams leads to the γ -silyl lactone or lactam. (Eqns. 479 and 480) The phenyldimethylsilyl group can be stereospecifically oxidized to the alcohol to give the γ -hydroxy derivatives. (Eqns. 481 and 482)

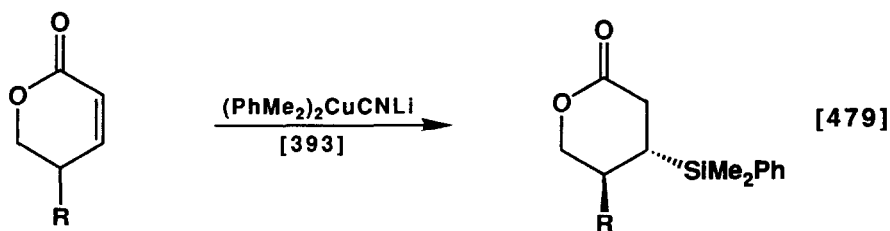

3 examples: 33-94%

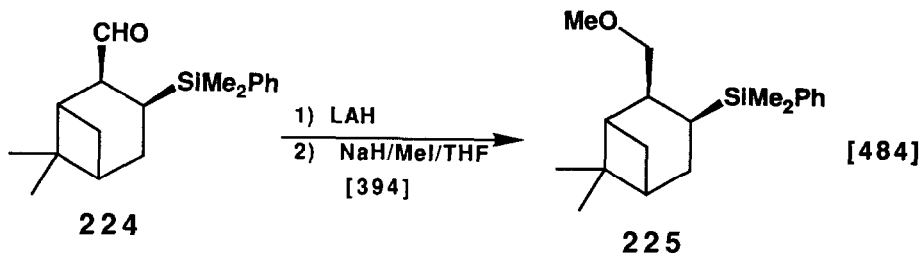

The addition of Grignard reagents to enone **226** gives the *trans*- γ -trimethylsilyl ketones **227** (Eqn. 485), which were oxidatively desilylated to new enones (Eqn. 486).

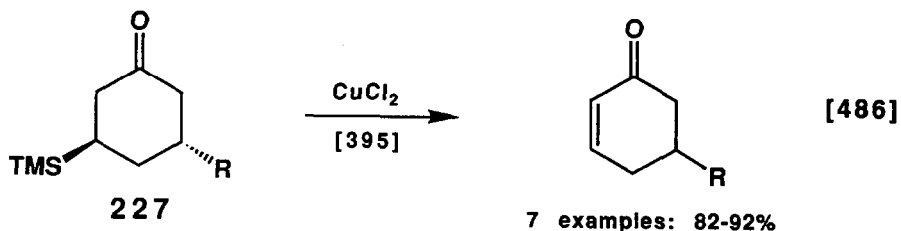
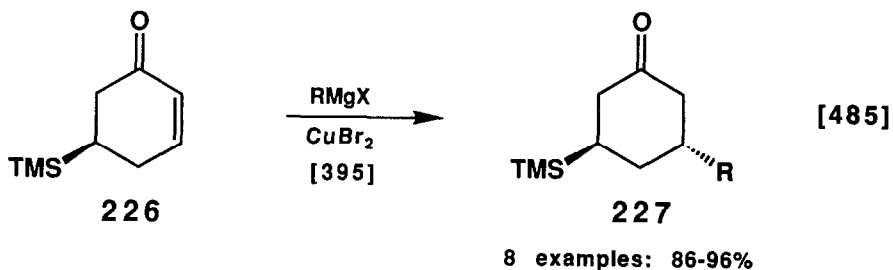

The 1,4-elimination of γ -trimethylsilyl alcohols was accomplished with cerium ammonium nitrate. (Eqn. 487)

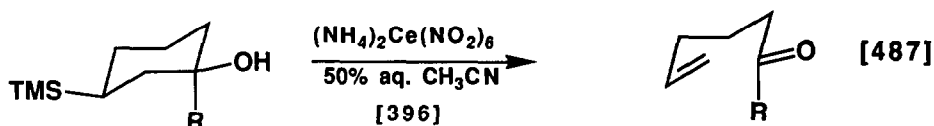

A study of the elimination of the *p*-bromobenzenesulfonate ester of 4-trimethylsilyl-1-butanol is ca. 100 times faster than that of the analogous carbon compound.

(Eqn. 488)

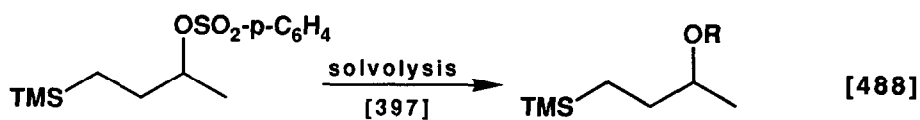

Two systems, which are not γ -functional silanes are also reported here. The δ -mesyl silane **228** and related materials were used to study the effect of the trimethylsilyl group on the rearrangement of carbocations. (Eqn. 489) The results are consistent with a β -stabilization of the carbocation by silicon. Reaction of the Grignard reagent from 2-(2-iodoethyl)-1,3-dioxane with trimethylsilylmethyl chloride gives the δ -functionalized silane. (Eqn. 490)

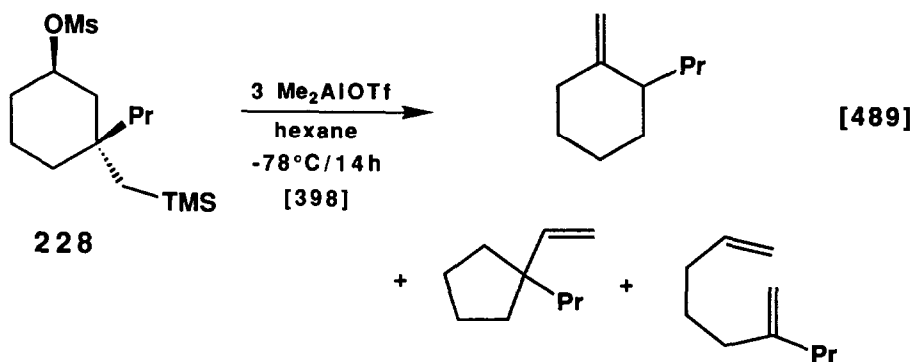

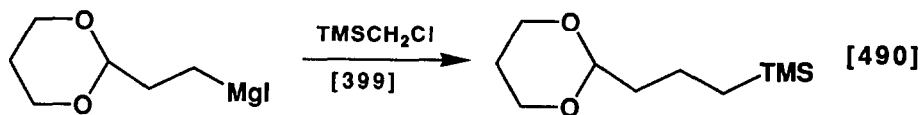

B. Epoxysilanes

Phenylsulfonyl oxirane was shown to be deprotonated with butyllithium. The lithium reagent was trimethylsilylated in quantitative yield. (Eqn. 491)

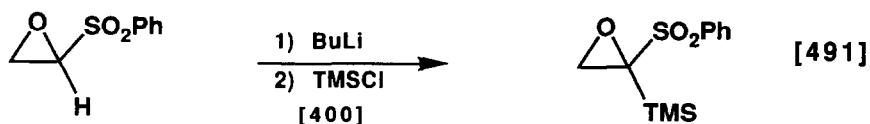

Trimethylsilyl oxirane was reacted with trimethylsilylethynyltriisopropoxytitanium to give ring opening selectively at the silicon bearing carbon. (Eqn. 492)

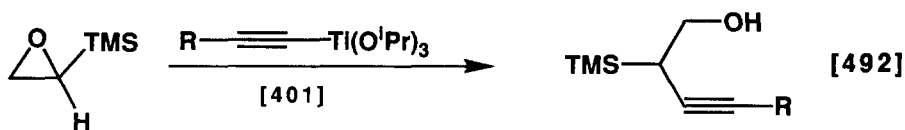

Lithium divinylcuprates were shown to react with epoxysilanes at the silicon bearing carbon resulting in a β -hydroxysilane, which could be syn or anti eliminated to stereoselectively produce 1,3-dienes. (Eqns. 493-495)

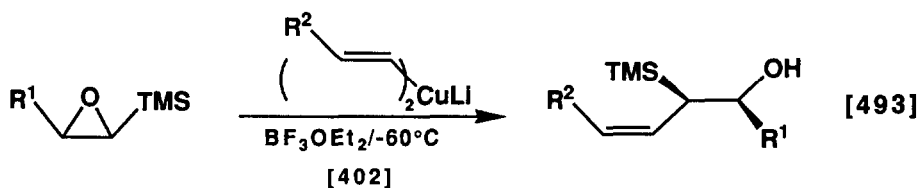

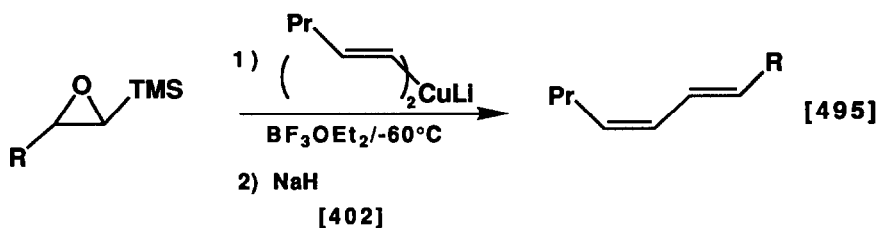
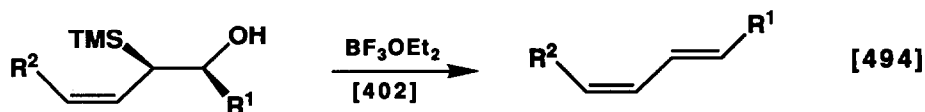

The epoxide **228** was ring opened, again at the silicon-bearing carbon, with tributylstannyl lithium followed by loss of lithium trimethylsiloxide. (Eqn. 496) The epoxysilane **229** was reacted with magnesium bromide and then methanesulfonyl chloride/triethylamine to give vinyl bromide **230**. (Eqn. 497)

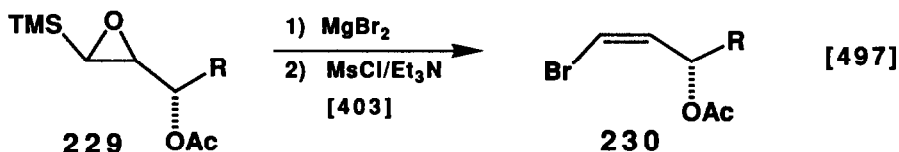
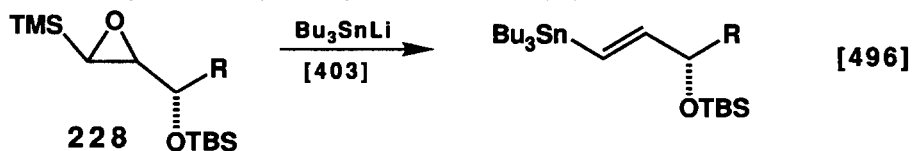

C. Acylsilanes

The Swern oxidation of trimethylsilylmethanol gives formyltrimethylsilane, which can be reacted without isolation with organolithium or organomagnesium reagents to give α -hydroxysilanes. (Eqns. 498 and 499) Oxidation of these α -hydroxysilanes leads to acylsilanes. (Eqn. 500)

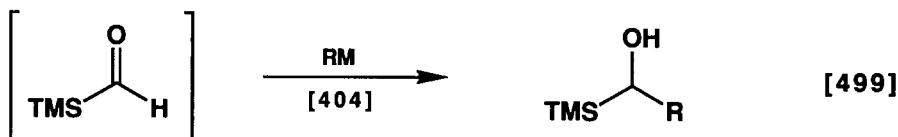
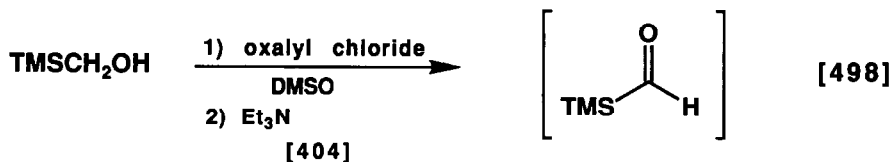

(M = Li, MgX)

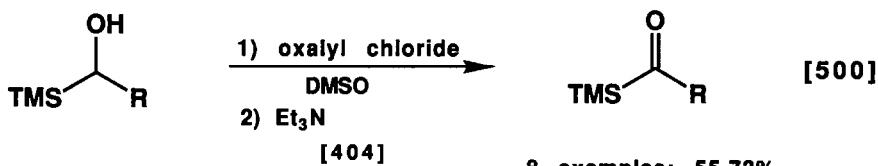

8 examples: 55-73%

Lithium bis(trimethylsilyl)cuprate reacts with acyl chlorides to give acylsilanes. (Eqn. 501) Similarly, lithium (triphenylsilyl)phenylcuprate was reacted with benzoyl chloride to give the acylsilane. (Eqn. 502)

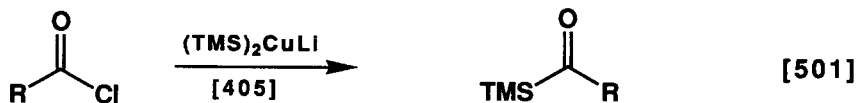

11 examples: 39-87%

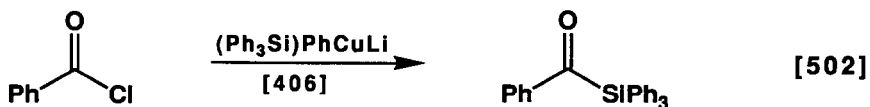

25%

Lithium tetrakis(trimethylsilyl)aluminate reacts with acid chlorides in the presence of cuprous cyanide to give acylsilanes. (Eqn. 503)

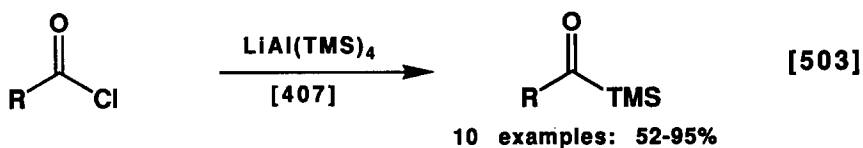

Metal-metal exchange on silyl imine gives the lithium reagent, alkylation-methanolysis of which provides acylsilanes. (Eqns. 504 and 505)

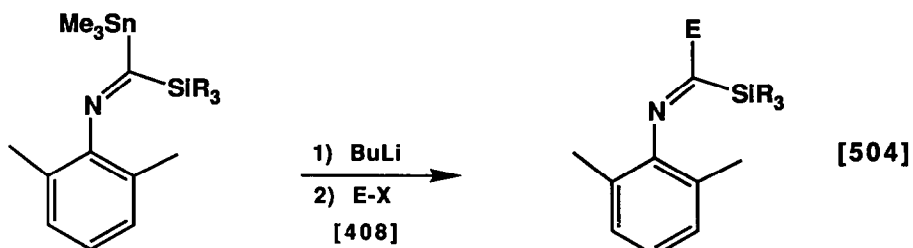

$\text{R}_3\text{Si} = \text{Me}_3\text{Si}, \text{}^t\text{BuMe}_2\text{Si}$; $\text{E-X} = \text{MeOH}, \text{TMSCl}, \text{EtBr}, \text{BuBr}$

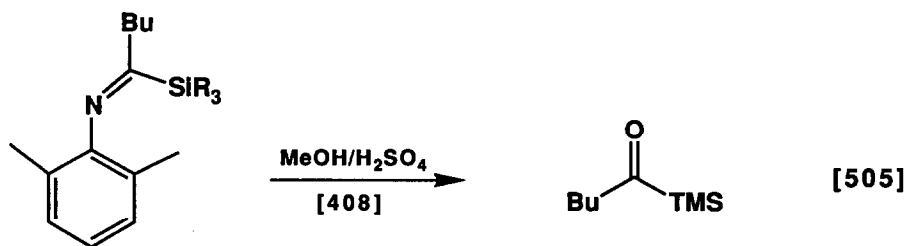

The reaction of dialkylzinc reagents with isonitriles followed by silylation of the organozinc intermediate and then hydrolysis leads to acylsilanes. (Eqns. 506 and 507)

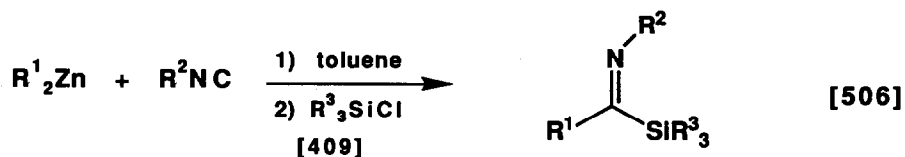

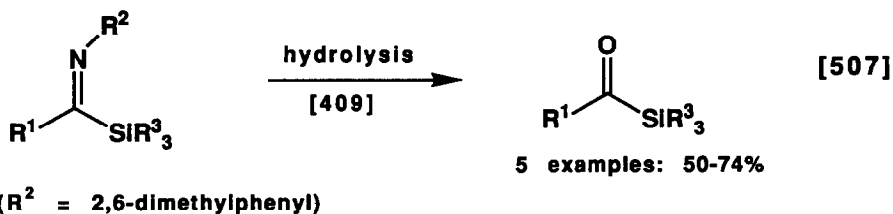

The reaction of tris(trimethylsilyl)silyllithium with dicyclopentadienyldichloro zirconium to give a silyl zirconium complex was reported. (Eqn. 508) This reacts with carbon monoxide to give an acylsilane. (Eqn. 509) Treatment of this acyl complex with anhydrous hydrochloric acid gives tris(trimethylsilyl)formylsilane, which was subjected to three reactions. (Eqns. 510-513)

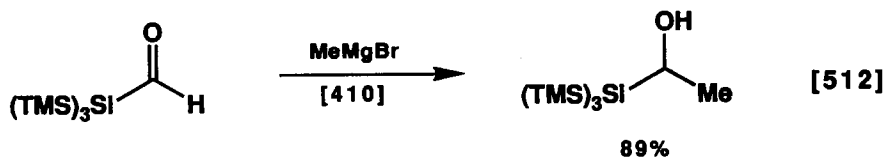
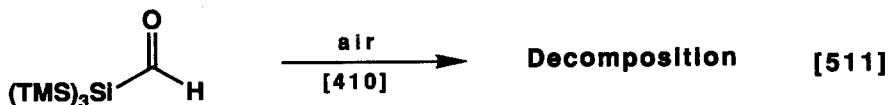
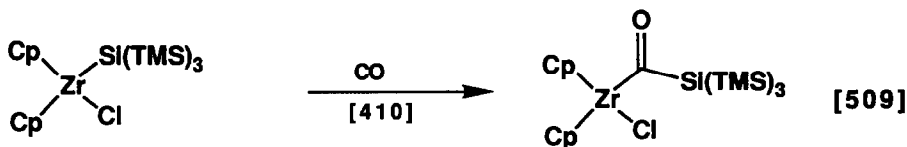
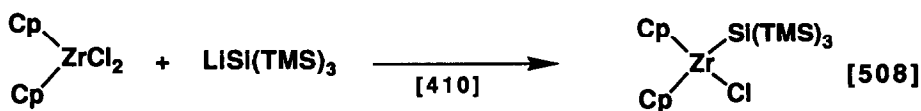

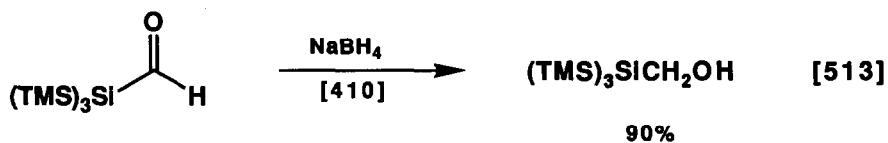

Benzyl(phenyldimethylsilyl)ketone was photolyzed in a micelle and it was found that the surviving acylsilane was enriched in ^{29}Si . (Eqn. 514)

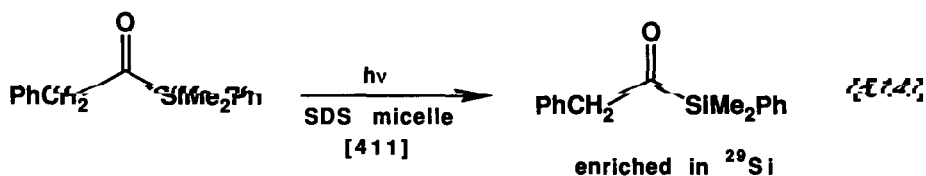

Photolysis of a 1,2-diketoacylsilane gave the siloxyketene, which could be trapped with various nucleophiles. (Eqns. 515 and 516)

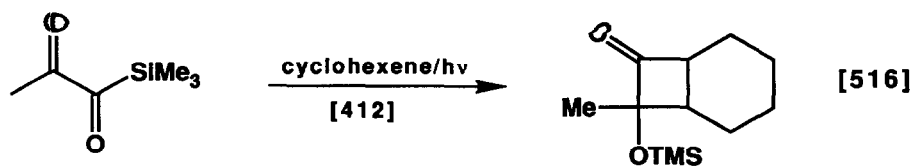
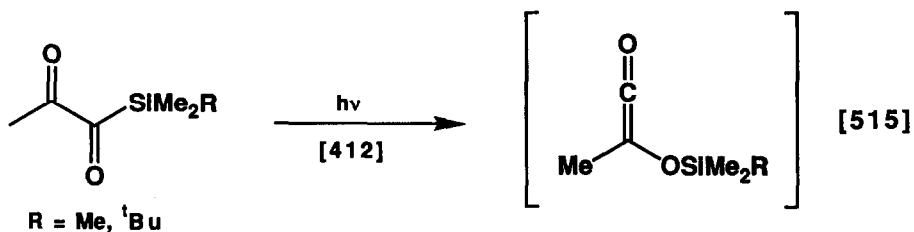

α,β -Unsaturated acylsilanes were reacted with functional organosilanes to give addition to the double bond and the enol silyl ether of the acylsilane. (Eqn. 517)

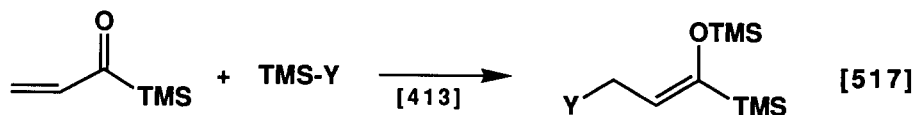

(Y = Et₂N, TMSNH, PhS, MeS, TMSS, Br, N₃, Cl₂/Ph₃P, 1-pyrrazole)

Acylsilanes were reacted with enones in the presence of tetrabutylammonium cyanide to give acylation of the β-position of the enone. (Eqn. 518)

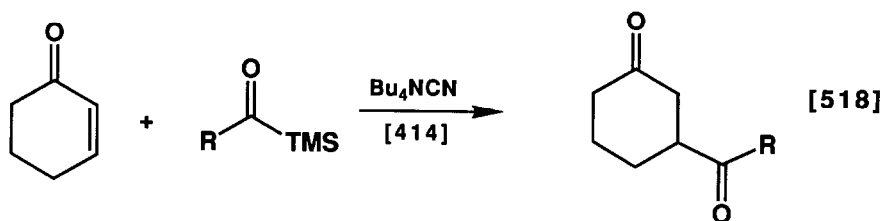

It was found that treatment of acylsilanes with tetrabutylammonium fluoride gives migration of an alkyl group from silicon to carbon along with protodesilylation resulting in secondary alcohols. (Eqn. 519)

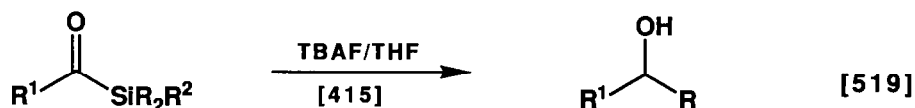

6 examples: 52-68%

(R²R₂Si = Me₃Si, Ph₂MeSi, Ph₃Si, C₅H₁₁Me₂Si, C₆H₁₃Me₂Si)

Acylsilanes with an α-methyl substituent were reacted with organolithium and organomagnesium reagents to give a highly diastereoselective reaction. The protodesilylation occurs with high stereospecificity. (Eqns. 520 and 521)

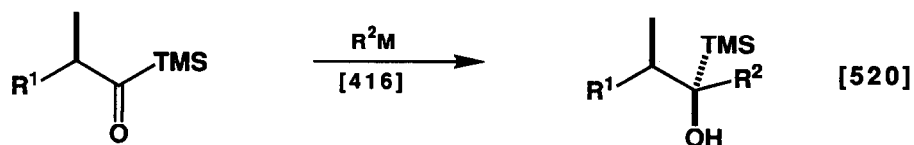



Thioacylsilanes were reacted with butadiene to give cycloaddition products. (Eqn. 522) The reaction with cyclopentadiene gave exclusively the endo silyl derivative. (Eqn. 523)

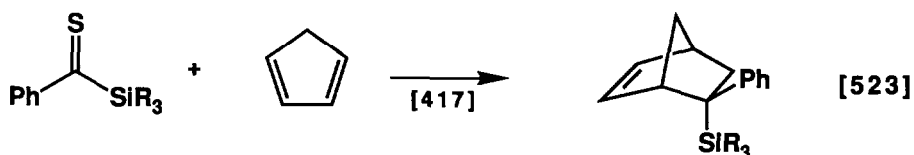
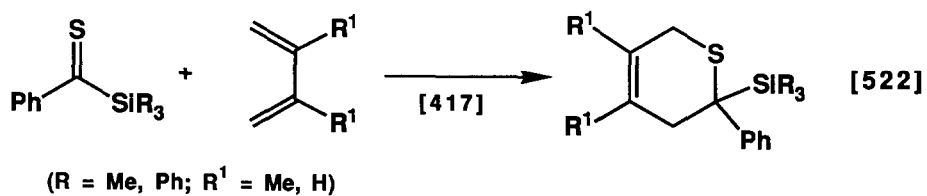

Thioacylsilanes were also cycloadded to unsaturated nitroso systems. (Eqn. 524) Treatment of the cycloadduct with fluoride ion eliminated the elements of the trialkylsilanol. (Eqn. 525)

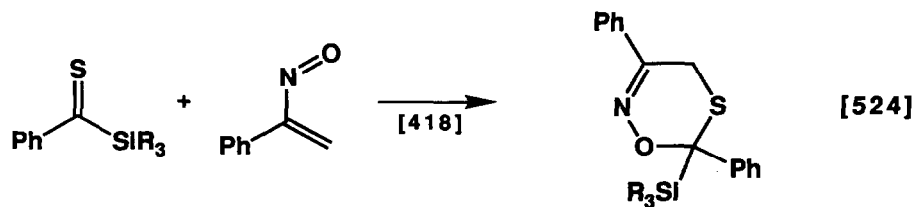

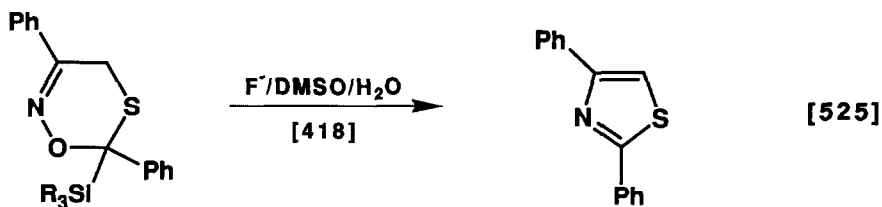

Treatment of a thioacylsilane optically active at silicon with methyllithium gave the product of methylation at sulfur with only moderate diastereoselectivity. (Eqn.

526)

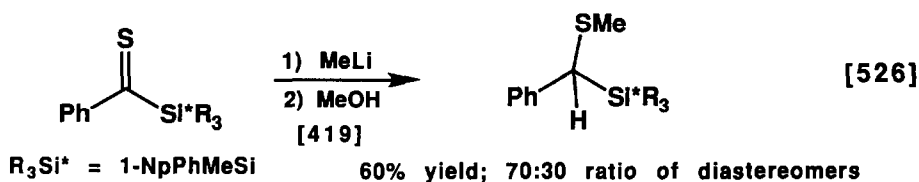

Disilanes were reacted with isocyanides to give the imines of acyl silanes. (Eqn. 527) This reaction also worked with polysilanes. (Eqn. 528)

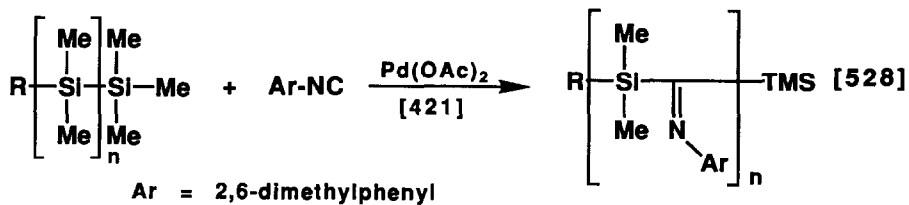
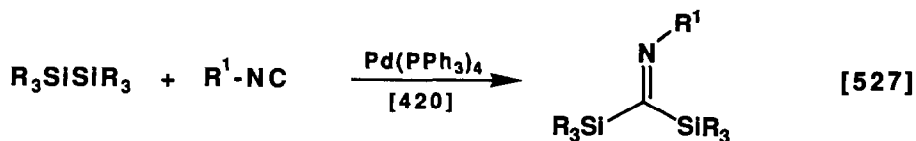

Laser photolysis of bis(triphenylsilyl) ketone showed a strong fluorescence for the S1 ($n\pi^*$) with a lifetime of 460 ns. A weak $\pi\pi^*$ fluorescence was also observed.

[422] Due to the steric effect of the mesityl groups (dimesitylmethyl)(trimethylsilyl) ketone exists in the enol form. [423]

XV. REACTIVE SPECIES

A. Radicals

Ab initio calculations on the substituent effects on the stability of silyl radicals were conducted. [424] It was found that electropositive groups such as boron, beryllium, and silicon stabilize radicals at both silicon and carbon, but that electron donating groups tend to destabilize these radicals. The configuration of the bis(trimethylsilyl)silyl radical was determined by esr studies to be nearly planar. [425] The kinetics and mechanism of gas-phase photochemical reactions between trimethylsilane and 1,1-difluoroethylene were studied. It was determined that the reaction proceeds via silyl radicals. [426] The disproportionation of the trimethylsilyl radical to dimethylsilene was studied by trapping of the silene with alcohols. [427]

B. Silylenes

Silylene (SiH_2) was detected by intracavity laser spectroscopy in the pyrolytic decomposition of silanes and organosilanes. [428] The pyrolysis of 1,1-dichloro-1-silacyclopent-3-ene showed evidence for the retro-Diels-Alder reaction in a matrix. (Eqn. 529) The dichlorosilylene was detected by infrared spectroscopy. γ -Induced radiation of dodecamethylcyclohexasilane generates dimethylsilylene. (Eqn. 530)

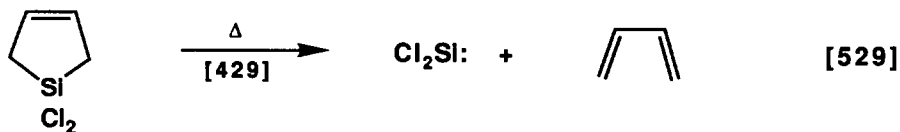



2-Furylphenylsilylene was generated by the known photochemical extrusion of hexamethyldisilane from **231**. (Eqn. 531) Trapping of this silylene with 2,3-dimethyl-1,3-butadiene gave the expected products. (Eqn. 532)

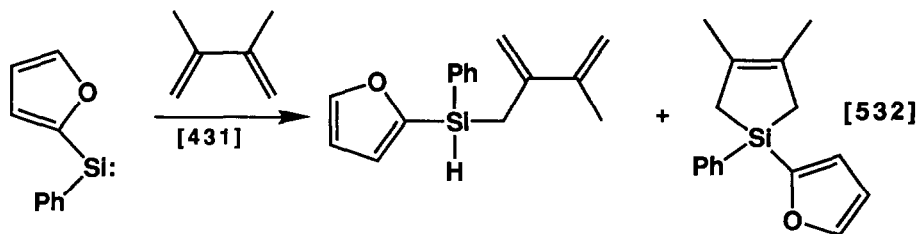
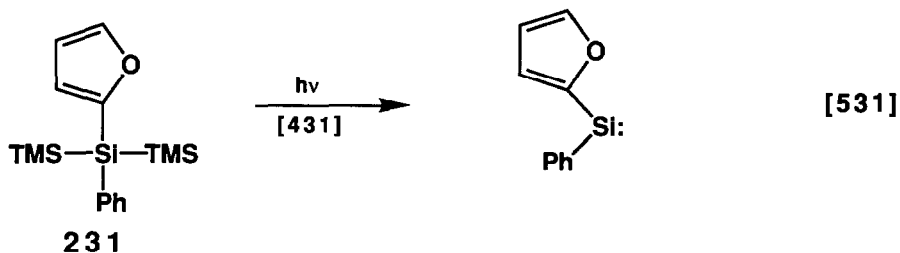

Matrix isolated di-tert-butyl diazidosilane produced the matrix isolated di-tert-butylsilylene, which showed a highly reactive singlet species with λ_{max} 480 nm. (Eqn. 533) This undergoes a photochemical insertion into one of the C-H bonds to give a silacyclopropane. (Eqn. 534) Also obtained from this reaction are di-tert-butyl diazidosilane (postulated) and N,N'-di-tert-butylsilanediimine.

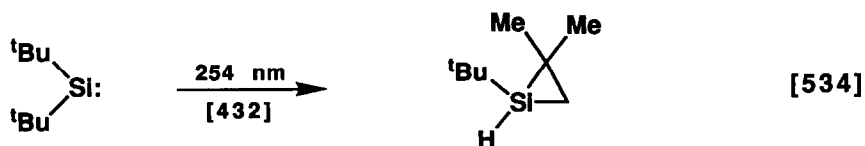

Cyclopropenylsilylenes were generated photochemically from bis(trimethylsilyl)-aryl(tri-tert-butylcyclopropenyl)silane **232**, prepared according to Eqn. 535. These silylenes undergo the typical reactions such as insertion into alcohols. (Eqn. 536) The matrix isolation of the mesityl version of these silylenes showed a λ_{max} at 450 nm. (Eqn. 537) When this species is itself photolyzed another species showing λ_{max} at 278, 328 and 400 nm is obtained. (Eqn.538) This species reacts with trimethylmethoxy-silane to give **233** (Eqn. 539) and with ethanol to give **234** (Eqn. 540) and is postulated, therefore to be 2,3,4-tris(tert-butyl)mesitylsilacyclobutadiene.

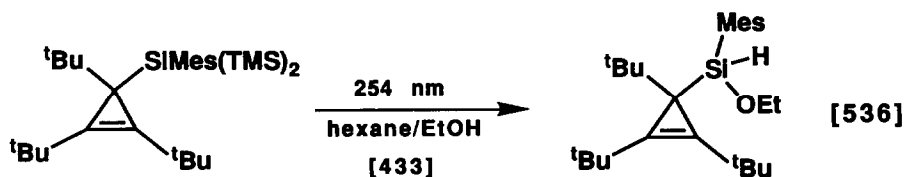
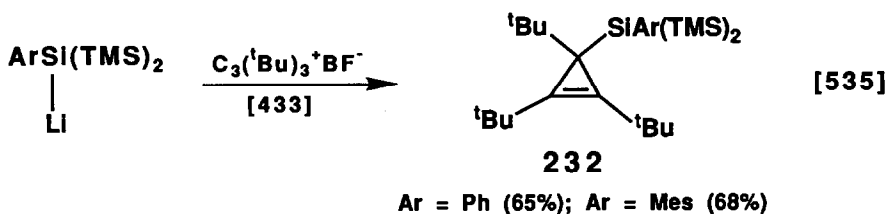

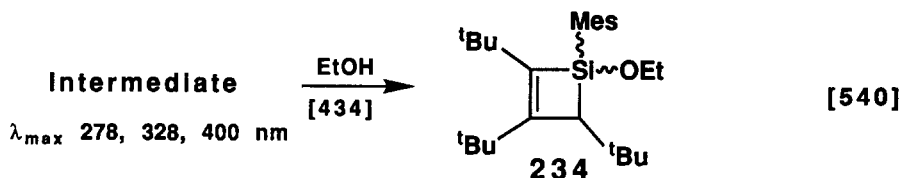
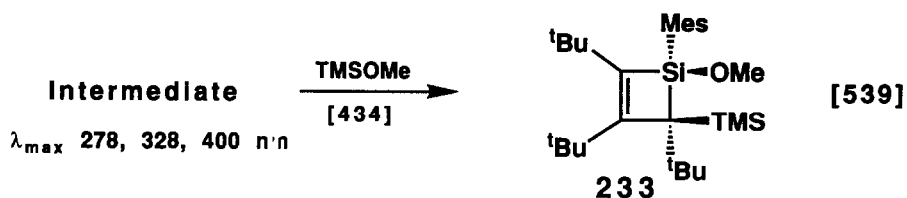
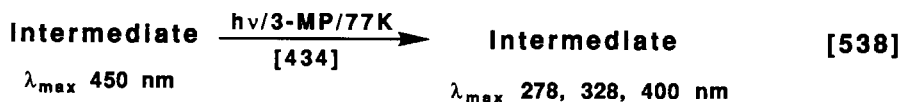
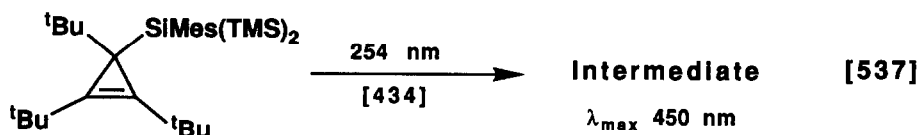

The stereochemistry of the addition of diarylsilylenes to *cis* and *trans*-2-butenes was reported. (Eqn. 541) The reaction is non-stereospecific with the *cis/trans* ratio depending on the steric bulk of the aryl groups.



The reaction of dimethylsilylene with β -pinene was reported to give both an

allylsilanes and α -pinenes with carbon monoxide with carbon monoxide. (Eqn. 542). The reaction with α -pinene gives only a single product. (Eqn. 543)

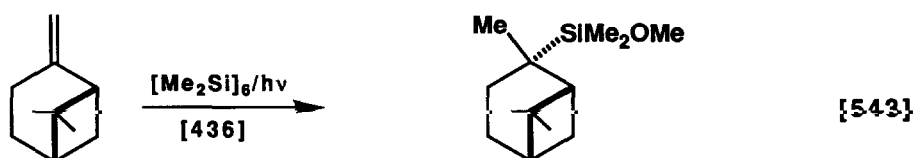
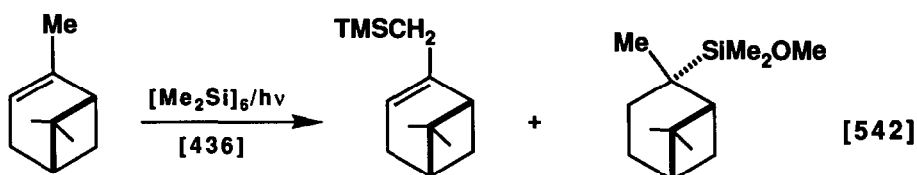

The reaction of silylenes with carbon monoxide was reported by two groups. The first reported the reaction of dimethylsilylene with carbon monoxide to give an adduct which showed a carbonyl stretch at 1962 cm^{-1} and a UV absorption at 342 nm. (Eqn. 544) Calculations indicate an Si-C bond length of 2.891 nm and a pyramidal silicon. The second reacted mesityl substituted silylenes with carbon monoxide to give an adduct which showed an absorption at 338 nm and which gave disilenes upon warming. (Eqns. 545 and 546)

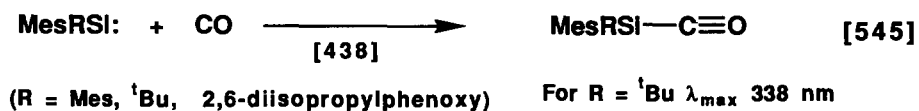
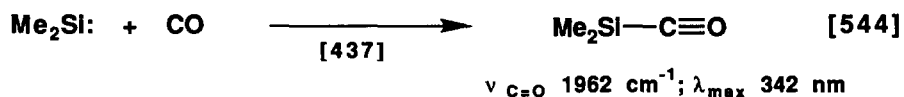



The reaction of dimesitylsilylene with oxygen in a matrix gave a product which was determined by labelling experiments to be linear in structure and not a siladioxirane. (Eqn. 547)



Dimesitylsilylene was shown to dimerize to disilenes in solvents of varying viscosities without annealing. (Eqn. 548)



Dimethylsilylene, generated from dodecamethylcyclohexasilane, was reported to give a species with λ_{max} 465 nm. This was very reactive (diffusion control) towards OH, double bonds, triple bonds and Si-H as well as towards donors such as ethyl ether, triethylamine and acetonitrile. [441] Similar results were obtained from another group. [442] The tunneling instability for the cis-trans isomerization of hydroxy-silylene was studied. [442] The heat of formation of silylene was revised to 44 kcal/mol and that of dimethylsilylene to 26 kcal/mol. [444] The mechanism of the thermal decomposition of dimethylsilane was reinterpreted to involve dimethylsilylene. [445]

C. Silenes

Reaction of tert-butyllithium with diphenylvinylchlorosilane at low temperature gives neopentyl diphenylsilene isolated as its dimer. (Eqn. 549)

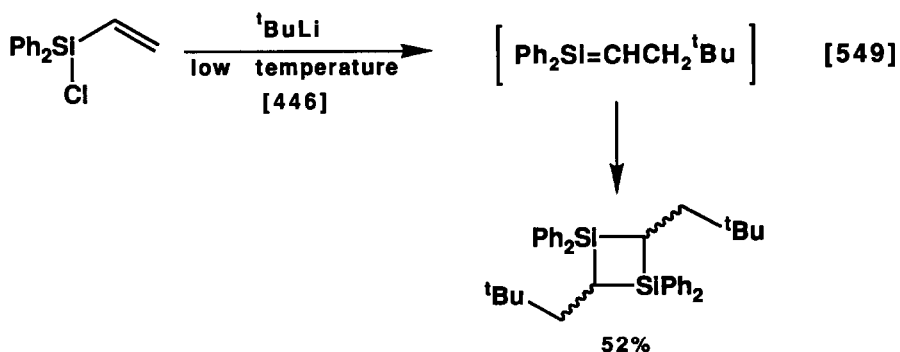

The reaction of tert-butyllithium with 1-vinyl-1-chloro-1-silacyclobutane gives neopentyl cyclobutasilene, which dimerizes in the absence of a trapping agent. (Eqn.

550) This silene can be trapped with 1,3-cyclohexadiene (both [2+4] and [2+2] cycloadducts) and with cyclopentadiene ([2+4] cycloadduct only).

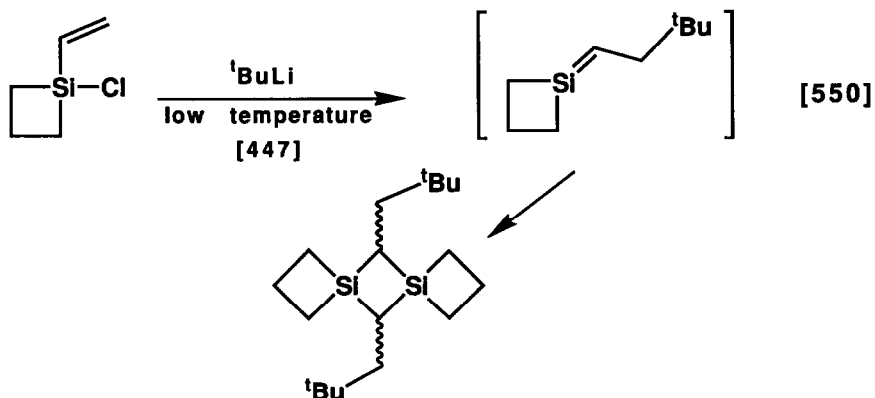

Reaction of *o,o'*-dilithiobiphenyl with 1,1-dichloro-1-silacyclobutane gives **235** (Eqn. 551) pyrolysis of which gives the silene (Eqn. 552). This dimerizes in the expected head to tail fashion in the absence of a trapping agent (Eqn. 553) and reacts

with benzophenone to give an oligomer derived from the silanone (Eqn. 554).

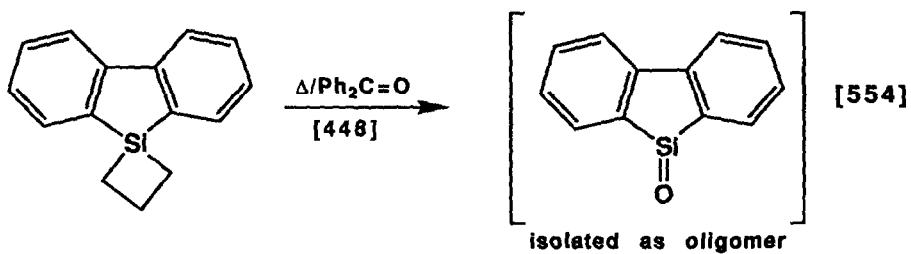
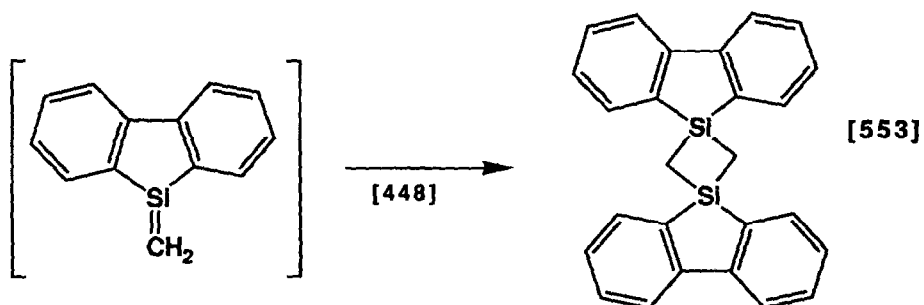
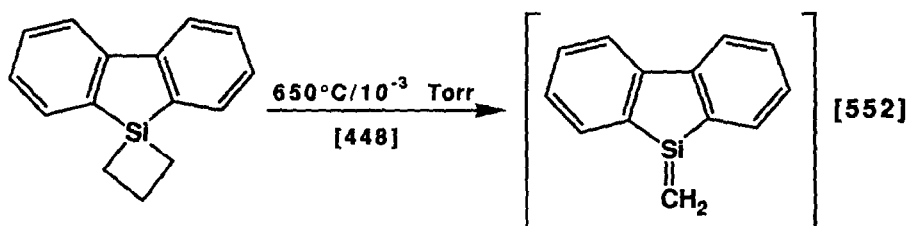
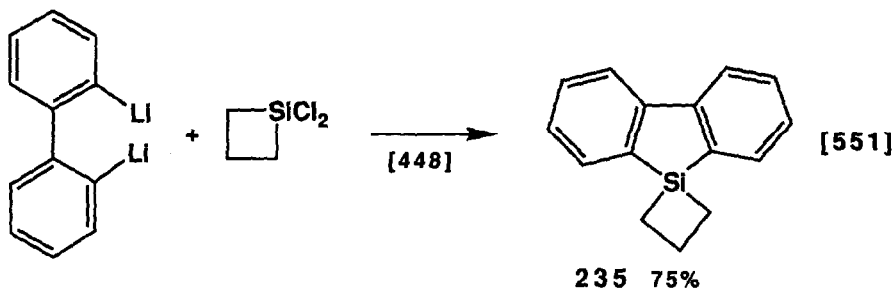

Flash vacuum pyrolysis of trimethylsilylmethyldimethylmethoxysilane gives

trimethylmethoxysilane and dimethylsilene. (Eqn. 555) On the other hand pyrolysis of methoxymethyl(trimethylsilyl)dimethylsilane leads to methoxypentamethyldisilane and methylene (carbene). (Eqn. 556) The methoxypentamethyldisilane reacts further to give dimethylsilylene and methoxytrimethylsilane. The pyrolysis of 1-trimethylsilylvinyl methyl ether gives vinylidene carbene and methoxytrimethylsilane. (Eqn. 557) Kinetic data was obtained for these reactions as well as for the thermolysis of 2-methoxytrimethylsilylethane to give ethylene and methoxytrimethylsilane. (Eqn. 558)

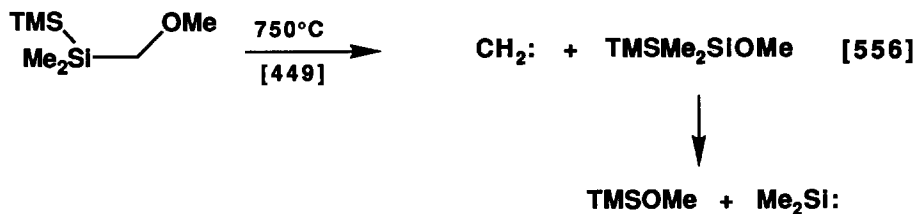
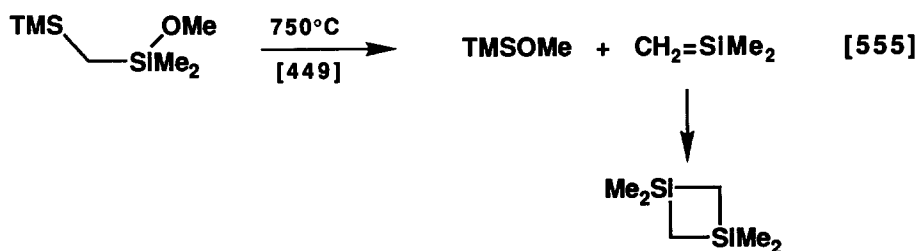

1,1-bis(trimethylsilyl)(trimethylsiloxy)phenylsilene was produced by thermolysis of **236**. (Eqn. 559)

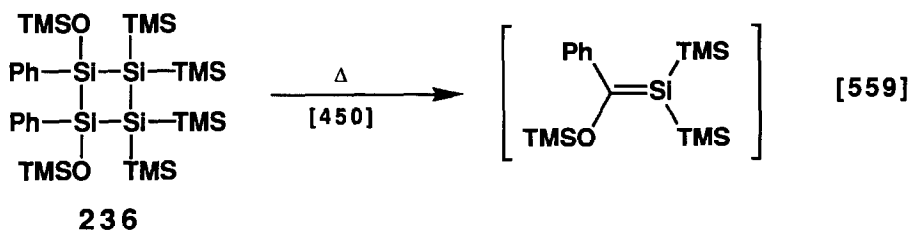

Reactions of 1,1-dimethylsilabutadiene, generated by thermolysis of 1,1-dimethyl-1-silacyclobut-2-ene were reported. In a large excess of ethylene the product of [2+4] cycloaddition and of [2+2] cycloaddition-rearrangement are observed. (Eqn. 560) The reaction with a large excess of cis or trans-2-butene gives similar products. (Eqn. 561)

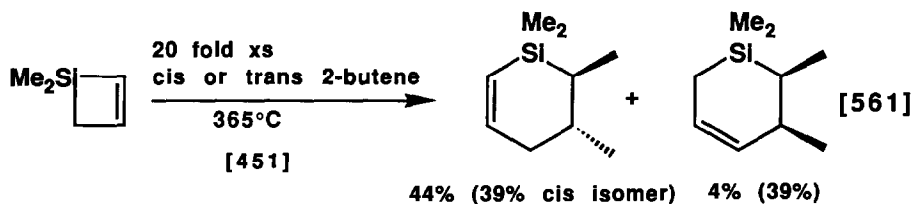
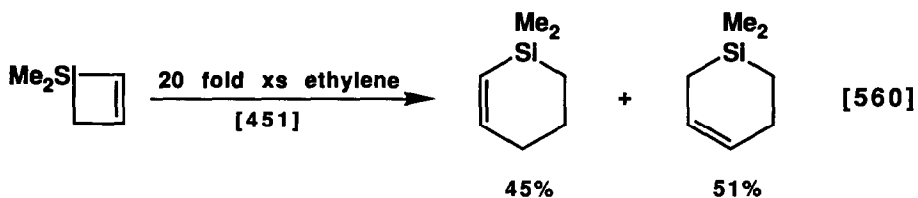

percent yields are for cis 2-butene and (trans 2-butene)

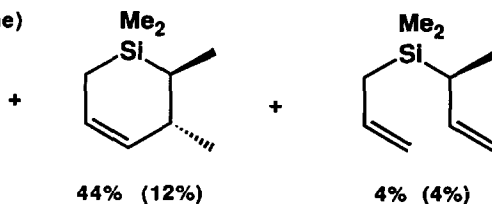

1,1-Dimethylbis(trimethylsilyl)silene was shown to react with dinitrogen oxide to give bis(trimethylsilyl)diazomethane and oligomers of dimethylsilanone. (Eqn. 562)

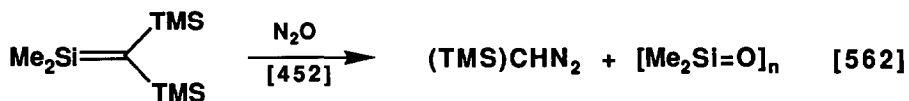

Photolysis of acyltris(trimethylsilyl)silanes gives stable silyenes. (Eqn. 563)

Their reactivity with dienes in [2+4], [2+2] and ene reactions was studied. (Eqns. 564-567)

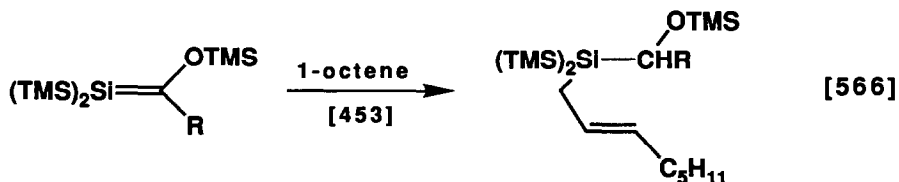
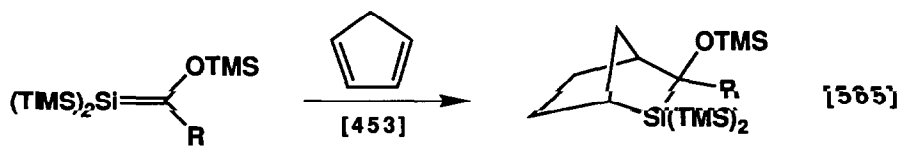
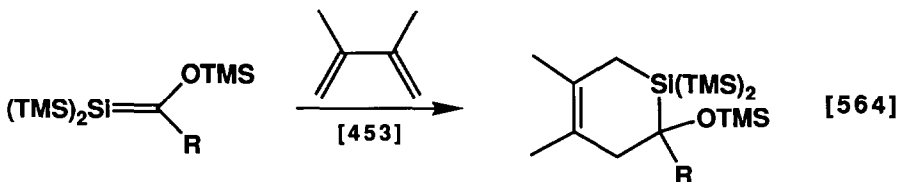

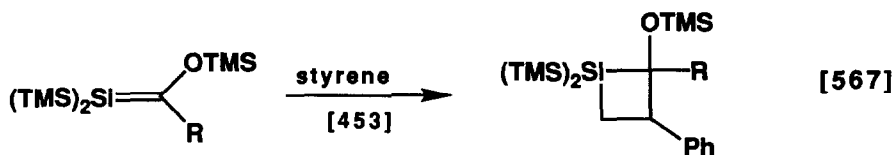

Photolysis of **237** gives silene **238** (Eqn. 568), which can either cyclize (Eqn. 569) or dimerize (Eqn. 570). Thermolysis of the cyclic material gives the acetylene and oligomers of dimethylsilanone (Eqn. 571) whereas thermolysis of the dimer splits out one molecule of the acetylene (Eqn. 572).

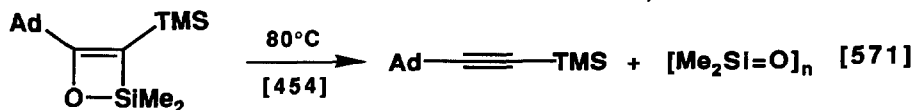
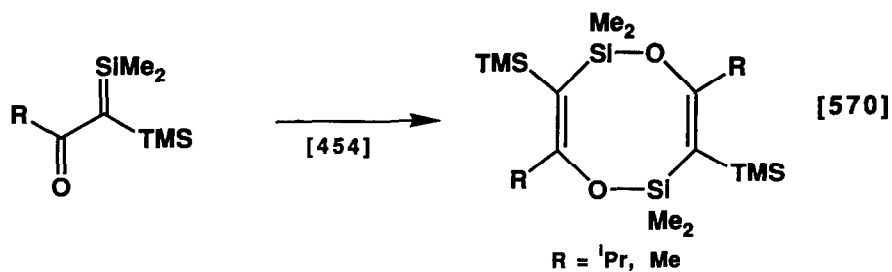
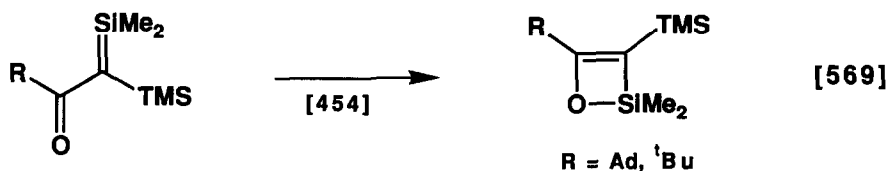
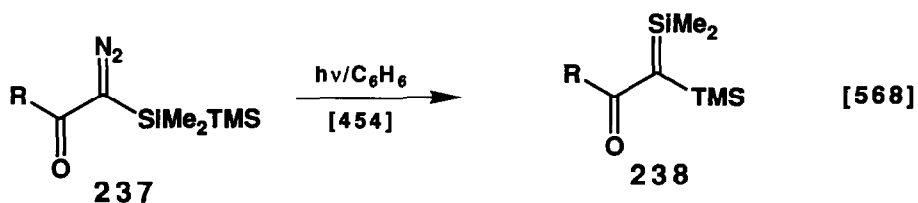

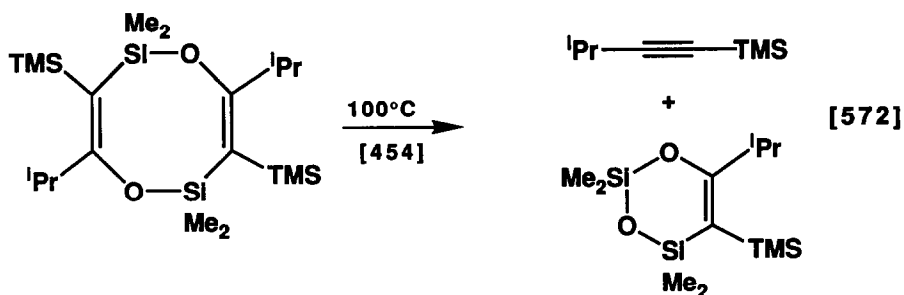

The reaction of 1,1-dimethylbis(trimethylsilyl)silene with N-trimethylsilyl-diphenylimine was reported. (Eqn. 573) The adduct of this same silene with the above imine was shown to be a source of the free silene since mild thermolysis of the adduct provides the free silene. (Eqn. 574)

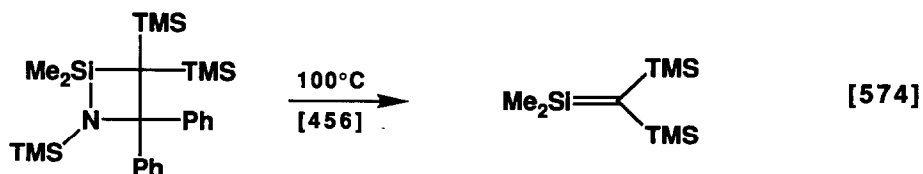
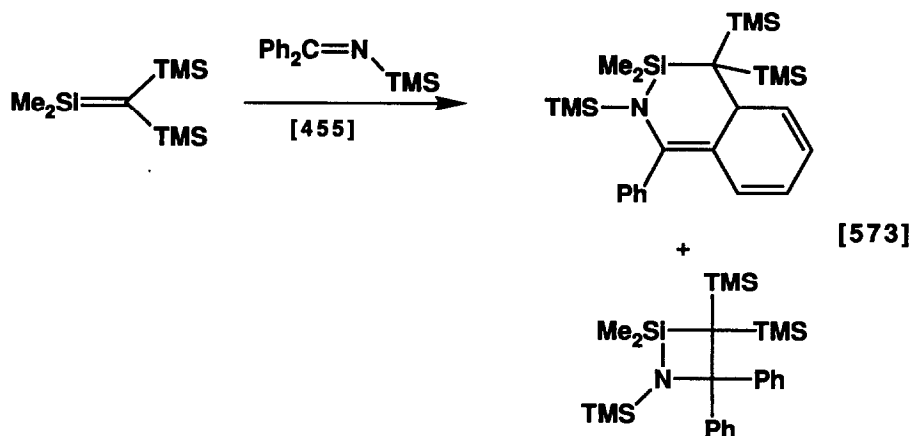

Silaaziridines were obtained from the reaction of silenes with isonitriles. The initial adduct is not stable, but undergoes rearrangement to the stable silaaziridines. (Eqns. 575 and 576)

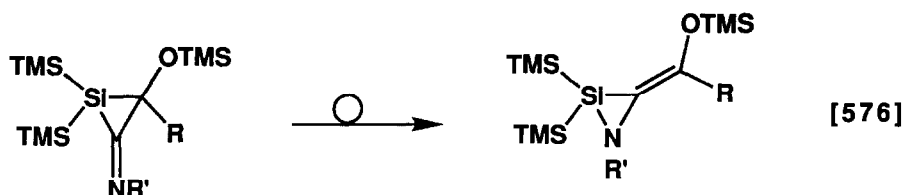
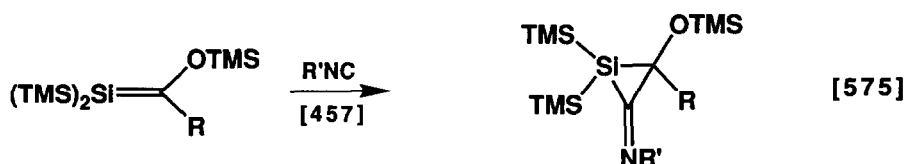

A theoretical study of silasilene showed the bent configuration for the triplet to be higher in energy than the planar configuration by ca. 2 kcal/mol. [458] Experimental evidence to support the formation of methylsilylene from silene was presented. Methylsilylene is ca. 10 kcal/mol less stable than silene. [459] In another publication, however, it is argued that the difference in energy is only ca. 4 kcal/mol. [460]

D. Disilenes

An air-stable disilene was prepared by the reaction of bis[tris(2,4,6-diisopropylphenyl)]dichlorosilanes with lithium naphthalenide. (Eqn. 577)

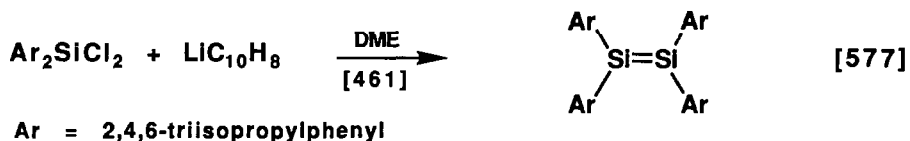

Tetrakis(2,6-dimethylphenyl)disilene was reacted with 2,6-dimethylphenyl isocyanate to give a stable disilacyclopropanimine. (Eqn. 578)

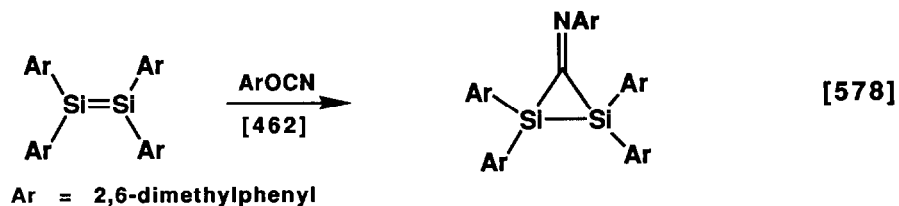

E. Silanones

Dichlorosilanone was thermally generated from benzyloxytrichlorosilane in the presence of chlorosilanes to give insertion of the dichlorosilanone into the Si-Cl bond. (Eqn. 579) In the absence of a trapping agent oligomers of dichlorosilanone are formed. (Eqn. 580) In a similar manner dimethylsilanone can be generated starting from benzyloxydimethylsilane. (Eq. 581)

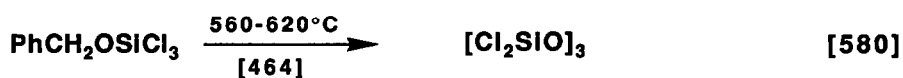
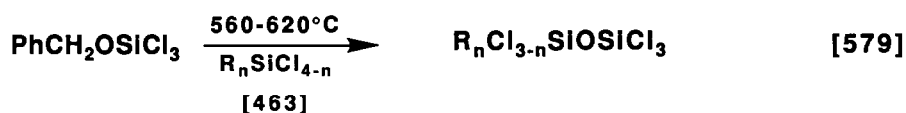

The reaction of 6-oxa-3-silabicyclo[3.1.0]hexanes with phosphinimines gives an intermediate silaoxetane, which decomposes to dimethylsilanone. (Eqns. 582-584)

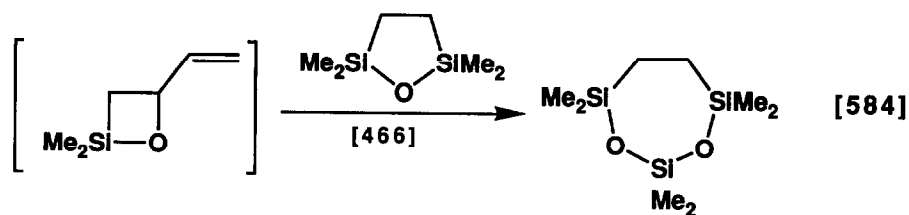
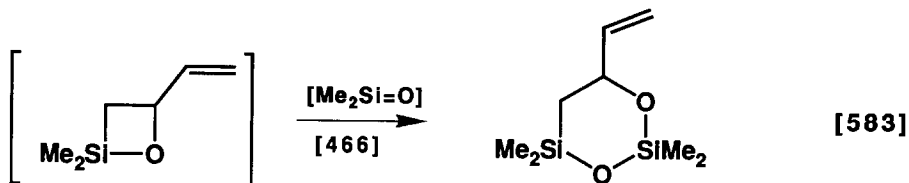
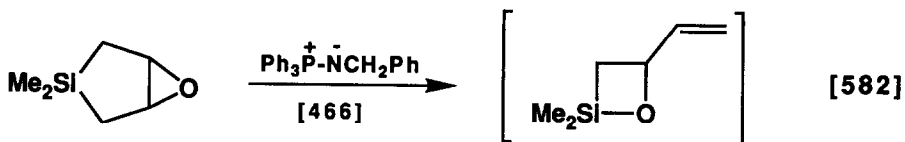

Photolysis of **239** gives dimethylthiosilanone as evidenced from trapping experiments. (Eqn. 585)

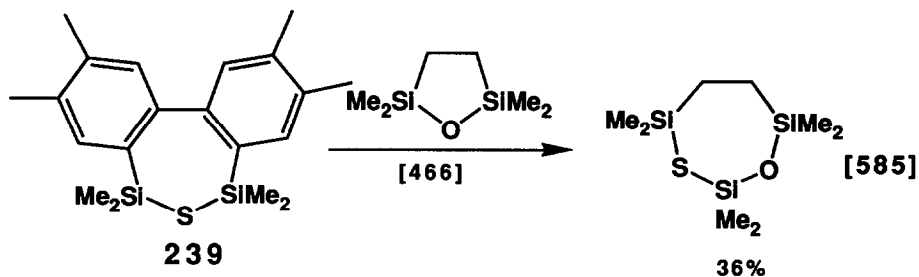

F. Miscellaneous Reactive Silanes

The stabilization energy for silabenzene has been calculated as dET for the homodesmotic reactions in which ethylene is the other reactant with trans 1,3-butadiene and trans 2-sila-1,3-butadiene as the products and where trans 1,3-butadiene is the other reactant and trans 1,3,5-hexatriene is the product. The values are 17.2 and 17.6 kcal/mol compared to 24.8 and 23.5 kcal/mol for the corresponding reactions for benzene. [468] Ab initio calculations were applied to a series of metal-substituted benzene and cyclopentadiene structures. [469] Substituted silabenzenes were subjected to ab initio calculations. [470]

Hexamethyl-1,4-disilabenzene was generated from **240** and its chemistry investigated. (Eqns. 586-590)

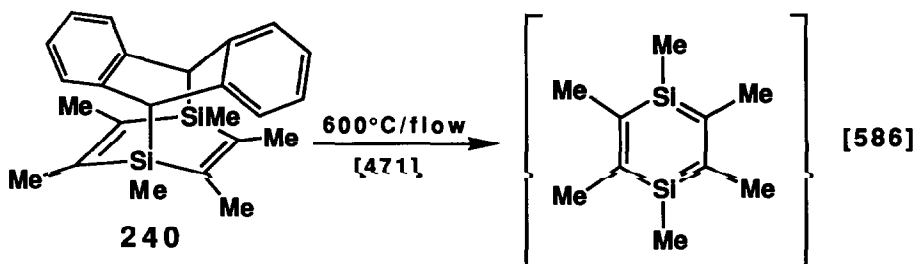

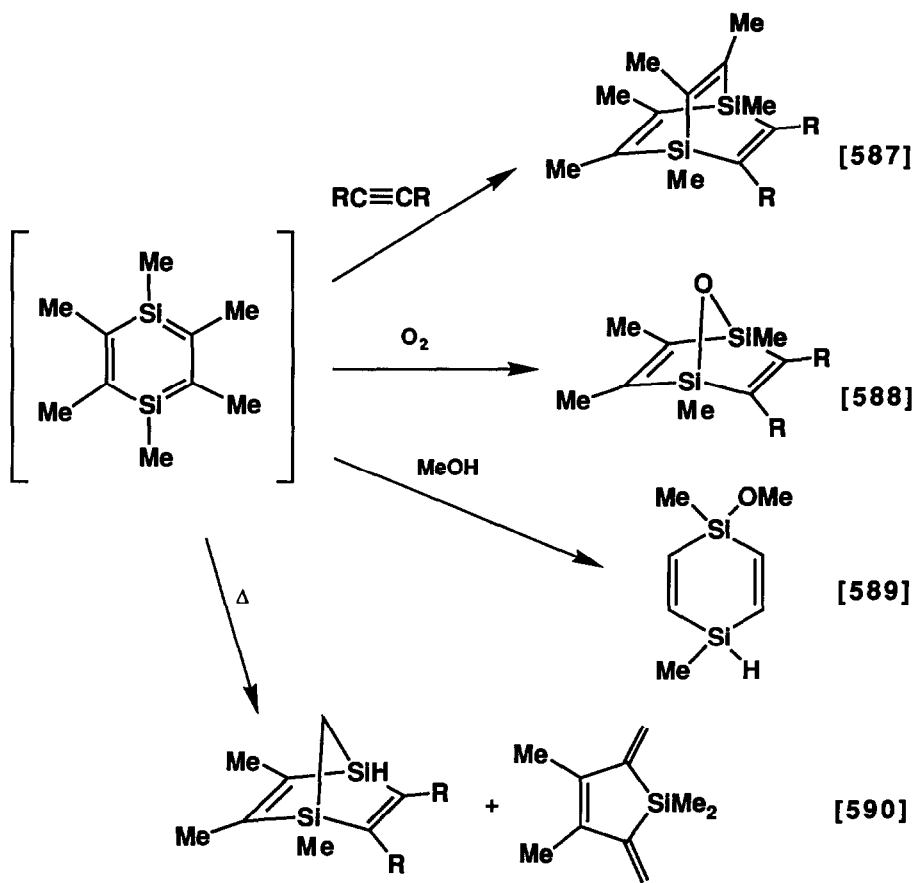

In a similar fashion dimer **241** was thermolyzed in the presence of acetylenes to give **242**. (Eqn. 591) Although the mechanism is not yet determined for this reaction it is possible that it proceeds *via* 2,3-disila-2-butyne.

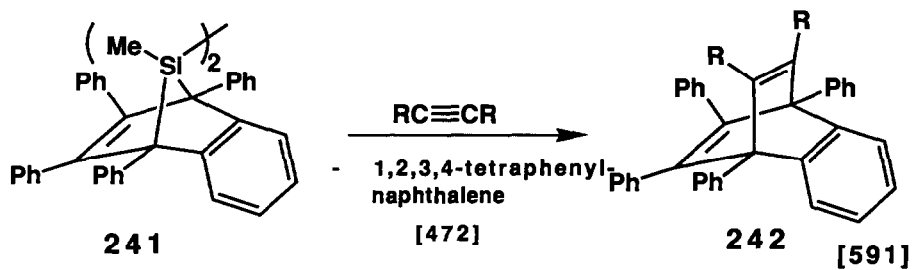

1,4-di-tert-butyl-1,4-disilabenzene, the first stable silabenzene at -100°C , was prepared. (Eqn. 592)

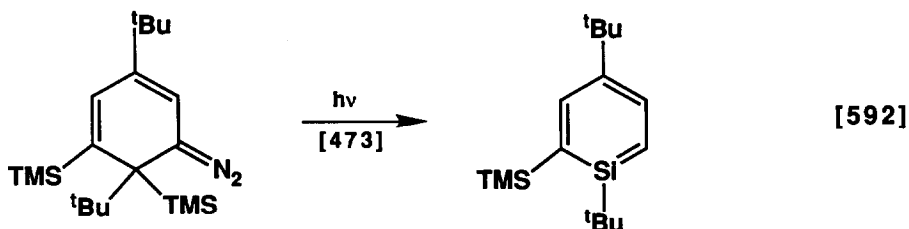

A lecture was presented and published on the theory and experiments concerning the solvolytic generation of the silicenium ion. [474] A silicenium ion was proposed for the solvolysis of 1-chloro (or 1-benzoato)-1-trimethylsilyl adamantane in which a 1,2-methyl migration from silicon to carbon occurs. [475] The first silicenium ions in solution were generated from the reaction of silanes with trityl perchlorate. [476] The ^{35}Cl and ^{37}Cl NMR spectra of triphenylsilyl perchlorate and trimethylsilyl perchlorate in sulfolane were reported. The results are consistent with a rapid exchange between associated and fully ionized forms. [477] The gas phase reactions of silicenium ions with ammonia and amines was investigated. [478] An ab initio study of the 2-silaallyl cation was reported. [479]

The silaacetate anion has been proposed as an intermediate in the reaction of (p-chlorophenyl)methylsilane diol with sodium hydroxide. (Eqn. 593)

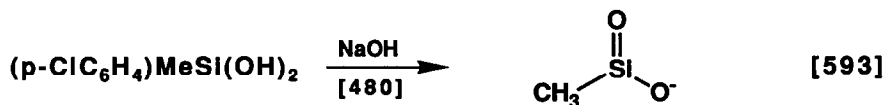

Calculations indicate that the silylacylonium ion, H_3SiCO^+ , is 18.8 kcal/mol more stable than $:\text{C}=\text{O}^+ - \text{SiH}_3$, but that the energy minimum is $\text{H}_3\text{CO}^+ = \text{Si}^-$, which is 25.8 kcal/mol more stable than the silaacylonium ion. [481] The gas-phase chemistry of the anion CHSi^- is consistent with the negative charge on the silicon atom. [482]

Photolysis of silaoxirane **243** produces the silacarbonyl ylide **244**. (Eqn. 594)
The corresponding silathiirane gives the silathiocarbonyl ylide. (Eqn. 595)

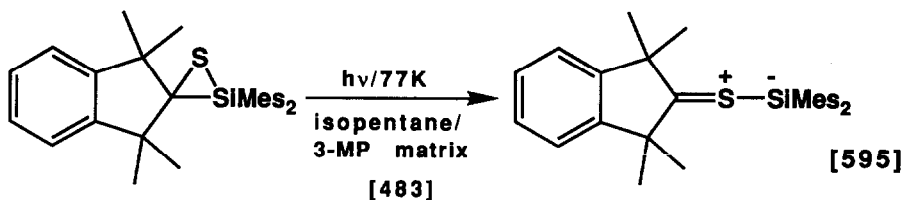
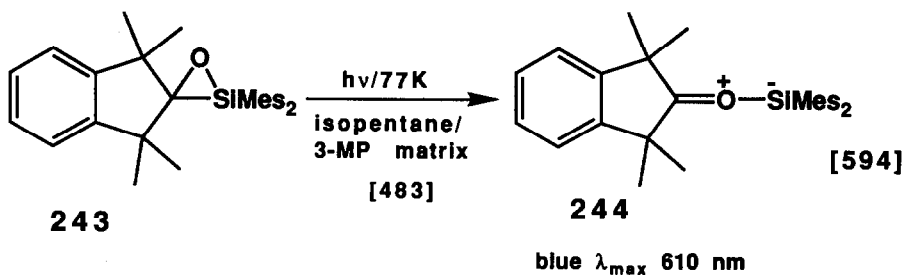

XVI. ACKNOWLEDGEMENTS

I wish to thank the library of Hüls AG for help in locating some of the articles referred to in this chapter. A special thanks goes to Loren Linder, who provided a thorough proof reading of the manuscript.

XVII. REFERENCES

1. "The chemistry of organic silicon compounds" Part 1 and Part 2, S. Patai and Z. Rappoport, Eds., John Wiley and Sons-Interscience, New York, (1989).
2. G.L. Larson "Organosilicon Survey 1985. The silicon-carbon bond" J. Organometal. Chem., **337** 195 (1987).
3. D.M. Schubert, W.S. Rees, Jr., C.B. Knobler, F.M. Hawthorne, Pure Appl. Chem., **59** 869 (1987).
4. G. Fritz, R. Biastoch, K. Stoll, T. Vaahs, D. Hanke, H.W. Schneider, Phosphorus Sulfur, **30** 385 (1987).
5. G. Fritz, Adv. Inorg. Chem., **31** 171 (1987).
6. V.E. Shklover, Yu.T. Struchkov, J. Organometal. Chem., **322** 269 (1987).
7. D. Seyferth, R.C. Hui, R. Weinstein, W.L. Wang, Nova Leopold, **59** 335 (1985). Chem. Abstr., **108**:6056t.
8. R. West., Angew. Chem., **99** 1231 (1987).
9. A. Alberti, G.F. Pedulli, Rev. Chem. Intermed., **8** 207 (1987). Chem. Abstr., **108**:56150q.
10. J. Yoshida, Yuki Gosei Kagakaku Kyokaishi, **46** 586 (1988). Chem. Abstr., **109**:169552m.
11. D. Klemm, A. Stein, Wiss. Z. Friedrich-Schiller-Univ. Jena: Naturwiss. Reihe, **36** 675 (1987). Chem. Abstr., **109**:55164y.
12. S. Murai, Y. Seki, J. Mol. Catal., **41** 197 (1987).
13. E. Lukevics, L.M. Ignatovich, Ordena Tr. Krasnogo Znameni Inst. Org. Sint., 1957-1987 75 (1987). Chem. Abstr., **108**:204652x.
14. M.D. Mizhiritski, V.O. Reikhsfel'd, Usp. Khim., **57** 803 (1988). Chem. Abstr., **109**:149579x.
15. Yu.S. Gol'dberg, V. Dirnens, E. Lukevics, J. Organometal. Chem. Libr., **20** 211 (1988).
16. K. Oshima, H. Nozaki, Kagaku, Zokan (Kyoto) 127 (1986). Chem. Abstr., **108**:56132k.
17. A. Mortreux, F. Petit, G. Buono, G. Pfeiffer, Bull. Soc. Chim. Fr., 631 (1987).
18. V. Pouzar, Chem. Listy, **82** 715 (1988). Chem. Abstr., **109**:169562q.
19. T. Hoegberg, Acta Pharm. Suec. **23** 414 (1986). Chem. Abstr., **108**:111867f.

20. H. Wurziger, Kontakte (Darmstadt) 14 (1987). Chem. Abstr., **109:170475v**.
21. H.H. Otto, Stud. Org. Chem. (Amsterdam), **28** 231 (1987). Chem. Abstr., **108:167517j**.
22. Y. Terao, M. Aono, K. Achiwa, Heterocycles, **27** 981 (1988).
23. E. Lukovics, I.D. Segal, Khim. Geterotsikl. Soedin., 5 (1987). Chem. Abstr., **108:56136q**.
24. I. Fleming, Pure Appl. Chem., **60** 71 (1988).
25. G. Stork, Bull. Chem. Soc. Jpn., **61** 149 (1988).
26. D. Schinzer, Janssen Chim. Acta, **6** 11 (1988). Chem. Abstr., **109:170495b**.
27. D. Schinzer, Synthesis, 263 (1988).
28. J. Dunogues, Bull. Soc. Chim. Fr., 659 (1987).
29. H. Nozaki, K. Utimoto, K. Oshima, K. Takai, Kenkyu Hokoku-Asahi Garasu Kogyo Gijutsu Shoreikai, **49** 27 (1986). Chem. Abstr., **108:167515g**.
30. S.I. Pennanen, Kem.-Kemi, **14** 445 (1987). Chem. Abstr., **108:167521f**.
31. E.W. Colvin, Chem. Met.-Carbon Bond, **4** 539 (1987). Chem. Abstr., **108:186785m**.
32. H. Sakurai, Kagaku, Zokan (Kyoto), 97 (1986). Chem. Abstr., **108:56131j**.
33. G.G. Furin, O.A. Vyazankina, B.A. Gostevskii, N.S. Vyazankin, Tetrahedron, **44** 2675 (1988).
34. J.R. Gasdaska, Diss. Abstr., **47** 4522 (1987). Chem. Abstr., **108:5747g**.
35. J.R. Green, Diss. Abstr., **48** 1349 (1987). Chem. Abstr., **109:93128e**.
36. P.E. Holmes, Diss. Abstr., **48** 1687 (1987). Chem. Abstr., **109:93129f**.
37. M.W. Wannamaker, Diss. Abstr., **48** 143 (1987). Chem. Abstr., **108:37914a**.
38. A.C. Castaneda, Diss. Abstr., **48** 2317 (1988). Chem. Abstr., **109:170525m**.
39. J.W. Ullrich, Diss. Abstr., **47** 1069 (1986). Chem. Abstr., **106:18902n**.
40. J.F. Cormier, Diss. Abstr., **48** 2973 (1988). Chem. Abstr., **109:149965v**.
41. D. Stossel, Diss. Abstr., **48** 2979 (1988). Chem. Abstr., **109:190478b**.
42. C.S. John, Diss. Abstr., **48** 1959 (1988). Chem. Abstr., **109:170631t**.
43. K-H.P. Chu, Diss. Abstr., **48** 437 (1987). Chem. Abstr., **108:6122m**.

44. D.J. Pollart, Diss. Abstr., **48** 1689 (1987). Chem. Abstr., **109**:93130z.
45. L.R. Robinson, Diss. Abstr., **48** 1983 (1988). Chem. Abstr., **109**:170524k.
46. M.W. Ensinger, Diss. Abstr., **48** 2648 (1988). Chem. Abstr., **109**:149605c.
47. T.E. Barta, Diss. Abstr., **48** 1684 (1988). Chem. Abstr., **109**:73047z.
48. T.F. Bates, Diss. Abstr., **48** 681 (1987). Chem. Abstr., **108**:167558y.
49. B.J. Rappoli, Diss. Abstr., **48** 2969 (1988). Chem. Abstr., **109**:149751x.
50. J.C. Easdon, Diss. Abstr., **48** 2973 (1988). Chem. Abstr., **109**:149667z.
51. S.B. Choe, Diss. Abstr., **48** 1041 (1987). Chem. Abstr., **109**:23111v.
52. A.N. Polivanov, N.N. Troitskaya, E.V. Los, N.N. Silkina, A.S. Shapatin, M. Gavars, O.D. Gracheva, A.G. Trufanov, V.N. Bocharov, Zh. Obshch. Khim., **57** 1570 (1987). Chem. Abstr., **109**:6582g.
53. J.S. Ferlut, Fr. Demande FR 2,601,955 (C1. C07F7/12) 1986. Chem. Abstr., **109**:73653u.
54. G.E. Nelson, U.S. US 4,711,966 (C1 556-478; C07F7/08) 1987. Chem. Abstr., **108**:204832f. and G.E. Nelson, U.S. US 4,711,965 (C1 556-478; C07F7/08) 1987. Chem. Abstr., **108**:204833g.
55. J.P. Pillot, C. Biran, E. Bacque, P. Lapouyade, J. Dunogues, Ger. Offen. DE 3,717,265 (C1 C07F7/12) 1987. Chem. Abstr., **108**:167681h.
56. A. Boudin, G.Cerveau, R.J.P. Corriu, Organometallics., **7** 1165 (1988).
57. K. Kobayashi, T. Kato, S. Masuda, Kenkyu Shuroku-Ashikaga Kogyo Daigaku, 107 (1986). Chem. Abstr., **108**:21949e.
58. S. Pillmann, U. Klingebiel, J. Organometal. Chem., **323** 1 (1987).
59. E.W. Della, J. Tsanaktsidis, Organometallics., **7** 1178 (1988).
60. Z.N. Parnes, V.S. Romanova, M.E. Vol'pin, Zh. Org. Khim., **24** 295 (1988). Chem. Abstr., **109**:109883k.
61. Y. Hatanaka, T. Hiyama, Tetrahedron Lett., **29** 97 (1988).
62. A.V. Tarakanova, S.V. Baranova, T. Pehk, O.B. Dogadin, N.S. Zefirov, Zh. Org. Khim., **23** 515 (1987). Chem. Abstr., **108**:21362h.
63. J.E. MacDonald, G.S. Poindexter, Tetrahedron Lett., **28** 1851 (1987).
64. M.R. Frierson, M.R. Imam, V.B. Zalkow, N.L. Allinger, J. Org. Chem., **53** 5248 (1988).

65. R.J. Unwalla, S. Profeta, Jr., F.K. Cartledge, *ibid.*, **53** 5658 (1988).
66. J.A. Boatz, M.S. Gordon, *J. Phys. Chem.*, **92** 3037 (1988).
67. J.A. Boatz, M.S. Gordon, R.L. Hilderbrandt, *J. Am. Chem. Soc.*, **110** 352 (1988).
68. S. Nagase, M. Nakano, T. Kudo, *J. C. S., Chem. Commun.*, 60 (1987).
69. J.C. Sheldon, R.N. Hayes, J.H. Bowie, C.H. DePuy, *J. C. S., Perkin Trans, 2*, 275 (1987).
70. R. Orlando, F. Strobel, D.P. Ridge, B. Munson, *Org. Mass Spectrom.*, **22** 597 (1987).
71. K. Shina, *Jpn. Kokai Tokkyo Koho JP 62,223,185 [87,223,185] (C1 C07F7/08) 1986. Chem. Abstr.*, **109**6727h.
72. D.B. Azarian, C. Eaborn, P.D. Lickiss, *J. Organometal. Chem.*, **330** 1 (1987).
73. B.F. Buerr, Y.S. Chung, A.W. Czarnik, *J. Org. Chem.*, **53** 2120 (1988).
74. G.E. Carr, R.D. Chambers, T.F. Holmes, D.G. Parker, *J. Organometal. Chem.*, **325** 13 (1987).
75. E.J. Bures, B.A. Keay, *Tetrahedron Lett.*, **28** 5965 (1987).
76. A. Dondoni, G. Fantin, M. Fogagnolo, A. Medici, P. Pedrini, *J. Org. Chem.*, **53** 1748 (1988).
77. W. Chen, M.P. Cava, *Tetrahedron Lett.*, **28** 6025 (1987).
78. M. Zeldin, J.M. Xu, C.X. Tian, *J. Organometal. Chem.*, **326** 341 (1987).
79. U. Wannagat, D. Wiese, G. Struckmeier, U. Thewalt, T. Debaerdemaeker, *Liebigs Ann. Chem.*, 241 (1988).
80. H. Oehme, H. Weiss, *J. Organometal. Chem.*, **319** C16 (1987).
81. A.G.M. Barrett, I.A. O'Neil, *J. Org. Chem.*, **53** 1815 (1988).
82. O.G. Yarosh, T.D. Burnashova, M.G. Voronkov, *Izv. Nauk Akad. SSSR*, 1115 (1987). *Chem. Abstr.*, **108**:204674f.
83. L. Fajari, J. Riera, C. Miravittles, E. Molins, *J. C. S., Chem. Commun.*, 143 (1987).
84. K. Takanishi, H. Urabe, I. Kuwajima, *Tetrahedron Lett.*, **28** 2281 (1987).
85. R. Leardini, D. Nanni, A. Tundo, G. Zanardi, *Synthesis*, 333 (1988).
86. J. Yoshida, K. Muraki, H. Funahashi, N. Kawabata, *J. Org. Chem.*, **53** 3996 (1988).
87. E.A. Chernyshev, N.G. Komalenkova, V.A. Sharapov, A.I. Gusev, A.V. Kosin, *Izv. Nauk Akad. SSSR*, **57** 1730 (1987). *Chem. Abstr.*, **109**:93107x.

88. C.J. Moody, P. Shah, P. Knowles, *Tetrahedron Lett.*, **29** 2693 (1988).
89. T. Sakaura, Y. Tokunaga, T. Sodeyama, M. Tanaka, *Chem. Lett.*, 2375 (1987).
90. H. Sakurai, K. Sakamoto, M. Kira, *ibid.*, 983 (1987).
91. S. Fornarini, *J. Org. Chem.*, **53** 1314 (1988).
92. B. Bennetau, M. Krempp, J. Dunogues, *J. Organometal. Chem.*, **332** 263 (1987).
93. R. Calas, J. Gerval, *C. R. Acad. Sci., Ser. 2* **305** 1423 (1987).
94. M.J. Sharp, W. Cheng, V. Snieckus, *Tetrahedron Lett.*, **28** 5093 (1987).
95. I. Fleming, P. Sanderson, *ibid.*, **28** 4229 (1987).
96. P.W. Rabideau, G.L. Karrick, *ibid.*, **28** 2481 (1987).
97. E.J. Bures, B.A. Keay, *ibid.*, **29** 1247 (1988).
98. M.P. Sibi, K. Shankaran, B.I. Alo, *ibid.*, **28** 2933 (1987).
99. D. Liotta, W. Ott, *Synthetic Commun.*, **17** 1655 (1987).
100. V.V. Bardin, I.V. Stennikova, G.G. Furin, *Zh. Obshch. Khim.*, **57** 1580 (1987).
Chem. Abstr., **108**:167557x.
101. W. Schacht, D. Kaufmann, *J. Organometal. Chem.*, **331** 139 (1987).
102. R. Neidlein, W. Wirth, *Helv. Chim. Acta*, **69** 1851 (1986).
103. T. Veszpremi, L. Nyulaszi, J. Nagy, *J. Organometal. Chem.*, **331** 175 (1987).
104. R. Gleiter, W. Schaefer, G. Krennrich, H. Sakurai, *J. Am. Chem. Soc.*, **110** 4117 (1988).
105. I.G. Lorents, S.B. Bulgarevich, D.Ya. Movshovich, N.P. Erchak, L.N. Khokhlova, O.A. Osipov, E. Lukevics, *Zh. Obshch. Khim.*, **57** 556 (1987). *Chem. Abstr.*, **108**:94623d.
106. C. Biran, M. Fourtignon, B. Efendene, J. Dunogues, *J. Organometal. Chem.*, **344** 145 (1988).
107. A.E. Aliev, A.A. Fomichev, A.V. Varlamov, N.S. Prostakov, *Khim. Geterotsikl. Soedin*, 1577 (1987). *Chem. Abstr.*, **109**:110496t.
108. A.P. Laws, R. Taylor, *J. C. S., Perkin Trans, 2*, 1691 (1987).
109. T. Suzuki, K. Takase, K. Takahashi, A.P. Laws, *ibid.*, 697 (1988).
110. R. Gruber, G. Kirsch, *Bull. Soc. Chim. Fr.*, 498 (1987).

111. K. Maruoka, T. Itoh, T. Shirasaka, H. Yamamoto, *J. Am. Chem. Soc.*, **110** 310 (1988).
112. W.K. Moberg, G.S. Basarab, J. Cuomo, P.H. Liang, *ACS Symp. Ser.*, **355** (1987). *Chem. Abstr.*, **109**:149602z.
113. H. Franke, H. Joppien, *Ger. Offen. DE 3,604,781 (C1 C07F7/08)*. *Chem. Abstr.*, **108**:132041x.
114. D.J. Dumas, M.P. Moon, *Eur. Pat. Appl. EP 212,779 (C1 C07D409/12)*. *Chem. Abstr.*, **108**:56117j.
115. S. M. Siefert, *U.S. US 4,709,068 (C1 556-447; C07F7/08)*. *Chem. Abstr.*, **108**:94775e.
116. M. Suzuki, T. Imai, *U.S. US 4,736,049 (C1 556-479; C07F7/08)* (1986). *Chem. Abstr.*, **109**:54954b.
117. V.A. Kovyazin, V.M. Kopylov, V.V. Kirëev, A.V. Kisin, N.V. Alekseev, A.V. Gorshkov, *Zh. Obshch. Khim.*, **57** 1735 (1987). *Chem. Abstr.*, **109**:23011n.
118. W. Caseri, P.S. Pregosin, *Organometallics.*, **7** 1373 (1988).
119. Z.M. Michalska, *Mezhdunar. Simp. Suyazi Gomogennym Getero. Katal.*, **5th 2** 203 (1986). *Chem. Abstr.*, **108**:131895s.
120. V.S. Brovko, N.V. Vorob'ev-Desyatovskii, Yu.N. Kukushkin, *Zh. Prikl. Khim.* **60** 2554 (1987). *Chem. Abstr.*, **109**:93125b.
121. I. Iovel, Yu. Goldberg, M. Shymanska, E. Lukevics, *Appl. Organomet. Chem.*, **1** 371 (1987).
122. B. Marciniac, Z. Foltynowics, W. Urbaniak, J. Perkowski, *ibid.*, **1** 267 (1987).
123. J.M. Chance, D.L. Linebarrier, T.A. Nile, *Transition Met. Chem.*, **12** 276 (1987).
124. B. Mariniac, Z. Foltynowics, W. Urbaniak, *J. Mol. Catal.*, **42** 195 (1987).
125. S. Chen, F. Lu, *Bopuxue Zazhi*, **4** 7 (1987). *Chem. Abstr.*, **108**:131900q.
126. M.A. Galkina, E.T. Chukovska, R.Kh. Freidlina, *Izv. Nauk Akad. SSSR*, 1095 (1987). *Chem. Abstr.*, **109**:6573e.
127. G.I. Magomedov, O.V. Shkol'nik, L.M. Khananashvili, L.I. Nakaidze, M.G. Katsitadze, *Zh. Obshch. Khim.*, **58** 104 (1988). *Chem. Abstr.*, **110**:23948u.
128. M. Licchelli, A. Greco, *Tetrahedron Lett.*, **28** 3719 (1987).
129. J.S. Bradshaw, K.E. Krzysztof, R.L. Bruening, B.J. Tarbet, P.B. Savage, R.M. Izatt, *J. Org. Chem.*, **53** 3190 (1988).

130. K. Tamao, Y. Nakagawa, H. Arai, N. Higuchi, Y. Ito, *J. Am. Chem. Soc.*, **110** 3712 (1988).
131. M.G. Voronkov, S.V. Kirpichenko, V.V. Keiko, A.I. Albanov, *Zh. Obshch. Khim.*, **57** 710 (1987). *Chem. Abstr.*, **108**:21953b.
132. M.J. Fernandez, L.A. Oro, B.R. Manzano, *J. Mol. Catal.*, **45** 7 (1988).
133. M.I. Dzheliya, L.V. Baramidze, S.Kh. Kiladze, *Soobshch. Akad. Nauk Gruz SSR* **126** 557 (1987). *Chem. Abstr.*, **109**:23006q.
134. F.A. Kuli-Zade, A.A. Ragimov, I.A. Khudayarov, O.V. Askerov, *Azerb. Khim. Zh.*, **73** (1986). *Chem. Abstr.*, **109**:54824j.
135. M.G. Veliev, A.M. Garamanov, O.V. Askerov, M.M. Guseinov, *Dokl. Akad. Nauk Az. SSR* **42** 32 (1986). *Chem. Abstr.*, **108**:150540p.
136. I. Kovacs, A. Sisak, F. Ungvary, L. Marko, *Organometallics.*, **7** 1025 (1988).
137. H. Brunner, A. Kuerzinger, S. Mahboobi, W. Wiegrebe, *Arch. Pharm.* **321** 73 (1988). *Chem. Abstr.*, **109**:38011m.
138. A.F.M.M. Rahman, S.B. Wild, *J. Mol. Catal.*, **39** 155 (1987).
139. S.A. Miller, R.C. Gadwood, *J. Org. Chem.*, **53** 2214 (1988).
140. N.S. Simpkins, *Tetrahedron Lett.*, **28** 989 (1987).
141. C. Najera, M. Yus, *ibid.*, **28** 6709 (1987).
142. J.A. Miller, W. Leong, G. Zweifel, *J. Org. Chem.*, **53** 1839 (1988).
143. T.N. Mitchell, W. Reimann, *J. Organometal. Chem.*, **322** 151 (1987).
144. Z.J. Ni, T.Y. Luh, *J. Org. Chem.*, **53** 2129 (1988).
145. T. Kazuhiko, K. Yasutaka, O. Takashi, U. Kiitiro, *Tetrahedron Lett.*, **28** 1443 (1987).
146. K. Tamao, E. Nakajo, Y. Ito, *J. Org. Chem.*, **53** 414 (1988).
147. I. Fleming, K. Takaki, A.P. Thomas, *J. C. S., Perkin Trans.*, **1**, 2269 (1987).
148. K. Fugami, K. Oshima, K. Utimoto, H. Nozaki, *Tetrahedron Lett.*, **27** 2161 (1986).
149. Y. Hatanaka, T. Hiyama, *ibid.*, **28** 4715 (1987).
150. J. Barluenga, J.L. Fernandez-Simon, J.M. Concellon, M. Yus, *Synthesis*, **234** (1988).
151. S.V. Ponomarev, M.V. Erikova, S.N. Nikolaeva, R. Zel, A.S. Kostyuk, *Zh. Obshch. Khim.*, **57** 1741 (1987).

152. J. Van der Louw, J. Van der Baan, F. Bickelhaupt, G.W. Klumpp, *Tetrahedron Lett.*, **28** 2889 (1987).
153. J. Mulzer, K.D. Graske, B. Kirste, *Liebigs Ann. Chem.*, 891 (1988).
154. M.E. Kraft, *J. Am. Chem. Soc.*, **110** 968 (1988).
155. E. Negishi, L.D. Boardman, H. Sawada, V. Bagheri, A.T. Stoll, J.M. Tour, C.L. Rand, *Ibid.*, **110** 5383 (1988).
156. P. Binger, E. Sternberg, U. Wittig, *Chem. Ber.*, **120** 1933 (1987).
157. D.P. Curran, S.C. Kuo, *Tetrahedron*, **43** 5653 (1987).
158. D.P. Curran, C.T. Chang, *Tetrahedron Lett.*, **28** 2477 (1987).
159. E. Campi, N.J. Fitzmaurice, W.R. Jackson, P. Perlmutter, A.J. Smallridge, *Synthesis*, 1032 (1987).
160. J. Pomet, *J. Organometal. Chem.*, **340** 273 (1988).
161. J. Barluenga, M. Tomas, A. Ballesteros, V. Gotor, J. C. S., *Chem. Commun.*, 1195 (1987).
162. P. Cros, C. Triantaphylides, G. Buono, *J. Org. Chem.*, **53** 185 (1988).
163. R.V. Williams, C.L.A. Sung, J. C. S., *Chem. Commun.*, 590 (1987).
164. H. Okinoshima, *Jpn. Kokai Tokkyo Koho JP 61,207,389 [86,207,389] (C1. C07F7/08)* (1986). *Chem. Abstr.*, **108**:150710u.
165. H. Sakurai, K. Ebata, C. Kabuto, Y. Nakadaira, *Chem. Lett.*, 301 (1987).
166. S. Martin, R. Sauvetre, J.F. Normant, *Bull. Soc. Chim. Fr.*, 900 (1986).
167. A. Oliva, A. Molinari, *Synthetic Commun.*, **17** 837 (1987).
168. A.A. Kamyshova, V.I. Dostovalova, E.Ts. Chukovskaya, *Izv. Akad. Nauk SSSR, Ser. Khim.*, 1174 (1987). *Chem. Abstr.*, **108**:186812t.
169. G.Yu. Zhila, O.G. Yarosh, N.N. Vlasova, A.I. Albanov, M.G. Voronkov, *Zh. Obshch. Khim.*, **58** 536 (1988). *Chem. Abstr.*, **110**:23955u.
170. M.G. Voronkov, L.P. Petukhov, S.N. Adamovich, V.P. Baryshok, V.I. Rakhin, B.Z. Shterenberg, R.G. Mirskov, *Izv. Akad. Nauk SSSR, Ser. Khim.*, 204 (1987). *Chem. Abstr.*, **108**:37907a.
171. G.S. Zaitseva, L.I. Livantsova, O.P. Noviova, A.V. Kisin, *Zh. Obshch. Khim.*, **58** 714 (1988). *Chem. Abstr.*, **109**:230781d.
172. T. Kusumoto, T. Hiyama, *Tetrahedron Lett.*, **28** 1811 (1987).

173. E. Lukevics, L.I. Borisova, V.N. Gevorgyan, *Khim. Geterotsikl. Soedin*, **136** (1987).
Chem. Abstr., **108**:75469s.
174. V.A. Surnin, M.D. Stadnichuk, *Zh. Obshch. Khim.*, **57** 1303 (1987). *Chem. Abstr.*,
108:131907x.
175. N. Auner, *J. Organometal. Chem.*, **336** 59 (1987).
176. K. Wakamatsu, K. Oshima, K. Utimoto, *Chem. Lett.*, 2029 (1987).
177. E. Torres, G.L. Larson, G.J. McGarvey, *Tetrahedron Lett.*, **29** 1355 (1988).
178. S. Kuroda, T. Katsuki, M. Yamaguchi, *ibid.*, **28** 803 (1987).
179. K. Karabelas, A. Hallberg, *J. Org. Chem.*, **53** 4909 (1988).
180. Y. Hatanaka, T. Hiyama, *ibid.*, **53** 918 (1988).
181. O.N. Kolesnikova, L.I. Livantsova, Yu.M. Chupina, S.N. Shurov, G.S. Zaitseva, *Zh. Org. Khim.*, **24** 458 (1988). *Chem. Abstr.*, **109**:170153p.
182. P.J. Garratt, A. Tsotinis, *Tetrahedron Lett.*, **29** 1833 (1988).
183. D. Hermeling, H.J. Schaefer, *Chem. Ber.*, **121** 1151 (1988).
184. Y.T. Tao, M.L. Chen, *J. Org. Chem.*, **53** 69 (1988).
185. E.V. Vedejs, J.R. Pribish, *ibid.*, **53** 1593 (1988).
186. D.W. Hansen, Jr., R. Pappo, R.B. Garland, *ibid.*, **53** 4244 (1988).
187. S.E. Denmark, G.A. Hite, *Helv. Chim. Acta*, **71** 195 (1988).
188. S.E. Denmark, K.L. Habermas, G.A. Hite, *ibid.*, **71** 168 (1988).
189. T. Yamazaki, N. Ishikawa, *Bull. Soc. Chim. Fr.*, 937 (1986).
190. W.C. Joo, Y.C. Park, S.K. Kang, J.H. Hong, Y.K. Kong, *Bull. Korean Chem. Soc.*, **8** 270 (1987). *Chem. Abstr.*, **109**:93109z.
191. E.A. Cheryshev, S.A. Bashkirova, N.G. Komalenkova, D.A. Zagorets, G.N. Turkel'taub, V.M. Nosova, *Zh. Obshch. Khim.*, **57** 1419 (1987). *Chem. Abstr.*, **108**:221763b.
192. M.B. Kelly, J. Laane, *J. Phys. Chem.*, **92** 4056 (1988).
193. M. Grignon-Dubois, M. Laguere, *Organometallics.*, **7** 1443 (1988).
194. A.N. Egorochkin, M.A. Lopatin, S.E. Zhun, V.D. Sheludyakov, *Metalloorg. Khim.*, **1** 350 (1988). *Chem. Abstr.*, **110**:23959.
195. R. Muenstedt, U. Wannagat, *J. Organometal. Chem.*, **322** 11 (1987).

196. H. Abdul, M.A. Sheat, J.M.A. Al-Rawi, Z.S. Salih, *J. Chem. Res. Synop.*, **184** (1987).
197. T. Liese, A. De Meijere, *Chem. Ber.*, **119** 2995 (1986).
198. E.T. Bogoradovskii, N.V. Girbasova, V.S. Zavgorodnii, A.A. Petrov, *Zh. Obshch. Khim.*, **56** 2801 (1986). *Chem. Abstr.*, **108**:6120j.
199. J.W. Tilley, S. Zawoiski, *J. Org. Chem.*, **53** 386 (1988).
200. T. X. Neenan, G.M. Whitesides, *Ibid.*, **53** 2489 (1988).
201. K.A. Horn, R.B. Grossman, A.A. Whitenack, *J. Organometal. Chem.*, **332** 271 (1987).
202. M.G. Voronkov, O.G. Yarosh, G.Yu. Turkina, V.Yu. Vitovskii, *Zh. Obshch. Khim.*, **57** 2150 (1987). *Chem. Abstr.*, **109**:93123z.
203. M.G. Voronkov, Yu. E. Ovchinnikov, V.E. Shklover, Yu.T. Struchkov, O.G. Yarosh, G.Yu. Turkina, V.Yu. Vitovskii, *Dokl. Akad. Nauk SSSR* 296 (1987). *Chem. Abstr.*, **109**:93118b.
204. Y. Shen, Q. Liao, *Synthesis*, 321 (1988).
205. N.G. Kundu, B. Das, A. Majumdar, L.N. Choudhuri, *Tetrahedron Lett.*, **28** 5543 (1987).
206. S. Fukuoka, H. Nanri, T. Katsuki, M. Yamaguchi, *Ibid.*, **28** 6205 (1987).
207. M. Hayashi, A. Inubushi, T. Mukaiyama, *Chem. Lett.* 1975 (1987).
208. T. Kitamura, P.J. Stang, *J. Org. Chem.*, **53** 4105 (1988).
209. A.I. Borisova, A.S. Medvedeva, I.D. Kalikhman, N.S. Vyasankin, *Izv. Akad. Nauk SSSR, Ser. Khim.*, 1866 (1987).
210. S.C. Shim, T.S. Lee, *J. Org. Chem.*, **53** 2410 (1988).
211. P. Hong, T. Mise, H. Yamazaki, *J. Organometal. Chem.*, **334** 129 (1987).
212. K. Tetsuo, H. Tamejiri, *Tetrahedron Lett.*, **28** 1807 (1987).
213. T. Sakamoto, Y. Kondo, S. Iwashita, T. Nagano, H. Yamanaka, *Chem. Pharm. Bull.* **36** 1305 (1988).
214. T. Sakamoto, Y. Kondo, S. Iwashita, H. Yamanaka, *Ibid.*, **35** 1823 (1987).
215. K. Matsumoto, T. Uchida, Y. Ikemi, T. Tanaka, M. Asahi, T. Kato, H. Konishi, *Bull. Chem. Soc. Jpn.*, **60** 3645 (1987).
216. D. Crich, S.M. Fortt, *Tetrahedron Lett.*, **28** 2895 (1987).

217. M.A. Boaventura, J. Drouin, F. Theobald, N. Rodier, *Bull. Soc. Chim., Fr.*, 1006 (1987).
218. A.S. Kende, P. Hebeisen, R.C. Newbold, *J. Am. Chem. Soc.*, **110** 3315 (1988).
219. G.A. Peterson, F.A. Kunng, J.S. McCallum, W.D. Wulff, *Tetrahedron Lett.*, **28** 1381 (1987).
220. K. Iritani, N. Yanagihara, K. Utimoto, *J. Org. Chem.*, **51** 5499 (1986).
221. H. Sakata, I. Kuwajima, *Tetrahedron Lett.*, **28** 5719 (1987).
222. K. Kamienska-Trela, H. Ilcewicz, M. Rospenk, M. Pajdowska, L. Sobczyk, *J. Chem. Res., Synop.* 122 (1987).
223. N.I. Shergina, L.V. Sherstyannikova, O.G. Yarosh, L.V. Shchukina, M.G. Voronkov, *Izv. Akad. Nauk SSSR, Ser. Khim.*, 2709 (1986).
224. S. Wadman, R. Whitby, C. Yeates, P. Kocienski, K. Cooper, *J. C. S., Chem. Commun.*, 241 (1987).
225. K.K. Wang, S. Dhumrongvaraporn, *Tetrahedron Lett.*, **28** 1007 (1987).
226. K.K. Wang, K.E. Yang, *Ibid.*, **28** 1003 (1987).
227. C. Nativi, M. Taddei, *J. Org. Chem.*, **53** 820 (1988).
228. C. Nativi, A. Ricci, M. Taddei, *Tetrahedron Lett.*, **28** 2751 (1987).
229. C. Nativi, M. Taddei, *Ibid.*, **28** 347 (1987).
230. T. Hayashi, A. Yamamoto, T. Iwata, Y. Ito, *J. C. S., Chem. Commun.*, 398 (1987).
231. T. Hayashi, Y. Matsumoto, Y. Ito, *J. Am. Chem. Soc.*, **110** 5579 (1988).
232. J.R. Hwu, C. Lung, B. Liaw, *Ibid.*, **110** 7252 (1988).
233. K. Fugami, K. Oshima, K. Utimoto, H. Nozaki, *Bull. Chem. Soc. Jpn.*, **60** 2509 (1987).
234. G. Majetich, K. Hull, *Tetrahedron*, **43** 5621 (1987).
235. E.J. Corey, R.M. Burke, *Tetrahedron Lett.*, **28** 6413 (1987).
236. B.M. Trost, M. Buch, M.L. Miller, *J. Org. Chem.*, **53** 4887 (1988).
237. T.K. Sarkar, S.K. Ghosh, *Tetrahedron Lett.*, **28** 2061 (1987).
238. H. Sakurai, S. Kyushin, Y. Nakadaira, *Chem. Lett.*, 297 (1987).
239. M. Arimoto, H. Yamaguchi, E. Fujita, M. Ochiai, Y. Nagao, *Tetrahedron Lett.*, **28** 6289 (1987).

240. A.T. Russell, G. Procter, *ibid.*, **28** 2045 (1987).
241. A.T. Russell, G. Procter, *ibid.*, **28** 2041 (1987).
242. I. Fleming, A. Sarkar, A.P. Thomas, J. C. S., Chem. Commun., 157(1987).
243. G. Cerveau, C. Chuit, R.J.P. Corriu, C. Reye, J. Organometal. Chem., **328** C17 (1987).
244. M. Kira, K. Sato, H. Sakurai, J. Am. Chem. Soc., **110** 4599 (1988).
245. M. Kiro, M. Kobayashi, H. Sakurai, Tetrahedron Lett., **28** 4081 (1987).
246. J.S. Panek, M.A. Sparks, *ibid.*, **28** 4649 (1987).
247. M. Bellassoued, R. Ennigrou, M. Gaudemar, J. Organometal. Chem., **338** 149 (1988).
248. G. Majetich, J. Defauw, C. Ringold, J. Org. Chem., **53** 50 (1988).
249. T. Asada, M. Tsukamoto, H. Iio, T. Tokoroyama, Tennen Yuki Kagobutsu Toronkai Koen Yoshishu, 377 (1986). Chem. Abstr., **108**:132092q.
250. T. Tokoroyama, M. Tsukamoto, T. Asada, H. Iio, Tetrahedron Lett., **28** 6645 (1987).
251. K. Nickisch, H. Laurent, *ibid.*, **29** 1533 (1988).
252. M. Hayashi, T. Mukaiyama, Chem. Lett., 289 (1987).
253. I. Fleming, N.D. Kindon, Tetrahedron Lett., **28** 5921 (1987).
254. T. Kunz, H.U. Reissig, Angew. Chem., **100** 297 (1988).
255. L. Coppi, A. Mordini, M. Taddei, Tetrahedron Lett., **28** 969 (1987).
256. Z.Y. Wei, J.S. Li, T.H. Chan, *ibid.*, **28** 3441 (1987).
257. M. Asaoka, H. Takei, *ibid.*, **28** 6343 (1987).
258. R.D. Walup, N.U. Obeyesekere, Synthesis, 607 (1987).
259. T. Kaempchen, G. Moddelmog, D. Schultz, G. Seitz, Liebigs Ann. Chem., 855 (1988).
260. R.G. Andrew, R.E. Conrow, J.D. Elliott, W.S. Johnson, S. Ramezani, Tetrahedron Lett., **28** 6535 (1987).
261. S. Kano, T. Yokomatsu, H. Iwasawa, S. Shibuya, Chem. Lett., 1531 (1987).
262. A. Mann, C. Nativi, M. Taddei, Tetrahedron Lett., **29** 3247 (1988).
263. T.V. Lee, R.J. Boucher, C.J.M. Rockell, *ibid.*, **29** 689 (1988).

264. C. Brueckner, H. Holzinger, H.U. Reissig, *J. Org. Chem.*, **53** 2450 (1988).
265. Y. Araki, N. Kobayashi, Y. Ishido, J. Nagasawa, *Carbohydr. Res.*, **171** 125 (1987).
266. T. Mukaiyama, M. Ohshima, N. Miyoshi, *Chem. Lett.*, 1121 (1987).
267. K. Hiroi, H. Sato, *Synthesis*, 811 (1987).
268. K. Hiroi, H. Sato, H. Sakurai, *Annu. Rep. Tohoku Coll. Pharm.*, **75** (1986). *Chem. Abstr.*, **109**:109943e.
269. T. Hayashi, Y. Matsumoto, Y. Ito, *Chem. Lett.*, 2037 (1987).
270. K. Soai, M. Ishizaki, *Pept. Chem.*, 327 (1986). *Chem. Abstr.*, **108**:38323u.
271. M. Ohno, S. Matsuoka, S. Eguchi, *Synthesis*, 1092 (1987).
272. P.A. Grieco, W.F. Fobare, J. C. S., *Chem. Commun.*, 185 (1987).
273. W.S. Johnson, C. Newtown, S.D. Lindell, *Tetrahedron Lett.*, **27** 6027 (1986).
274. T. Takeda, Y. Kaneko, H. Nakagawa, T. Fujiwara, *Chem. Lett.*, 1963 (1987).
275. X.Y. Xiao, S.K. Park, G.D. Prestwich, *J. Org. Chem.*, **53** 4869 (1988).
276. L. Wilczek, J.P. Kennedy, *Polym. Bull.*, **17** 37 (1987). *Chem. Abstr.*, **108**:37158g.
277. P.G.M. Wuts, Y.W. Jung, *J. Org. Chem.*, **53** 1957 (1988).
278. N. Ono, T.X. Jun, T. Hashimoto, A. Kaji, J. C. S., *Chem. Commun.*, 947 (1987).
279. Y. Hayashi, *Chem. Lett.*, 1811 (1987).
280. K. Lee, D.Y. Kim, D.Y. Oh, *Tetrahedron Lett.*, **29** 667 (1988).
281. Y. Otsuji, K. Mizuno, *Kenkyu Hokoku - Asahi Garasu Kogyo Gijutsu Shoreikai*, **49** 215 (1986), *Chem. Abstr.*, **108**:21086w.
282. D.G. Cleary, L.A. Paquette, *Synthetic Commun.*, **17** 497 (1987).
283. B.M. Trost, S.M. Mignani, T.N. Nanninga, *J. Am. Chem. Soc.*, **110** 1602 (1988).
284. B.M. Trost, M.L. Miller, *ibid.*, **110** 3687 (1988).
285. A. Hosomi, K. Hoashi, S. Kohra, Y. Tominaga, K. Otaka, H. Sakurai, J. C. S., *Chem. Commun.*, 570 (1987).
286. J. Yoshida, K. Sakaguchi, S. Nakatani, S. Isoe, *Stud. Org. Chem.*, **85** (1987). *Chem. Abstr.*, **108**:112111s.
287. Y. Inouye, S. Niwayama, T. Okada, H. Hiroshi, *Heterocycles*, **25** 109 (1987).

288. K. Saigo, K. Tateishi, H. Adachi, Y. Saotome, *J. Org. Chem.*, **53** 1572 (1988).
289. W. Adam, M. Schwarm, *Ibid.*, **53** 3129 (1988).
290. N. Shimizu, F. Shibata, S. Imazu, Y. Tsuno, *Chem. Lett.*, 1071 (1987).
291. K. Tamao, E. Nakajo, Y. Ito, *Synthetic Commun.*, **17** 1637 (1987).
292. H.H. Tso, T.S. Chou, W.C. Lee, J. C. S., *Chem. Commun.*, 934 (1987).
293. R.B. Bates, J.J. White, K.H. Schram, *Org. Mass Spectrom.*, **22** 295 (1987).
294. J. Pornet, L. Miginiac, *J. Organometal. Chem.*, **319** 333 (1987).
295. W.J. Klaver, M.J. Moolenaar, H. Hiemstra, W.N. Speckamp, *Tetrahedron*, **44** 3805 (1988).
296. H.H. Mooiweer, H. Hiemstra, H.P. Fortgens, W.N. Speckamp, *Tetrahedron Lett.*, **28** 3285 (1987).
297. D. Schinzer, G. Dettmer, M. Ruppelt, S. Solyom, J. Steffen, *J. Org. Chem.*, **53** 3823 (1988).
298. D. Damour, J. Pornet, L. Miginiac, *Tetrahedron Lett.*, **28** 4689 (1987).
299. R. Okazaki, M. Unno, N. Inamoto, *Chem. Lett.*, 2293 (1987).
300. E. Epifani, S. Florio, G. Ingrosso, *Tetrahedron*, **43** 1937 (1987).
301. O.S. Ackerman, F. Bickelhaupt, *J. Organometal. Chem.*, **338** 159 (1988).
302. H. Ishibashi, H. Nakatani, Y. Umei, W. Yamamoto, M. Ikeda, J. C. S., *Perkin Trans*, **1**, 589 (1987).
303. M. Bordeau, P. Villeneuve, B. Bennetau, J. Dunogues, *J. Organometal. Chem.*, **331** 169 (1987).
304. I.S. Arkrem, N.M. Chistovalova, D.V. Avetisyan, V.F. Sizoi, M.E. Vol'pin, *Izv. Akad. Nauk SSSR, Ser. Khim.*, 1868 (1987). *Chem. Abstr.*, **109**:128458s.
305. K. Mizuno, K. Terasaka, M. Yasueda, Y. Otsuji, *Chem. Lett.*, 145 (1988).
306. W.S. Trahanovsky, C.H. Chou, D.R. Fischer, B.C. Gerstein, *J. Am. Chem. Soc.*, **110** 6579 (1988).
307. S. Takano, S. Satoh, K. Ogasawara, *Heterocycles*, **26** 1483 (1987).
308. I.S. Cho, P.S. Mariano, *J. Org. Chem.*, **53** 1590 (1988).
309. G. Dai-Ho, P.S. Mariano, *Ibid.*, **53** 5113 (1988).

310. K. Ya. Burshtein, P.P. Shorygin, Dokl. Akad. Nauk SSSR **296** 903 (1987). Chem. Abstr., **108**:166707j.
311. R. Neidlein, D. Christen, V. Poignee, R. Boese, D. Blaeser, A. Gieren, C. Ruiz-Perez, T. Huebner, Angew. Chem., **100** 292 (1988).
312. J.S. Swenton, M. Platz, L.D. Venham, J. Org. Chem., **53** 2764 (1988).
313. A. Marfat, M.P. Carta, Synthesis, 515 (1987).
314. T.G. Back, M.V. Krishna, K.R. Muralidharan, Tetrahedron Lett., **28** 1737 (1987).
315. K. Tanaka, K. Minami, A. Kaji, Chem. Lett., 809 (1987).
316. Y. Guan, C. Hu, Gaodeng Xuexiao Huaxue Xuebao, **8** 905 (1987). Chem. Abstr., **109**:92366u.
317. H. Andringa, Y. Heus-Kloos, L. Brandsma, J. Organometal. Chem., **336** C41 (1987).
318. R.L. Linderman, A. Ghannam, J. Org. Chem., **53** 2878 (1988).
319. J.G. Lee, D.S. Ha, Synthesis, 318 (1988).
320. M.L. Christiansen, T. Benneche, K. Undheim, Acta Chem. Scand., Ser. B, **B41** 536 (1987).
321. N.S. Fedotov, E.V. Grishina, V.D. Sheludyakov, A.A. Bernadskii, V.N. Bochkarev, Zh. Obshch. Khim., **57** 959 (1987). Chem. Abstr., **108**:75473p.
322. M.G. Voronkov, S.V. Kirpichenko, A.T. Abrosimova, A.I. Albanov, V.V. Keiko, V.I. Lavrent'ev, J. Organometal. Chem., **326** 159 (1987).
323. N. Imai, K. Achiwa, Chem. Pharm. Bull., **35** 593 (1987).
324. T. Takiguchi, T. Nonaka, Chem. Lett., 1217 (1987).
325. T. Koizumi, T. Fuchigami, T. Nonaka, Chem. Lett., 1095 (1987).
326. J. Yoshida, S. Isoe, Chem. Lett., 631 (1987).
327. H. Ishibashi, H. Nakatani, K. Maruyama, K. Minami, M. Ikeda, J. C. S., Chem. Commun., 1443 (1987).
328. H. Ishibashi, H. Nakatani, H. Sakashita, M. Ikeda, J. C. S., Chem. Commun., 338 (1987).
329. E. Hasagawa, W. Xu, P.S. Mariano, C. Ung, J.U. Kim, J. Am. Chem. Soc., **110** 8099 (1988).
330. T. Kawashima, T. Ishii, N. Inamoto, Bull. Chem. Soc. Jpn., **60** 1831 (1987).
331. S. Shimizu, M. Ogata, J. Org. Chem., **53** 5160 (1988).

332. A.R. Katritzky, S. Sengupta, *Tetrahedron Lett.*, **28** 5419 (1987).
333. S.V. Kessar, P. Singh, D. Venugopal, *Indian J. Chem., Sect. B* **26B** 605 (1987).
334. A. Hosomi, S. Hayashi, K. Hoashi, S. Kohra, Y. Tominaga, *J. C. S., Chem. Commun.*, 1442 (1987).
335. R. Cunico, K.S. Chu, *Synthetic Commun.*, **17** 271 (1987).
336. Y. Terao, N. Imai, K. Achiwa, *Chem. Pharm. Bull.*, **35** 1596 (1987).
337. N. Imai, K. Achiwa, *Ibid.*, **35** 2646 (1987).
338. D. Doepp, G. Rehmer, H. Brueggemann, *Chem. Ber.*, **121** 1651 (1988).
339. N. Shirai, F. Sumiya, Y. Sato, M. Hori, *J. C. S., Chem. Commun.*, 370 (1988).
340. M. Aono, Y. Terao, K. Achiwa, *Chem. Lett.*, 1851 (1987).
341. Y. Terao, M. Aono, N. Imai, K. Achiwa, *Chem. Pharm. Bull.*, **35** 1734 (1987).
342. V.N. Gevorgyan, L.I. Borisova, O.A. Pudova, E. Lukevics, *Latv. PSR Zinat. Akad. Cestis, Kim. Ser.* 362 (1987). *Chem. Abstr.*, **1089**:6574f.
343. R. Matsuoka, Y. Horiguchi, I. Kuwajima, *Tetrahedron Lett.*, **28** 1299 (1987).
344. E. Block, A.J. Yencha, M. Aslam, V. Eswarakrishnan, J. Luo, A. Sano, *J. Am. Chem. Soc.*, **110** 4748 (1988).
345. A.A. Macharashvili, V.E. Shklover, Yu.T. Struchov, Yu.I. Baukov, E.P. Kramarova, G.I. Oleneva, *J. Organometal. Chem.*, **327** 167 (1987).
346. W. Hollstein, K. Harms, M. Marsch, G. Boche, *Angew. Chem.*, **99** 1279 (1987).
347. K. Tomioka, H. Kawasaki, K. Yasuda, K. Koga, *J. Am. Chem. Soc.*, **110** 3597 (1988).
348. B. Rempfer, G. Pfafferott, H. Oberhammer, H. Beckers, H. Buerger, R. Eujen, J.E. Boggs, *Rev. Chim. Miner.* **23** 551 (1986). *Chem. Abstr.*, **108**:75466p.
349. D.M. Wetzol, J.I. Brauman, *J. Am. Chem. Soc.*, **110** 8333 (1988).
350. S.J. Danishefsky, N. Mantlo, *Ibid.*, **110** 8129 (1988).
351. J.E. MacDonald, G.S. Poindexter, *Tetrahedron Lett.*, **28** 1851 (1987).
352. T. Hiiro, N. Kambe, A. Ogawa, N. Miyoshi, S. Murai, N. Sonoda, *Angew. Chem.*, **99** 1221 (1987).
353. T. Cohen, S. H. Jung, M.L. Romberger, D.W. McCullough, *Tetrahedron Lett.*, **29** 25 (1988).
354. S. Harvey, P.C. Junk, C.L. Raston, G. Salem, *J. Org. Chem.*, **53** 3134 (1988).

355. G. Bartoli, M. Bosco, R. Dalpozzo, P.E. Todesco, J. C. S., Chem. Commun., 807 (1988).
356. E. Negishi, K. Akiyoshi, J. Am. Chem. Soc., 110 646 (1988).
357. P.T. Meinke, G.A. Krafft, A. Guram, J. Org. Chem., 53 3632 (1988).
358. T. Cohen, M. Nyers, *Ibid.*, 53 457 (1988).
359. J. Otera, Y. Niibo, H. Aikawa, Tetrahedron Lett., 28 2147 (1987).
360. A.R. Katritzky, S. Sengupta, *Ibid.*, 28 1847 (1987).
361. T. Shioiri, Y. Iwamoto, T. Aoyama, Heterocycles, 26 1467 (1987).
362. P. Savignac, M.P. Teulede, N. Collignon, J. Organometal. Chem., 323 135 (1987).
363. A. Fuestner, *Ibid.*, 336 C33 (1987).
364. S. Inoue, Y. Sato, T. Suzuki, Organometallics., 7 739 (1988).
365. B.B. Snider, R.B. Beal, J. Org. Chem., 53 4508 (1988).
366. D. Spitzner, T. Zaubitzer, Y.J. Shi, E. Wenkert, J. Org. Chem., 53 2274 (1988).
367. M. Borth, K.D. Bowles, L. Schicksupp, N.R. Natale, J. Organometal. Chem., 331 1 (1987).
368. M.T. Reetz, J. Rheinheimer, J. Org. Chem., 51 5465 (1986).
369. A. Tzschach, W. Uhlig, U. Thust, DD 247,005 (C1. C07F7/18) (1987). Chem. Abstr., 108:112733w.
370. T. Aoyama, T. Shioiri, Synthesis, 228 (1988).
371. G. Pattenden, S.J. Teague, Tetrahedron, 43 5637 (1987).
372. T. Hirao, T. Masunaga, K. Hayashi, Y. Ohshiro, Nippon Kagaku Kaishi 1277 (1987). Chem. Abstr., 108:94084d.
373. M.B. Anderson, M.G. Ranasinghe, J.T. Palmer, P.L. Fuchs, J. Org. Chem., 53 3125 (1988).
374. J.T. Palmer, P.L. Fuchs, Synthetic Commun., 18 233 (1988).
375. C.N. Hsiao, H. Schechter, J. Org. Chem., 53 2688 (1988).
376. M.D. Jones, R.D.W. Kemmitt, Appl. Organomet. Chem., 1 281 (1987).
377. R. Taylor, J. C. S., Chem. Commun., 741 (1987).
378. C. Blankenship, G.J. Wells, L.A. Paquette, Tetrahedron, 44 4023 (1988).

379. E.N. Fedorenko, L.I. Livantsova, G.S. Zaitseva, Yu.I. Baukov, A.V. Kisin, V.M. Nosova, Zh. Obshch. Khim., **57** 1673 (1987).
380. G.S. Zaitseva, L.I. Livantsova, E.N. Fedorenko, A.V. Kisin, A.G. Shipov, Yu.I. Baukov, *Ibid.*, **58** 712 (1988).
381. G.A. Artamkina, S.V. Kovalenko, I.P. Beleskaya, O.A. Reutov, J. Organometal. Chem., **329** 139 (1987).
382. M. Asaoka, K. Takenouchi, H. Takei, Tetrahedron Lett., **29** 325 (1988).
383. M. Asaoka, K. Shima, H. Takei, *Ibid.*, **28** 5669 (1987).
384. H. Iio, T. Mizobuchi, T. Tokoroyama, *Ibid.*, **28** 2379 (1987).
385. T.J. Barton, M. H. Yeh, *Ibid.*, **28** 6421 (1987).
386. D.C. Snyder, J. Organometal. Chem., **320** 163 (1987).
387. R. Damrauer, W.P. Weber, G. Manuel, Chem. Lett., 235 (1987).
388. Yu.A. Sokolova, O.A. D'yachenko, L.O. Atovmyan, V.M. Berestovitskaya, E.V. Trukhin, G.A. Berkova, Izv. Akad. Nauk SSSR, Ser. Khim., 1773 (1987).
389. J.B. Lambert, G.T. Wang, R.B. Finzel, D.H. Teramura, J. Am. Chem. Soc., **109** 7838 (1987).
390. R.Kh. Freidlina, N.V. Blinova, M.A. Galkina, V.I. Dostovalova, E.Ts. Chukovskaya, Zh. Obshch. Khim., **57** 2541 (1987). Chem. Abstr., **109**:211123z.
391. K. Uchida, A. Nagata, A. Iyoda, Jpn. Kokai Tokkyo Koho JP 62,294,690 [87,294,690] (Cl. C07F7/08).
392. P.E. Eaton, H. Higuchi, R. Millikan, Tetrahedron Lett., **28** 1055 (1987).
393. I. Fleming, N.L. Reddy, K. Takai, A.C. Ware, J. C. S., Chem. Commun., 1472 (1987).
394. L. Coppi, A. Ricci, M. Taddei, Tetrahedron Lett., **28** 965 (1987).
395. M. Asaoka, K. Shima, H. Takei, J. C. S., Chem. Commun., 430 (1988).
396. J.R. Hwu, B.A. Gilbert, J. Organometal. Chem., **332** 53 (1987).
397. M.W. Ensinger, V.J. Shiner, Jr., Stud. Org. Chem., (Amsterdam) **31** (1987). Chem. Abstr., **109**:110490m.
398. K. Tanino, Y. Hatanaka, I. Kuwajima, Chem. Lett., 385 (1987).
399. Y.S. Lee, L. Del Valle, G.L. Larson, Synthetic Commun., **17** 385 (1987).
400. M. Ashwell, R.F.W. Jackson, J. C. S., Chem. Commun., 645 (1988).

401. N. Krause, D. Seebach, *Chem. Ber.*, **121** 1315 (1988).
402. A. Alexakis, D. Jachiet, *Tetrahedron Lett.*, **29** 217 (1988).
403. S. Okamoto, T. Shimazaki, Y. Kobayashi, F. Sato, *Ibid.*, **28** 2033 (1987).
404. R.J. Linderman, Y. Suhr, *J. Org. Chem.*, **53** 1569 (1988).
405. A. Capperucci, A. Degl'Innocenti, C. Faggi, A. Ricci, P. Dembech, G. Seconi, *Ibid.*, **53** 3612 (1988).
406. M.T. Rahman, M.T. Hassain, S.K. Nahar, A. Saha, *J. Indian Chem. Soc.*, **64** 31 (1987).
407. J. Kang, J.H. Lee, K.S. Kim, J.U. Jeong, *Tetrahedron Lett.*, **28** 3261 (1987).
408. Y. Ito, T. Matsuura, M. Murakami, *J. Am. Chem. Soc.*, **109** 7888 (1987).
409. M. Murakami, H. Ito, Y. Ito, *J. Org. Chem.*, **53** 4158 (1988).
410. F.H. Elsner, H.G. Woo, T.D. Tilley, *J. Am. Chem. Soc.*, **110** 313 (1988).
411. E.N. Step, V.F. Tarasov, A.L. Buchachenko, V.I. Ustinov, V.A. Grinenko, *Izv. Akad. Nauk SSSR, Ser. Khim.*, 200 (1988).
412. B.B. Wright, *J. Am. Chem. Soc.*, **110** 4456 (1988).
413. A. Ricci, A. Degl'Innocenti, G. Borselli, G. Reginato, *Tetrahedron Lett.*, **28** 4093 (1987).
414. A. Degl'Innocenti, A. Ricci, A. Mordini, G. Reginato, V. Colotta, *Gazz. Chim. Ital.*, **117** 645 (1987).
415. P.C. Bulman Page, S. Rosenthal, R.V. Williams, *Tetrahedron Lett.*, **28** 4455 (1987).
416. M. Nakada, Y. Urano, S. Kobayashi, M. Ohno, *J. Am. Chem. Soc.*, **110** 4826 (1988).
417. B.F. Bonini, A. Lenzi, G. Maccagnani, G. Barbaro, P. Giorgianni, D. Macciantelli, *J. C. S., Perkin Trans, 1*, 2643 (1987).
418. P. Carisi, G. Mazzanti, P. Zani, G. Barbaro, A. Battaglia, P. Giorgianni, *Ibid.*, 2647 (1987).
419. B.F. Bonini, G. Mazzanti, P. Zani, G. Maccagnani, *J. C. S., Chem. Commun.*, 365 (1988).
420. Y. Ito, S. Nishimura, M. Ishikawa, *Tetrahedron Lett.*, **28** 1293 (1987).
421. Y. Ito, T. Matsuura, M. Murakami, *J. Am. Chem. Soc.*, **110** 3692 (1988).
422. N. Inoue, K. Mochida, Y. Sakaguchi, H. Hayashi, *Chem. Phys. Lett.*, **143** 230 (1988).

423. E.B. Nadler, Z. Rappoport, D. Arit, Y. Apeloig, *J. Am. Chem. Soc.*, **109** 7873 (1987).
424. M.B. Coolidge, W.T. Borden, *J. Am. Chem. Soc.*, **110** 2298 (1988).
425. R.A. Jackson, C.J. Rhodes, *J. Organometal. Chem.*, **336** 45 (1987).
426. S.A. Barker, R.N. Haszeldine, P.J. Robinson, *J. C. S., Perkin Trans. 2*, 1861 (1987).
427. I. Safarik, A. Jodhan, O.P. Strausz, T.N. Bell, *Chem. Phys. Lett.*, **142** 115 (1987).
428. J.J. O'Brien, G.H. Atkinson, *J. Phys. Chem.*, **92** 5782 (1988).
429. I.V. Ovchinnikov, A.V. Golovkin, N.G. Komalenkova, E.A. Chernyshev, V.S. Nikitin, *Izv. Akad. Nauk SSSR, Ser. Khim.*, **57** 1421 (1987).
430. K. Oka, R. Nakao, Y. Nagata, T. Dohmaru, *J. C. S., Perkin Trans. 2*, 337 (1987).
431. S. Wu, G. Wu, F. Tao, Z. Lin, *Huaxue Xuebo*, **45** 1107 (1987). *Chem. Abstr.*, **109**:190474x.
432. K.M. Welsh, J. Michl, R. West, *J. Am. Chem. Soc.*, **110** 6689 (1988).
433. M.J. Fink, D.B. Puranik, *Organometallics.*, **6** 1809 (1987).
434. M.J. Fink, D.B. Dhananjay, M.P. Johnson, *ibid.*, **110** 1315 (1988).
435. W. Ando, M. Fujita, H. Yoshida, A. Sekiguchi, *ibid.*, **110** 3310 (1988).
436. D. Wong, T.H. Chan, *Can. J. Chem.*, **65** 2727 (1987).
437. C.A. Arrington, J.T. Petty, S.E. Payne, W.C.K. Haskins, *J. Am. Chem. Soc.*, **110** 6240 (1988).
438. M.A. Pearsall, R. West, *ibid.*, **110** 7228 (1988).
439. T. Akasaka, S. Nagase, A. Yabe, W. Ando, *ibid.*, **110** 6270 (1988).
440. A. Sekiguchi, K. Hagiwara, W. Ando, *Chem. Lett.*, 209 (1987).
441. G. Levin, P.K. Das, C.L. Lee, *Organometallics.*, **7** 1231 (1988).
442. H. Shizuka, H. Tanaka, K. Tonokura, K. Murata, H. Hiratsuka, J. Ohshita, M. Ishikawa, *Chem. Phys. Lett.*, **143** 225 (1988).
443. A. Tachibana, H. Fueno, M. Koizumi, T. Yamabe, K. Fuklui, *J. Phys. Chem.*, **92** 935 (1988).
444. R. Walsh, *Organometallics.*, **7** 75 (1988).
445. H.E. O'Neal, M.A. Ring, *ibid.*, **7** 1017 (1988).
446. M.E. Lee, J.K. Lee, C.H. Kim, *Bull. Korean Chem. Soc.*, **8** 355 (1987).

447. N. Auner, *J. Organometal. Chem.*, **336** 83 (1987).
448. D. Terunuma, M. Nakamura, E. Miyazawa, H. Nohira, *Bull. Chem. Soc. Jpn.*, **60** 2263 (1987).
449. S. Bain, S. Ijadi-Maghsoodi, T.J. Barton, *J. Am. Chem. Soc.*, **110** 2611 (1988).
450. H. Richter, S. Arenz, G. Michels, J. Schneider, O. Wagner, M. Regitz, *Chem. Ber.*, **121** 1363 (1988).
451. R.T. Contin, M. Namavari, *J. Am. Chem. Soc.*, **110** 3689 (1988).
452. N. Wiberg, G. Preiner, K. Schurz, *Chem. Ber.*, **121** 1407 (1988).
453. A.G. Brook, X. Vorspö, R.B. Ford, M. Hesse, W.J. Chatterton, *Organometallics*, **6** 2128 (1987).
454. G. Maas, K. Schneider, W. Ando, *J. C. S., Chem. Commun.*, **72** (1988).
455. N. Wiberg, G. Preiner, G. Wagner, H. Knoepf, G. Fischer, *Z. Naturforsch., B: Chem. Sci.*, **42** 1055 (1987).
456. N. Wiberg, G. Preiner, G. Wagner, H. Knoepf, *Z. Naturforsch., B: Chem. Sci.*, **42** 1062 (1987).
457. A.G. Brook, Y.X. Xong, A.X. Saxena, J.F. Sawyer, *Organometallics*, **7** 2245 (1988).
458. S. Koseki, M.S. Gordon, *J. Phys. Chem.*, **92** 364 (1988).
459. S.K. Shin, K.K. Irkura, J.L. Beauchamp, W.A. Goddard, III., *J. Am. Chem. Soc.*, **110** 24 (1988).
460. R.S. Grev, G.E. Scuseria, A.C. Scheiner, H.F. Schafer, III., M.S. Gordon, *Ibid.*, **110** 7337 (1988).
461. K. Takeuchi, N. Fukawa, M. Kato, M. Goto, Y. Nagai, *Chem. Lett.*, 1341 (1987).
462. H.B. Yokelson, A.J. Millevolte, K.J. Haller, R. West, *J. C. S., Chem. Commun.*, 1605 (1987).
463. E.A. Chernyshev, N.A. Mudrova, T.L. Krasnova, T.N. Tarasova, A.E. Chernyshev, *Zh. Obshch. Khim.*, **57** 1275 (1987).
464. E.A. Chernyshev, T.L. Krasnova, N.A. Mudrova, A.V. Golovkin, M.G. Kuznetsova, *Ibid.*, **57** 1725 (1987).
465. E.A. Chernyshev, N.A. Mudrova, T.L. Krasnova, A.B. Petrunin, *Ibid.*, **58** 716 (1988).
466. A. Baceiredo, C.D. Juengst, G. Manuel, W.P. Weber, *Chem. Lett.*, 237 (1987).
467. H. Sakurai, K. Sakamoto, M. Kira, *Ibid.*, 1075 (1987).

468. P. George, C.W. Bock, M. Trachtman, *Theor. Chim. Acta*, **71** 289 (1987).
469. K. Baldrige, M.S. Gordon, *J. Am. Chem. Soc.*, **110** 4204 (1988).
470. K.K. Baldrige, M.S. Gordon, *Organometallics.*, **7** 144 (1988).
471. K.M. Welsh, J.D. Rich, R. West, J. Michl, *J. Organometal. Chem.*, **325** 105 (1987).
472. A. Sekiguchi, G.R. Gillette, R. West, *Organometallics.*, **7** 1226 (1988).
473. G. Maerkl, W. Schlosser, *Angew. Chem.*, **100** 1009 (1988).
474. Y. Apeloig, *Stud. Org. Chem. (Amsterdam)* **31** 33 (1987). *Chem. Abstr.*, **109**:54822g.
475. D.N. Kevill, *J. Chem. Res., Synop.*, 272 (1987).
476. J.B. Lambert, W.J. Schulz, Jr., J.A. McConnell, W. Schilif, *J. Am. Chem. Soc.*, **110** 2201 (1988).
477. J.B. Lambert, W. Schilif, *ibid.*, **110** 6364 (1988).
478. S. Wlodek, D.K. Bohma, *ibid.*, **110** 2396 (1988).
479. A. Rajca, A. Streitweiser, *Organometallics.*, **7** 2215 (1988).
480. J. Chmielecka, J. Chojnowski, C. Eaborn, W.A. Stanczyk, *J. C. S., Chem. Commun.*, 1337 (1987).
481. M.H. Lien, A.C. Hopkinson, *J. Org. Chem.*, **53** 2150 (1988).
482. R. Damrauer, C.H. DePuy, S.E. Barlow, S. Gronert, *J. Am. Chem. Soc.*, **110** 2005 (1988).
483. W. Ando, K. Hagiwara, A. Sekiguchi, *Organometallics.*, **6** 2270 (1987).