

JOM 23682

# Trinuclear and tetranuclear iron/ruthenium carbonyl clusters stabilized by bridging selenium ligands

Pradeep Mathur, Md. Munkir Hossain and Raad S. Rashid

Chemistry Department, Indian Institute of Technology, Powai, Bombay 400 076 (India)

(Received February 10, 1993)

## Abstract

At room temperature,  $\text{Fe}_2(\text{CO})_6(\mu\text{-Se}_2)$  reacts with  $\text{Ru}_3(\text{CO})_{12}$  to form  $\text{Fe}_2\text{Ru}_3(\text{CO})_{17}(\mu_4\text{-Se})(\mu_3\text{-Se})$ , and with  $\text{Ru}(\text{CO})_4(\text{C}_2\text{H}_4)$  to form  $\text{Fe}_2\text{Ru}(\text{CO})_9(\mu_3\text{-Se})_2$ . The latter reacts with  $\text{Fe}(\text{CO})_5$  under visible light irradiation to give  $\text{Fe}_3\text{Ru}(\text{CO})_{11}(\mu_4\text{-Se})_2$ , and with  $\text{Ru}(\text{CO})_4(\text{C}_2\text{H}_4)$  to form  $\text{Fe}_2\text{Ru}_2(\text{CO})_{11}(\mu_4\text{-Se})_2$ . Visible light irradiation of a solution containing  $\text{Fe}_3(\text{CO})_9(\mu_3\text{-Se})_2$  and  $\text{Fe}(\text{CO})_5$  yields  $\text{Fe}_4(\text{CO})_{11}(\mu_4\text{-Se})_2$ . A solution containing  $\text{Fe}_3(\text{CO})_9(\mu_3\text{-Se})_2$  and  $\text{Ru}(\text{CO})_4(\text{C}_2\text{H}_4)$  at room temperature with stirring yielded  $\text{Fe}_3\text{Ru}(\text{CO})_{11}(\mu_4\text{-Se})_2$ .

## 1. Introduction

The use of elements of Group 16 of the Periodic Table as single atom ligands for cluster growth and stabilization of the metal core is now well established [1]. In recent years, the increased use of tellurium for this purpose has indicated that differences exist in the behaviour of Te-bridged clusters from those containing bridging S atoms [2]. There is an increasing interest in the use of Se-bridged clusters. The synthesis of  $\text{Ru}_4(\text{CO})_{11}(\mu_4\text{-Se})_2$  and  $\text{Ru}_3(\text{CO})_9(\mu_3\text{-Se})_2$  has been described and their reactivity towards monodentate and bidentate phosphine ligands as well as triphenylantimony has been investigated [3]. The activation of phenylacetylene on  $\text{Fe}_2(\text{CO})_6(\mu\text{-Se}_2)$  and the structural characterization of a mixed-metal selenium-bridged complex in which phenylacetylene bridges a  $\text{Fe}_2(\text{CO})_6\text{Se}_2$  moiety and a  $\text{Pt}(\text{PPh}_3)_2$  moiety has also been reported [4]. In continuation of our interest in developing facile methods of synthesis of clusters of desired composition, here we describe the synthesis and characterization of trinuclear and tetranuclear Se-bridged clusters of iron and ruthenium carbonyl (Scheme 1).

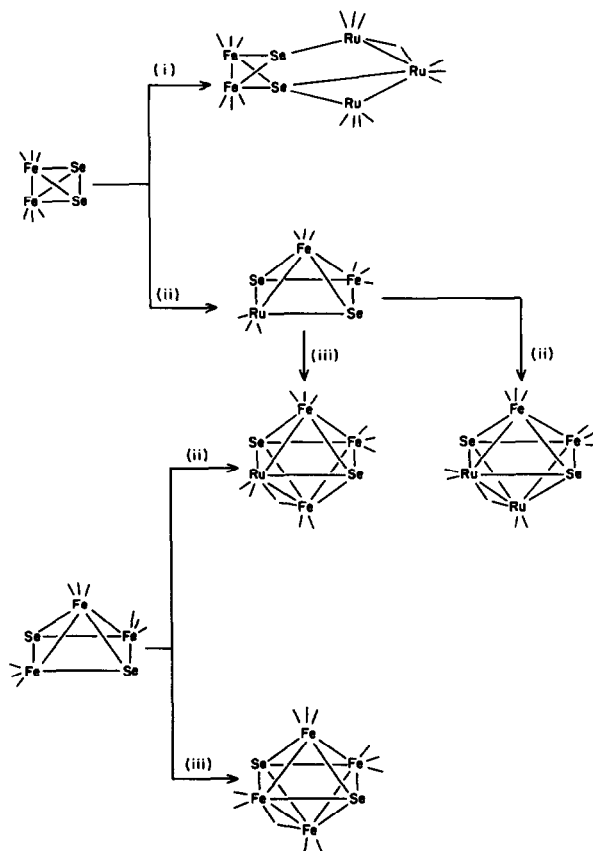
Scheme 1. (i)  $\text{Ru}_3(\text{CO})_{12}$ ; (ii)  $\text{Ru}(\text{CO})_4(\text{C}_2\text{H}_4)$ ; (iii)  $\text{Fe}(\text{CO})_5$ .

Correspondence to: Dr. P. Mathur.

## 2. Results and discussion

When a benzene solution containing  $\text{Fe}_2(\text{CO})_6(\mu\text{-Se}_2)$  and  $\text{Ru}_3(\text{CO})_{12}$  was stirred at room temperature for 10 h, a new cluster,  $\text{Fe}_2\text{Ru}_3(\text{CO})_{17}(\mu_4\text{-Se})(\mu_3\text{-Se})$  was formed. It was identified by comparison of its carbonyl stretching frequency pattern in its infrared spectrum with that observed for the related and structurally characterized  $\text{Fe}_2\text{Ru}_3(\text{CO})_{17}(\mu_4\text{-Te})(\mu_3\text{-Te})$  (Table 1) [5]. Elemental analysis confirmed the molecular formula of  $\text{Fe}_2\text{Ru}_3(\text{CO})_{17}(\mu_4\text{-Se})(\mu_3\text{-Se})$  (Table 2). A FAB mass spectrometric analysis showed peaks centred at  $m/e$  1049, corresponding to the  $[\text{Fe}_2\text{Ru}_3(\text{CO})_{17}\text{Se}_2]^+$  ion, and a good fit was observed between the experimentally obtained and the computer simulated isotopic distribution pattern for the molecular ion (Fig. 1). Overall, the formation of  $\text{Fe}_2\text{Ru}_3(\text{CO})_{17}(\mu_4\text{-Se})(\mu_3\text{-Se})$  formally involves elimination of CO from  $\text{Ru}_3(\text{CO})_{12}$  to yield the reactive, coordinatively unsaturated " $\text{Ru}_3(\text{CO})_{11}$ " fragment and its addition across the Se-Se bond of  $\text{Fe}_2(\text{CO})_6(\mu\text{-Se}_2)$ .  $\text{Fe}_2\text{Ru}_3(\text{CO})_{17}(\mu_4\text{-Te})(\mu_3\text{-Te})$  and  $\text{Fe}_2\text{Os}_3(\text{CO})_{17}(\mu_4\text{-Te})(\mu_3\text{-Te})$  were previously reported to be stable in solution; however, on refluxing in benzene or on ultraviolet irradiation of their hexane solutions, atom transfer occurs, and  $\text{Ru}_3(\text{CO})_9(\mu_3\text{-Te})_2$  and  $\text{Os}_3(\text{CO})_9(\mu_3\text{-Te})_2$  are formed as the sole products [6], respectively. The selenium-bridged cluster behaves somewhat differently. Firstly,  $\text{Fe}_2\text{Ru}_3(\text{CO})_{17}(\mu_4\text{-Se})(\mu_3\text{-Se})$  is not as stable in solution as its Te-analogue; in solution it slowly forms two compounds,  $\text{Ru}_3(\text{CO})_9(\mu_3\text{-Se})_2$  and  $\text{Fe}_2\text{Ru}_2(\text{CO})_{11}(\mu_4\text{-Te})_2$ . The same two compounds are also obtained on thermolysis or photolysis of solution containing  $\text{Fe}_2\text{Ru}_3(\text{CO})_{17}(\mu_4\text{-Se})(\mu_3\text{-Se})$ .

Room temperature stirring of  $\text{Fe}_2(\text{CO})_6(\mu\text{-Se}_2)$  with  $\text{Ru}(\text{CO})_4(\text{C}_2\text{H}_4)$  in a benzene/hexane (50:50, v/v) solution for 0.5 h formed the mixed-metal cluster,

TABLE 1. Infrared carbonyl stretching frequencies

Compound	$\nu(\text{CO})$ ( $\text{cm}^{-1}$ )
$\text{Fe}_2\text{Ru}_3(\text{CO})_{17}(\mu_4\text{-Se})(\mu_3\text{-Se})^a$	2126w, 2079m, 2076m, 2056m, 2049sh, 2033w, 2024m, 1996m, 1985m
$\text{Fe}_2\text{Ru}(\text{CO})_9(\mu_3\text{-Se})_2^a$	2097w, 2078w, 2067s, 2055w, 2037vs, 2025w, 2014w, 2002m, 1968w
$\text{Fe}_3\text{Ru}(\text{CO})_{11}(\mu_4\text{-Se})_2^b$	2087w, 2045vs, 2034s, 2013w,sh, 1841w
$\text{Fe}_2\text{Ru}_2(\text{CO})_{11}(\mu_4\text{-Se})_2^b$	2090w, 2045vs, 2011m,sh, 2008m,sh, 1841m,sh, 1827w
$\text{Fe}_4(\text{CO})_{11}(\mu_4\text{-Se})_2^b$	2079w, 2037vs, 2017m,sh, 2000m,sh, 1842w, 1838w

<sup>a</sup> In hexane solvent. <sup>b</sup> In dichloromethane solvent.

TABLE 2. Elemental analysis and melting point data

Compound	C (%)		M.p. ( $^{\circ}\text{C}$ )
	Found	Calc.	
$\text{Fe}_2\text{Ru}_3(\text{CO})_{17}(\mu_4\text{-Se})(\mu_3\text{-Se})$	19.4	19.3	118(d)
$\text{Fe}_2\text{Ru}(\text{CO})_9(\mu_3\text{-Se})_2$	17.3	17.0	95-97
$\text{Fe}_3\text{Ru}(\text{CO})_{11}(\mu_4\text{-Se})_2$	17.5	17.9	105(d)
$\text{Fe}_2\text{Ru}_2(\text{CO})_{11}(\mu_4\text{-Se})_2$	17.0	17.3	111(d)
$\text{Fe}_4(\text{CO})_{11}(\mu_4\text{-Se})_2$	19.6	19.4	101(d)

$\text{Fe}_2\text{Ru}(\text{CO})_9(\mu_3\text{-Se})_2$ . It was characterized on the basis of infrared spectroscopy by comparison of its carbonyl stretching frequencies with those observed for  $\text{Fe}_2\text{Ru}(\text{CO})_9(\mu_3\text{-S})_2$  and  $\text{Fe}_2\text{Ru}(\text{CO})_9(\mu_3\text{-Te})_2$  [7]. Elemental analysis confirmed the molecular formula. The electron impact mass spectrum of  $\text{Fe}_2\text{Ru}(\text{CO})_9(\mu_3\text{-Se})_2$  showed molecular ion peaks centred at  $m/e$  623 and peaks at  $m/e$  595, 567, 539, 511, 483, 455, 427, 399 and 371, corresponding to the successive loss of 9 CO groups.

When  $\text{Fe}(\text{CO})_5$  was added to a hexane solution of  $\text{Fe}_2\text{Ru}(\text{CO})_9(\mu_3\text{-Se})_2$  and the solution was photolysed with visible light,  $\text{Fe}_3\text{Ru}(\text{CO})_{11}(\mu_4\text{-Se})_2$  was formed and characterized by infrared spectroscopy and mass spectrometry. Its carbonyl stretching pattern is similar to that of the recently reported  $\text{Fe}_3\text{Ru}(\text{CO})_{11}(\mu_4\text{-S})(\mu_4\text{-Te})$  [8],  $\text{Ru}_4(\text{CO})_{11}(\mu_4\text{-Se})_2$  [3],  $\text{Fe}_2\text{Ru}_2(\text{CO})_{11}(\mu_4\text{-Te})_2$  [7] and  $\text{Ru}_4(\text{CO})_{11}(\mu_4\text{-Te})_2$  [9]. The electron impact mass spectrum showed peaks centred at  $m/e$  707, corresponding to the  $(\text{M}^+ - \text{CO})$  ion and also peaks centred at  $m/e$  679, 651, 595, 567, 539, 511, 455 and 427, corresponding to fragments arising from the suc-

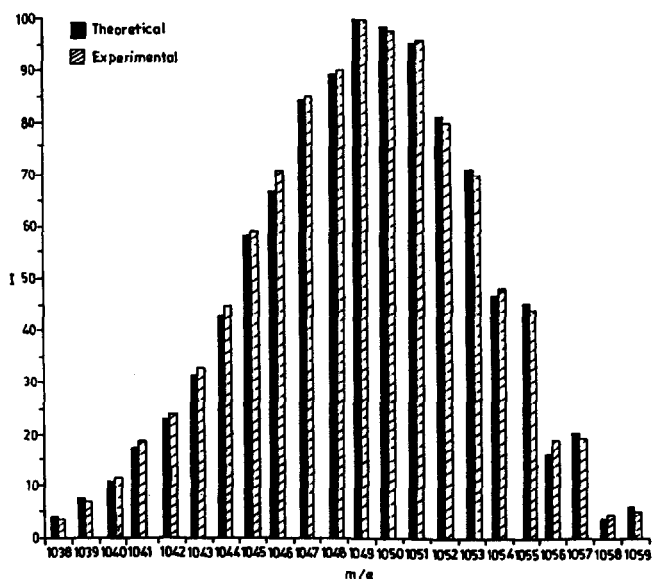

Fig. 1. Comparison of the experimental and computer simulated isotopic distribution pattern of the molecular ion ( $\text{M}^+$ ) of  $\text{Fe}_2\text{Ru}_3\text{Se}_2(\text{CO})_{17}$ .

cessive loss of all carbonyl groups. Elemental analysis confirmed the molecular formula of  $\text{Fe}_3\text{Ru}(\text{CO})_{11}(\mu_4\text{-Se})_2$ . The same cluster was also obtained when a hexane solution containing  $\text{Ru}(\text{CO})_4(\text{C}_2\text{H}_4)$  was added to a benzene/hexane (50:50, v/v) solution containing  $\text{Fe}_3(\text{CO})_9(\mu_3\text{-Se})_2$  and the mixture was stirred at room temperature.

The mixed-metal cluster  $\text{Fe}_2\text{Ru}_2(\text{CO})_{11}(\mu_4\text{-Se})_2$  was obtained when a hexane solution containing  $\text{Ru}(\text{CO})_4(\text{C}_2\text{H}_4)$  was added to a dichloromethane solution of  $\text{Fe}_2\text{Ru}(\text{CO})_9(\mu_3\text{-Se})_2$  and the mixture was stirred at room temperature. Its method of formation is similar to that of  $\text{Fe}_2\text{Ru}_2(\text{CO})_{11}(\mu_4\text{-Te})_2$ , which has been structurally characterized by single crystal X-ray diffraction methods [9]. Like all tetranuclear clusters of the form  $\text{M}_4(\text{CO})_{11}(\mu_4\text{-E})_2$ , where E = S, Se or Te,  $\text{Fe}_2\text{Ru}_2(\text{CO})_{11}(\mu_4\text{-Se})_2$  displays the characteristic carbonyl stretching pattern in its infrared spectrum, indicating that it too has the typical structure consisting of trapezoidal arrangement of the four metal atoms and the two selenium atoms quadruply bridging the opposite sides of the planar arrangement of the metal atoms. All such clusters which have been structurally characterized also reveal the common feature of a carbonyl group bridging the shortest edge of the metal trapezoid and semi-bridging carbonyls spanning across the edges adjacent to the shortest edge. In  $\text{Fe}_2\text{Ru}_2(\text{CO})_{11}(\mu_4\text{-Te})_2$ , it is the Ru–Ru edge which has the bridging carbonyl and the two Fe–Ru edges contain the semibridging carbonyls. A similar bridging carbonyl arrangement is probably to be found in  $\text{Fe}_2\text{Ru}_2(\text{CO})_{11}(\mu_4\text{-Se})_2$ .

Visible light irradiation under a fast nitrogen purge of a hexane solution containing  $\text{Fe}_3(\text{CO})_9(\mu_3\text{-Se})_2$  and  $\text{Fe}(\text{CO})_5$  afforded the tetranuclear cluster  $\text{Fe}_4(\text{CO})_{11}(\mu_4\text{-Se})_2$  which was characterized by infrared spectroscopy (a carbonyl stretching pattern typical of clusters of the form  $\text{M}_4(\text{CO})_{11}(\mu_4\text{-E})_2$  was observed). As expected on the basis of the electronegativity difference, the carbonyl stretching frequencies of  $\text{Fe}_4(\text{CO})_{11}(\mu_4\text{-Se})_2$  were found to be slightly lower than the corresponding frequencies observed in the spectrum of  $\text{Fe}_4(\text{CO})_{11}(\mu_4\text{-S})_2$  [10]. The electron impact mass spectrum showed peaks centred at  $m/e$  662, corresponding to the  $(\text{M}^+ - 1\text{CO})$  ion and peaks centred at  $m/e$  634, 606, 578, 550, 522, 494, 466, 438 and 410, corresponding to the successive loss of ten carbonyl groups. Although the previously reported  $\text{Fe}_4(\text{CO})_{11}(\mu_4\text{-S})_2$  is a stable cluster,  $\text{Fe}_4(\text{CO})_{11}(\mu_4\text{-Se})_2$  was found to convert to the trinuclear  $\text{Fe}_3(\text{CO})_9(\mu_3\text{-Se})_2$  in solution over a period of 1–2 days. A similar conversion has been observed for  $\text{Fe}_4(\text{CO})_{11}(\mu_4\text{-Te})_2$ , the conversion to  $\text{Fe}_3(\text{CO})_9(\mu_3\text{-Te})_2$  being more rapid than in the Se-containing cluster.

There are several reports in the literature on the synthesis of trinuclear and tetranuclear clusters which are stabilized by ligands derived from the main group elements [1]. The clusters described in this paper have been obtained under facile reaction conditions, and the mixed metal clusters represent the first examples of the clusters of the form  $\text{M}_2\text{M}'(\text{CO})_9(\mu_3\text{-Se})_2$  and  $\text{M}_{4-x}\text{M}'_x(\text{CO})_{11}(\mu_4\text{-Se})_2$  ( $\text{M} \neq \text{M}'$ ,  $x = 1, 2$ ).

### 3. Experimental details

All reactions were carried out under an atmosphere of argon using standard Schlenk techniques. All solvents were thoroughly dried and distilled immediately before use. Infrared spectra were recorded on a Nicolet 5DXB FTIR spectrometer as solutions in NaCl cells. Elemental analyses were performed on a Carlo Erba automatic analyser. Ultraviolet irradiations were carried out in a water-cooled double-walled quartz vessel. A 125-W immersion type mercury lamp manufactured by Applied Photophysics Ltd. was used. Visible irradiations were carried out by using a 40-W external light source. The compounds  $\text{Fe}_2(\text{CO})_6(\mu\text{-Se}_2)$  and  $\text{Fe}_3(\text{CO})_9(\mu_3\text{-Se})_2$  were prepared as reported previously [11].

#### 3.1. Preparation of $\text{Fe}_2\text{Ru}_3(\text{CO})_{17}(\mu_4\text{-Se})(\mu_3\text{-Se})$

Excess (three-fold)  $\text{Fe}_2(\text{CO})_6(\mu\text{-Se}_2)$  was stirred with  $\text{Ru}_3(\text{CO})_{12}$  (0.03 g, 0.05 mmol) in benzene solvent (20 ml) for 10 h. The solvent was removed under reduced pressure, and on chromatography of the residue on a silica gel column, using a dichloromethane/hexane (10:90, v/v) mixture as eluant, a single maroon band of  $\text{Fe}_2\text{Ru}_3(\text{CO})_{17}(\mu_4\text{-Se})(\mu_3\text{-Se})$  was obtained. Yield 0.018 g (36%).

At room temperature with stirring, a three-fold excess of  $\text{Fe}_2(\text{CO})_6(\mu\text{-Se}_2)$  and  $\text{Ru}_3(\text{CO})_{11}(\text{NCMe})$  in benzene solvent for 10 min resulted in almost quantitative formation of  $\text{Fe}_2\text{Ru}_3(\text{CO})_{17}(\mu_4\text{-Se})(\mu_3\text{-Se})$ .

#### 3.2. Preparation of $\text{Fe}_2\text{Ru}(\text{CO})_9(\mu_3\text{-Se})_2$

A hexane solution (120 ml) of  $\text{Ru}(\text{CO})_4(\text{C}_2\text{H}_4)$  (0.036 mmol) was prepared as described before. It was added to a benzene/hexane (50:50, v/v) solution (50 ml) of  $\text{Fe}_2(\text{CO})_6(\mu\text{-Se}_2)$  (0.036 mmol) and the mixture was stirred at room temperature for 0.5 h. The solvent was removed and the residue subjected to chromatographic work-up on a silica gel column using hexane as eluant. A purple band of  $\text{Fe}_2\text{Ru}(\text{CO})_9(\mu_3\text{-Se})_2$  was obtained as the sole product. Yield: 0.014 g (62%).

#### 3.3. Preparation of $\text{Fe}_3\text{Ru}(\text{CO})_{11}(\mu_4\text{-Se})_2$

Method (a): A hexane solution (120 ml) of  $\text{Ru}(\text{CO})_4(\text{C}_2\text{H}_4)$  (0.072 mmol) was obtained as de-

scribed before and added to a benzene/hexane (50:50, v/v) solution (100 ml) of  $\text{Fe}_3(\text{CO})_9(\mu_3\text{-Se})_2$  (0.041 g, 0.072 mmol). After stirring for 10 min, solvent was removed and the residue was placed on a silica gel column. Elution with a dichloromethane/hexane (25:75, v/v) mixture yielded a single, dark green band of  $\text{Fe}_3\text{Ru}(\text{CO})_{11}(\mu_4\text{-Se})_2$ . Yield: 0.007 g (34%).

Method (b): A hexane solution (50 ml) of  $\text{Fe}_2\text{Ru}(\text{CO})_9(\mu_3\text{-Se})_2$  (0.015 g, 0.025 mmol) and  $\text{Fe}(\text{CO})_5$  (0.2 ml, 0.04 mmol) was irradiated with visible light for 1.5 h. Dark green  $\text{Fe}_3\text{Ru}(\text{CO})_{11}(\mu_4\text{-Se})_2$  was isolated as described in method (a). Yield: 0.006 g (23%).

### 3.4. Preparation of $\text{Fe}_2\text{Ru}_2(\text{CO})_{11}(\mu_4\text{-Se})_2$

A hexane solution (120 ml) containing  $\text{Ru}(\text{CO})_4(\text{C}_2\text{H}_4)$  (0.075 mmol) was obtained as described before. It was added to a dichloromethane solution (50 ml) of  $\text{Fe}_2\text{Ru}(\text{CO})_9(\mu_3\text{-Se})_2$  (0.04 g, 0.075 mmol). After stirring the mixture for 0.5 h, the solvent was removed *in vacuo* and the residue was placed on a silica gel column. Elution with dichloromethane/hexane (20:80, v/v) as eluant separated trace amounts of  $\text{Ru}_3(\text{CO})_{12}$  and  $\text{Fe}_2\text{Ru}(\text{CO})_9(\mu_3\text{-Se})_2$  from the major brown band of  $\text{Fe}_2\text{Ru}_2(\text{CO})_{11}(\mu_4\text{-Se})_2$ . Yield: 0.011 g (23%).

### 3.5. Preparation of $\text{Fe}_4(\text{CO})_{11}(\mu_4\text{-Se})_2$

A hexane solution (80 ml) of a mixture of  $\text{Fe}_3(\text{CO})_9(\mu_3\text{-Se})_2$  (0.025 g, 0.04 mmol) and  $\text{Fe}(\text{CO})_5$  (0.24 ml) was irradiated with UV light for 10 min. The volume of the solvent was removed under vacuum and the residue was loaded on a silica gel column. Elution with dichloromethane/hexane (20:80, v/v) gave the following in order of elution: trace amounts of

$\text{Fe}_3(\text{CO})_{12}$  and unreacted  $\text{Fe}_3(\text{CO})_9(\mu_3\text{-Se})_2$  followed by dark green  $\text{Fe}_4(\text{CO})_{11}(\mu_4\text{-Se})_2$ . Yield: 0.007 g (25%).

### Acknowledgement

The authors are grateful to Lovel Lewis for the use of the mass spectrometer facility at Cambridge.

### References

- 1 K. Whitmire, *J. Coord. Chem.*, 17 (1988) 95; N.A. Compton, R.J. Errington and N.C. Norman, *Adv. Organomet. Chem.*, 31 (1990) 91; R.D. Adams, *Polyhedron*, 4 (1985) 2003.
- 2 D.A. Lesch and T.B. Rauchfuss, *Organometallics*, 1 (1982) 499; L.E. Bogan, D.A. Lesch and T.B. Rauchfuss, *J. Organomet. Chem.*, 250 (1983) 429; D.A. Lesch and T.B. Rauchfuss, *Inorg. Chem.*, 22 (1983) 1854; V.W. Day, D.A. Lesch and T.B. Rauchfuss, *J. Am. Chem. Soc.*, 104 (1982) 1290; P. Mathur, I.J. Mavunkal and V. Rugmini, *J. Organomet. Chem.*, 367 (1989) 243.
- 3 T.M. Layer, J. Lewis, A. Martin, P.R. Raithby and W.-T. Wong, *J. Chem. Soc., Dalton Trans.*, (1992) 3411; B.F.G. Johnson, T.M. Layer, J. Lewis, A. Martin and P.R. Raithby, *J. Organomet. Chem.*, 429 (1992) C41; P. Mathur, Md. M. Hossain and R.S. Rashid, *J. Organomet. Chem.*, 448 (1993) 211.
- 4 P. Mathur, Md.M. Hossain, K. Das and U.C. Sinha, *J. Chem. Soc., Chem. Commun.*, (1993) 46.
- 5 P. Mathur, I.J. Mavunkal and A.L. Rheingold, *J. Chem. Soc., Chem. Commun.*, (1989) 382.
- 6 P. Mathur, I.J. Mavunkal and V. Rugmini, *Inorg. Chem.*, 28 (1989) 3616.
- 7 P. Mathur, I.J. Mavunkal, V. Rugmini and M.F. Mahon, *Inorg. Chem.*, 29 (1990) 4838.
- 8 P. Mathur, D. Chakrabarty, Md.M. Hossain and R.S. Rashid, *J. Organomet. Chem.*, 420 (1991) 79.
- 9 P. Mathur, B.H.S. Thimmappa and A.L. Rheingold, *Inorg. Chem.*, 29 (1990) 4658.
- 10 R.D. Adams, J.E. Babin, J. Estrada, J.-G. Wang, M.B. Hall and A.A. Low, *Polyhedron*, 8 (1989) 1885.
- 11 P. Mathur, D. Chakrabarty, Md.M. Hossain, R.S. Rashid, V. Rugmini and A.L. Rheingold, *Inorg. Chem.*, 31 (1992) 1106.