

Preparation and crystal structures of the mononuclear vanadium phenoxide complexes $[\text{VCl}(\text{OC}_6\text{H}_3\text{Pr}_2^{i-2,6})_2(\text{C}_4\text{H}_8\text{O})_2]$ and $[\text{VO}(\text{OC}_6\text{H}_3\text{Pr}_2^{i-2,6})_3]$: procatalysts for ethylene polymerisation

Richard A. Henderson^a, David L. Hughes^a, Zofia Janas^b, Raymond L. Richards^a,
Piotr Sobota^{b,*}, Stawomir Szafert^b

^a John Innes Centre, Nitrogen Fixation Laboratory, Norwich Research Park, Norwich NR4 7UH, UK

^b Faculty of Chemistry, University of Wrocław, 14 F. Joliot-Curie Street, Wrocław 50383, Poland

Received 13 October 1997

Abstract

The complexes $[\text{VCl}(\text{OC}_6\text{H}_3\text{Pr}_2^{i-2,6})_2(\text{thf})_2]$ **1** (thf, tetrahydrofuran) and $[\text{VO}(\text{OC}_6\text{H}_3\text{Pr}_2^{i-2,6})_3]$ **2** have been prepared and structurally characterised. Compound **1** has a distorted trigonal bipyramidal structure with apical thf ligands [$d(\text{V}-\text{O}_{\text{phenox}})$ 1.865(2), $d(\text{V}-\text{O}_{\text{thf}})$ 2.120(3) and $d(\text{V}-\text{Cl})$ 2.277(2) Å]. It reacts with $\text{Li}[\text{SC}_6\text{H}_2\text{Me}_3-2,4,6]$ to give $[\text{V}(\text{SC}_6\text{H}_2\text{Me}_3-2,4,6)(\text{OC}_6\text{H}_3\text{Pr}_2^{i-2,6})_2(\text{thf})_2]$. Compound **2**, which has trigonal pyramidal geometry, is disordered about a 2-fold crystallographic axis [$d(\text{V}=\text{O})$ 1.564(4), $d(\text{V}-\text{O}_{\text{av}})$ 1.761(1) Å]. Compounds **1** and **2** are pro-catalysts for the polymerisation of C_2H_4 . © 1998 Elsevier Science S.A. All rights reserved.

Keywords: Vanadium; Phenoxide; Crystal structure; Polymerisation

We are interested in the catalytic properties of vanadium centres, particularly relating to nitrogen fixation [1] and to polymerisation of alkenes [2]. As an aid to understanding the role of vanadium in vanadium nitrogenase, we are studying the binding of hydrazines and derived ligands at low-valent vanadium centres and have prepared complexes of the bulky phenoxide ligand $[\text{OC}_6\text{H}_3\text{Pr}_2^{i-2,6}]^-$, which was used to favour the formation of mononuclear vanadium centres, e.g. in such complexes as $[\text{V}(\text{OC}_6\text{H}_3\text{Pr}_2^{i-2,6})_3(\text{NH}_2\text{NMeR})_2]$ (R = Me or Ph) [1]. Whilst engaged in this work we discovered routes to two new monomeric phenoxide complexes and here we describe their structures and some of their reactions, principally in polymerisation studies.

1. Results and discussion

1.1. Preparation, structure and reactions of $[\text{VCl}(\text{OC}_6\text{H}_3\text{Pr}_2^{i-2,6})_2(\text{thf})_2]$ **1**

Compound **1** was obtained by the straightforward reaction of $[\text{VCl}_3(\text{thf})_3]$ with $\text{Li}[\text{OC}_6\text{H}_3\text{Pr}_2^{i-2,6}]$ in thf (Eq. (1)) as dark red, paramagnetic crystals with a magnetic moment ($\mu_{\text{eff}} = 2.6 \mu_{\text{B}}$) in the range expected for V^{III} complexes of this type with a d^2 high-spin configuration [1,3].

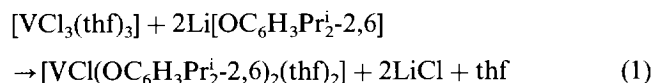

The crystal structure of compound **1** is shown in Fig. 1, with bond dimensions in Table 1. It has essentially trigonal bipyramidal geometry, with apical thf ligands

* Corresponding author. E-mail: PLAS@WCHUVE.CHEM.UNI.WROC.PL

and the two $\text{OC}_6\text{H}_3\text{Pr}_2\text{-2,6}$ groups and the chloride lying in the trigonal plane. The $\text{OC}_6\text{H}_3\text{Pr}_2\text{-2,6}$ ligands have their aromatic groups (related by a 2-fold symmetry axis) in the 'up-down' configuration relative to the trigonal plane. Compound **1** is an analogue of the complexes $[\text{V}(\text{OC}_6\text{H}_3\text{Me}_2\text{-2,6})_3(\text{C}_5\text{H}_5\text{N})_2]$ [3] and $[\text{V}(\text{OC}_6\text{H}_3\text{Pr}_2\text{-2,6})_3(\text{NH}_2\text{NMeR})_2]$ (R = Me or Ph) [1] which have trigonal bipyramidal geometry with the phenoxide ligands in the trigonal plane.

Compound **1** reacts with $\text{Li}[\text{SC}_6\text{H}_2\text{Me}_3\text{-2,4,6}]$ to give $[\text{V}(\text{SC}_6\text{H}_2\text{Me}_3\text{-2,4,6})(\text{OC}_6\text{H}_3\text{Pr}_2\text{-2,6})_2(\text{thf})_2]$ (Eq. (2))

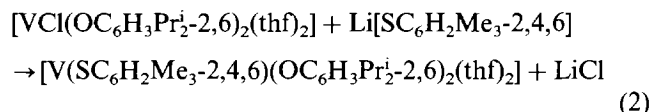

We attempted to prepare a dinitrogen-bridged complex by treatment of **1** with $\text{N}_2(\text{SiMe}_3)_4$ but dinitrogen was lost in the reaction, leading to the formation of $[\text{VO}(\text{OC}_6\text{H}_3\text{Pr}_2\text{-2,6})_3]$ **2**, as described below.

1.2. Preparation and structure of $[\text{VO}(\text{OC}_6\text{H}_3\text{Pr}_2\text{-2,6})_3]$ **2**

Compound **2** was obtained by three routes, the first being accidental, as mentioned above. Treatment of compound **1** with $\text{N}_2(\text{SiMe}_3)_4$ involved loss of dinitrogen from a transient intermediate which could not be isolated. Work up of the oily reaction product and standing of the resulting solution at low temperature for several days (Section 2) gave dark-red, diamagnetic crystals which have an IR band at 1000 cm^{-1} assignable to $(\text{V}=\text{O})$ and have been structurally characterised as $[\text{VO}(\text{OC}_6\text{H}_3\text{Pr}_2\text{-2,6})_3]$ **2** by X-ray crystallogra-

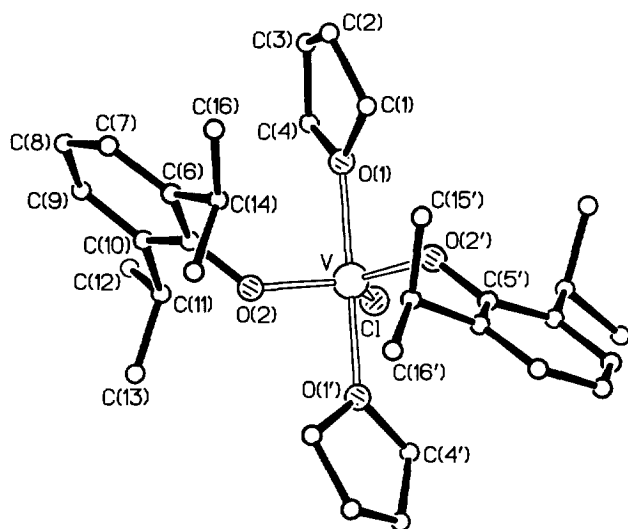

Fig. 1. The structure of a single molecule of $[\text{VCl}(\text{OC}_6\text{H}_3\text{Pr}_2\text{-2,6})_2(\text{thf})_2]$ **1**, the H atoms are omitted for clarity. A 2-fold symmetry axis passes through V and Cl and relates the two halves of the molecule.

Table 1

Selected molecular dimensions in $[\text{VCl}(\text{OC}_6\text{H}_3\text{Pr}_2\text{-2,6})_2(\text{thf})_2]$ **1**. Bond lengths are in Å and angles in degrees with estimated standard deviations in parentheses

(a) About the vanadium atom			
V–Cl	2.277(2)	V–O(2)	1.865(3)
V–O(1)	2.120(3)		
Cl–V–O(1)	92.2(1)	O(1)–V–O(2)	92.5(1)
Cl–V–O(2)	117.4(1)	O(1)–V–O(2')	85.5(1)
O(1)–V–O(1')	175.5	O(2)–V–O(2')	125.2(1)
(b) In the ligands			
O(1)–C(1)	1.447(6)	V–O(1)–C(1)	124.2(3)
O(1)–C(4)	1.451(7)	V–O(1)–C(4)	126.7(3)
		C(1)–O(1)–C(4)	109.2(4)
O(2)–C(5)	1.352(5)	V–O(2)–C(5)	133.2(3)

phy as described below. The origin of the $\text{V}=\text{O}$ group in **2** has not been established, but is very likely a result of hydrolysis by adventitious water of the presumably very reactive species formed after loss of N_2 from an intermediate produced during the early stages of the reaction. There also must be a step in the reaction sequence which generates the third $\text{OC}_6\text{H}_3\text{Pr}_2\text{-2,6}$ group found at vanadium in the product **2**. Having established the structure of compound **2**, we sought a rational synthesis of it and found that it can be obtained in high yield by treatment of $[\text{VO}(\text{OPr}')_3]$ with $\text{HOC}_6\text{H}_3\text{Pr}_2\text{-2,6}$ or treatment of $[\text{V}(\text{OC}_6\text{H}_3\text{Pr}_2\text{-2,6})_4\text{Li}(\text{thf})]$ with propylene oxide (Scheme 1 and Section 2).

The structure of compound **2** is shown in Fig. 2, with molecular dimensions in Table 2. It has trigonal pyramidal geometry about vanadium with the vanadium atom $0.633(1)$ Å out of the plane of the three phenoxide oxygen atoms. This is a rare geometry for V^{V} which has previously been described for the analogues $[\text{VO}(\text{OCH}_2\text{CH}_2\text{Cl})_3]$ [4] and $[\text{VO}(\text{OC}_5\text{H}_9)_3]$ [5], although in these cases each molecule interacts, via an alkoxide oxygen atom, with a second molecule in the solid state to give dimers with essentially trigonal bipyramidal environments for the vanadium atoms; in these complexes, the fifth V–O distance (opposite the vanadyl oxygen) is much longer, at $2.262(2)$ and $2.297(2)$ Å, respectively, and the V atoms are 0.32 and 0.35 Å out of the 'equatorial' planes of three alkoxide oxygen atoms. Evidently, the bulk of the $\text{OC}_6\text{H}_3\text{Pr}_2\text{-2,6}$ ligands in compound **2** prevents close intermolecular approach. A monomeric analogue, which also has bulky ligands, is $[\text{NbO}(\text{OC}_6\text{H}_3\text{Ph}_2\text{-2,6})_3]$ which shows no distant, fifth coordinating oxygen atom; here the Nb atom is displaced $0.70(2)$ Å from the plane of the O_3 trigonal base [6].

The molecule of **2** shows disorder about a crystallographic 2-fold symmetry axis which passes through the ligand binding through O(1) and relates the ligands binding through O(2) and O(2'); the vanadyl group is randomly disordered between sites related by this axis

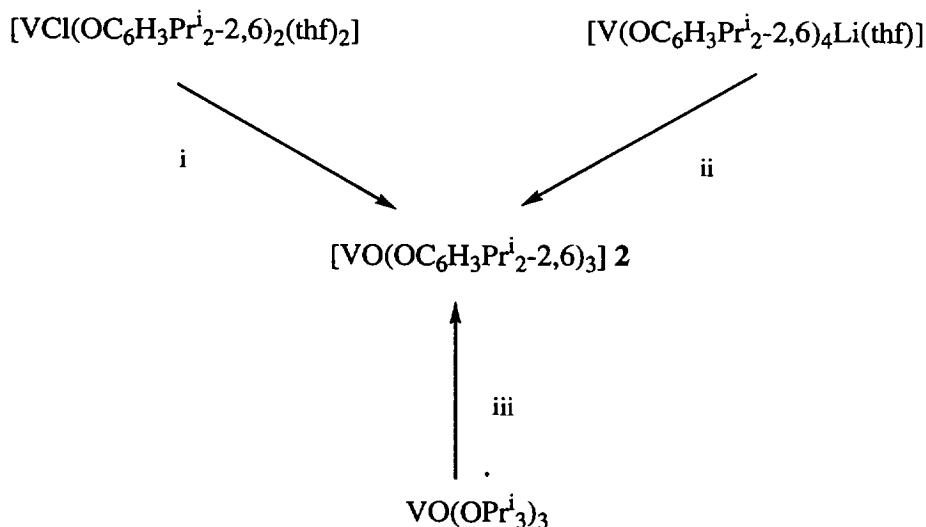
Scheme 1. (i) $\text{N}_2(\text{SiMe}_3)_4$, hexane; (ii) propylene oxide, hexane; (iii) $\text{HO}(\text{C}_6\text{H}_3\text{Pr}^i_{2-2,6})$, hexane.

(Fig. 3). There is no disorder in the phenyl rings on O(2) and O(2') but there is disorder in some of the isopropyl groups of those ligands (Fig. 2). These two phenoxide ligands are orientated almost perpendicularly to the O_3 base plane so that their isopropyl groups lie well above and below the base plane; the third phenoxide ligand, of O(1), lies with its phenyl ring plane much closer to the base plane and essentially normal to the other two phenyl rings. The $\text{V}-\text{O}_{\text{phenox}}$ distances, all 1.761(4) Å, and the $\text{V}=\text{O}$ distance, 1.564(4) Å, are close to those observed in the dimeric analogues, viz. in $[\{\text{VO}(\text{OCH}_2\text{CH}_2\text{Cl})_3\}_2]$ 1.80(3)_{av} and 1.584(2) Å [4] and in $[\{\text{VO}(\text{OC}_5\text{H}_9)_3\}_2]$ 1.79(2)_{av} and 1.595(2) Å [5]. In both dimers, there are two short $\text{V}-\text{O}_{\text{alkoxide}}$ distances, ca. 1.76 Å, and one longer one, ca. 1.85 Å (to

the bridging O atom).

In compound **2**, the $\text{V}-\text{O}(1)-\text{C}(11)$ angle, $136.3(4)^\circ$, is in the normal range for this type of bonding, but the other $\text{V}-\text{O}-\text{C}$ angles, both ca. 165° , are quite unexpectedly large and presumably result from the bulkiness of the ligands. In $[\{\text{VO}(\text{OC}_5\text{H}_9)_3\}_2]$, the $\text{V}-\text{O}-\text{C}$ angles are all ca. 131° and the $\text{O}-\text{C}$ bonds, viewed down the direction of the vanadyl bond, project straight out from the V atom and fold back from the base plane towards the side of the vanadyl group; in complex **2**, the three $\text{O}-\text{C}$ bonds project out similarly from the V atom and the tendency of these bonds to fold back towards the vanadyl side is again present but the large, 165° angles at O(2) and O(2') mean that these two bonds lie close to the O_3 base plane. The $\text{O}_{\text{vanadyl}}-\text{V}-\text{O}-\text{C}$ torsion angles in complex **2** are $0(1)$, $-15(1)$ and $+15(1)^\circ$, mean (of absolute values) 9.9° ; in $[\{\text{VO}(\text{OCH}_2\text{CH}_2\text{Cl})_3\}_2]$, the corresponding mean (absolute) torsion angle is 8.2° and in $[\{\text{VO}(\text{OC}_5\text{H}_9)_3\}_2]$ 3.5° , showing that the orientations about the oxygen atoms of the alkoxide and phenoxide

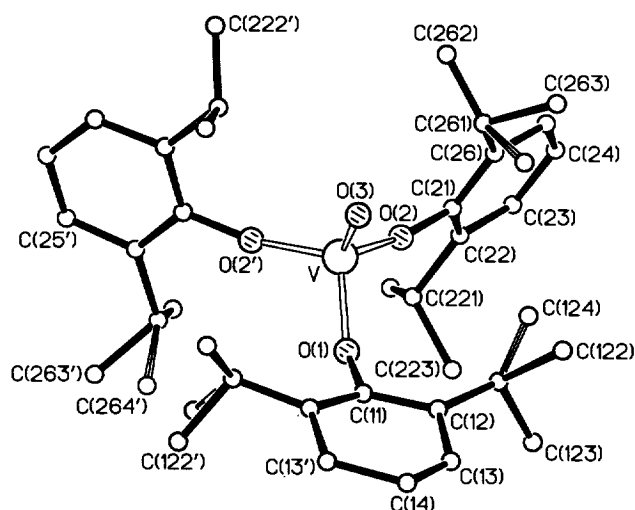

Fig. 2. View of a single molecule of $[\text{VO}(\text{OC}_6\text{H}_3\text{Pr}^i_{2-2,6})_3] \mathbf{2}$ showing the disorder in the isopropyl ligands and the atom numbering scheme; a 2-fold symmetry axis relates the ligand of O(2) with that of O(2'), and passes through the ligand of O(1).

Table 2

Selected molecular dimensions in $[\text{VO}(\text{OC}_6\text{H}_3\text{Pr}^i_{2-2,6})_3] \mathbf{2}$. Bond lengths are in Å and angles in degrees with estimated standard deviations in parentheses

(a) About the vanadium atom			
$\text{V}-\text{O}(1)$	1.761(4)	$\text{V}-\text{O}(2)^\text{a}$	1.761(2)
$\text{V}-\text{O}(2)$	1.761(2)	$\text{V}-\text{O}(3)$	1.564(4)
$\text{O}(1)-\text{V}-\text{O}(2)$	108.1(2)	$\text{O}(2)-\text{V}-\text{O}(2')$	108.1(1)
$\text{O}(1)-\text{V}-\text{O}(2')$	107.2(2)	$\text{O}(2)-\text{V}-\text{O}(3)$	112.8(2)
$\text{O}(1)-\text{V}-\text{O}(3)$	107.3(2)	$\text{O}(2')-\text{V}-\text{O}(3)$	113.0(2)
(b) In the ligands			
$\text{O}(1)-\text{C}(11)$	1.383(6)	$\text{V}-\text{O}(1)-\text{C}(11)$	136.3(4)
$\text{O}(2)-\text{C}(21)$	1.360(3)	$\text{V}-\text{O}(2)-\text{C}(21)$	165.9(2)
		$\text{V}(2)-\text{C}(21')$	164.3(2)

^a The primed atoms are those in the other half of the molecule at $0.25-x, y, 0.25-z$.

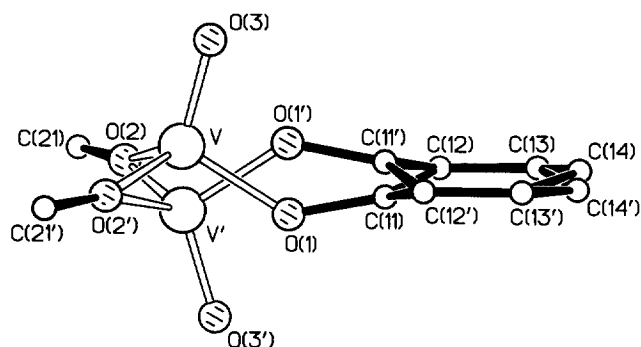

Fig. 3. Showing the principal disorder of the molecules of complex **2** about a crystallographic 2-fold symmetry axis. There is no disorder in the phenyl groups of O(2) {and O(2')}. Resolution of C(12) and C(13), from C(16') and C(15'), respectively, was not possible.

ligands are similar in the three complexes. In the niobium monomer with the bulky phenoxide ligands [6], the Nb–O–C angles are also large, in the range 146.1–155.0°, and the orientations about the O_{phenox} atoms are again similar to those above with a mean (absolute) torsion angle of 16.2°. However, in this complex, the phenoxide ligands are tilted, propellor-wise, about a pseudo 3-fold axis, quite differently from the arrangement in complex **2**.

In its NMR spectra (Section 2) compound **2** shows the expected 1:2 relative intensity ¹H patterns for the methyne protons (overlapping sextets) and the methyl protons (overlapping doublets) and a ⁵¹V shift, (–531.6 ppm rel. VOCl₃), in the region expected for VO(OR)₃ compounds [4].

1.3. Polymerisation studies

The ethylene polymerisation catalysts were prepared in n-hexane by milling a slurry of [MgCl₂(thf)₂] with the vanadium compound and diethylaluminium chloride as the cocatalysts. The results of ethylene polymerisation are shown in Table 3. The catalytic activity of both systems increases with temperature and is highest at 343 K to yield 243 and 160 kg polyethylene g^{–1} h^{–1} for **1** and **2**, respectively. Addition of [MgCl₂(thf)₂] to the vanadium catalyst precursors did not significantly raise the activity and therefore it was a non-essential component. However, when the vanadium catalysts were used without [MgCl₂(thf)₂], polyethylene usually fouled the reactor so badly that the results were difficult to reproduce. The activity of **1** is comparable to vanadium(III) chloride-based catalysts [VCl₃(thf)₃] and [V₂(μ-Cl)₂Cl₄(thf)₄] which produced > 200 kg polyethylene g^{–1} h^{–1} at 323 K [7] and is significantly lower than that for [V₂Mg₂(μ₃,η²-thffo)₂(μ,η²-thffo)₄Cl₄]·2CH₂Cl₂ (thffo, 2-tetrahydrofurfuroxide) (410 kg polyethylene g^{–1} h^{–1}) [2]. Vanadium alkoxide systems have the advantage of producing polymer with narrow molecu-

lar weight distribution and excellent morphology [8]. Although the **2**–AlEt₂Cl catalyst system polymerised ethylene with lower activity than **1**–AlEt₂Cl, preliminary experiments show that compound **2** in presence of methylaluminoxane (MAO) exhibits significantly higher activity (45 kg polyethylene g^{–1} h^{–1}) than vanadium(V) imido-ligand stabilised procatalysts (< 1 kg polyethylene g^{–1} h^{–1}), for which V^V is suggested to be the oxidation state of the catalyst [9]. We suppose that in the **2**–AlEt₂Cl and **2**–MAO catalysts the active vanadium species has a lower oxidation state than V^V and we plan further studies to clarify this point. Generally, vanadium-based catalysts show configurations d² and d³; d⁰ vanadium complexes have frequently been used as catalysts but are readily reduced to lower oxidation states on addition of cocatalysts [10]. It has not been excluded, however, that vanadium(V) complexes would also be effective catalysts if they could be stabilised in their high oxidation states [11].

It is worthy of note that the catalysts of this study show also high activity in ethylene copolymerisation with hex-1-ene to produce, under the same conditions, 170 and 102 kg polymer g^{–1} h^{–1} for **1** and **2**, respectively.

2. Experimental

All operations were carried out under a dry dinitrogen or argon atmosphere using standard Schlenk and glove box techniques. All solvents were distilled under dinitrogen from the appropriate drying agents prior to use. IR spectra were recorded on a Perkin-Elmer 882 instrument in Nujol mulls and NMR spectra on a JEOL GSX-270 instrument. Analyses were performed at the University of Wrocław. Magnetic moments were determined in solution using the NMR method of Evans and James [12].

Table 3
Polymerisation^a of ethylene with V–MgCl₂–AlEt₂Cl catalyst

T (K)	Productivity ^b /kg PE g ^{–1} V h ^{–1}
[VCl(OC ₆ H ₃ Pr ₂ -2,6) ₂ (thf) ₂] 1	
303	71
323	185 (33) ^c
343	243 (98) ^c
[VO(OC ₆ H ₃ Pr ₂ -2,6) ₃] 2	
303	87
323	123 (65) ^c
343	160 (55) ^c

^a Polymerisation conditions: [V]₀ = 0.01 mmol dm^{–3}, [Al] = 5 mmol dm^{–3}, Mg: V = 10, P_{ethylene} = 0.6 MPa, in hexene.

^b Productivity is the mass in kg of polymer formed per g of vanadium atom in 1 h.

^c Precatalyst activated MAO (10% solution in toluene), [Al] = 10 mmol dm^{–3}, [V] = 0.01 mmol dm^{–3}.

The compounds $\text{HOC}_6\text{H}_3\text{Pr}_2^i\text{-2,6}$, trimethylsilyl chloride, hydrazine and vanadium trichloride were obtained from Aldrich. The compounds $[\text{V}(\text{OC}_6\text{H}_3\text{Pr}_2^i\text{-2,6})_4\text{Li}(\text{thf})]$ [13], $[\text{VCl}_3(\text{thf})_3]$ [14], $\text{N}_2(\text{SiMe}_3)_4$ [15] and $\text{HSC}_6\text{H}_2\text{Me}_3\text{-2,4,6}$ [16] were prepared by literature methods.

2.1. Preparation of $[\text{VCl}(\text{OC}_6\text{H}_3\text{Pr}_2^i\text{-2,6})_2(\text{thf})_2]$ **1**

A solution of $[\text{VCl}_3(\text{thf})_3]$ (0.7 g, 1.87 mmol) and $\text{Li}(\text{OC}_6\text{H}_3\text{Pr}_2^i\text{-2,6})$ (0.69 g, 3.75 mmol) in thf (50 cm³) was stirred for 12 h to give a dark red solution which was taken to dryness in a vacuum and the residue extracted with hexane (3 × 30 cm³). The resulting solution was concentrated in a vacuum to 15 cm³ and kept at low temperature (ca. -4°C) when dark red crystals deposited. These were filtered off, washed with hexane, dried in a vacuum and used for X-ray studies. Yield 0.77 g (70%). $\mu_{\text{eff}} = 2.6 \mu_{\text{B}}$. (Found: C, 65.7; H, 8.7; Cl, 5.9. $\text{C}_{32}\text{H}_{50}\text{O}_4\text{ClV}$ requires: C, 65.7; H, 8.6; Cl, 6.0%)

2.2. Preparation of $[\text{V}(\text{SC}_6\text{H}_2\text{Me}_3\text{-2,4,6})(\text{OC}_6\text{H}_3\text{Pr}_2^i\text{-2,6})_2(\text{thf})_2]$

To a solution of **1** (1.2 g, 2.05 mmol) in thf (50 cm³) was added $\text{Li}[\text{SC}_6\text{H}_2\text{Me}_3\text{-2,4,6}]$ (0.5 g, 2.05 mmol) and the mixture stirred for 5 h. The reaction mixture turned from brown/red to olive. The solvent was evaporated to dryness, the residue extracted with hexane (3 × 30 cm³) and the resulting solution concentrated to 10 cm³ and left at low temperature (ca. -4°C) when an olive-brown solid deposited which was filtered off, washed with hexane and dried in a vacuum. Yield 50%. Although the compound is too thermally unstable (changing to a red oil) to permit crystallisation, it was sufficiently stable for characterisation by microanalysis. $\mu_{\text{eff}} = 2.6 \mu_{\text{B}}$. (Found: C, 69.7; H, 8.3; S, 4.9. $\text{C}_{41}\text{H}_{61}\text{O}_4\text{SV}$ requires: C, 70.3; H, 8.7; S, 4.6%).

2.3. Preparation of $[\text{VO}(\text{OC}_6\text{H}_3\text{Pr}_2^i\text{-2,6})_3]$ **2**

2.3.1. Method 1

Compound **1** (0.5 g, 0.85 mmol) was dissolved in hexane and $\text{N}_2(\text{SiMe}_3)_4$ (0.27 g, 0.85 mmol) was added. The reaction mixture was stirred for 24 h then the solvent was removed in a vacuum, to leave an oily residue which was heated at 60°C in a vacuum to remove volatile silylated byproducts. The cooled residue was then extracted with hexane and allowed to stand at ca. -4°C for several days during which time dark red crystals deposited which were filtered off and used for X-ray structure determination. In a separate experiment, $[\text{VCl}(\text{OC}_6\text{H}_3\text{Pr}_2^i\text{-2,6})_2(\text{thf})_2]$ **1** (1.06 g, 1.8 mmol) in hexane (60 cm³) was treated with $\text{N}_2(\text{SiMe}_3)_4$ (0.58 g, 1.8 mmol) and N_2 (22 cm³, 0.98 mmol, gas chromatography) was evolved.

2.3.2. Method 2

To a green solution of $[\text{V}(\text{OC}_6\text{H}_3\text{Pr}_2^i\text{-2,6})_4\text{Li}(\text{thf})]$ in hexane (30 cm³) [generated from $[\text{VCl}_3(\text{thf})_3]$ (0.5 g, 1.34 mmol) and $\text{Li}[\text{OC}_6\text{H}_3\text{Pr}_2^i\text{-2,6}]$ (0.99 g, 5.36 mmol)] was added propylene oxide (0.1 cm³, 1.43 mmol). After the solution was stirred for 2 days, it had become dark red and was filtered, concentrated in a vacuum to 10 cm³ and left at ca. -4°C to form red crystals which were filtered off, washed with hexane and dried in a vacuum (80%). (Found: C, 71.9; H, 8.6. $\text{C}_{36}\text{H}_{51}\text{O}_4\text{V}$ requires: C, 72.2; H, 8.6%). IR: $\nu(\text{VO})$ 1000 cm⁻¹. NMR (C_6H_6): ^1H δ 7.16–6.94 (Ph multiplet), 3.96–3.78 [$\text{CH}(\text{CH}_3)_2$, two overlapping sextets, 1:2 ratio], 1.29–1.24 [$\text{CH}(\text{CH}_3)_2$, two overlapping doublets, 1:2 ratio]; ^{51}V δ -531.6 (s).

2.3.3. Method 3

To a solution of $[\text{VO}(\text{OPr}^i)_3]$ (0.51 g, 2.1 mmol) in n-hexane (30 cm³) was added $\text{HOC}_6\text{H}_3\text{Pr}_2^i\text{-2,6}$ (1.12 g, 6.3 mmol). The mixture turned immediately red/brown and after stirring for 3 h and evaporation of solvent to half volume, reddish, crystalline compound **2** precipitated. Yield 1.06 g (85%).

2.4. Polymerisation tests

A slurry of $[\text{MgCl}_2(\text{thf})_2]$ (30 mmol) in n-hexane was milled under argon in a glass mill (capacity 250 cm³, with 20 balls of diameter 5–15 mm) at room temperature for 6 h. Then the vanadium compound (3 mmol) and n-hexane (50 cm³) were added and the mixture was milled for 24 h. The sample of precatalyst suspension (containing 0.01% vanadium) was activated with AlEt_2Cl (20 mmol) or MAO (10% solution in toluene) for 15 min at 323 K under argon to form the highly active catalyst. The polymerisation of ethylene was carried out at 303–343 K in a stainless-steel reactor (1 dm³) equipped with a stirrer, in n-hexane at an ethylene pressure of 0.6 MPa. The polymerisation was quenched with a 5% solution of HCl in methanol (150 cm³) and the polymer was filtered off, washed with methanol and dried under vacuum. Further details of polymerisation conditions, yields, etc. are shown in Table 3.

3. Crystallography

3.1. $[\text{VCl}(\text{OC}_6\text{H}_3\text{Pr}_2^i\text{-2,6})_2(\text{thf})_2]$ **1**

Crystal data: $\text{C}_{32}\text{H}_{50}\text{ClO}_4\text{V}$, $M = 585.11$, monoclinic, space group $C2/c$, $a = 21.187(4)$, $b = 9.853(2)$, $c = 15.965(3)$ Å, $\beta = 93.90(2)^\circ$, $U = 3325(2)$ Å³, $Z = 4$, $D_c = 1.169(1)$ g cm⁻³, $D_m = 1.179$ g cm⁻³, $F(000) = 1256$, $T = 180.0(2)$ K, $\mu(\text{Mo-K}\alpha) = 0.41$ mm⁻¹, $\lambda(\text{Mo-K}\alpha) = 0.71069$ Å.

Crystals are red/brown needles and were cut down for use. One, ca. $0.5 \times 0.4 \times 0.3$ mm was sealed in a glass capillary. On a Kuma KM4 four-circle diffractometer, cell parameters were calculated from the settings of 25 reflections having $\theta = 7\text{--}12.5^\circ$, and diffraction intensities were measured to $\theta_{\max} = 23^\circ$. There was no crystal decay and 3294 reflections were measured of which 1510 were unique.

The structure was solved by the Patterson method and refined by full-matrix least-squares calculations using SHELXL-93 [17]. Neutral atom scattering factors were from ref. [18] and real and imaginary components of anomalous dispersion were included for all non-H atoms. Absorption corrections following the DIFABS [19] procedure were applied: minimum and maximum absorption corrections were 0.861 and 1.129, respectively. The hydrogen atoms of CH_2 and CH_3 groups were put in calculated positions with $d(\text{C-H}) = 1.08 \text{ \AA}$ and introduced as fixed contributors in the final stage of refinement. At the conclusion of refinement, the R_1 and wR_2 [17] values were 0.051 and 0.128, respectively for the 1394 reflections with $I > 3\sigma(I)$ using a weighting scheme of the form $w = 1/\{\sigma^2(F_o^2) + (0.0826P)^2 + 2.79P\}$ with $P = (F_o^2 + 2F_c^2)/3$. For the last cycle of refinement the maximum value of the ratio Δ/σ was below 0.014 and the final difference map showed a general background within -0.19 and 0.43 e \AA^{-3} .

3.2. $[\text{VO}(\text{OC}_6\text{H}_3\text{Pr}^i_2-2,6)_3]_2$

Crystal data: $\text{C}_{36}\text{H}_{51}\text{O}_4\text{V}$, $M = 598.7$. Monoclinic, space group $F2/d$ (equivalent to no. 15), $a = 31.787(5)$, $b = 10.092(2)$, $c = 22.599(5) \text{ \AA}$, $\beta = 107.83(3)^\circ$, $U = 6901(2) \text{ \AA}^3$, $Z = 8$, $D_c = 1.152 \text{ g cm}^{-3}$, $F(000) = 2576$, $T = 180(2) \text{ K}$, $\mu(\text{Mo-K}\alpha) = 3.1 \text{ cm}^{-1}$, $\lambda(\text{Mo-K}\alpha) = 0.71069 \text{ \AA}$.

Crystals are dark red and one, ca. $0.5 \times 0.4 \times 0.4$ mm, was mounted in a glass capillary on the Kuma diffractometer as above. A total of 3984 unique reflections to $\theta_{\max} = 27.5^\circ$, 2106 of which were 'observed' with $I > 2\sigma(I)$, were entered into the SHELX program system [20].

During processing, corrections were applied for Lorentz-polarisation effects; there was no crystal deterioration. The structure was determined by direct methods in the SHELXS program [21] and refined by full-matrix least-squares methods [20]. There is disorder in the molecule: a 2-fold symmetry axis passes through the molecule—it passes roughly through one phenoxide ligand, the second and third phenoxide ligands are related by the symmetry, and the vanadyl group is randomly disordered in sites related by the axis. Some of the isopropyl groups are also disordered, with the methyl groups in the principal orientation in 70–80% of the sites. Hydrogen atoms were included in idealised positions; those on phenyl rings and in ordered CH

groups were set to ride on the parent C atoms, while the methyl hydrogen atoms and the major-occupancy disordered CH atoms were refined with geometrical constraints. Hydrogen atoms of the minor-occupancy CH and methyl groups were not included, and further resolution of the disordered groups was not possible. The non-H atoms (except the disordered methyl C atoms in the minor orientations) were refined with anisotropic thermal parameters. The isotropic temperature factors of the minor occupation C atoms and the hydrogen atoms were allowed to refine freely. At the conclusion of the refinement, $R = 0.078$ and $R_g = 0.075$ for 2444 reflections with $I > \sigma(I)$ and weighted $w = (\sigma_F^2 + 0.00045F^2)^{-1}$. In the final difference map, the highest peak (at ca. 0.3 e \AA^{-3}) was in one of the disordered isopropyl groups. Refinement in the corresponding non-centrosymmetric space group, Fd (equivalent to Cc, no. 9) did not improve the model nor the results.

Scattering factors for neutral atoms were taken from ref. [18]. Computer programs used in this analysis have been noted above or in Table 4 of ref. [22], and were run on a DEC-AlphaStation 200 4/100 in the Nitrogen Fixation Laboratory, John Innes Centre.

Acknowledgements

We thank the Polish State Committee for Scientific Research, the BBSRC, the British Council and the EC for support, and Dr Krzysztof Szczegot of the University of Opole for preliminary polymerisation tests.

References

- [1] C. Le Floc'h, R.A. Henderson, P.B. Hitchcock, et al., *J. Chem. Soc. Dalton Trans.* (1996) 2755 and references therein.
- [2] Z. Janas, P. Sobota, M. Kasprzak, T. Gtowiak, *J. Chem. Soc. Chem. Commun.* (1996) 2727 and references therein.
- [3] S. Gambarotta, F. van Bolus, M.Y. Chang, *Inorg. Chem.* 26 (1987) 4303.
- [4] W. Priebsch, D. Rehder, *Inorg. Chem.* 29 (1990) 3013.
- [5] F. Hillerns, F. Olbrich, U. Behrens, D. Rehder, *Angew. Chem. Int. Ed. Engl.* 31 (1992) 447.
- [6] J.S. Yu, P.E. Fanwick, I.P. Rothwell, *Acta Crystallogr.* C48 (1992) 1759.
- [7] P. Sobota, J. Ejfler, S. Szafert, T. Gtowiak, I.O. Fritzky, K. Szczegot, *J. Chem. Soc. Dalton Trans.* (1995) 1727.
- [8] F.J. Karol, S.C. Kao, *New J. Chem.* 18 (1994) 97.
- [9] S. Scheuer, J. Fischer, J. Kress, *Organometallics* 14 (1995) 2627.
- [10] S. Jiao, D. Yu, *Polym. J.* 17 (1985) 899 and references therein.
- [11] F.J. Feher, R.L. Blanski, *Organometallics* 12 (1993) 958.
- [12] D.F. Evans, T.A. James, *J. Chem. Soc. Dalton Trans.* (1979) 723.
- [13] W.C.A. Wilisch, M.J. Scott, W.H. Armstrong, *Inorg. Chem.* 27 (1988) 4333.
- [14] L.E. Manzer, *Inorg. Synth.* 21 (1982) 138.
- [15] K. Seppelt, W. Sundermeyer, *Chem. Ber.* 102 (1969) 1247.

- [16] P.J. Blower, J.R. Dilworth, J.P. Hutchinson, J.A. Zubieta, *J. Chem. Soc. Dalton Trans.* (1985) 1533.
- [17] G.M. Sheldrick, SHELXL-93, Program for crystal structure refinement, University of Göttingen, Germany, 1993.
- [18] (a) *International Tables for X-ray Crystallography*, vol. 4, Kynoch Press, Birmingham, 1974, pp. 99 and 149. (b) *International Tables for X-ray Crystallography*, vol. C, Kynoch Press, Birmingham, 1992, Tables 4.2.6.8 and 6.1.1.4.
- [19] N. Walker, D. Stuart, *Acta Crystallogr. Sect. A* 39 (1983) 158.
- [20] G.M. Sheldrick, SHELX, Program for crystal structure determination, University of Cambridge, 1976.
- [21] G.M. Sheldrick, *Acta Crystallogr. Sect. A* A46 (1990) 467.
- [22] S.N. Anderson, R.L. Richards, D.L. Hughes, *J. Chem. Soc. Dalton Trans.* (1986) 245.