

Synthesis of doubly-bridged Fe/Se and Fe/Te complexes via reactions of the $[\text{MgX}]^+$ salts of anions $[(\mu\text{-RE})(\mu\text{-CO})\text{Fe}_2(\text{CO})_6]^-$ (E = Se, Te). Crystal structure of $(\mu\text{-}p\text{-MeC}_6\text{H}_4\text{Te})(\mu\text{-PhC=NPh})\text{Fe}_2(\text{CO})_6$

Li-Cheng Song ^{a,*}, Guo-Liang Lu ^a, Qing-Mei Hu ^a, Xiang-Dong Qin ^a, Cui-Xiang Sun ^a,
Jing Yang ^a, Jie Sun ^b

^a Department of Chemistry, Nankai University, Tianjin 300071, People's Republic of China

^b Laboratory of Organometallic Chemistry at Shanghai Institute of Organic Chemistry, Shanghai 200032, People's Republic of China

Received 28 April 1998; received in revised form 27 July 1998

Abstract

The reactions of Grignard reagents RMgX with elemental Se or Te in THF, followed by treatment of the intermediates RSeMgX or RTeMgX with $\text{Fe}_3(\text{CO})_{12}$ at room temperature (r.t.), were found to give $[\text{MgX}]^+$ salts of anions $[(\mu\text{-RSe})(\mu\text{-CO})\text{Fe}_2(\text{CO})_6]^-$ (**2**) and $[(\mu\text{-RTe})(\mu\text{-CO})\text{Fe}_2(\text{CO})_6]^-$ (**3**), respectively. Furthermore, the $[\text{MgX}]^+$ salts of anions **2** (R = Et) reacted in situ with the electrophile Ph_2AsCl to afford $(\mu\text{-EtSe})(\mu\text{-Ph}_2\text{As})\text{Fe}_2(\text{CO})_6$ (**4**), whereas the $[\text{MgX}]^+$ salts (R = *p*- MeC_6H_4) reacted with the electrophile PhNCS , followed by treatment with another electrophile MeI to give $(\mu\text{-}p\text{-MeC}_6\text{H}_4\text{Se})(\mu\text{-PhN(Me)C=S})\text{Fe}_2(\text{CO})_6$ (**5**). Similarly, the $[\text{MgX}]^+$ salts of anions **3** (R = Et, *t*-Bu, *i*-Bu) were found to react sequentially with the electrophiles $\text{PhC}\equiv\text{CPh}$ and CF_3COOH to yield $(\mu\text{-RTe})(\mu\text{-}\sigma,\pi\text{-PhC=CHPh})\text{Fe}_2(\text{CO})_6$ (**6a**, R = Et; **6b**, R = *t*-Bu; **6c**, R = *i*-Bu), whereas reactions of the $[\text{MgX}]^+$ salts of anions **3** (R = Et, Ph, *p*- MeC_6H_4) with the electrophiles Ph_2AsCl or PhC(Cl)NPh produced $(\mu\text{-RTe})(\mu\text{-Ph}_2\text{As})\text{Fe}_2(\text{CO})_6$ (**7a**, R = Et; **7b**, R = *p*- MeC_6H_4) and $(\mu\text{-RTe})(\mu\text{-PhC=NPh})\text{Fe}_2(\text{CO})_6$ (**8a**, R = *a*(axial)-Ph; **8b**, R = *e*(equatorial)-Ph; **9a**, R = *a*-*p*- MeC_6H_4 ; **9b**, R = *e*-*p*- MeC_6H_4), respectively. The reaction courses for the formation of Fe/Se and Fe/Te complexes **4–9** were discussed briefly and the structures of these new complexes, along with two other new Fe/Te complexes $(\mu\text{-RTe})_2\text{Fe}_2(\text{CO})_6$ (R = Et, *i*-Bu), were characterized by elemental analysis and spectroscopy, as well as for complex **9b**, whose structure was confirmed further by X-ray diffraction analysis. © 1998 Elsevier Science S.A. All rights reserved.

Keywords: Selenium; Tellurium; Iron; CO-bridged anions; Electrophiles; X-ray structure

1. Introduction

As is well-known, the reactions of anions $[(\mu\text{-RE})(\mu\text{-CO})\text{Fe}_2(\text{CO})_6]^-$ (**1**, E = S [1,2]; **2**, E = Se [2]; **3**, E = Te [3]) are of considerable interest and have been utilized extensively in the synthesis of a variety of organometallic complexes containing one or more $(\mu\text{-RE})\text{Fe}_2(\text{CO})_6$ structural units. For anions **1–3** most of the reactions so far studied, according to the electrophiles employed, might be divided into two types. In one type, reactions with the electrophiles having a leaving group afforded

neutral products in which the organic or inorganic group replaced the $\mu\text{-CO}$ ligand, such as in Refs. ([1]a) and ([2]a). In the other type, reactions with the electrophiles without a leaving group, initially gave another anions and finally produced the neutral products through further reaction of the anions with additional electrophiles, such as in Refs. ([1]b) and ([2]b). In order to further develop the chemistry of anion **2** and, particularly, anion **3**, we recently prepared some of the new $[\text{MgX}]^+$ salts of **2** and **3**, and explored their reactions with various electrophiles. Interestingly, these reactions yielded a series of new doubly-bridged Fe/Se and Fe/Te complexes. In this report, we describe the synthesis and

* Corresponding author. Fax: +86 22 23504853.

characterization of such Fe/Se and Fe/Te complexes, as well as the single-crystal molecular structure of a doubly-bridged Fe/Te complex $(\mu\text{-}p\text{-MeC}_6\text{H}_4\text{Te})(\mu\text{-PhC=NPh})\text{Fe}_2(\text{CO})_6$.

2. Results and discussion

2.1. Synthesis and characterization of $(\mu\text{-EtSe})(\mu\text{-Ph}_2\text{As})\text{Fe}_2(\text{CO})_6$ (**4**) and $(\mu\text{-}p\text{-MeC}_6\text{H}_4\text{Se})(\mu\text{-PhN(Me)CS})\text{Fe}_2(\text{CO})_6$ (**5**)

We found that the RSeMgX ($\text{R} = \text{Et}, p\text{-MeC}_6\text{H}_4, \text{X} = \text{Br}$) prepared from an insertion reaction of Grignard reagents RMgX with elemental selenium reacted with $\text{Fe}_3(\text{CO})_{12}$ in THF at r.t. to give a THF solution of the salts $[(\mu\text{-RSe})(\mu\text{-CO})\text{Fe}_2(\text{CO})_6][\text{MgX}]$ (denoted as $2 \cdot [\text{MgX}]$; $\text{R} = \text{Et}, p\text{-MeC}_6\text{H}_4, \text{X} = \text{Br}$) (Eq. 1). It was believed that such salts had been formed since the IR spectrum of the THF solution of $2 \cdot [\text{MgX}]$ ($\text{R} = \text{Et}$) showed a medium absorption band at 1735 cm^{-1} for its $\mu\text{-CO}$ ligand, which was similar to that of the $[\text{Et}_3\text{NH}]^+$ salt of anion **2** ($\text{R} = \text{Ph}$) showing a corresponding absorption band at 1740 cm^{-1} [4].

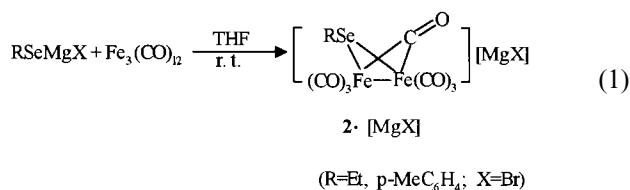

Interestingly, we further found that the intermediate salt of anion **2** ($\text{R} = \text{Et}$) reacted in situ with electrophilic Ph_2AsCl to give a doubly-bridged Fe/Se complex **4** in a 22% yield, whereas the intermediate salt of

anion **2** ($\text{R} = p\text{-MeC}_6\text{H}_4$) reacted in situ with electrophilic PhNCS , followed by further treatment with another electrophile MeI to afford a doubly-bridged Fe/Se complex **5** in a 35% yield (Scheme 1).

Mechanistically, product **4** could be viewed as formed via a simple $\text{S}_{\text{N}}2$ process with attack of the negatively-charged Fe of anion **2** at the As atom of Ph_2AsCl to eliminate chloride ion and subsequent coordination of the lone electron pair of As and concurrent loss of the $\mu\text{-CO}$ ligand; product **5** might be similarly envisioned as produced through the nucleophilic Fe attack at the carbon of PhNCS , followed by coordination of the lone electron pair of S and the concomitant loss of the $\mu\text{-CO}$ ligand to generate a nitrogen-centered anion. Subsequent electrophilic reaction of this nitrogen anion with MeI gave the final *N*-methylation product **5** (Scheme 1).

It is worth pointing out that the above synthetic method for doubly-bridged Fe/Se complexes based on $2 \cdot [\text{MgX}]$ salts is more convenient and more feasible than that based on $2 \cdot [\text{Et}_3\text{NH}]$ salts. This is because the alkylselenols RSeH , particularly their lower homologues, such as EtSeH , used for making $2 \cdot [\text{Et}_3\text{NH}]$ salts, are highly toxic and are much more difficult to prepare than the alkylselenate RSeMgX utilized for the preparation of $2 \cdot [\text{MgX}]$ salts. In addition, it is impossible to prepare product **5** from $2 \cdot [\text{Et}_3\text{NH}]$ ($\text{R} = p\text{-MeC}_6\text{H}_4$) since the intermediate nitrogen anion will be protonated preferentially by the proton of the counterion $[\text{Et}_3\text{NH}]$ to give another product $(\mu\text{-}p\text{-MeC}_6\text{H}_4\text{Se})(\mu\text{-PhN(H)C=S})\text{Fe}_2(\text{CO})_6$ [5].

Products **4** and **5** are air-stable red solids, which have been characterized by elemental analysis and spectroscopy. In principle, **4** would exist, similar to its sulfur analogs [6], as only one isomer, in which the R

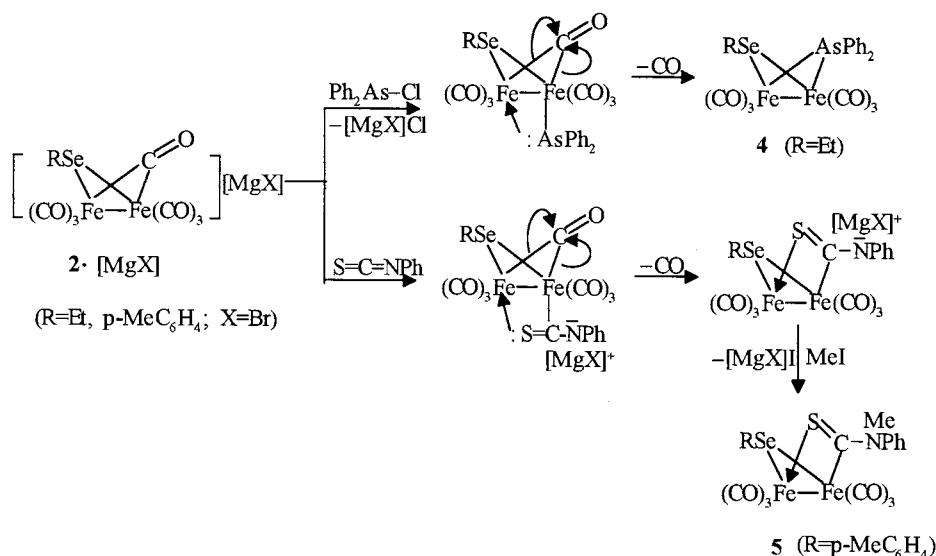

Scheme 1.

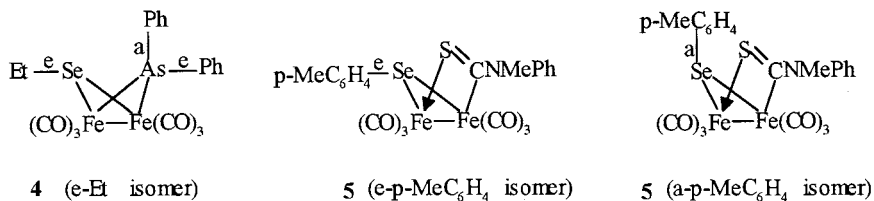

Scheme 2.

group is attached to Se atom by an *equatorial* bond to minimize its steric repulsion with an *axial* Ph group located on the As atom. In fact, the ¹H-NMR spectrum of **4** did show that the ethyl group is oriented *equatorially*, since its SeCH₂ proton NMR consists of only one set of quartets at 2.48 ppm [6] (Scheme 2).

Although **5** might exist theoretically as two isomers (Scheme 2) (one with an *equatorial* R and the other with an *axial* R since no *axial* substituent in bridged Ph(Me)NCS ligand), they would probably exist also as one isomer either the *e*(*p*-MeC₆H₄) or the *a*(*p*-MeC₆H₄) isomer (Scheme 2), since the *p*-Me ¹H-NMR signal in *p*-MeC₆H₄ group attached to Se in **5** showed only one singlet at 2.25 ppm. However, we could not establish it as the *e*(*p*-MeC₆H₄) or the *a*(*p*-MeC₆H₄) isomer due to lack of comparable ¹H-NMR data associated with this assignment.

2.2. Synthesis and characterization of (μ -RTe)(μ - σ , π -PhC=CHPh)Fe₂(CO)₆ (**6a–c**), (μ -RTe)(μ -Ph₂As)Fe₂(CO)₆ (**7a,b**) and (μ -RTe)(μ -PhC=NPh)Fe₂(CO)₆ (**8a,b**, **9a,b**)

Since we reported the first preparation of Te-containing anions [(μ -RTe)(μ -CO)Fe₂(CO)₆][−] (**3**) [3], it is possible to make comparative studies for the anionic series [(μ -RE)(μ -CO)Fe₂(CO)₆][−] (E = S, Se, Te). Now, we have found that anions **3** not only can be prepared as their [Li]⁺ salts, but also as their [MgX]⁺ salts. The preparation of **3**·[MgX] salts, similar to that of **3**·[Li] salts, involved an insertion reaction of elemental Te with Grignard reagents RMgX (R = Et, *t*-Bu, *i*-Bu, Ph, *p*-MeC₆H₄; X = Cl, Br) followed by reaction of the intermediates RTeMgX with Fe₃(CO)₁₂ (Eq. 2). The formation of [MgX]⁺ salts of anion **3** had been also demonstrated by IR spectrum of the THF solution of **3**·[MgX] (R = Ph) showing a medium μ -CO absorption band at 1620 cm^{−1}.

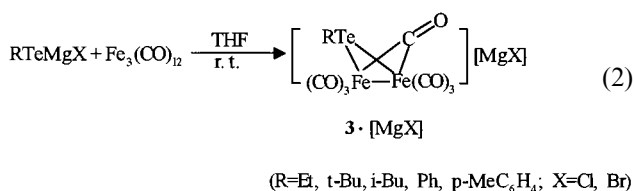

We further found that the in situ reaction of the THF solution of **3**·[MgX] (R = Et, *t*-Bu, *i*-Bu) with the electrophile diphenylacetylene, followed by treatment with excess CF₃COOH, gave doubly-bridged Fe/Te complexes (μ -RTe)(μ - σ , π -PhC=CHPh)Fe₂(CO)₆ (**6a**, R = Et; **6b**, R = *t*-Bu; **6c**, R = *i*-Bu) in 25, 31 and 39% yields, respectively (Scheme 3). The reaction mechanism is similar to that proposed for the reaction of **3**·[Li] with PhC≡CH [3], except that in this case the proton used for protonation of the carbanion intermediates is from the extra added electrophile CF₃COOH (Scheme 3).

Although products **6a–c** might be present theoretically as four isomers [*a*(R)*endo*(H), *e*(R)*endo*(H), *a*(R)*exo*(H) and *e*(R)*exo*(H) (Scheme 4)], they actually exist only as one isomer since the ¹H-NMR spectra of CH₂ in Et of **6a**, CH₂ in *i*-Bu of **6c** and CH₃ in *t*-Bu of **6b** showed only one quartet, one doublet and one singlet, respectively, and those of the HC group in the ligand PhCH=CPh of **6a–c** exhibit only one singlet. It was reported ([1]c) that reactions of **1**·[Et₃NH]⁺ salts with acetylenes also each afforded one isomer product, in which the proton on the C=C double bond lies in an *endo* position and the R group is bonded to S atom in an *equatorial* orientation. Therefore, the type of isomers for products **6a–c** yielded from the similar reaction shown in Scheme 3 would belong to *e*(R)*endo*(H).

While the reaction of anions **1** [5] and **2** (vide supra) with Ph₂AsCl are known to give doubly-bridged Fe/S and Fe/Se compounds of the type (μ -RE)(μ -Ph₂As)Fe₂(CO)₆ (E = S, Se), no study concerning the reaction of anions **3** with Ph₂AsCl are reported so far. Interestingly, we found that the [MgX]⁺ salts of anions **3** (R = Et, *p*-MeC₆H₄) could react also with Ph₂AsCl, under similar conditions to those with anions **1** or **2**, to give the type of products (μ -RTe)(μ -Ph₂As)Fe₂(CO)₆ (**7a**, R = Et, **7b**, R = *p*-MeC₆H₄) in 13 and 18% yields, respectively (Scheme 5). It appears that the nucleophilicity of anions **2** is much greater than that of anions **3**, since the yields of (μ -EtSe)(μ -Ph₂As)Fe₂(CO)₆ (**4**) and (μ -EtTe)(μ -Ph₂As)Fe₂(CO)₆ (**7a**) are 22 and 13%, respectively.

Products **7a,b** like their analogs (μ -RE)(μ -Ph₂As)Fe₂(CO)₆ [E = S [6], Se (vide supra)] exist as only one *e*(R) isomer. This has been demonstrated by their ¹H-NMR spectra, in which TeCH₂ of **7a** showed only

one quartet at 2.78 ppm and the *p*-Me substituent of **7b** exhibited only one singlet at 2.29 ppm, respectively.

We found also that reaction of $3 \cdot [\text{MgX}]$ ($\text{R} = \text{Ph}$, *p*-MeC₆H₄) with *N*-phenylbenzimidoyl chloride, PhC(Cl)=NPh afforded the corresponding Fe/Te complexes **8a,b** and **9a,b** in 21 and 28% yields, respectively (Scheme 5). Products **8a,b** and **9a,b** are two pairs of isomers, in which **8a** and **9a** were assigned to have an *axial* R, whereas **8b** and **9b** were assigned to have an *equatorial* R (Scheme 5), since the ¹H-NMR spectra of the former, compared to those of the latter, appeared in higher field [3]. In addition, the single-crystal X-ray diffraction analysis for **9b** (vide infra) has confirmed further such assignments. The IR spectra of **8a,b** and **9a,b** showed one medium absorption band at 1535–1547 cm⁻¹ for their C=N double bonds, so that the IR spectra of C=N double bonds of **8a,b** and **9a,b** are similar to those of (μ -RS)(μ -R'C=NPh)Fe₂(CO)₆ ($\nu_{\text{C=N}}$ 1555–1570 cm⁻¹) prepared by the Seyferth group ([1]d). This means that the C=N double bond in **8a,b** and **9a,b** might be involved basically in coordination of the nitrogen lone electron pair with iron atom, but not in coordination of the C=N double bond. In fact, this coordination mode of μ -iminoacyl has also been confirmed by the single-crystal X-ray diffraction analysis of **9b** (vide infra). The reaction mechanism for the formation of **7a,b** is obviously the same as that described for the production of **4**, whereas production of **8a,b** and **9a,b** can be viewed, similar to that of (μ -MeS)(μ -PhC=NPh)Fe₂(CO)₆ ([1]d), as through a simple S_N2 process with attack of an iron-centered anion at the imino carbon and subsequent bridging of the iminoacyl ligand by the nitrogen lone electron pair with the concomitant loss of the μ -CO ligand (Scheme 5).

It is worth noting that the nucleophilicity of $3 \cdot [\text{MgX}]$ salts is probably similar to that of $3 \cdot [\text{Li}]$ salts towards PhC=CPh, Ph₂AsCl or PhC(Cl)NPh, since the yield of **8a,b** are comparable in both reactions of *N*-phenylbenzimidoyl chloride with $3 \cdot [\text{MgX}]$ and with $3 \cdot [\text{Li}]$ (21 and

23% yield, respectively). However, since Grignard reagents are generally more readily accessible than lithium reagents, this synthetic route based on $3 \cdot [\text{MgX}]$ salts, compared to that based on $3 \cdot [\text{Li}]$ salts [3], would be more convenient and more applicable in the synthesis of numerous corresponding organometallics.

2.3. Crystal structure of **9b**

In order to confirm the types of structures of **8a,b** and **9a,b**, an X-ray diffraction analysis of **9b** was undertaken. The molecular structure of **9b** is shown in Fig. 1; Table 1 lists its selected bond lengths and angles. As seen in Fig. 1, both *p*-MeC₆H₄Te and PhC=NPh ligands are indeed bridged to two Fe atoms of the two Fe(CO)₃ units; in addition, the *p*-MeC₆H₄ group attached to Te atom lies in an *equatorial* position, whereas the two phenyl groups bonded to a C=N bond are located in a *cis* manner. The C(14)–N bond in μ -iminoacyl ligand of **9b** (1.293(5) Å) could be best assigned to a C=N double bond, but not a C–N single bond, since the normal bond lengths of a C–N single bond and a C=N double bond are 1.47 and 1.28 Å [7], respectively. In fact, such a type of C=N double bond was also observed in other μ -iminoacyl bridged transition metal complexes, such as (μ -H)(μ - η^2 -PhC=NCH₃)Os₃(CO)₁₀ (1.278(10) Å) [8] and (μ -H)(μ - η^2 -HC=NPh)Os₃(CO)₉ (P(OMe)₃) (1.320(10) Å) [9]. It follows that this is consistent with the assignment of its structure (according to IR data) being the nitrogen lone electron pair coordination, but not the C=N double bond coordination. However, in (μ -H)(μ_3 - η^2 -HC=NPh)Os₃(CO)₉ (1.415(1) Å) [9], the C=N double bond is much longer than C(14)–N bond in **9b** and has approached a normal C–N single bond, due to the C=N double bond coordinated to the third Os atom in this triosmium compound.

The Fe(1)–N bond length of **9b** is 1.993(4) Å, which is almost the same as those in (μ -H)(μ_3 - η^2 -

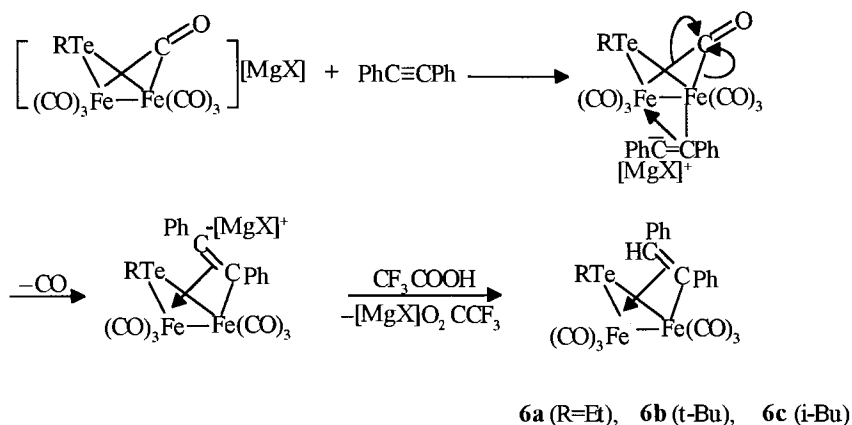

Scheme 3.

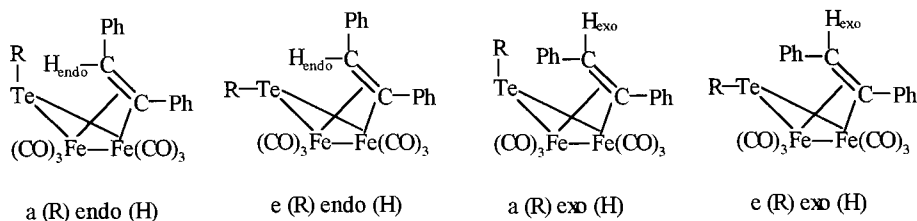

Scheme 4.

$\text{CH}_3\text{C}=\text{NH})\text{Fe}_3(\text{CO})_9$, 2.001(2) Å (Fe(1)–N) and 1.931(2) Å (Fe(2)–N) [10]. The Fe(2)–C(14) bond length (1.985(4) Å) of **9b** is reasonable for the bond length of a σ -bond between an sp^2 -carbon atom and an iron atom of $\text{Fe}(\text{CO})_3$, such as those in $(\mu\text{-PhSe})(\mu\text{-PhCH}_2\text{SC}=\text{S})\text{Fe}_2(\text{CO})_6$ (1.98(1) Å) ([2]a), $(\mu\text{-}t\text{-BuS})(\mu\text{-EtOC}(\text{=CH}_2)\text{C}=\text{O})\text{Fe}_2(\text{CO})_6$ (1.930(3) Å) [11].

In addition, the Fe(1)–Fe(2) bond length of 2.616(1) Å of **9b** is basically the same as those in other similar Fe/Te complexes, such as 2.61(1) Å in $[(\mu\text{-PhTe})\text{Fe}_2(\text{CO})_6]_2(\mu\text{-Te-Te-}\mu)$ [3], 2.614(4) Å in $[(\mu\text{-Te})(\mu\text{-Te})_2\text{Fe}_2(\text{CO})_6]^{-2}$ [12] and 2.634(5) Å in $[(\mu\text{-MeTe})_2\text{Fe}_2(\text{CO})_6]$ [13]. Likewise, the average Fe–Te bond length (2.535 Å) of **9b** agrees well with those in $[(\mu\text{-PhTe})\text{Fe}_2(\text{CO})_6]_2(\mu\text{-Te-Te-}\mu)$ (2.536 Å) [3], $(\mu\text{-MeTe})_2\text{Fe}_2(\text{CO})_6$ (2.549 Å) [13] and $[(\mu\text{-Te})(\mu\text{-Te})_2\text{Fe}_2(\text{CO})_6]^{-2}$ (2.572 Å) [12]. The dihedral angle between the two wings [Fe(1)–Te–Fe(2) and Fe(1)–N–C(14)–Fe(2)] of the butterfly skeleton of **9b** is equal to 82.29°, which is much smaller than those between the two Fe_2Te wings in $[(\mu\text{-PhTe})_2\text{Fe}_2(\text{CO})_6]_2(\mu\text{-Te-Te-}\mu)$ (100.82 and 100.95°) [3] and in $(\mu\text{-MeTe})_2\text{Fe}_2(\text{CO})_6$ (99.66°) [13].

3. Experimental

All reactions were carried out under an atmosphere of prepurified nitrogen using standard Schlenk and vacuum-line techniques. THF was distilled from sodium-benzophenone ketyl under nitrogen. Elemental Se and Te, PhNCS, MeI, CF_3COOH and $\text{PhC}\equiv\text{CPh}$ were chemically pure reagents and were used without further purification. Grignard reagents RMgX [14], $\text{Fe}_3(\text{CO})_{12}$ [15], Ph_2AsCl [16] and $\text{PhC}(\text{Cl})\text{NPh}$ [17] were prepared according to the literature. The products were separated by TLC (20 × 25 × 0.25 cm, silica gel G) and further purified by recrystallization from CH_2Cl_2 /hexane. The yields of the products were calculated based on the electrophiles Ph_2AsCl , PhNCS, $\text{PhC}\equiv\text{CPh}$ and $\text{PhC}(\text{Cl})\text{NPh}$ employed. IR spectra were recorded on a Nicolet FT-IR 170 X spectrophotometer; $^1\text{H-NMR}$ spectra were obtained on either a Jeol FX-90 Q or a Bruker Ac-200 NMR spectrometer. Combustion analyses were performed on a Yanaco CHN Corder MT-3 analyzer and melting points were determined on a Yanaco Mp-500 apparatus.

3.1. Standard in situ preparation of intermediate salts $[(\mu\text{-RSe})(\mu\text{-CO})\text{Fe}_2(\text{CO})_6][\text{MgX}]$ (2**·[MgX]; R = Et, *p*-MeC₆H₄; X = Br)**

A 100 ml three-necked flask equipped with a magnetic stir-bar, a rubber septum and a nitrogen inlet tube was charged with 0.237 g (3.00 mmol) of selenium powder, 30 ml of THF and 3.00 mmol of Grignard reagents RMgX (R = Et, *p*-MeC₆H₄; X = Br) in Et₂O or THF. The mixture was stirred at r.t. for ca. 20 min and at this time the selenium powder completely disappeared to give a yellowish solution. To the solution was added 1.50 g (2.98 mmol) of $\text{Fe}_3(\text{CO})_{12}$ and the mixture was stirred at r.t. for ca. 30 min, resulting in brown–red solutions of salts **2**·[MgX] (R = Et, *p*-MeC₆H₄; X = Br), which were utilized immediately in the following preparations.

3.1.1. Preparation of $(\mu\text{-EtSe})(\mu\text{-Ph}_2\text{As})\text{Fe}_2(\text{CO})_6$ (4**)**

To the above prepared solution of **2**·[MgX] (R = Et, X = Br) was added 0.29 ml (1.51 mmol) of Ph_2AsCl . The reaction mixture was stirred at r.t. for 12 h. Upon cooling to r.t., the mixture was filtered through a ca. 5 cm high bed of 200–300 mesh silica gel to remove insoluble materials. The filtrate was evaporated under reduced pressure to remove all volatiles and then the residue was subjected to TLC separation using 1:20 (v/v) CH_2Cl_2 /petroleum ether as eluent. The first main band gave 0.207 g (28%) of $(\mu\text{-EtSe})_2\text{Fe}_2(\text{CO})_6$, which has been identified by comparison of its m.p. and $^1\text{H-NMR}$ spectrum with those of an authentic sample [18]. The third main band afforded 0.204 g (22%) of **4** as a red solid, m.p. 92–93°C. Anal. Found: C, 38.79; H, 2.20%. $\text{C}_{20}\text{H}_{15}\text{AsFe}_2\text{O}_6\text{Se}$ Calc.: C, 38.93; H, 2.45%. IR (KBr disk): terminal C=O, 2049s, 2016s, 1983vs, 1959vs cm^{-1} . $^1\text{H-NMR}$ (CDCl_3): δ 1.15(t, J = 7.2 Hz, 3H, CH₃), 2.48(q, J = 7.2 Hz, 2H, CH₂), 6.96–7.40(m, 10H, 2C₆H₅) ppm.

3.1.2. Preparation of $(\mu\text{-}p\text{-MeC}_6\text{H}_4\text{Se})(\mu\text{-PhN(Me)CS})\text{Fe}_2(\text{CO})_6$ (5**)**

To the above prepared solution of **2**·[MgX] (R = *p*-MeC₆H₄, X = Br) cooled to –10°C, was added 0.18 ml (1.50 mmol) of PhNCS. The reaction mixture was stirred at –10°C for 0.5 h and then at r.t. for 1 h. After 0.19 ml (3.02 mmol) of MeI was added, the

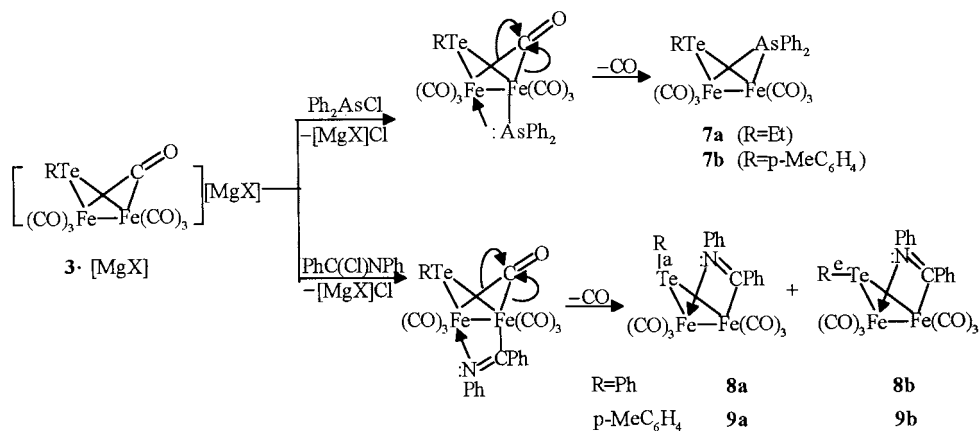

Scheme 5.

reaction mixture was stirred continuously at this temperature for 15 h. After the same workup as that for **4**, the first main band gave 0.182 g (20%) of $(\mu\text{-}p\text{-MeC}_6\text{H}_4\text{Se})_2\text{Fe}_2(\text{CO})_6$, which has been identified by comparison of its m.p. and $^1\text{H-NMR}$ spectrum with those given in literature ([2]a). The second main band afforded 0.318 g (35%) of **5** as a red solid, m.p. 111°C (dec). Anal. Found: C, 42.20; H, 2.67; N, 2.33%. C₂₁H₁₅Fe₂NO₆SSe Calc.: C, 42.03; H, 2.52%; N, 2.33%. IR (KBr disk): terminal C=O, 2063vs, 2022vs, 2004vs, 1975vs cm⁻¹. $^1\text{H-NMR}$ (CDCl₃): 2.25(s, 3H, ArCH₃), 3.55(s, 3H, NCH₃), 6.94–7.50(m, 9H, C₆H₄, C₆H₅) ppm.

3.2. Standard in situ preparation of intermediate salts $[(\mu\text{-}R\text{Te})(\mu\text{-CO})\text{Fe}_2(\text{CO})_6][MgX]$ (**3**·[MgX]; R = Et, *t*-Bu, *i*-Bu, Ph, *p*-MeC₆H₄, X = Cl, Br)

A 100 ml three-necked flask equipped with a magnetic stir-bar, a rubber septum, and a reflux condenser topped with a nitrogen inlet tube was charged with 0.383 g (3.00 mmol) of tellurium powder, 40 ml of THF and 3.00 mmol of RMgX (R = Et, *t*-Bu, *i*-Bu, Ph, *p*-MeC₆H₄; X = Cl, Br) in Et₂O or THF. The mixture was refluxed for 0.5 h (in the cases of aryl Grignard reagents) or 8 h (in the cases of aliphatic Grignard reagents) to give a light gray solution with very small amounts of tellurium powder. Upon cooling the solution to r.t., 1.50 g (2.98 mmol) of Fe₃(CO)₁₂ was added and the reaction mixture was stirred for ca. 0.5 h to produce brown-red solution of salts **3**·[MgX] (R = Et, *t*-Bu, *i*-Bu, Ph, *p*-MeC₆H₄; X = Cl, Br), which was utilized immediately in the following preparations.

3.2.1. Preparation of $(\mu\text{-EtTe})(\mu\text{-}\sigma,\pi\text{-PhC=CHPh})\text{-Fe}_2(\text{CO})_6$ (**6a**)

To the above prepared solution of **3**·[MgX] (R = Et, X = Br) was added, at r.t., 0.267 g (1.50 mmol) of PhC≡CPh. The reaction mixture was stirred at this

temperature for about 12 h and then 0.24 ml (3.12 mmol) of CF₃COOH was added followed by stirring the reaction mixture for an additional 2 h. The same workup as that for **4** was then carried out, except for TLC using neat petroleum ether as eluent. From the first main band 0.270 g (30%) of $(\mu\text{-EtTe})_2\text{Fe}_2(\text{CO})_6$ was obtained as a red oil. Anal. Found: C, 20.27; H,

Fig. 1. Molecular structure of **9b** showing the atom labeling scheme.

Table 1
Selected bond lengths (Å) and bond angles (°) for 9b

Bond length (Å)			
Te–Fe(1)	2.5309(8)	N–C(14)	1.293(5)
Te–Fe(2)	2.539(2)	Fe(1)–C(1)	1.782(5)
Te–C(7)	2.124(4)	Fe(2)–C(4)	1.791(5)
Fe(1)–Fe(2)	2.616(1)	N–C(21)	1.466(5)
Fe(1)–N	1.993(4)	O(1)–C(1)	1.144(6)
Fe(2)–C(14)	1.985(4)	O(4)–C(4)	1.136(7)
Bond angle (°)			
Fe(1)–Te–Fe(2)	62.13(2)	Fe(1)–Fe(2)–C(14)	70.8(1)
Fe(2)–Te–C(7)	107.1(1)	Fe(1)–N–C(21)	126.2(3)
Te–Fe(1)–N	80.4(1)	Fe(2)–C(14)–N	109.4(3)
Fe(2)–Fe(1)–N	70.4(1)	Te–Fe(1)–Fe(2)	59.09(3)
Te–Fe(2)–Fe(1)	58.78(3)	Fe(1)–N–C(14)	109.4(3)
Te–Fe(2)–C(14)	81.0(1)	C(14)–N–C(21)	124.3(3)

1.66%. $C_{10}H_{10}Fe_2O_6Te_2$ Calc.: C, 20.24; H, 1.69%. IR (KBr disk): terminal $C\equiv O$, 2050s, 2009vs, 1972vs cm^{-1} . 1H -NMR ($CDCl_3$): δ 1.21–1.66(m, 6H, CH_3), 2.52–2.64(m, 4H, CH_2) ppm. The third main band gave 0.231 g (25%) of **6a** as a red solid, m.p. 124–125°C. Anal. Found: C, 42.89; H, 2.82%. $C_{22}H_{16}Fe_2O_6Te$ Calc.: C, 42.92; H, 2.62%. IR (KBr disk): terminal $C\equiv O$, 2060s, 2028vs, 1990vs, 1968vs cm^{-1} . 1H -NMR ($CDCl_3$): δ 1.62(t, $J = 7.2$ Hz, 3H, CH_3), 2.83(q, $J = 7.2$ Hz, 2H, CH_2), 3.27(s, 1H, HC=), 6.43–7.23(m, 10H, $2C_6H_5$) ppm.

3.2.2. Preparation of $(\mu-t-BuTe)(\mu-\sigma,\pi-PhC=CHPh)Fe_2(CO)_6$ (**6b**)

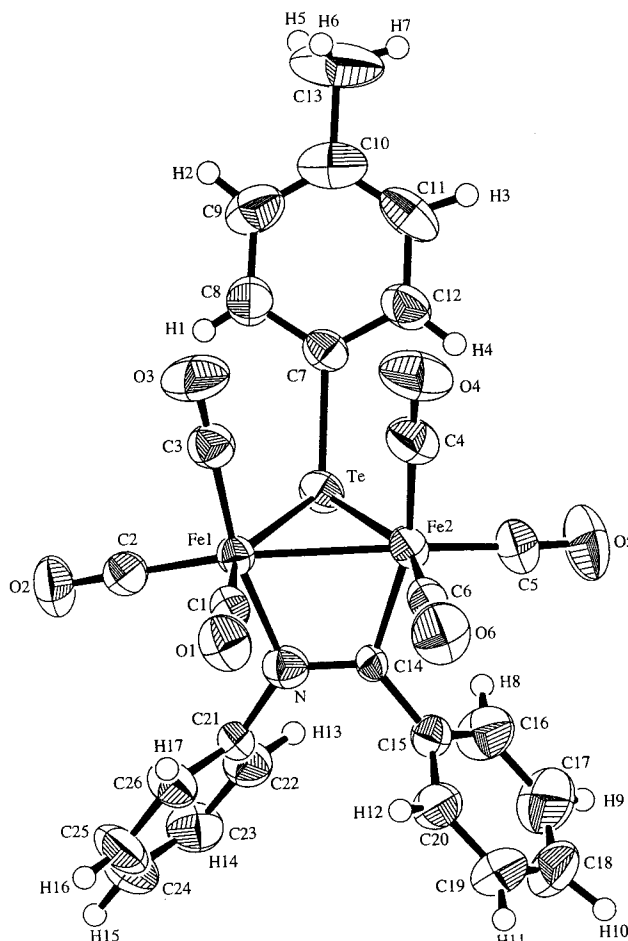
The same procedure as that for **6a** was followed, but a solution of $3 \cdot [MgX]$ ($R = t-Bu$, $X = Cl$) was used instead of the solution of **3** ($R = Et$, $X = Br$). The first main band showed that it consisted of $(\mu-t-BuTe)_2Fe_2(CO)_6$ together with some unconsumed $PhC\equiv CPh$. The third main band afforded 0.297 g (31%) of **6b** as a red solid, m.p. 125–126°C. Anal. Found: C, 44.86; H, 3.06%. $C_{24}H_{20}Fe_2O_6Te$ Calc.: C, 44.78; H, 3.13%. IR (KBr disk): terminal $C\equiv O$, 2051s, 2013vs, 1968vs, 1939s cm^{-1} . 1H -NMR ($CDCl_3$): δ 1.73(s, 9H, $(CH_3)_3C$), 3.60(s, 1H, HC=), 6.56–7.43(m, 10H, $2C_6H_5$) ppm.

3.2.3. Preparation of $(\mu-i-BuTe)(\mu-\sigma,\pi-PhC=CHPh)Fe_2(CO)_6$ (**6c**)

The same procedure as that for **6a** was followed, but a solution of $3 \cdot [MgX]$ ($R = i-Bu$, $X = Br$) was used instead of the solution of $3 \cdot [MgX]$ ($R = Et$, $X = Br$). From the first main band, was obtained 0.225 g (23%) of $(\mu-i-BuTe)_2Fe_2(CO)_6$ as a red oil. Anal. Found: C, 25.81; H, 2.62%. $C_{14}H_{18}Fe_2O_6Te_2$ Calc.: C, 25.90; H, 2.79%. IR (KBr disk): terminal $C\equiv O$, 2083s, 2048vs, 2009vs, 1970vs cm^{-1} . 1H -NMR ($CDCl_3$): δ 0.96–1.40(m, 12H, 4 CH_3), 1.68–2.00(m, 2H, 2CH), 2.44–2.96(m, 4H, 2 CH_2) ppm. The third main band

produced 0.375 g (39%) of **6c** as a red solid, m.p. 102–103°C. Anal. Found: C, 44.52; H, 3.02%. $C_{24}H_{20}Fe_2O_6Te$ Calc.: C, 44.78; H, 3.13%. IR (KBr disk): terminal $C\equiv O$, 2054s, 2022s, 1978vs, 1965vs cm^{-1} . 1H -NMR ($CDCl_3$): δ 1.18(d, $J = 6.0$ Hz, 6H, 2 CH_3), 2.00(m, 1H, CH), 2.87(d, $J = 6.0$ Hz, 2H, CH_2), 3.35(s, 1H, HC=), 6.50–7.44(m, 10H, $2C_6H_5$) ppm.

3.2.4. Preparation of $(\mu-EtTe)(\mu-Ph_2As)Fe_2(CO)_6$ (**7a**)

To the prepared solution of $3 \cdot [MgX]$ ($R = Et$, $X = Br$) was added 0.3 ml (1.50 mmol) of Ph_2AsCl . The mixture was stirred for 8 h at r.t. and for 15 min at reflux. The same procedure as that for **4a** gave the first band, from which 0.267 g (29%) of $(\mu-EtTe)_2Fe_2(CO)_6$ was obtained. From the third band 0.129 g (13%) of red solid **7a** was obtained, m.p. 84–85°C. Anal. Found: C, 36.18; H, 2.15%. $C_{20}H_{15}AsFe_2O_6Te$ Calc.: C, 36.09; H, 2.27%. IR (KBr disk): terminal $C\equiv O$, 2041s, 2008vs, 1959vs cm^{-1} . 1H -NMR ($CDCl_3$): δ 1.36(t, $J = 7.2$ Hz, 3H, CH_3), 2.78(q, $J = 7.2$ Hz, 2H, CH_2), 6.93–7.52(m, 10H, $2C_6H_5$) ppm.

3.2.5. Preparation of $(\mu-p-MeC_6H_4Te)(\mu-Ph_2As)Fe_2(CO)_6$ (**7b**)

The same procedure as that for **7a** was followed, but a solution of $3 \cdot [MgX]$ ($R = p-MeC_6H_4$, $X = Br$) was used instead of the solution of $3 \cdot [MgX]$ ($R = Et$, $X = Br$). From the first main band was obtained 0.384 g (36%) of $(\mu-p-MeC_6H_4Te)_2Fe_2(CO)_6$, which has been identified by comparison of its m.p. and 1H -NMR spectrum with those of an authentic sample [3]. The third main band gave 0.195 g (18%) of **7b** as a red solid, m.p. 110–111°C. Anal. Found: C, 41.40; H, 2.39%. $C_{25}H_{17}AsFe_2O_6Te$ Calc.: C, 41.27; H, 2.35%. IR (KBr disk): terminal $C\equiv O$, 2046s, 2010s, 1982s, 1965vs, 1951vs cm^{-1} . 1H -NMR ($CDCl_3$): δ 2.29(s, 3H, CH_3), 6.80–7.58(m, 14H, C_6H_4 , $2C_6H_5$) ppm.

3.2.6. Preparation of $(\mu-PhTe)(\mu-PhC=NPh)Fe_2(CO)_6$ (**8a,b**)

To the above prepared solution of $3 \cdot [MgX]$ ($R = Ph$, $X = Br$) cooled to ca. $-78^\circ C$, it was transferred slowly by a cannula 0.323 g (1.50 mmol) of $PhC(Cl)=NPh$ in 10 ml of THF (also cooled to $-78^\circ C$) and then the reaction mixture was stirred for 15 min at $-78^\circ C$ and for 12 h at r.t. After the same workup as that for **4**, from the first band was produced 0.495 g (48%) of $(\mu-PhTe)_2Fe_2(CO)_6$, which has been identified by comparison of its m.p. and 1H -NMR spectrum with those of an authentic sample [3]. From second and third bands were afforded 0.057 g (6%) of **8a** and 0.144 g (15%) of **8b**. **8a** and **8b** could be also prepared by using the $3 \cdot [Li]$ ($R = Ph$) salt [3] instead of the $3 \cdot [MgX]$ through the same procedure. The yields of $(\mu-PhTe)_2Fe_2(CO)_6$, **8a** and **8b** are 0.433 (41), 0.076 (8) and 0.144 g (15%), respectively. Isomers **8a** and **8b** are red solids.

Table 2
Crystal data and experimental details for 9b

Formula	C ₂₆ H ₁₇ Fe ₂ NO ₆ Te
Formula weight	678.72
Crystal system	Monoclinic
Space group	P2 ₁ /c (no. 14)
a (Å)	16.493(3)
b (Å)	8.467(3)
c (Å)	19.100(5)
β (°)	90.78(2)
V (Å ³)	2666(1)
Z	4
D _{calc.} (g cm ⁻³)	1.690
F(000)	1328.00
μ(Mo–K _α) (cm ⁻¹)	21.99
Diffractometer	Rigaku AFC7R
Temperature (°C)	20.0
Radiation (Å)	Mo–K _α (λ = 0.71069)
Scan type	ω – 2θ
2θ _{max} (°)	50.0
No. of observed reflections, n	3324
No. of variables, p	326
R	0.031
R _w	0.040
Goodness-of-fit indicator	1.68
Max shift in final cycle	0.00
Largest peak (e Å ⁻³)	0.51

8a: m.p. 180° (dec). Anal. Found: C, 45.16; H, 2.14; N, 2.15%. C₂₅H₁₅Fe₂NO₆Te Calc.: C, 45.17; H, 2.27; N, 2.11%. IR (KBr disk): terminal C=O, 2058vs, 2015vs, 1986vs, 1964s cm⁻¹; C=N 1535m cm⁻¹. ¹H-NMR (CDCl₃): δ 5.93–7.57(m, 15H, 3C₆H₅) ppm.

8b: m.p. 133°C (dec). Anal. Found: C, 45.02; H, 2.15; N, 1.98%. C₂₅H₁₅Fe₂NO₆Te Calc.: C, 45.17; H, 2.27; N, 2.11%. IR (KBr disk): terminal C=O, 2061vs, 2015vs, 1987vs, 1966s cm⁻¹; C=N 1536m cm⁻¹. ¹H-NMR (CDCl₃): δ 6.51–7.58(m, 15H, 3C₆H₅) ppm.

3.2.7. Preparation of

(μ-*p*-MeC₆H₄Te)(μ-PhC=NPh)Fe₂(CO)₆ (**9a,b**)

The same procedure as that for **8a,b** was followed, but a solution of 3·[MgX] (R = *p*-MeC₆H₄, X = Br) was used in place of the solution of 3·[MgX] (R = Ph, X = Br). The first band gave 0.449 g (41%) of (μ-*p*-MeC₆H₄Te)₂Fe₂(CO)₆ [3]. The second and third bands afforded 0.090 g (9%) of **9a** and 0.192 g (19%) of **9b**, both isomers as red solids.

9a: m.p. 164°C (dec). Anal. Found: C, 45.89; H, 2.66; N, 2.18%. C₂₆H₁₇Fe₂NO₆Te Calc.: C, 46.01; H, 2.52; N, 2.06%. IR (KBr disk): terminal C=O, 2058s, 2017vs, 1997vs, 1978s cm⁻¹; C=N 1544m cm⁻¹. ¹H-NMR (CDCl₃): δ 2.32(s, 3H, CH₃), 5.95–7.44(m, 14H, C₆H₄, 2C₆H₅) ppm.

9b: m.p. 142°C (dec). Anal. Found: C, 45.95; H, 2.57; N, 2.15%. C₂₆H₁₇Fe₂NO₆Te Calc.: C, 46.01; H, 2.52; N, 2.06%. IR (KBr disk): terminal C=O, 2060s, 2010vs, 1987vs, 1967vs cm⁻¹; C=N 1547m cm⁻¹. ¹H-NMR

Table 3
The positional parameters and temperature factors for non-hydrogen atoms of **9b**

Atom	x	y	z	B _{eq}
Te(0)	0.81508(2)	0.13396(3)	0.52791(1)	3.375(8)
Fe(1)	0.67111(4)	0.17841(7)	0.48476(3)	2.95(1)
Fe(2)	0.77695(4)	0.40858(8)	0.48539(3)	3.31(1)
O(1)	0.5398(2)	0.3810(4)	0.4329(2)	5.15(9)
O(2)	0.5762(2)	−0.0962(4)	0.5304(2)	5.46(10)
O(3)	0.7047(3)	0.0433(5)	0.3464(2)	6.6(1)
O(4)	0.8272(3)	0.3590(5)	0.3408(2)	7.2(1)
O(5)	0.9225(3)	0.5740(6)	0.5368(3)	7.9(1)
O(6)	0.6727(3)	0.6661(5)	0.4356(2)	6.3(1)
N(0)	0.6668(2)	0.2932(4)	0.5758(2)	3.76(9)
C(1)	0.5918(3)	0.3025(5)	0.4525(2)	3.4(1)
C(2)	0.6144(3)	0.0086(6)	0.5134(2)	3.6(1)
C(3)	0.6924(3)	0.0948(6)	0.3998(3)	4.2(1)
C(4)	0.8094(3)	0.3739(6)	0.3976(3)	4.8(1)
C(5)	0.8652(3)	0.5113(6)	0.5178(3)	4.8(1)
C(6)	0.7130(3)	0.5652(6)	0.4557(3)	4.0(1)
C(7)	0.8879(3)	0.0300(5)	0.4494(2)	3.43(10)
C(8)	0.8731(3)	−0.1218(6)	0.4259(3)	4.6(1)
C(9)	0.9246(4)	−0.1898(7)	0.3783(3)	5.8(2)
C(10)	0.9885(4)	−0.1110(8)	0.3512(3)	5.5(2)
C(11)	1.0036(3)	0.0401(8)	0.3747(3)	5.4(1)
C(12)	0.9540(3)	0.1106(6)	0.4241(3)	4.6(1)
C(13)	1.0424(5)	−0.184(1)	0.2966(3)	9.6(2)
C(14)	0.7183(2)	0.4084(4)	0.5755(2)	2.41(t)
C(15)	0.7257(3)	0.5286(5)	0.6294(2)	3.37(10)
C(16)	0.7927(4)	0.5371(7)	0.6715(3)	5.6(1)
C(17)	0.8004(5)	0.6607(9)	0.7189(3)	7.3(2)
C(18)	0.7429(5)	0.7744(8)	0.7238(3)	6.9(2)
C(19)	0.6757(4)	0.1657(7)	0.6816(3)	6.2(2)
C(20)	0.6664(3)	0.6423(6)	0.6345(3)	4.6(1)
C(21)	0.6162(3)	0.2519(5)	0.6356(2)	3.07(9)
C(22)	0.6522(3)	0.2108(6)	0.6990(2)	4.3(1)
C(23)	0.6051(4)	0.1563(7)	0.7534(2)	5.1(1)
C(24)	0.5223(4)	0.1466(7)	0.7454(3)	5.6(2)
C(25)	0.4869(3)	0.1910(8)	0.6837(3)	5.8(2)
C(26)	0.5329(3)	0.2417(6)	0.6280(2)	4.5(1)

(CDCl₃): δ 2.32(s, 3H, CH₃), 6.53–7.45(m, 14H, C₆H₄, 2C₆H₅) ppm.

3.3. Single crystal structure determination of **9b**

Single crystals of **9b** suitable for X-ray diffraction were grown from its CH₂Cl₂/hexane solution at −20°C. A crystal measuring 0.20 × 0.20 × 0.30 mm was mounted on a glass fiber and placed on a Rigaku AFC7R diffractometer with graphite monochromator with graphite-monochromated Mo–K_α radiation (λ = 0.71069 Å) and a 12 kW rotating anode generator. A total of 4335 independent reflections were collected at 20°C by the ω – 2θ scan mode, of which 3324 independent reflections I ≥ 3σ(I) were considered to be observed and used in subsequent refinement. The data were corrected for Lorentz polarization factors. Crystal data are listed in Table 2. Table 3 lists the positional parameters and temperature factors for non-H atoms.

The structure was solved by direct methods and expanded using Fourier techniques. The non-hydrogen atoms were refined anisotropically, and H atoms were included but not refined. The final refinement by a full-matrix least-squares method for non-H atoms converged to give the unweighted and weighted agreement factors of 0.031 (R) and 0.040 (R_w). The highest peak on the final difference Fourier map has a height of $0.51 \text{ e } \text{Å}^{-3}$. All calculations were performed using the TEXSAN program system crystallographic software of the Molecular Structure Corporation.

Acknowledgements

We are grateful to the National Natural Science Foundation of China, the Laboratory of Organometallic Chemistry and the State Key Laboratory of Structural Chemistry for financial support of this work.

References

- [1] (a) D. Seyferth, G.B. Womack, C.M. Archer, J.C. Dewan, *Organometallics* 8 (1989) 430. (b) D. Seyferth, G.B. Womack, C.M. Archer, J.P. Fackler Jr., D.O. Marler, *Organometallics* 8 (1989) 443. (c) D. Seyferth, J.B. Hoke, G.B. Womack, *Organometallics* 9 (1990) 2662. (d) D. Seyferth, J.B. Hoke, *Organometallics* 7 (1988) 524.
- [2] (a) L.-C. Song, C.-G. Yan, Q.-M. Hu, R.-J. Wang, T.C.W. Mak, *Organometallics* 14 (1995) 5513. (b) L.-C. Song, C.-G. Yan, Q.-M. Hu, R.-J. Wang, T.C.W. Mak, X.-Y. Huang, *Organometallics* 15 (1996) 1535. (c) L.-C. Song, C.-G. Yan, Q.-M. Hu, B.-M. Wu, T.C.W. Mak, *Organometallics* 16 (1997) 632.
- [3] L.-C. Song, C.-G. Yan, Q.-M. Hu, X.-Y. Huang, *Organometallics* 16 (1997) 3769.
- [4] L.-C. Song, C.-G. Yan, Q.-M. Hu, R.-J. Wang, H.-G. Wang, *Acta Chim. Sin.* 53 (1995) 402.
- [5] L.-C. Song, et al., unpublished work.
- [6] L.-C. Song, R.-J. Wang, Y. Li, H.-G. Wang, J.-T. Wang, *Acta Chim. Sin.* 48 (1990) 867.
- [7] Special Publication: Chem. Soc. (1965) No. 18—C. Sandorfy, in: S. Patai (Ed.), *The Chemistry of the Carbon Nitrogen Double Bond*, Wiley, New York, 1970, Ch. 1.
- [8] R.D. Adams, N.M. Golembeski, *Inorg. Chem.* 17 (1978) 1969.
- [9] R.D. Adams, N.M. Golembeski, *J. Am. Chem. Soc.* 101 (1979) 2579.
- [10] M.A. Andrews, G. van Buskirk, C.B. Knobler, H.D. Kaesz, *J. Am. Chem. Soc.* 101 (1979) 7245.
- [11] D. Seyferth, J.B. Hoke, J.C. Dewan, P. Hofmann, M. Schnellbach, *Organometallics* 13 (1994) 3452.
- [12] B.W. Eichhorn, R.C. Haushalter, J.S. Merola, *Inorg. Chem.* 29 (1990) 728.
- [13] R.E. Bachman, K.H. Whitmire, *Organometallics* 12 (1993) 1989.
- [14] H. Gilman, E.A. Zoellner, J.B. Dickey, *J. Am. Chem. Soc.* 51 (1929) 1576.
- [15] R.B. King, *Organometallic Syntheses*, vol. 1, Transition-Metal Compounds, Academic Press, New York, 1965, p. 95.
- [16] A.B. Bruker, N.M. Nikiforova, *Zhur. Obshechi. Khim.* 28 (1958) 2407.
- [17] W.R. Vaughan, R.D. Carlson, *J. Am. Chem. Soc.* 84 (1962) 769.
- [18] P. Rosenbush, N. Welcman, *J. Chem. Soc. Dalton Trans.* (1972) 1963.