

Review

Novel and selective α -substitution of ketones and other carbonyl compounds based on Pd-catalyzed cross coupling of α,β -unsaturated carbonyl derivatives containing α -halogen or α -metal groups[☆]

Ei-ichi Negishi *

Department of Chemistry, Purdue University, West Lafayette, 49707 IN, USA

Received 1 September 1998

Abstract

The Pd-catalyzed cross coupling of either α -haloenones with organometals or α -metalloenones with organic halides is intrinsically more problematical than the corresponding reaction of β -substituted enones or ordinary alkenyl derivatives. Nonetheless, satisfactory procedures have been developed for cross coupling with organometals containing Zn, Sn, B and Cu to give α -organyleneones in high yields. As in the other cases, organozincs generally display the highest reactivity. In highly demanding and/or delicate situations, some indirect protocols involving protection of carbonyl groups or their temporary reduction help overcome difficulties encountered in direct α -substitution. Conjugate reduction and conjugate addition of α -substituted enones provide the corresponding saturated carbonyl compounds in completely regiocontrolled manner. Together with the ability to accommodate unsaturated organic groups, such as aryl, alkenyl, and alkynyl, the new Pd-catalyzed α -substitution protocols developed since 1987 promise to become synthetic tools of widespread application. © 1999 Elsevier Science S.A. All rights reserved.

Keywords: α -Substitution of carbonyl compounds; Pd-catalyzed cross coupling; α -Halo- α,β -unsaturated carbonyl compounds; α -Metallo- α,β -unsaturated carbonyl compounds

1. Introduction

1.1. Objective

Introduction of simple hydrocarbon groups in the α -position of ketones and other carbonyl compounds is most typically achieved by alkylation of enolates and related compounds [1]. As basic and important as it is, it has been associated with some limitations and undesirable features. Firstly, the alkali and alkaline earth

metal-based methodology is limited to the introduction of sp^3 carbon groups of relatively low steric requirements, such as Me, primary alkyl, allyl, benzyl, and propargyl groups. Introduction of sterically hindered groups, such as tertiary alkyl and many secondary alkyl groups, is not practical, and sp^2 and sp carbon groups, such as aryl, alkenyl, and alkynyl groups, cannot be introduced. Secondly, the reaction is prone to multiple substitution, and it is often difficult to achieve clean monosubstitution. Thirdly, although so called 'kinetic' and 'thermodynamic' enolates can be selectively generated in a number of cases, strict regiochemical control requires special procedures, such as generation of enolates via conjugate reduction of α,β -unsaturated enones, which must then be followed by regiospecific alkylation.

[☆] This paper is dedicated to Professors Jiro Tsuji and Richard F. Heck in recognition of their pioneering works in the area of organopalladium chemistry.

* Fax: +1-7650494-0239.

E-mail address: negishi@chem.purdue.edu (E.-i. Negishi)

Despite all these difficulties and limitations, α -substitution of carbonyl compounds is a highly desirable synthetic operation. *Critically needed is a methodology permitting introduction of all types of carbon groups, especially, aryl, alkenyl, and alkynyl groups with strict control of the degree of substitution and regiochemistry.* To this end, we chose to develop a novel and highly selective methodology based on Pd- or Ni-catalyzed cross coupling of either α -halo- α,β -unsaturated carbonyl compounds or the corresponding α -metallo derivatives. A few representative enone-based α -substitution methodologies are shown in Scheme 1.

In this account, the α -haloenone-based methodology involving Pd-catalyzed cross coupling is presented. As is clear from Scheme 1, direct α -substitution of enones represents an ultimately satisfactory methodology. However, no such methodology of general applicability has as yet been developed. In the meantime, development of the α -haloenone-based methodology requiring at least one additional step may be justified if it leads to high selectivity, high product yields, and other synthetically desirable features that can more than offset the requirement for extra steps. Equally significant is that, in cases where α -substituted enones are the desired products, the α -haloenone-based methodology may provide one of the ultimately satisfactory efficient routes to such products.

1.2. Brief summary of related methodologies

Over the past 25 years or so, a number of attempts to promote α -arylation, α -alkenylation, and α -alkynylation of carbonyl compounds via direct α -substitution of enolates have been made, and some successful results have been observed along with various limitations and difficulties. α -Arylation of potassium enolates in NH_3 via $S_{\text{RN}}1$ process [2] appears to be a reasonable method which has been applied to the synthesis of some complex natural products, such as cephalotoxinone [3]. However, this method does not appear to be readily adaptable to selective α -alkenylation. α -Arylation of

ketones catalyzed by Ni [3] and Pd [4,5] also appears to be reasonably satisfactory. In particular, recent modifications of the Pd-catalyzed arylation using bidentate phosphines [6,7] have yielded some very satisfactory results. Here again, however, the corresponding α -alkenylation [5b,8] has been much more problematical, and satisfactory results have been observed mainly with methyl ketones. Furthermore, the critical issue of α -versus α' -substitution in non-obvious cases has been largely ignored in the studies mentioned above. Further development is clearly needed before its widespread application. Related Ni- and Pd-catalyzed α -arylation and α -alkenylation of ester enolates containing Li [9] and Zn [10] have also yielded reasonably satisfactory results, but their synthetic scopes remain to be further investigated. It should also be noted that, in these reactions and Pd-catalyzed α -arylation of 1,3-diketones [11,12], regioselectivity is not an issue. Although none of the above-mentioned methods has been applied to α -alkynylation, organolead-based α -substitution of β -ketoesters [13] has been applied to α -alkynylation [14]. The reaction of lithium enolates with chloroalkynes also gives α -alkynyl ketones [15], but its applicability appears to be limited to α -alkynylation of ketones containing an α -methine group.

Although space limitation does not permit elaboration, there are a number of more indirect methods of α -substitution including the reaction of organoboranes with enolates derived from α -haloketones [16], α -arylation via bismuth enolates [17], the reaction of arylcoppers with α -bromoketone derivatives [18], α -alkenylation of ketone enolates with enol ether–iron complexes [19], α -selenylaldehydes [20], and α -silylaldehydes [21], and reductive rearrangement of alkynyl halohydrins [22]. There also are various enone-based α -substitution methods [23] permitting distinction between the α and α' positions of ketones, and some of them have been applied to α -arylation [24], α -alkenylation [24], and α -alkynylation [15]. While many of these methods appear to be promising, their applications have thus far been limited to the syntheses of simple

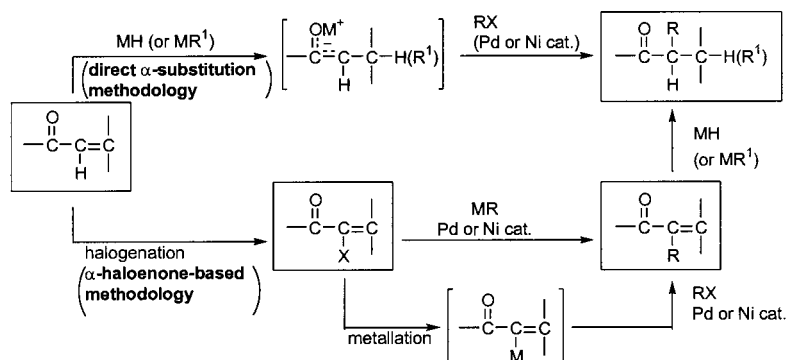

Scheme 1.

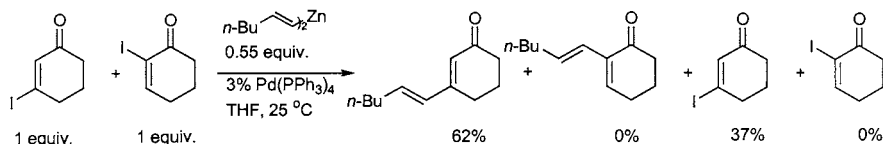

Scheme 2.

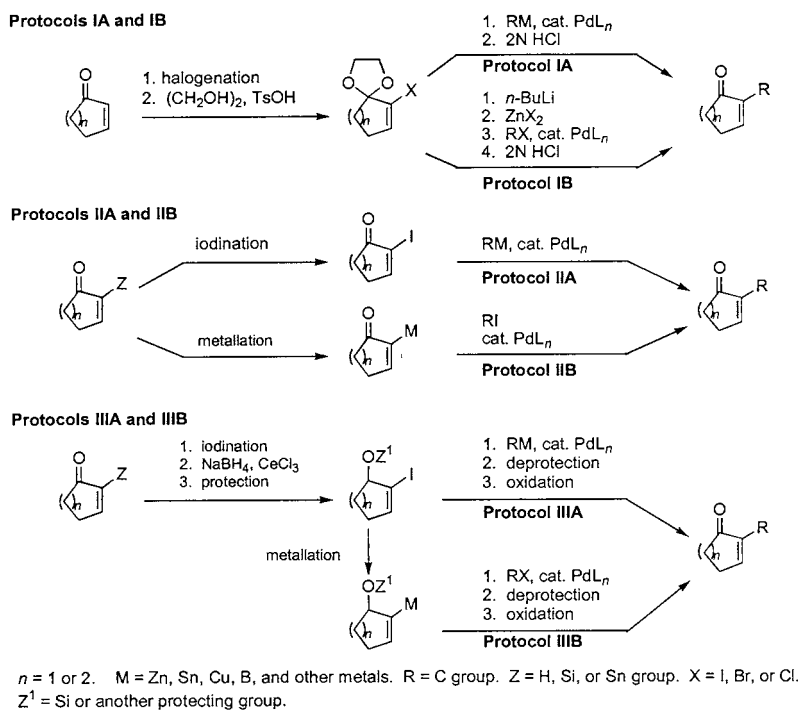

Scheme 3.

model compounds, and their true synthetic scopes remain to be delineated.

2. α -Haloenone-based methodology for α -substitution of carbonyl compound via Pd-catalyzed cross coupling

2.1. Some synthetic protocols to be developed

With the goal of developing a selective synthetic protocol for α -substitution of carbonyl compounds via Pd-catalyzed cross coupling, we initially generated cyclopentenolates containing Zn [25], Sn [4,5], and B [26] and reacted them with *p*-tolyl iodide and (*E*)-1-octenyl iodide as two representative unsaturated iodides in the presence of 5 mol% of $\text{Pd}(\text{PPh}_3)_4$, $\text{Cl}_2\text{Pd}(\text{PPh}_3)_2$, and $\text{Cl}_2\text{Ni}(\text{PPh}_3)_2$ in THF. However, none of these reactions gave the desired α -substituted cyclopentanones in more than 30% yields, typical yields being < 10% [27]. Although disappointing, the results were not surprising in view of the previously documented difficulties observed with cyclohexenolate derivatives [4,5]. Turning our attention to some indirect approaches, the reaction

of 2-bromo-2-cyclohexenone and 2-iodo-2-cyclohexenone with bis[(*E*)-1-hexenyl]zinc in the presence of 5 mol% of a Pd– PPh_3 complex was carried out in THF at 25°C. No desired product was obtained from 2-bromo-2-cyclohexenone even though all of it was consumed. The reaction of 2-iodo-2-cyclohexenone did produce 2-[(*E*)-1-hexenyl]-2-cyclohexenone in 31% yield [28], but the rest of the starting iodoenone had been consumed. In sharp contrast, the corresponding reaction of 3-bromo-2-cyclohexenone gave 3-[(*E*)-1-hexenyl]-2-cyclohexenone in 75% yield, with the balance of the starting bromoenone still remaining unreacted. The sluggish nature of α -substitution and the greater instability of α -haloenones are clearly indicated in the competitive experiment summarized in Scheme 2 [28].

In principle, a number of related but different protocols for α -substitution of enones via Pd-catalyzed cross coupling are conceivable, and several such protocols summarized in Scheme 3 appeared to deserve special attention. For the sake of simplicity, α -substitution of 2-cyclopentenones and 2-cyclohexenones are shown as representative cases.

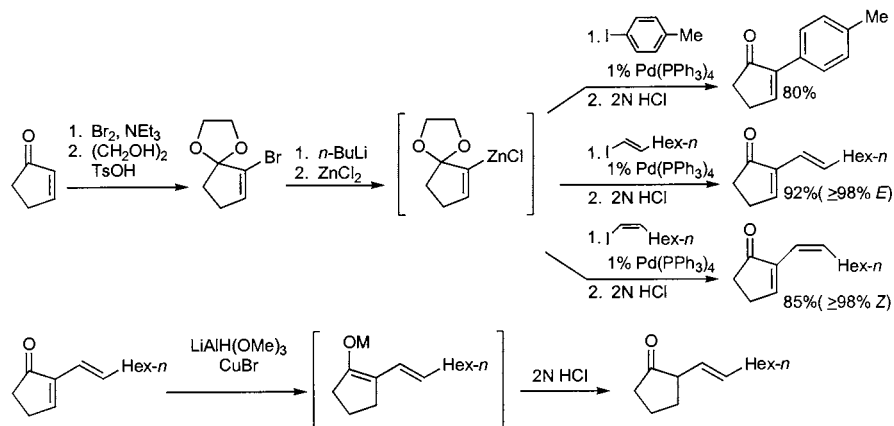

Scheme 4.

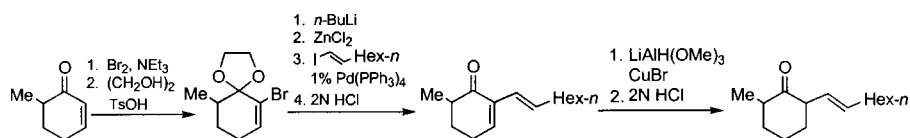

Scheme 5.

Table 1
Effects of reaction parameters in the Pd-catalyzed reaction of 2-iodo-2-cyclopentenone with (*E*)-1-hexenylmetals^a

M-CH=CH-Bu-n	Pd Catalyst ^b	Solvent	Temp. (°C)	Time (h)	Product Yield (%) ^c
Zn(CH=CH-Bu-n) ₂	I	THF	25	1	31
Zn(CH=CH-Bu-n) ₂	I	THF-DMF	25	1	87
Zn(CH=CH-Bu-n) ₂	I	DMF	25	1	100 (86 ^d)
Zn(CH=CH-Bu-n) ₂	II	DMF	25	1	88
Zn(CH=CH-Bu-n) ₂	I	DMSO	25	1	80
Zn(CH=CH-Bu-n) ₂	I	NMP	25	1	74
Me ₂ Al-CH=CH-Bu-n	I	DMF	25	1	71
<i>i</i> -Bu ₂ Al-CH=CH-Bu-n	I	DMF	25	1	89
<i>i</i> -Bu ₂ Al-CH=CH-Bu-n ^e	I	DMF	25	1	44
ClCp ₂ Zr-CH=CH-Bu-n ^e	I	DMF	25	1	27
Bu ₃ Sn-CH=CH-Bu-n	I	DMF	25	1	trace
Bu ₃ Sn-CH=CH-Bu-n	I	DMF	60-65	13	64 ^f

^a The alkenylmetals were prepared by treatment of (*E*)-1-hexenyllithium with appropriate metal halides, unless otherwise mentioned.

^b I = Cl₂Pd(PPh₃)₂ + 2*n*-BuLi. II = Pd(PPh₃)₄.

^c By ¹H-NMR and/or GLC.

^d Isolated yield.

^e Prepared by appropriate hydrometallation of 1-hexyne.

^f 2-Iodo-2-cyclopentenone remained unreacted to the extent of 18%.

2.2. Pd-Catalyzed α -arylation and α -alkenylation of acetal-protected enone derivatives (Protocol I)

In view of the low intrinsic reactivity and high instability of α -haloenones in the Pd-catalyzed cross coupling discussed earlier, we adopted a highly precautionary measure and chose acetal-protected α -bromo enones [29] as key intermediates. Our notion was to exploit the previously developed Pd-catalyzed alkenyl–alkenyl and alkenyl–aryl cross coupling methodologies [30] as fully as possible in the development of Pd-catalyzed α -substitution of carbonyl compounds. The Pd-catalyzed cross-coupling reaction of α -bromo enones with organozincs and other organometals was quite sluggish. On the other hand, their conversion to the corresponding zinc derivatives via lithiation with butyllithium permitted clean and high-yield cross coupling not only with aryl halides but, more significantly, with both *E* and *Z* alkenyl iodides using 1 mol% of Pd(PPh₃)₄ (Scheme 4) [27]. The corresponding alkenyllithiums were totally ineffective under comparable conditions. Conjugate reduction of 2-[(*E*)-

1-octenyl]-2-cyclopentenone with LiAlH(OMe)₃ and CuI [31] followed by protonolysis with 2N HCl at 0°C cleanly provided 2-[(*E*)-1-octenyl]cyclopentanone in excellent yield. Thus, the putative dienolate intermediate must have undergone exclusive α protonation. Full retention of the regiochemistry is clearly indicated in the exclusive formation of 2-[(*E*)-1-octenyl]-6-methylcyclohexanone from 6-methyl-2-cyclohexenone in 55% overall yield (Scheme 5) [27].

Although the feasibility, dependability, and highly selective nature of Protocol IB have been firmly established by the results shown in Schemes 4 and 5, it is nonetheless cumbersome. So, we decided to explore other more efficient protocols, such as Protocols IIA and IIB, rather than further develop Protocol IB.

2.3. Pd-Catalyzed α -arylation and α -alkenylation of α -iodoenones (Protocol IIA)

As discussed earlier, direct α -substitution of α -bromo enones with organozincs and other organometals catalyzed by Pd or Ni complexes appeared very prob-

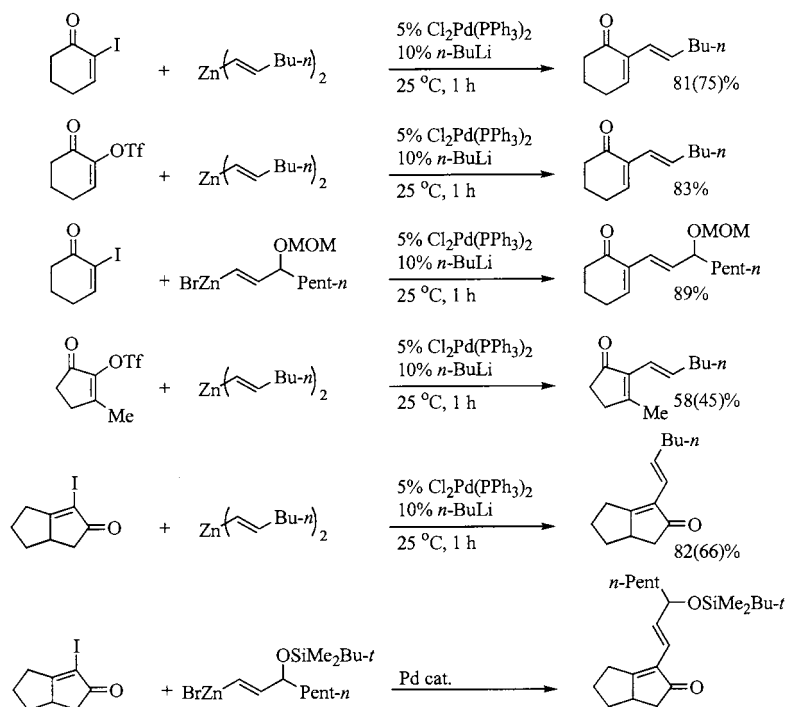



Pd Cat.	Solv.	Temp.(°C)	Time (h)	Yield (%)
Cl ₂ Pd(PPh ₃) ₂ + 2 <i>n</i> -BuLi	DMF	25	1	13
Pd(dba) ₂ + 2 P(2-furyl) ₃	THF	50	24	<5
Pd(dba) ₂ + 2 P(2-furyl) ₃	DMF	20	3	87 (75)

Note: The yields are determined by NMR and/or GLC.
The numbers in parentheses are isolated yields.

Scheme 6.

Table 2

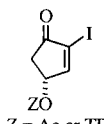
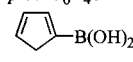
Pd-catalyzed reaction of α -arylation and α -alkenylation of α -iodoenones with organotin and organoboranes^a

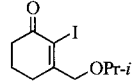
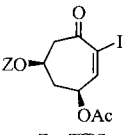
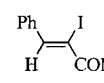
α -Iodoenone	Organometal	Catalyst ^d	Solvent	Temp.(°C)	Product Yield (%)	Ref.
 Z = Ac or TBS	CH ₂ =CHSnBu ₃	I	NMP	25	80	[33]
	Me ₂ C=CHSnBu ₃	I	NMP	80	76	[33]
	<i>p</i> -MeC ₆ H ₄ SnBu ₃	I	NMP	50	66	[33]
	 B(OH) ₂	II	THF	25	97	[34]
	Me ₂ C=CHSnBu ₃	I	NMP	110	83	[33]
	<i>p</i> -MeC ₆ H ₄ B(OH) ₂	II	THF	25	78	[34]
	<i>m</i> -TBSOC ₆ H ₄ SnBu ₃	III	NMP	70	81	[35]
 Z = TIPS	Me ₂ C=CHSnBu ₃	I	NMP	80	80	[33]
	<i>p</i> -MeC ₆ H ₄ SnBu ₃	I	NMP	60	95	[33]
	<i>p</i> -MeC ₆ H ₄ B(OH) ₂	II	THF	25	100	[34]
	CH ₂ =CHSnBu ₃	I	NMP	35-50	47-65	[33,36]
	<i>p</i> -MeC ₆ H ₄ SnBu ₃	I	NMP	85	87	[33]

^a I = 5 mol% Cl₂Pd(PhCN)₂, 10 mol% Ph₃As, 10 mol% CuI. II = 3 mol% Cl₂Pd(PhCN)₂, 6 mol% Ph₃As, 1.6 equivalents Ag₂O. III = Pd₂(dba)₃·CHCl₃, Ph₃As, CuI.

lematical. Despite rather poor results observed in the reaction of 2-iodo-2-cyclohexenone with bis[(*E*)-1-hexenyl]zinc in the presence of a Pd catalyst (5 mol%) generated by the treatment of Cl₂Pd(PPh₃)₂ with two equivalents of *n*-BuLi in THF, we decided to optimize its reaction conditions. It was soon found that the use of polar aprotic solvents would significantly improve the product yield. Thus, the use of DMF, DMSO, and NMP (*N*-methylpyrrolidone) improved the cross coupling yield to ≥ 88 , 80 and 74%, respectively. This investigation has proved to be a major breakthrough in the development of Protocol IIA. (*E*)-1-Hexenyldialkylaluminums prepared by treating (*E*)-1-hexenyllithium with ClAlMe₂ and ClAl(Bu-*i*)₂ were also satisfactory producing the desired product in 71 and 89% yields, respectively, whereas alkenylaluminums generated by hydroalumination were less effective. Also unsatisfactory was the corresponding zirconocene derivative which led only to a 27% yield of the desired product. The *n*-Bu₃Sn-containing reagent was practically unreactive at room temperature, but it gave the desired product in 64% yield in 13 h at 60–65°C. These results of reaction conditions optimization are summarized in Table 1 [28]. In summary, the use of organozinc reagents and DMF as a solvent appear to be optimal. In most cases, Cl₂Pd(PPh₃)₂ and Pd(PPh₃)₄ are satisfactory catalysts. In some more demanding cases, however, the use of more effective catalysts, *e.g.* Cl₂Pd[P(2-

furyl)]₃ [32], has been shown to be desirable (Scheme 6) [28].

As indicated in Table 1, organotin are considerably less reactive than organozincs, but their reactions proceeds satisfactorily in many cases at elevated temperatures, typically around 100°C [33]. Under those conditions that are satisfactory for organozincs, the corresponding organoboron compounds show little reactivity [28]. However, the use of Ph₃As as a ligand together with an excess of Ag₂O (1.5–6.0 equivalents relative to the substrates) permits facile α -arylation in THF even at 25°C [34]. Some representative results observed with organotin [33,35,36] and organoborons [34] are summarized in Table 2. The organotin-based method has been applied to the synthesis of (–)-methyl shikimate [37] and (±)-epibatidine [38] (Scheme 7).

2.4. Pd-Catalyzed α -alkynylation of α -iodoenones (Protocol IIA)

Discovery of natural products of various potentially significant biological activities featuring α -alkynylenones within the last decade prompted the development of procedures for α -alkynylation of enones that might be more direct and more satisfactory than those discussed earlier [14,15]. Several independent studies have shown that applications of the methods for

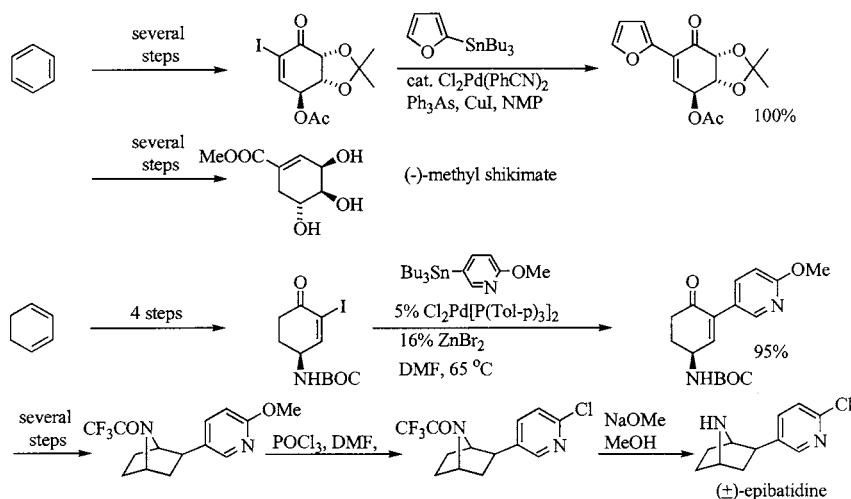

Scheme 7.

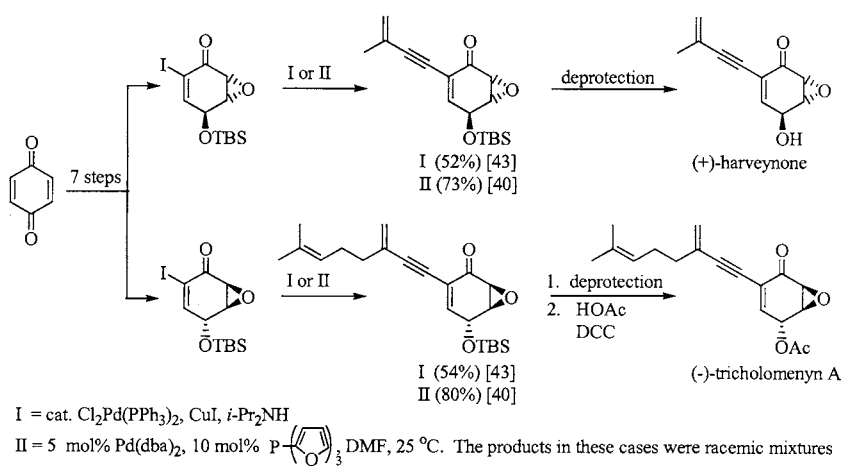

Scheme 8.

α -arylation and α -alkenylation discussed above involving Sn [39] and Zn [40] permit the desired α -alkynylation in good yields. The Cu-based Sonogashira alkylation was reported in one study to be unsatisfactory for the synthesis of tricholomenyn A [41], but some other studies have shown that satisfactory results may be obtained using this reaction [42,43]. These

procedures have been applied to very efficient synthesis of harveynone and tricholomenyn A (Scheme 8) [40,41,43]. Since their synthesis does not require subsequent conjugate reduction, these recently reported syntheses appear to represent some ultimately satisfactory constructions of this class of compounds. Some other results of α -alkynylation are shown in Schemes 9–11.

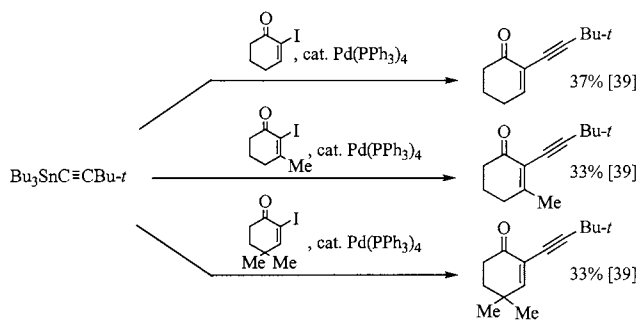

Scheme 9.

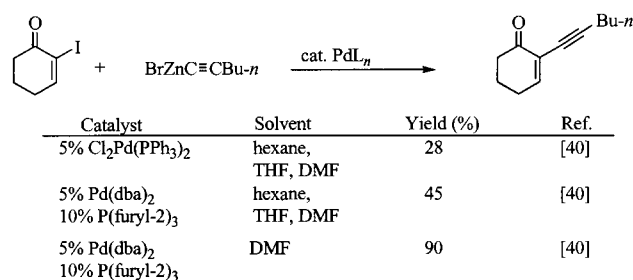

Scheme 10.

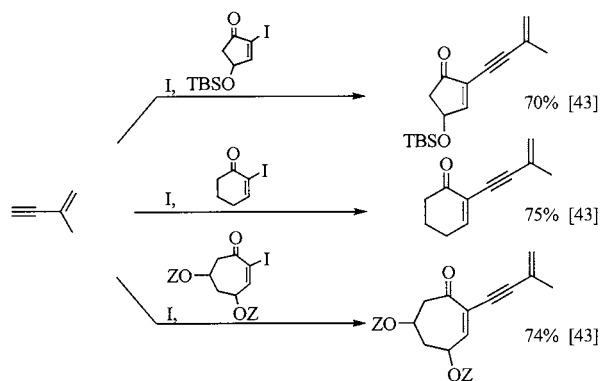

I = 5 mol% $\text{Cl}_2\text{Pd}(\text{PPh}_3)_2$, 10 mol% CuI, *i*-Pr₂NH, THF

Scheme 11.

2.5. Pd-Catalyzed α -alkylation of α -iodoenones (Protocol IIA)

Although α -alkylation of alkali metal enolates and related derivatives, such as enamines, proceeds satisfactorily in many cases, it still is desirable to develop a complementary α -haloenone-based α -alkylation methodology for the following reasons. Firstly, it would provide an efficient route to α -alkyl-substituted enones. Secondly, it might provide a satisfactory route to α -alkyl-substituted ketones even in cases where the conventional alkylation methodology is unsatisfactory. During the course of our study, an efficient synthesis of prostaglandin E₁ involving Pd-catalyzed α -alkylation of 2-iodo-4-(*t*-butyldimethylsiloxy)-2-cyclopentenone with *B*-(6-methoxycarbonyl)hexyl-9-BBN, where 9-BBN is 9-borabicyclo[3.3.1]nonane, was reported (Scheme 12) [44].

A systematic investigation of the Pd-catalyzed cross-coupling reaction of α -iodoenones with alkylzinc derivatives [45] indicates that both alkylzinc halides and dialkylzincs containing Me, primary alkyl, benzyl, homobenzyl, and homopropargyl groups react satisfactorily (Table 3). Benzylzinc derivatives prepared by treating benzylmagnesium bromide with ZnBr_2 are ineffective, but benzylzinc bromide prepared by treating PhCH_2Br with Zn is satisfactory. Secondary alkylzinc derivatives give cross coupling products in high yields, but it has thus far been difficult to avoid extensive

Table 3

Pd-catalyzed α -alkylation of α -iodoenones^a [45]

α -Iodoenone	Alkylzinc Derivative	Method of Generation ^b	Catalyst ^c	Product ^d	Yield (%) ^d
	Me_2Zn	A	I	I	85
	$(n\text{-Hex})_2\text{Zn}$	B	I	I	85 (81)
	$(i\text{-Bu})_2\text{Zn}$	B	I	I	85 (73)
	$(s\text{-Bu})_2\text{Zn}$	B	I	I	72 (61) ^e
	$(\text{PhCH}_2)_2\text{Zn}$	B	I	I	trace
	PhCH_2ZnBr	C	I	I	82 (74)
	$(n\text{-Bu})_2\text{Zn}$	B	I	I	76 (66)
	$(n\text{-Bu})_2\text{Zn}$	B	I	I	67 (59)
	$n\text{-HexZnBr}$	B	I	I	96
	PhCH_2ZnBr	C	I	I	94
	$\text{Me}_3\text{SiC}\equiv\text{C}(\text{CH}_2)_2\text{ZnI}$	C	II	I	80 (61)
	$\text{H}_2\text{C}=\text{CH}(\text{CH}_2)_2\text{ZnBr}$	D	II	I	36
	PhCH_2ZnBr	C	I	I	72
	$n\text{-BuZnBr}$	B	I	I	84
	PhCH_2ZnBr	C	I	I	71
	$\text{Ph}(\text{CH}_2)_2\text{ZnBr}$	D	I	I	83

^a Unless otherwise mentioned, the reactions were carried out at 23°C in DMF or DMF–THF using either 0.65 molar equivalents of a dialkylzinc bromide or iodide.

^b A = commercially available. B = $\text{RMgX} + 1/2 \text{ZnBr}_2$ (X = Br or I). C = $\text{RX} + \text{Zn}$. D = $\text{RX} + \text{Mg} + \text{ZnBr}_2$.

^c I = 5 mol% $\text{Cl}_2\text{Pd}(\text{PPh}_3)_2$. II = 5 mol% $\text{Cl}_2\text{Pd}(\text{TFP})_2$.

^d By NMR and/or GLC. The numbers in parentheses are isolated yields.

^e Completely isomerized to *n*-butyl. Additionally, 3-(*s*-butyl)cyclopentanone was also obtained in 12% yield.

secondary-to-primary isomerization observed with $\text{Cl}_2\text{Pd}(\text{PPh}_3)_2$ or conjugate addition with concomitant deiodination observed with $\text{Cl}_2\text{Pd}(\text{dppp})$ and $\text{Cl}_2\text{Pd}(\text{dppf})$ [46]. The results appear to indicate that substitution of α -iodoenones is significantly more demanding than that of other ordinary alkenyl halides. Somewhat surprisingly, all attempts to allylate α -iodocyclopentenone led to 1,2-addition of either allylzinc bromide or diallylzinc to the carbonyl group without the involvement of the C–I bond (Scheme 13) [45]. The

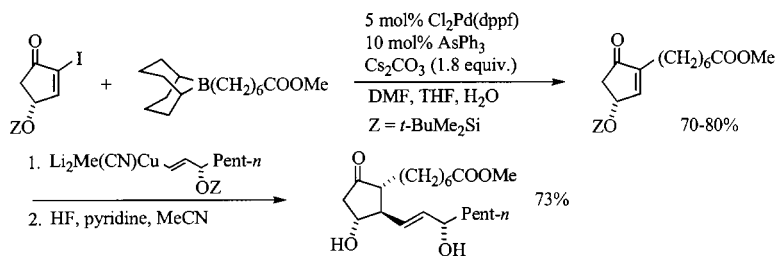

Scheme 12.

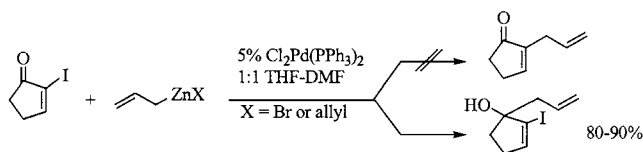

Scheme 13.

corresponding reaction of propargylzinc derivatives proceeds similarly via 1,2-addition.

2.6. Synthesis of α -iodoenones

One crucial requirement for the development of α -substitution procedures based on Protocol IIA is the availability of satisfactory procedures for the preparation of α -iodoenones. The reaction of cyclopentenone and cyclohexenone with IN_3 generated in situ from ICl and NaN_3 in MeCN was known to give the corresponding α -iodo derivatives in low yields [47]. However, adaptation of a procedure for α -bromination of enones [48] to α -iodination using I_2 and a tertiary amine, such as pyridine, has proved to be much more satisfactory (Table 4) [49]. Although persuasive comparative data are not presented, the use of I_2 , Me_3SiN_3 , and pyridine has been claimed to be superior to I_2 and pyridine alone in cases where enones are β -substituted (Table 4) [50,51].

One of the main incentives for developing the enone-based α -substitution methodology in our laboratories was the ready access to α -silyl- and α -stannylcyclopentenones via the Zr-promoted ene-yne cyclization-carbonylation [52]. Both monocyclic [53] and bicyclic [52] cyclopentenones are available by one-pot reactions. 2-Stannyl-2-cyclopentenones can be readily converted to the corresponding 2-iodo derivatives in excellent yields (80–95%) by iodination with I_2 or NIS [54]. However, the preparation of 2-stannyl-2-cyclopentenones by either the reaction of $n\text{-Bu}_2\text{ZrCp}_2$ with stannylated eny-

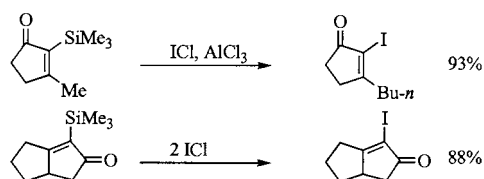

Scheme 14.

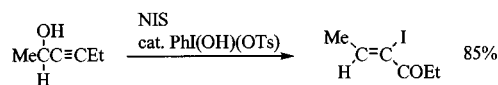

Scheme 15.

nes or that of Et_2ZrCp_2 with stannylated alkynes must avoid destannylation by the action of unreacted $n\text{-BuLi}$ or EtMgBr . We also hoped to avoid altogether organotin compounds for toxicity and other reasons. As 2-silyl-2-cyclopentenones can be prepared in a more reliable manner than the corresponding stannyl derivatives, we sought a method for their conversion to 2-iodo derivatives. Although those procedures that are satisfactory for converting parent enones to 2-iodoenones discussed above were very sluggish and uniformly unsatisfactory, the use of either two equiv. of ICl or one equiv. each of ICl and AlCl_3 proved to be very satisfactory (Scheme 14) [55].

Acyclic α -iodoenols and α -iodoenones have been prepared by treating propargyl alcohols with I_2 and pyridinium dichromate (PDC) [56] and NIS in the presence of a catalytic amount of PhI(OH)(OTs) (Scheme 15) [57].

2.7. Pd-Catalyzed α -substitution of α -metalloenones (Protocol IIB)

The ready accessibility of α -stannyl enones by Zr-promoted ene-yne cyclization-carbonylation prompted

Table 4
Conversion of enones to α -iodoenones with iodine and pyridine in carbon tetrachloride

Carbon number	α -Iodoenone	Yield (%)	Reference
5	2-Iodo-2-cyclopentenone	63	49
6	2-Iodo-3-methyl-2-cyclopentenone	56–63	49, 51
	2-Iodo-2-cyclohexenone	60–80	34, 49, 50
7	2-Iodo-4-acetoxy-2-cyclopentenone	77	49
	2-Iodo-3-methyl-2-cyclohexenone	70	49
8	2-Iodo-3-ethyl-2-cyclohexenone	70	50
9	2-Iodo-3-(<i>n</i> -butyl)-2-cyclopentenone	56	50
	2-Iodo-3-isopropyl-2-cyclohexenone	78	50
10	(<i>Z</i>)-3-Iodo-4-phenyl-3-buten-2-one	38	49
	2-Iodo-3-(3'-butenyl)-2-cyclohexenone	35	50
12	2-Iodo-3-pivaloyloxymethyl-2-cyclohexenone	80	35
13	2-Iodo-3-[(4'-trimethylsilyl-3'-butyn-1'-yl)]-2-cyclohexenone	85	50
18	2-Iodo-4-acetoxy-6-triisopropylsilyloxy-2-cycloheptenone	88	49

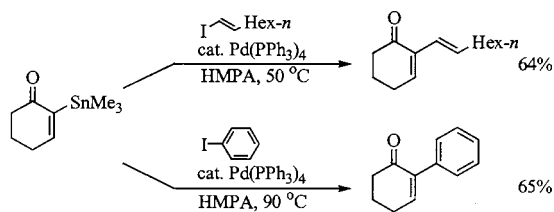

Scheme 16.

us to develop procedures for their Pd-catalyzed cross coupling with organic halides. We found that 2-trimethylstannyl-2-cyclopentenone prepared as a test substrate via lithiation-stannylation of cyclic acetal-protected 2-bromo-2-cyclopentenone reacted with (*E*)-1-octenyl iodide in the presence of 5 mol% of Pd(PPh₃)₄ to give the desired cross-coupling product in 80% yield [28]. Under comparable conditions, 2-trimethylstannyl-2-cyclohexenone reacted with (*E*)-1-octenyl iodide and phenyl iodide to give the corresponding cross-coupling products in about 65% yields (Scheme 16) [45]. Unfortunately, attempts to alkenylate 2-trimethylstannylbicyclo[3.3.0]oct-1-en-3-one by the same reaction were unsuccessful, the yield of the desired product being < 10%.

More recently, direct conversion of α -iodoenones into the corresponding α -zinco derivatives has been achieved using either an excess of Zn dust [58] or Zn–Ag couple (four equivalents) in the presence of TMEDA (one equivalent) [59]. The Zn reagents thus generated are less reactive than more usual alkenylzinc derivatives. Nonetheless, some satisfactory results have been obtained with aryl halides. On the other hand, variable results were obtained with alkenyl halides (Table 5) [58,59]. In summary, the α -zincoenone-based procedures appear to be somewhat more involved than the corresponding α -iodoenone-based procedures, and the cross-coupling yields tend to be lower. On the other hand, they do not require strongly basic organolithiums or Grignard reagents. Thus, they can tolerate a wider range of heteroatom functionalities.

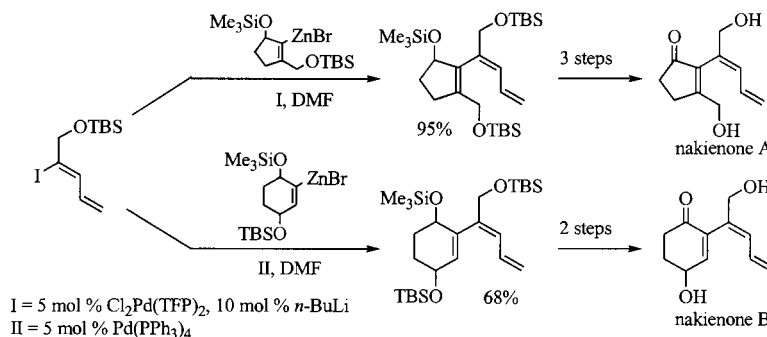

Scheme 17.

Table 5

Pd-catalyzed α -arylation and α -alkenylation of α -zincoenones^a

Enone	Aryl or Alkenyl Halide	Catalyst ^b	Product Yield (%)	Reference
		I	80	58
		I	71	58
		I	78–88	58
		I	70–81	58
		II	48	59
		III	32	59
		III	89	59
		III	70	59

^a 1.3 to 2 equiv. of organozinc reagents were used.^b I = 1 mol % Pd(dba)₂ and 4 mol % P()₃II = 5 mol % Pd(dba)₂ and 15 mol % AsPh₃. III = 5 mol % Pd(PPh₃)₄.

2.8. Pd-Catalyzed α -substitution of α -haloenols and α -metalloenols (Protocols IIIA and IIIB)

As mentioned in the previous section, the scope of Protocol IIB involving the use of α -stannyl and α -zincoenones appears to be generally more limited than that of Protocol IIA. And yet, it is very desirable or even mandatory in some cases to be able to use enone derivatives as nucleophiles rather than electrophiles. In such cases, Protocol I involving carbonyl-protected α -metalloenones may be considered. In our recent synthe-

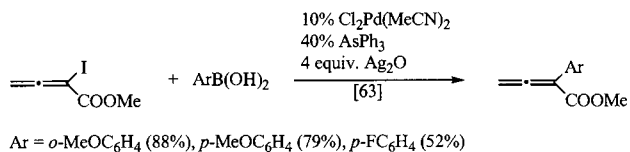

Scheme 20.

though the requirements for reduction, protection, deprotection, and reoxidation make Protocol III rather cumbersome, the generally clean and high-yielding Pd-catalyzed cross coupling seems to more than offset the disadvantages mentioned above in cases where Protocols IIA and IIB are not very satisfactory.

In a recent synthesis of bacbacyclin [54], a need for Protocol IIIA was encountered, when neither Protocol IIA nor Protocol IIB was shown to be satisfactory (Scheme 18) [54]. A clean and selective synthesis of the desired compound was achieved by resorting to Protocol IIIA, as shown in Scheme 19 [54].

It is clear that Protocol II is the most desirable of all discussed herein. However, the need for Protocol III as

discussed above indicates that there still is room for improvement of Protocol II. In the meantime, Protocol III may be employed as a reliable, if cumbersome, alternative for selective α -substitution of enones.

3. Other related Pd-catalyzed α -substitution methodologies

3.1. Pd-Catalyzed α -substitution of α -halo- and α -metallic esters and related amides

Various procedures for Pd-catalyzed α -substitution of α,β -unsaturated esters, amides, and related compounds have been developed since 1993 through application of Protocols IIA and IIB for α -substitution of enones. Although some procedures based on Protocol IIA involving Sn [62] and B [62,63] were found among early examples as summarized in Table 6 [62] and Scheme 20 [63], most represent applications of Protocol IIB using α -stannyl α,β -unsaturated esters, as summarized in Scheme 21 [64–68]. These procedures are gen-

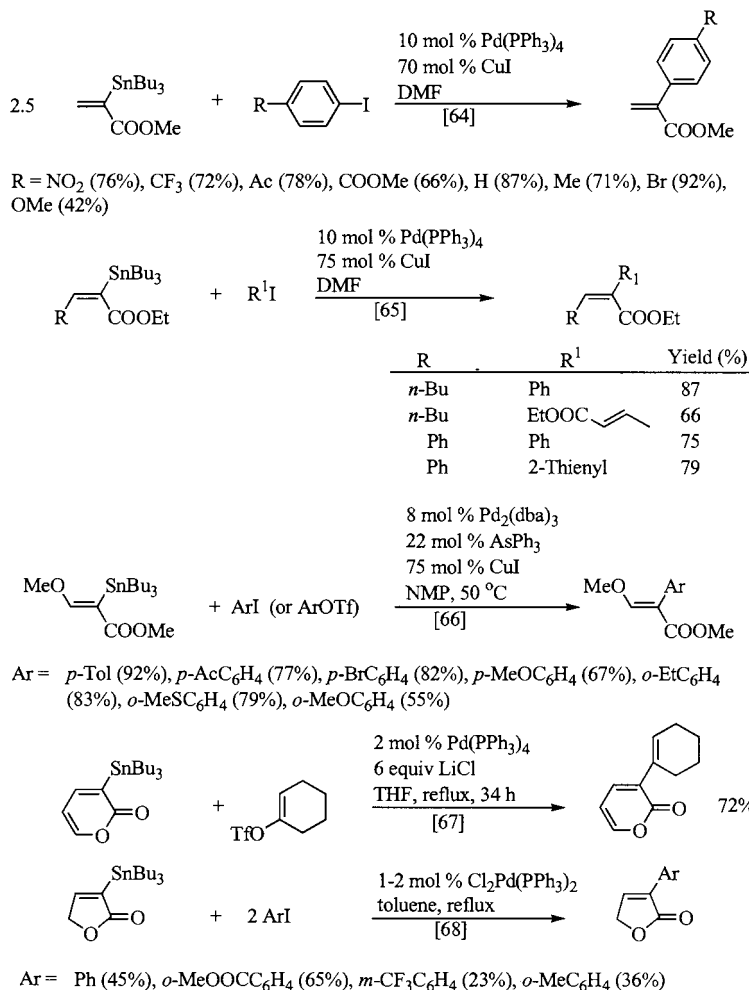

Scheme 21.

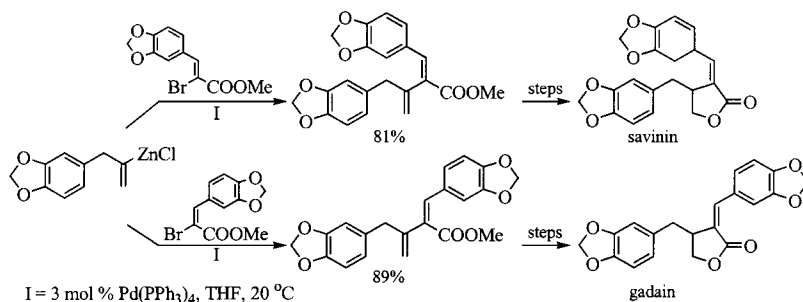

Scheme 22.

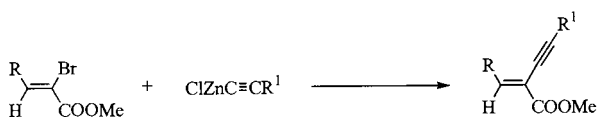

R	C≡CR ¹	Yield (%)
<i>n</i> -Bu	C=CHex- <i>n</i>	62
<i>i</i> -Bu	C≡CPh	71
3,5-Cl ₂ C ₆ H ₃	C≡CC ₆ H ₄ Me-4	84
3,5-Cl ₂ C ₆ H ₃	C≡CPr- <i>n</i>	74

Scheme 23.

erally associated with some undesirable features, such as the use of a significant excess of a stannane [64], or an organic halide [68], relatively large amounts (8–10

mol%) of Pd complexes [64–66], and the use of arsines. Clearly, further developments of the Pd-catalyzed α -substitution of α,β -unsaturated esters and amides are desirable. In this connection, more recent applications of Protocol IIA involving the reaction of α -bromoesters with organozincs in the presence of 5 mol% of Pd(PPh₃)₄ in THF are noteworthy (Scheme 22) [69,70]. Although reliable comparative data are not available, the generally favorable results of α -alkenylation (Scheme 22) [69] and α -alkynylation (Scheme 23) [70] suggest that organozincs may represent a generally satisfactory class of organometallic reagents in these cases as well. However, further critical comparisons among various available options are clearly desirable.

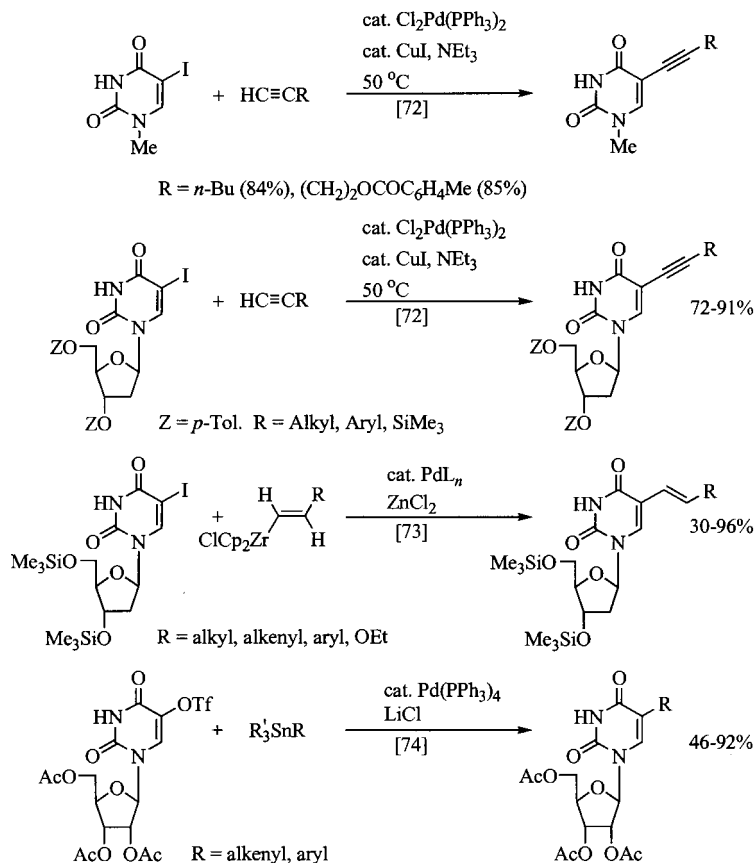

Scheme 24.

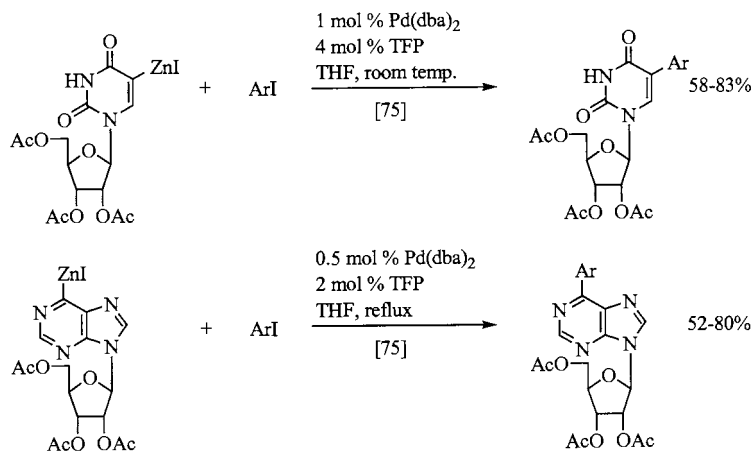

Scheme 25.

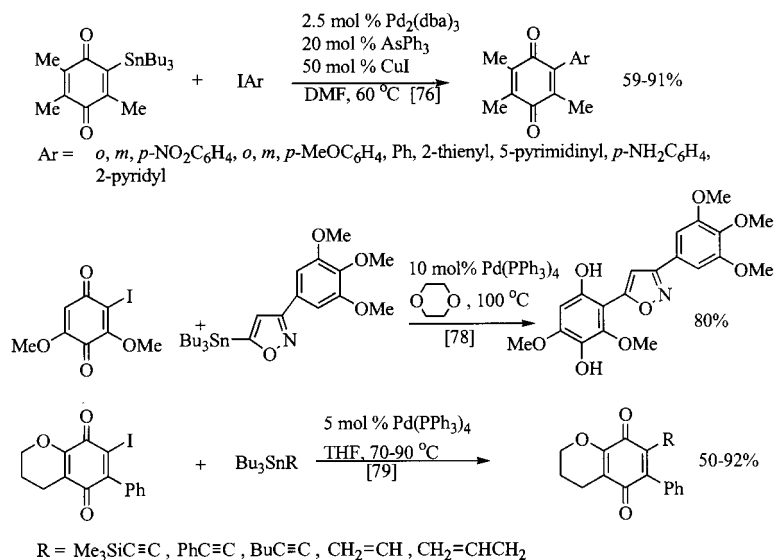

Scheme 26.

3.2. Pd-Catalyzed α -substitution of heteroaromatic α,β -unsaturated carbonyl derivatives, quinones, and related compounds

Application of the Pd-catalyzed cross coupling [71] to α -alkynylation [72], α -alkenylation [73], and α -arylation [73] of heteroaromatic α,β -unsaturated carbonyl derivatives, such as 5-iodouracil derivatives, has been known since the early 1980s (Scheme 24). Although these reactions are formally related to the Pd-catalyzed α -substitution discussed herein, the robust aromatic nature of the heteroaromatic substrates makes the requirements for their α -substitution less demanding. These reactions should therefore be viewed as a class of cross-coupling reactions involving aryl halides rather than α -halo- α,β -unsaturated carbonyl compounds. In most cases, heteroaryl iodides [72,73] and triflates [74] rather than heteroarylmethyls have been used. However, heteroarylzinc derivatives have also been employed (Scheme 25) [75]. As in the cases of α -substitution of enones, the required organozinc reagents are generated by treating

the corresponding iodides with Zn. This added requirement must be offset by some merits associated with the charge-affinity inverted protocol.

α -Substitution of haloquinones catalyzed by Pd complexes [76] may also be formally viewed as Pd-catalyzed α -substitution of enones. At the same time, however, these reactions also represent β -substitution of enones, which has been known to proceed much more readily than the corresponding α -substitution [28,77]. They must therefore be classified and viewed differently from those discussed in Section 2. Both iodoquinones [78] and metalloquinones [76,79] have been employed (Scheme 26).

4. Conclusions

In sharp contrast with the Pd-catalyzed cross coupling of β -haloenones, which is generally more facile than that of the corresponding alkenyl halides without the carbonyl functionality, the Pd-catalyzed cross coupling of

α -haloenones is intrinsically more difficult not only because the rate of the desired reaction is lower, but also because α -haloenones decompose more readily under the conditions used for cross coupling. Despite these difficulties, satisfactory protocols have been developed for cross coupling with organometals containing Zn, Sn, B and Cu to give α -organyleones in high yields. As in the other cases of Pd-catalyzed cross coupling, organozincs display generally the highest reactivity. Thus, their reactions are complete generally in a few to several hours at room temperature using Pd-PPh₃ complexes, whereas the other procedures tend to require more effective but potentially undesirable catalysts, such as those containing AsPh₃, and higher temperatures, typically 100 \pm 30°C. The use of polar aprotic solvents, such as DMF, appears to be generally more favorable than less polar solvents, such as THF, ether, benzene, and toluene. Essentially all types of organic groups, including aryl, alkenyl, alkynyl, methyl, primary alkyl, benzyl, homoallyl, homopropargyl, and homobenzyl, can be introduced in the α -position of enones. Secondary and tertiary alkyl groups tend to undergo isomerization and other side reactions, while allyl- and propargylzinc derivatives undergo selective 1,2-addition with α -iodoenones. Further developments are needed to accommodate these groups in the α -position of enones. In highly demanding and/or delicate situations, some indirect protocols, i.e. Protocols I and III, involving protection of carbonyl groups or their temporary reduction help overcome difficulties encountered in direct α -substitution (Protocol IIA and IIB). Collectively, these protocols represent novel and previously unavailable routes to α -substituted enones including various natural products that are attractive, efficient, and regioselective.

Equally important is that, in conjunction with conjugate reduction or conjugate addition, the enone-based Pd-catalyzed α -substitution methodology significantly supplements the conventional methodology for α -substitution of enolates. Particularly noteworthy features include (a) facile and reliable incorporation of unsaturated groups, such as aryl and alkenyl, in the α -position of carbonyl compounds and (b) strict control of regiochemistry. Due to space limitation, a vast topic of the Tsuji–Trost allylation of doubly stabilized enolates [80] and its extension accommodating more usual ketone and aldehyde enolates developed by us [81] and others [82] are not discussed here. Related arylation of ketones has received rekindled attention over the last few years, as briefly mentioned earlier [6,7], but the corresponding alkenylation, alkynylation, and so on still remain to be developed. Nor has the strict control of regiochemistry in non-obvious cases been demonstrated. Nonetheless, the operational simplicity of direct α -substitution of enolates is evident, and efforts toward the development of ultimately satisfactory α -substitution methodologies along this line are highly desirable.

Acknowledgements

The author is deeply indebted to a number of co-workers whose names are indicated in the pertinent references cited herein, especially Dr K. Akiyoshi for his pioneering work on Protocol I, Drs Z. Owczarczyk and D.R. Swanson for the first development of Protocol IIA, and Dr M. Pour for developing Protocol III. Dr A. Alimardanov, B. Liao, S.Y. Liou, and Z. Tan are currently engaged in research in this area. Our investigations have been mainly supported by the National Institutes of Health (GM36792), and palladium compounds have been kindly supplied by Johnson–Matthey Inc.

References

- [1] For reviews, see (a) H.O. House, *Modern Synthetic Reactions*, 2nd Ed., W.A. Benjamin, Menlo Park, CA, 1972, pp. 492–595. (b) R.C. Larock, *Comprehensive Organic Transformations*, VCH, New York, 1989, pp. 738–776.
- [2] (a) R.A. Rossi, J.F. Bunnett, *J. Am. Chem. Soc.* 94 (1972) 683. (b) R.A. Rossi, J.F. Bunnett, *J. Org. Chem.* 38 (1973) 3020. (c) J.F. Bunnett, B.F. Gloor, *J. Org. Chem.* 38 (1973) 4156. (d) J.F. Bunnett, B.F. Gloor, *J. Org. Chem.* 39 (1974) 382.
- [3] M.F. Semmelhack, B.P. Chong, R.D. Stauffer, T.D. Rogerson, A. Chong, L.D. Jones, *J. Am. Chem. Soc.* 97 (1975) 2507.
- [4] I. Kuwajima, H. Urabe, *J. Am. Chem. Soc.* 104 (1982) 6831.
- [5] (a) M. Kosugi, M. Suzuki, I. Hagiwara, K. Goto, K. Saitoh, T. Migita, *Chem. Lett.* (1982) 939. (b) M. Kosugi, I. Hagiwara, T. Sumiya, T. Migita, *Bull. Chem. Soc. Jpn.* 57 (1984) 242.
- [6] M. Palucki, S.L. Buchwald, *J. Am. Chem. Soc.* 119 (1997) 11108.
- [7] B.C. Hamam, J.F. Hartwig, *J. Am. Chem. Soc.* 119 (1997) 12382.
- [8] M. Kosugi, I. Hagiwara, T. Migita, *Chem. Lett.* (1983) 839.
- [9] A.A. Millard, M.W. Rathke, *J. Am. Chem. Soc.* 99 (1977) 4833.
- [10] (a) J.F. Fauvarque, A. Jutand, *J. Organomet. Chem.* 132 (1977) C17. (b) J.F. Fauvarque, A. Jutand, *J. Organomet. Chem.* 177 (1979) 273. (c) J.F. Fauvarque, A. Jutand, *J. Organomet. Chem.* 209 (1981) 109.
- [11] M. Uno, K. Seto, S. Takahashi, *J. Chem. Soc. Chem. Commun.* (1984) 932.
- [12] M. Ciufolini, M.E. Browne, *Tetrahedron Lett.* 28 (1987) 171.
- [13] (a) J.T. Pinhey, B.A. Rowe, *Aust. J. Chem.* 33 (1980) 113. (b) M.G. Moloney, J.T. Pinhey, *J. Chem. Soc. Chem. Commun.* (1984) 965. (c) R.P. Kozyrod, J.T. Pinhey, *Aust. J. Chem.* 38 (1985) 1155. (d) M.G. Moloney, J.T. Pinhey, *J. Chem. Soc. Perkin Trans I* (1988) 2847.
- [14] (a) M.G. Moloney, J.T. Pinhey, R.G. Roche, *Tetrahedron Lett.* 27 (1986) 5025. (b) S. Hashimoto, Y. Miyazaki, T. Shinoa, S. Ikegami, *J. Chem. Soc. Chem. Commun.* (1990) 1100.
- [15] (a) A.S. Kende, P. Fludzinski, *Tetrahedron Lett.* 23 (1982) 2373. (b) A.S. Kende, P. Fludzinski, J.H. Hill, W. Swenson, J. Clardy, *J. Am. Chem. Soc.* 106 (1984) 3551.
- [16] (a) H.C. Brown, M.M. Rogić, R.W. Rathke, *J. Am. Chem. Soc.* 90 (1968) 6218. (b) H.C. Brown, H. Nambu, M.M. Rogić, *J. Am. Chem. Soc.* 91 (1969) 6852. (c) H.C. Brown, M.M. Rogić, *J. Am. Chem. Soc.* 91 (1969) 4304. (d) H.C. Brown, N.G. Bhat, J.B. Campbell, Jr., *J. Org. Chem.* 51 (1986) 3398.
- [17] (a) D.H.R. Barton, D.J. Lester, W.W. Motherwell, M.T. Barros Papoula, *J. Chem. Soc. Chem. Commun.* (1980) 246.
- [18] (a) C.E. Sacks, P.L. Fuchs, *J. Am. Chem. Soc.* 97 (1975) 7372. (b) M.W. Rathke, D. Vogiazoglou, *J. Org. Chem.* 52 (1987) 3697.
- [19] (a) T.C.T. Chang, M. Rosenblum, S.B. Samuels, *J. Am. Chem. Soc.* 102 (1980) 5931. (b) T.C.T. Chang, M. Rosenblum, *J. Org.*

- Chem. 46 (1981) 4105. (c) M. Marsi, M. Rosenblum, *J. Am. Chem. Soc.* 106 (1984) 7264.
- [20] (a) C.J. Kowalski, J.S. Dung, *J. Am. Chem. Soc.* 102 (1980) 7950. (b) D.L.J. Clive, C.G. Russell, *J. Chem. Soc. Chem. Commun.* (1981) 434. (c) D.L.J. Clive, C.G. Russell, S. ChanderSuri, *J. Org. Chem.* 47 (1982) 1632.
- [21] P.F. Hudrlik, A.K. Kulkarni, *J. Am. Chem. Soc.* 103 (1981) 6251.
- [22] P.A. Wender, D.A. Holt, S.M. Sieburth, *J. Am. Chem. Soc.* 105 (1983) 3348.
- [23] R.C. Larock, *Comprehensive Organic Transformations*, VCH, New York, 1989, p. 776–784.
- [24] (a) P.A. Wender, J.M. Erhardt, L.J. Letendre, *J. Am. Chem. Soc.* 103 (1981) 2114. (b) J.P. Marino, J.C. Jaén, *J. Am. Chem. Soc.* 104 (1982) 3165.
- [25] E. Negishi, R.A. John, *J. Org. Chem.* 48 (1983) 4098.
- [26] (a) E. Negishi, M.J. Idacavage, F. DiPasquale, A. Silveira, Jr., *Tetrahedron Lett.* (1979) 845. (b) M.J. Idacavage, E. Negishi, C.A. Brown, *J. Organomet. Chem.* 185 (1980) C55. (c) E. Negishi, H. Matsushita, S. Chatterjee, R.A. John, *J. Org. Chem.* 47 (1982) 3188. (d) E. Negishi, F.T. Luo, A.J. Pecora, A. Silveira, Jr., *J. Org. Chem.* 48 (1983) 2427. (e) E. Negishi, R.A. John, *J. Org. Chem.* 48 (1983) 4098. (f) F.T. Luo, E. Negishi, *Tetrahedron Lett.* 26 (1985) 2177. (g) F.T. Luo, E. Negishi, *J. Org. Chem.* 50 (1985) 4762.
- [27] E. Negishi, K. Akiyoshi, *Chem. Lett.* (1987) 1008.
- [28] E. Negishi, Z. Owczarczyk, D.R. Swanson, *Tetrahedron Lett.* 32 (1991) 4453.
- [29] M.A. Guaciaro, P.M. Wovkulich, A.B. Smith, III, *Tetrahedron Lett.* (1978) 4661.
- [30] E. Negishi, T. Takahashi, S. Baba, D.E. Van Horn, N. Okukado, F.T. Luo, *J. Am. Chem. Soc.* 109 (1987) 2393 and pertinent references therein.
- [31] M.F. Semmelhack, R. Stauffer, A. Yamashita, *J. Org. Chem.* 42 (1977) 3180.
- [32] (a) V. Farina, S.R. Baker, C. Sapino, Jr., *Tetrahedron Lett.* 29 (1988) 6043. (b) V. Farina, S.R. Baker, D.A. Benigni, S.I. Hauck, C. Sapino, Jr., *J. Org. Chem.* 55 (1990) 5833. (c) V. Farina, B. Krishnan, *J. Am. Chem. Soc.* 113 (1991) 9585.
- [33] C.R. Johnson, J.P. Adams, M.P. Braun, C.B.W. Senanayake, *Tetrahedron Lett.* 33 (1992) 919.
- [34] F.S. Ruel, M.P. Braun, C.R. Johnson, *Org. Synth.* 75 (1998) 69.
- [35] F. Bosse, A.R. Tunoori, M.E. Maier, *Tetrahedron* 53 (1997) 9159.
- [36] F. Bellina, A. Carpita, D. Ciucci, M. DeSantis, R. Rossi, *Tetrahedron* 49 (1993) 4677.
- [37] C.R. Johnson, J.P. Adams, M.A. Collins, *J. Chem. Soc. Perkin Trans. 1* (1993) 1.
- [38] N.S. Sirisoma, C.R. Johnson, *Tetrahedron Lett.* 39 (1998) 2059.
- [39] P. Margaretha, S. Reichow, W.C. Agosta, *J. Org. Chem.* 59 (1994) 5393.
- [40] Z. Tan, E. Negishi, 215th ACS National Meeting, Dallas, TX, March 29–April 2, 1998, ORGN0083.
- [41] T. Kamikubo, K. Ogasawara, *Chem. Commun.* (1996) 1679; *Heterocycles* 47 (1998) 69.
- [42] D.L. Comins, S.P. Joseph, X. Chen, *Tetrahedron Lett.* 36 (1995) 9141.
- [43] M.W. Miller, C.R. Johnson, *J. Org. Chem.* 62 (1997) 1582.
- [44] C.R. Johnson, M.P. Braun, *J. Am. Chem. Soc.* 115 (1993) 11014.
- [45] E. Negishi et al., manuscript in preparation.
- [46] T. Hayashi, M. Konishi, M. Kumada, *Tetrahedron Lett.* 21 (1979) 1871.
- [47] J.M. McIntosh, *Can. J. Chem.* 49 (1971) 3045.
- [48] A.B. Smith, III, S.J. Branca, M.A. Guaciaro, P.M. Wovkulich, A. Korn, *Org. Synth. Coll. Vol. VII* (1990) 271.
- [49] C.R. Johnson, J.P. Adams, M.P. Braun, C.B.W. Senanayake, P.M. Wovkulich, M.R. Uskokovic, *Tetrahedron Lett.* 33 (1992) 917.
- [50] C.K. Sha, S.J. Huang, *Tetrahedron Lett.* 36 (1995) 6927.
- [51] W.R. Roush, D.A. Barda, *Tetrahedron Lett.* 38 (1997) 8785.
- [52] (a) E. Negishi, S.J. Holmes, J.M. Tour, J.A. Miller, *J. Am. Chem. Soc.* 107 (1985) 2568. (b) E. Negishi, S.J. Holmes, J.M. Tour, J.A. Miller, F.E. Cederbaum, D.R. Swanson, T. Takahashi, *J. Am. Chem. Soc.* 111 (1989) 3336.
- [53] (a) T. Takahashi, M. Kageyama, V. Denisov, R. Hara, E. Negishi, *Tetrahedron Lett.* 34 (1993) 687. (b) T. Takahashi, Z. Xi, Y. Nishiyama, S. Huo, K. Kasai, K. Aoyagi, V. Denisov, *Tetrahedron* 53 (1997) 9123.
- [54] E. Negishi, M. Pour, F.E. Cederbaum, M. Kotora, *Tetrahedron* 54 (1998) 7057.
- [55] A. Alimardanov, E. Negishi, manuscript in preparation.
- [56] (a) R. Antonioletti, M. D'Auria, G. Piancatelli, A. Scettri, *Tetrahedron Lett.* (1981) 1041. (b) P. Bovonsombat, G.J. Angara, E. McNelis, *Tetrahedron Lett.* 35 (1994) 6787.
- [57] G.J. Angara, E. McNelis, *Tetrahedron Lett.* 32 (1991) 2099.
- [58] A.S.B. Prasad, P. Knochel, *Tetrahedron* 53 (1997) 16711.
- [59] R. Rossi, F. Bellina, D. Ciucci, *J. Organomet. Chem.* 542 (1997) 113.
- [60] M. Pour, E. Negishi, *Tetrahedron Lett.* 38 (1997) 525.
- [61] M. Pour, E. Negishi, *Tetrahedron Lett.* 37 (1996) 4679.
- [62] B.J. Newhouse, A.I. Meyers, N.S. Sirisoma, M.P. Braun, C.R. Johnson, *Synlett* (1993) 573.
- [63] T. Gillmann, T. Weeber, *Synlett* (1994) 649.
- [64] J.I. Levin, *Tetrahedron Lett.* 34 (1993) 6211.
- [65] F. Bellina, A. Carpita, M. DeSantis, R. Rossi, *Tetrahedron* 50 (1994) 12029.
- [66] D.M. Hodgson, J. Witherington, B.A. Moloney, I.C. Richards, J.L. Brayer, *Synlett* (1995) 32.
- [67] Z. Liu, J. Meinwald, *J. Org. Chem.* 61 (1996) 6693.
- [68] G.J. Hollingworth, G. Perkins, J. Sweeney, *J. Chem. Soc. Perkin Trans. 1* (1996) 1913.
- [69] R. Rossi, F. Bellina, C. Bechini, L. Mannina, *Synlett* (1997) 1061.
- [70] R. Rossi, F. Bellina, C. Bechini, L. Mannina, P. Vergamini, *Tetrahedron* 54 (1998) 135.
- [71] F. Diederich, P.J. Stang, Eds., *Metal-Catalyzed Cross-Coupling Reactions*, Wiley–VCH, Weinheim, p. 517, 1998.
- [72] M.J. Robins, P.J. Barr, *Tetrahedron Lett.* 22 (1981) 421. For earlier Heck-type α -alkenylation, see references cited therein.
- [73] P. Vincent, J.P. Beaucourt, L. Picket, *Tetrahedron Lett.* 23 (1982) 63.
- [74] G.T. Crisp, B.L. Flynn, *Tetrahedron Lett.* 31 (1990) 1347.
- [75] (a) T.M. Stevenson, A.S.B. Prasad, J.R. Citineni, P. Knochel, *Tetrahedron Lett.* 37 (1996) 8375. (b) A.S.B. Prasad, T.M. Stevenson, J.R. Citineni, V. Nyzam, P. Knochel, *Tetrahedron Lett.* 53 (1997) 7237.
- [76] (a) L.S. Liebeskind, S.W. Riesinger, *J. Org. Chem.* 58 (1993) 408. (b) G.D. Allred, L.S. Liebeskind, *J. Am. Chem. Soc.* 118 (1996) 2748.
- [77] (a) S. Baba, E. Negishi, *J. Am. Chem. Soc.* 98 (1976) 6729. (b) A.O. King, N. Okukado, E. Negishi, *J. Chem. Soc. Chem. Commun.* (1977) 683. (c) N. Okukado, D.E. Van Horn, W.L. Klima, E. Negishi, *Tetrahedron Lett.* (1978) 1027. (d) E. Negishi, N. Okukado, A.O. King, D.E. Van Horn, B.I. Spiegel, *J. Am. Chem. Soc.* 100 (1978) 2254. (e) M. Kobayashi, E. Negishi, *J. Org. Chem.* 45 (1980) 5223.
- [78] K.V. Gothlf, K.B.G. Torrsell, *Acta Chem. Scand.* 48 (1994) 61.
- [79] K.S. Chan, C.C. Mak, *Tetrahedron* 50 (1994) 2003.
- [80] (a) B.M. Trost, *Acc. Chem. Res.* 13 (1980) 385. (b) J. Tsuji, I. Minami, *Acc. Chem. Res.* 20 (1987) 140.
- [81] (a) E. Negishi, H. Matsushita, S. Chatterjee, R.A. John, *J. Org. Chem.* 47 (1982) 3188. (b) H. Matsushita, E. Negishi, *J. Chem. Soc. Chem. Commun.* (1982) 160. (c) E. Negishi, F.T. Luo, A.J. Pecora, A. Silveira, Jr., *J. Org. Chem.* 48 (1983) 2427. (d) E. Negishi, R.A. John, *J. Org. Chem.* 48 (1983) 4098. (e) F.T. Luo, E. Negishi, *Tetrahedron Lett.* 26 (1985) 2177. (f) F.T. Luo, E. Negishi, *J. Org. Chem.* 50 (1985) 4762.
- [82] (a) T. Hirao, N. Yamada, Y. Ohshiro, T. Agawa, *J. Organomet. Chem.* 236 (1982) 409. (b) J. Tsuji, I. Minami, I. Shimizu, *Tetrahedron Lett.* 24 (1983) 1793, 4713. (c) J. Tsuji, I. Minami, I. Shimizu, *Chem. Lett.* (1983) 1325.