



ELSEVIER

Binuclear hydrido platinum(II) complexes: syntheses of $[\{\text{Pt}(\text{P}-\text{P})\}_2(\mu\text{-CHCH}_2\text{R})(\mu\text{-H})][\text{BF}_4]$ ($\text{R} = \text{C}_6\text{H}_5$, H) and easy cleavage of a P–C bond in a chelating 1,4-bis(diphenyl)phosphinobutane (P–P)

Anna Laura Bandini ^a, Guido Banditelli ^{a,*}, Giovanni Minghetti ^b

^a Dipartimento di Chimica Inorganica, Metallorganica e Analitica, Università di Milano, Centro CNR, via G. Venezian, I-20133 Milan, Italy

^b Dipartimento di Chimica, Università di Sassari, via Vienna 2, Sassari, Italy

Received 8 June 1999; accepted 28 September 1999

Abstract

Reactions of the binuclear platinum(II) trihydrido complex, $[\text{Pt}_2\{(\text{Ph}_2\text{P})_2(\text{CH}_2)_4\}_2(\text{H})_3][\text{BF}_4]$, with styrene or ethylene, at room temperature and low pressure, give μ -alkylidene, μ -hydrido cationic species $[\text{Pt}_2\{(\text{Ph}_2\text{P})_2(\text{CH}_2)_4\}_2(\mu\text{-CHCH}_2\text{R})(\mu\text{-H})][\text{BF}_4]$ ($\text{R} = \text{C}_6\text{H}_5$, **1**; H , **2**) together with an unexpected phosphido-bridged binuclear platinum(II) compound (**3**), originating from cleavage of a P–C bond in the coordinated diphosphine. Complexes **1–3** are discussed on the basis of FAB MS, IR and multinuclear NMR spectra in solution. © 2000 Elsevier Science S.A. All rights reserved.

Keywords: Binuclear complexes; Platinum; Hydride; Alkylidene; Phosphide; P–C cleavage

1. Introduction

Transition metal hydrides are still an interesting topic in organometallic chemistry, covering an area of interests that ranges from theoretical to applied aspects.

Binuclear hydrido platinum complexes stabilized by chelating diphosphino ligands have been known since 1977 [1], and many papers have been published which deal with their synthesis and spectroscopic and structural characterization [2]. However their reactivity seems not to be much explored.

Previously it was established that the platinum(II) trihydrido cations, $[\text{Pt}_2(\text{P}-\text{P})_2(\text{H})_3]^+$, react with two electron donors, such as CO or RNC, to give binuclear platinum(I) μ -hydrido species, $[\text{Pt}_2(\text{P}-\text{P})_2(\mu\text{-H})(\mu\text{-L})]^+$ ($\text{L} = \text{CO}$, RNC), by a formal loss of H_2 [3]. Afterwards, the first binuclear μ -alkylidene, μ -hydrido platinum derivative, $[\text{Pt}_2(\text{dppe})_2(\mu\text{-H})(\mu\text{-CHCH}_2\text{C}_6\text{H}_5)]^+$, was isolated by reaction of $[\text{Pt}_2(\text{dppe})_2(\text{H})_3][\text{BF}_4]$ with styrene, according to the reaction:

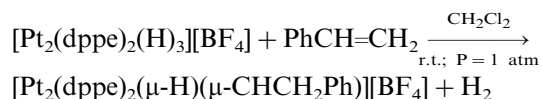

The latter species, fully characterized in solution, as well as in the solid state [4], has been for a long time the unique example of this kind of platinum complex. Very recently, the homologous cation $[\text{Pt}_2(\text{dppf})_2(\mu\text{-H})(\mu\text{-CHCH}_2\text{Ar})]^+$ ($\text{dppf} = (\text{Ph}_2\text{P})_2\{(\text{C}_5\text{H}_4)_2\text{Fe}\}$; $\text{Ar} = p\text{-MeOC}_6\text{H}_4$) has been obtained through a different reaction pathway [5].

Following our interest towards binuclear platinum(II) trihydrides with chelating diphosphinoalkanes, here we report the results of the reaction of $[\text{Pt}_2(\text{dppb})_2(\text{H})_3]^+$ ($\text{dppb} = \text{Ph}_2\text{P}(\text{CH}_2)_4\text{PPh}_2$) with styrene or ethylene: the μ -hydrido, μ -alkylidene derivatives, $[\text{Pt}_2(\text{dppb})_2(\mu\text{-H})(\mu\text{-CHCH}_2\text{R})]^+$ ($\text{R} = \text{C}_6\text{H}_5$, **1**; $\text{R} = \text{H}$, **2**), are obtained together with a rather uncommon binuclear platinum(II) μ -phosphido, μ -hydrido cation (**3**).

The few examples of μ -phosphido, μ -hydrido cations known up to now were obtained from tertiary phosphines, monodentate [6] or P,C-coordinated [7], and from a secondary alkylphosphine [8] or, under drastic condi-

* Corresponding author. Fax: +39-02-2362748.

E-mail address: banditel@inbox.csmto.mi.cnr.it (G. Banditelli)

tions, by decomposition of platinum(II) diphenylphosphinous acid complexes [9].

Transition-metal-mediated P–C cleavage has been largely explored for many years, involving, inter alia, catalyst deactivation and organic fragments transfer reactions [10]. However, in platinum complexes with chelating diphosphines, P–C bond cleavage under mild conditions is unprecedented. The cleavage of the P–methylene bond reported in the case of dppmPtX_2 ($\text{dppm} = \text{Ph}_2\text{P}(\text{CH}_2)\text{PPh}_2$; $\text{X} = \text{Cl}$, $\{1/2\text{S}_2\text{CNET}_2, 1/2\text{acac}\}$) complexes [11] occurs only with an alkali source.

Finally it is worth noting that, apart from the cations $[\text{Pt}(\text{dpppe})(\mu\text{-PRR}')_2]^+$ ($\text{R} = \text{R}' = \text{Ph}$ [12]; $\text{R} = \text{H}$, $\text{R}' = 2,4,6\text{-Me}_3\text{C}_6\text{H}_2$ [13]), binuclear μ -phosphido platinum complexes with chelating diphosphines are poorly investigated, despite the results obtained with tertiary–secondary diphosphines by Meek and coworkers [14] in the past decade.

2. Results and discussion

The reactions of $[\text{Pt}_2(\text{dppb})_2(\text{H})_3][\text{BF}_4]$ with styrene or ethylene were carried out under very mild conditions, i.e. stirring a CH_2Cl_2 solution of the platinum complex with a large excess of styrene at room temperature or in a pressure bottle with ethylene charged at ca. 2.5 atm. After a week, a white solid, stable in solution and in solid state, was isolated.

2.1. Characterization of compounds 1 and 2

The $^1\text{H-NMR}$ spectra of the crude products (Fig. 1) show that, in both the reactions, two different hydrido derivatives (**1** + **3** and **2** + **3**, respectively) are formed. According to the intensity ratio of the satellites of the hydrido resonances (ca. 1:8:18:8:1), complexes **1**–**3** should be binuclear species.

The signals at lower field (quintets of triplets of triplets) in both the mixtures, **1** + **3** or **2** + **3**, consistent with molecules having two equivalent platinum atoms and four terminal P atoms, two by two equivalent, can be attributed to the μ -alkylidene μ -hydrido cations, **1** and **2**, by comparison with similar species, in particular with the homologous cations **4** [4] and **5** [5], both characterized by X-ray crystal structures.

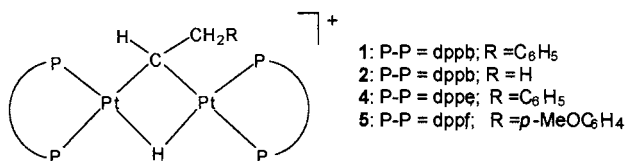

The structures of complexes **1** and **2** were also confirmed by comparison of multinuclear NMR data (Table 1).

The FAB MS spectra of **1** as well as those of the crude mixtures (**1** + **3** and **2** + **3**) show the presence of the molecular ions of the μ -alkylidene cations (**1**: $[\text{M}]^+ = 1347\text{ m/z}$; **2**: $[\text{M}]^+ = 1271\text{ m/z}$): both these molecular peaks lose a fragment corresponding to the appropriate CHCH_2R moiety ($\text{R} = \text{C}_6\text{H}_5$, **1**; $\text{R} = \text{H}$, **2**) giving the same cluster at 1243 m/z . In mixtures of **1** + **3**, enriched in compound **3**, the relative abundance of the ion at 1243 m/z increases, indicating that the same cluster originates also from compound **3**, not only by fragmentation of **1** or **2**. Therefore it seems that the 1243 m/z ions can be considered representative of the molecular ion of compound **3**.

2.2. Compound 3

Flash chromatography on silica gel of a mixture of **1** + **3** allowed isolation of compound **1** as an analytically pure sample. Attempts to achieve separation of compounds **2** and **3** were unsuccessful.

After separation of compound **1**, the mixture of **1** + **3** is largely enriched in the component **3**, (ca. 60%), thus allowing significant spectroscopic investigations.

A medium vibration at 1570 cm^{-1} in the IR spectra of the crude mixtures, either **1** + **3** or **2** + **3**, not observed in the spectrum of **1** and possibly due to the bridging hydride, seems to be diagnostic for the presence of derivative **3**.

In the compound **3** the platinum atoms are not equivalent, as shown by the complex ^1H resonance at higher field ($-7.0\text{ }\delta$) (Fig. 1). Apart from the hydrido resonance, the $^1\text{H-NMR}$ spectra of the reaction mixtures do not provide significant data on compound **3**.

In the $^{31}\text{P}\{^1\text{H}\}$ -NMR spectra of the mixtures (**1** + **3**; **2** + **3**) four resonances can be assigned to compound **3**. The resonance at very low field ($118.5\text{ }\delta$) (Fig. 2) can be regarded as diagnostic for a triangular phosphido-bridged moiety [10a,b], whereas the other ones indicate three inequivalent phosphorus atoms. The former resonance consists of a central doublet of doublets of doublets (eight lines) originated from coupling to three different P nuclei in the isotopomer with no ^{195}Pt nuclei (relative abundance 43.8%), flanked by two sets of satellites (1:1 ratio; 16×2 lines) due to two different isotopomers with one ^{195}Pt nucleus (22.4% each one), confirming the non-equivalence of the Pt centers. Finally, even the subspectrum arising from the isotopomer with two ^{195}Pt nuclei (11.4%) is almost observed completely. The ratios among the central resonance and the observed subspectra approximate well the values calculated for binuclear derivatives.

The $^2J_{\text{PP}}$ values (Table 2), obtained from the spectrum of the main isotopomer, clearly indicate that two P atoms (P_2 and P_3) are *trans* to the bridging phosphido ligand (P_1) and one (P_4) occupies a *cis* position, allowing the assignment of the three resonances at 17.1, 11.6

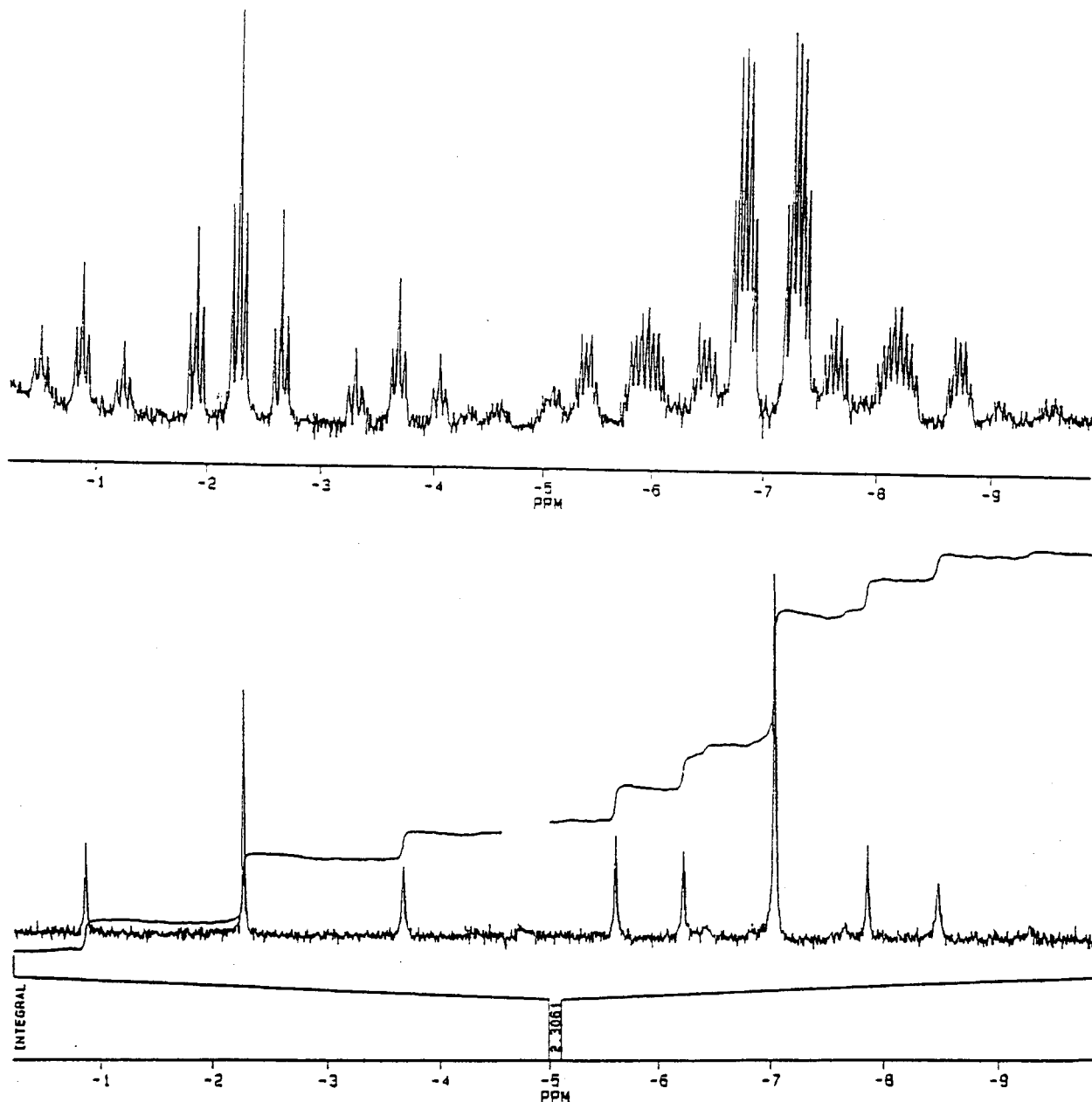

Fig. 1. ^1H -NMR spectra of a mixture of **2** and **3** in the hydrido region. Top: undecoupled spectrum; bottom: fully ^{31}P decoupled.

and 0.94δ to P_3 , P_2 , and P_4 , respectively; in addition, P_2 and P_4 show a small coupling ($^2J_{\text{P}_2\text{P}_4} = 17 \text{ Hz}$) attributable to a mutually *cis* arrangement. The simulated spectrum (Fig. 2b) fits the experimental observations, assuming $^1J_{\text{Pt}_1\text{Pt}_2} = 360 \text{ Hz}$, as obtained from the $^{195}\text{Pt}\{^1\text{H}, ^{31}\text{P}\}$ spectrum.

In agreement, in the ^{195}Pt -NMR spectra (Fig. 3) the resonance at higher field can be assigned to a platinum atom bonded to three different P atoms (P_1 , P_2 , and P_4) and the other one to a platinum coordinated to two P donors (P_1 , and P_3). As expected owing to the presence of the hydrido ligand, both the resonances give a doublet in the $^{195}\text{Pt}\{^{31}\text{P}\}$ -NMR spectra. The spectra fit

those reported for cation **6** (see later) [6]: the $\delta^{195}\text{Pt}$ values of **3** and **6** are shielded more than 1300 ppm with respect to those of μ -phosphido platinum(II) complexes with an open core [14c].

Thus the following skeleton should be considered for compound **3**.

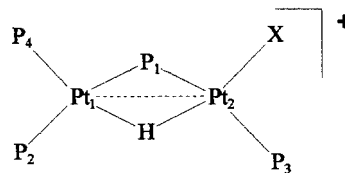

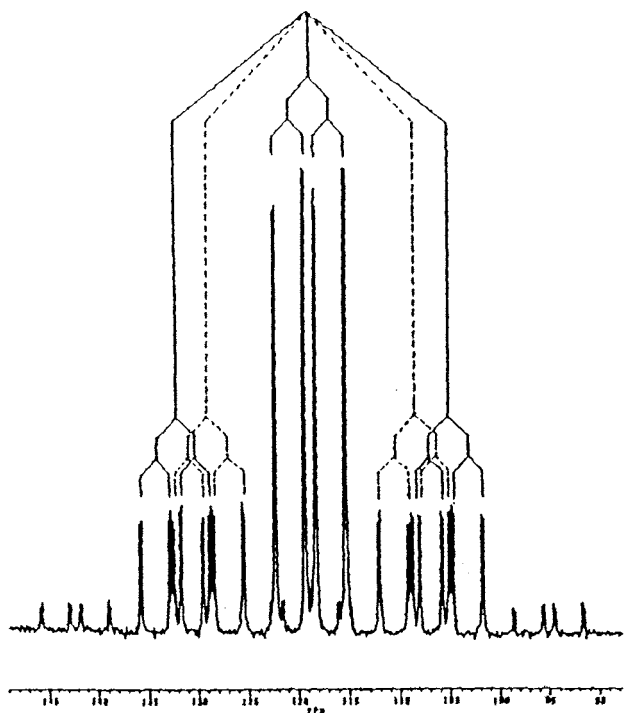

Fig. 2. $^{31}\text{P}\{^1\text{H}\}$ -NMR spectrum: resonance of the bridging phosphido at low field (118 δ).

On the whole, the ^1H - and $^{31}\text{P}\{^1\text{H}\}$ -, and ^{195}Pt -NMR spectra (Table 2) are very similar to those reported for the fully characterized platinum(II) μ -phosphido, μ -hydrido cations $[(\text{R}_2\text{R}'\text{P})_2\text{Pt}(\mu\text{-H})(\mu\text{-R}_2\text{P})\text{Pt}(\text{R}_2\text{R}'\text{P})(\text{X})]^+$ (**6**: $\text{R} = \text{R}' = \text{X} = \text{Ph}$ [6]; **6a** as BF_4^- [6a], and **6b** as $[\text{HC}(\text{SO}_2\text{CF}_3)_2]^-$ [6b]; **7**: $\text{R} = \text{R}' = \text{X} = 4\text{-F-Ph}$ [6b]; **8**: $\text{R} = \text{Bu}'$, $\text{R}' = \text{X} = \text{H}$ [8]), which have been shown to have the same skeleton: the coordination geometry at

each platinum atom closely approximates square-planar in an essentially planar core ($\text{Pt}_1\text{P}_1\text{Pt}_2$), as inferred from X-ray crystal structure determinations [6].

The set of hydrido resonances (Table 2) appears substantially defined by the above considered skeleton, not showing any significant difference in dependence of the various phosphino or phosphido ligands.

In contrast, some observations could be made on the $^{31}\text{P}\{^1\text{H}\}$ -NMR data: in comparison with cations **3–7**, the remarkable downfield shift ($\Delta\delta \approx 80$ ppm) observed in cation **8**, i.e. the only species with aliphatic (Bu') substituents on the phosphido ligand, is noteworthy. The same bridging moiety, $\mu\text{-PBU}'_2$, resonates at low field (160 δ) also in the slightly different hydride $[(\text{Ph}_3\text{P})(\text{H})\text{Pt}(\mu\text{-PBU}'_2)(\mu\text{-H})\text{Pt}\{(\text{Bu}')_2\text{P-C}(\text{Me})_2\text{-CH}_2\}]$ [7]. However, similar shifts have also been observed in the derivatives $[\text{P}_4\text{Pt}_2(\mu\text{-H})(\mu\text{-PPh}_2)]$ ($\text{P} = \text{Ph}_2\text{POH-OPPh}_2$) reported by van Leeuwen et al. [9].

As inferred from the $^1J_{\text{PtH}}$ value (325 Hz), in complex **3** the ligand X *trans* to the bridging hydride should have a rather great *trans* influence, comparable to that of a terminal hydrido or of a carbon donor, only the latter being considered in our case. Taking into account that compound **3** is formed both in the reaction of $[\text{Pt}_2(\text{dppb})_2(\text{H})_3]^+$ with styrene and ethylene, the X ligand cannot originate from the organic substrate. In a separate experiment it was checked also that under the same experimental conditions, but in absence of styrene or ethylene, the trihydrido complex, $[\text{Pt}_2(\text{dppb})_2(\text{H})_3]^+$, is recovered quantitatively after 1 week stirring in CH_2Cl_2 solution. Even the μ -alkylidene, μ -hydrido complex, **1**, is unaffected after a month in the same solvent.

Table 1
Comparison of selected multinuclear NMR data ^a of $[\text{Pt}_2(\text{P-P})_2(\mu\text{-H})(\mu\text{-CHCH}_2\text{R})]^+$ complexes

Compound	^1H					^{13}C			^{31}P			^{195}Pt
	$\mu\text{-CH}$	$\mu\text{-H}$	$^1J_{\text{PtH}}$	$^2J_{\text{PHtrans}}$	$^2J_{\text{PHcis}}$	$\mu\text{-CH}$	$^1J_{\text{CPt}}$	CH_2R	<i>trans</i> C	$^1J_{\text{PPt}}$	$^3J_{\text{PPt}}$	
1	4.8	-2.8	557	76	11	138.8 ^b	486	46.1	1.6	2179		-5542
2^d	4.4	-2.3	561	75	12	139.9 ^c	462	27.1	21.8 ^c	4495	203	-5611
									21.1 ^f	4532	200	
4	^g	-0.35	578	76	7.8	124.5	518	48.4	39.8	2082		-5580
5	4.9	-3.3	566	79	13	135.8	^g	44.5	48.2	4350	173	
									11.9	2403	^g	
									22.2	4690	230	

^a Solvents: **1** and **2**, CDCl_3 ; **4** and **5**, CD_2Cl_2 ; δ in ppm; J in Hz.

^b Tentatively assigned by comparison of $^{13}\text{C}\{^1\text{H}\}$, $^{13}\text{C}\{^1\text{H}, ^{31}\text{P}\}$ and JMOD spectra.

^c J_{PP} : 40 and 10 Hz.

^d From mixture **2+3**.

^e From heterocorrelate $^1\text{H}/^{13}\text{C}$.

^f J_{PP} : 39 and 8 Hz.

^g Not reported.

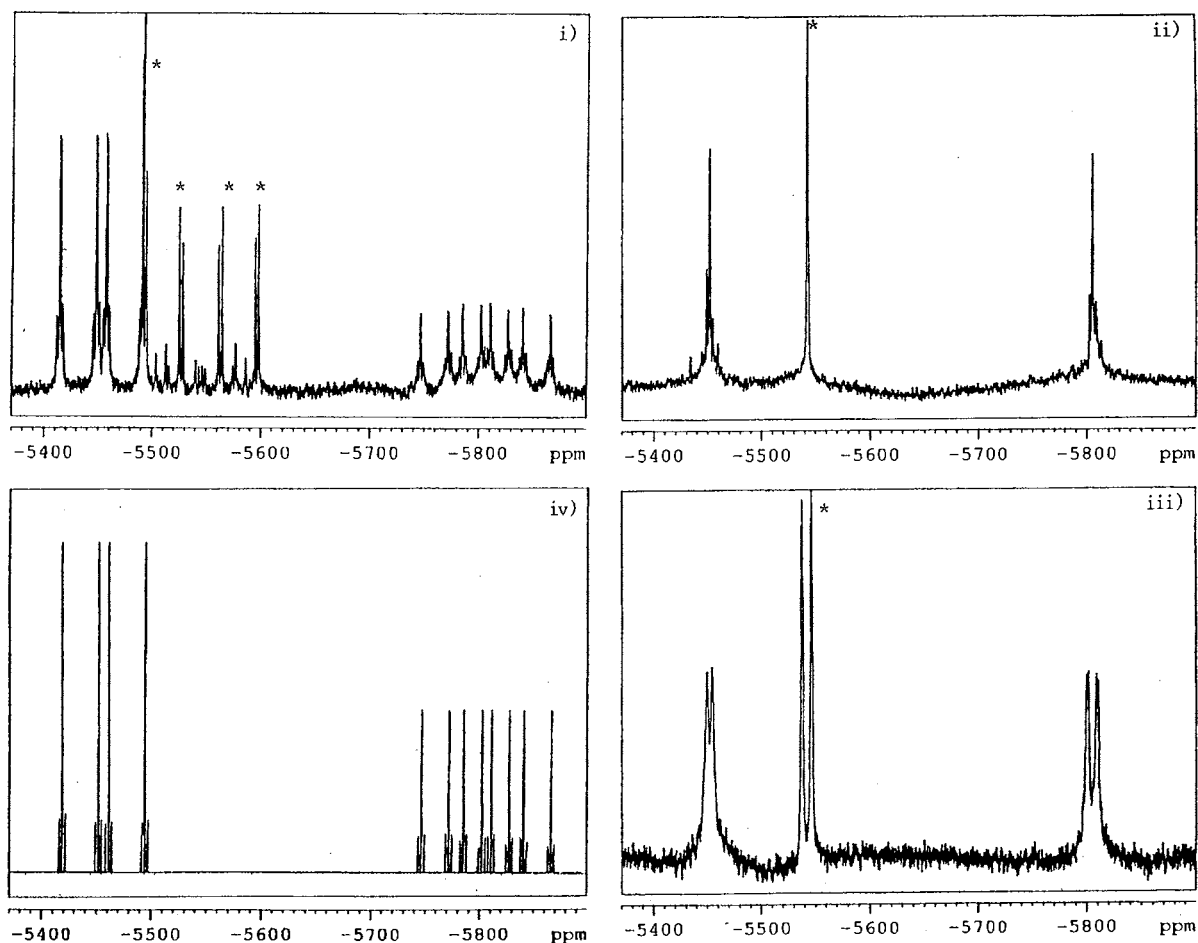

Fig. 3. ^{195}Pt -NMR spectra of mixture **1**+**3**. (i) $^{195}\text{Pt}\{^1\text{H}\}$; (ii) $^{195}\text{Pt}\{^1\text{H},^{31}\text{P}\}$; (iii) $^{195}\text{Pt}\{^{31}\text{P}\}$; (iv) simulated spectrum; * resonance of compound **1**.

Table 2
 ^1H , $^{31}\text{P}\{^1\text{H}\}$, and $^{195}\text{Pt}\{^1\text{H}\}$ -NMR: selected data of cations **3**, **6**–**8**

Cation	^1H hydrido region				$^{31}\text{P}\{^1\text{H}\}$								Reference
	δ	$^1J_{\text{Pt}^1\text{H}}$	$^1J_{\text{Pt}^2\text{H}}$	$J_{\text{P}^4\text{H}}$	δ_{P^1}	$^1J_{\text{P}^1\text{P}^1}$	$^1J_{\text{P}^1\text{P}^2}$	$^1J_{\text{P}^4\text{P}^1}$	$^1J_{\text{P}^2\text{P}^1}$	$^1J_{\text{P}^3\text{P}^2}$	$^2J_{\text{P}^1\text{P}^3}$	$^2J_{\text{P}^1\text{P}^2}$	
3 ^a	−7.0	574	325	93	118 ^b	1644	2185	3593	2505	2786	328	238	
6a ^c	−6.5	600	324	98	117	1798	2257	3785	2509	2895	324	245	[6a]
6b ^d	−6.5	597	330	94	117	1800	2250	3787	2509	2889	324	244	[6b]
7 ^d	−6.6	595	332	95	117	1818	2224	3818	2519	2885	334	248	[6b]
8 ^c	−7.3	584	356	92	196	1730	2106	3470	2114	2590	257	219	[8]

^a CDCl_3 solutions; $^{195}\text{Pt}\{^1\text{H}\}$: −5805 (Pt_1), −5452 (Pt_2), 1 or $^2J_{\text{PtPt}} \approx 360$ Hz.

^b $^2J_{\text{P}^1\text{P}^4} = 17$ Hz.

^c CD_2Cl_2 , solutions; **6a** $^{195}\text{Pt}\{^1\text{H}\}$ at 263 K: −5641 (Pt_1), −5349 (Pt_2), 1 or $^2J_{\text{PtPt}} \approx 500$ Hz.

^d In $\text{THF}-d_8$.

It follows that the new carbon ligand can arise only from the chelating diphosphine: due to the lack of any suggestion of a C–C breaking in the aliphatic chain, this process must imply a P–C bond cleavage, giving as a ligand the complementary fragment of the phosphido moiety. Two cases must be considered which involve either the bond of a phenyl substituent, i.e. a P–C(sp^2) bond, or the aliphatic chain, i.e. a P–C(sp^3)

bond. Two different types of ligands can be originated: a phosphido–phosphine, $\text{PPh}(\text{CH}_2)_4\text{PPh}_2$, or a hybrid (P–C), (*n*-butyl)diphenylphosphino moieties, respectively.

In the former case, in principle the new μ -phosphido ligand linked to a terminal phosphino group may adopt either a *cis* or a *trans* arrangement, giving rise to isomers **A** and **B**, or **C**, respectively.

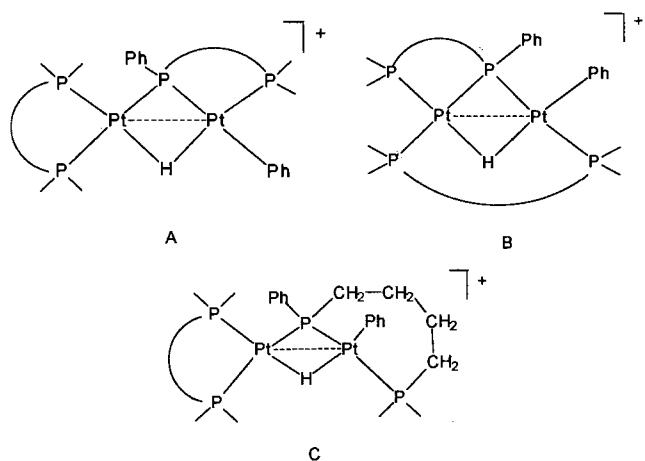

Isomer **A**, which as well as **B** is reminiscent of Meek-type compounds $[\text{MX}(\text{PhP}(\text{CH}_2)_n\text{PR}_2)_2]$ ($\text{M} = \text{Pt}(\text{II}), \text{Pd}(\text{II})$) [14], must be excluded as it does not fulfil the requirements of the molecular skeleton: in fact the NMR data impose two P atoms (P_2 and P_3) *trans* to the μ -phosphido and *cis* to the μ -hydrido ligands. Isomers **B** and **C** fit these structural requirements, but exhibit coordination modes at least unusual for the dppb ligand.

On the contrary, if the cleavage involves a $\text{P}-\text{C}(\text{sp}^3)$ bond, only one species, **D**, can be envisaged:

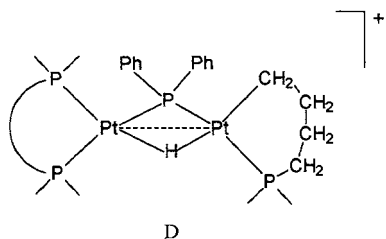

Despite the large variety of NMR experiments, including two-dimensional heterocorrelate $^1\text{H}/^{13}\text{C}$ and $^1\text{H}/^{31}\text{P}$ spectra, carried out to understand the identity of the X ligand on Pt_2 , unquestionable evidence for the presence of a $\text{Pt}-\text{CH}_2$ bond has not been obtained.

On the contrary, the overall set of ^{13}C -NMR data shows in the aromatic region a resonance (144.5δ) not observed in the case of the μ -alkylidene derivative **1**, attributable to a quaternary carbon atom with large couplings to ^{195}Pt and ^{31}P nuclei ($^1J_{\text{PtC}} = 1018$; $^2J_{\text{PC}} = 62$ Hz), suggesting the presence of a $\text{Pt}-\text{Ph}$ bond [15]. Accordingly, a CH resonance at 137.2δ ($^2J_{\text{PtC}} = 32$ Hz) would be assigned to the ortho-carbon atoms of a coordinated phenyl group (C_{meta} : 127.7δ , $^3J_{\text{PtC}} = 36$ Hz; C_{para} : 121.5δ).

Although only a X-ray crystal structure determination might provide a definite answer on the nature of the X ligand, on the whole the spectroscopic data suggest that the cleavage likely occurs on a $\text{P}-\text{C}(\text{sp}^2)$ bond.

3. Final remarks

Two new μ -hydrido, μ -alkylidene cations, **1** and **2**, have been obtained according to the reaction which afforded the first example of these platinum derivatives, complex **4**, and exhaustively characterized. The spectroscopic data are fully comparable with those of the two homologues, **4** and **5**, characterized by X-ray structures [4,5]. This indicates that our synthetic approach is a useful access to rare platinum derivatives with a variety of phosphino ligands and unsaturated substrates.

At variance, the formation of complex **3** is observed only with the dppb ligand [16], i.e. in the case of a seven-membered ring: the reaction is not straightforward, the activation of olefins being accompanied by a $\text{P}-\text{C}$ bond cleavage in the chelating diphosphine.

4. Experimental

4.1. General procedure

Styrene (Fluka) was distilled and purity checked by GC-MS before use; ethylene was used as received from SIAD. The platinum complex $[(\text{dppb})_2\text{Pt}_2(\text{H})_3][\text{BF}_4]$ was prepared as previously reported [2b]. Solvents were distilled prior to use. Evaporation was always carried out under reduced pressure. The analytical samples were pumped to constant weight (room temperature, ca. 0.1 Torr). The elemental analyses were performed by the Microanalytical Laboratories of the University of Milan.

The infrared spectra were recorded on a Jasco FT/IR 420 spectrometer. NMR spectra were recorded in CDCl_3 solutions on a Bruker AC 200 spectrometer, operating at 200 (^1H), 81.0 (^{31}P), 50.3 (^{13}C) and 43.0 MHz (^{195}Pt), respectively. Homonuclear ($^1\text{H}/^1\text{H}$), and heteronuclear ($^1\text{H}/^{31}\text{P}$) selective decoupling experiments, and $^{13}\text{C}\{^1\text{H},^{31}\text{P}\}$, ^{13}C JMOD, $^{195}\text{Pt}\{^1\text{H},^{31}\text{P}\}$ spectra were performed on a Bruker DRX 300 Avance instrument; the one bond and long-range $^{13}\text{C}-^1\text{H}$ inverse correlation, and $^{31}\text{P}-^1\text{H}$ inverse correlation experiments were performed on a Varian 500 spectrometer. The shift values are given in ppm from the usual standards; δ ^{195}Pt are referred to external Na_2PtCl_6 aqueous solution.

Mass spectra were recorded on a VG-7070 EQ spectrometer equipped with a PDP 11/73 data system and operating under FAB conditions with 3-nitro-benzyl alcohol (from Fluka) as matrix, bombarding the solutions with 8 keV Xe atoms; the m/z values are referred to ^{195}Pt .

4.2. Syntheses of compound **1** and mixtures **1** + **3** and **2** + **3**

The products have been obtained as follows for a typical experiment with styrene. The reaction times have

been established by monitoring the disappearance of the starting platinum hydride (IR spectra).

Occasionally in the crude mixtures **1** + **3**, a minor species with a NMR imprint similar to **3** ($\delta_{\text{Pt}}: -4.75$, $^2J_{\text{PtH}} = 161$ Hz; $\delta_{\text{P}}: 129$, $^2J_{\text{PPtrans}} = 269$ Hz) has been observed.

A solution of $[\text{Pt}_2(\text{dppb})_2(\text{H})_3][\text{BF}_4]$ (300 mg; 0.22 mmol) and freshly distilled styrene (1.5 ml; 13.1 mmol) in CH_2Cl_2 (20 ml) was stirred vigorously for a week. Addition of Et_2O (ca. 50 ml) to the pale yellow solution gave a mixture of compounds **1** and **3** as a white powder (243 mg; **3/1** \approx 1). The mixture was separated by flash chromatography on a silica gel column, with CH_2Cl_2 as eluent: from the first eluate an analytically pure sample of **1** (70 mg) was obtained by addition of Et_2O . From the second eluate, recovered with methanol, the mixture of **1** + **3** was precipitated with Et_2O (120 mg; **3/1** \approx 2). Further attempts to achieve the separation of **1** and **3** by subsequent flash-chromatographies were unsuccessful.

The mixture of compounds **2** and **3** (**3/2** \approx 2.5) has been obtained analogously carrying out the reaction in a pressure bottle charged with ethylene at 2.5 atm. Attempts to separate **2** and **3** following the above procedure or by fractional crystallization failed.

4.2.1. Compound **1**

Anal. Calc. for $\text{C}_{64}\text{H}_{65}\text{P}_4\text{Pt}_2\text{BF}_4$, C = 53.5, H = 4.5; Found C = 53.8, H = 4.8; m.p. 205°C (dec.). IR (Nujol mulls): BF_4 1055 s, br. NMR spectra (CDCl_3): ^1H : δ 6.5–7.5 (m, Ar), 4.8 (m, br, CH), 1.6–3.1 (m, br, CH_2); $^{13}\text{C}\{^1\text{H}\}$: 138.8 (t with satellites, CH, $^1J_{\text{CPt}} = 486$ Hz; $^2J_{\text{CP}} = 63$ Hz), 136–125 (Ar), 46.1 (s br, CH_2 of alkylidene), 31–21 (CH_2 of diphosphine). Hydrido resonance, $^{31}\text{P}\{^1\text{H}\}$ and $^{195}\text{Pt}\{^1\text{H}\}$ see Table 1. FAB MS: $[\text{M}]^+$ 1347 *m/z*, $[\text{M}-\text{C}_8\text{H}_8]^+$ 1243 *m/z*.

4.2.2. Compound **2**

NMR data (CDCl_3): ^1H : δ 7.1–7.5 (m, Ar), 4.4 (m, br, CH), 1.9–2.8 (m, br, CH_2), 0.85 (d, br, CH_3); $^1\text{H}\{^{31}\text{P}\}$: δ 4.4 (q, CH, $J_{\text{HH}} \approx 7.8$ Hz), 0.85 (d, CH_3 , $J_{\text{HH}} \approx 7.8$ Hz), -2.3 (s with satellites, H, $^1J_{\text{PtH}} = 561$ Hz); $^{13}\text{C}\{^1\text{H}\}$: 139.9 (t br with satellites, CH, $^1J_{\text{CPt}} \approx 460$ Hz; $^2J_{\text{CP}} \approx 50$ Hz), 136–127 (Ar), 32–22 (CH_2), 27.1 (CH_3 : from $^1\text{H}/^{13}\text{C}$ heterocorrelate spectra). Hydrido resonance, $^{31}\text{P}\{^1\text{H}\}$ and $^{195}\text{Pt}\{^1\text{H}\}$ see Table 1. FAB MS: $[\text{M}]^+$ 1271 *m/z*, $[\text{M}-\text{C}_2\text{H}_4]^+$ 1243 *m/z*.

4.2.3. Compound **3**

IR (Nujol) 1570m. NMR data (CDCl_3): $^{31}\text{P}\{^1\text{H}\}$: δ 17.1 (P_3 , $^1J_{\text{P3Pt2}} = 2784$ Hz, $^2J_{\text{P3Pt1}} = 42.5$, $^2J_{\text{P3P1}} = 328$ Hz), 11.6 (P_2 , $^1J_{\text{P2Pt1}} = 2505$ Hz, $^2J_{\text{P2Pt2}} = 46$ Hz, $^2J_{\text{P2P1}} = 238$ Hz, $^2J_{\text{P2P4}} = 17$ Hz), 0.94 (P_4 , $^1J_{\text{P4Pt1}} = 3593$ Hz, $^2J_{\text{P4P1}} = 17$ Hz, $^2J_{\text{P4P2}} = 17$ Hz). ^1H and $^1\text{H}\{^{31}\text{P}\}$, hydrido resonance, $^{31}\text{P}\{^1\text{H}\}$, phosphido resonance, and $^{195}\text{Pt}\{^1\text{H}\}$ see Table 2.

Acknowledgements

Financial support from Ministero dell'Università e della Ricerca Scientifica e Tecnologica (MURST 40%) is gratefully acknowledged. We thank Mr Pasquale Illiano (Università di Milano) and Dr Antonio Zuca (Università di Sassari) for their assistance with NMR experiments.

References

- [1] G. Minghetti, G. Banditelli, A.L. Bandini, *J. Organomet. Chem.* 139 (1977) C80.
- [2] e.g. (a) T.H. Tulip, T. Yamagata, T. Yoshida, R.D. Wilson, J.A. Ibers, S. Otsuka, *Inorg. Chem.* 18 (1979) 2239. (b) C.B. Knobler, H.D. Kaesz, G. Minghetti, A.L. Bandini, G. Banditelli, F. Bonati, *Inorg. Chem.* 22 (1983) 2324. (c) M.Y. Chiang, R. Bau, G. Minghetti, A.L. Bandini, G. Banditelli, T.F. Koetzle, *Inorg. Chem.* 23 (1984) 122. (d) D. Carmichel, P.B. Hitchcock, J.F. Nixon, A. Pidcock, *J. Chem. Soc. Chem. Commun.* (1988) 1554. (e) S. Aime, R. Gobetto, A.L. Bandini, G. Banditelli, G. Minghetti, *Inorg. Chem.* 30 (1991) 316. (f) B.S. Haggerty, C.E. Housecroft, A.L. Rheingold, B.A.M. Shaykh, *J. Chem. Soc. Dalton Trans.* (1991) 2175. (g) A.L. Bandini, G. Banditelli, E. Cesarotti, F. Demartin, M. Manassero, G. Minghetti, *Gazz. Chim. Ital.* 124 (1994) 43. (h) D.J. Schwartz, R.A. Andersen, *J. Am. Chem. Soc.* 117 (1995) 4014. (i) L. Mole, J.L. Spencer, S.A. Litster, A.D. Redhouse, N. Carr, A.G. Orpen, *J. Chem. Soc. Dalton Trans.* (1996) 2315. (l) S.P. Millar, M. Jang, R.J. Lachicotte, R. Eisenberg, *Inorg. Chim. Acta* 270 (1998) 363.
- [3] (a) G. Minghetti, A.L. Bandini, G. Banditelli, F. Bonati, *J. Organomet. Chem.* 179 (1979) C13. (b) G. Minghetti, A.L. Bandini, G. Banditelli, F. Bonati, R. Szostak, C.E. Strouse, C.B. Knobler, H.D. Kaesz, *Inorg. Chem.* 22 (1983) 2332. (c) A.L. Bandini, G. Banditelli, M.A. Cinellu, G. Sanna, G. Minghetti, F. Demartin, M. Manassero, *Inorg. Chem.* 28 (1989) 404.
- [4] G. Minghetti, A. Albinati, A.L. Bandini, G. Banditelli, *Angew. Chem. Int. Ed. Engl.* 24 (1985) 120.
- [5] M.A. Zhuravel, D.S. Glueck, L.M. Liable-Sands, A.L. Rheingold, *Organometallics* 17 (1998) 574.
- [6] (a) J. Jans, R. Naegeli, L.M. Venanzi, A. Albinati, *J. Organomet. Chem.* 247 (1983) C37. (b) A.R. Siedle, R.A. Newmark, W.B. Gleason, *J. Am. Chem. Soc.* 108 (1986) 767.
- [7] A.B. Goel, S. Goel, *Inorg. Chim. Acta* 90 (1984) L33.
- [8] P. Leoni, S. Manetti, M. Pasquali, *Inorg. Chem.* 34 (1995) 749.
- [9] P.W.N.M. van Leeuwen, C.F. Roobeek, J.H.G. Frijns, A.G. Orpen, *Organometallics* 9 (1990) 1211.
- [10] (a) P.E. Garrou, *Chem. Rev.* 85 (1985) 171. (b) A.J. Carty, *Pure Appl. Chem.* 54 (1982) 113. For some recent examples and leading references, see e.g.: (c) C. Archambault, R. Bender, P. Braunstein, A. De Cian, J. Fischer, *J. Chem. Soc. Chem. Commun.* (1996) 2729. (d) D.K. Morita, J.K. Stille, J.R. Norton, *J. Am. Chem. Soc.* 117 (1995) 8576. (e) C.-G. Xia, K. Yang, S.G. Bott, M.G. Richmond, *Organometallics* 15 (1996) 4480. (f) J.F. Hartwig, S. Richards, D. Baranano, F. Paul, *J. Am. Chem. Soc.* 118 (1996) 3626. (g) J.A. Cabeza, I. del Rio, V. Riera, S. García-Granda, S.B. Sanni, *Organometallics* 16 (1997) 1743.
- [11] (a) N.W. Alcock, P. Bergamini, T.J. Kempe, P.G. Pringle, *J. Chem. Soc. Chem. Commun.* (1987) 235. (b) P. Bergamini, S. Sostero, O. Traverso, T.J. Kempe, P.G. Pringle, *J. Chem. Soc. Dalton Trans.* (1989) 2017. (c) I.J.B. Lin, J.S. Lai, L.-K. Liu, Y.S. Wen, *J. Organomet. Chem.* 399 (1990) 361. (d) I.J.B. Lin, J.S. Lai, C.W. Liu, *Organometallics* 9 (1990) 530.
- [12] A.J. Carty, F. Hartstock, N.J. Taylor, *Inorg. Chem.* 21 (1982) 1349.

- [13] I.V. Kourkine, M.B. Chapman, D.S. Glueck, K. Eichele, R.E. Wasylishen, G.P. Yap, L.M. Liable-Sands, A.L. Rheingold, *Inorg. Chem.* 35 (1996) 1478.
- [14] (a) D.W. Meek, R.D. Waid, K.D. Tarr, R.M. Kirchner, C.N. Morimoto, *Inorg. Chim. Acta* 64 (1982) L221. (b) R. Glaser, D.J. Kountz, J.C. Gallucci, D.W. Meek, *Inorg. Chim. Acta* 77 (1983) L207. (c) R. Glaser, D.J. Kountz, R.D. Waid, J.C. Gallucci, D.W. Meek, *J. Am. Chem. Soc.* 106 (1984) 6324.
- [15] B.E. Mann, B.F. Taylor, *¹³C-NMR Data for Organometallic Compounds*, Academic Press, New York, 1981.
- [16] A.L. Bandini, G. Banditelli, G. Minghetti, III Co.Gi. Co., Abstracts, 65, Siena, July 1996.