

Versatile reactions of a *para*-bromophenylacetylide iron(II) derivative and X-ray structure of the fluoro analogue. Synthesis of new redox-active organoiron(II) synthons

James Courmarcel^a, Gildas Le Gland^a, Loic Toupet^b, Frédéric Paul^{a,*},
Claude Lapinte^{a,*}

^a UMR CNRS 6509, Organométalliques et Catalyse: Chimie et Electrochimie Moléculaires, Institut de Chimie, Université de Rennes 1, Campus de Beaulieu, 35042 Rennes Cedex, France

^b UMR CNRS 6626, Groupe Matière Condensée et Matériaux, Université de Rennes 1, Campus de Beaulieu, 35042 Rennes Cedex, France

Received 23 October 2002; received in revised form 15 November 2002; accepted 15 November 2002

Abstract

The synthesis of the new $(\eta^2\text{-dppe})(\eta^5\text{-C}_5\text{Me}_5)\text{Fe-C}\equiv\text{C-1,3-(C}_6\text{H}_4\text{X)}$ (**m-2a/2b**; X = F/Br) and $(\eta^2\text{-dppe})(\eta^5\text{-C}_5\text{Me}_5)\text{Fe-C}\equiv\text{C-1,4-(C}_6\text{H}_4\text{I)}$ (**2c**) complexes, as well as the solid-state structure of the known $(\eta^2\text{-dppe})(\eta^5\text{-C}_5\text{Me}_5)\text{Fe-C}\equiv\text{C-1,4-(C}_6\text{H}_4\text{F)}$ (**2a**) complex are described. The catalytic coupling reactions of the bromo complexes with various alkynes were next investigated. Starting from the known $(\eta^2\text{-dppe})(\eta^5\text{-C}_5\text{Me}_5)\text{Fe-C}\equiv\text{C-1,4-(C}_6\text{H}_4\text{Br)}$ complex (**2b**), the synthesis of the $(\eta^2\text{-dppe})(\eta^5\text{-C}_5\text{Me}_5)\text{Fe-C}\equiv\text{C-1,4-(C}_6\text{H}_4\text{)-C}\equiv\text{C-H}$ complex (**6d**) and of the corresponding silyl-protected precursors $(\eta^2\text{-dppe})(\eta^5\text{-C}_5\text{Me}_5)\text{Fe-C}\equiv\text{C-1,4-(C}_6\text{H}_4\text{)C}\equiv\text{C-SiR}_3$ (**6b/6c**; R = ⁱPr/Me) are reported. By use of lithium–bromine exchange reactions on **2b**, the silyl- (**7a**; E = Si; R = Me) and tin- (**7b–7d**; E = Sn; R = Me, Bu, Ph) substituted analogues $(\eta^2\text{-dppe})(\eta^5\text{-C}_5\text{Me}_5)\text{Fe-C}\equiv\text{C-1,4-(C}_6\text{H}_4\text{)ER}_3$ are also isolated. The spectroscopic and electrochemical characterisations of all these new Fe(II)/Fe(III) redox-active building blocks are presented and the electronic substituent parameters for the “ $(\eta^2\text{-dppe})(\eta^5\text{-C}_5\text{Me}_5)\text{Fe-C}\equiv\text{C}$ ” group are determined by means of ¹⁹F-NMR.

© 2002 Elsevier Science B.V. All rights reserved.

Keywords: Aryl halides; Organoiron; Acetylides; Redox-active; Synthesis; Hammett

1. Introduction

We have been engaged for several years in the study of redox-active polynuclear organoiron compounds featuring several electroactive $(\eta^2\text{-dppe})(\eta^5\text{-C}_5\text{Me}_5)\text{Fe}$ units connected to a central aromatic unit via alkynyl linkers [1–8]. Depending on their structure and on the oxidation state of the iron centres, these symmetric molecules exhibit electronic properties potentially useful for the realisation of various molecular-scaled devices [1,2]. As shown in Scheme 1 for dinuclear representatives, compounds like (A) can therefore be envisioned as an aromatic core featuring two identical organoiron(II) or -

iron(III) substituents. Such homopolymetallic complexes are simply obtained following a classic activation–deprotonation synthetic sequence (or “vinylidene route”) from the symmetric bridge precursor and corresponding equivalents of the terminal complex precursors [2,9–16]. More recently, molecules with distinct endgroups, like (B), have also attracted considerable attention [17–19]. Actually, the inherent polarisation of the organic bridge does enlarge the perspectives opened by such organometallic assemblies regarding more specific applications, like second harmonic generation for instance [20–22]. Until now, these heterobimetallic structures were accessed from a non-symmetrical mononuclear synthon like (C). This pivotal building block (C) can often be isolated by reacting an excess of the organic symmetric dialkyne bridge precursor with the complex precursor, as reported for

* Corresponding authors.

E-mail addresses: frederic.paul@univ-rennes1.fr (F. Paul), claudelapinte@univ-rennes1.fr (C. Lapinte).

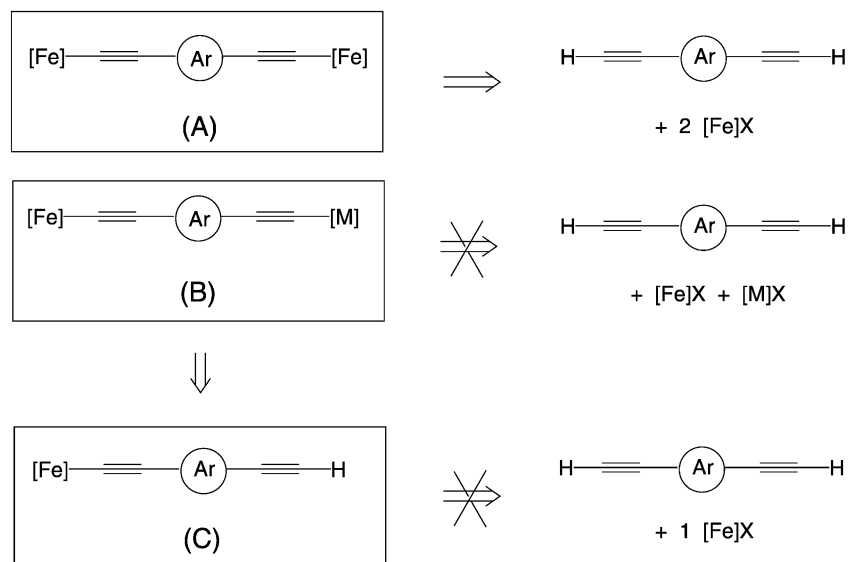

Scheme 1.

several Fe(0) [23], Ru(II) [24–27] or Os(II) [18] complexes. Unfortunately, with the electron-rich $(\eta^2\text{-dppe})(\eta^5\text{-C}_5\text{Me}_5)\text{FeX}$ complexes ([Fe]X in Scheme 1), isolation of the desired mono-metallated complexes (C) proves difficult by this route. Indeed, the selective and stepwise activation of only one of the terminal alkyne functionalities is not observed and formation of a mixture takes place readily, from which (C) cannot be cleanly recovered. In this connection, new and versatile synthetic protocols allowing to isolate compounds like (B) or (C) with the electron-rich $(\eta^2\text{-dppe})(\eta^5\text{-C}_5\text{Me}_5)\text{Fe}$ endgroup are now highly desirable [2].

We have previously developed a “metalla-Sonogashira” coupling reaction, allowing us to specifically append an iron alkynyl fragment onto various substituted bromo-aromatics using this simple and efficient catalytic coupling reaction [28–31]. Bruce et al. [32,33] also had successfully used such an approach to functionalise various terminal diynyl Mo(II) or W(II) complexes. Thus, starting from the organometallic terminal alkynyl complex $(\eta^2\text{-dppe})(\eta^5\text{-C}_5\text{Me}_5)\text{Fe-C}\equiv\text{C-H}$ (**1**) [5,34], the corresponding halogeno-substituted organoiron(II) complexes $(\eta^2\text{-dppe})(\eta^5\text{-C}_5\text{Me}_5)\text{Fe-C}\equiv\text{C-1,4-(C}_6\text{H}_4\text{X)}$ (X = F/Br; **2a/2b**) or $(\eta^2\text{-dppe})(\eta^5\text{-C}_5\text{Me}_5)\text{Fe-C}\equiv\text{C-}m,n\text{-(C}_5\text{H}_4\text{N)Br}$ ($m,n = 2, 5/3, 4$; **3a/3b**) were isolated from the commercial dihalogenoaromatic precursors in a straightforward way [35]. Given the huge synthetic potential of aromatic bromides [36], the Fe(II) alkynyl complexes **2b**, **3a** and **3b** were quite promising as starting organoiron synthons to access structures like (B) or (C). Accordingly, such compounds have been isolated from **3a** and **3b**, via a second Sonogashira coupling at the bromine site. Complex **2b** was apparently less reactive under similar conditions [37]. We now report on simple reactions involving this

species and allowing for the isolation of new organoiron synthons like (C) bearing the electron-rich “ $(\eta^2\text{-dppe})(\eta^5\text{-C}_5\text{Me}_5)\text{Fe}$ ” electroactive centre (see Scheme 2).

2. Results

2.1. Synthesis of halogenated precursors

As reported previously [34], the use of the palladium–copper catalysed coupling reaction in di-*iso*-propylamine starting from **1** and various 1,4-aryl bromides lead to isolation of the corresponding iron alkynyls **2a** and **2b** in very good yields (Scheme 3). These complexes can be isolated pure at the gram scale in one step, the excess of unreacted dihalogeno aryl being removed by washings or sublimation. From a synthetic standpoint, this route compares favourably with the more classic vinylidene route (Scheme 4), starting from $(\eta^2\text{-dppe})(\eta^5\text{-C}_5\text{Me}_5)\text{FeCl}$ (**4**) and pre-formed *para*-bromophenylalkyne [38].

The catalytic coupling reaction can be extended to other commercial dihalogenoaromatic substrates, leading to isolation of the corresponding new *meta*-substituted isomers $(\eta^2\text{-dppe})(\eta^5\text{-C}_5\text{Me}_5)\text{Fe-C}\equiv\text{C-1,3-(C}_6\text{H}_4\text{X)}$ (X = F: **m-2a**; X = Br: **m-2b**; Scheme 3). Under similar conditions, we were however not able to isolate the *para*-iodo analogue $(\eta^2\text{-dppe})(\eta^5\text{-C}_5\text{Me}_5)\text{Fe-C}\equiv\text{C-1,4-(C}_6\text{H}_4\text{I)}$ **2c** completely free from unreacted 1,4-diiodobenzene. Alternatively, when the previous reaction is run with a stoichiometric amount of 1,4-diiodobenzene, some dinuclear $[(\eta^2\text{-dppe})(\eta^5\text{-C}_5\text{Me}_5)\text{Fe-C}\equiv\text{C}]_2\text{-1,4-(C}_6\text{H}_4)$ (**5**) [39] is formed (ca. 5% by LSI-MS) and remains admixed with **2c**. The new

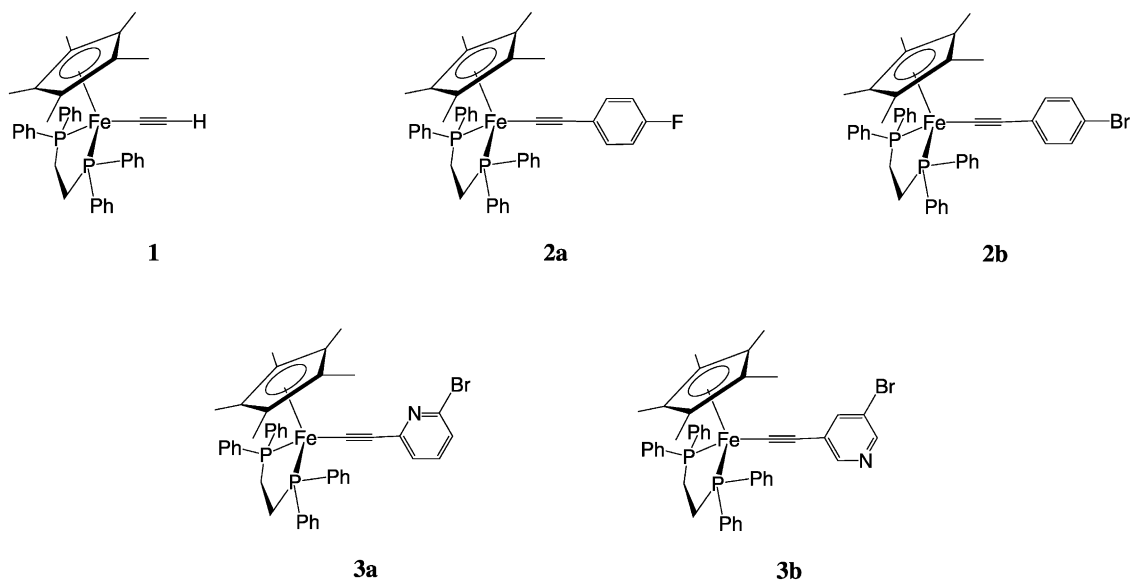

Scheme 2.

complexes **m-2a** and **m-2b**, and **2c** were characterised by the usual methods and exhibit the spectroscopic features expected for such compounds (Table 1).

2.2. X-ray structure of $(\eta^2\text{-dppe})(\eta^5\text{-C}_5\text{Me}_5)\text{Fe-C}\equiv\text{C-1,4-(C}_6\text{H}_4\text{F)}$ (**2a**)

Deep-orange crystals of the complex **2a** were grown and its solid-state structure has been solved (Fig. 1). The complex crystallises in the triclinic *P*1 group, with two molecules in the asymmetric unit (Section 5). Selected bond distances and angles are given in Table 2. The structure shows the classical pseudo-octahedral coordination geometry around the iron(II) centre, with bond distances and angles in the usual range [35]. The *para*-fluorophenyl mean plane is nearly perpendicular to the Fe-Cp* centroid vector, as shown by its dihedral angle with the C39–C40 axis (78.3°). The C42–F1 bond also presents a very classic length (1.364 Å) for such type of bond (ca. 1.363 Å) [40], suggesting no particular interaction with the phenyl ring in this complex. The

distance between the *para*-fluorine atom and the iron centre is 8.68 Å.

2.3. Derivation of Hammett electronic substituent parameters (ESPs) of the “ $(\eta^2\text{-dppe})(\eta^5\text{-C}_5\text{Me}_5)\text{Fe-C}\equiv\text{C-}$ ” fragment

When two equivalents of **1** are used, the formation of the known dinuclear complexes **5** or **m-5** [8,39] is not possible following a one-pot procedure (Scheme 5). Only traces of **5** or **m-5** (around 1%) can be detected in the reaction media by NMR or LSI-MS after 15 h. This explains a posteriori why the isolation of **2b** and **m-2b** is so clean, according to the reaction given in Scheme 3. No really improved formation of **5** takes place when 1,4-diiodobenzene is used in place of 1,4-dibromobenzene. Thus, everything looks as if the reaction would stop after the first coupling and essentially **2b**, **m-2b** or **2c** are present in the reaction media, among unreacted **1** and unidentified minor side products. These observations are very similar to those previously made with **3a** and **3b**

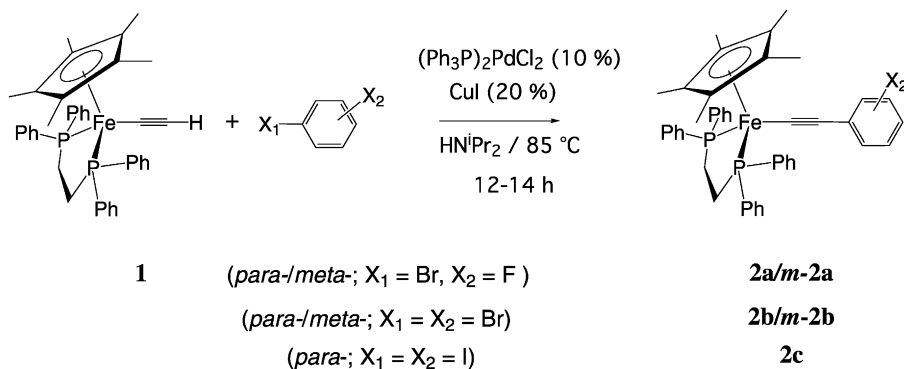

Scheme 3.

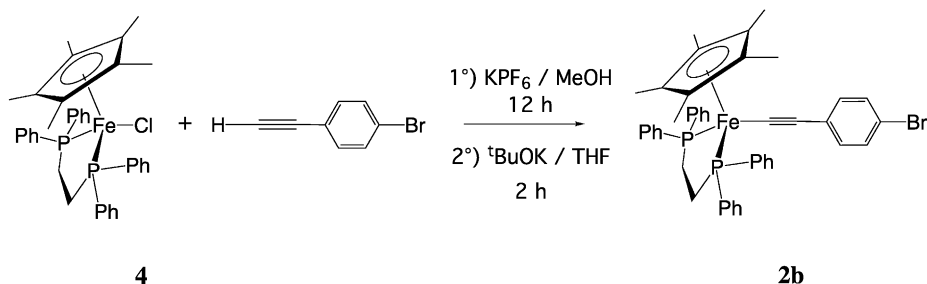

Scheme 4.

[37]. The quasi-absence of di-coupling finds possibly its origin in the electron-releasing effect of the organoiron(II) substituent, which deactivates the halogen atom of the intermediates **2b** and **2c** or *m-2b* toward further oxidative addition (Scheme 6). In order to verify this hypothesis, we have derived experimentally the Hammett ESPs of the “(η²-dppe)(η⁵-C₅Me₅)Fe–C≡C–” fragment when affixed in *meta*- or *para*-positions on the phenyl ring. These data can easily be obtained from the fluorinated analogues **2a** and *m-2a*, by means of ¹⁹F-NMR, using the simple procedure described by Taft et al. [41,42] in 1963 (Section 5.15). Accordingly, the measurement gives values of –0.37 and –0.28 for σ_m and σ_p, respectively, which indeed confirm a relatively strong electron-releasing power for the “(η²-dppe)(η⁵-C₅Me₅)Fe–C≡C–” fragment [36,43]. Such electron-releasing capabilities are stronger than those that would

be exerted by an hydroxy group and explain the low conversion to the dinuclear complexes **5** or *m-5* when the coupling is attempted with the organoiron bromoaryls **2b** or *m-2b*, under the present conditions [29]. In this respect, the disappointing results obtained with the iodo analogue **2c**, expected to be more reactive, are more surprising and suggest that other factors than the purely electronic influence of the organoiron substituent could come in play in this case [44].

2.4. Sonogashira coupling reactions of **2b** with organic alkynes

As had been done for **3a** and **3b** [37], we have used a large excess (10 eq.) of alkyne reactant, in order to overcome the sluggishness of the second Sonogashira coupling on **2b** or *m-2b*. We started our investigations

Table 1
Selected spectroscopic data and yields for (η²-dppe)(η⁵-C₅Me₅)Fe–C≡C–Ar complexes

Compound	Ar	IR ^a ν _{C≡C} (cm ⁻¹)	¹ H-NMR ^b δ _{Cp*} (ppm)	³¹ P-NMR ^b δ _{dpppe} (ppm)	¹³ C-NMR ^b δ _{C≡C} (ppm)	Yield (%)
2a ^c	1,4-(C ₆ H ₄)F	2057	1.53	101.7	136.9 (39 ^d)/118.8	74
<i>m-2a</i>	1,3-(C ₆ H ₄)F	2044	1.50	101.1	143.5 ^e (40 ^d)/119.4 ^e	74
2b ^c	1,4-(C ₆ H ₄)Br	2054	1.50	101.4	142.2 ^e (39 ^d)/119.5 ^e	72
<i>m-2b</i>	1,3-(C ₆ H ₄)Br	2060/2033 ^f	1.58	101.1	144.6 (39 ^d)/119.6	80
2c	1,4-(C ₆ H ₄)I	2052	1.50	101.4	143.5 (40 ^d)/119.4	55
<i>m-6a</i>	1,3-(C ₆ H ₄)C≡C–Ph	2134, 2046	1.52	101.4 ^g	/	67 ^h
6b	1,4-(C ₆ H ₄)C≡C–Si(ⁱ Pr) ₃	2145, 2042	1.49	101.3	146.1 (39 ^d)/122.0, 110.5/91.8	85
6c	1,4-(C ₆ H ₄)C≡C–SiMe ₃	2146, 2038	1.50	101.3	146.5 (39 ^d)/122.1, 108.4/94.2	85
6d	1,4-(C ₆ H ₄)C≡C–H	2105, 2049/2030 ^f	1.50	101.3	146.0 (39 ^d)/121.8, 85.9/78.1(250 ⁱ)	70
7a	1,4-(C ₆ H ₄)SiMe ₃	2053	1.55	101.7	Not obs./121.5	81
7b	1,4-(C ₆ H ₄)SnMe ₃	2055	1.55	101.7	139.4 (38 ^d)/121.4	78
7c	1,4-(C ₆ H ₄)SnBu ₃	2061 ^j	1.54	101.7	/	/
7d	1,4-(C ₆ H ₄)SnPh ₃	2058 ^j	1.54	101.6	141.6 (39 ^d)/120.6	/

^a In CH₂Cl₂/KBr windows unless precised.

^b In C₆D₆ unless precised.

^c Data from [35].

^d ³J_{PC} coupling in Hz.

^e In CDCl₃.

^f Fermi coupling, see [52].

^g In CD₂Cl₂.

^h Spectroscopic yield.

ⁱ ¹J_{CH} coupling in Hz.

^j In Nujol suspension/KBr windows.

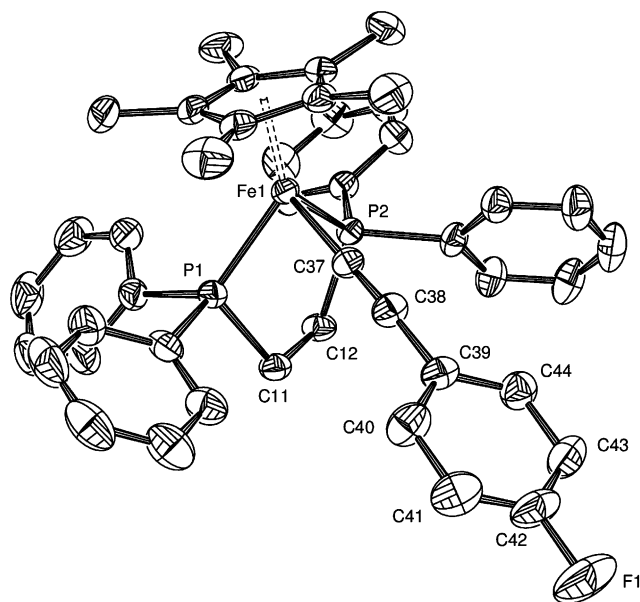

Fig. 1. Solid-state structure of $(\eta^2\text{-dppe})(\eta^5\text{-C}_5\text{Me}_5)\text{Fe-C}\equiv\text{C-1,4-(C}_6\text{H}_4\text{F)}$ (**2a**).

Table 2

Selected bond lengths (Å) and angles (°) for $(\eta^2\text{-dppe})(\eta^5\text{-C}_5\text{Me}_5)\text{FeC}\equiv\text{C-1,4-(C}_6\text{H}_4\text{F)}$ (**2a**)

Selected bond lengths

Fe–Cent. ^a (Cp*)	1.740	C40–C41	1.386(4)
Fe–P1	2.1877(8)	C41–C42	1.352(5)
Fe–P2	2.1955(11)	C42–C43	1.377(5)
Fe–C37	1.902(2)	C43–C44	1.394(4)
C37–C38	1.217(3)	C44–C39	1.393(4)
C38–C39	1.444(3)	C42–F1	1.364(4)
C39–C40	1.406(4)		

Selected bond angles

P1–Fe–P2	86.51(3)	C40–C39–C44	116.8(2)
P1–Fe–C37	82.76(7)	C41–C42–C43	122.3(3)
P2–Fe–C37	86.46(7)	C41–C42–F1	119.3(3)
Fe–C37–C38	179.4(2)	C43–C42–F1	118.4(3)
C37–C38–C39	175.3(2)	Fe–Cent. ^a (Cp*)/C39–C40	73.3 ^b

^a Centroid vector.

^b Dihedral angle.

with the least deactivated *meta*-bromo complex **m-2b** (Scheme 7). Commercial phenylacetylene was preferred for the testing procedure, since **1** complicates the purification and analysis procedures. Following the usual work up, ca. 67% of coupled product **m-6a** is formed after 15 h under reflux admixed with unreacted **m-2b** (27%) and traces of an unidentified complex (6%). The new complex $(\eta^2\text{-dppe})(\eta^5\text{-C}_5\text{Me}_5)\text{Fe-C}\equiv\text{C-1,3-(C}_6\text{H}_4\text{)C}\equiv\text{C-Ph}$ (**m-6a**) could be characterised by spectroscopic methods (Table 1) and LSI-MS. Its new alkyne stretch shows up very weakly in infrared at

2135 cm^{-1} . This evidences that the quasi-quantitative replacement of the second bromine atom by an alkynyl substituent in **m-2b** is envisionable using a Sonogashira coupling procedure, but remains difficult, since largely disfavoured by kinetics. Purification of **m-6a** was not attempted and we focused on Sonogashira couplings between **2b**, the *para*-substituted analogue of **m-2b**, and silylated alkynes (Scheme 8). Indeed, *para*-substitution is much more attractive when a strong interaction is sought with the organoiron(II) substituent, while silylated alkynes are potential precursors of terminal alkynes [45,46].

After optimisation of these reactions, the desired new complexes $(\eta^2\text{-dppe})(\eta^5\text{-C}_5\text{Me}_5)\text{Fe-C}\equiv\text{C-1,4-(C}_6\text{H}_4\text{)C}\equiv\text{C-SiR}_3$ ($\text{R} = {}^i\text{Pr/Me}$; **6b/6c**) could be quantitatively isolated from **2b** after 40–64 h, using a fivefold excess of organic alkyne (Scheme 8). The compounds were obtained pure after the usual work up, based on ³¹P- and ¹H-NMR data, and were characterised by LSI-MS. As for **m-6a**, the presence of the new alkynyl substituent in **6b** and **6c** does also give rise to a weak additional mode in the infrared region corresponding to the organic alkynyl stretch, and to characteristic signals in ¹³C-NMR (Table 1). Importantly, given the volatility of trimethylsilylacetylene, the corresponding coupling reaction was performed in a sealed vessel and care must be taken to prevent explosion hazards by use of a screening shield.

Complex **6c** could also be isolated with 78% yield by performing a metalla-Sonogashira coupling between **1** and the pre-synthesised 1-(*para*-bromophenyl)-2-trimethylsilylacetylene (Scheme 9). However, on synthetic grounds, given that the organic alkyne reactant is used in excess in both cases, our former approach (Scheme 8) is more interesting since **6c** is much more readily purified from volatile trimethylsilylacetylene than from 1-(*para*-bromophenyl)-2-trimethylsilylacetylene.

The silylated alkynyl substituent in either **6b** or **6c** can be removed using classic deprotection sequences to give the terminal alkynyl complex $(\eta^2\text{-dppe})(\eta^5\text{-C}_5\text{Me}_5)\text{Fe-C}\equiv\text{C-1,4-(C}_6\text{H}_4\text{)C}\equiv\text{C-H}$ (**6d**; Scheme 10) [47–49]. The tris(*iso*-propyl)silyl substituent in **6b** is quite robust and deprotection has to be performed with equimolar amounts of tetrabutylammonium fluoride (TBAF) at 50 °C. The purification of **6d** from the TBAF residual salts proves, however, rather difficult.

In this respect, the trimethylsilyl-substituted complex **6c** is a better precursor to access **6d**. Deprotection takes place readily with potassium carbonate under milder conditions and purification of the product is also much easier. After toluene extraction and pentane washings, pure samples of **6d** can be obtained, as indicated by ³¹P- and ¹H-NMR. This compound was characterised by LSI-MS and the usual spectroscopic techniques (Table 1). The presence of a terminal hydrogen atom is evidenced by specific signatures in infrared (ν_{CH} at

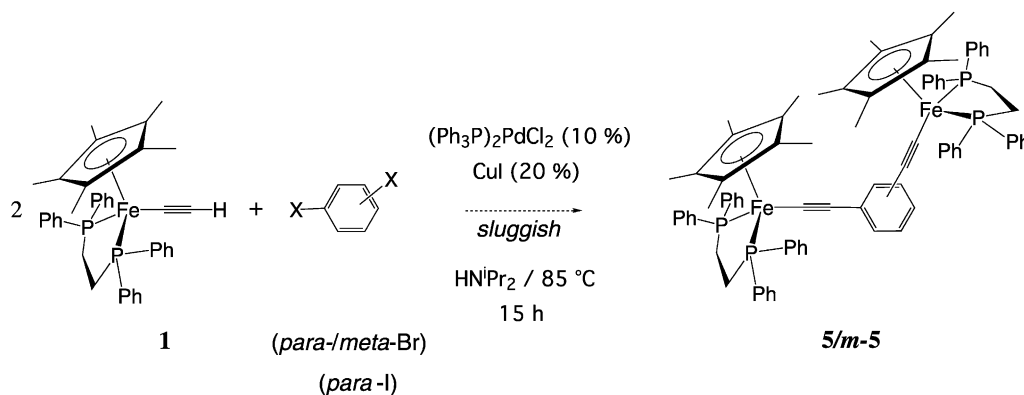

Scheme 5.

3307 cm^{-1}), in $^1\text{H-NMR}$ (δ_{H} at 2.84 ppm) and $^{13}\text{C-NMR}$ ($^1J_{\text{CH}}$ of 250 Hz for $\equiv\text{C-H}$), and by the disappearance of the trialkylsilyl-substituent signals. The 50 cm^{-1} infrared shift of the additional alkyne stretch between **6b** or **6c** and **6d** is also diagnostic of the removal of the trimethylsilyl group.

2.5. Halogen–lithium exchange reactions of **2b** and reaction with electrophiles

In the previous couplings, **2b** behaves as an electrophilic synthon, the bromine substituent being replaced by an alkynyl nucleophile. From a synthetic standpoint, it was also interesting to be able to use **2b** as a nucleophilic synthon. In principle, this is possible if a bromine–lithium exchange reaction can be realised with **2b** [36]. Such a reaction has seldom been performed on organometallic substrates [50]. It was notably used by

Lin and co-workers [51] with closely related Ru(II) acetylides, but apparently failed in some instances. This is not surprising, since the anionic intermediate (**2⁻**) is expected to be very reactive, especially given the electron-releasing capability exerted by the organoiron(II) substituent. We have, therefore, not attempted to isolate the lithium salt of **2⁻** and have preferred to trap it, in situ, with chlorotrimethylsilane at $-80\text{ }^\circ\text{C}$ (Scheme 11).

Under such conditions, the formation of **2⁻** takes place since the new complex $(\eta^2\text{-dppf})(\eta^5\text{-C}_5\text{Me}_5)\text{Fe-C}\equiv\text{C-1,4-(C}_6\text{H}_4\text{)-SiMe}_3$ (**7a**) is isolated with good yields and was fully characterised by spectroscopic methods and LSI-MS (Table 1). We next decided to extend this protocol to various tin electrophiles (**7b** and **7d**), since tin compounds should preserve an anion-like reactivity at the *para*-carbon site [36]. The corresponding complexes $(\eta^2\text{-dppf})(\eta^5\text{-C}_5\text{Me}_5)\text{Fe-C}\equiv\text{C-1,4-(C}_6\text{H}_4\text{)-SnR}_3$

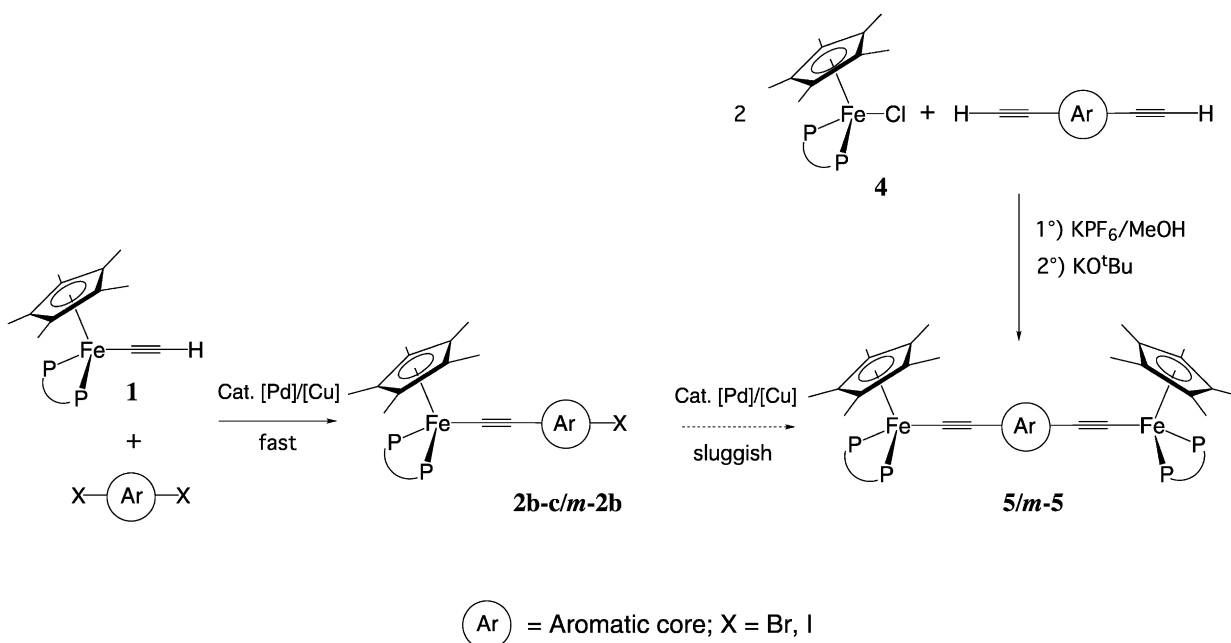

Scheme 6.

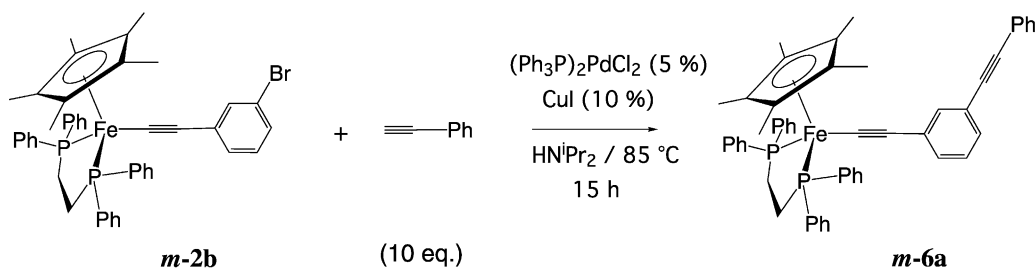

Scheme 7.

(R = Me: **7b**; R = Bu: **7c**; R = Ph: **7d**) were isolated in a similar fashion (Scheme 11). The reaction works apparently similarly in all cases, as revealed by infrared, LSI-MS and NMR spectroscopy (Table 1), but leads to a tractable product only in the case of **7b**. Indeed, **7b** can be isolated pure as a brown powder, while **7c** and **7d** have a gummy consistency limiting their handling and evaluation of the corresponding yields. The presence of the tin substituent in **7b** is also evidenced by the characteristic signal at -30.1 ppm in $^{119}\text{Sn}\{^1\text{H}\}$ -NMR.

3. Discussion

Recent investigations on mononuclear model complexes have shown that the alkynyl bridge mediates very efficiently the electronic interaction between the metal-based d-orbitals and the π - and σ -manifolds based on the aromatic group, regardless of the oxidation state of the metal [52–54]. Accordingly, the derivation of the Hammett ESPs effected here for the metal fragment by ^{19}F -NMR from **2a** and **m-2a** gave rather large and negative values on the Hammett scale. The organoiron substituent on the halide complexes **2a** and **2c** or **m-2a** and **2b** behaves apparently as an electron-releasing group via both the π - and σ -molecular orbital manifolds, as suggested by the values of the inductive ($\sigma_{\text{I}} = -0.20$) and resonant ($\sigma_{\text{R}} = -0.17$) contributions.

Some doubts have been raised regarding the appropriateness of NMR spectroscopy for obtaining the ESPs of metallic substituents bonded directly to the phenyl ring, given the possibility to have a specific interaction between the metal centre and the nucleus used as a

probe, when they are in close proximity [55–57]. Indeed, a transition metal nucleus could exert an unwanted influence on the paramagnetic term in the shift of the fluorine atom [56,58–60]. However, with **2a**, the crystal structure data indicate that the iron and fluorine atoms are more than 8 Å apart, and also suggest that this distance will be more than 7 Å for the *meta* isomer **m-2a**. These distances seem sufficient for neglecting any of the unwanted effects on the fluorine shift previously envisioned.

Accordingly, the values presently found for “ $(\eta^2\text{-dppe})(\eta^5\text{-C}_5\text{Me}_5)\text{Fe-C}\equiv\text{C}$ ” are in the range reported by Stewart and Treichel [61] for various organometallic complexes. They also appear consistent with the value of σ_{p} reported for the “ $(\text{PPh}_3)_2(\eta^5\text{-C}_5\text{Me}_5)\text{Ru}$ ” fragment (-0.81) by Sato and et al. [62], and obtained from electrochemical measurements. Notably, the electron-releasing power for these σ -alkynyl complexes is much more pronounced than for the *para*- or *meta*-ferrocenyl substituents (-0.18 and -0.15 , respectively), where the metal centre is connected to the organic substrate in a π -fashion [63].

Aryl bromides presenting transition metal complexes as substituents are increasingly used as reactants in related coupling reactions to access larger metal-containing architectures [50,64–73]. Thus, from a synthetic point of view, the electronic effect exerted by the “ $(\eta^2\text{-dppe})(\eta^5\text{-C}_5\text{Me}_5)\text{Fe-C}\equiv\text{C}$ ” substituent is very interesting, since mononuclear organoiron(II) aryl bromides like **2b** or **m-2b** can easily be accessed in one step and isolated pure from the corresponding commercial dibromo precursors. Actually, reports on acetylide complexes possessing a halogenated aryl group are scarce

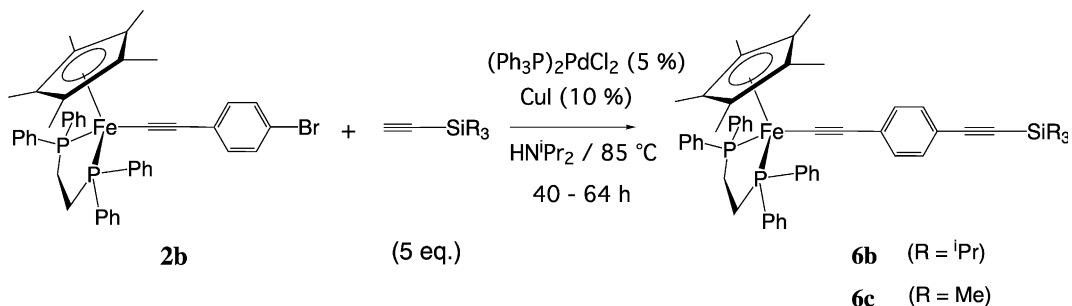

Scheme 8.

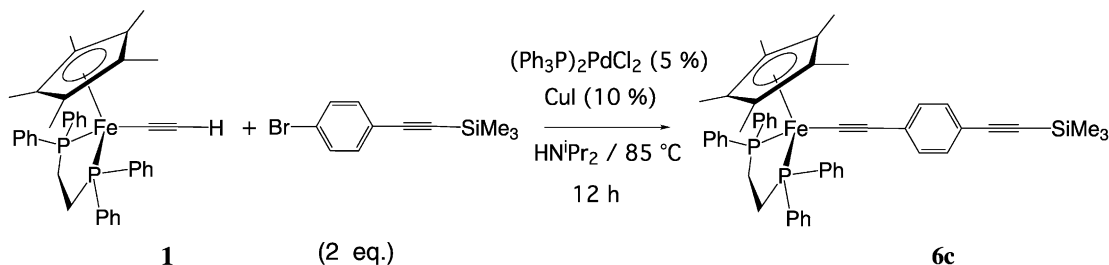

Scheme 9.

[44,74], and preparations of some of these compounds appear less attractive from a strictly synthetic point of view [74]. We also show here that the remaining bromine atom in these organometallic synthons remains reactive and that **2b** can be used in classic coupling reactions undergone by organic aryl bromides, similarly to what has been previously stated with **3a** and **3b** [37]. Thus, the reaction reported in Scheme 3 constitutes an efficient mean to discriminate the two halogen functions and allows for further functionalisation of the iron-substituted phenyl moiety, as illustrated by the synthesis of **6b** and **6c**. In this connection, **2b** and *m*-**2b** can be considered as new organometallic synthons that can be opposed to various nucleophiles in Sonogashira couplings. However, as established during this work, the electron-releasing power of iron(II) alkynyl substituent limits somewhat the synthetic scope of such a reaction, since rather harsh conditions, high catalyst loadings and excess alkyne substrate are needed for a quantitative coupling to take place. Notably, closely related Sonogashira couplings were recently reported with a *para*-iodo phenylacetylide complex of Ru(II) by Humphrey and co-workers [44]. Interestingly, these reactions take place under much milder conditions, suggesting an increased reactivity of the corresponding *para*-iodo $\text{Cl}(\eta^2\text{-dppe})_2\text{Ru}-\text{C}\equiv\text{C}-1,4\text{-}(\text{C}_6\text{H}_4\text{I})$ complex relative to **2c**.

In contrast, **6d** or **7b** can be envisioned as nucleophilic organoiron(II) synthons and their coupling reactions

should not suffer from the electronic effect of the organoiron(II) group. The synthetic scope that species like **6d** ((C) in Scheme 1) possess to access unsymmetrical di- or polynuclear complexes have recently been underlined by several groups for related ruthenium(II) or osmium(II) acetylides [17–19,44]. Alternatively, a species like **7b** should also present a very rich chemistry as nucleophile in catalytic Stille couplings [75–77].

Finally, it is worth recalling that all Fe(II) acetylides synthesised during this work are redox-active and present a chemically reversible oxidation potential well above that of the standard calomel electrode (SCE) used as reference (Table 3). The potential shifts induced by replacement of the aryl *para*-bromo substituent are rather slight (ca. 65 mV), but are in line with the electron-releasing capabilities of the new substituents ($\text{SnMe}_3\text{SnBu}_3 > \text{SnPh}_3\text{SiMe}_3 > \text{C}\equiv\text{C}-\text{Si}^i\text{Pr}_3 > \text{C}\equiv\text{C}-\text{SiMe}_3 > \text{C}\equiv\text{C}-\text{H}$), while the seemingly counter-intuitive order found for the halogen substituents ($\text{F} > \text{Br} > \text{I}$) has already been observed and discussed for the related series of $(\eta^2\text{-dppe})(\eta^5\text{-C}_5\text{Me}_5)\text{FeX}$ complexes ($\text{X} = \text{F}, \text{Cl}, \text{Br}, \text{I}$) [78]. Without surprise [43], the terminal *para*-alkyne renders the oxidation more difficult relative to **2b**, while all other substituents facilitate it, the effect being more prominent for tin derivatives **7b** and **7c**. This is in line with the slight carbanionic character expected the *para*-carbon of the aryl ring. The comparison between **6c** and **7a** also shows that inserting an

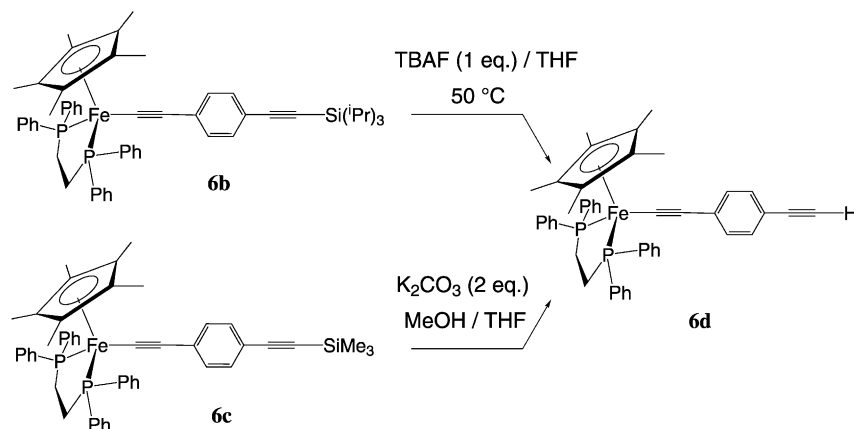

Scheme 10.

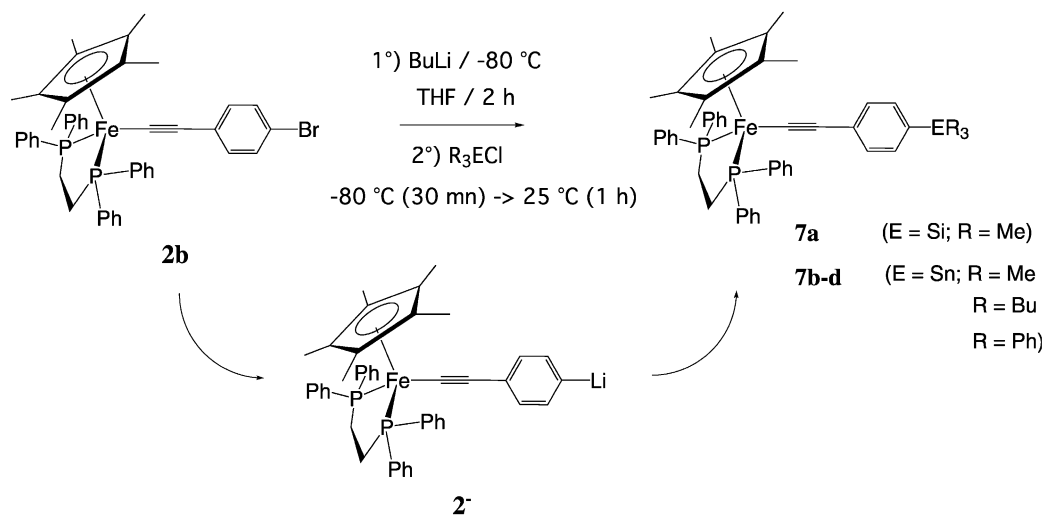

Scheme 11.

acetylenic unit between the aryl ring and trimethylsilyl substituent “decreases” its electronic influence of ca. 30 mV.

4. Conclusions

In this contribution, we have reported efficient synthetic ways to access new organoiron(II) phenylacetylides presenting Br, I, C≡C–H or SnR₃ substituents on the aryl ring and have fully characterised these species. Considering the well-known reactivity of the pre-cited functional groups, these new Fe(II) synthons constitute promising non-symmetric building blocks to access heterobinuclear analogues of **5** and *m*-**5**, but also for

the realisation of larger symmetric or non-symmetric organometallic architectures containing at least one redox-active “(η²-dppe)(η⁵-C₅Me₅)Fe–C≡C–(C₆H₄)” organoiron(II) fragment [2,44].

5. Experimental

Reagent grade tetrahydrofuran (THF), diethylether and *n*-pentane were dried and distilled from sodium benzophenone ketyl prior to use. Acetonitrile was dried on P₂O₅ and distilled over Na₂CO₃ and di-*iso*-propylamine was distilled over NaOH before use. Pentamethylcyclopentadiene was prepared according to the published procedure and other chemicals were used as

Table 3
Electrochemical data ^a for (η²-dppe)(η⁵-C₅Me₅)Fe–C≡C–Ar complexes

Compound	Ar	ΔE _p (V)	E ₀ (V) ^b	i _c /i _a	References
2a	1,4-(C ₆ H ₄)F	0.08	−0.15	1	[35]
<i>m</i> - 2a	1,3-(C ₆ H ₄)F	0.09	−0.11	1	This work
2b	1,4-(C ₆ H ₄)Br	0.08	−0.13	1	[35] ^c
<i>m</i> - 2b	1,3-(C ₆ H ₄)Br	0.09	−0.10	1	This work
2c	1,4-(C ₆ H ₄)I	0.08	−0.12	1	This work
<i>m</i> - 6a	1,3-(C ₆ H ₄)C≡C–Ph	0.08	−0.13	1	This work
6b	1,4-(C ₆ H ₄)C≡C–Si(^{<i>i</i>} Pr) ₃	0.08	−0.14	1	This work
6c	1,4-(C ₆ H ₄)C≡C–SiMe ₃	0.08	−0.12	1	This work
6d	1,4-(C ₆ H ₄)C≡C–H	0.08	−0.11	1	This work
7a	1,4-(C ₆ H ₄)SiMe ₃	0.08	−0.16	1	This work
7b	1,4-(C ₆ H ₄)SnMe ₃	0.12	−0.18	1	This work
7c	1,4-(C ₆ H ₄)SnBu ₃	0.08	−0.17	1	This work
7d	1,4-(C ₆ H ₄)SnPh ₃	0.10	−0.16	1	This work

^a All *E* values in V vs. SCE. Conditions: CH₂Cl₂ solvent, 0.1 M [*n*-Bu₄N⁺][PF₆[−]] supporting electrolyte, 20 °C, Pt electrode, sweep rate 0.100 V s^{−1}. The ferrocene/ferrocenium (Fc/Fc⁺) was used as an internal calibrant for potential measurements [90].

^b E₀ values corrected for Fc/Fc⁺ at 0.460 V vs. SCE in CH₂Cl₂.

^c The value of 0.12 V previously reported was re-determined (0.128 V).

received. All manipulations were carried out under argon atmosphere using Schlenk techniques or in a Jacomex 532 dry box under nitrogen. Transmittance FTIR spectra were recorded using a Bruker IFS28 spectrometer, using a Nernst Globar source and a KBr separator with a DTGS detector ($400\text{--}7500\text{ cm}^{-1}$). The Raman spectra of **m-2b** were obtained by diffuse scattering on a solid sample in a sealed glass tube and recorded in the $100\text{--}3300\text{ cm}^{-1}$ range (Stokes emission) using a Bruker RFS 100 spectrometer with a laser excitation source at 1064 nm. Under the same conditions, **m-2a** presented a strong fluorescence, which precluded the observation of meaningful Raman lines. High-field NMR spectra experiments were performed on a multinuclear Bruker 300 MHz or 200 MHz instrument (AM300WB and 200DPX). Chemical shifts are given in parts per million relative to tetramethylsilane (TMS) for ^1H - and ^{13}C -NMR spectra, CFCl_3 for ^{19}F -NMR spectra, H_3PO_4 for ^{31}P -NMR spectra and SnMe_4 for ^{119}Sn -NMR spectra. Cyclic voltammograms were recorded using a PAR 263 instrument. LSI-MS analyses were done at the "Centre Regional de Mesures Physiques de l'Ouest" (CRMPO) on a high-resolution MS/MS ZabSpec TOF Micromass spectrometer (8 kV). Elemental analyses were performed at the Centre for Microanalyses of the CNRS at Lyon-Solaise, France.

The syntheses of complexes $(\eta^2\text{-dppe})(\eta^5\text{-C}_5\text{Me}_5)\text{Fe-C}\equiv\text{C-H}$ (**1**), $(\eta^2\text{-dppe})(\eta^5\text{-C}_5\text{Me}_5)\text{Fe-C}\equiv\text{C-1,4-(C}_6\text{H}_4\text{X)}$ (**2a** and **2b**; X = F, Br) and $(\eta^2\text{-dppe})(\eta^5\text{-C}_5\text{Me}_5)\text{Fe(Cl)}$ (**4**) have been previously reported [35,79,80], while $\text{Me}_3\text{Si-C}\equiv\text{C-1,3-(C}_6\text{H}_4\text{)Br}$ and $\text{H-C}\equiv\text{C-1,4-(C}_6\text{H}_4\text{)Br}$ were obtained following literature procedures [73,81].

5.1. Synthesis of $(\eta^2\text{-dppe})(\eta^5\text{-C}_5\text{Me}_5)\text{Fe-C}\equiv\text{C-1,4-(C}_6\text{H}_4\text{Br)}$ (**2b**) by the vinylidene route

$(\eta^2\text{-dppe})(\eta^5\text{-C}_5\text{Me}_5)\text{Fe(Cl)}$ (**4**; 1.006 g, 1.610 mmol), NH_4PF_6 (0.270 g, 1.656 mmol) and 4-bromophenylacetylene (0.350 g, 1.930 mmol) were suspended in 40 ml methanol and the solution was stirred 12 h at ambient temperature. The initially green solution turns brown. After removal of the solvent, the orange residue was extracted with dichloromethane and the extract concentrated in vacuo and precipitated with excess *n*-pentane. Several washings with ether yielded the slightly air-sensitive brownish-orange $[(\eta^2\text{-dppe})(\eta^5\text{-C}_5\text{Me}_5)\text{Fe=C=CH}\{1,4\text{-(C}_6\text{H}_4\text{)Br}\}^+][\text{PF}_6^-]$ complex (1.246 g, 1.362 mmol, 85%). MS (positive LSI, 3-NBA, *m/z*) 816 $[(\text{dppe})(\text{C}_5\text{Me}_5)\text{FeC=CH-(C}_6\text{H}_4\text{Br)}]^+$, 7%; 690 $[(\text{dppe})(\text{C}_5\text{Me}_5)\text{FeC}\equiv\text{C(C}_6\text{H}_4)+1]^+$, $\frac{3}{4}$ 1%; 589 $[(\text{dppe})(\text{C}_5\text{Me}_5)\text{Fe}]^+$, 100%). FTIR (KBr/Nujol, ν , cm^{-1}) 1617 (s, Fe=C=C). ^{31}P -NMR (δ , CDCl_3 , 81 MHz, ppm) 87.5 (s, 2P, dppe); -142.9 (septuplet, 1P, $^1J_{\text{PF}} = 712\text{ Hz}$, PF_6). ^1H -NMR (δ , CDCl_3 , 200 MHz,

ppm) 8.10–6.95 (m, 22H, $H_{\text{Ar/dppe}} + H_{\text{ArBr}}$); 6.20 (d, 2H, $^1J_{\text{PF}} = 7.2\text{ Hz}$, H_{ArBr}); 5.02 (broad singlet, 1H, = CH(ArBr)); 3.30 (m, 2H, $\text{CH}_{2\text{dppe}}$); 2.70 (m, 2H, $\text{CH}_{2\text{dppe}}$); 1.59 (s, 15H, $\text{C}_5(\text{CH}_3)_5$). $^{13}\text{C}\{^1\text{H}\}$ -NMR (δ , CDCl_3 , 50 MHz, ppm) 360.4 (t, $^2J_{\text{CP}} = 34\text{ Hz}$, Fe=C=C); 136.0–119.8 (m, Fe=C=CH, $C_{\text{Ar/dppe}} + C_{\text{ArBr}}$); 101.1 (s, $\text{C}_5(\text{CH}_3)_5$); 29.6 (m, $\text{CH}_{2\text{dppe}}$); 10.8 (s, $^1J_{\text{CH}} = 128\text{ Hz}$, $\text{C}_5(\text{CH}_3)_5$). The vinylidene salt (1.246 g, 1.362 mmol) is then stirred 1 h in THF (25 ml), in the presence of excess potassium *tert*-butoxide (0.250 g, 2.212 mmol). After evacuation of the solvent and extraction with toluene, the desired brownish-orange $(\eta^2\text{-dppe})(\eta^5\text{-C}_5\text{Me}_5)\text{Fe-C}\equiv\text{C-1,4-(C}_6\text{H}_4\text{)Br}$ (**2b**) complex is isolated and admixed with a degradation product. Concentration of the extract to 15 ml and subsequent precipitation with *n*-pentane (15 ml) gives **2b** in low yield.

5.2. Synthesis of $(\eta^2\text{-dppe})(\eta^5\text{-C}_5\text{Me}_5)\text{Fe-C}\equiv\text{C-1,4-(C}_6\text{H}_4\text{I)}$ (**2c**)

In a Schlenk tube, 0.400 g of $(\eta^2\text{-dppe})(\eta^5\text{-C}_5\text{Me}_5)\text{Fe-C}\equiv\text{CH}$ (**1**; 0.650 mmol), 0.046 g of $(\text{PPh}_3)_2\text{PdCl}_2$ (0.065 mmol, 10%), 0.025 g of CuI (0.13 mmol, 20%), 0.380 g of 1,4-diiodobenzene (1.15 mmol) and 20 ml of di-*iso*-propylamine are introduced under argon. The reaction mixture is refluxed for 14 h and the amine is removed in vacuum. The dark residue is then extracted with toluene (10 ml) and filtered on a celite pad. Precipitation from the toluene with *n*-pentane (7 ml), followed by filtration and repeated washings with cold acetonitrile ($-30\text{ }^\circ\text{C}$, $2 \times 3\text{ ml}$), then *n*-pentane ($2 \times 5\text{ ml}$), yield the desired $(\eta^2\text{-dppe})(\eta^5\text{-C}_5\text{Me}_5)\text{Fe-C}\equiv\text{C-1,4-(C}_6\text{H}_4\text{I)}$ complex (**2c**) as an orange powder (0.508 g total), admixed with starting 1,4-diiodobenzene (ca. 2 eq.). MS (positive LSI, 3-NBA, *m/z*) 816 $[(\eta^2\text{-dppe})(\eta^5\text{-C}_5\text{Me}_5)\text{FeC}\equiv\text{C(C}_6\text{H}_4\text{I)}]^+$, 15%; 690 $[(\text{dppe})(\text{C}_5\text{Me}_5)\text{FeC}\equiv\text{C(C}_6\text{H}_4)+1]^+$, 5%; 589 $[(\text{dppe})(\text{C}_5\text{Me}_5)\text{Fe}]^+$, 65%). FTIR (KBr/Nujol, ν , cm^{-1}) 2150 (s, Fe-C≡C). ^1H -NMR (200 MHz, C_6D_6 , δ , ppm) 7.92 (m, 4H, $H_{\text{ortho/Ar/dppe}}$); 7.43–6.76 (m, 20H, H_{Ar}); 2.57 (m, 2H, $\text{CH}_{2\text{dppe}}$); 1.80 (m, 2H, $\text{CH}_{2\text{dppe}}$); 1.50 (s, 15H, $\text{C}_5(\text{CH}_3)_5$). $^{13}\text{C}\{^1\text{H}\}$ -NMR (50 MHz, C_6D_6 , δ , ppm) 143.5 (t, $^2J_{\text{CP}} = 40\text{ Hz}$, Fe-C≡C); 140.5–128.0 (phenyls); 120.3 (s, Fe-C≡C); 88.6 (s, $\text{C}_5(\text{CH}_3)_5$); 87.3 (s, C-I); 31.4 (m, $\text{CH}_{2\text{dppe}}$); 11.0 (s, $^1J_{\text{CH}} = 126\text{ Hz}$, $\text{C}_5(\text{CH}_3)_5$).

5.3. Synthesis of $(\eta^2\text{-dppe})(\eta^5\text{-C}_5\text{Me}_5)\text{Fe-C}\equiv\text{C-1,3-(C}_6\text{H}_4\text{F)}$ (**m-2a**)

The reaction was effected as described above from 0.200 g of $(\eta^2\text{-dppe})(\eta^5\text{-C}_5\text{Me}_5)\text{Fe-C}\equiv\text{CH}$ (**1**; 0.325 mmol) and 2.5 eq. of 3-bromofluorobenzene (0.090 ml, 0.812 mmol). The desired complex $(\eta^2\text{-dppe})(\eta^5\text{-C}_5\text{Me}_5)\text{Fe-C}\equiv\text{C-1,3-(C}_6\text{H}_4\text{)F}$ (**m-2a**) was isolated as an orange solid (0.171 g, 0.240 mmol, 74%). Anal. Calc.

for $C_{44}H_{43}F_1P_2Fe_1$: C, 74.58; H, 6.12; F, 2.68. Found: C, 74.05; H, 5.99; F, 2.28%. MS (positive LSI, 3-NBA) m/z 708 ($[(dppe)(C_5Me_5)FeC\equiv C(C_6H_4F)]^+$, 100%); 691 ($[(dppe)(C_5Me_5)FeC\equiv C(C_6H_4)+2]^+$, 5%); 589 ($[(dppe)(C_5Me_5)Fe]^+$, 30%). FTIR (KBr/Nujol, ν , cm^{-1}) 2032 (s, $C\equiv C$). $^{19}F\{^1H\}$ -NMR (δ , C_6D_6 , 188 MHz, ppm) -115.2 (s, C_6H_4F). 1H -NMR (δ , C_6D_6 , 200 MHz) 7.95 (m, 4H, $H_{ortho/Ph/dppe}$); 7.29–6.94 (m, 20H, $H_{Ar/dppe} + H_{ArF}$); 2.57 (m, 2H, CH_{2dppe}); 1.80 (m, 2H, CH_{2dppe}); 1.50 (s, 15H, $C_5(CH_3)_5$). $^{13}C\{^1H\}$ -NMR (δ , $CDCl_3$, 50 MHz, ppm) 163.5 (d, $^1J_{CF} = 242$ Hz, $F-C_{Ar}$); 143.5 (t, $^2J_{CP} = 40$ Hz, $Fe-C\equiv C$); 133.2 (d, $^3J_{CF} = ca. 20$ Hz, $C\equiv C-C_{ArF}$); 139.8–128.0 (m, $8C_{Ar/dppe} + 1 C-H_{ArF}$); 125.1 (d, $^2J_{CF} = ca. 148$ Hz, $C-H_{ortho/ArF}$); 119.4 (s, $Fe-C\equiv C$); 116.9 (d, $^4J_{CF} = ca. 20$ Hz, $^1J_{CH} = 162$ Hz, $C-H_{ArF}$); 110.1 (d, $^3J_{CF} = ca. 21$ Hz, $^1J_{CH} = 165$ Hz, $C-H_{ArF}$); 88.4 (s, $C_5(CH_3)_5$); 31.3 (m, CH_{2dppe}); 10.8 (s, $^1J_{CH} = 126$ Hz, $C_5(CH_3)_5$).

5.4. Synthesis of $(\eta^2-dppe)(\eta^5-C_5Me_5)Fe-C\equiv C-1,3-(C_6H_4Br)$ (**m-2b**)

The reaction was effected as described above for compound **2c** with 2.0 eq. of 3-dibromobenzene (0.150 ml, 1.30 mmol). The desired $(\eta^2-dppe)(\eta^5-C_5Me_5)Fe-C\equiv C-1,3-(C_6H_4Br)$ complex (**m-2b**) is isolated as an orange powder (0.400 g, 0.52 mmol, 80%). MS (positive LSI, 3-NBA) m/z 769 ($[(dppe)(C_5Me_5)FeC\equiv C-(C_6H_4Br)+1]^+$, 70%); 690 ($[(dppe)(C_5Me_5)FeC\equiv C(C_6H_4)+1]^+$, 10%); 589 ($[(dppe)(C_5Me_5)Fe]^+$, 100%). FTIR (KBr/Nujol, ν , cm^{-1}) 2048, 2022 (m, $C\equiv C$). Raman (Neat sample, ν , cm^{-1}) 2024, 2047 (s, $C\equiv C$). 1H -NMR (200 MHz, C_6D_6 , δ , ppm) 7.81 (m, 4H, $H_{ortho/Ar/dppe}$); 7.40–6.90 (m, 19H, $H_{Ar/dppe} + H_{ArBr}$); 7.78 (m, 1H, H_{ArBr}); 2.52 (m, 2H, CH_{2dppe}); 1.77 (m, 2H, CH_{2dppe}); 1.58 (s, 15H, $C_5(CH_3)_5$). $^{13}C\{^1H\}$ -NMR (50 MHz, C_6D_6 , δ , ppm) 144.6 (t, $Fe-C\equiv C$, $^2J_{PC} = 39$ Hz); 140.1–123.0 (phenyls); 123.0 (s, $Br-C$); 119.6 (s, $Fe-C\equiv C$, $^3J_{PC} = ca. 4$ Hz); 88.3 (s, $C_5(CH_3)_5$); 31.1 (m, CH_{2dppe}); 10.7 (s, $^1J_{CH} = 126$ Hz, $C_5(CH_3)_5$).

5.5. Coupling of $(\eta^2-dppe)(\eta^5-C_5Me_5)Fe-C\equiv C-1,3-(C_6H_4)Br$ with phenylacetylene (**m-6a**)

The coupling was attempted as usual (see above), from 0.210 g of complex **m-2b** (0.33 mmol), 0.020 g of bis(triphenylphosphine)dichloropalladium complex (0.03 mmol), 0.010 g of copper iodide (0.06 mmol) and 0.3 ml of phenylacetylene (3.30 mmol) in 10 ml of di-*iso*-propylamine. The reaction mixture is refluxed for 15 h, the solvent is then removed in vacuum and the brown residue is extracted with toluene (8 \times 10 ml) and filtered on a celite pad. Evaporation of the toluene and washings with small portions of *n*-pentane and methanol (2–5 ml) at -40 °C yield the desired $(\eta^2-dppe)(\eta^5-C_5Me_5)Fe-C\equiv C-1,3-(C_6H_4)-C\equiv C-Ph$ complex (**m-6a**; 67%), as a

brown solid, admixed with starting complex (**m-2a**; 27%) and traces of an unidentified side product (ca. 5%). MS (positive-LSI, 3-NBA, m/z) 790 ($[(dppe)(C_5Me_5)Fe-C\equiv C(C_6H_4)C\equiv C-Ph]^+$, 100%); 655 ($[(dppe)Fe-C\equiv C(C_6H_4)C\equiv C-Ph]^+$, 10%); 589 ($[(dppe)(C_5Me_5)Fe]^+$, 55%). FTIR (KBr/Nujol, ν , cm^{-1}) 2135 (vw, $C\equiv C$); 2045 (vs, $C\equiv C$). 1H -NMR (200 MHz, C_6D_6 , δ , ppm); 8.03–6.90 (m, 29H, $m-C_6H_4 + C_6H_5 + 4C_6H_5_{dppe}$); 2.61 (m, 2H, CH_{2dppe}); 1.80 (m, 2H, CH_{2dppe}); 1.52 (s, 15H, $C_5(CH_3)_5$).

5.6. Synthesis of $(\eta^2-dppe)(\eta^5-C_5Me_5)Fe-C\equiv C-1,4-(C_6H_4)-C\equiv C-Si(^iPr)_3$ (**6b**)

Starting from 0.500 g of $(\eta^2-dppe)(\eta^5-C_5Me_5)Fe-C\equiv C-1,4-(C_6H_4)Br$ (**2b**; 0.650 mmol), 0.046 g of $(PPh_3)_2PdCl_2$ (0.065 mmol, 10%), 0.025 g of CuI (0.13 mmol, 20%), in 35 ml of di-*iso*-propylamine are introduced and 0.73 ml of tris(*iso*-propyl)silylacetylene is syringed (3.25 mmol) under argon. The reaction mixture is refluxed for 40 h and the amine is removed in vacuum. The dark residue is then extracted with toluene and filtered on a celite pad. Evaporation of toluene followed by repeated washings with cooled acetonitrile (-30 °C, 2 \times 3 ml) and *n*-pentane (2 \times 3 ml) yield the desired $(\eta^2-dppe)(\eta^5-C_5Me_5)Fe-C\equiv C-1,4-(C_6H_4)-C\equiv C-Si(^iPr)_3$ complex (**6b**) as dark orange powder (0.479 g, 0.55 mmol, 85%). MS (positive LSI, 3-NBA, m/z) 871 ($[(dppe)(C_5Me_5)Fe-C\equiv C-1,4-(C_6H_4)-C\equiv C-Si(^iPr)_3+1]$, 20%); 589 ($[(dppe)(C_5Me_5)Fe]$, 100%). FTIR (KBr/Nujol, ν , cm^{-1}) 2145 (m, $C\equiv C-Si$), 2044 (s, $Fe-C\equiv C$). 1H -NMR (200 MHz, C_6D_6 , δ , ppm) 7.91 (m, 4H, $H_{ortho/Ar/dppe}$); 7.45–6.98 (m, 20H, H_{Ar}); 2.54 (m, 2H, CH_{2dppe}); 1.78 (m, 2H, CH_{2dppe}); 1.48 (s, 15H, $C_5(CH_3)_5$); 1.21–1.02 (m, 21H, $Si[CH(CH_3)_2]_3$). $^{13}C\{^1H\}$ -NMR (50 MHz, C_6D_6 , δ , ppm) 146.1 (t, $Fe-C\equiv C$, $^2J_{PC} = 39$ Hz); 140.5–128.0 (phenyls); 122.0 (s, $Fe-C\equiv C$); 118.0 (s, $^2J_{CH} = 10$ Hz, $C-C\equiv C$); 110.5 (s, $Si-C\equiv C$); 91.8 (s, $Si-C\equiv C$); 88.6 (s, $C_5(CH_3)_5$); 31.5 (m, CH_{2dppe}); 19.5 (s, $^1J_{CH} = 126$ Hz, $Si[CH(CH_3)_2]_3$); 12.3 (s, $^1J_{CH} = 124$ Hz, $Si[CH(CH_3)_2]_3$); 11.0 (s, $^1J_{CH} = 126$ Hz, $C_5(CH_3)_5$).

5.7. Synthesis of $(\eta^2-dppe)(\eta^5-C_5Me_5)Fe-C\equiv C-1,4-(C_6H_4)-C\equiv C-SiMe_3$ (**6c**)

In a Schlenk tube, 0.500 g of $(\eta^2-dppe)(\eta^5-C_5Me_5)Fe-C\equiv C-1,4-(C_6H_4)Br$ (**2b**; 0.650 mmol), 0.046 g of $(PPh_3)_2PdCl_2$ (0.065 mmol, 10%), 0.025 g of CuI (0.13 mmol, 20%) in 35 ml of di-*iso*-propylamine are introduced and 0.46 ml of trimethylsilyl acetylene is syringed (3.25 mmol) under argon. The reaction mixture is refluxed for 64 h in a sealed vessel and the amine is removed in vacuum. The dark residue is then extracted with toluene and filtered on a celite pad. Evaporation of toluene followed by repeated washings with cooled

acetonitrile ($-30\text{ }^{\circ}\text{C}$, $2 \times 3\text{ ml}$) and *n*-pentane ($2 \times 3\text{ ml}$) yield the desired $(\eta^2\text{-dppe})(\eta^5\text{-C}_5\text{Me}_5)\text{Fe-C}\equiv\text{C-1,4-(C}_6\text{H}_4\text{)-C}\equiv\text{C-SiMe}_3$ complex (**6c**) as a pale brown powder after drying in vacuo (0.435 g, 0.55 mmol, 85%). MS (positive LSI, 3-NBA, *m/z*) 786 ($[(\text{dppe})(\text{C}_5\text{Me}_5)\text{FeC}\equiv\text{C}(\text{C}_6\text{H}_4)\text{-C}\equiv\text{CSiMe}_3]^+$, 15%); 589 ($[(\text{dppe})(\text{C}_5\text{Me}_5)\text{Fe}]^+$, 100%). FT-IR (KBr/Nujol, ν , cm^{-1}) 2147 (s, $\text{C}\equiv\text{C-Si}$), 2037 (vs, $\text{Fe-C}\equiv\text{C}$). $^1\text{H-NMR}$ (200 MHz, C_6D_6 , δ , ppm) 7.91 (m, 4H, $H_{\text{ortho/Ar/dppe}}$); 7.52–6.89 (m, 20H, H_{Ar}); 2.55 (m, 2H, $\text{CH}_{2\text{dppe}}$); 1.79 (m, 2H, $\text{CH}_{2\text{dppe}}$); 1.49 (s, 15H, $\text{C}_5(\text{CH}_3)_5$); 0.25 (s, 9H, $\text{Si}(\text{CH}_3)_3$). $^{13}\text{C}\{^1\text{H}\}\text{-NMR}$ (50 MHz, C_6D_6 , δ , ppm) 146.5 (t, $\text{Fe-C}\equiv\text{C}$, $^2J_{\text{PC}} = 39\text{ Hz}$); 140.5–127.9 (phenyls); 122.1 (s, $\text{Fe-C}\equiv\text{C}$); 117.9 (s, $^2J_{\text{CH}} = 9\text{ Hz}$, $\text{C-C}\equiv\text{C}$); 108.4 (s, $\text{Si-C}\equiv\text{C}$); 94.2 (s, $\text{Si-C}\equiv\text{C}$); 88.7 (s, $\text{C}_5(\text{CH}_3)_5$); 31.5 (m, $\text{CH}_{2\text{dppe}}$); 11.0 (s, $^1J_{\text{CH}} = 126\text{ Hz}$, $\text{C}_5(\text{CH}_3)_5$); 0.46 (s, $\text{Si}(\text{CH}_3)_3$).

5.8. Synthesis of $(\eta^2\text{-dppe})(\eta^5\text{-C}_5\text{Me}_5)\text{Fe-C}\equiv\text{C-1,4-(C}_6\text{H}_4\text{)-C}\equiv\text{C-SiMe}_3$ (**6c**) via a metalla-Sonogashira coupling

In a Schlenk tube, 0.485 g of $(\eta^2\text{-dppe})(\eta^5\text{-C}_5\text{Me}_5)\text{Fe-C}\equiv\text{CH}$ (**1**; 0.790 mmol), 0.042 g of $(\text{PPh}_3)_2\text{PdCl}_2$ (0.059 mmol, 7.5%), 0.023 g of CuI (0.118 mmol, 15%), 0.300 g of 1-(trimethylsilylacetylene)-4-bromobenzene (1.18 mmol) and 25 ml of di-*iso*-propylamine are introduced under argon. The reaction mixture is heated at $85\text{ }^{\circ}\text{C}$ for 12 h and the amine is removed in vacuum. The dark residue is then extracted with toluene (10 ml) and filtered on a celite pad. Precipitation from the toluene with *n*-pentane (7 ml), followed by filtration and repeated washings with cold acetonitrile ($-30\text{ }^{\circ}\text{C}$, $2 \times 3\text{ ml}$), then *n*-pentane ($2 \times 5\text{ ml}$), yield the desired $(\eta^2\text{-dppe})(\eta^5\text{-C}_5\text{Me}_5)\text{Fe-C}\equiv\text{C-1,4-(C}_6\text{H}_4\text{)-C}\equiv\text{C-SiMe}_3$ complex (**6c**) admixed with 1,4- $\text{Br}(\text{C}_6\text{H}_4)\text{-C}\equiv\text{C-SiMe}_3$ (ca. 0.7 eq.), as an orange powder (0.645 g total).

5.9. Synthesis of $(\eta^2\text{-dppe})(\eta^5\text{-C}_5\text{Me}_5)\text{Fe-C}\equiv\text{C-1,4-(C}_6\text{H}_4\text{)-C}\equiv\text{CH}$ (**6d**)

In a Schlenk tube, 0.350 g of $(\eta^2\text{-dppe})(\eta^5\text{-C}_5\text{Me}_5)\text{FeC}\equiv\text{C-1,4-(C}_6\text{H}_4\text{)-C}\equiv\text{C-SiMe}_3$ (**7c**; 0.440 mmol) and 0.123 g of K_2CO_3 (0.89 mmol) are introduced in a MeOH/THF (1:1) mixture under argon. The reaction mixture is stirred for 12 h at ambient temperature and the solvents are removed. The residue is then extracted with toluene ($4 \times 30\text{ ml}$), washed with *n*-pentane ($2 \times 3\text{ ml}$) and dried in vacuo. The desired $(\eta^2\text{-dppe})(\eta^5\text{-C}_5\text{Me}_5)\text{Fe-C}\equiv\text{C-1,4-(C}_6\text{H}_4\text{)-C}\equiv\text{CH}$ complex (**6d**) is isolated as an orange-brown solid (0.220 g, 0.31 mmol, yield: 70%). MS (positive LSI, 3-NBA, *m/z*) 714 ($[(\text{dppe})(\text{C}_5\text{Me}_5)\text{FeC}\equiv\text{C}(\text{C}_6\text{H}_4)\text{C}\equiv\text{CH} + 1]^+$, 15%); 589 ($[(\text{dppe})(\text{C}_5\text{Me}_5)\text{Fe}]^+$, 100%). FT-IR (KBr/Nujol, ν , cm^{-1}) 3307 (m, $\equiv\text{C-H}$), 2097 (vw, $\text{C}\equiv\text{C-H}$),

2049 (s), 2030 (m, $\text{Fe-C}\equiv\text{C}$). $^1\text{H-NMR}$ (200 MHz, C_6D_6 , δ , ppm) 7.93 (m, 4H, $H_{\text{ortho/Ar/dppe}}$); 7.45–6.89 (m, 18H, H_{Ar}); 2.84 (s, 1H, $\text{C}\equiv\text{C-H}$); 2.58 (m, 2H, CH_2); 1.80 (m, 2H, CH_2); 1.50 (s, 15H, $\text{C}_5(\text{CH}_3)_5$). $^{13}\text{C}\{^1\text{H}\}\text{-NMR}$ (50 MHz, C_6D_6 , δ , ppm) 146.0 (t, $\text{Fe-C}\equiv\text{C}$, $^2J_{\text{PC}} = 39\text{ Hz}$); 140.5–126.3 (phenyls); 121.8 (s, $\text{Fe-C}\equiv\text{C}$); 117.0 (s, $^2J_{\text{CH}} = 9\text{ Hz}$, $\text{C-C}\equiv\text{C}$); 88.7 (s, $\text{C}_5(\text{CH}_3)_5$); 85.9 (s, $\text{C}\equiv\text{C-H}$); 78.1 (s, $^2J_{\text{CH}} = 250\text{ Hz}$, $\text{H-C}\equiv\text{C}$); 31.4 (m, $\text{CH}_{2\text{dppe}}$); 11.0 (s, $^1J_{\text{CH}} = 126\text{ Hz}$, $\text{C}_5(\text{CH}_3)_5$).

5.10. Synthesis of $(\eta^2\text{-dppe})(\eta^5\text{-C}_5\text{Me}_5)\text{Fe-C}\equiv\text{C-1,4-(C}_6\text{H}_4\text{)-SiMe}_3$ (**7a**)

In a Schlenk tube, 0.300 g of $(\eta^2\text{-dppe})(\eta^5\text{-C}_5\text{Me}_5)\text{Fe-C}\equiv\text{C-1,4-(C}_6\text{H}_4\text{Br)}$ (**2b**; 0.390 mmol) in 15 ml THF is cooled to $-80\text{ }^{\circ}\text{C}$ and 0.48 ml of butyl lithium (1.6 M commercial solution in hexanes, 0.780 mmol) is added. The reaction mixture is stirred for 2 h at this temperature, after that 0.13 ml of Me_3SiCl is syringed (0.975 mmol). The temperature is further maintained at $-80\text{ }^{\circ}\text{C}$ for 30 min and the reaction is then left stirring at ambient temperature for 1 h. The solvents are removed and the residue is extracted with toluene. After evaporation of toluene, followed by repeated washings with cooled *n*-pentane ($-30\text{ }^{\circ}\text{C}$, $2 \times 3\text{ ml}$) and vacuum drying, the desired $(\eta^2\text{-dppe})(\eta^5\text{-C}_5\text{Me}_5)\text{Fe-C}\equiv\text{C-1,4-(C}_6\text{H}_4\text{)SiMe}_3$ complex (**7a**) is isolated as an orange powder (0.241 g, 0.316 mmol, 81%). MS (positive LSI, 3-NBA, *m/z*) 762 ($[(\text{dppe})(\text{C}_5\text{Me}_5)\text{FeC}\equiv\text{C}(\text{C}_6\text{H}_4)\text{SiMe}_3]^+$, 80%); 589 ($[(\text{dppe})(\text{C}_5\text{Me}_5)\text{Fe}]^+$, 100%). FT-IR (KBr/Nujol, ν , cm^{-1}) 2058 (vs, $\text{Fe-C}\equiv\text{C}$). $^1\text{H-NMR}$ (200 MHz, C_6D_6 , δ , ppm) 8.04 (m, 4H, $H_{\text{ortho/Ar/dppe}}$); 7.53–6.99 (m, 20H, H_{Ar}); 2.69 (m, 2H, $\text{CH}_{2\text{dppe}}$); 1.85 (m, 2H, $\text{CH}_{2\text{dppe}}$); 1.55 (s, 15H, $\text{C}_5(\text{CH}_3)_5$); 0.25 (s, 9H, $\text{Si}(\text{CH}_3)_3$). $^{13}\text{C}\{^1\text{H}\}\text{-NMR}$ (50 MHz, C_6D_6 , δ , ppm) 140.5–125.5 ($\text{Fe-C}\equiv\text{C}$ and phenyls); 121.5 (s, $\text{Fe-C}\equiv\text{C}$); 88.5 (s, $\text{C}_5(\text{CH}_3)_5$); 31.5 (m, $\text{CH}_{2\text{dppe}}$); 11.0 (s, $^1J_{\text{CH}} = 126\text{ Hz}$, $\text{C}_5(\text{CH}_3)_5$); -0.2 (s, $^1J_{\text{CH}} = 118\text{ Hz}$, $\text{Si}(\text{CH}_3)_3$).

5.11. Synthesis of $(\eta^2\text{-dppe})(\eta^5\text{-C}_5\text{Me}_5)\text{Fe-C}\equiv\text{C-1,4-(C}_6\text{H}_4\text{)-SnMe}_3$ (**7b**)

In a Schlenk tube, 0.350 g of $(\eta^2\text{-dppe})(\eta^5\text{-C}_5\text{Me}_5)\text{Fe-C}\equiv\text{C-1,4-(C}_6\text{H}_4\text{Br)}$ (**2b**; 0.455 mmol) in 15 ml THF is cooled to $-80\text{ }^{\circ}\text{C}$ and 0.57 ml of butyl lithium (1.6 M commercial solution in hexanes, 0.910 mmol) is added. The reaction mixture is stirred for 2 h at this temperature, after that 0.227 g of Me_3SnCl is added (1.137 mmol). The temperature is further maintained for 30 min at $-80\text{ }^{\circ}\text{C}$ and the reaction is then left stirring at ambient temperature for 1 h. The solvents are removed and the residue is extracted with toluene. After evaporation of toluene followed by one washing with cooled *n*-

pentane ($-30\text{ }^{\circ}\text{C}$, = 3 ml) and drying in vacuo, the desired $(\eta^2\text{-dppe})(\eta^5\text{-C}_5\text{Me}_5)\text{Fe-C}\equiv\text{C-1,4-(C}_6\text{H}_4\text{)-SnMe}_3$ complex (**7b**) is isolated as a brown powder (0.303 g, 0.355 mmol, 78%). MS (positive LSI, 3-NBA, m/z) 854 $([(\text{dppe})(\text{C}_5\text{Me}_5)\text{Fe-C}\equiv\text{C(C}_6\text{H}_4\text{)SnMe}_3]^+$, 8%); 589 $([(\text{dppe})(\text{C}_5\text{Me}_5)\text{Fe}]^+$, 100%). FT-IR (KBr/Nujol, ν , cm^{-1}) 2057 (s, $\text{Fe-C}\equiv\text{C}$). $^{119}\text{Sn-NMR}$ (112 MHz, C_6D_6 , δ , ppm) -30.14 (s, $\text{Sn(CH}_3\text{)}_3$). $^1\text{H-NMR}$ (200 MHz, C_6D_6 , δ , ppm) 8.04 (m, 4H, $H_{\text{ortho/Ar/dppe}}$); 7.76–6.99 (m, 20H, H_{Ar}); 2.67 (m, 2H, $\text{CH}_{2\text{dppe}}$); 1.84 (m, 2H, $\text{CH}_{2\text{dppe}}$); 1.55 (s, 15H, $\text{C}_5(\text{CH}_3)_5$); 0.30 (s, 9H, $\text{Sn(CH}_3\text{)}_3$). $^{13}\text{C}\{^1\text{H}\}\text{-NMR}$ (50 MHz, C_6D_6 , δ , ppm) 139.4 (t, $\text{Fe-C}\equiv\text{C}$, $^2J_{\text{PC}} = 36$ Hz); 140.8–128.2 (phenyls); 121.4 (s, $\text{Fe-C}\equiv\text{C}$); 88.5 (s, $\text{C}_5(\text{CH}_3)_5$); 30.9 (m, $\text{CH}_{2\text{dppe}}$); 11.2 (s, $^1J_{\text{CH}} = 126$ Hz, $\text{C}_5(\text{CH}_3)_5$); -8.1 (s, $^1J_{\text{CH}} = 129$ Hz, $\text{Sn(CH}_3\text{)}_3$).

5.12. Synthesis of $(\eta^2\text{-dppe})(\eta^5\text{-C}_5\text{Me}_5)\text{Fe-C}\equiv\text{C-1,4-(C}_6\text{H}_4\text{)-SnBu}_3$ (**7c**)

Following a rigorously similar procedure to that employed in the synthesis of **7b**, from 0.350 g of $(\eta^2\text{-dppe})(\eta^5\text{-C}_5\text{Me}_5)\text{Fe-C}\equiv\text{C-1,4-(C}_6\text{H}_4\text{Br)}$ (**2b**; 0.455 mmol) and 0.31 ml of Bu_3SnCl (1.137 mmol), the desired $(\eta^2\text{-dppe})(\eta^5\text{-C}_5\text{Me}_5)\text{Fe-C}\equiv\text{C-1,4-(C}_6\text{H}_4\text{)-SnBu}_3$ complex (**7c**) is precipitated by the addition of an equivalent volume of *n*-pentane, separated by decantation and washed further by *n*-pentane, before being dried in vacuo. The product is isolated as a viscous gum. MS (positive LSI, 3-NBA, m/z) 980 $([(\text{dppe})(\text{C}_5\text{Me}_5)\text{Fe-C}\equiv\text{C(C}_6\text{H}_4\text{)SnBu}_3]^+$, 35%); 589 $([(\text{dppe})(\text{C}_5\text{Me}_5)\text{Fe}]^+$, 100%). FT-IR (KBr/Nujol, ν , cm^{-1}) 2061 (vs, $\text{Fe-C}\equiv\text{C}$). $^1\text{H-NMR}$ (200 MHz, C_6D_6 , δ , ppm) 8.03 (m, 4H, $H_{\text{ortho/Ar/dppe}}$); 7.52–6.05 (m, 20H, H_{Ar}); 2.67 (m, 2H, $\text{CH}_{2\text{dppe}}$); 1.82 (m, 2H, $\text{CH}_{2\text{dppe}}$); 1.54 (s, 15H, $\text{C}_5(\text{CH}_3)_5$); 0.57, 1.34, 1.10 (m, $3 \times 6\text{H}$, $\text{Sn(CH}_2\text{CH}_2\text{CH}_2\text{CH}_3)_3$), 0.95 (t, 9H, $\text{Sn(CH}_2\text{CH}_2\text{CH}_2\text{CH}_3)_3$).

5.13. Synthesis of $(\eta^2\text{-dppe})(\eta^5\text{-C}_5\text{Me}_5)\text{Fe-C}\equiv\text{C-1,4-(C}_6\text{H}_4\text{)-SnPh}_3$ (**7d**)

Following a rigorously similar procedure to that employed in the synthesis of **7b**, from 0.350 g of $(\eta^2\text{-dppe})(\eta^5\text{-C}_5\text{Me}_5)\text{Fe-C}\equiv\text{C-1,4-(C}_6\text{H}_4\text{Br)}$ (**2b**; 0.455 mmol) and 0.438 g of Ph_3SnCl (1.137 mmol), the desired $(\eta^2\text{-dppe})(\eta^5\text{-C}_5\text{Me}_5)\text{Fe-C}\equiv\text{C-1,4-(C}_6\text{H}_4\text{)SnPh}_3$ complex (**7d**) is precipitated by the addition of one equivalent volume of *n*-pentane, separated by decantation and washed further *n*-pentane, before being dried in vacuo. Likewise to **7c**, it is also isolated as a viscous gum. MS (positive LSI, 3-NBA, m/z) 1040 $([(\text{dppe})(\text{C}_5\text{Me}_5)\text{Fe-C}\equiv\text{C(C}_6\text{H}_4\text{)SnPh}_3]^+$, 15%); 589 $([(\text{dppe})(\text{C}_5\text{Me}_5)\text{Fe}]^+$, 100%). FT-IR (KBr/Nujol, ν , cm^{-1}) 2058 (vs, $\text{Fe-C}\equiv\text{C}$). $^{119}\text{Sn-NMR}$ (112 MHz, C_6D_6 , δ , ppm) -81.6 (s, SnPh_3). $^1\text{H-NMR}$ (200 MHz, C_6D_6 , δ , ppm) 8.02 (m,

4H, $H_{\text{ortho/Ar/dppe}}$); 7.72–7.05 (m, 35H, H_{Ar}); 2.67 (m, 2H, $\text{CH}_{2\text{dppe}}$); 1.84 (m, 2H, $\text{CH}_{2\text{dppe}}$); 1.54 (s, 15H, $\text{C}_5(\text{CH}_3)_5$). $^{13}\text{C}\{^1\text{H}\}\text{-NMR}$ (50 MHz, C_6D_6 , δ , ppm) 141.6 (t, $\text{Fe-C}\equiv\text{C}$, $^2J_{\text{PC}} = 39$ Hz); 141.2–127.7 (phenyls); 125.8 (s, $\text{C-Sn(CH}_3\text{)}_3$); 120.6 (s, $\text{Fe-C}\equiv\text{C}$); 88.1 (s, $\text{C}_5(\text{CH}_3)_5$); 29.3 (m, $\text{CH}_{2\text{dppe}}$); 10.7 (s, $^1J_{\text{CH}} = 126$ Hz, $\text{C}_5(\text{CH}_3)_5$).

5.14. Crystal structure determination for $(\eta^2\text{-dppe})(\eta^5\text{-C}_5\text{Me}_5)\text{Fe-C}\equiv\text{C-1,4-(C}_6\text{H}_4\text{F)}$ (**2a**)

Complex **2a** was crystallised by slow diffusion of *n*-pentane in a toluene solution of the compound. The sample ($0.32 \times 0.25 \times 0.25\text{ mm}^3$) was studied on a NONIUS CAD4 with graphite monochromatised MoK_α radiation [82]. Formula: $\text{C}_{44}\text{H}_{43}\text{F}_1\text{P}_2\text{Fe}_1$, Mr = 708.57, triclinic, $P1$, $a = 12.127(4)\text{ \AA}$, $b = 12.277(3)\text{ \AA}$, $c = 15.469(2)\text{ \AA}$, $\alpha = 73.14(2)^\circ$, $\beta = 71.50(2)^\circ$, $\gamma = 60.37(3)^\circ$, $V = 1873.5(8)\text{ \AA}^{-3}$, $z = 2$, $D_x = 1.256\text{ mg m}^{-3}$, $\lambda(\text{MoK}_\alpha) = 0.71073\text{ \AA}$, $\mu = 5.22\text{ cm}^{-1}$, $F(000) = 744$, $T = 293\text{ K}$. The cell parameters are obtained by fitting a set of 25 high-theta reflections. The data collection [83] ($2\theta_{\text{max}} = 54^\circ$, scan $\omega/2\theta = 1$, $t_{\text{max}} = 60\text{ s}$ and $h\ k\ l$ range— h : 0,15; k : $-15,15$; l : $-19,19$) gives 8930 reflections, from which 6191 were retained ($I > 2.0\sigma(I)$). After Lorentz and polarisation corrections [84], the structure was solved with SIR-97 which reveals the non-hydrogen atoms of structure [85]. Anisotropic refinement allows for finding the remaining atoms by a Fourier difference map. The whole structure was refined with SHELXL97 [86] by the full-matrix least-square techniques (use of F -square magnitude; x , y , z , β_{ij} for Fe, P, C and O atoms, x , y , z in riding mode for H atoms with 434 variables and 6191 observations; calc.: $w = 1/[\sigma^2(\text{Fo}^2) + (0.077\text{P})^2]$ where $\text{P} = (\text{Fo}^2 + 2\text{Fc}^2)/3$ with the resulting $R = 0.040$, $R_w = 0.119$ and $S_w = 1.088$ (residual $\Delta\rho = 0.39\text{ e\AA}^{-3}$). Atomic scattering factors were taken from the literature [87]. ORTEP views of **2a** were realised with PLATON98 and ORTEP-3 [88,89]. All the calculations were performed on a Pentium NT Server computer.

5.15. $^{19}\text{F-NMR}$ derivation of Hammett parameters for “ $(\eta^2\text{-dppe})(\eta^5\text{-C}_5\text{Me}_5)\text{Fe-C}\equiv\text{C-}$ ”

Pure samples of the compounds **2a** and **m-2a** (0.05 mmol) were solubilised each in 1 ml freshly distilled and degassed CCl_4 . These solutions were then transferred in NMR tubes under argon and $5\text{ }\mu\text{l}$ (0.076 mmol) of fluorobenzene was syringed in the tube, as internal reference. After homogenisation of the solution, the $\{^1\text{H}\}^{19}\text{F-NMR}$ spectra were recorded at $25\text{ }^{\circ}\text{C}$. The values of σ_{I} and σ_{R} were derived from the values of the various $^{19}\text{F-NMR}$ shift differences, using the correlation established by Taft et al. [41,42] for *meta*- and *para*-fluorobenzene derivatives. From these values, σ_{p} and σ_{m}

were next computed considering the following equations:

$$\sigma_p = \sigma_I + \sigma_R, \quad (1)$$

$$\sigma_m = \sigma_I + \frac{1}{2}\sigma_R. \quad (2)$$

6. Supplementary material

Crystallographic data for $(\eta^2\text{-dppe})(\eta^5\text{-C}_5\text{Me}_5)\text{Fe}-\text{C}\equiv\text{C}-1,4\text{-(C}_6\text{H}_4\text{)-F}$ has been deposited to the Cambridge Crystallographic Data centre, as CCDC-197242. Copies of this information may be obtained free of charge from The Director, CCDC, 12 Union Road, Cambridge CB2 1EZ, UK (fax: +44-1223-336033; e-mail: deposit@ccdc.cam.ac.uk or WWW <http://www.ccdc.cam.ac.uk>).

Acknowledgements

We acknowledge S. Le Stang for preliminary experimental work and P. Jehan (CRMPO) for LSI-MS measurements.

References

- [1] F. Paul, C. Lapinte, in: M. Gielen, R. Willem, B. Wrackmeyer (Eds.), *Unusual Structures and Physical Properties in Organometallic Chemistry*, Wiley, San-Francisco, CA, 2002, p. 219.
- [2] F. Paul, C. Lapinte, *Coord. Chem. Rev.* 178/180 (1998) 427.
- [3] T. Weyland, K. Costuas, L. Toupet, J.-F. Halet, C. Lapinte, *Organometallics* 19 (2000) 4228.
- [4] T. Weyland, I. Ledoux, S. Brasselet, J. Zyss, C. Lapinte, *Organometallics* 19 (2000) 5235.
- [5] S. Le Stang, D. Lenz, F. Paul, C. Lapinte, *J. Organomet. Chem.* 572 (1998) 189.
- [6] S. Le Stang, F. Paul, C. Lapinte, *Organometallics* 19 (2000) 1035.
- [7] T. Weyland, K. Costuas, A. Mari, J.-F. Halet, C. Lapinte, *Organometallics* 17 (1998) 5569.
- [8] T. Weyland, C. Lapinte, G. Frapper, M.J. Calhorda, J.-F. Halet, L. Toupet, *Organometallics* 16 (1997) 2024.
- [9] N.J. Long, A.J. Martin, F.F. de Biani, P. Zanello, *J. Chem. Soc. Dalton Trans.* (1998) 2017.
- [10] N. Chawdhury, A. Köhler, R.H. Friend, P.R. Raithby, J. Lewis, *Macromolecules* 31 (1998) 722.
- [11] M.C.C. Colbert, J. Lewis, N.J. Long, P.R. Raithby, M. Younus, A.J.P. White, D.J. Williams, N.J. Payne, L. Yellowlees, D. Beljonne, N. Chawdhury, R.H. Friend, *Organometallics* 17 (1998) 3034.
- [12] M. Younus, A. Köhler, S. Cron, N. Chawdhury, M.R.A. Al-Mandhary, M.S. Khan, J. Lewis, N.J. Long, R.H. Friend, P.R. Raithby, *Angew. Chem. Int. Ed. Engl.* 37 (1998) 3036.
- [13] W.-Y. Wong, W.-K. Wong, P.R. Raithby, *J. Chem. Soc. Dalton Trans.* (1998) 2761.
- [14] J. Lewis, P.R. Raithby, W.-Y. Wong, *J. Organomet. Chem.* 556 (1998) 219.
- [15] H. Werner, P. Bachmann, M. Laubender, O. Gevert, *Eur. J. Inorg. Chem.* (1998) 1217.
- [16] M. Uno, P.H. Dixneuf, *Angew. Chem. Int. Ed. Engl.* 37 (1998) 1714.
- [17] M.I. Bruce, B.C. Hall, P.J. Low, B.W. Skelton, A.H. White, *J. Organomet. Chem.* 592 (1999) 74.
- [18] M. Younus, N.J. Long, P.R. Raithby, J. Lewis, *J. Organomet. Chem.* 570 (1998) 55.
- [19] O. Lavastre, J. Plass, P. Bachmann, S. Guesmi, C. Moinet, P.H. Dixneuf, *Organometallics* 16 (1997) 184.
- [20] S. di Bella, *Chem. Soc. Rev.* 30 (2001) 355.
- [21] B.J. Coe, *Chem. Eur. J.* 5 (1999) 2464.
- [22] I.R. Whittall, A.M. MacDonagh, M.G. Humphrey, M. Samoc, *Adv. Organomet. Chem.* 42 (1998) 291.
- [23] C. Gauss, D. Veghini, H. Berke, *Chem. Ber.* 130 (1997) 183.
- [24] H. Werner, P. Bachmann, M. Martin, *Can. J. Chem.* 79 (2001) 519.
- [25] R.B. Bedford, C.S.J. Cazin, *J. Organomet. Chem.* 598 (2000) 20.
- [26] G. Albertin, S. Antoniutti, E. Bordignon, M. Granzotto, *J. Organomet. Chem.* 585 (1999) 83.
- [27] M.I. Bruce, B.C. Hall, B.D. Kelly, P.J. Low, B.W. Skelton, A.H. White, *J. Chem. Soc. Dalton Trans.* (1999) 3719.
- [28] P. Siemsen, R.C. Livingstone, F. Diederich, *Angew. Chem. Int. Ed. Engl.* 39 (2000) 2633.
- [29] I.B. Campbell, in: J.K. Taylor (Ed.), *Organocopper Reagent—A Practical Approach*, Oxford University Press, Oxford, 1994, p. 216.
- [30] S. Takahashi, Y. Kuroyama, S. Sonogashira, N. Hagihara, *Synthesis* (1980) 627.
- [31] K. Sonogashira, Y. Tohda, N. Hagihara, *Tetrahedron Lett.* 50 (1975) 4467.
- [32] M.I. Bruce, M. Ke, P.J. Low, B.W. Skelton, A.H. White, *Organometallics* 17 (1998) 3539.
- [33] M.I. Bruce, M. Ke, P.J. Low, *J. Chem. Soc. Chem. Commun.* (1996) 2405.
- [34] R. Denis, T. Weyland, F. Paul, C. Lapinte, *J. Organomet. Chem.* 545/546 (1997) 615.
- [35] R. Denis, L. Toupet, F. Paul, C. Lapinte, *Organometallics* 19 (2000) 4240.
- [36] J. March, *Advanced Organic Chemistry: Reactions, Mechanisms and Structures*, Wiley, New York, 1992.
- [37] S. Le Stang, F. Paul, C. Lapinte, *Chem. Heterocyc. Compounds* 387 (1999) 1207.
- [38] N.G. Connelly, M.P. Gamasa, J. Gimeno, C. Lapinte, E. Lastra, J.P. Maher, N. Le Narvor, A.L. Rieger, P.H. Rieger, *J. Chem. Soc. Dalton Trans.* (1993) 2775.
- [39] N. Le Narvor, C. Lapinte, *Organometallics* 14 (1995) 634.
- [40] F.H. Allen, O. Kennard, D.G. Watson, L. Brammer, A.G. Orpen, R. Taylor, *J. Chem. Soc. Perkin Trans. 2* (1987) S1.
- [41] R.W. Taft, E. Price, I.R. Fox, I.C. Lewis, K.K. Andersen, G.T. Davies, *J. Am. Chem. Soc.* 85 (1963) 3146.
- [42] R.W. Taft, E. Price, I.R. Fox, I.C. Lewis, K.K. Andersen, G.T. Davies, *J. Am. Chem. Soc.* 85 (1963) 709.
- [43] C. Hansch, A. Leo, R.W. Taft, *Chem. Rev.* 91 (1991) 165.
- [44] S.K. Hurst, M.P. Cifuentes, A.M. MacDonagh, M.G. Humphrey, M. Samoc, B. Luther-Davies, I. Asselberghs, A. Persoons, *J. Organomet. Chem.* 642 (2002) 259.
- [45] F. Paul, W. Meyer, H. Jiao, L. Toupet, J.A. Gladysz, C. Lapinte, *J. Am. Chem. Soc.* 122 (2000) 9405.
- [46] R. Dembinski, T. Bartik, B. Bartik, M. Jaeger, J.A. Gladysz, *J. Am. Chem. Soc.* 122 (2000) 810.
- [47] R. Eastmond, D.R.M. Walton, *Tetrahedron* 28 (1972) 5221.
- [48] R. Eastmond, T.R. Johnson, D.R.M. Walton, *Tetrahedron* 28 (1972) 4601.
- [49] R. Eastmond, D.R.M. Walton, *Tetrahedron* 28 (1972) 4591.
- [50] G. Rodriguez, M. Albrecht, J. Schoenmaker, A. Ford, M. Lutz, A.L. Spek, G. van Koten, *J. Am. Chem. Soc.* 124 (2002) 5127.

- [51] I.-Y. Wu, J.T. Lin, Y.S. Wen, *Organometallics* 18 (1999) 320.
- [52] F. Paul, J.-Y. Mevellec, C. Lapinte, *J. Chem. Soc. Dalton Trans.* (2002) 1783.
- [53] K. Costuas, F. Paul, J.-F. Halet, C. Lapinte, in preparation.
- [54] F. Paul, K. Costuas, I. Ledoux, S. Deveau, J. Zyss, J.-F. Halet, C. Lapinte, *Organometallics*, 21 (2002) 5229.
- [55] J. Evans, J.R. Norton, *Inorg. Chem.* 13 (1974) 3042.
- [56] E. Pitcher, A.D. Buckingham, F.G.A. Stone, *J. Chem. Phys.* 36 (1961) 124.
- [57] A.R. Bassindale, C. Eaborn, D.R.M. Walton, *J. Organomet. Chem.* 21 (1970) 91.
- [58] F.J. Hopton, A.J. Rest, D.T. Rosevear, F.G.A. Stone, *J. Chem. Soc. A* (1966) 132.
- [59] F. Hruska, H.M. Hutton, T. Schaefer, *Can. J. Chem.* 43 (1965) 2392.
- [60] A. Saika, C.P. Slichter, *J. Chem. Phys.* 22 (1954) 26.
- [61] R.P. Stewart, P.M. Treichel, *J. Am. Chem. Soc.* 92 (1970) 2710.
- [62] M. Sato, H. Shintate, Y. Kawata, M. Sekino, M. Katada, S. Kawata, *Organometallics* 13 (1994) 1956.
- [63] D.W. Slocum, C.R. Ernst, *Adv. Organomet. Chem.* 10 (1972) 79.
- [64] H. Yao, M. Sabat, R.N. Grimes, *Organometallics* 21 (2002) 2833.
- [65] M.-K. Lau, Q.-F. Zhang, J.L.C. Chim, W.-T. Wong, W.-H. Leung, *Chem. Commun.* (2001) 1478.
- [66] P.J. Connors, Jr., D. Tzalis, A.L. Dunnick, Y. Tor, *Inorg. Chem.* 37 (1998) 1121.
- [67] M. Pui Yin Yu, K.-K. Cheung, A. Mayr, *J. Chem. Soc. Dalton Trans.* (1998) 2373.
- [68] I. Matsuoka, K. Aramaki, H. Nishihara, *J. Chem. Soc. Dalton Trans.* (1998) 147.
- [69] T.J.J. Müller, H.J. Lindner, *Chem. Ber.* 129 (1996) 607.
- [70] T.J.J. Müller, M. Ansorge, H.J. Lindner, *Chem. Ber.* 129 (1996) 1433.
- [71] A. Harriman, R. Ziessel, *Chem. Commun.* (1996) 1707.
- [72] D. Tzalis, Y. Tor, *Chem. Commun.* (1995) 1043.
- [73] R.P. Hsung, C.E.D. Chidsey, L.R. Sita, *Organometallics* 14 (1995) 4808.
- [74] M.I. Bruce, G.A. Koutsantonis, M.J. Liddell, *J. Organomet. Chem.* 320 (1987) 217.
- [75] J.K. Stille, *Angew. Chem. Int. Ed. Engl.* 25 (1986) 508.
- [76] J.K. Stille, J.H. Simpson, *J. Am. Chem. Soc.* 109 (1987) 2138.
- [77] J.K. Stille, *Pure Appl. Chem.* 57 (1985) 1771.
- [78] M. Tilset, I. Fjeldahl, J.-R. Hamon, P. Hamon, L. Toupet, J.-Y. Saillard, K. Costuas, A. Haynes, *J. Am. Chem. Soc.* 123 (2001) 9984.
- [79] N. Le Narvor, L. Toupet, C. Lapinte, *J. Am. Chem. Soc.* 117 (1995) 7129.
- [80] C. Roger, P. Hamon, L. Toupet, H. Rabaâ, J.-Y. Saillard, J.-R. Hamon, C. Lapinte, *Organometallics* 10 (1991) 1045.
- [81] D.L. Pearson, J.M. Tour, *J. Org. Chem.* 62 (1997) 1376.
- [82] C.K. Fair, *MolEN: An Interactive Intelligent System for Crystal Structure Analysis ENRAF-NONIUS*, 1990.
- [83] B.V. Nonius, *Kappa CCD Software*, Delft, 1999.
- [84] A.L. Spek, *HELENA: program for the handling of CAD4-diffractometer output SHELX(S/L)*, Utrecht University, 1997.
- [85] A. Altomare, M.C. Burla, M. Camalli, G. Cascarano, C. Giacovazzo, A. Guagliardi, A.G.G. Moliterni, G. Polidori, R. Spagna, *J. Appl. Chem.* 31 (1998) 74.
- [86] G.M. Sheldrick, *SHELX97-2: program for the refinement of crystal structures*, University of Göttingen, 1997.
- [87] D. Reidel, *International Tables for X-ray Crystallography*, vol. IV, Kynoch Press (present distrib. D. Reidel, Dordrecht), 1974.
- [88] A.L. Spek, *PLATON: a multipurpose crystallographic tool*, Utrecht University, 1998.
- [89] L.J. Farrugia, *J. Appl. Crystallogr.* 30 (1997) 565.
- [90] N.G. Connelly, W.E. Geiger, *Chem. Rev.* 96 (1996) 877.