

Effects of Porphyrin Core Saddling, *meso*-Phenyl Twisting, and Counterions on the Optical Properties of *meso*-Tetraphenylporphyrin Diacids: The [H₄TPP](X)₂ (X = F, Cl, Br, I) Series as a Case Study

Angela Rosa,^{*,†} Giampaolo Ricciardi,^{*,†} Evert Jan Baerends,^{*,‡} Andrea Romeo,[§] and Luigi Monsù Scolaro^{*,§}

Contribution from the Dipartimento di Chimica, Università della Basilicata, Via N. Sauro 85, 85100 Potenza, Italy, Afdeling Theoretische Chemie, Vrije Universiteit, De Boelelaan 1083, 1081 HV Amsterdam, The Netherlands, Dipartimento di Chimica Inorganica, Chimica Analitica e Chimica Fisica, Università di Messina, and INFM, Messina, Italy

Received: August 20, 2003

The ground- and excited-state properties of a series of *meso*-tetraphenylporphyrin (H₂TPP) diacids, [H₄TPP](X)₂ (X = F, Cl, Br, I), ad hoc synthesized and characterized by ¹H NMR, RLS, and UV–vis spectroscopies, have been studied theoretically using density functional theory (DFT) and time-dependent density functional theory (TDDFT). Several conformations corresponding to different deformations of the porphyrin core have been explored. The nearly degenerate purely saddled (*sad*) and hybrid (saddled with a small superimposed ruffling: *sadruf*) conformations are the preferred “gas phase” conformations. The type and degree of distortion of the macrocycle and the orientation of the phenyl rings compare well to X-ray data available for H₂TPP diacids. Two electronic structure features are key to an understanding of the optical and photophysical properties. (1) Strong interaction of the π -system of the phenyls with the π -system of the porphyrin leads to an upshift of the G-a_{2u} (G = Gouterman) orbital and, hence, to a significant splitting of the occupied pair of a_{2u}/a_{1u} Gouterman orbitals. The diminished G-a_{2u}/G-e_g* gap and the lifting of the a_{2u}/a_{1u} degeneracy explain the red shift of the Q and B bands and the hyperchromicity of the Q-band in the diacids. (2) The highest occupied orbitals of the diacids comprise the set of halide lone pair orbitals, which move from completely above the Gouterman orbitals (I⁻ counterion) to below them (F⁻). The lowest halide to porphyrin charge-transfer (HPCT) transitions are therefore predicted at very low energy (to the red of the Q-band) for Cl⁻–I⁻, but with very low intensity. Weak measured absorptions to the red of the Q-band support these theoretical findings. Quenching of the S₁ (Q) state via these low-lying singlet HPCT excited states accounts for the decrease of the fluorescence quantum yield and for the measured trend along the series.

Introduction

Porphyrin diacids, a class of compounds obtained by diprotonation of free base porphyrins, have attracted considerable interest since the mid-1960s because of their intrinsically appealing structural^{1–8} and photophysical^{9–12} properties. Their capability to form *J*-aggregates under specific conditions further stimulated this interest. The ultrafast nonlinear optical properties of *J*-aggregates based on porphyrin diacids are currently investigated^{13,14} with relevance to the processes in biological pigment systems.¹⁵

Porphyrin diacids typically have nonplanar structures with mainly saddle-type distortions (*D*_{2d} symmetry) of the porphyrin core, as revealed by X-ray crystallography.^{1–8}

The deviations from planarity for diacids bearing *meso*-phenyl rings, such as H₂TPP diacids, approach in magnitude those seen in peripherally crowded porphyrins, such as free-base octaethyltetraphenylporphyrin (H₂OETPP),¹⁶ dodecaphenylporphyrin (H₂DPP),¹⁷ and octabromotetraphenylporphyrin (H₂Br₈TPP).¹⁸

Diprotonation of the porphyrin core has important effects on the static and dynamic photophysical properties of the diacids

compared to their free-base parents. Some of these effects, such as those derived from increased symmetry, are analogous to those that occur upon formation of a corresponding metal derivative. They include (i) a collapse of the four main visible-region ground-state absorption bands [Q_y(1,0), Q_y(0,0), Q_x(1,0), Q_x(0,0)] of the free base to two [Q(1,0), Q(0,0)], (ii) a blue shift of the Q(0,0) band of the diacid (like the metal complex) from the Q_x(0,0) band of the free base, namely, to a position between the Q_y(0,0) and Q_x(0,0) pair, and (iii) a blue shift of the B band of the diacid from the B band of the free base. These effects are observed for many diacids, including H₂OEP (octaethylporphyrin) diacids.¹² H₂TPP diacids are, however, somewhat peculiar in that, contrary to the above-cited general rule, their absorption spectra show a large red shift of the Q and B bands relative to H₂TPP.¹²

Additionally, relative to the parent free bases, the diacids exhibit broadened optical bands, increased spacing between absorption and emission maxima, and reduced lifetimes of the predominant (and minor) components of the S₁(π,π) fluorescence decay.^{9–12} All these effects are enhanced in H₂TPP diacids.¹²

Although the photophysical properties of porphyrin diacids have been widely investigated experimentally, they are far from having been fully rationalized. The first consistent interpretation

* To whom correspondence should be addressed.

† Università della Basilicata.

‡ Vrije Universiteit.

§ Università di Messina.

of the perturbed photophysical properties of porphyrin diacids, including H₂TPP diacids, has been provided only recently by Chirvony et al.¹² on the basis of a comparative study of the static and dynamic photophysical behavior of H₂TPP and H₂OEP diacids. Their arguments rely on the key concept that the perturbed photophysical properties of porphyrin diacids can be rationalized only by looking at them in terms of both purely electronic and (ultimately electronic) nonplanar distortion effects. According to these authors, the enhanced nonradiative decays and many other photophysical consequences of diacid formation have to be ascribed primarily to nonplanar macrocycle distortions, which allow for a number of ground- and excited-state conformations to be accessible. The more perturbed photophysical properties of H₂TPP versus H₂OEP diacids are correlated with the larger conformational degrees of freedom of the former. This is due not only to their larger distortion from planarity but also to their inherently greater flexibility induced by the presence of the phenyl rings, whose rotation and tilting may be coupled with the nonplanarity of the macrocycle. Previously, the enhancement of the S₁ → S₀ internal conversion in H₂TPP and H₂-*o*-TPP (*meso*-tetrakis(*o*-tolyl)-porphyrin) diacids relative to the corresponding parent free bases was attributed to quenching of the S₁ state via a low-lying electronic state involving charge-transfer between the porphyrin and the peripheral phenyl rings.¹¹ However, as remarked by Chirvony et al., the participation of a PhPCT (phenyl to porphyrin charge transfer) or PPhCT (porphyrin to phenyl charge transfer) excited state cannot additionally explain the perturbed static optical properties of *meso*-phenyl containing porphyrin diacids or the characteristics of H₂OEP diacid, which lacks the peripheral phenyl rings. The large red shift of the Q and B bands in H₂TPP diacids is explained by Chirvony et al., by analogy with sterically crowded nonplanar porphyrins bearing *meso*-phenyl rings, which also exhibit red-shifted bands compared to their nominally planar analogues, in terms of electronic effects of macrocycle distortion induced rotation of the phenyl rings. While indeed in the nominally planar free base the phenyl rings lie almost perpendicular to the porphyrin plane, in the highly distorted structure of the H₂TPP diacids, and of sterically crowded nonplanar porphyrins as well, they rotate toward a more parallel position, which allows for conjugation of the phenyl rings with the porphyrin macrocycle. Gouterman et al.,¹⁹ in the context of a semiempirical INDO/CI study of the origin of hyperporphyrin spectra in sequentially protonated *meso*-(dimethylaminophenyl)porphyrins, also suggest that the red shift and the enhanced intensity of the Q band in the bare H₄TPP²⁺ may be related to phenyl character in the HOMO. That the electronic effects of the macrocycle distortion induced rotation of the phenyl rings rather than the saddling by itself could be at the origin of the red shift of the Q and B bands in *meso*-aryl bearing porphyrins was also suggested by DiMugno et al.²⁰ on the basis of structural and spectroscopic data concerning strongly saddled cobalt(II) porphyrins with and without substituent groups capable of π interaction with the porphyrin core. In the last years many theoretical studies have addressed the question as to whether nonplanar distortions of the porphyrin core are responsible for the red-shifted electronic spectra of nonplanar porphyrins (for a chronological summary see ref 21 and references therein). Worth mentioning in this context are the DFT/TDDFT studies by DiMugno et al.²² and by Ghosh et al.²³ and the combined experimental and theoretical work by Marchon, Medforth, Shelnutt, et al.²⁴ Both DFT/TDDFT studies have shown that a porphyrin can be deformed into a very nonplanar structure without showing a large red shift and that

the observed red-shifted optical spectra of substituted nonplanar porphyrins must result from the in-plane nuclear reorganizations (IPNRs), as proposed by DiMugno and co-workers.²² By contrast, Marchon, Medforth, Shelnutt, et al.²⁴ provide computational evidence that the red shifts of highly ruffled *meso*-tetra-(alkyl)porphyrins result not from structural displacements along the ruffling mode but from displacements along higher frequency out-of-plane modes that have the same symmetry as the ruffling mode. None of these studies paid attention to the important class of nonplanar porphyrins bearing substituent groups capable of π interaction with the porphyrin core. Thus, whether and to what extent the red shift of the Q and B bands observed in highly saddled *meso*-arylporphyrins, including H₂TPP diacids, is brought about by electronic effects of the π -conjugation of the *meso*-phenyl rings with the porphyrin core are still open questions. It is the main purpose of this investigation to answer these questions by DFT/TDDFT theoretical methods. Using the H₂TPP diacids as a case study, we will elucidate the effects of the *meso*-phenyl twisting and of the porphyrin core distortions on the ground and excited states of H₂TPP diacids. We will focus on the ad hoc synthesized and spectroscopically characterized [H₄TPP](X)₂ (X = F, Cl, Br, I) diacid salts, because they provide an ideal series for exploring the additional effects of the size and nature of the counterions. A thorough analysis of the structural and spectroscopic properties of H₂TPP diacids cannot leave aside the counterions, indeed. It is by now well established that close interactions exist between the diprotonated porphyrins and the conjugate bases of two acid molecules, either in the solid state^{1–8} or in solutions of organic solvents.^{25–27} There is, additionally, clear evidence for the nature of the counterions influencing significantly the photophysical parameters of the porphyrin diacids.¹¹

Experimental Section

Chemicals and Preparation of the Diacid Samples. *meso*-Tetraphenylporphyrin was purchased from Aldrich and used as received. Solutions of this porphyrin were prepared in spectrophotometric grade dichloromethane (Sigma) and stirred for 1 day till complete dissolution. To avoid or minimize dust contamination during light scattering experiments, special care was taken by filtering all the stock solutions through 0.22-mm Millipore filters.

The stock solutions were stored in the dark and used within a week of preparation. The range of concentration [(5–10) × 10⁻⁶ M] used in our experiments was determined spectrophotometrically using 4.78 × 10⁵ M⁻¹ cm⁻¹ at the Soret maximum ($\lambda = 418$ nm).¹⁰

All the hydrogen halides were of the highest commercial grade available and were used as received without further purification. H₂TPP diacid solutions were prepared by injecting acid vapors to a prefixed volume of porphyrin stock solution. This injection was performed by using a homemade glass kit connected directly to a reservoir of concentrated acid solution and the complete conversion of the porphyrin into the diacid form was directly monitored through UV/vis spectroscopy.

Spectroscopic Methods. UV/vis absorption spectra were measured on a Hewlett-Packard model HP 8453 diode array spectrophotometer. To avoid the photogeneration of HCl by UV decomposition of the chlorinated solvent,²⁸ all the spectra have been measured using a UV-34 filter. Fluorescence emission and resonance light-scattering (RLS) experiments were performed on a Jasco model FP-750 spectrofluorimeter equipped with a Hamamatsu R928 photomultiplier. For RLS experiments a synchronous scan protocol with a right angle geometry was used.

Fluorescence and RLS spectra were not corrected for absorption of the samples.

Fluorescence quantum yields of diacid derivatives were determined by using H₂TPP in benzene as standard ($\Phi = 0.13$) and corrected for absorbance of the sample.¹⁰

To resolve overlapping bands, background subtraction and deconvolution of experimental spectra were carried out with PEAKFIT (Jandel Scientific, San Rafael, CA) software for nonlinear curve fitting analysis. After fixing some arbitrary positions of the component bands in the spectra, these wavelengths were used as initial parameters for curve fitting with Gaussian component peaks. Position, bandwidths, and amplitudes of the peaks were varied until (i) the resulting bands shifted by no more than 2 nm from the initial parameters, (ii) good agreement between the calculated sum of all components, and the experimental spectra was achieved ($r^2 > 0.99$).

Even when deconvoluted spectra would be available, the spectral band integration for estimating the oscillator strengths from

$$f = (3.32 \times 10^{-9}) \int \epsilon(\nu) d\nu \quad (1)$$

does not always provide unambiguous results. For this reason a single Gaussian function was used to represent the experimental spectral bands which gives rise to an approximate measure of the corresponding band intensity,

$$f = (3.32 \times 10^{-9}) \int e^{-(\Delta\nu/\theta)^2} d\nu = (3.32 \times 10^{-9}) \sqrt{\pi} \epsilon_{\max} \theta \quad (2)$$

where θ is the half-width at $\epsilon = \epsilon_{\max}/e$. The θ width parameter relates to the full-width (h) at half-maximum ($\epsilon_{\max}/2$) by $h = 2(\ln 2)^{1/2}\theta$.

The oscillator strengths obtained from eq 2 neglect the solvent refractive index correction. For common solvents, the inclusion of the refractive index correction may result in changes on the order of 10–20%.²⁹

¹H NMR spectra were obtained on a Bruker AMX-R 300 spectrometer equipped with a broadband probe operating at 300.13 MHz. Sample solutions in CDCl₃ were referenced to the internal residual solvent peak. Chemical shifts (δ) are reported in ppm downfield from TMS.

Formation of H₂TPP *J*-aggregates adsorbed at the toluene–water (sulfuric acid aqueous solution) interface has been recently reported.³⁰

To rule out the occurrence of aggregation upon protonation, we performed a series of resonance light scattering experiments of the various derivatives. The RLS effect arises from an enhancement of the scattered light intensity in close proximity of an absorption band of an aggregating chromophore. Consequently, RLS technique is a very sensitive and selective tool for detecting aggregation phenomena, even in complex systems. The occurrence of this phenomenon is related to a strong electronic coupling between adjacent chromophores, to the size and the geometry of the resulting aggregate, and to intense molar absorbance of the monomeric constituents.³¹

The intensity of the RLS spectra of H₂TPP is rather low and almost comparable to that of the neat solvent. The profile exhibits a deep well at 419 nm, due to photon absorption at this wavelength. Upon acidification, the wells move to larger wavelength, according to the general red shift observed in the corresponding UV/vis spectra, the intensities being almost unaltered (see the supporting information). All these experimental findings point to the absence of extended aggregation phenomena³² in this organic solvent.

Theoretical Methods. All calculations reported in this paper have been performed with the ADF (Amsterdam Density Functional) suite of programs, release 2002.03.^{33–35}

The theoretical method used is based on the time-dependent extension of the density functional theory.^{36–38} The time-dependent density functional theory (TDDFT) is thoroughly reviewed in refs 36, 37, 39, and 40. In the ADF implementation^{38,41} the solution of the TDDFT response equations proceeds in an iterative fashion starting from the usual ground-state or zero-order Kohn–Sham (KS) equations.⁴¹ For these one needs an approximation to the usual static exchange–correlation (xc) potential $v_{xc}(r)$. After the ordinary KS equations have been solved, the first-order density change has to be calculated from an iterative solution to the first-order KS equations. In these first-order equations an approximation is needed to the first functional derivative of the time-dependent xc potential $v_{xc}(\mathbf{r}, t)$ with respect to the time-dependent density $\rho(\mathbf{r}', t')$, the so-called xc kernel. For the xc kernel we use the adiabatic local density approximation (ALDA). In this approximation the time dependence (or frequency dependence if one talks about the Fourier transformed kernel) is neglected, and one simply uses the differentiated static LDA expression. In our case we use the Vosko–Wilk–Nusair parametrization.⁴² For the exchange–correlation potentials which appear in the zero-order KS equations, we have used the generalized gradient approximated (GGA) potential v_{xc}^{BP} , employing Becke's⁴³ gradient approximation for exchange and Perdew's⁴⁴ for correlation. For [H₄TPP](Br)₂ and [H₄TPP](I)₂ we make use of a combined scalar relativistic (SR) ZORA (zero-order regular approximation)^{45–49} and DFT/TDDFT approach. The (SR) ZORA/TDDFT approach implies that the one-electron energies and the Kohn–Sham orbitals to be used in the TDDFT response equations are obtained by solving the one-electron (SR) ZORA Kohn–Sham equations.^{47,48} The (SR) ZORA geometries of [H₄TPP](Br)₂ and [H₄TPP](I)₂ were obtained by using the recent implementation of analytical gradients for ZORA in ADF.⁴⁹ In the geometry optimizations the usual (nonrelativistic) BP density functional was used. For the nonrelativistic calculations we use the all-electron ADF TZ2P basis set⁵⁰ which is an uncontracted triple- ζ STO basis set with one 3d and one 4f polarization function for C, N, F, and Cl atoms, one 2p, and one 3d polarization function for H.

For the (SR) ZORA calculations on [H₄TPP](Br)₂ and [H₄TPP](I)₂ we use an optimized valence basis set which is of the same size as the standard all-electron ADF TZ2P basis set, i.e., an uncontracted triple- ζ STO basis with two polarization functions (H: 2p, 3d. C, N: 3d, 4f. Br: 4d, 4f. I: 5d, 4f).

The hydrogen bonds between the porphyrin dication and the two halides are analyzed in the conceptual framework provided by the Kohn–Sham molecular orbital (KS-MO) model⁵¹ using a Morokuma-type scheme to decompose the bond energy.^{52,53} The interaction energy between the porphyrin dication and the two halides, ΔE_{int} , is split up into three physically meaningful terms

$$\Delta E_{\text{int}} = \Delta V_{\text{elstat}} + \Delta E_{\text{Pauli}} + \Delta E_{\text{oi}} \quad (3)$$

The term ΔV_{elstat} corresponds to the classical electrostatic interaction between the unperturbed charge distributions of the interacting molecular fragments and is usually attractive. The Pauli-repulsion term, ΔE_{Pauli} , comprises the destabilizing interactions between occupied orbitals and is responsible for the steric repulsion. The orbital interaction, ΔE_{oi} , accounts for charge transfer (interaction between occupied orbitals on one molecular fragment and unoccupied orbitals on the other), and

polarization (empty/occupied orbital mixing on one fragment), although these terms are, unlike in Morokuma's original scheme, not explicitly distinguished. The ΔE_{oi} term can be decomposed, using the extended transition state (ETS) method developed by Ziegler and Rauk,⁵⁴ into the contributions from each irreducible representation Γ of the overall symmetry group of the system:

$$\Delta E_{oi} = \sum_{\Gamma} \Delta E(\Gamma) \quad (4)$$

Results and Discussion

Synthesis and Characterization of Diacid Salts. The $[\text{H}_4\text{TPP}](\text{X})_2$ ($\text{X} = \text{F}, \text{Cl}, \text{Br}, \text{I}$) diacid derivatives were easily prepared by reacting a solution of the free base H_2TPP in dichloromethane with vapors of the proper hydrogen halide. The progress of the reaction was followed in situ by monitoring the UV/vis spectral changes occurring upon protonation. In particular, the Soret band of H_2TPP at 419 nm is gradually converted into a red-shifted band, while the four Q bands decrease in number and move to lower energies.

The ^1H NMR resonances of $[\text{H}_4\text{TPP}](\text{X})_2$ and the parent H_2TPP in CDCl_3 are collected in Table S1 and are in agreement with previous literature data.²⁷ Upon protonation, with respect to the free base, the pyrrole β -proton resonance at δ 8.83 moves to lower frequency ($\Delta\delta = -0.27 \pm 0.02$ ppm), while those of the phenyl protons shift to higher frequencies ($\Delta\delta = 0.4 \pm 0.02$ ppm for the ortho protons, and $\Delta\delta = 0.24 \pm 0.01$ ppm for the meta and para protons, respectively). The resonance due to the protonated core nitrogen atoms appears as a broad singlet. At difference with the other resonances, which are scarcely influenced by the nature of the counterion, the NH groups undergo larger chemical shift changes and their position is strongly dependent on the halide. The observed deshielding effect increases on increasing the electronegativity χ of the halide ($\delta = -(5.41 \pm 0.33) + (1.78 \pm 0.10)\chi$, $R^2 = 0.996$)⁵⁵ and decreasing the size of the corresponding anion ($\delta = (5.60 \pm 0.43) - (2.93 \pm 0.23)\chi$, $R^2 = 0.994$).⁵⁶ This suggests that small anions, such as F^- and Cl^- , bind strongly to the porphyrin dication, whereas large anions, such as Br^- and I^- , form weaker tight-contact pairs.

Molecular Structure. The most remarkable feature of the molecular structure of H_2TPP diacids is the distortion from planarity. The available X-ray data^{1,4,8} indicate that these molecules possess a saddled porphyrin core with the pyrrole rings tilted alternately up and down, almost as rigid bodies. The angle of tilt of the pyrrole rings from the 24-atom mean plane, ϕ , ranges between 28 and 33°, the average absolute perpendicular displacement of the pyrrole β -carbon atoms from the 24-atom mean plane, $|\Delta C_{\beta}|$, which provides an alternative measure of the deviation from planarity, ranging between 0.9 and 1.07 Å. Structural data also reveal a small to negligible sideways tilt (ruffling) of the pyrrole rings superimposed on the large vertical tilt. The molecular parameters which define the degree of ruffling, i.e., the transannular dihedral angle, $(C_{\alpha}\text{N}C_{\alpha})_{\text{op}}$, and the out-of-plane displacement of the meso-carbon atoms from the 24-atom mean plane, $|\Delta C_{\beta}|$, range indeed between 2.7 and 15° and 0.02–0.28 Å, respectively.

Another relevant structural peculiarity of H_2TPP diacids is the twisting of the *meso*-phenyl groups, the porphyrin-phenyl dihedral angles, θ , ranging between 21 and 33°.

In the absence of structural data for the investigated series of H_2TPP diacids, we have carried out a detailed theoretical investigation of their molecular structures. As point of reference for the diacids, the molecular structure of H_2TPP , which

crystallizes in both a near-planar triclinic structure and S_4 -ruffled tetragonal conformation,^{57–61} was also examined.

For the bare $\text{H}_4\text{TPP}^{2+}$ and $[\text{H}_4\text{TPP}](\text{X})_2$ ($\text{X} = \text{F}, \text{Cl}, \text{Br}, \text{I}$) diacids five types of core conformations have been theoretically explored: (i) D_{2d} -saddled conformations (*sad*); (ii) C_2 -hybrid conformations (*sadruf*) characterized by a combination of saddled and ruffled nonplanar deformations; (iii) C_{2h} -stepped conformations (*steпа*) with an adjacent pair of pyrrole NH groups tipped above the porphyrin mean plane and the other pair of NH groups canted below the porphyrin mean plane (a *steпа*-type conformation was observed in the solid-state structure of an alkyl-substituted porphyrin diacid derivative, $[\text{H}_4\text{TCHP}](\text{TFA})_2$ (H_2TCHP = tetracyclohexa[*b,g,l*]porphyrin; TFA = trifluoroacetate);⁶ (iv) C_{2h} -stepped conformations (*stepo*) with one pair of trans pyrrole rings lying in the porphyrin mean plane and the NH groups of the second pair of pyrrole rings tipped above and below the porphyrin mean plane (for the bare dication such a conformation was predicted by molecular mechanics (MM) calculations⁸ to be more stable than the *steпа*); (v) D_{4h} -planar conformations (planar) with the four phenyl rings orthogonal to the porphyrin plane. A schematic representation of the energy-minimized *sad*, *sadruf*, *steпа*, and *stepo* conformers is given in Figure 1, for the representative case of $[\text{H}_4\text{TPP}](\text{I})_2$. In our choice of the axes, the z axis is perpendicular to the plane of the meso-carbon atoms. This implies that in the *steпа* and *stepo* structures the C_2 axis is not the z axis, but the y -axis passing between an up and a down pyrrole in the case of *steпа* and bisecting the two opposite coplanar pyrroles in the case of *stepo*. As for H_2TPP , we have explored theoretically, besides the D_{2h} -planar conformation, the two structures experimentally observed, i.e., the S_4 -ruffled tetragonal and the near-planar triclinic structures.

Geometry optimization of a highly ruffled H_2TPP structure, under C_2 symmetry constraint, leads to a S_4 -ruffled structure matching very well the experimental one,⁵⁹ except for the degree of ruffling, the theoretical and experimental average $|\Delta C_{\beta}|$ values amounting to 0.30 and 0.38 Å, respectively (note that, according to our choice of the axis, in this structure the C_2 axis is the y axis bisecting the opposite hydrogen-bonded pyrroles). Geometry optimization of a near-planar H_2TPP structure, under C_2 symmetry constraint, provides a structure that is very close to the experimental near-planar triclinic structure recently reported by Kano et al.⁶¹ In this conformation the inner hydrogens are tipped up and down by 0.145 Å with respect to the mean porphyrin plane (note that, according to our choice of the axis, in this structure the C_2 axis is the y axis bisecting the opposite hydrogen-free pyrroles) and the dihedral angles between the phenyl rings and the mean porphyrin plane amount to 62.1° and 64.6° (the corresponding experimental values are 60.8° and 63.7° respectively). Among the three explored conformations, this is the most stable one, the D_{2h} and S_4 -ruffled conformations being 0.5 and 1.6 kcal/mol higher in energy, respectively.

Table S2 summarizes the relative energies of the energy minimized $\text{H}_4\text{TPP}^{2+}$ and $[\text{H}_4\text{TPP}](\text{X})_2$ conformers. These data indicate that the D_{4h} -planar conformations are highly unstable toward nonplanar distortions. The nearly degenerate *sad* and *sadruf* conformations (the energy difference between these conformations is very small, in the range 0.3–0.7 kcal/mol) are the preferred “gas-phase” conformations, the former being the most stable in the case of the bare $\text{H}_4\text{TPP}^{2+}$ and the chloro derivative, the latter being the most stable in the case of fluoro, bromo, and iodo derivatives. Given the very small energy gap between the *sad* and *sadruf* conformers ($\sim RT$ at room temperature), an equilibrium between these two conformations is

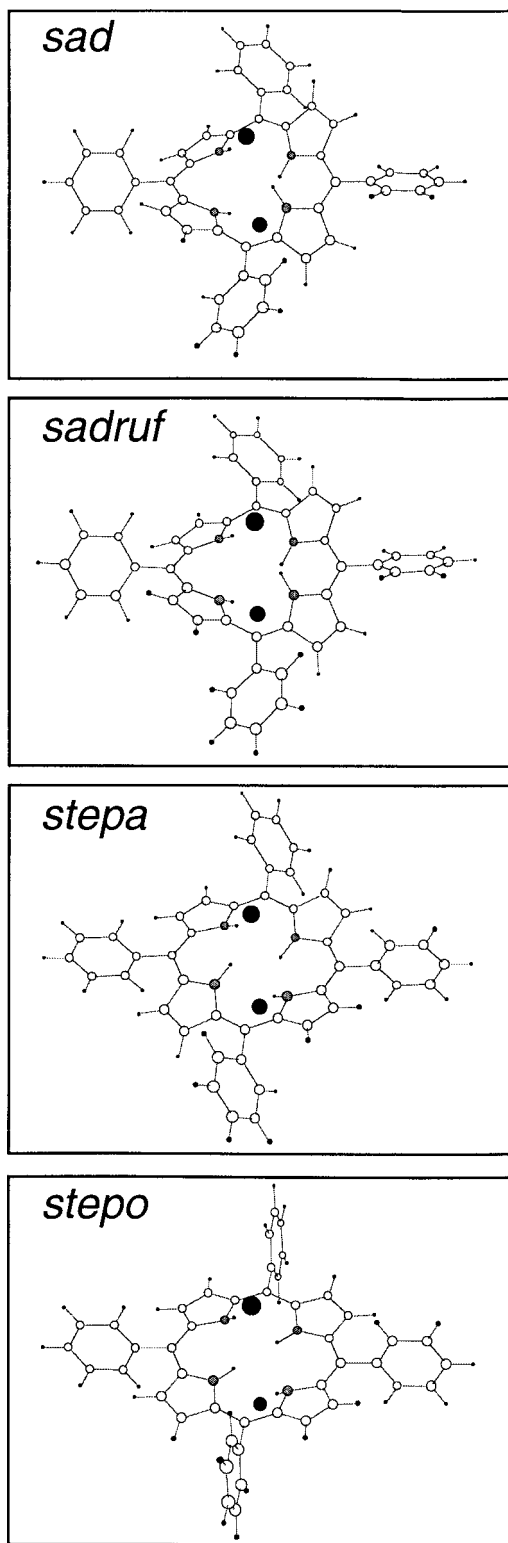

Figure 1. Optimized structures of the $[\text{H}_4\text{TPP}](\text{I}_2)$ diacid.

expected in solution. Both the C_{2h} -stepped conformations, but specially the *stepo*, are predicted to be much less stable than the *sad* and *sadruf* conformations. On these bases, we focused our investigation only on the more stable *sad* and *sadruf* conformers.

The structural parameters calculated for these conformers are gathered in Table 1 and compared to two of the three structurally characterized diacid derivatives, $[\text{H}_4\text{TPP}](\text{FeCl}_4, \text{Cl})^1$ and $[\text{H}_4\text{TPP}](\text{ClO}_4)_2$,⁸ taken as representative of an “isolated” dication (in $[\text{H}_4\text{TPP}](\text{FeCl}_4, \text{Cl})$ the only role of the counterions is to “spread

out” the dications) and of an hydrogen bonded H_2TPP diacid, respectively. As inferred from the data in Table 1, the bond angles and bond lengths predicted for the porphyrin core are nearly the same in the two conformers and, with the only exception of the N–H distance, they change very little on going from $\text{H}_4\text{TPP}^{2+}$ to the halo derivatives. Altogether these data show that the geometry of the porphyrin skeleton is not significantly influenced either by the ruffling or the counterion. This is consistent with the substantial invariance of the porphyrin core bond lengths and angles observed in $[\text{H}_4\text{TPP}](\text{FeCl}_4, \text{Cl})$ and $[\text{H}_4\text{TPP}](\text{ClO}_4)_2$. According to the pertinent dihedral angles and metrical parameters of Table 1, the saddling of the porphyrin core is large in all systems (cf. the ϕ and $|\Delta C_\beta|$ values in the table) and represents in the investigated H_2TPP diacids the major nonplanar distortion. The degree of ruffling in the *sadruf* conformers is indeed very small, especially in the halo derivatives (cf. the transannular dihedral angle $(C_\alpha\text{NNC}_\alpha)_{op}$ and the $|\Delta C_\beta|$ in the table). This is in line with the available structural data indicating that the ruffling is only a minor component of the overall nonplanarity of these systems, particularly in the hydrogen-bonded H_2TPP diacid derivatives. It is worth noting that the degree of saddling increases with increasing size of the halide, suggesting that the necessity to optimize the hydrogen bond interactions between the halides and the dication is an additional factor in determining the actual degree of saddling. It should be also noted that the degree of saddling decreases only slightly on going from the *sad* to the *sadruf* conformations.

The optimized *sad* and *sadruf* structures of the bare dication and of the halo derivatives clearly show that there is a relationship between the degree of saddling and the phenyl group orientation: more acute porphyrin–phenyl dihedral angles correlate indeed with larger out-of-plane displacements of the porphyrin β -carbons (compare the calculated $|\Delta C_\beta|$ and θ values in Table 1). Such a correlation has been observed in all three H_2TPP diacid derivatives structurally characterized. Interestingly, the calculated C_b – C_1 bond lengths decrease in the series with increasing twisting of the *meso*-phenyl groups. In the *sad* and *sadruf* structures of the diacids the C_b – C_1 distance is invariably shorter than that (1.500 Å) computed in the D_{2h} -planar structure of H_2TPP , where the phenyl rings are perpendicular to the mean porphyrin plane. The optimized C_{2h} -*steпа* structures of the bare diacid and of the halo derivatives provide further examples of the correlation between the C_b – C_1 distance and the porphyrin–phenyl dihedral angle. In all these structures, the C_b – C_1 distance predicted for the two opposite phenyl rings perpendicular to the mean porphyrin plane (C_b – $C_1 = 1.50$ Å) is larger than that predicted for the two twisted (θ in the range 50 – 55°) phenyl rings (C_b – $C_1 = 1.48$ Å). That more acute porphyrin–phenyl dihedral angles correspond to shorter C_b – C_1 bond lengths suggests increasing conjugation between the π systems of porphyrin and phenyl groups with increasing coplanarity.

Concerning the hydrogen bond parameters, from Table 1 it can be inferred that in both the *sad* and *sadruf* conformers there are nearly linear bridging hydrogen bonds between each halide and the cofacial pair of trans pyrrole NH protons. In all diacid derivatives the N–H distance is invariably longer than in the bare dication and in the parent H_2TPP as well (N–H = 1.006 Å in the most stable conformer). What we find is in line with IR studies on porphyrin diacids showing a net red shift of the N–H stretching vibration upon diacid formation.²⁵ The calculated N–H distances increase on increasing the electronegativity and on decreasing the size of the halide. As for the H–X and N–X bond distances, they increase on increasing the size of

TABLE 1: Optimized Geometrical Parameters of H_4TPP^{2+} and $[H_4TPP](X)_2$ Diacid Derivatives Compared with X-ray Data for $[H_4TPP](FeCl_4, Cl)^a$ and $[H_4TPP](ClO_4)_2^b$

	conformer ^c	H_4TPP^{2+}	$[H_4TPP](F)_2$	$[H_4TPP](Cl)_2$	$[H_4TPP](Br)_2$	$[H_4TPP](I)_2$	experimental ^d
Bond Lengths, Å							
N–H	<i>sad</i>	1.016	1.119	1.074	1.065	1.056	
	<i>sadruf</i>	1.016	1.118	1.074	1.065	1.056	
H–X	<i>sad</i>		1.395	1.973	2.167	2.436	
	<i>sadruf</i>		1.391	1.975	2.166	2.436	
N–X	<i>sad</i>		2.513	3.044	3.226	3.483	
	<i>sadruf</i>		2.509	3.045	3.225	3.482	
N–C _α	<i>sad</i>	1.393	1.371	1.373	1.374	1.376	1.39(3); ^a 1.390(9) ^b
	<i>sadruf</i>	1.393	1.371	1.372	1.373	1.376	
C _α –C _β	<i>sad</i>	1.422	1.440	1.435	1.434	1.432	1.43(3); ^a 1.431(13) ^b
	<i>sadruf</i>	1.422	1.440	1.435	1.433	1.432	
C _β –C _β	<i>sad</i>	1.380	1.367	1.369	1.370	1.371	1.35(3); ^a 1.366(11) ^b
	<i>sadruf</i>	1.380	1.367	1.369	1.370	1.371	
C _α –C _b	<i>sad</i>	1.417	1.414	1.414	1.413	1.413	1.40(3); ^a 1.414(11) ^b
	<i>sadruf</i>	1.417	1.413	1.413	1.413	1.412	
C _b –C ₁	<i>sad</i>	1.472	1.483	1.480	1.479	1.479	1.45(3); ^a 1.475(9) ^b
	<i>sadruf</i>	1.472	1.483	1.479	1.479	1.478	
Bond Angles, deg							
∠NHX	<i>sad</i>		178.8	174.3	173.1	171.4	165 ^b
	<i>sadruf</i>		177.9	174.1	172.4	170.7	
∠C _α NC _α	<i>sad</i>	109.8	108.9	109.6	109.6	109.7	108(2); ^a 110.3(10) ^b
	<i>sadruf</i>	109.8	108.9	109.5	109.6	109.6	
∠NC _α C _β	<i>sad</i>	106.6	108.0	107.5	107.4	107.3	108(2); ^a 106.1(8) ^b
	<i>sadruf</i>	106.5	108.0	107.5	107.5	107.3	
∠C _β C _β C _α	<i>sad</i>	108.4	107.5	107.7	107.8	107.9	109(2); ^a 108.7(9) ^b
	<i>sadruf</i>	108.4	107.5	107.7	107.8	107.9	
∠C _α C _b C _α	<i>sad</i>	123.0	124.9	124.1	123.8	123.6	120(2); ^a 123.2(7) ^b
	<i>sadruf</i>	122.9	125.0	124.1	123.9	123.7	
Dihedral Angles, deg, and Metrical Parameters, Å							
∠(C _α NNC _α) _{op}	<i>sad</i>	0.0	0.0	0.0	0.0	0.0	15(2); ^a 2.7 ^b
	<i>sadruf</i>	9.6	6.1	6.1	5.4	5.4	
φ	<i>sad</i>	30.6	26.1	29.1	30.4	30.1	33(2); ^a 27.9 ^b
	<i>sadruf</i>	30.5	23.9	28.7	29.9	30.4	
θ	<i>sad</i>	28.8	41.4	34.7	33.9	32.7	21(2); ^a 27(2) ^b
	<i>sadruf</i>	29.3	43.9	35.5	35.7	33.9	
ΔC _β	<i>sad</i>	0.994	0.643	0.838	0.900	0.932	1.07(11); ^a 0.93(6) ^b
	<i>sadruf</i>	0.989	0.611	0.850	0.875	0.911	
ΔC _b	<i>sad</i>	0.000	0.000	0.000	0.000	0.000	0.28(0); ^a 0.02(2) ^b
	<i>sadruf</i>	0.175	0.110	0.112	0.099	0.099	

^a Reference 1. ^b Reference 8. ^c For the *sadruf* conformers, the average values of the geometrical parameters are reported. ^d The number in parentheses is the maximum deviation from the averaged value.

the halide, a trend which parallels that of the mean crystallographic values reported by Steiner in an up-to-date database study.⁶² The calculated N–X distances (X = Cl, Br, I) are well within the range of the crystallographic values available for a number of hydrohalides, i.e., 3.03–3.22, 3.19–3.48, and 3.45–3.58 Å for hydrochlorides,^{63,64} hydrobromides,^{65,66} and hydroiodides^{67,68} respectively.

Ground-State Electronic Structure of $[H_4TPP](X)_2$ Diacid Derivatives. The highest occupied and the lowest unoccupied ground-state one-electron levels calculated for the $[H_4TPP](X)_2$ (X = F, Cl, Br, I) diacids, in their D_{2d} -saddled conformations, are shown in Figure 2 where, for comparison purpose, the ground-state one-electron levels of H_2TPP are also shown. For the $[H_4TPP](X)_2$ frontier MO's the composition in terms of H_4TPP^{2+} and X^- fragment orbitals is given in Table 2.

The salient features of the orbital level spectrum of the diacid derivatives can be understood from a fragment oriented approach where we take as building blocks the diprotonated porphyrin core, the cage of the four phenyl groups, and the two bridging halides. This approach will enable us to dissect the electronic effects of the halides, of the porphyrin core distortion, and of the twisting of the phenyl groups.

In the interaction diagram of Figure 3 the interactions between a diprotonated porphyrin core bearing an unpaired electron on each bridging carbon atom, $[H_4(PyC)_4]^{2+}$, and a cage of four

phenyl groups, $(Ph)_4$, are displayed for two orientations of the phenyl rings: (i) orthogonal to the plane of the meso-carbon atoms ($\theta = 90^\circ$); (ii) nearly coplanar with the plane of the meso-carbon atoms ($\theta = 28^\circ$). For the $(Ph)_4$ group only the two highest sets of π levels, π_1 and π_2 , are reported in the orbital diagram of Figure 3, whereas the singly occupied sp^2 -like hybrids on the C₁ atoms of the phenyl radicals that will form the electron pair bonds with the bridging atoms C_b of the porphyrin core form the high lying 12b₁, 21e, and 12a₁ levels of the $(Ph)_4$ group.

The corresponding σ hybrids on the C_b atoms of $[H_4(PyC)_4]^{2+}$ form the singly occupied 20e, 13a₁, and 8b₁. The occupied 9b₁ and 12b₂ orbitals are loosely denoted as Gouterman "a_{1u}" and Gouterman "a_{2u}", although their composition in the saddled conformation is not purely that of the typical Gouterman orbitals. The Gouterman a_{1u} character also goes into the 8b₁ orbital and will be lost from that orbital and revert completely to the 9b₁ only upon the interaction with $(Ph)_4$ and the halides, as we will describe below. Into the G-a_{2u} (G = Gouterman) derived 12b₂ MO, which normally has predominantly C_b p_z character, see ref 69, the saddling induces appreciable C_b and C_α p_{x,y} character. As inferred from the contour plot of the $[H_4(PyC)_4]^{2+}$ 12b₂ MO in the xy plane in Figure 4, this orbital has considerable amplitude in this plane, so that the π orbitals of the phenyl rings, which at $\theta = 90^\circ$ have maximum amplitude in the xy plane,

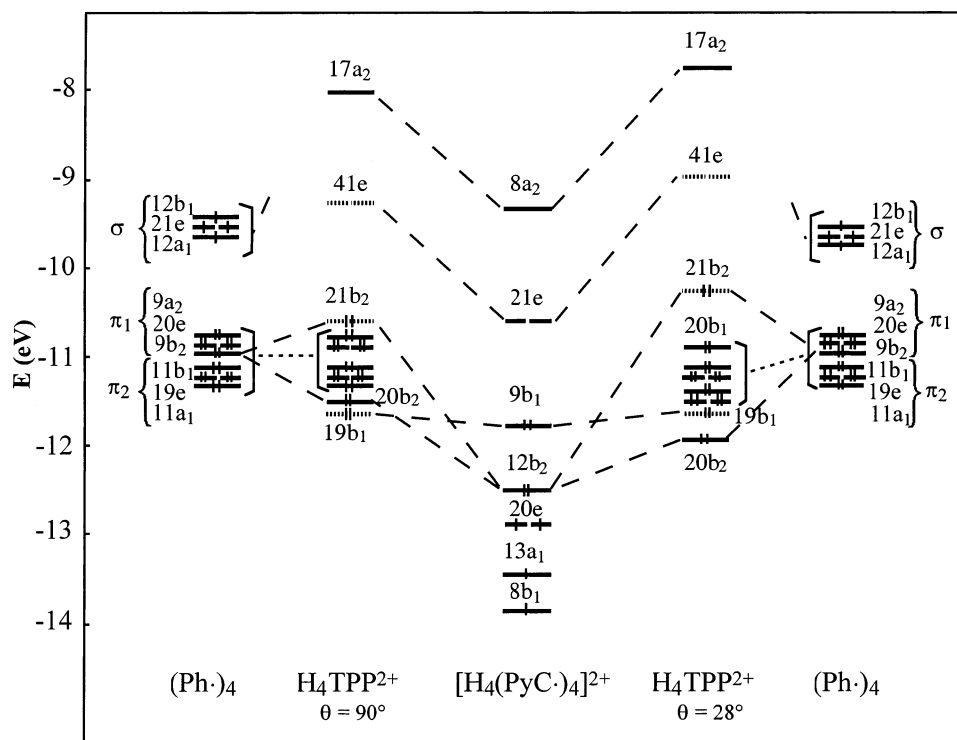

Figure 3. Orbital interaction diagram for the interaction between $[\text{H}_4(\text{PyC})_4]^{2+}$ and $(\text{Ph})_4$ fragments, at $\theta = 90^\circ$ (left side) and $\theta = 28^\circ$ (right side). The two fragments are in the same geometry they assume in $\text{H}_4\text{TPP}^{2+}$ in the optimized $D_{2d}\text{-sad}$ conformation. The $(\text{Ph})_4$ levels have been rigidly shifted to lower energy by 4.54 eV to bring them into correspondence with unperturbed orbitals of $\text{H}_4\text{TPP}^{2+}$. The $\text{H}_4\text{TPP}^{2+}$ G- a_{1u} , G- a_{2u} , and G- e_g^* derived MO's are indicated with hatched lines.

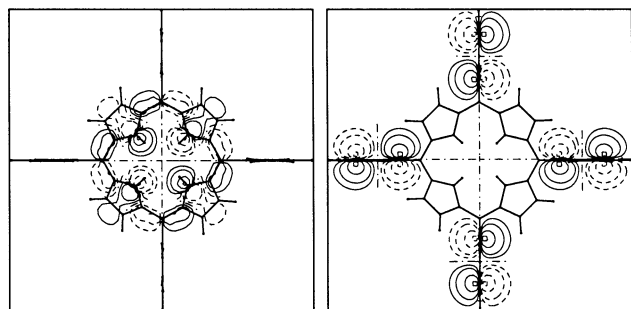

Figure 4. Contour plots of the $[\text{H}_4(\text{PyC})_4]^{2+}$ 12b₂ (left side) and $(\text{Ph})_4$ 9b₂ (right side) fragment orbitals at $\theta = 90^\circ$ in the xy plane. Contour values are 0.0, ± 0.5 , ± 0.2 , ± 0.05 , ± 0.02 , and ± 0.01 [e/bohr^3]^{1/2}. Solid and dashed contours refer to positive and negative values, respectively.

the $(\text{Ph})_4$ cage), are somewhat further destabilized at $\theta = 28^\circ$ by π out-of-plane interaction with the $(\text{Ph})_4$ 20e and 9a₂, respectively. These interactions result in a considerable phenyl to porphyrin charge transfer. Actually, at $\theta = 28^\circ$, 0.16e and 0.50e are transferred from the $(\text{Ph})_4$ 9a₂ to the $[\text{H}_4(\text{PyC})_4]^{2+}$ 8a₂ and from the $(\text{Ph})_4$ 20e to the $[\text{H}_4(\text{PyC})_4]^{2+}$ 21e, respectively. These occupied/virtual stabilizing interactions, which shift the 41e and 17a₂ orbitals slightly higher at $\theta = 28^\circ$ than at $\theta = 90^\circ$, account for the π conjugation between the *meso*-phenyl groups and the porphyrin core.

Coming now to the electronic structure modifications induced by the halides, these are apparent when comparing the orbital levels of $\text{H}_4\text{TPP}^{2+}$ displayed in the right side of Figure 3 ($\theta = 28^\circ$) with those of the $[\text{H}_4\text{TPP}](\text{X})_2$ series reported in Figure 2.

The charge redistribution following the interaction with the halides results in the destabilization of all $\text{H}_4\text{TPP}^{2+}$ levels but especially of those localized on the diprotonated porphyrin core where the positive charge resides. As a consequence, the pure or nearly pure π -phenyl orbitals end up well below the occupied Gouterman orbitals.

As for the G- a_{1u} and G- a_{2u} derived orbitals, their large energy gap caused, as discussed above, by upshift of the G- a_{2u} derived orbital induced by the phenyl rotation, is fine-tuned by the halide. When going from F to I a downward shift of the $[\text{H}_4\text{TPP}](\text{X})_2$ levels (cf. 43e) is clearly distinguishable, although not uniform. The energy lowering of the G- a_{2u} derived MO (24b₂ in F and Cl derivatives, 23b₂ in Br and I derivatives) along the series is modulated by the mixing of this orbital with the B₂ combination of the halide lone pairs. [Note that in the D_{2d} point group of the molecules the np_z and $np_{x,y}$ lone pairs, hereafter referred to as np_σ and np_π , yield combinations of A₁ and B₂ and E symmetry, respectively.] The mixing of the halide lone pairs into the $[\text{H}_4\text{TPP}](\text{X})_2$ G- a_{2u} derived MO is not surprising in view of the appreciable amplitude ($\sim 18\%$) of the $\text{H}_4\text{TPP}^{2+}$ 21b₂ on the pyrrolic nitrogens, which in the saddled conformation of the diacids are extruding out of the porphyrin plane and point just to the np_σ lobes of the bridging halides. The energy and composition of the resulting 23b₂/24b₂ bonding/antibonding pairs change along the series (see Table 2), according to the overlap and the relative energy of the interacting $\text{H}_4\text{TPP}^{2+}$ and X⁻ fragment orbitals. According to the orbital compositions of Table 2, the G- a_{2u} derived orbital is a pure or nearly pure porphyrin orbital in the fluorine and iodine derivatives (the 24b₂ and 23b₂ orbital, respectively), whereas it contains appreciable halide lone pair character in chlorine (24b₂) and bromine (23b₂) derivatives.

In summary, when comparing the one-electron levels of the $[\text{H}_4\text{TPP}](\text{X})_2$ derivatives to those of the parent H_2TPP , we note that the outstanding difference is the diminished energy gap between the G- a_{2u} and G- e_g^* derived MOs, which is due to the larger upshift of the G- a_{2u} MO in the diacids. In the level scheme of Figure 2 the destabilization of the $[\text{H}_4\text{TPP}](\text{X})_2$ G- a_{2u} relative to H_2TPP is incidentally hidden under the generalized stabilization of the levels on going from H_2TPP to $[\text{H}_4\text{TPP}](\text{X})_2$, as the positive charge on the porphyrin skeleton increases. The orbital

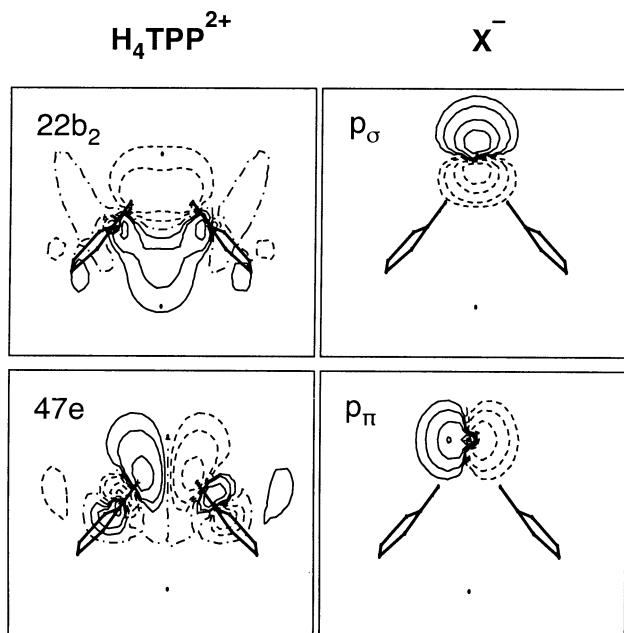

Figure 5. Contour plots of the $\text{H}_4\text{TPP}^{2+}$ $22b_2$ and $47e_{xz}$ (left side) and halide p_σ and p_π lone pair (right side) fragment orbitals in the xz plane. Contours: see caption to Figure 4.

scheme of Figure 2 also shows that the halides introduce additional levels in the valence region of the diacid derivatives. In all $[\text{H}_4\text{TPP}](\text{X})_2$, but in the fluorine derivative, the halide lone pairs are actually the highest occupied MO's. Due to the presence of halide lone pair MO's in the valence region, in the Cl, Br, and I derivatives, halide to porphyrin charge transfer (HPCT) transitions are expected to play a role in the visible region of the spectra. The fluorine lone pairs are much lower in energy, so in $[\text{H}_4\text{TPP}](\text{F})_2$ the highest occupied MO's are the G- a_{1u} and G- a_{2u} derived orbitals, the $20b_1$ and $24b_2$.

Nature of the N—H···X···H—N Bridging Hydrogen Bonds.

In this section we will clarify the nature of the hydrogen bonds in $[\text{H}_4\text{TPP}](\text{X})_2$, through electronic structure analysis and quantitative decomposition of the hydrogen bond energy into the electrostatic interaction, the repulsive orbital interactions (Pauli repulsion), and the bonding orbital interactions (charge transfer and polarization).

This type of analysis, which has been so successfully employed by Bickelhaupt et al.^{70–73} to clarify the nature of the hydrogen bonds in DNA base pairs, enables us to address fundamental questions such as: (i) can the hydrogen bonds in these systems be understood solely in terms of electrostatic interactions, as the ionic nature of the interacting fragments would suggest and (ii) how important are charge-transfer (covalent) interactions? Indeed, the mixing of $\text{H}_4\text{TPP}^{2+}$ N—H σ^* orbitals into the halide lone pairs which occur in the $[\text{H}_4\text{TPP}](\text{X})_2$ $27a_1$, $23b_2$, $24b_2$, and $41e$ MO's (see the composition of these orbitals in Table 2) provides reasons to believe that charge-transfer interactions may be an important component in the hydrogen bond energy.

Concerning these charge-transfer interactions, it should be noted that the $\text{H}_4\text{TPP}^{2+}$ and X^- fragments forming the N—H···X···H—N bridging hydrogen bonds possess the basic electronic structural features that are required in order for these interactions to occur, i.e., the σ and π lone pairs on the bridging halides pointing toward (and donating charge into) the unoccupied σ^* orbitals of the cofacial pair of trans pyrrole N—H groups. This can be inferred from the contour plots of Figure 5 illustrating how the halide p_σ and p_π lone pairs can overlap and interact

with $\text{H}_4\text{TPP}^{2+}$ N—H σ^* orbitals forming $\sigma_{\text{ip}} + \sigma_{\text{N-H}}^*$ and $\pi_{\text{ip}} + \sigma_{\text{N-H}}^*$ bonds, respectively. In the $D_{2d}\text{-sad}$ conformations of $[\text{H}_4\text{TPP}](\text{X})_2$, these interactions occur in the A_1 , B_2 , and E symmetries according to which the halide p_σ and p_π lone pairs transform (vide supra).

As inferred from the orbital interaction decomposition reported in Table 3, the ΔE_{A_1} , ΔE_{B_2} , and ΔE_E terms, which account basically for the electron donor–acceptor interactions above-mentioned (polarization is a minor component), represent most of the orbital interaction (covalent) energy (ΔE_{oi} term). Comparing the ΔE_{oi} and ΔV_{elstat} terms in Table 3, it is apparent that the covalent interactions (charge-transfer and polarization) are an important component of the hydrogen bond energy in $[\text{H}_4\text{TPP}](\text{X})_2$, especially in the fluoro derivative, where the ΔE_{oi} term is largest and the total attractive interaction ($\Delta E_{\text{oi}} + \Delta V_{\text{elstat}}$) is actually provided for 62% by electrostatic interaction and for 38% by covalent interactions. In the chloro, bromo, and iodo analogues the covalent contribution to the total attractive interaction decreases to 31%, 29%, and 28%, respectively, mainly due to the larger decrease of the ΔE_{oi} term with respect to the ΔV_{elstat} term, even if it is still relevant. These percentages hold nearly the same for the *sadruf* conformations of the $[\text{H}_4\text{TPP}](\text{X})_2$ derivatives, as inferred from Table S3, where the hydrogen bond energy terms are gathered for both the *sad* and *sadruf* conformers. The only exception in this context is $[\text{H}_4\text{TPP}](\text{Br})_2$ for which we predict a sizable increase of the ΔE_{oi} term on going from the *sad* to the *sadruf* conformation. The data in Tables 3 and S3 also show that the decrease of the covalent contribution to the hydrogen bond on going from F to I parallels the decrease of the Hirshfeld charge on the halides.

Since the total attractive interaction ($\Delta E_{\text{oi}} + \Delta V_{\text{elstat}}$) is by far larger than the Pauli repulsion orbital interactions, ΔE_{Pauli} , the ΔE_{int} term is strongly stabilizing in all members of the series. It decreases (becomes less negative), however, as the size of the halide increases, essentially because of the decrease of the ΔE_{oi} term.

Excited States and Optical Spectra. Table 4 summarizes the main spectroscopic features of the various diacid derivatives in comparison with the parent free base. Absorption intensities have been reported in terms of relative peak ratios, which have been normalized with respect to the intensity of the B band of H_2TPP . The value R is a normalization multiplicative factor. Figure 6 shows the absorption spectra of the diacid series and of the parent neutral porphyrin.

An inspection of the absorption spectra reveals that (i) the B band maxima of $[\text{H}_4\text{TPP}](\text{X})_2$ are bathochromically shifted and exhibit hypochromicity with respect to H_2TPP , (ii) the four Q bands of H_2TPP collapse to two in the diacids and shift to lower energy, (iii) relative to the parent neutral porphyrin, $[\text{H}_4\text{TPP}](\text{X})_2$ exhibits broadened and hyperchromic Q(0,0) bands, and (iv) the intensity and energy of the Q(0,0) and B(0,0) bands change significantly with the halide.

TDDFT calculations have been performed for the lowest optically allowed excited states of H_2TPP , in its C_2 near-planar triclinic conformation, and of $[\text{H}_4\text{TPP}](\text{X})_2$, in their $D_{2d}\text{-sad}$ and $C_2\text{-sadruf}$ conformations. In Table 5 the excitation energies and oscillator strengths calculated for the excited states accounting for the Q and B bands are compared to the experimental data. The data in Table 5 show that the Q and B band maxima of $[\text{H}_4\text{TPP}](\text{X})_2$ are nicely accounted for by TDDFT calculations. Although the quality of the TDDFT results for tetrapyrrole systems, including the present ones for H_2TPP , are very high,^{69,74–79} the agreement between theory and experiment is particularly impressive in the case of the $[\text{H}_4\text{TPP}](\text{X})_2$ systems,

TABLE 3: Analysis of the Hydrogen Bonds in [H₄TPP](X)₂ (X = F, Cl, Br, I) in Their *sad* Conformation

	X = F	X = Cl	X = Br	X = I
Orbital Interaction Decomposition				
ΔE_{A_1}	-45.2	-23.1	-21.8	-19.7
ΔE_{A_2}	-7.1	-4.9	-4.3	-3.5
ΔE_{B_1}	-6.7	-4.2	-3.6	-2.9
ΔE_{B_2}	-36.4	-24.7	-23.9	-22.0
ΔE_E	-121.1	-59.5	-50.7	-44.2
$\Delta E_{oi} (\sum_r \Delta E_r)$	-216.5	-116.4	-104.3	-92.3
Bond Energy Decomposition				
ΔE_{Pauli}	195.6	106.7	95.6	83.3
ΔV_{elstat}	-348.0	-262.9	-250.2	-235.2
$\Delta E_{Pauli} + \Delta V_{elstat}$	-152.4	-156.2	-154.6	-151.9
ΔE_{oi}	-216.5	-116.4	-104.3	-92.3
$\Delta E_{int} (\Delta E_{Pauli} + \Delta V_{elstat} + \Delta E_{oi})$	-368.9	-272.6	-258.9	-244.2
Halide Charge (Electrons)				
Hirshfeld ⁸⁰	-0.727	-0.797	-0.823	-0.826

TABLE 4: Absorption and Fluorescence Properties of [H₄TPP](X)₂ Diacid Derivatives in CH₂Cl₂ at 298 K

X	abs peak ratio			R ^a	fluor max, nm		
	B(0,0)	Q(1,0)	Q(0,0)		Q(0,0)	Q(0,1)	Φ_f
F	447 (1.0)	613 (0.056)	664 (0.161)	0.86	682 (1.15)	703 (1.0)	0.014
Cl	446 (1.0)	613 (0.057)	667 (0.174)	0.79	682 (1.16)	703 (1.0)	0.022
Br	451 (1.0)	615 (0.058)	668 (0.183)	0.80	686 (0.89)	707 (1.0)	0.002
I	443 (1.0)	625 (0.088)	676 (0.250)	0.53	676 (1.09)	707 (1.0)	0.0004
H ₂ TPP	419 (1.0)	515 (0.074)	550 (0.050)	1	654 (1.99)	726 (1.0)	0.13 ^b
		Q _y (1,0)	Q _y (0,0)		Q _x (0,0)	Q _x (0,1)	
		591(0.044)	647 (0.045)				
		Q _x (1,0)	Q _x (0,0)				

^a R is a multiplicative factor to obtain the molar extinction coefficient of the B band, using $\epsilon = 4.78 \times 10^5 \text{ M}^{-1} \text{ cm}^{-1}$ as reference value from H₂TPP. ^b In C₆H₆.

for which the theoretical excitation energies are in error by no more than 0.03 eV (11 nm). Although a quantitative assessment of the predicted oscillator strengths is difficult to make due to a number of factors as described in the Experimental Section, the experimental values listed in Table 5 can be regarded as useful references for qualitative comparisons. In this respect, the predicted oscillator strengths are largely consistent with the experiment.

According to the TDDFT results, the ruffling has no substantial effect on the optical spectra of the diacids. In fact, as inferred from Table 5, on going from the *sad* to the *sadruf* conformation, the ¹E states simply split into a pair of degenerate or nearly degenerate ¹B states, as a mere effect of the $D_{2d} \rightarrow C_2$ symmetry lowering. In view of the negligible impact of the ruffling on the excited states, only the TDDFT results obtained for the *sad* conformations of the diacids will be discussed.

The excitation energies and oscillator strengths calculated for the lowest optically allowed (up to ~ 3.0 eV) excited states of H₂TPP, in its near-planar triclinic conformation, and of [H₄TPP](F)₂ and [H₄TPP](X)₂ (X = Cl, Br, I) in their D_{2d} -*sad* conformations are gathered in Tables S4, S5, and 6–8, respectively. These tables also include the composition of the BP/ALDA solution vectors in terms of the major one-electron MO transitions.

Q Band. Considering first H₂TPP as point of reference for the diacids, it is worth noting that the partial lifting of the G-a_{1u}(82a) and G-a_{2u}(79b) MO's induced by the small twisting ($\theta \sim 60^\circ$) of the *meso*-phenyl rings causes the mixing of the Gouterman one-electron transitions to be much less effective than in H₂P and its metal complexes, where it is close to 50–50.⁶⁹ The ¹B excited state responsible for the Q_x band is mostly described by 79b \rightarrow 83a and the ¹A, which accounts for the Q_y band (we have a y-polarized transition which is A in the prevailing symmetry in which the main axis of symmetry has

been chosen to be the y-axis), is mostly described by 79b \rightarrow 80b, the transitions out of the G-a_{1u} MO, 82a \rightarrow 80b and 82a \rightarrow 83b, entering in these states with only a 30% weight. As a consequence, the cancellation of the transition dipoles of the Gouterman transitions that occurs in the lowest excited state(s) in porphyrins, leading to very low intensity of the Q band(s), occurs to a lesser extent in H₂TPP where the Q_x and Q_y bands have, in agreement with experiment, appreciable intensity ($f(Q_x) = 0.031, f(Q_y) = 0.061$).

Due to the considerable twisting of the phenyl rings, in [H₄TPP](X)₂ the splitting of the G-a_{1u}(20b₁) and G-a_{2u}(23(24)-b₂) is significantly larger than in the parent free base, and the Gouterman one-electron transitions, the 23(24)b₂ \rightarrow 43e and 20b₁ \rightarrow 43e, mix still less than in H₂TPP. As inferred from the composition of the BP/ALDA solution vectors reported in Tables S5 and 6–8, the ¹E states responsible for the Q-band (¹E, ³E, ³E, and ⁴E in the fluoro, chloro, bromo, and iodo derivatives, respectively) are in all diacids, but in the chloro derivative, largely described by the 23(24)b₂ \rightarrow 43e transition, the 20b₁ \rightarrow 43e enters with only a minor weight (23%, 19%, 19%, and 13% in the F, Cl, Br, and I derivatives, respectively). Due to the reduced mixing of the Gouterman configurations, the cancellation of their large transition dipoles is less effective than in H₂TPP, leading, in nice agreement with the experiment, to an intensification of the Q band ($f = 0.233, 0.241, 0.247,$ and 0.223 in the fluoro, chloro, bromo, and iodo derivatives, respectively).

In [H₄TPP](Cl)₂ and, to a lesser extent, in [H₄TPP](I)₂, the low-energy combination of the Gouterman transitions corresponding to the Q-band (what we call “the low energy combination of the Gouterman transitions” to stress the analogy with porphyrins has actually rather little weight of the 20b₁ \rightarrow 43e) undergoes further configuration interaction with nearly degenerate halide to porphyrin charge transfer (HPCT) transi-

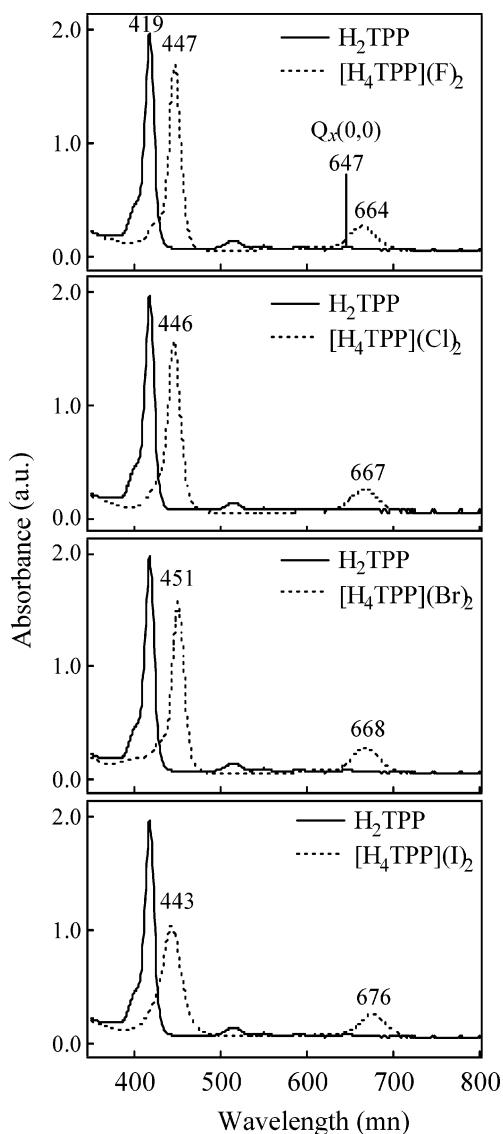

Figure 6. Absorption spectra of H_2TPP and $[\text{H}_4\text{TPP}](\text{X})_2$ ($\text{X} = \text{F}, \text{Cl}, \text{Br}, \text{I}$) diacid derivatives at room temperature in dichloromethane.

tions. As a consequence, the Q state has in these diacid derivatives a mixed $\pi\pi^*/\text{HPCT}$ character.

The observed and theoretically predicted small variations of the intensity of the Q band (cf. Table 5) with the halide can be rationalized on the basis of the following arguments: (i) the degree of mixing of the Gouterman transitions changes as the splitting of the G-a_{1u} and G-a_{2u} derived MO's changes along the series; (ii) the transition dipole of the $\text{G-a}_{2u} \rightarrow \text{G-e}_g^*$ decreases as the contribution of the halide lone pair to the G-a_{2u} increases. The $\langle 23(24)\text{b}_2|x,y|43\text{e}_{xz,yz} \rangle$ dipole matrix elements amount indeed to 3.80 au, 3.48 au, 3.53 au, and 3.81 au in the fluoro, chloro, bromo, and iodo derivatives, respectively.

As for the red shift of the Q-band in the H_2TPP diacids relative to the parent free base, this is an effect of the upshift of the G-a_{2u} derived MO. In fact, due to the upshift of the G-a_{2u} derived MO, the low-energy combination of the Gouterman transitions that accounts for the Q-band is in the diacid derivatives at lower energy than in H_2TPP . Since the energy of the G-a_{2u} derived MO is fine-tuned by the halide, the energy of the low-energy combination of the Gouterman transitions slightly varies along the series, in agreement with the experiment (cf. Table 5).

B Band. As inferred from the compositions of the excited states in Tables S5 and 6–8, in the diacids the ${}^1\text{E}$ states

responsible for the intensity of the B band ($2{}^1\text{E}$, $6{}^1\text{E}$, $6{}^1\text{E}$, and $8\text{--}9{}^1\text{E}$ in the fluoro, chloro, bromo, and iodo derivatives, respectively) are mainly described by the $20\text{b}_1 \rightarrow 43\text{e}$ transition, the lower energy Gouterman transition; $23(24)\text{b}_2 \rightarrow 43\text{e}$ entering with a minor weight. The contribution of this transition to the B states is, however, large enough to drive the high-energy combination of the Gouterman transitions to a lower energy than in H_2TPP . The shift to lower energy of the high-energy combination of the Gouterman transitions on going from H_2TPP to its diacid derivatives is just at the origin of the observed bathochromic shift of the B band in the diacids. From the $[\text{H}_4\text{TPP}](\text{X})_2$ spectra in Figure 6 the changes of the B band maxima along the series are apparent but not uniform. The sensitivity to the halide of the position of the B band has two main causes: (i) the energy of the $23(24)\text{b}_2 \rightarrow 43\text{e}$ transition and hence of the high-energy combination of the Gouterman transitions being modulated by the halide; (ii) configurational mixing of the high-energy combination of the Gouterman transitions with HPCT transitions. For instance, in $[\text{H}_4\text{TPP}](\text{Cl})_2$ and $[\text{H}_4\text{TPP}](\text{I})_2$ the high-energy combination of the Gouterman transitions undergoes further configuration interaction with a nearly degenerate HPCT transition, $41\text{e} \rightarrow 17\text{a}_2$ and $42\text{e} \rightarrow 28\text{a}_1$, respectively. As shown in Tables 6 and 8, two nearly degenerate excited states result from this configurational mixing, $5, 6{}^1\text{E}$ in $[\text{H}_4\text{TPP}](\text{Cl})_2$ and $8, 9{}^1\text{E}$ in $[\text{H}_4\text{TPP}](\text{I})_2$. $6{}^1\text{E}$ and $8{}^1\text{E}$ are dominated by the high-energy combination of the Gouterman transitions and have large oscillator strengths due to the parallel direction of the large transition dipole matrix elements of these transitions. These excited states account for most of the intensity of the B band in these diacids. $5{}^1\text{E}$ and $9{}^1\text{E}$ where the HPCT transitions enter with the largest weight have a much lower oscillator strength, although still sizable, due to the small transition dipole matrix elements of the HPCT transitions. On the basis of their energy and intensity, we believe that the $5{}^1\text{E}$ excited state of $[\text{H}_4\text{TPP}](\text{Cl})_2$ contributes to the red tail of the B band and the $9{}^1\text{E}$ of $[\text{H}_4\text{TPP}](\text{I})_2$ contributes to the intensity of the B band main peak. Deconvolution of the optical spectra of $[\text{H}_4\text{TPP}](\text{Cl})_2$ and $[\text{H}_4\text{TPP}](\text{I})_2$ indicates indeed that the B band contains at least two absorptions, which fits in with our theoretical results pointing to the presence of two excited states, $5, 6{}^1\text{E}$ in $[\text{H}_4\text{TPP}](\text{Cl})_2$ and $8, 9{}^1\text{E}$ in $[\text{H}_4\text{TPP}](\text{I})_2$ within the B band envelope.

HPCT Excited States. Our electronic structure calculations which locate the set of Cl, Br, and I lone pairs between (Cl) or above (Br, I) the occupied Gouterman orbitals, already suggest that in $[\text{H}_4\text{TPP}](\text{Cl})_2$, $[\text{H}_4\text{TPP}](\text{Br})_2$, and $[\text{H}_4\text{TPP}](\text{I})_2$ the lowest allowed HPCT transitions should lie to the red of the Q band. Explicit calculations of the excited states confirm this suggestion, as several weak HPCT excited states are computed to the red of the Q band in these diacids (cf. Tables 6–8). The presence of weak absorptions to the red of the Q band in the optical spectra of the above-mentioned diacid derivatives seems to support the theoretical findings. For instance, a broad absorption centered at about 842 nm (1.47 eV) is actually observed in the optical spectrum of $[\text{H}_4\text{TPP}](\text{Cl})_2$, when magnified. At very high concentration, weak absorptions are also observed in the optical spectra of $[\text{H}_4\text{TPP}](\text{Br})_2$ and $[\text{H}_4\text{TPP}](\text{I})_2$ to the red of the Q band. However, given the very high concentration of the solution ($>10\text{--}4\text{ M}$), it is not possible to exclude that these weak absorptions originate from aggregation phenomena, which are not easily detectable by RLS experiments. So, a definitive assessment about the nature of these absorptions is difficult.

Weak HPCT excited states are also predicted in the region between the Q and B band and to the blue of the B band.

TABLE 5: Theoretical and Experimental Excitation Energies and Oscillator Strengths (f) of the Q and B Bands of $[H_4TPP](X)_2$ and H_2TPP

X	conformer	Q					B				
		state	EDDFT		experiment ^a		state	TDDFT		experiment ^a	
			E , eV/nm	f	E , nm	f		E , eV/nm	f	E , nm	f
F	<i>sad</i>	1 ¹ E	1.89/656	0.247			2 ¹ E	2.81/441	1.845		
	<i>sadru f</i>	1 ¹ B	1.90/653	0.115	664	0.233	3 ¹ B	2.82/440	0.910	447	1.385
		2 ¹ B	1.90/653	0.114			4 ¹ B	2.82/440	0.947		
Cl	<i>sad</i>	3 ¹ E	1.89/656	0.219			6 ¹ E	2.80/443	1.590		
	<i>sadru f</i>	5 ¹ B	1.89/656	0.105	667	0.241	11 ¹ B	2.79/444	0.766	446	1.340
		6 ¹ B	1.89/656	0.118			12 ¹ B	2.79/444	0.772		
Br	<i>sad</i>	3 ¹ E	1.85/670	0.260			6 ¹ E	2.77/448	1.611		
	<i>sadru f</i>	5 ¹ B	1.86/667	0.125	668	0.247	11 ¹ B	2.77/448	0.815	451	1.249
		6 ¹ B	1.86/667	0.125			12 ¹ B	2.77/448	0.823		
I	<i>sad</i>	4 ¹ E	1.83/677	0.200			8 ¹ E	2.74/452	0.992		
	<i>sadru f</i>	7 ¹ B	1.83/677	0.099	676	0.223	15 ¹ B	2.75/451	0.567	443	1.554
		8 ¹ B	1.84/674	0.098			16 ¹ B	2.75/451	0.543		
H_2TPP		1 ¹ B	2.00/620	0.031	647	0.010	4 ¹ A	3.04/408	0.900	419	1.416
		1 ¹ A	2.12/585	0.061	550	0.020	4 ¹ B	3.08/403	0.868		

^a Data taken in dichloromethane at 298 K. The uncertainty in the measured wavelengths is ± 1.0 nm.

TABLE 6: Calculated Excitation Energies and Oscillator Strengths (f) for the Optically Allowed ¹E and ¹B₂ Excited States of $[H_4TPP](Cl)_2$ in the *sad* Conformation^a

state	composition	character	E , eV	f	assignment
1 ¹ B ₂	99 (42e \rightarrow 43e)	HPCT	1.40	0.002	
1 ¹ E	55 (24b ₂ \rightarrow 43e)	$\pi\pi^*/HPCT$	1.64	0.060	
	42 (23b ₂ \rightarrow 43e)				
2 ¹ E	100 (27a ₁ \rightarrow 43e)	HPCT	1.65	~ 0	
2 ¹ B ₂	99 (41e \rightarrow 43e)	HPCT	1.75	0.007	
3 ¹ E	52 (23b ₂ \rightarrow 43e)	$\pi\pi^*/HPCT$	1.89	0.219	Q
	28 (24b ₂ \rightarrow 43e)				
	19 (20b ₁ \rightarrow 43e)				
4 ¹ E	98 (42e \rightarrow 17a ₂)	HPCT	2.43	0.002	
5 ¹ E	83 (41e \rightarrow 17a ₂)	HPCT	2.73	0.234	B tail
	13 (20b ₁ \rightarrow 43e)				
6 ¹ E	57 (20b ₁ \rightarrow 43e)	$\pi\pi^*/HPCT$	2.80	1.590	B
	17 (41e \rightarrow 17a ₂)				
	11 (24b ₂ \rightarrow 43e)				
3 ¹ B ₂	81 (40e \rightarrow 43e)	PhPCT	2.99	~ 0	
	17 (20b ₁ \rightarrow 17a ₂)				

^a The major one-electron transitions contributing to the BP/ALDA solution vectors as well as the character of the excited states are given.

In $[H_4TPP](F)_2$, due to the quite low energy of the F lone pairs, the lowest HPCT excited states, 1¹B₂ and 3¹E, are located in the red and blue tail of the B band, respectively (cf. Table S5).

Fluorescence Spectra. As already pointed out, relative to the parent free bases, porphyrin diacids exhibit reduced fluorescence quantum yield and lifetimes. According to Chirvorniy et al.,¹² this can be related to the macrocycle distortion of the nominally planar porphyrin free bases upon protonation. Indeed, the more strongly distorted H_2TPP diacids show stronger reduction of the fluorescence than the less distorted H_2OEP diacids.

Additionally, a remarkable decrease of the fluorescence and phosphorescence quantum yield has been observed by Solovoy et al.¹¹ in $[H_2-o-TPP](X)_2$ and $[H_2OEP](X)_2$ diacids on going from X = CF₃COO to X = Cl and Br. A significant dependence of the fluorescence quantum yield on the halide is also observed in the series of H_2TPP diacids here investigated. The steady-state emission of the whole series and of the parent porphyrin have been measured in CH₂Cl₂ at room temperature. Fluorescence spectra, emission maxima and their relative intensities,

TABLE 7: Calculated Excitation Energies and Oscillator Strengths (f) for the Optically Allowed ¹E and ¹B₂ Excited States of $[H_4TPP](Br)_2$ in the *sad* Conformation^a

state	composition	character	E (eV)	f	assignment
1 ¹ B ₂	99 (42e \rightarrow 43e)	HPCT	1.00	0.001	
1 ¹ E	52 (24b ₂ \rightarrow 43e)	HPCT	1.28	0.004	
	44 (27a ₁ \rightarrow 43e)				
2 ¹ E	56 (27a ₁ \rightarrow 43e)	HPCT	1.28	0.004	
	41 (24b ₂ \rightarrow 43e)				
2 ¹ B ₂	99 (41e \rightarrow 43e)	HPCT	1.34	0.011	
3 ¹ E	73 (23b ₂ \rightarrow 43e)	$\pi\pi^*$	1.85	0.260	Q
	19 (20b ₁ \rightarrow 43e)				
	4 ¹ E	98 (42e \rightarrow 17a ₂)	HPCT	2.04	0.008
5 ¹ E	99 (41e \rightarrow 17a ₂)	HPCT	2.30	0.001	
6 ¹ E	70 (20b ₁ \rightarrow 43e)	$\pi\pi^*$	2.77	1.611	B
	15 (23b ₂ \rightarrow 43e)				
7 ¹ E	99 (42e \rightarrow 26b ₂)	HPCT	2.95	0.013	
3 ¹ B ₂	73 (40e \rightarrow 43e)	PhPCT	2.97	~ 0	
	12 (20b ₁ \rightarrow 17a ₂)				

^a The major one-electron transitions contributing to the BP/ALDA solution vectors as well as the character of the excited states are also given.

together with fluorescence quantum yields (Φ), are reported in Figure S1 and Table 5, respectively. The fluorescence spectra of the derivatives are very similar, and they resemble the two-band emission of the free base, apart from a red-shift of the Q(0,0) and a blue-shift of the Q(0,1) bands. The fluorescence quantum yield is in all these halide diacids strongly reduced with respect to the parent free base H_2TPP and, interestingly, also with respect to the diacid $[H_4TPP](CF_3COO)_2$, for which a fluorescence quantum yield of 0.11 was measured by Chirvorniy et al.¹² in toluene at room temperature. In the case of the bromo and the iodo derivatives the fluorescence emission is almost completely quenched.

The above experimental findings pose two important questions. The first is concerned with the decrease of the fluorescence upon diacid formation, a decrease that is particularly large in the case of H_2TPP diacids. The second is concerned with the marked dependence of the decrease of the fluorescence on the counterions.

An answer to the first question was provided by Chirvorniy et al.¹² who proposed a model to explain the enhanced nonradiative decay behavior of porphyrin diacids. This model includes the existence of decay funnels on the S₁ state energy surface that

TABLE 8: Calculated Excitation Energies and Oscillator Strengths (*f*) for the Optically Allowed 1E and 1B_2 Excited States of $[H_4TPP](I)_2$ in the *sad* Conformation^a

state	composition	character	<i>E</i> (eV)	<i>f</i>	assignment
1B_2	98 (42e → 43e)	HPCT	0.63	0.001	
1E	88 (24b ₂ → 43e)	HPCT	0.93	0.001	
	11 (27a ₁ → 43e)				
$^2^1E$	89 (27a ₁ → 43e)	HPCT	0.95	~0	
	11 (24b ₂ → 43e)				
$^2^1B_2$	99 (41e → 43e)	HPCT	0.99	0.020	
$^3^1E$	97 (42e → 17a ₂)	HPCT	1.68	0.002	
$^4^1E$	62 (23b ₂ → 43e)	$\pi\pi^*/HPCT$	1.83	0.200	Q
	21 (41e → 17a ₂)				
	13 (20b ₁ → 43e)				
$^5^1E$	78 (41e → 17a ₂)	HPCT/ $\pi\pi^*$	1.93	0.090	
	14 (23b ₂ → 43e)				
	7 (20b ₁ → 43e)				
$^6^1E$	98 (41e → 25b ₂)	HPCT	2.62	0.005	
$^3^1B_2$	100 (42e → 44e)	HPCT	2.65	0.001	
$^7^1E$	98 (42e → 21b ₁)	HPCT	2.68	0.019	
$^4^1B_2$	100 (42e → 45e)	HPCT	2.74	~0	
$^8^1E$	49 (20b ₁ → 43e)	$\pi\pi^*/HPCT$	2.74	0.992	B
	26 (42e → 28a ₁)				
	11 (23b ₂ → 43e)				
$^9^1E$	74 (42e → 28a ₁)	HPCT	2.75	0.357	
	17 (20b ₁ → 43e)				
	4 (23b ₂ → 43e)				
$^{10^1}E$	99 (41e → 25b ₂)	HPCT	2.85	0.010	
$^5^1B_2$	100 (41e → 44e)	HPCT	2.88	0.001	
$^{11^1}E$	88 (42e → 17a ₂)	HPCT	2.91	0.001	
	12 (41e → 21b ₁)				
$^{12^1}E$	88 (41e → 21b ₁)	HPCT	2.91	~0	
	12 (42e → 17a ₂)				
$^6^1B_2$	85 (40e → 43e)	PhPCT	2.93	~0	
	12 (20b ₁ → 17a ₂)				

^a The major one-electron transitions contributing to the BP/ALDA solution vectors as well as the character of the excited states are given.

are separated from the equilibrium conformation and other minima by activation barriers. These funnels involve configurations at which the potential energy surfaces of the ground and excited states approach more closely than at the equilibrium excited state structure(s). From those configurations, steady-state fluorescence occurs. These funnels may exist by virtue of the conformational degrees of freedom of the distorted diacid molecules. The conformational freedom is particularly large in the case of H_2TPP diacids, due not only to their larger distortion from planarity but also to their inherent flexibility induced by the presence of the phenyl rings, the rotation and tilting of which may be coupled with the nonplanarity of the macrocycle. This model offers a sound explanation for the enhanced $S_1 \rightarrow S_0$ radiationless decay in porphyrin diacids and for this enhancement being particularly large in H_2TPP diacids. Theoretical support for this model cannot be provided, however, by the present calculations. Explicit calculations of the ground- and excited-state energy surfaces would be required indeed to properly examine this issue, which is beyond the purpose of the present study. Nevertheless, the assumed inherent conformational flexibility of H_2TPP diacids, which is an important prerequisite for the photoinduced conformational changes to occur, is supported by our calculations showing that in the gas phase and at room temperature at least two highly distorted ground-state conformations are accessible for the $[H_4TPP](X)_2$ diacid derivatives.

On the contrary, the explanation provided by Solovyov et al.¹¹ for the reduced fluorescence (and phosphorescence) quantum yield observed in H_2TPP and H_2-o - TPP diacids relative to the corresponding parent free bases does not find support in our calculations. These authors have suggested that the observed

decrease of emission may derive from quenching of the S_1 (Q) state via a low-energy charge-transfer excited state involving the porphyrin and the peripheral phenyl rings, with the charge-transfer process facilitated by the nearly coplanar disposition of the phenyl groups relative to the neighboring pyrrole rings. Our TDDFT calculations show, however, that the charge-transfer excited states involving the porphyrin and the peripheral phenyl rings cannot be populated upon excitation into the Q-band. Electronic structure calculations, which locate the set of the π -phenyl orbitals well below the occupied Gouterman orbitals, already suggest that the lowest allowed PhPCT excited states should be located in all diacids of the series immediately to the blue of the B band. Explicit calculations of the excited states show that this is actually the case (cf. Tables S5 and 6–8).

Coming to the second question, i.e., the marked dependence of the emission efficiency on the nature of the counterions, the observed trend in the emission quantum yield along the series can be rationalized on the basis of our TDDFT calculations showing that in chloro, bromo, and iodo derivatives quenching of the S_1 (Q) state via low-lying singlet HPCT excited states may be effective. According to the energy-gap law, the closer the ground and these quenching HPCT excited states are, the more efficient the $S_1 \rightarrow S_0$ radiationless decay will be. Thus, in $[H_4TPP](Br)_2$ and $[H_4TPP](I)_2$ where the lowest singlet HPCT states lie only 1.0 and 0.6 eV above the ground state, respectively, the $S_1 \rightarrow S_0$ internal conversion should be quite efficient. It should not be so in the chloro derivative, where the energy gap between the ground state and the lowest HPCT state is significantly larger (1.4 eV). Our suggestions seem to conform to the observation that the fluorescence emission is still sizable in $[H_4TPP](Cl)_2$ and comparable to that of $[H_4TPP](F)_2$, where quenching HPCT states are lacking, and is almost completely quenched in the heavier halide containing diacids. Previously, Solovyov et al.¹¹ attributed the decrease of the fluorescence and phosphorescence quantum yield observed in $[H_2-o$ - $TPP](X)_2$, and $[H_2OEP](X)_2$ diacids on going from $X = CF_3COO$ to $X = Cl$ and Br to heavy-atom quenching effects. However, it is clear from our calculations that is not necessary to invoke heavy atom effects to explain the observed trend, low-lying singlet HPCT states offering in the case of the halide-containing diacids a viable decay path. Although we cannot provide phosphorescence data for the $[H_4TPP](X)_2$ series, the phosphorescence quantum yield is expected to be very low, if at all existent, in $[H_4TPP](Br)_2$ and $[H_4TPP](I)_2$. The presence of low-lying triplet HPCT excited states (not reported here) and efficient spin-orbit coupling may enhance indeed the $T_1 \rightarrow S_0$ nonradiative intersystem crossing in these diacids. The decrease of the phosphorescence quantum yield observed by Solovyov et al.¹¹ on going from $[H_2-o$ - $TPP](Cl)_2$ to $[H_2-o$ - $TPP](Br)_2$ (2.0×10^{-4} vs 1.3×10^{-4}) provides some support to our suggestion.

In summary, the enhanced radiationless decay of the excited states in H_2TPP diacids relative to the free base relies primarily on the large conformational flexibility of these systems that enables the deactivation mechanism proposed by Chirvony et al.¹² However, low-lying HPCT states offer, in the case of heavy halide counterions, additional decay paths that further enhance the radiationless decay.

Conclusions

DFT and TDDFT theoretical approaches have demonstrated to be a valuable tool to investigate the effects of porphyrin core saddling, *meso*-phenyl twisting, and counterions on the ground- and excited-state properties of H_2TPP diacids. We focused on $[H_4TPP](X)_2$ ($X = F, Cl, Br, I$) diacid derivatives because they

can be regarded as an ideal series for exploring the additional effects of the size and nature of the hydrogen-bonded anions on the structural and spectroscopic properties of these species.

We have found that the nearly degenerate purely saddled (*sad*) and hybrid, saddled with a small superimposed ruffling (*sadruf*), conformations are the preferred “gas-phase” conformations among several choices, both for the bare diacid, H_4TPP^{2+} , and the $[H_4TPP](X)_2$ series. DFT calculations well reproduce X-ray data available for H_2TPP diacids. In both the *sad* and *sadruf* conformers, nearly linear bridging hydrogen bonds between each halide and the cofacial pair of trans pyrrole NH protons occur. Electronic structure analysis and quantitative decomposition of the hydrogen bond energy reveal that the covalent interactions are a relevant component of the hydrogen bond energy, specially in the fluoro derivative where the ΔE_{oi} term is largest and the total attractive interaction ($\Delta E_{oi} + \Delta V_{elstat}$) is actually provided for 62% by electrostatic interaction and for 38% by covalent interactions. The hydrogen bond analysis gives deep insight into the electronic factors governing the function of tetrapyrrole systems as anion receptors. A fragment oriented approach shows that, due to the combined effect of the porphyrin core distortion and twisting of the phenyls, the π -system of phenyls and porphyrin strongly interact, leading to an upshift of the $G-a_{2u}$ and, hence, to a significant splitting of the occupied Gouterman orbitals. The diminished $G-a_{2u}/G-e_g^*$ gap and the lifting of the a_{2u}/a_{1u} degeneracy are responsible for the red shift of the Q and B bands and the hyperchromicity of the Q band in the diacids. Apart from the Gouterman orbitals, the set of highest occupied orbitals of the diacids comprise the set of halide lone pair orbitals, which move from completely above the Gouterman orbitals (I^- counterion) to below them (F^-). The lowest HPCT transitions are predicted to the red of the Q band for Cl^-I^- , but with very low intensity. The intensity and energy of the Q and B bands, together with the trend in the fluorescence quantum yield along the series, are nicely reproduced and interpreted by TDDFT calculations. Our results for H_2TPP diacids may be important to interpret the static photophysical properties of neutral highly distorted peripherally crowded porphyrins.

Acknowledgment. A.R., G.R., and E.J.B. are grateful to the National Computing Facilities foundation (NCF) of The Netherlands foundation for Scientific Research (NWO) for a grant of computer time. L.M.S. and A. Romeo thank MIUR-PRIN COFIN 2002 for financial support.

Supporting Information Available: 1H NMR data for H_2TPP and $[H_4TPP](X)_2$ ($X = F, Cl, Br, I$) (Table S1), relative energy of optimized *sad* and *sadruf* conformations of H_4TPP^{2+} and $[H_4TPP](X)_2$ (Table S2), hydrogen bond energy terms for *sad* and *sadruf* $[H_4TPP](X)_2$ conformers (Table S3), calculated excitation energies and oscillator strengths for HTPP and $[H_4TPP](F)_2$ (Tables S4 and S5, respectively), coordinates of the optimized structures of $[H_4TPP](X)_2$ in the planar (D_{4h}), *stepta* (C_{2h}), and *stepo* (C_{2h}) conformations and of H_2TPP , and RLS (Figure S1), fluorescence emission spectra (Figure S2), and deconvoluted UV-vis absorption spectra (Figure S3-S12) of $[H_4TPP](X)_2$ ($X = F, Cl, Br, I$) and H_2TPP in CH_2Cl_2 at 298 K. This material is available free of charge via the Internet at <http://pubs.acs.org>.

References and Notes

- (1) Stone, A.; Fleischer, E. B. *J. Am. Chem. Soc.* **1968**, *90*, 2735.
- (2) Sheldrick, W. S. *J. Chem. Soc., Perkin Trans.* **1976**, *2*, 453.
- (3) Cetinkaya, E.; Johnson, A. W.; Lappert, M. F.; McLaughlin, G. M.; Muir, K. W. *J. Chem. Soc., Dalton Trans.* **1974**, 1237.
- (4) Navaza, A.; deRango, C.; Charpin, P. *Acta Crystallogr., Sect. C* **1983**, *C39*, 1625.
- (5) Nguyen, L. T.; Senge, M. O.; Smith, K. M. *Tetrahedron Lett.* **1994**, *35*, 75.
- (6) Senge, M. O.; Forsyth, T. P.; Nguyen, L. T.; Smith, K. M. *Angew. Chem., Int. Ed. Engl.* **1994**, *33*, 2485.
- (7) Barkigia, K. M.; Fager, J.; Berber, M. D.; Smith, K. M. *Acta Crystallogr., Sect. C* **1995**, *C51*, 511.
- (8) Cheng, B.; Munro, O. Q.; Marques, H. M.; Scheidt, W. R. *J. Am. Chem. Soc.* **1997**, *119*, 10732.
- (9) Austin, E.; Gouterman, M. *Bioinorg. Chem.* **1978**, *9*, 281.
- (10) Kalyanasundaram, K. *Inorg. Chem.* **1984**, *23*, 2453.
- (11) Knyukshto, V. N.; Solovyov, K. N.; Egorova, G. D. *Biospectroscopy* **1998**, *4*, 121.
- (12) Chirvony, V. S.; van Hoek, A.; Galievsky, V. A.; Sazanovich, I. V.; Schaafsma, T. J.; Holten, D. *J. Phys. Chem. B* **2000**, *104*, 9909.
- (13) Ohno, O.; Kaizu, Y.; Kobayashi, H. *J. Chem. Phys.* **1993**, *99*, 4128.
- (14) Misawa, K.; Kobayashi, T. *J. Chem. Phys.* **1999**, *110*, 5844.
- (15) McDermott, G.; Prince, S. M.; Freer, A. A.; Hawthorthwaite-Lawless, A. M.; Papiz, M. Z.; Cogdell, R. J.; Isacs, N. W. *Nature* **1995**, *374*, 517.
- (16) Sparks, L. D.; Medforth, C. J.; Park, M.-S.; Chamberlain, J. R.; Ondrias, M. R.; Senge, M. O.; Smith, K. M.; Schelnutt, J. A. *J. Am. Chem. Soc.* **1993**, *115*, 581.
- (17) Medforth, C. J.; Senge, M. O.; Smith, K. M.; Sparks, L. D.; Schelnutt, J. A. *J. Am. Chem. Soc.* **1992**, *114*, 9859.
- (18) Spyroulias, G. A.; Despotopoulos, A. P.; Raptopoulou, C. P.; Terzis, A.; de Montauzon, D.; Poiblan, R.; Coutsolelos, A. G. *Inorg. Chem.* **2002**, *41*, 4648.
- (19) Vitasovic, M.; Gouterman, M.; Linschitz, H. *J. Porphyrins Phthalocyanines* **2001**, *5*, 191.
- (20) DiMaggio, S. G.; Wertsching, A. K.; Ross, C. R., II *J. Am. Chem. Soc.* **1995**, *117*, 8279.
- (21) Wasbotten, I. H.; Conradie, J.; Ghosh, A. *J. Phys. Chem. B* **2003**.
- (22) Wertsching, A. K.; Koch, A. S.; DiMaggio, S. G. *J. Am. Chem. Soc.* **2001**, *123*, 3932.
- (23) Ryeng, H.; Ghosh, A. *J. Am. Chem. Soc.* **2002**, *124*, 8099.
- (24) Haddad, R. E.; Gazeau, S.; P'ecat, J.; Marchon, J.-C.; Medforth, C. J.; Schelnutt, J. A. *J. Am. Chem. Soc.* **2003**, *125*, 1253.
- (25) Ogoshi, H.; Watanabe, E.; Yoshida, Z. *Tetrahedron* **1973**, *29*, 3241.
- (26) Nishimoto, J.; Tabata, M.; Eguchi, T.; Takauchi, J. *J. Chem. Soc., Perkin Trans.* **1998**, *2*, 1539.
- (27) Karaman, R.; Bruce, T. C. *Inorg. Chem.* **1992**, *31*, 2455.
- (28) Monsù Scolaro, L.; Romeo, A.; Castriciano, M.; G., D. L.; Patanè, S.; Micali, N. *J. Am. Chem. Soc.* **2003**, *125*, 2040.
- (29) McHugh, A. J.; Gouterman, M. *Theor. Chim. Acta* **1969**, *13*, 249.
- (30) Moriya, Y.; Amano, R.; Sato, T.; Nakata, S.; Ogawa, N. *Chem. Lett.* **2000**, 556.
- (31) Pasternack, R. F.; Collings, P. J. *Science* **1995**, *269*, 935.
- (32) Parkash, J.; Robblee, J. H.; Agnew, J.; Gibbs, E. J.; Collings, P. J.; Pasternack, R. F.; dePaula, J. C. *Biophys. J.* **1998**, *74*, 2089.
- (33) Baerends, E. J.; Ellis, D. E.; Ros, P. *Chem. Phys.* **1973**, *2*, 41.
- (34) te Velde, G.; Baerends, E. J. *J. Comput. Phys.* **1992**, *99*, 84.
- (35) Fonseca Guerra, C.; Snijders, J. G.; te Velde, G.; Baerends, E. J. *Theor. Chem. Acc.* **1998**, *99*, 391.
- (36) Casida, M. E. In *Recent Advances in Density Functional Methods*; Chong, D. P., Ed.; World Scientific: Singapore, 1995; Vol. 1; p 155.
- (37) Gross, E. U. K.; Dobson, J. F.; Petersilka, M. *Density Functional Theory. In Density Functional Theory*; Springer Series “Topics in Current Chemistry”; Nalewajski, R. F., Ed.; Springer: Heidelberg, 1996.
- (38) van Gisbergen, S. J. A.; Snijders, J. G.; Baerends, E. J. *Comput. Phys. Commun.* **1999**, *118*, 119.
- (39) Gross, E. U. K.; Kohn, W. *Adv. Quantum Chem.* **1990**, *21*, 255.
- (40) Gross, E. U. K.; Ullrich, C. A.; Gossmann, U. J. *Density Functional Theory of Time-Dependent Systems. In Density Functional Theory of Time-Dependent Systems*; NATO ASI Series B; Plenum: New York, 1995; Vol. 337; p 149.
- (41) van Gisbergen, S. J. A.; Snijders, J. G.; Baerends, E. J. *J. Chem. Phys.* **1995**, *103*, 9347.
- (42) Vosko, S. H.; Wilk, L.; Nusair, M. *Can. J. Phys.* **1980**, *58*, 1200.
- (43) Becke, A. *Phys. Rev. A* **1988**, *38*, 3098.
- (44) Perdew, J. P. *Phys. Rev. B* **1986**, *33*, 8822 (Erratum: PRB 34 1986 7406).
- (45) Chang, C.; Pelissier, M.; Durand, P. *Phys. Scr.* **1986**, *34*, 394.
- (46) Heully, J.-L.; Lindgren, I.; Lindroth, E.; Lundqvist, S.; M'artensson-Pendrill, A.-M. *J. Phys. B* **1986**, *19*, 2799.
- (47) van Lenthe, E.; Baerends, E. J.; Snijders, J. G. *J. Chem. Phys.* **1993**, *99*, 4597.
- (48) van Lenthe, E.; Baerends, E. J.; Snijders, J. G. *J. Chem. Phys.* **1994**, *101*, 9783.

- (49) van Lenthe, E.; Ehlers, A. W.; Baerends, E. J. *J. Chem. Phys.* **1999**, *110*, 8543.
- (50) ADF "STO basis set database available on line at <http://tc.chem.vu.nl/SCM/Doc/atomicdatabase>,".
- (51) KS DFT.; *Predicting and understanding chemistry*; Bickelhaupt, F. M., Baerends, E. J., Eds.; Wiley: New York, 2000; Vol. 15, pp 1–86.
- (52) Kitaura, K.; Morokuma, K. *Int. J. Quantum Chem.* **1976**, *10*, 325.
- (53) Morokuma, K. *J. Chem. Phys.* **1971**, *55*, 1236.
- (54) Ziegler, T.; Rauk, A. *Theor. Chim. Acta* **1977**, *46*, 1.
- (55) Allred, A. L. *J. Inorg. Nucl. Chem.* **1961**, *17*, 215.
- (56) *The Nature of the Chemical Bond*, 3rd ed.; Pauling, L., Ed.; Cornell University Press: Ithaca, NY, 1960.
- (57) Silvers, S.; Tulinsky, A. *J. Am. Chem. Soc.* **1964**, *86*, 927.
- (58) Silvers, S.; Tulinsky, A. *J. Am. Chem. Soc.* **1967**, *89*, 3331.
- (59) Hamor, M. J.; Hamor, T. A.; Hoard, J. L. *J. Am. Chem. Soc.* **1964**, *86*, 1938.
- (60) Senge, M. O.; Kalish, W. W. *Inorg. Chem.* **1997**, *36*, 6103.
- (61) Kano, K.; Fukuda, K.; Wakami, H.; Nishiyabu, R.; Pasternack, R. F. *J. Am. Chem. Soc.* **2000**, *122*, 7494.
- (62) Steiner, T. *Acta Crystallogr. B* **1998**, *54*, 456.
- (63) Kistenmacher, T. J.; Shigematsu, T. *Acta Crystallogr. B* **1974**, *30*, 1528.
- (64) Dunitz, J. D.; Venkatesan, K. *Helv. Chim. Acta* **1961**, *44*, 2033.
- (65) Struckmeier, G.; Engel, J.; Thewalt, U. *Z. Naturforsch., Teil B* **1978**, *33*, 753.
- (66) Apgar, P. A.; Ludwig, M. L. *J. Am. Chem. Soc.* **1972**, *94*, 964.
- (67) Kaneko, K.; Katsuhana, T.; Mitsuhashi, H.; Chen, Y.-P.; Hsu, H.-Y.; Shiro, M. *Tetrahedron Lett.* **1986**, *27*, 2387.
- (68) Mattia, C. A.; Mazzarella, L.; Vitagliano, V.; Puliti, R. *J. Crystallogr. Spectrosc. Res.* **1984**, *14*, 71.
- (69) Baerends, E. J.; Ricciardi, G.; Rosa, A.; van Gisbergen, S. J. A. *Coord. Chem. Rev.* **2002**, *230*, 5.
- (70) Fonseca Guerra, C.; Bickelhaupt, F. M. *Angew. Chem., Int. Ed. Engl.* **1999**, *38*, 2942.
- (71) Fonseca Guerra, C.; Bickelhaupt, F. M.; Snijders, J. G.; Baerends, E. J. *J. Chem. Eur. J.* **1999**, *5*, 3581.
- (72) Fonseca Guerra, C.; Bickelhaupt, F. M.; Snijders, J. G.; Baerends, E. J. *J. Am. Chem. Soc.* **2000**, *122*, 4117.
- (73) Fonseca Guerra, C.; Bickelhaupt, F. M. *J. Chem. Phys.* **2003**, *119*, 4262.
- (74) van Gisbergen, S. J. A.; Rosa, A.; Ricciardi, G.; Baerends, E. J. *J. Chem. Phys.* **1999**, *111*, 2505.
- (75) Ricciardi, G.; Rosa, A.; van Gisbergen, S. J. A.; Baerends, E. J. *J. Phys. Chem. A* **2000**, *104*, 635.
- (76) Ricciardi, G.; Rosa, A.; Baerends, E. J. *J. Phys. Chem. A* **2001**, *105*, 5242.
- (77) Rosa, A.; Ricciardi, G.; Baerends, E. J.; van Gisbergen, S. J. A. *J. Phys. Chem. A* **2001**, *105*, 3311.
- (78) Ricciardi, G.; Rosa, A.; Baerends, E. J.; van Gisbergen, S. J. A. *J. Am. Chem. Soc.* **2002**, *124*, 12319.
- (79) Nguyen, K. A.; Pachter, R. *J. Chem. Phys.* **2001**, *114*, 10757.
- (80) Hirshfeld, F. L. *Theor. Chim. Acta* **1977**, *44*, 129.