

## Excited States and Two-Photon Absorption of Some Novel Thiophenyl Pt(II)–Ethyne Derivatives

Eirik Glimsdal,<sup>\*,†</sup> Marcus Carlsson,<sup>‡</sup> Bertil Eliasson,<sup>‡</sup> Boris Minaev,<sup>†</sup> and Mikael Lindgren<sup>†</sup>

Department of Physics, Norwegian University of Science and Technology (NTNU), NO-7491, Trondheim, Norway, and Department of Chemistry, Umeå University, SE-901 87 Umeå, Sweden

Received: June 8, 2006; In Final Form: October 20, 2006

The photophysical characterization of two new compounds related to bis((4-(phenylethynyl)phenyl)ethynyl)-bis(tributylphosphine)platinum(II), here abbreviated Pt1, is reported. For the first new compound ATP1, the inner phenyl rings (closer to the Pt atom) in Pt1 are replaced by thiophene rings bridging at the 2,5-positions. In compound ATP2, the outer phenyl groups are replaced by thiophene rings bonded at the 2-position. Specifically, we report on the fluorescence quantum yield, two-photon absorption, triplet decay times and two-photon absorption induced emission spectra of the molecules in THF solutions. The results were compared with those of Pt1 and Pt1 capped with an acetone-protected 2,2-bis(methylol)propionic acid (bis-MPA) ester group (Pt1-G1). The photophysical properties of the organic dye 7-(diethylamino)coumarin (Coumarin 110) were determined and used as a reference material. The two-photon absorption cross section around 720–740 nm of ATP1 and ATP2 was found to be of the same order of magnitude as for Pt1-G1, i.e., between 5 and 10 GM, but slightly larger for ATP1 than for ATP2 (1 GM = 1 Göppert-Mayer =  $10^{-50}$  (cm<sup>4</sup> s)/photon). The fluorescence decay time of all compounds was found to be very short (subnanosecond) with quantum yields 0.0045, 0.0007, 0.0011 and 0.0020 for ATP1, ATP2, Pt1-G1 and Pt1, respectively, measured at excitation wavelength 373 nm. Just as Pt1 and Pt1-G1, both thiophenyl derivatives showed large intersystem crossing capabilities and phosphorescence, characteristic for a triplet state that can enhance the nonlinear absorption and optical power limiting by triplet state absorption. The phosphorescence emission of the thiophenyl derivatives was red-shifted in comparison with Pt1 and Pt1-G1, and the phosphorescence decay times were on the order of 200–500 ns, as for the Pt1 compound.

### 1. Introduction

Among several types of organometallic complexes, the transition metal acetylides have attracted large interest due to their special nonlinear and photophysical properties. A heavy metal atom inserted into an organic molecular structure often gives electronic interaction between the transition metal and the organic molecular framework and therefore an extended  $\pi$ -electron delocalization.<sup>1–4</sup> Such materials may possess relatively strong intersystem crossing (ISC) to triplet levels, resulting in the possibility of strong excited-state absorption, a characteristic useful for optical power limiting (OPL).<sup>5–11</sup>

An interesting class of conjugated molecules is platinum(II) alkynyl complexes, reported by Sonogashira and co-workers.<sup>12,13</sup> Organometallic platinum compounds show large NLO effects and have promising OPL properties.<sup>5–11</sup> Pt–acetylides generally have high linear transmission in most parts of the visible region (above approximately 450 nm) and significant nonlinear absorption over a wide spectral region and are therefore particularly suitable for OPL applications. The heavy Pt atom introduces a strong spin–orbit coupling, which promotes an efficient ISC between the singlet and triplet energy levels. A good optical power limiting performance can result from efficient two-photon absorption (TPA) and from excited-state absorption (ESA) having a larger transition moment than that of the ground state.

Interesting examples of ESA involve absorption by a triplet state, reached by ISC from the initially populated singlet. An example of a (*trans*-arylethynyl)platinum complex that has been widely studied for its OPL properties is bis((4-(phenylethynyl)phenyl)ethynyl)bis(tributylphosphine)platinum(II), here denoted Pt1.<sup>5–10,14–16</sup>

The introduction of various heteroatoms in conjugated polymers is a well-known approach, not only to change their electronic and optical properties but also to increase chemical stability and introduce flexibility for further molecular engineering. For such purposes we recently reported on the synthesis, molecular structure and optical limiting capability of two new thiophenyl-containing Pt(II)-acetylide complexes, ATP1 and ATP2 in Figure 1.<sup>17</sup> With thiophene units introduced at various positions over the conjugated framework the electronic levels and interplay with the central Pt(II) ion is expected to be altered. This might also lead to modifications of the triplet manifold and enhanced OPL properties at new wavelength bands. In this study the focus is on the experimental photophysical properties of these new molecular systems in THF solutions, in particular the nonlinear two-photon absorption properties and emission of the triplet state.

### 2. Methodology

**2.1. Materials and Sample Preparation.** The synthesis of the ATP1 and ATP2 molecules is described by Lind et al.<sup>17</sup> The preparation and photophysics of the Pt1 type of compounds have been reported by McKay and Staromlynska et al.<sup>5–10</sup> (unsubstituted), and by Vestberg and Lindgren et al.<sup>14–16</sup> (bis-

\* To whom correspondence should be addressed. Tel: +47 73 59 33 67. Fax: +47 73 59 77 10. E-mail: eirik.glimsdal@ntnu.no.

<sup>†</sup> Norwegian University of Science and Technology (NTNU).

<sup>‡</sup> Umeå University.



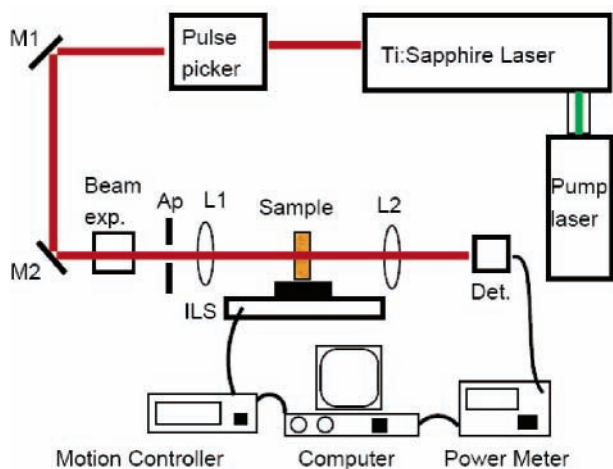

**Figure 3.** Schematic experimental setup of the z-scan. Femtosecond laser, pulse picker, and z-scan measurement collection and controlling components, are shown. An aperture is shown to selectively limit the beam to an appropriate size. See details in text.

To detect the transmitted light, a Newport 918-SL Low Power Photo Detector connected to a Newport Power Meter Model 2930C was used. The sample was placed in a sample holder upon a linear translation stage (Newport (M-)ILS Travel Linear Stage) connected to a Newport Universal Motion Controller/Driver Model ESP300. By connecting the detector and travel stage to a computer, we could control both the power reading and sample position simultaneously. To do this, an operation program was written in LabView 7.0 (National Instruments).<sup>25</sup> A long pass filter (Melles Griot) with cutoff at 590 nm was placed in front of the detector to remove any stray light due to luminescence.

**2.4. Z-scan Theory.** Because the z-scan samples were about 4–5 Rayleigh lengths thick, it was necessary to use an analysis appropriate in the thick sample limit. The z-scan data were analyzed using the analytical expression developed by Hermann et al.<sup>26</sup> given by

$$P(z) = 1 - \frac{1}{2}Q_{OR} \left\{ (1 + \alpha_0 \xi_0) [\tan^{-1}(\zeta + \xi_0) - \tan^{-1}(\xi_0)] - \frac{1}{2} \alpha_0 \ln \left[ \frac{1 + (\zeta + \xi_0)^2}{1 + \xi_0^2} \right] \right\} \quad (2)$$

where  $\zeta = L/(n_0 z_R)$ ,  $\xi_0 = z/z_R$ ,  $Q_{OR} = \beta I(0, z, z_0) n_0 z_R$  and  $\alpha_0 = \alpha_0 n_0 z_R$ . Here,  $L$  is the thickness of the sample,  $n_0$  is the refractive index of the medium,  $z_R$  is the Rayleigh length,  $\beta$  is the two-photon absorption coefficient,  $\alpha_0$  is the linear absorption

coefficient, and  $z$  is the sample distance from the beam focus. The expression in eq 2 is the instantaneous transmitted power, and by integration over the temporal pulse profile (assumed Gaussian), the transmitted pulse power is achieved. Then an extra factor  $1/\sqrt{2}$  must be introduced in the expression for  $Q_{OR}$ .

The analysis based on eq 2 was checked with our previous model based on the Crank–Nicholson approach to numerically solve the beam propagation and nonlinear absorption.<sup>27–30</sup> The two techniques were found to give identical results in simulations.<sup>14</sup>

### 3. Experimental results

**3.1. Absorption and Luminescence Properties.** The measured photophysical parameters are all collected in Table 1, to be further discussed below. Both ATP1 and ATP2 are quite transparent in the visible region with absorption maxima at 378 and 362 nm, respectively.<sup>17</sup> In comparison to Pt1-G1 the absorption spectra of ATP1 and ATP2 are slightly red-shifted (21 and 5 nm, respectively), and the extinction coefficients are all in the same order of magnitude ( $\sim 10^5 \text{ M}^{-1} \text{ cm}^{-1}$ ). ATP2 showed the same fluorescence peak as Pt1-G1 ( $\sim 390 \text{ nm}$ ) but the two phosphorescence peaks are red-shifted from 525 and 560 nm for Pt1-G1, to 550 and 590 nm for ATP2.<sup>17</sup> ATP1 showed red-shifted fluorescence around 420 nm and weak phosphorescence peaks around 610 nm and above.

The fluorescence decay time of ATP1, ATP2 and Pt1-G1 is very short. They all have a two-component contribution, where the short subnanosecond component is the overall dominant one (see Table 1). The phosphorescence decay time was measured to be approximately 190 ns for ATP1, 330 ns for ATP2 and 520 ns for Pt1-G1, using an excitation wavelength at 380 nm and 100 kHz prf, all measured at the maximum of their phosphorescence spectrum.<sup>17</sup>

To determine the fluorescence quantum efficiency and two-photon excitation efficiency from fluorescence, a suitable reference material was needed. The laser-dye Coumarin 110 (C110) was found to have photophysical properties to make it suitable as a reference in characterization of Pt–acetylide derivatives.<sup>25</sup> The linear absorption and emission spectra for C110 dissolved in THF are shown in Figure 4a. It absorbs and emits fluorescence in the same wavelength range as the Pt–acetylides discussed here and is hereby a suitable reference for both quantum yield measurements and characterization of two-photon absorption based on fluorescence emission.

The extinction coefficient at 370 nm is approximately  $24\,500 \text{ M}^{-1} \text{ cm}^{-1}$ , and the lifetime of the excited-state is 2.4 ns. The TPA cross-section was found to be around 6–8 GM at 720–760 nm and further decreased toward 800 nm (1 GM = 1 Göppert-Mayer =  $10^{-50} \text{ cm}^4 \text{ s}/\text{photon}$ ). Data are plotted in

**TABLE 1: Absorption and Emission Maxima, Quantum Efficiencies, TPA Cross Sections, and Photophysical Properties of ATP1, ATP2, Pt1-G1, and Coumarin 110.**

| molecule | abs max. (nm) | emission max. (nm) | QE     | TPA cross sections [GM <sup>a</sup> ] |        |       | fluorescence lifetime                     | phosphorescence lifetime <sup>b</sup> (ns) |
|----------|---------------|--------------------|--------|---------------------------------------|--------|-------|---|--|
|          |               |                    |        | 1 MHz                                 | 40 kHz | 9 kHz |   |  |
| ATP1     | 378           | 420                | 0.0045 | 17                                    | 14     | 7.1   | <1 ps <sup>c</sup> (94%)<br>0.45 ns (6%)  | 190  |
| ATP2     | 362           | 390                | 0.0007 | 9.5                                   | 6.8    | 5.5   | 2.8 ps (99%)<br>0.34 ns (<1%)             | 330  |
| Pt1-G1   | 357           | 390                | 0.0011 | 15                                    | 11     | 8.9   | <1 ps <sup>c</sup> (90%)<br>0.35 ns (10%) | 520  |
| Pt1      | 353           | 396                | 0.0020 | 7.0                                   |        |       |   | ca. 500                                    |
| C110     | 370           | 423                | 0.6    | 7.0                                   |        |       | 2.4 ns                                    |  |

<sup>a</sup> 1 GM =  $10^{-50} \text{ cm}^4 \text{ s}/\text{photon}$ . <sup>b</sup> Approximately values that vary with the degree of solvent oxygen quenching. <sup>c</sup> Too short of a decay time to be analyzed.

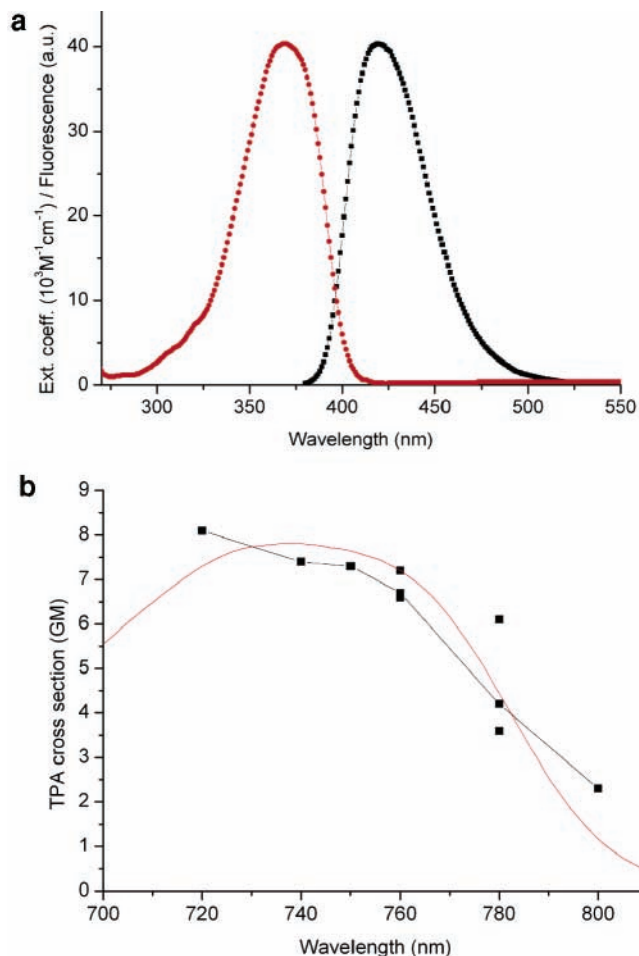

**Figure 4.** (a) Absorption (red dots) and emission (black squares) spectra of 10  $\mu\text{M}$  Coumarin 110 in THF. The absorption peak is at 370 nm, and the fluorescence emission peak is at 423 nm (excited at 350 nm). (b) TPA cross-section obtained from femtosecond z-scan measurements for different excitation wavelengths. The single absorption spectrum (arbitrary units) is also plotted at twice its original wavelength for comparison (solid line).

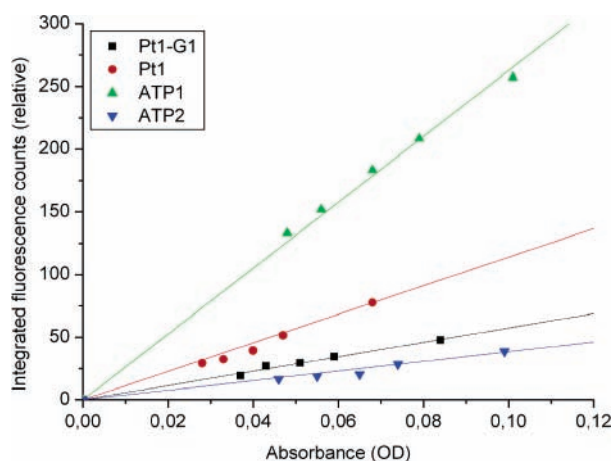

**Figure 5.** Relative quantum efficiency measurements of ATP1, ATP2, Pt1 and Pt-G1. QE values are proportional to the gradient of the curves. Reference data for Coumarin 110 are not shown.

Figure 4b together with the linear absorption spectra (arbitrary units) at half the original frequency.

The quantum efficiency was determined by measuring absorbance and integrated fluorescence at various concentrations. Results of such measurements are plotted in Figure 5, where the gradient of the curves becomes proportional to the

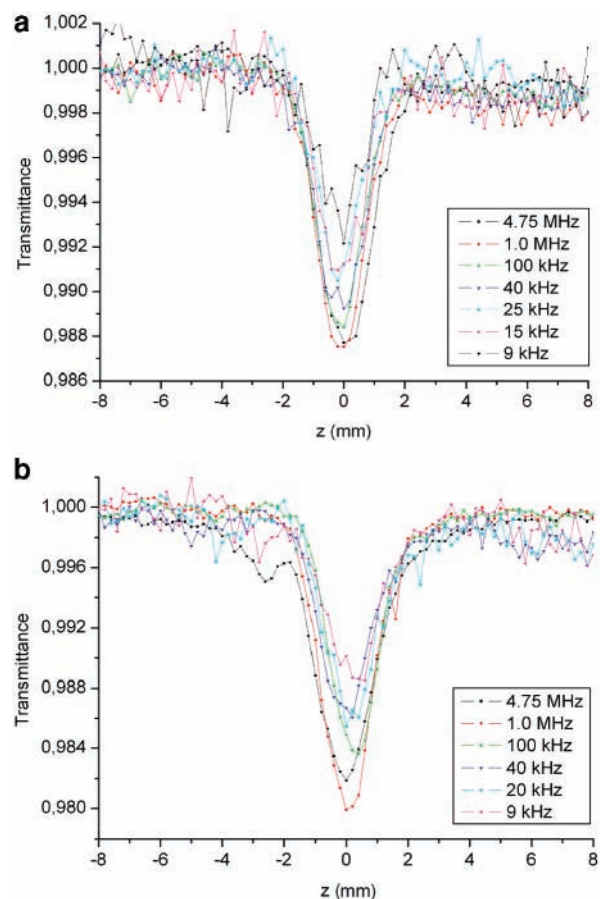

**Figure 6.** Representative z-scan measurements at 740 nm for various pulse repetition frequencies: (a) ATP1; (b) Pt1-G1.

relative quantum yield of the different samples.<sup>18,19</sup> Measurements were performed using Coumarin 110 as a reference (results not shown). The relative fluorescence quantum efficiency (QE) of Coumarin 110 was measured against quinine sulfate (QS) and found to be 1.10, giving an absolute QE of 0.60 if the QE of QS is taken to be 0.546.<sup>31,32</sup> The QE results of ATP1, ATP2, Pt1-G1 and Pt1 are all given in Table 1.

**3.2. TPA Using Femtosecond Z-scan.** Femtosecond z-scans were performed using the Ti:Sapphire laser at 740 nm with pulse lengths of approximately 180 fs. The pulse repetition frequency was possible to change between 4.75 MHz and 9 kHz. Representative z-scan traces for various prf for ATP1 and Pt1-G1 are shown in Figure 6, both showing the typical tendency of decreasing response with reduced prf.

Analyzing curves in Figure 6 to find the TPA cross section from eq 2 yields results shown in Figure 7 when data are plotted as a function of the pulse repetition frequency. At high prf, ATP1 seems to have approximately the same TPA cross section as Pt1-G1 around 15–16 GM. ATP2 has a somewhat lower TPA cross section around 9–10 GM. The nonlinear absorption at high prf is assumed not to be entirely pure TPA, but to have some contributions from ESA. In Figure 7, a characteristic change in the apparent TPA cross section at lower pulse frequencies is observed (below approximately 100 kHz), where the nonlinear absorption is assumed to approach a more pure simultaneous TPA cross section. Some representative numerical values at different prf are given in Table 1.

**3.3. Two-Photon Excited Luminescence.** At low concentration, one- and two-photon excited (TPE) luminescence measurements were performed at 1.0 MHz pulse repetition frequency. The one-photon luminescence spectra of ATP1, ATP2 and Pt1-

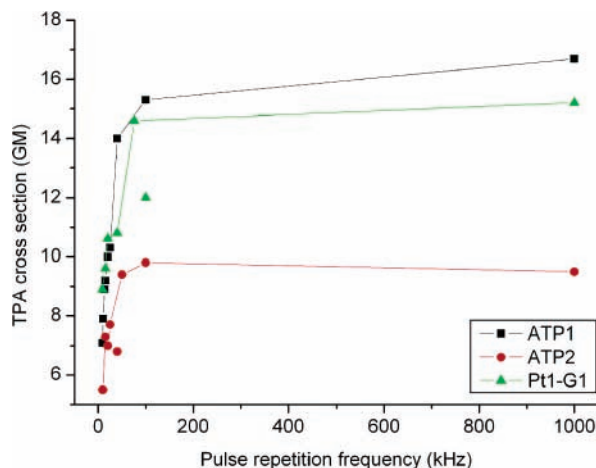

**Figure 7.** TPA cross-section of ATP1 (squares), ATP2 (dots) and Pt1-G1 (triangles) determined from femtosecond z-scan measurements at different pulse repetition frequencies.

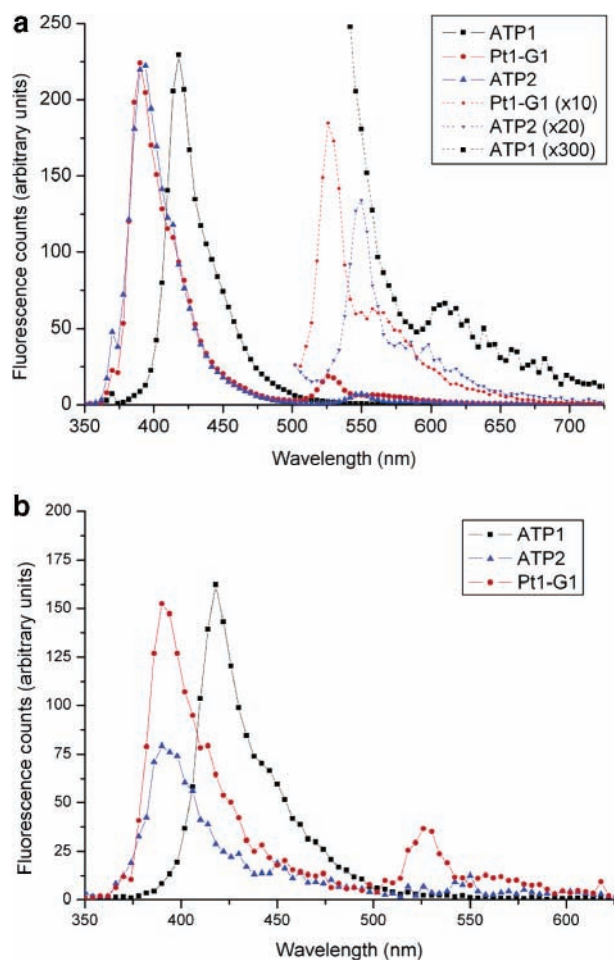

**Figure 8.** (a) Single and (b) two-photon induced luminescence excited at 370 and 740 nm from approximately  $20 \mu\text{M}$  samples at 1 MHz prf. The plots show the fluorescence peaks around 400–450 nm and weak phosphorescence peaks above 500 nm. Data above 500 nm in (a) are multiplied with a scale factor to be clearly seen.

G1 are shown in Figure 8a (excited at 370 nm), where the large fluorescence peaks at 390 nm (Pt1-G1, ATP2) and 420 nm (ATP1) are observed. Because the phosphorescence here is weak, because of quenching by solvent oxygen, data above 500 nm are shown multiplied with a scale factor.

Two-photon absorption induced luminescence spectra are shown in Figure 8b. The excitation wavelength was 740 nm. A

different relative amount of luminescence in the fluorescence bands, compared to the one-photon case, was observed. Because the concentration in each sample is the same, the TPA properties must be quantitatively different from that in the case of one-photon excitation for these compounds. The emission peaks were not shifted compared to the one-photon case, supporting the idea that internal conversion results in the same emission independent of the excitation method. The analysis of the spectra in Figure 8b, following eq 1 above, shows the ratio between the TPA cross sections of C110 and Pt1-G1 to be 0.3 at 1 MHz prf. From the z-scan data in Table 1 the ratio between the cross sections found for C110 and Pt1-G1 yields a value of approximately 0.45. The ATP1 and ATP2 compounds also showed a similar behavior with the TPA cross section to be in the correct order of magnitude compared to C110. The same qualitative behavior and order of magnitudes for the TPA cross sections was also observed at 720 nm excitation wavelength.

## 4. Discussion

**4.1. Photophysical Properties.** The TPA cross section determined from z-scan measurements presented above, are assumed to approach pure simultaneous TPA cross sections when the pulse repetition frequency goes to zero because then it should be no contributions from ESA of the triplet levels. Because of the relatively long phosphorescence lifetimes at 200–500 ns, the pulse repetition frequency must be below at least 500 kHz and should approach 100 kHz, before one can assume that all excited molecules have relaxed to the ground state before the next pulse strikes the sample. Above approximately 100 kHz, a fraction of the molecules may still be excited in a triplet state, and triplet absorption from that state may give a significant contribution to the total nonlinear absorption. Figure 7 shows that the apparent TPA cross sections are reduced below 100 kHz, and the values reported at 9 kHz were assumed to approach, and to be close to, the correct TPA cross sections.

The TPA cross section of the C110 reference material was measured using the z-scan technique at 1 MHz. The TPE luminescence measurements of Pt1-G1, ATP1 and ATP2 should in principle give the same results of the TPA cross sections as from the z-scan measurements. However, the fluorescence results are found to differ from the z-scan results. The results are found to differ as much as up to 30%. Based on the common root-mean-square (rms) error analysis, the relative error of the TPA cross sections from the two methods can be estimated. In the z-scan measurement the uncertainty is found to be up to 35%, where a large contribution arises from the uncertainty in the low, and noisy, TPA signal in Figure 6. The error in the quantum efficiency measurements are found to be approximately 10%, an uncertainty that enters into the calculation of the TPA cross section from the fluorescence measurements. The latter was found to have a total uncertainty of approximately 15–20%. Therefore, there is no surprise that the z-scan numerical values differ from the fluorescence data. Both results are found to be consistent, and in the same order of magnitude, and are comparable within experimental error limits.

With regard to the two-photon properties, the absorption cross sections found in this study also are in agreement with our previous reported results on the capped and uncapped Pt-acetylides.<sup>14,15</sup> However, our reported values are (as discussed in ref 14 and 15) much smaller than the previous values reported by McKay et al. for the uncapped Pt1-compound (236 GM at 595–640 nm).<sup>7,9</sup> Here they used pulses of 27 ps duration (FW1/eM) as the excitation source.<sup>9</sup> Because of the intersystem crossing

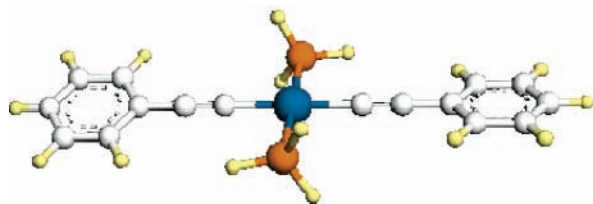

**Figure 9.** Geometry optimized structure of the  $\text{Pt}(\text{PH}_3)_2(\text{ethynylbenzene})_2$  molecule, showing a nonplanar structure with the two benzene rings.

rate must be very high to compete with the measured fluorescence decay time, it is possible that ESA contributes to the apparent TPA cross section in their measurements.<sup>7,9</sup>

The phosphorescence and fluorescence data reported here for the ATP1 and ATP2 compound, and new repeated measurements on Pt1-G1, are in good agreement with the results of both Staromlynska<sup>9</sup> and McKay<sup>5</sup> on the uncoated Pt–ethynyl compound and with our previous results from Vestberg<sup>15</sup> and Lindgren<sup>16</sup> on the dendron coated Pt–acetylides. Staromlynska and McKay report a lifetime of 330 ps for the fluorescence band, and approximately 500 ns for the phosphorescence band. This corresponds well to the results for the smallest coated Pt samples. The ATP1 and ATP2 compounds are in this study not found to differ significantly from the other Pt compounds, with respect to fluorescence and phosphorescence properties.

**4.2. Electronic Structure and Excited States.** To assign the electronic states participating in the photophysics, we examined the molecules with calculations using time-dependent (TD) density functional theory (DFT).<sup>33</sup> Some simplifications were made to reduce the computational time: instead of tributylphosphine groups, smaller  $\text{PH}_3$  groups were used, and the terminal  $\text{C}_5\text{H}_{11}$  and acetylide groups were replaced by hydrogen atoms. This is reasonable, because the eliminated groups do not participate in any important  $\pi$ -conjugation and have only minor influence on the UV–vis spectral properties. Geometry optimization was calculated for two starting isomers: (A) with the P–Pt–P axis (y) in the same plane (yz) as the phenyl rings; (B) with the P–Pt–P axis being perpendicular to the plane (xz) of the phenyl rings. TD DFT calculations with B3LYP functional<sup>33</sup> and LANL2DZ basis set<sup>34</sup> was found to give rather different UV–vis absorption spectra for these two choices; the (A) isomer was found to have lower excited-state energies by about 1 eV in comparison with the (B) isomer. Specifically, for the  $\text{Pt}(\text{PH}_3)_2(\text{ethynylbenzene})_2$  molecule in the form of the (A) isomer the intense  $\pi\pi^*$  absorption band is predicted to be at 372 nm (3.33 eV), but for the (B) isomer it was calculated to 284 nm (4.36 eV). In both cases this is not the first excited singlet state; there are a few lower states of  $^1\sigma\pi^*$  type. Geometry optimization without symmetry restrictions provides some intermediate nonplanar structure as shown in Figure 9; in this case B3LYP/LANL2DZ calculation predicts the intense  $\pi\pi^*$  absorption band at 332 nm (3.73 eV) in close agreement with observations (328 nm<sup>35</sup>).

For the Pt1 model, the result for the intense  $\pi\pi^*$  absorption band was 404 nm for the (A) isomer. At the optimized nonlinear and nonplanar geometry the intense  $\pi\pi^*$  band shifted to 353 nm, in better agreement with previous experimental data (355 nm<sup>36</sup>) and our own measurements of the Pt1-G1 dendrimer (Table 1). The calculated spectra of all (A) isomers are closer to experiment; the intense one-photon transition occurs only along z-axis (direction of the triple bond). The details of the calculated geometries, other transition energies and triplet absorption properties of the Pt1 model are found in Minaev et al.<sup>37</sup>

The TPA cross section was calculated using the same TD DFT method from the residue of the quadratic response function using the Dalton code.<sup>38</sup> Here, the Stuttgart SDD basis set with the effective core potential was used.<sup>39</sup> The planar (A) isomer was used to simulate the Pt1-G1 two-photon absorption to take advantage of the  $C_{2v}$  symmetry point group. From the theory of TPA transition probability tensor (S)<sup>40</sup> the large TPA correspond only to the  $S_{zy}$  and  $S_{zx}$  matrix elements of this tensor and to weak one-photon transition from the totally symmetric  $^1A_1$  ground state to the  $^1B_2$  and  $^1B_1$  states, respectively. These states are not shown in normal absorption and emission spectra but are very important for spin–orbit coupling effects and photophysical properties of platinum acetylides.<sup>16</sup> For example, strong phosphorescence of the studied molecules borrows intensity from the triplet–triplet  $^3A_1$ – $^3B_2$  and  $^3A_1$ – $^3B_1$  transitions and acquires polarization perpendicular to the long molecular axis (z-axis).<sup>16</sup> The lowest  $^1B_2$  state was found to yield the largest contribution to TPA. The maximum TPA probability for the Pt1-G1 molecule occurs at rather short wavelength (604 nm); the calculated TPA cross section was found to be  $\sigma_2 = 34.5$  GM. For the simplified model of the ATP2 molecule  $\sigma_2 = 16.1$  GM was obtained at a maximum wavelength corresponding to 698 nm, which is close to the laser wavelength (740 nm) used in our TPA measurements. DFT results for a number of Pt–acetylide molecules were in good agreement with the calculated one- and two-photon absorption spectra obtained by random phase approximation.<sup>40</sup> It is emphasized that although these theoretical results are obtained for simplified models of the studied molecules, with regard both to symmetry constraints and to the simplified substitutions, they are in qualitative agreement with our experimental two-photon absorption cross-section results. Further systematic theoretical investigations of the thiophene substituted Pt–acetylides will appear elsewhere.<sup>41</sup>

## 5. Summary and Conclusions

Two-photon absorption and luminescence properties of the compounds abbreviated ATP1 and ATP2 have been studied and compared to those of the previously studied Pt1-G1. Linear and two-photon excited spectra of the two former are similar to those of Pt1-G1, but with a red shift in the fluorescence band for the ATP2 compound. However, in both thiophenyl samples the phosphorescence bands were red-shifted. Two-photon excited emission spectra were all similar to the one-photon spectra. The formation of long-lived triplet states makes it especially difficult to discriminate between the different multiphoton excitation processes useful for, e.g., OPL-applications. TPA z-scan measurements using a low pulse-repetition rate show TPA cross sections of approximately 7 GM, 5 GM and 9 GM for ATP1, ATP2 and Pt1-G1, respectively. The corresponding values from high repetition rate measurements were somewhat higher. This is most likely due to contributions from triplet excited-state absorption because of the relatively long phosphorescence lifetime of some hundred nanoseconds. Our results in terms of TPA cross sections at low prf are considerably smaller than the values previously reported by McKay et al. for the uncapped Pt1-compound<sup>7</sup> using picosecond pulses for excitation. Thus, our results can give new physical insight to the efficiency of various multiphoton excitation schemes of these and related compounds. Fluorescence lifetimes were extremely short, explained by very large and efficient intersystem crossing to the triplet manifold together with oxygen quenching with the solvent.

Preliminary theoretical TD DFT calculations using simplified models for Pt1-G1 and ATP2 show good agreement with

experimental data with respect to the absorption wavelength at approximately 350 nm, the broadband TPA characteristics around 700 nm and the TPA cross sections on the order of 5–10 GM.

**Acknowledgment.** This work has been supported by the “Swedish Defence Nano Technology Programme” managed by the Swedish Defence Research Agency (FOI) ([www.nanotek.se](http://www.nanotek.se)). M.L. also acknowledges a grant from the Norwegian Research Council within the NanoMat program (Contract #163529/s10).

## References and Notes

- (1) Cifuentes, M. P.; Humphrey, M. G. *J. Organomet. Chem.* **2004**, *689* (24), 3968.
- (2) Powell, C. E.; Humphrey, M. G. *Coord. Chem. Rev.* **2004**, *248* (7–8), 725.
- (3) Vlcek, A., Jr. *Coord. Chem. Rev.* **2000**, *200–202*, 933.
- (4) Sun, S.-S.; Lees, A. J. *Coord. Chem. Rev.* **2002**, *230* (1–2), 171.
- (5) McKay, T. J.; Bolger, J. A.; Staromlynska, J.; Davy, J. R. *J. Chem. Phys.* **1998**, *108* (13), 5537.
- (6) McKay, T. J.; Staromlynska, J.; Davy, J. R.; Bolger, J. A. *J. Opt. Soc. Am. B* **2001**, *18*, 358.
- (7) McKay, T. J.; Staromlynska, J.; Wilson, P.; Davy, J. R. *Appl. Phys.* **1999**, *85*, 1337.
- (8) Staromlynska, J.; Chapple, P. B.; Davy, J. R.; McKay, T. J. *Proc. SPIE* **1994**, *2229*, 59.
- (9) Staromlynska, J.; McKay, T. J.; Bolger, J. A.; Davy, J. R. *J. Opt. Soc. Am. B* **1998**, *15* (6), 1731.
- (10) Staromlynska, J.; McKay, T. J.; Wilson, P. *J. Appl. Phys.* **2000**, *88* (4), 1726.
- (11) Vestberg, R.; Malmström, E.; Eriksson, A.; Lopes, C.; Lindgren, M. *Proc. SPIE* **2004**, *5621*, 31.
- (12) Sonogashira, K.; Fujikura, Y.; Yatake, T.; Toyoshima, N.; Takahashi, S.; Hagihara, N. *J. Organomet. Chem.* **1978**, *145*, 101.
- (13) Hagihara, N.; Sonogashira, K.; Takahashi, S. *Adv. Polym. Sci.* **1981**, *41*, 149.
- (14) Glimsdal, E.; Eriksson, A.; Vestberg, R.; Malmström, E.; Lindgren, M. *Proc. SPIE* **2005**, *5934*, 59340N.
- (15) Vestberg, R.; Westlund, R.; Eriksson, A.; Lopes, C.; Carlsson, M.; Eliasson, B.; Glimsdal, E.; Lindgren, M.; Malmström, E. *Macromolecules* **2006**, *39*, 2238.
- (16) Lindgren, M.; Minaev, B.; Glimsdal, E.; Vestberg, R.; Westlund, R.; Malmström, E. *J. Lumin.* **2007**, *124* (2), 302.
- (17) Lind, P.; Boström, D.; Carlsson, M.; Glimsdal, E.; Lindgren, M.; Lopes, C.; Eliasson, B. Structure and Nonlinear Optical Properties of trans-Bis(arylalkynyl) Platinum (II) Complexes with Phenyl and Thiophenyl Groups. Submitted to *J. Phys. Chem. A*.
- (18) Williams, A. T. R.; Winfield, S. A.; Miller, J. N. *Analyst* **1983**, *108*, 1067.
- (19) *A Guide to Recording Fluorescence Quantum Yields*, HORIBA Jobin Yvon Inc. <http://www.jobinyvon.com/usadivisions/fluorescence/applications/quantumyieldstrad.pdf>.
- (20) Xu, C.; Webb, W. W. *Multiphoton Excitation of Molecular Fluorophores and Nonlinear Laser Microscopy*; Lakowicz, Joseph R., Ed.; Topics in Fluorescence Spectroscopy Vol. 5; Plenum Press: New York, 1997; Chapter 11, pp 471–537.
- (21) Xu, C.; Webb, W. W. *J. Opt. Soc. Am. B* **1996**, *13* (3), 481.
- (22) Albota, M. A.; Xu, C.; Webb, W. W. *Appl. Opt.* **1998**, *37* (31), 7352.
- (23) Sheik-Bahae, M.; Said, A. A.; Van Stryland, E. W. *Opt. Lett.* **1989**, *14*, 955.
- (24) Sheik-Bahae, M.; Said, A. A.; Wei, T.; Hagan, D. J.; Van Stryland, E. W. *IEEE J. Quant. Electron.* **1990**, *26*, 760.
- (25) Glimsdal, E. Master Thesis. Norwegian University of Science and Technology, 2005.
- (26) Hermann, J. A.; Baubner, T.; McKay, T. J.; Wilson, P. J.; Staromlynska, J.; Eriksson, A.; Lindgren, M.; Svensson, S. *J. Nonlin. Opt. Phys. Mater.* **1999**, *8*, 235.
- (27) Eriksson, A.; Lindgren, M.; Svensson, S.; Arntsen, P.-O. *J. Opt. Soc. Am. B* **1998**, *15*, 810.
- (28) Eriksson, A.; Lindgren, M.; Svensson, A.; Arntsen, P.-O. *Opt. Mater.* **1998**, *9*, 342.
- (29) Eriksson, A.; Lindgren, M.; Svensson, S.; Baubner, T.; McKay, T. J.; Staromlynska, J. *SPIE* **1998**, *3472*, 144.
- (30) Eriksson, A.; Bertilsson, K.; Lindgren, M. *Synth. Met.* **2002**, *127*, 147.
- (31) Demas, J. N.; Crosby, G. A. *J. Phys. Chem.* **1971**, *75*, 991.
- (32) Eaton, D. F. *Pure Appl. Chem.* **1988**, *60*, 1107.
- (33) Frish, M. J. et al. *Gaussian 03*; Gaussian Inc.: Pittsburg, PA, 2003.
- (34) Hay, P. J.; Wadt, W. R. *J. Chem. Phys.* **1985**, *82*, 299.
- (35) Masai, H.; Sonogashira, K.; Hagihara, N. *Bull. Chem. Soc. Jpn.* **1971**, *44*, 2226.
- (36) Rogers, J. E.; Hall, B. C.; Hufnagel, D. C.; Slagle, J. E.; Ault, A. P.; McLean, D. G.; Fleitz, P. A.; Cooper, T. M. *J. Chem. Phys.* **2005**, *122*, 214708.
- (37) Minaev, B.; Jansson, E.; Lindgren, M. *J. Chem. Phys.* **2006**, *125*, 094306.
- (38) DALTON, a molecular electronic structure program, Release 2.0, <http://kjemi.uio.no/software/dalton/dalton.html>.
- (39) Andrae, M.; Haeussermann, U.; Dolg, M.; Stoll, H.; Preuss, H. *Theor. Chem. Acta* **1990**, *77*, 123.
- (40) Norman, P.; Cronstrand, P.; Ericsson, J. *Chem. Phys.* **2002**, *285*, 207.
- (41) Glimsdal, E.; Minaev, B.; et al. Manuscript in preparation.