

Mechanism of Ion Movement in AgCl and AgBr

A. K. SHUKLA, S. RAMDAS, AND C. N. R. RAO*

Department of Chemistry, Indian Institute of Technology, Kanpur 16, India

Received January 22, 1973

The following mechanisms for ion movement in AgCl and AgBr have been studied: direct vacancy migration, direct interstitial migration and collinear as well as noncollinear jumps of interstitial ions. For the last two processes, we have carried out a path-variation study. The activation energies are high (>1.0 eV) for all the migration mechanisms considered here except for the collinear jump which has an activation energy around 0.6 eV. For both the collinear and noncollinear jumps, the paths of migration have been worked out.

I. Introduction

Most of the theoretical calculations on the energies of formation and migration of point defects reported in the literature are on alkali halides. One of the important systems where detailed studies are necessary is the silver halides where cationic Frenkel defects are the dominant type of intrinsic disorder. Comparison of the ionic conductivity and self-diffusion data in pure and Cd-doped samples has shown that the Ag^+ interstitials may migrate by interstitialcy as well as by direct interstitial mechanism (I). In the direct interstitial mechanism, the ion migrates by pushing directly through a cube-face or a cube-edge to a new interstitial position (see Fig. 1a). In the interstitialcy mechanism, the Ag^+ ion present interstitially at the centre of an elementary cube, migrates by pushing one of the four neighbouring Ag^+ ions off its lattice site into a new cube center position and itself taking the normal lattice site so vacated (Fig. 1b, 1c and 1d). In AgCl, the displacements of the two ions can be collinear or noncollinear [making an angle of $\cos^{-1}(1/3)$ with each other]. Consequently, the observed activation energy would be a mean value of the energies for the two processes. Thus, it becomes obvious that without detailed theoretical studies on the various mechanisms of ion movement, it is difficult to pinpoint the most probable mechanism(s) for ion migration in silver halides.

Hove (2) has carried out some calculations on the interstitialcy migration in AgCl by finding the stable position of the migrating ion with respect to several locations of the other ion. He finds a

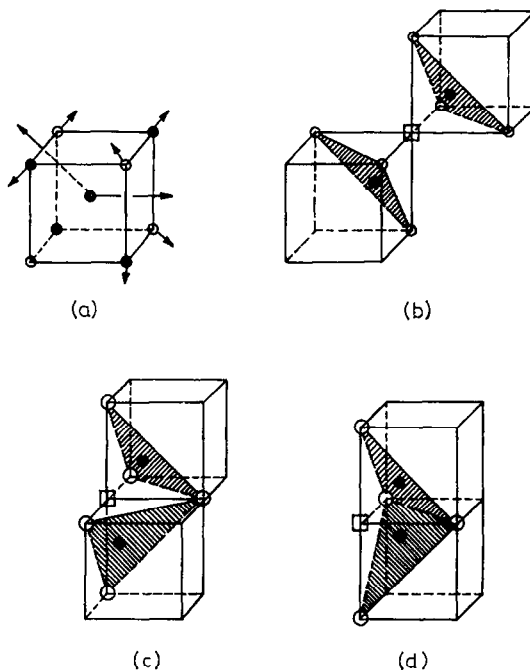

FIG. 1. (a) Direct interstitial migration through the cube face as well as the cube edge; (b) symmetric dumb-bell configuration for collinear interstitialcy migration; (c) noncollinear interstitialcy migration across a common cube edge; (d) noncollinear interstitialcy migration across a common cube face.

* To whom all correspondence should be addressed.

minimum for the configuration in which one of the ions is at 0.577 and the other at 0.346 distances (normalized to the interionic distance, r_0) apart from the vacancy in the case of non-collinear motion, the activation energy for this process being 0.8 eV. In the collinear motion, Hove reports a near-zero activation energy for the configuration in which both the ions are symmetrically placed at a distance of 0.346 from the vacant site. The experimentally reported mean value of the activation energy (3, 4) is 0.15 eV. In the evaluation of the relaxation energy, Hove considers only the two moving ions and the immediately surrounding 6 Cl^- ions. Unfortunately, no details of these calculations are available for a critical assessment of the formulation and choice of potentials.

We have presently evaluated formation and migration energies of defects in AgCl and AgBr by adopting a procedure analogous to that of Tosi and Doyama (5) combined with a more elaborate treatment of the relaxations of ions and employing literature values of the polarizabilities (6) and compressibilities (7). The problems examined by us are the following: (1) formation of isolated Frenkel and Schottky defects, (2) direct vacancy migration, (3) direct interstitial migration through the cube face as well as the cube edge, and (4) non-collinear and collinear migration with path variation along the lines studied by Hove (2).

II. Method of Calculation

As in the Mott and Littleton (8) procedure, we divide the crystal into region I and region II. In region I, the relaxations and moments, ξ_k and m_k of the ions immediately surrounding the defects are treated as unknowns while in region II, the displacement and moments of rest of the positive and negative ions are described by M' and M'_\perp in the quasi-continuum model (1, 8). The values of ξ_k and m_k are obtained by minimizing the total relaxation energy, U_{relax} by the optimization procedure of Rosenbrock (9). The value corresponding to the equilibrium displacements was added to the energy of the rigid lattice containing defects (U_r) to obtain the total defect configuration energy. Detailed description of the formulation and the procedure have been published elsewhere (10).

In the treatment of the relaxations of region I ions, the electrostatic forces acting on any one ion from all the defects have been considered without any *a priori* assumption. In some of the saddle

point configurations, the directions of ξ_k and m_k were fixed considering the relative magnitudes of both electrostatic and overlap interactions with the migrating ion. Thus, in the collinear migration, when the migrating ion is at $(-0.3, -0.3, -0.3)$ position, it is almost in plane with three of the oppositely charged Cl^- ions. In this configuration, overlap forces dominate over the attractive Coulomb forces with the result that the Cl^- ions move away from the migrating ion. In the computer programme developed by us, the right direction of the displacement is automatically assumed depending on the magnitude of the two forces in the rigid lattice configuration.

The short-range overlap interactions were computed following the modified Born-Mayer potentials (11) given by the expression,

$$\phi_{ij}(r_{ij}) = \beta_{ij} b \exp[(r_i + r_j - r_{ij} r_0)/\rho] - c_{ij}/(r_0 r_{ij})^6 - d_{ij}/(r_0 r_{ij})^8 \quad (1)$$

Here, β_{ij} is Pauling's coefficient, c_{ij} and d_{ij} are the van der Waals constants for the dipole-dipole and dipole-quadrupole interactions, r_i and r_j are the ionic radii of the respective ions while b and ρ are the overlap repulsion constants. The quantities b and ρ were derived from the equation of state and its volume derivative assuming Mayer's values (7) for the van der Waals coefficients in the lattice energy expressions. The interionic distances, compressibilities and the values of b and ρ thus obtained are listed below:

	AgCl	AgBr
r_0 (Å)	2.772	2.884
β (10^{-12} dyne $^{-1}$ cm 2)	2.40	2.75
b (10^{-12} ergs/mol)	1.3635	1.3041
ρ (Å)	0.245	0.252

In Eq. (1) we have used 1.2 Å for the radius of the Ag^+ ion as reported by Abbink and Martin (12). We have ensured that use of 1.1 Å for Ag^+ radius as dictated by the Cl^- radius of Tosi (11) does not significantly alter the results on defect energies; in fact, the formation energies are better with 1.2 Å.

Many workers have suggested increased van der Waals interaction terms compared to Mayer's values for silver and cesium halides. In the early work, this was taken care of by introducing an arbitrary multiplication constant for the van der Waals contribution in the lattice energy expressions (13). Recently reported van der Waals coefficients of Lynch (14) also support this view. However, on substituting Lynch's values, we find a large positive deviation from the experimentally

TABLE I
FORMATION ENERGIES OF SCHOTTKY AND
FRENKEL DEFECTS

	AgCl		AgBr	
	Schottky ^a	Cation ^b Frenkel	Schottky ^a	Cation ^b Frenkel
ξ	0.065	0.116	0.059	0.097
	0.071	0.001	0.072	0.001
m	-0.061	-0.050	-0.079	-0.051
	0.049	0.091	0.045	0.110
U_{relax}	-3.728	-4.904	-3.731	-4.793
	-3.675		-3.551	
U_{ri}	9.014	1.093	8.710	0.994
	9.088		8.858	
U_v^{\pm} (or U_i)	5.286	-3.811	4.979	-3.798
	5.413		5.307	
E_s (or E_f) ^c	1.65	1.48 ^d	1.50	1.18 ^e

^a The values in upper and lower rows correspond to cation anion vacancies, respectively.

^b Top row values for the relaxation parameter correspond to the outward movement of the positive ions while the bottom row values denote the inward relaxation of the negative ions towards the interstitial.

^c $E_s = U_v^+ - \frac{1}{2}U_{r1}^+ + U_v^- - \frac{1}{2}U_{r1}^-$; $E_f = U_v^+ + U_i$.

^d Experimental values: Abbink and Martin (16), 1.44 eV; Muller (17), 1.24 eV; Corish and Jacobs (18), 1.47–1.52 eV.

^e Experimental value of Muller (17) = 1.06 eV.

computed lattice energies; further, these coefficients give unreliable results of the defect formation energies.

III. Results and Discussion

The results of our calculations on the formation energies of Schottky and Frenkel defects (E_s and E_f) are shown in Table I. The energies of the saddle point configurations for direct vacancy as well as interstitial migration are listed in Table II. In the path variation study for non-collinear and collinear jump mechanisms, we assume that the ion migrates in a straight path from the cube center to a lattice point and vice versa. To do this, we keep one of the migrating ions at a fixed position (y, y, y) , and compute the energies of the configurations at different locations $(\pm x, -x, -x)$ of the other ion; this is repeated for various positions of the first ion. The results of such calculations are shown in Fig. 2. In Tables III and IV we have listed the corresponding energies for the most stable configurations in the noncollinear and collinear jump processes. The relaxations and moments listed in Tables I–IV are in units of r_o and e_r_o respectively and the energies are in eV.

Formation Energies of Defects

Unlike the earlier theoretical estimates of Kurosowa (15), the formation energies calculated by us (Table I) predict the predominance of Frenkel defects in AgCl and AgBr and there is good agreement with the experimental values reported by Abbink and Martin (16), Muller (17) as well as Corish and Jacobs (18). Success of the present calculations may partly be due to the adequate representation of the short-range interactions. With the explicit inclusion of elastic

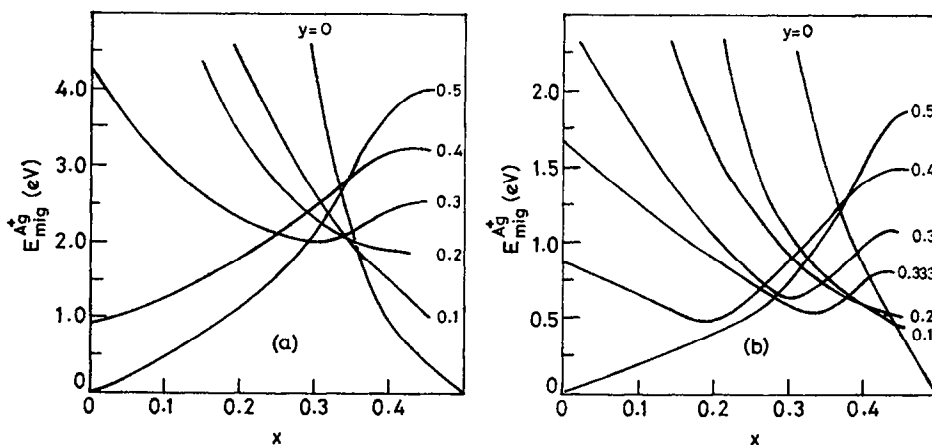

FIG. 2. Migration energy profiles for (a) the noncollinear interstitialcy migration mechanism and (b) the collinear interstitialcy migration mechanism for different paths.

TABLE II
 DIRECT VACANCY AND INTERSTITIAL MIGRATION ENERGIES

		AgCl		AgBr		
		Vacancy ^a	Cation ^b interstitial	Vacancy ^a	Cation ^b interstitial	
ξ_1	(-100)	0.059 0.065	0.115	(-100)	0.055 0.064	0.111
ξ_2	(100)	0.141 0.140	0.161	(100)	0.129 0.134	0.151
ξ_3	(00-1)	0.028 0.034		(00-1)	0.007 0.030	
m_1	(-100)	0.057 0.047	-0.108	(-100)	0.080 0.043	-0.143
m_2	(100)	-0.052 0.044	0.119	(100)	-0.074 0.049	0.108
m_3	(00-1)	-0.039 0.030		(00-1)	-0.051 0.032	
U_{relax}		-6.315 -6.283	-8.656		-6.294 -6.111	-8.266
U_{sp}		6.324 6.498	-2.640		5.969 6.437	-2.674
E_m^c		1.04 1.09	1.17		0.99 1.13	1.12

^a The values in upper and lower rows correspond to cation and anion vacancies, respectively.

^b ξ_1 , m_1 and ξ_2 , m_2 are the equilibrium values for the negative and positive ions in the saddle point configuration, both the relaxations are outwards. Relaxations of all the region I ions are not included in this table.

^c We denote cation or anion vacancy migration energies by $E_m^{v(\pm)}$ and the interstitial migration energy by E_m^i . These values were obtained from $E_m^{v(\pm)} = U_{sp}^{v(\pm)} - U_v^{\pm}$ and $E_m^i = U_{sp}^i - U_i$.

distortion terms,¹ the E_s values may increase slightly (by ~ 0.2 eV) whereas no such increment in E_f is expected because of the negligible volume of the interstitial defect.

Vacancy Migration

When Frenkel defects are formed, there are equal number of interstitials and cation vacancies, but the concentration of the latter is further supplemented by the formation of Schottky defects at high temperatures. A distinct possibility of vacancy movement in AgCl and AgBr is

¹ In our polarization treatment, we do take into account the "quasi-elastic" formation energy of the dipoles. The formulation used by us has been found to be quite successful in the case of alkali halides (10). We believe that the present results are reliable and uncertainties, if any, can only be due to the inadequacy of the short-range potentials.

indicated by the activation energies (Table II). The barrier height is ~ 1.0 eV for both cation and anion vacancy migration. There is some support for our results from the recent diffusion studies on pure and Cd-doped AgCl by Sawyer and Laskar (19) who estimate an activation energy of 1.3 eV for this mechanism; the energies for vacancy migration in alkali halides are also in this range (1). However, most other experimental values for vacancy migration are in the range 0.27-0.35 eV (18). If we take the large barrier height of ~ 1 eV for vacancy migration to be correct, it cannot account for the high conductivity of AgCl and AgBr at low temperatures; vacancy migration, if at all, would become important in the intrinsic region (12).

Interstitial Migration

We find that direct cation interstitial migration through the cube face is associated with activation

TABLE III
PARAMETERS FOR THE STABLE CONFIGURATION
IN THE NONCOLLINEAR INTERSTITIALCY
MIGRATION^a

	AgCl	AgBr
ξ_1 (100)	0.058	0.040
ξ_2 (010)	0.039	0.044
ξ_3 (-100)	0.039	0.042
ξ_4 (0-10)	0.052	0.046
m_1 (100)	-0.123	-0.272
m_2 (010)	-0.109	-0.106
m_3 (-100)	-0.053	-0.064
m_4 (0-10)	-0.093	-0.106
U_{relax}	-4.234	-4.384
U_{sp}^i	-1.785	-2.048
E_m^i (NC)	2.02	1.75

^a In this configuration one of the two migrating ions is at (0.33, 0.33, 0.33) and the other at (0.3, -0.3, -0.3). Relaxations of only four of the important ions in region I are listed here.

energies similar to those obtained for cation vacancy migration (Table II). The change in slope found in the conductivity data at high temperature could, therefore, arise from a direct interstitial mechanism as well. Systematic diffusion and ionic conductivity studies as a function of dopant concentration would be necessary to clarify this situation. Earlier workers completely neglected the possibility of direct interstitial migration on theoretical grounds because of the crowding of the anions and the migrating ion in the cube face. Hove (2) has reported ~3.0 eV for the activation energy for this mechanism. We, however, obtain a similar value (~2.9 eV) only in the case of direct interstitial migration through the cube-edge. Since the overlap repulsion between the migrating cation with the nearby anions as well as cations predominate over the electrostatic interactions, all the four ions in the cube face relax outwards in the (100) plane; this allows an easier passage for the cation to move to an adjacent cell.

Interstitialcy Migration

Contrary to earlier expectations (2-4), we find no evidence for noncollinear migration along cube edge in silver halides (Table III). According to the energy profiles shown in Fig. 2(a), we find a minimum energy configuration (~2.0 eV) when one of the migrating ions is at (0.3, -0.3, -0.3)

and the other is at (0.33, 0.33, 0.33).² Hove (2) obtained a minimum value of 0.8 eV for similar energy profiles when the two ions are 0.597 and 0.346 distances (in units of r_0) apart from the vacancy.

In contrast to the unsymmetrical configuration in non-collinear motion, we find minima around $x = 0.3$ when one of the two migrating ions is at ($\mp x, \mp x, \mp x$) position in the collinear mechanism (Fig. 2b). At $x = 0.3$, the migrating ion is almost in the same plane with the three Cl^- ions adjacent to the vacancy. Even for this configuration, the activation energy is about 0.6 eV which is much higher³ than the activation energy for conduction (0.1-0.2 eV) observed at low temperature (17, 18, 20). One possibility is that the ion actually moves along curved paths rather than the linear paths indicated here.

It has been suggested (21) that for ions which are closer than the nearest interionic distance, r_0 , the overlap potential must take the inverse form. It is reasonable to expect that the migrating ion will move away from the plane containing the three Cl^- ions when we employ an inverse form of the overlap potential. We find an increase in the barrier heights to migration by about 0.25-0.9 eV for all the collinear configurations with a potential of the type $\phi(r) = Br^{-12}$ (the constant B being found from the lattice energy expressions).

We have seen that the energies of ion migration through vacancies, direct interstitial, noncollinear and collinear interstitialcy mechanisms are all generally higher than the experimental values. This deviation may in part be due to the neglect of contributions from covalency in silver halides in

² Noncollinear migration across the cube face is not considered feasible; the activation energy from the resulting configuration was >3.0 eV.

³ Sawyer and Laskar (19) report a value of 0.56 eV as the activation energy for diffusion of Cd^{2+} ion in Cd-doped AgCl at low temperatures. This they attribute to interstitial motion of Cd^{2+} . If we assume this process to be due to collinear motion, we should expect higher activation energy for Ag^+ diffusion by this mechanism. Since the polarizability of Ag^+ ion is larger than that of Cd^{2+} (and also the electrostatic repulsion between Cd^{2+} and 4 Ag^+ ions will be considerable), we expect U_i for Ag^+ interstitials to be less than that for Cd^{2+} interstitials. The stable dumbbell configuration energy will be more or less similar in both the cases and the activation energy which is given by the difference will be more for Ag^+ movement than for Cd^{2+} migration by this mechanism. Since this is not so, the results of Sawyer and Laskar (19) must be interpreted in terms of some other mechanism.

TABLE IV

PARAMETERS FOR THE STABLE CONFIGURATION
IN THE COLLINEAR INTERSTITIALCY
MIGRATION

	AgCl	AgBr
ξ_1 (-100)	0.048	0.047
ξ_2 (-1-1-1)	0.090	0.090
ξ_3 (-10-1)	0.049	0.056
m_1 (-100)	-0.103	-0.068
m_2 (-1-1-1)	-0.026	-0.026
m_3 (-10-1)	0.023	0.036
U_{relax}	-4.088	-4.125
U_{sp}^i	-3.185	-3.190
F_m^i (C)	0.63	0.61

the present treatment. There is some evidence for the presence of substantial covalency in AgCl since the modified shell model fails to generate phonon dispersion curves (22). A treatment similar to that of Asano and Tomishima (23) in the case of ZnS would probably be worthwhile. It would also be desirable to examine the applicability of the super ionic conductor model of Rice and Roth (24) to AgCl and AgBr.

The plots of migration energy curves in Fig. 2(a) and (b) provide an interesting study of the paths of migration by the noncollinear and collinear interstitialcy mechanisms. In both these mechanisms, the ion initially moves along the $y = 0.5$ path and then progressively jump to paths with $y = 0.4, 0.3$ and so on.

Acknowledgment

We thank the Council of Scientific and Industrial Research (India) and the Air Force Office of Scientific Research (Grant AFOSR-71-2138) for support of this research and the staff of the IIT/K Computer Centre for providing the facilities of the IBM 7044/1401 Computers.

References

1. L. W. BARR AND A. B. LIDIARD, in *Physical Chemistry: An Advanced Treatise*, Vol. 10, ed. by H. Eyring, Academic Press, New York, 1970.
2. J. E. HOYE, *Phys. Rev.* **102**, 915 (1956).
3. M. D. WEBER AND R. J. FRIAUF, *J. Phys. Chem. Solids* **30**, 407 (1969).
4. J. P. GRACEY AND R. J. FRIAUF, *J. Phys. Chem. Solids* **30**, 421 (1969).
5. M. P. TOSI AND M. DOYAMA, *Phys. Rev.* **151**, 642 (1966).
6. J. R. TESSMAN, A. H. KAHN, AND W. SHOCKLEY, *Phys. Rev.* **93**, 890 (1953).
7. J. E. MAYER, *J. Chem. Phys.* **1**, 327 (1933).
8. N. F. MOTT AND M. J. LITTLETON, *Trans. Faraday Soc.* **34**, 485 (1938).
9. H. H. ROSEN BROCK, *Computer J.* **3**, 175 (1960).
10. (a) A. K. SHUKLA, S. RAMDAS, AND C. N. R. RAO, *J. Chem. Soc. Faraday II*, **69**, 207 (1973); (b) S. RAMDAS, A. K. SHUKLA, AND C. N. R. RAO, *Chem. Phys. Lett.* **16**, 14 (1972).
11. M. P. TOSI, *Solid State Phys.* **16**, 1 (1964).
12. H. C. ABBINK AND D. S. MARTIN, *J. Phys. Chem. Solid* **33**, 913 (1972).
13. K. J. RAO AND C. N. R. RAO, *Phys. Stat. Solidi* **28**, 157 (1968).
14. D. W. LYNCH, *J. Phys. Chem. Solids* **28**, 1941 (1966).
15. T. KUROSAWA, *J. Phys. Soc. Japan* **13**, 153 (1958).
16. H. C. ABBINK AND D. S. MARTIN, *J. Phys. Chem. Solids* **27**, 205 (1966).
17. P. MULLER, *Phys. Stat. Solidi* **12**, 775 (1965).
18. J. CORISH AND P. W. M. JACOBS, *J. Phys. Chem. Solids* **33**, 1799 (1972) and the references cited therein.
19. E. W. SAWYER AND A. L. LASKAR, *J. Phys. Chem. Solids* **33**, 1149 (1972).
20. R. J. FRIAUF, *Phys. Rev.* **105**, 843 (1957).
21. R. GUCCIONE, M. P. TOSI, AND M. ASDENTE, *J. Phys. Chem. Solids* **10**, 162 (1959).
22. P. R. VIJAYARAGHAVAN, R. M. NICKLOW, H. G. SMITH, AND M. K. WILKINSON, *Phys. Rev.* **B1**, 4819 (1970).
23. S. ASANO AND Y. TOMISHIMA, *J. Phys. Soc. Japan* **13**, 1119 (1958); *ibid.*, **13**, 1126 (1958).
24. M. J. RICE AND W. L. ROTH, *J. Solid State Chem.* **4**, 294 (1972).