

Transition Metal Iodates

I. Preparation and Characterization of the 3*d* Iodates

K. NASSAU, J. W. SHIEVER, AND B. E. PRESCOTT

Bell Laboratories, Murray Hill, New Jersey 07974

Received September 6, 1972

The transition metal iodates provide a group of compounds with centric and acentric structures and magnetic alignment at low temperature, optical absorption and emission, as well as piezoelectric, ferroelectric, and related properties, and possibilities of cross-interactions.

Many inconsistent reports on these iodates and their hydrates exist, mainly due to lack of characterization. We report the occurrence of 13 compounds: Cr(IO₃)₃; Mn(IO₃)₂; Fe(IO₃)₃; Co(IO₃)₂ and its 2 and 4 hydrates; Ni(IO₃)₂ in α and β forms, its dihydrate, and α and β tetrahydrates; Cu(IO₃)₂ and 3Cu(IO₃)₂·2H₂O (bellingerite). Some of these compounds are unstable in the presence of water but form metastably from solution. All but four of these compounds have now been prepared as single crystals and all have been characterized by differential thermal and thermogravimetric analyses, optical absorption from 35 to 33,000 cm⁻¹, and in terms of refractive indexes and related optic parameters. In Part II structural, magnetic, and some nonlinear optical properties are reported.

1. Introduction

The alkali metal iodates, α -iodic acid, and ammonium iodate tend to have acentric structures and interesting nonlinear optical properties (1, 2). Contributing to these characteristics are the unbonded pair of electrons on the iodine and the high refractive indexes. Most of these compounds show pyroelectric and piezoelectric properties, and some are ferroelectric and possibly ferroelastic. With transition metal iodates the additional occurrence of magnetic alignments at low temperatures and optical absorptions provides the possibility of a variety of interesting cross-interactions. The possible cross-interactions between ferroelasticity and other cooperative phenomenon, for example, have been discussed by Abrahams (3).

Systematic work in this century has been done on the Co and Ni iodates by Meusser in 1901 (4), on the Cu iodates by Granger and De Schulten in 1904 (5, 6), and Spencer in 1913 (7), and on Ni and Cu iodates by Martinez-Cros and Le Boucher in 1935 (8). Some other isolated reports have also appeared, but the state of confusion can be indicated by the relatively simple cobalt iodate-water system, where out of a total of

seven compounds proposed at various times (0, 1 or 1½, 2, 3, 4, 5, and 6 hydrates) we find that only three exist (0, 2, and 4).

One of the factors which has produced much confusion is the existence of metastable forms: e.g., in the cobalt system the tetrahydrate forms first and then converts to the dihydrate in the presence of water. Since essentially all of the work in these systems was performed before rapid and precise characterization of phases by X-ray diffraction and thermal analysis was available, the misinterpretations of that period have generally survived. Accordingly, the relatively few physical measurements reported on these compounds have frequently been attributed to an incorrect formula in the absence of adequate characterization. In most instances our results indicate which compound was in fact examined, and these identifications are cited in the appropriate places.

In this report we describe the preparation of the iodates of Cr, Mn, Fe, Co, Ni, and Cu and their hydrates. Simple iodates do not appear to be formed by V or Ti. Properties reported include stability regions as determined by differential thermal and thermogravimetric analysis, optical

absorptions from 35 to 33 000 cm^{-1} , and refractive indexes and related optic parameters. In another report (9) (hereafter referred to as II) the structural, magnetic, and some nonlinear optical properties are described.

The compounds covered in this work are: $\text{Cr}(\text{IO}_3)_3$; $\text{Mn}(\text{IO}_3)_2$; $\text{Fe}(\text{IO}_3)_3$; $\text{Co}(\text{IO}_3)_2$ and its 2 and 4 hydrates; $\text{Ni}(\text{IO}_3)_2$ in α and β forms, its 2 hydrate, and α and β 4 hydrates; and $\text{Cu}(\text{IO}_3)_2$ and $3\text{Cu}(\text{IO}_3)_2 \cdot 2\text{H}_2\text{O}$ (bellingerite). A number of these are unstable in the presence of water but form metastably from solutions. All but four of these compounds have now been prepared in single crystal form.

2. Experimental Methods

Precipitations were generally performed at 0°C, room temperature, and from boiling solution using HIO_3 , HIO_3 neutralized with KOH or LiOH , and $\text{Cr}(\text{NO}_3)_3 \cdot 9\text{H}_2\text{O}$, $\text{MnSO}_4 \cdot \text{H}_2\text{O}$, $\text{Fe}(\text{NO}_3)_3 \cdot 9\text{H}_2\text{O}$, $\text{CoSO}_4 \cdot 7\text{H}_2\text{O}$, $\text{Ni}(\text{NO}_3)_2 \cdot 6\text{H}_2\text{O}$ or $\text{NiCl}_2 \cdot 6\text{H}_2\text{O}$, and CuSO_4 or $\text{Cu}(\text{NO}_3)_2 \cdot 3\text{H}_2\text{O}$, all reagent grade.

Chemical analyses were performed by Galbraith Laboratories, Inc., Knoxville, TN, and Schwarzkopf Microanalytical Laboratory, Woodside, NY.

Crystallizations from the boiling water or concentrated nitric acid solutions were performed in a 2 liter apparatus as described elsewhere (10); spontaneously nucleated crystals were used as seeds in some subsequent runs to obtain larger crystals.

Differential thermal analysis (DTA) and thermogravimetric analysis (TGA) were performed on a Dupont 900 thermal analyzer. Nitrogen was used as the atmosphere and heating rates were 20°C/min for survey work and 5°C/min for accurate determinations. Transition temperatures can be determined in this way to $\pm 5^\circ\text{C}$, although the water loss and decompositions are gradual and cannot be located as precisely. Some thermal analyses were conducted under vacuum and the gaseous decomposition products examined in a Veeco SPI-10 mass spectrometer to ensure that only H_2O was lost in the low temperature dehydrations.

Optical absorption spectra were run on a Perkin-Elmer Model 421 spectrophotometer in the 4000 to 550 cm^{-1} (2.5 to 18.2 μm) region, using fluorolube mulls between NaCl disks down to 1500 cm^{-1} , and KBr pellets below this. In the region from 550 to 35 cm^{-1} (18.2 to

286 μm) a Beckman IR-11 spectrophotometer was used with Nujol mulls between polyethylene plates with a blank mull in the reference beam. In the visible and adjacent region, 33 000 to 5300 cm^{-1} (0.3 to 1.9 μm), fine powders were packed on adhesive tape for diffuse reflectance measurements in a Cary 14 spectrophotometer; BaSO_4 was used as the reflectance reference. At the lowest wavelengths in this region the instrument slits were open wide and the results are shown as broken lines in the figures. In all these regions absorptions show as valleys.

Optic constants, namely the refractive indexes, pleochroic colors, optic character, sign, and angle, were determined in a petrological microscope by the immersion technique. The optic angles were estimated by comparison with known materials.

X-Ray powder diffraction photographs were taken on 114.6 mm diameter Straumanis type Norelco camera using V filtered $\text{CrK}\alpha$ radiation. These patterns were used for identification and classification, and structural aspects are reported in II.

3. Results

The compounds prepared and examined are shown in Fig. 1 so as to demonstrate several types of relationships:

- a. the transformations with temperature in the absence of water (solid lines);
- b. the metastable transformations in the presence of water at room temperature (dotted lines);
- c. the precipitation-crystallization conditions from water or concentrated nitric acid (broken lines); and
- d. two groupings of isostructural compounds (marked* and †).

Elemental analyses (iodine and metal) were usually performed only for the anhydrous compounds. The water content of hydrates was determined from TGA analysis; mass spectroscopy confirmed that water only was being lost. An additional check used was to determine the molecular weight of the residual oxide remaining after complete decomposition at 600 to 700°C, calculated from the assumed formula of the anhydrous metal iodate. In all instances this accurately indicated the correct oxide as determined by X-ray powder diffraction on the residue.

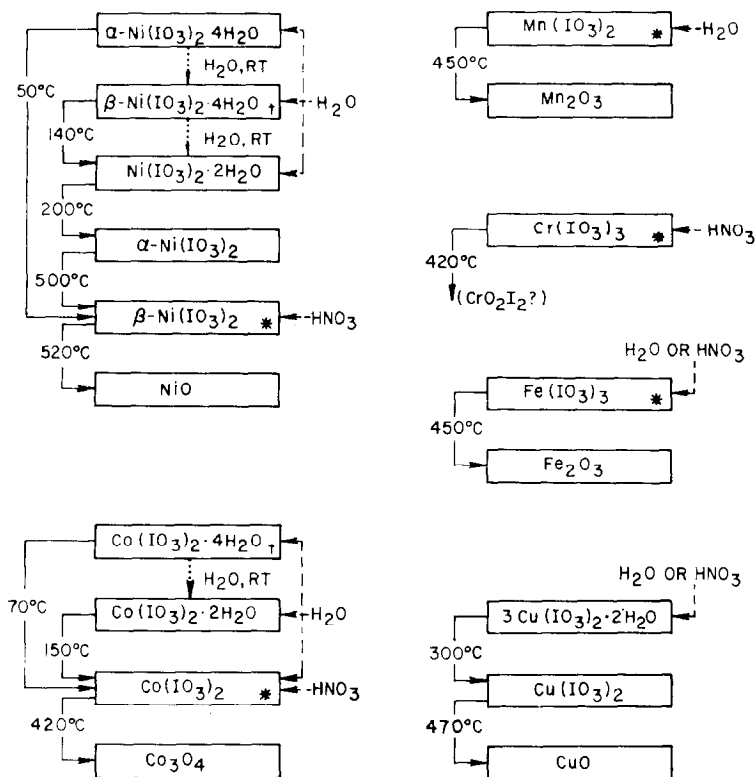

FIG. 1. Relationships among the transition metal iodates of Cr, Mn, Fe, Co, Ni, and Cu and their hydrates.

The optic parameters were in all cases consistent with the point group as determined by X-ray diffraction in II. As expected, the anhydrous compounds had the highest refractive indexes, with values decreasing as the water content increases.

In the balance of this section the preparation conditions, analytical results, and the characterization by DTA, TGA, and optic parameters are discussed. The optical absorption data are presented in Sect. 4. The structural, magnetic, and some nonlinear optical properties are reported in II.

The order of discussion is the most complicated Ni system first, followed by Co, Mn, Cr, and Fe; the less closely related Cu compounds are treated next; V and Ti do not appear to form simple iodates and are discussed last.

A. The Nickel Iodates and Their Hydrates

i. Historical

After much early confusion, including the reporting of 1, 2, 3, 4, and 6 hydrates in addition to anhydrous $\text{Ni}(\text{IO}_3)_2$, Meusser in 1901 (4)

reported the existence of one anhydride, α and β dihydrates, and a tetrahydrate. He determined solubilities and deduced that $\alpha\text{-Ni}(\text{IO}_3)_2 \cdot 2\text{H}_2\text{O}$ was stable below $\sim 75^\circ\text{C}$, the β dihydrate above 75°C , and $\text{Ni}(\text{IO}_3)_2 \cdot 4\text{H}_2\text{O}$ was unstable at all temperatures, all in the presence of water. Based on our findings described below, some of these conclusions are incorrect. We find his α dihydrate to be a second tetrahydrate, and his solubility data to be unreliable because of the metastability. We have also found a second, green, low temperature α form of the anhydride, Meusser's yellow compound being accordingly designated $\beta\text{-Ni}(\text{IO}_3)_2$. Martinez-Cros and Le Boucher (8) did note both green (produced by heating) and yellow (produced from nitric acid solution) anhydrides but gave no further characterizations.

Weigel, Imelik, and Prettre (11) observed 7.45, 4.0, and 1.775 hydrates and concluded that the latter, corresponding to a dihydrate, was the only stable compound. The indefinite water ratios of their 7.45 and 1.775 hydrates weaken their conclusions; their thermal analysis evidence for the 7.45 hydrate is poor, and we find that both

tetrahydrates are in fact stable as long as free water is not present.

The only nickel iodate compound at least partially characterized previously is $\text{Ni}(\text{IO}_3)_2 \cdot 2\text{H}_2\text{O}$ (the previously used prefix β is now redundant) which has been examined by a number of techniques: nuclear quadrupole resonance (12), infrared absorption bands (13, 14) (although the presence of water was not specified in the first of these two studies), specific heat (15), magnetic measurements (16, 17), and thermal analysis (18). The only structural data reported were the unit cell and space group determined in unpublished work by E. A. Wood as quoted by Burgiel, Jaccarino and Schalow (12) and work on the crystallographic and magnetic structures of $\text{Ni}(\text{IO}_3)_2 \cdot 2\text{D}_2\text{O}$ (19).

ii. Preparation

By the precipitation of a $\text{Ni}(\text{NO}_3)_2$ solution with a solution of HIO_3 a fluffy green precipitate, $\alpha\text{-Ni}(\text{IO}_3)_2 \cdot 4\text{H}_2\text{O}$, forms in a few hours at room temperature. In contact with the solution or with water, this will convert first to $\beta\text{-Ni}(\text{IO}_3)_2 \cdot 4\text{H}_2\text{O}$. This conversion begins immediately and goes to completion in 1 day in a laboratory well contaminated with β -tetrahydrate nuclei from previous work, but takes as long as 1 wk in a relatively "clean" laboratory. The β -tetrahydrate will now convert to $\text{Ni}(\text{IO}_3)_2 \cdot 2\text{H}_2\text{O}$ in the presence of water in 1 wk or more.

It is easy to understand why early observers believed that the first compound to precipitate

was a dihydrate. If the sample is not scrupulously dried immediately after preparation and kept dry, it will convert to the dihydrate and be analyzed as such after routine drying.

One can therefore deduce that in the presence of water, the dihydrate is the only stable compound; it does not form immediately only due to nucleation difficulties. The appearance of the β -tetrahydrate is then an intermediate metastable phase on the way to stability (Ostwald's step rule). In the presence of a small amount of water, a powdered mixture of all three hydrates converts rapidly to the dihydrate. Since these compounds transform in this way in the presence of water, as diagrammed by the dotted lines in Fig. 1, any solubility data such as that of Meusser referred to above, particularly for the α -tetrahydrate (his α -dihydrate) is unreliable, since values obtained will depend on the length of time used as well as on the nuclei present.

If the α -tetrahydrate is filtered and air-dried as soon as it has formed, it will contain at most small amounts of the β -tetrahydrate and can be kept essentially indefinitely in a desiccator in a refrigerator. Similarly, the air-dried β -tetrahydrate is quite stable in a desiccator. Only in the presence of added water will it begin to convert to the dihydrates; although the latter contains less water, a liquid phase appears to be required for nucleation of the stable phase to occur. The dihydrate precipitates directly at 90°C .

The α -tetrahydrate when dry begins to convert

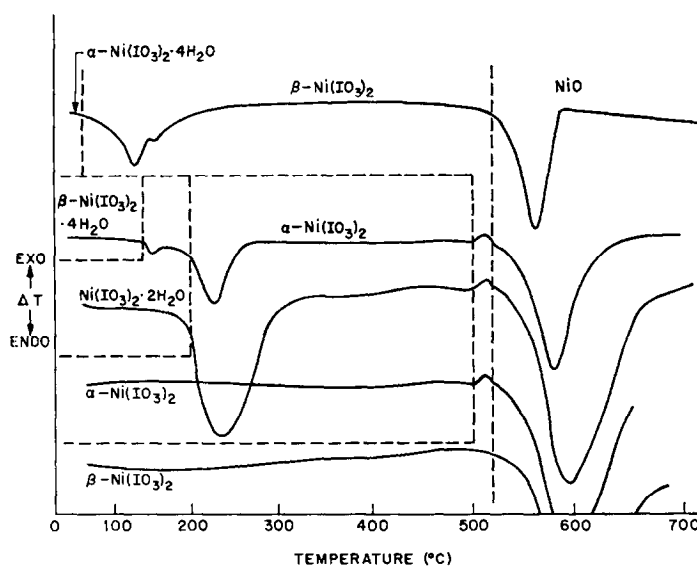

FIG. 2. DTA curves of the nickel iodates.

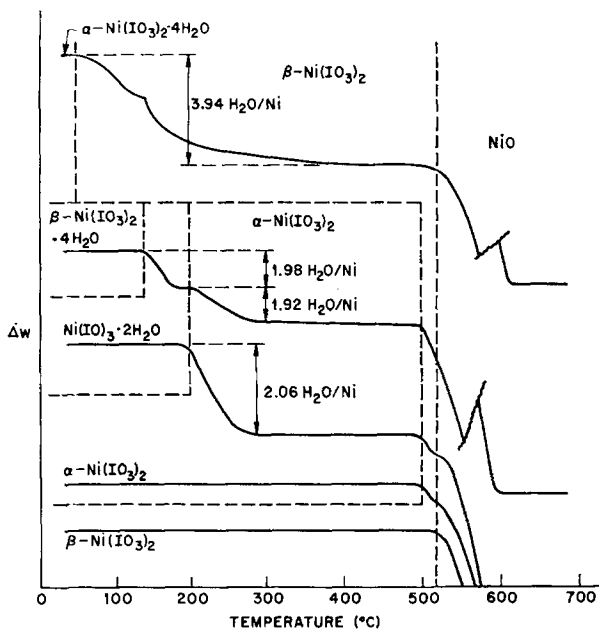

FIG. 3. TGA curves of the nickel iodates.

to the yellow anhydrous $\beta\text{-Ni}(\text{IO}_3)_2$ above 50°C . The β -tetrahydrate converts to the dihydrate when dry at 140°C , while the dihydrate converts to the green α -anhydride at 200°C . These changes are summarized in Fig. 1 and can be seen in detail in the DTA and TGA curves of Figs. 2 and 3. Large crystals of the dihydrate 10 mm in length have been grown from boiling water solution (10).

The green $\alpha\text{-Ni}(\text{IO}_3)_2$ converts to yellow $\beta\text{-Ni}(\text{IO}_3)_2$ only 20°C below the decomposition temperature of 520°C , but the β -anhydride can be crystallized directly from solution in boiling nitric acid. As shown in Fig. 2, the anhydride α to β transition is unexpectedly exothermic on heating. It may be that the α -anhydride is in fact a metastable phase. The small weight loss seen in the TGA curves of Fig. 3 at 500°C indicates different decomposition rates for the two anhydrides.

These relationships were established on the basis of thermal analysis and numerous X-ray powder diffraction patterns. Since all these compounds, except for the yellow $\beta\text{-Ni}(\text{IO}_3)_2$, are not greatly differing shades of green, it is not possible to sight-identify and to handpick material as is the case in the cobalt system.

Meusser (4) stated that neutral solutions may be used; we have found that the use of LiIO_3

appears to give essentially identical results as acid solutions, but the use of KIO_3 can result in some potassium-containing double salts which were not further investigated. We have found no evidence for compounds containing more than four water molecules per nickel iodate molecule.

iii. Properties

$\alpha\text{-Ni}(\text{IO}_3)_2 \cdot 4\text{H}_2\text{O}$ is the first compound to precipitate from solution and rapidly converts to $\beta\text{-Ni}(\text{IO}_3)_2 \cdot 4\text{H}_2\text{O}$ when wet. It is medium-green and when dry is barely stable; conversion to yellow $\beta\text{-Ni}(\text{IO}_3)_2$ begins at about 50°C (Figs. 1, 2, and 3). As can be seen in the DTA and TGA curves, some of the β -tetrahydrate is present as a contaminant. If a sample is held for 0.5 hr at 130°C , essentially complete conversion to the yellow β -anhydride occurs. Optical constants are given in Table I.

$\beta\text{-Ni}(\text{IO}_3)_2 \cdot 4\text{H}_2\text{O}$ is a medium green substance, stable when dry to 140°C (Figs. 1, 2, 3) where it converts to the dihydrate with the loss of 14.6, 15.2% H_2O (theory = 14.98%). In the presence of water it also converts slowly to the dihydrate. Single crystals 2 to 3 mm in size form from a mixture of $\alpha\text{-Ni}(\text{IO}_3)_2 \cdot 4\text{H}_2\text{O}$ and its precipitation solution or water at room temperature over a period of several days. Optical constants are given in Table I.

TABLE I
OPTIC PARAMETERS OF THE NICKEL IODATES^a

	Character and sign	Refractive indexes	Color and pleochroism	Optic angle	Point group ^b
α -Ni(IO ₃) ₂	nd	nd	Green(nd)	nd	nd
β -Ni(IO ₃) ₂	Uniaxial (-)	1.89, —, >2.00	Yellow(nd)	0	6
Ni(IO ₃) ₂ ·2H ₂ O	Biaxial (-)	1.75, 1.83, 1.85	Green(nd)	Small	<i>mmm</i>
α -Ni(IO ₃) ₂ ·4H ₂ O	nd	nd	Green(nd)	nd	nd
β -Ni(IO ₃) ₂ ·4H ₂ O	Biaxial(nd)	1.68, nd, 1.80	Green(nd)	nd	2/ <i>m</i>

^a nd means not determined.

^b As determined by X-rays in II.

Ni(IO₃)₂·2H₂O (previously referred to as the β -compound) is an emerald green material, readily crystallized from boiling water solution (10). Crystals up to 0.5 in. in length were grown in three stages from a total of 6 liters of solution over a 6 wk period. It decomposes at 200°C (Pechkovskii and Sofronova (18) give 210°C), shown in Figs. 1, 2, and 3, to the green α -anhydride, with the loss of 7.98 to 8.34% H₂O (theory = 8.10%). The optical absorption data of Sect. 4 indicate that the "nickel iodate hydrate" of Rocchiccioli (14) is the dihydrate. Optical constants are given in Table I.

The structure, determined by Abrahams and Bernstein (20), is orthorhombic *Pbca* with unit cell $a = 9.14986$, $b = 12.20896$, and $c = 6.58353$ Å.

α -Ni(IO₃)₂. This olive green compound is prepared by heating the dihydrate to 200°C. It converts exothermically to the yellow β -anhydride at 500°C, almost coincident with the onset of decomposition as shown in Figs. 2 and 3. Optical constants are given in Table I.

β -Ni(IO₃)₂. This bright yellow compound is prepared by heating the α -tetrahydrate above 50°C or the α -anhydride to 500°C, or by direct crystallization from boiling nitric acid (10) as acicular crystals. Decomposition begins while the compound is forming from the α -anhydride, and a mixture containing some NiO results by this route. Rapid decomposition begins at 520°C as shown in Figs. 2 and 3 with the formation of NiO; based on the amount of starting compound the residue after TGA to 700°C corresponded to molecular weights of 72, 75, and 76 (theory for NiO = 74.7); this was confirmed to be NiO by X-ray powder diffraction.

Pechkovskii and Sofronova (18) reported the decomposition at 490°C, but did not observe the intermediate formation of the α compound. Analytical data on acid grown crystals dried at 110°C were in reasonable agreement with theory:

	% Ni	% I
β -Ni(IO ₃) ₂ —SI045	13.07, 15.01	61.42, 61.91
Calculated for Ni(IO ₃) ₂	14.37	62.13

The optical absorption data of Sect. 4 indicate that the Ni(IO₃)₂ examined by Dasent and Waddington (13) was the β -anhydride. Optic constants are given in Table I. The X-ray diffraction data show this compound to be isostructural with the cobalt, manganese, and ferric anhydrous iodates.

B. Cobalt Iodate and its Hydrates

i. Historical

Early work reported the existence of 0, 1, or 1½, 2, 3, 4, 5, and 6 hydrates of Co(IO₃)₂. Meusser (4) studied the system and, based on solubilities, found only a tetrahydrate unstable in solution at all temperatures, a dihydrate stable below 63°C and an anhydride stable above this temperature. Rosenberg (21) discussed Meusser's (unreliable because of metastability) solubilities in terms of activity coefficients. Rocchiccioli (14) gave the infrared bands of a hydrated cobalt iodate. Meijer and Handel (16) measured the magnetic susceptibility and specific heat at liquid helium temperatures, and Pechkovskii and Safronova (18) performed thermal analysis, on the dihydrate.

ii. Preparation

We find that the three compounds occurring in this system are the cobalt anhydride and the di- and tetrahydrate. They correspond closely to the Ni β -anhydride, dihydrate, and β -tetrahydrate; the first and last of these salts being in fact isostructural between Ni and Co. The study of the cobalt compounds is simplified by the fact that the colors are quite distinct, being intense purple, deep pink, and beige, respectively.

The tetrahydrate $\text{Co}(\text{IO}_3)_2 \cdot 4\text{H}_2\text{O}$ precipitates from acid or neutral solution at or below room temperature, often in millimeter size crystals. On standing in the presence of water for a number of days powdered tetrahydrate converts to the dihydrate, again with the formation of

millimeter size crystals. Near the boiling point of water the anhydride is the only product, and it can be crystallized from boiling water or nitric acid (10) in single crystal form. When dry, all three cobalt compounds are stable at room temperature, but in the presence of water both the tetrahydrate and the anhydride can form metastably, possibly due to difficulties in nucleating the stable phase. In Fig. 4 is shown a Teflon stirring-bar on which all three cobalt compounds crystallized overnight from a CoSO_4 - KIO_3 solution at room temperature.

iii. Properties

$\text{Co}(\text{IO}_3)_2 \cdot 4\text{H}_2\text{O}$ is a beige substance, stable when dry to 70°C , (Figs. 1, 5, 6) where it converts

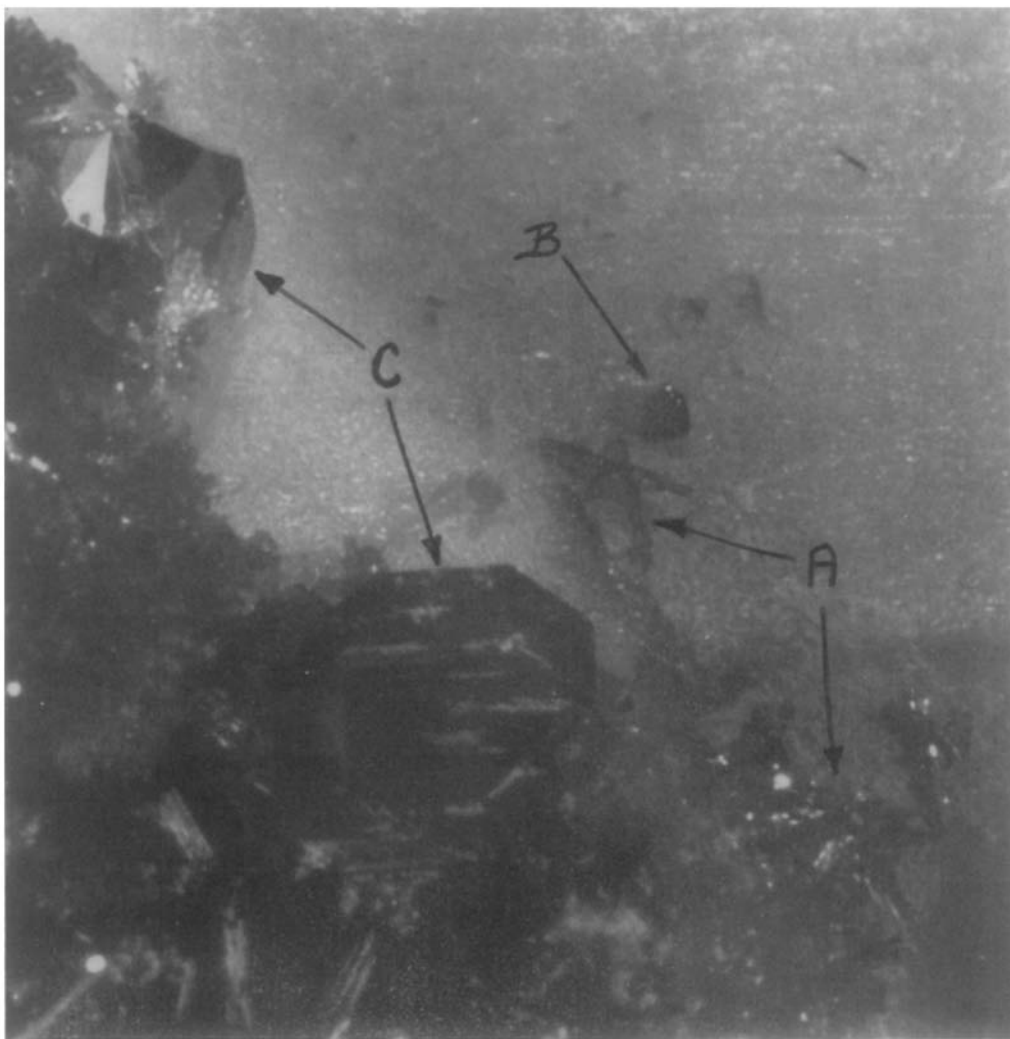

FIG. 4. Crystals of purple needles of $\text{Co}(\text{IO}_3)_2$ A), pink plates of $\text{Co}(\text{IO}_3)_2 \cdot 2\text{H}_2\text{O}$ (B), and beige $\text{Co}(\text{IO}_3)_2 \cdot 4\text{H}_2\text{O}$ (C), cocrystallized from CoSO_4 - KIO_3 solution ($\times 22.5$).

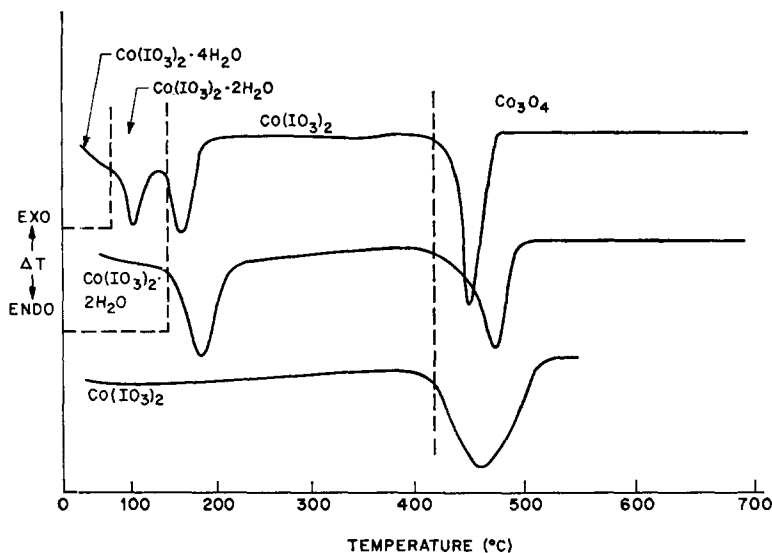

FIG. 5. DTA curves of the cobalt iodates.

to the anhydride with the loss of 14.8 to 15.6% water (theory = 14.98%). In the presence of water it converts slowly to the dihydrate. It is isostructural with $\text{Ni}(\text{IO}_3)_2 \cdot 4\text{H}_2\text{O}$. Optical constants are given in Table II.

$\text{Co}(\text{IO}_3)_2 \cdot 2\text{H}_2\text{O}$ is a deep pink compound readily crystallized from boiling water solution. It is stable up to 150°C (Pechkovskii and Sofronova (18) give 142°C) shown in Figs. 1, 5, and 6. At this temperature it decomposes to the anhy-

dride with the loss of 7.9 to 8.7% H_2O (theory = 8.10%). Based on the optical absorptions of Sect. 4, the "cobalt iodate hydrate" of Rocchiccioli (14) was the dihydrate. Optical constants are given in Table II.

$\text{Co}(\text{IO}_3)_2$ is an intensely colored purple material crystallizing from boiling water or nitric acid in acicular crystal (10). It decomposes at 420°C (Pechkovskii and Sofronova (18) give 415°C), shown in Figs. 1, 5, and 6, to Co_3O_4

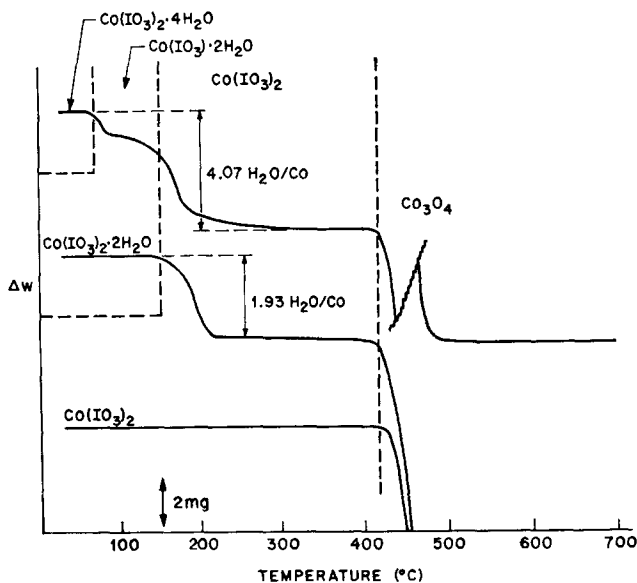

FIG. 6. TGA curves of the cobalt iodates.

TABLE II
OPTIC PARAMETERS OF THE COBALT IODATES^a

	Character and sign	Refractive indexes			Color and pleochroism	Optic angle	Point group ^b
		x	y	z			
Co(IO ₃) ₂	Uniaxial (-)	1.87	—	1.97	Purple (purple, purple)	0	6
Co(IO ₃) ₂ ·2H ₂ O	Biaxial (-)	1.71	1.79	1.85	Pink (red-brown, pink, purple)	Large	I
Co(IO ₃) ₂ ·4H ₂ O	Biaxial (-)	1.68	nd	1.76	Beige (brown, nd, purple)	Large	2/m

^a nd means not determined.

^b As determined by X-rays in II.

as determined by X-ray diffraction; the residue corresponding to a molecular weight of 228 to 258 (Co₃O₄ = 240.8). Analytical data on acid-grown crystals dried at 110°C gave good agreement with theory:

	% Co	% I
Co(IO ₃) ₂ —S1033	13.92, 14.31	60.98, 62.31
Calculated for Co(IO ₃) ₂	14.42	62.09

Optical constants are given in Table II.

C. Manganese Iodate

Among other investigators, Ditte in 1890 (22) examined the anhydrous divalent manganese compound. He reported it to be insoluble in boiling water and nitric acid. Hayes and Martin (23) reported a solubility product in water of

4.97×10^{-7} at 25°C and a heat of solution of 2280 cal/mole. Rocchiccioli (14) reported the infrared absorption spectrum without giving any preparation details.

Precipitation at temperatures from 0 to 100°C under acidic HIO₃ or neutral LiIO₃ conditions gave but one product. Crystallization from boiling water yielded clusters of the same compound in single crystal form as pink needles up to 2 mm long and 1/2 mm in diameter. The 25°C solubility product (23) gives a solubility of 2 g/liter; even at the boiling point the solubility increased to only about 3 g/liter. Boiling nitric acid could not be used to increase the solubility since it converts the compound slowly to an oxide. Even in boiling water there is some oxidation.

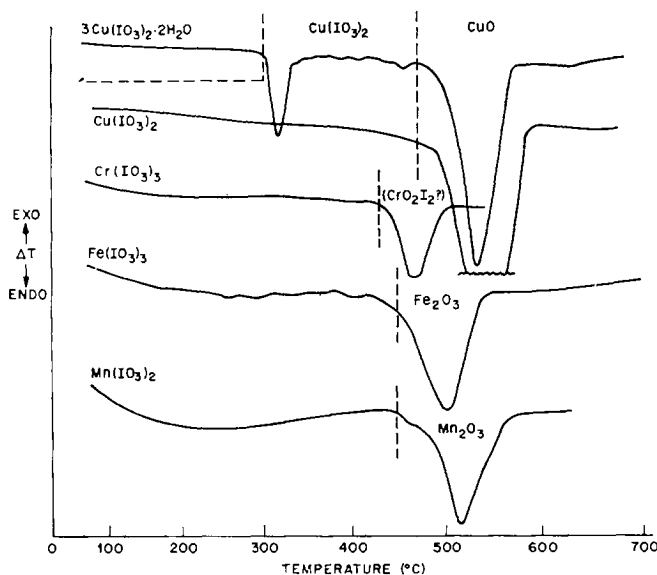

FIG. 7. DTA curves of the copper, iron, manganese, and chromium iodates.

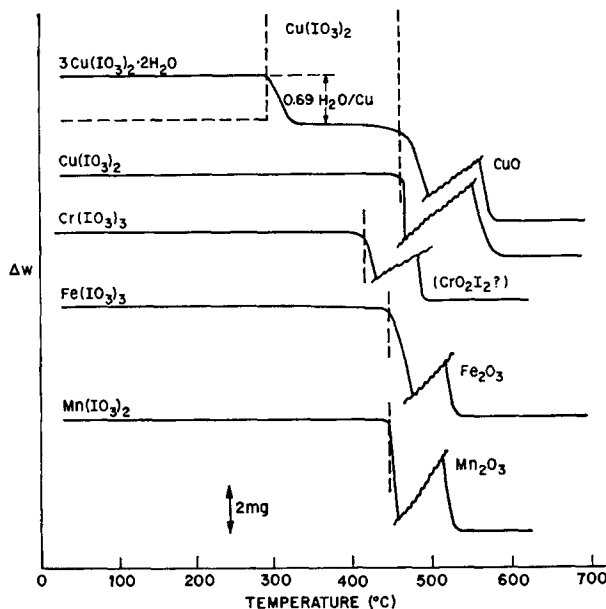

FIG. 8. TGA curves of the copper, iron, manganese, and chromium iodates.

DTA and TGA curves for $\text{Mn}(\text{IO}_3)_2$ are given in Figs. 7 and 8. They indicate the absence of H_2O and show decomposition at about 420°C . The product under nitrogen was Mn_2O_3 ; the residue corresponded to a molecular weight of 160, 168 ($\text{Mn}_2\text{O}_3 = 157.9$). Chemical analysis for the room temperature, iodic acid precipitated compound dried at 100°C confirmed the composition:

	% Mn	% I
$\text{Mn}(\text{IO}_3)_2$ —S1031	13.38, 13.62	62.69, 63.85
Calculated for $\text{Mn}(\text{IO}_3)_2$	13.57	62.71

Optical constants are given in Table III.

By precipitation with KIO_3 , powders containing potassium salts were obtained. Berg (24) reported double salts based on trivalent manganese; he found that $\text{Mn}(\text{IO}_3)_3$ itself was not stable except in the presence of excess HIO_3 in solution. These aspects were not pursued any further.

D. Chromic Iodate

Von Endrédy (25) reported $\text{Cr}(\text{IO}_3)_3$ with 0, 2, $4\frac{1}{2}$ and 5 hydrates, characterized only on the basis of analysis. Following his techniques we have obtained precipitates of variable water

TABLE III
OPTIC PARAMETERS OF THE Cr, Mn, Fe, AND Cu IODATES^a

Character and sign	Refractive indexes			Color and pleochroism	Optic angle	Point group ^b
	x	y	z			
$\text{Cr}(\text{IO}_3)_3$	nd	>2.0		Green	nd	nd
$\text{Mn}(\text{IO}_3)_2$	Uniaxial (-)	1.81,	—, 2.00	Pink ($x > z$)	0	6
$\text{Fe}(\text{IO}_3)_3$	Uniaxial (+)	1.80,	—, 1.95	Yellow-green (nd)	0	6
$\text{Cu}(\text{IO}_3)_2$	nd	nd		Cream (nd)	nd	nd
$3\text{Cu}(\text{IO}_3)_2 \cdot 2\text{H}_2\text{O}$	Biaxial (+)	1.90, 1.94,	1.96	Blue-green (nd)	Small	I
Bellingerite ^c	Biaxial (+)	1.890, 1.90,	1.99	Light-green ($z > x$ and y)	Medium	I

^a nd means not determined.

^b As determined by X-rays in II.

^c Naturally occurring $3\text{Cu}(\text{IO}_3)_2 \cdot 2\text{H}_2\text{O}$, from Chuquicamata, Chile, reported by Berman and Wolfe (27).

content (10 to 21% H₂O), showing no evidence for any constant water content regions on DTA or TGA. Neither these powders nor their dehydration products diffracted X-rays. When the room temperature HIO₃-Cr(NO₃)₃ precipitated product was dissolved in boiling water and evaporated, the same type of product was obtained.

However, when this powder was dissolved in boiling concentrated HNO₃ and filtered, a precipitate appeared overnight and a little more on continued boiling almost to dryness. This anhydrous green compound (Figs. 7 and 8) gave an X-ray powder diffraction pattern closely resembling (see II) that of Fe(IO₃)₃ as well as the divalent Mn, Co, and β-Ni iodates. The infrared absorptions of Sect. 4 were also consistent with Cr³⁺. Optic constants are given in Table III.

The analytical results were in reasonable agreement with the calculated values expected for trivalent Cr, as was expected since a chromic compound was used as reagent and HIO₃ is an oxidizing agent.

	% Cr	% I
Cr(IO ₃) ₃ —S1234	8.42	63.98
Calculated for Cr(IO ₃) ₃	9.02	66.01

After decomposition (above 420°C) very little residue remains indicating disproportionation to a volatile compound, presumably chromyl iodide CrO₂I₂.

E. Ferric Iodate

The only preparatory report during this century is that of Von Endrédy (25) who used several reactions to obtain products with slightly different properties as well as a doubtful dihydrate. These techniques were also used by Dasent and Waddington (13) to prepare a powder for infrared measurements.

Using the techniques of Von Endrédy, as well as other variations, only a single compound could be obtained as indicated by X-ray powder diffraction and thermal analysis. The compound is pale yellow-green, but readily turns brown when partially decomposed due to traces of Fe₂O₃ formed. DTA and TGA curves are shown in Figs. 7 and 8, indicating absence of water and decomposition about 450°C to Fe₂O₃; the residue corresponded to a molecular weight of 157 to 162 (Fe₂O₃ = 159.7). In some precipitations a considerable amount of water was loosely held, but thermal analysis gave no evidence for

the existence of any fixed hydrates. Undoubtedly this phenomenon resulted in Von Endrédy's report of decomposition at 130°C and a questionable (to him) dihydrate.

The solubility of about 0.35 g/liter reported by Von Endrédy (25) is too low for effective crystal growth, although tiny crystals, less than 0.1 mm long were obtained by the evaporation of 2 liters of saturated solution. These crystals again ranged from yellow-green to brown. They were large enough for single crystal X-ray diffraction to confirm the structural identity with several divalent anhydrous iodates shown in Fig. 1, as well as with Cr(IO₃)₃.

The analytical results on a sample precipitated at 95°C and dried at 110°C were:

	% Fe	% I
Fe(IO ₃) ₃ —S1028d	9.67, 9.57	65.62, 65.38
Calculated for Fe(IO ₃) ₃	9.62	65.58

Optic constants are given in Table III. The absorption band at 21 700 cm⁻¹ as described in Sect. 4 is consistent with Fe³⁺ as distinct from Fe²⁺ (see e.g., Wood and Nassau (26)). This, together with the excellent agreement of the analytical data, the fact that a ferric salt was used as a starting material, and that the iodic acid also used is an oxidizing agent leaves no doubt that ferric iodate was obtained. Trivalent Fe iodate is isostructural with the divalent Mn, Co, and β-Ni iodates; the implications of this are discussed in II.

F. Copper Iodate and the Hydrate, Bellingerite

A series of authors have reported a copper iodate monohydrate Cu(IO₃)₂·H₂O obtained by precipitation from neutral or acid solutions [e.g. (5-8)]. Subsequently the mineral bellingerite 3Cu(IO₃)₂·2H₂O was reported by Berman and Wolfe (27), and its structure was determined by Kaplan (28). Berman and Wolfe noted the identity of bellingerite with Granger and De Schulten's (5) monohydrate, but this comment was ignored and a variety of data published for the monohydrate deal in fact with the bellingerite composition as discussed elsewhere (29).

We have obtained bellingerite 3Cu(IO₃)₂·2H₂O by precipitation with HIO₃ from 0°C to the boiling point. By using neutral solutions mixtures are obtained which we have not succeeded in characterizing. The solubility in water at room temperature is 1.5 g/liter and in concentrated

nitric acid about 8 g/liter at the boiling point. Bellingerite was crystallized from both boiling water and boiling concentrated nitric acid solutions in crystals up to 12 mm across (10). The crystals are blue with a density of 4.89 (27), 4.88 (6).

The DTA and TGA results of Figs. 7 and 8 show that $3\text{Cu}(\text{IO}_3)_2 \cdot 2\text{H}_2\text{O}$ loses its water and converts to the anhydride at 300°C . If not carefully freed of excess HIO_3 the water loss temperature was observed to occur as low as 135°C , probably explaining the 170 to 180°C decomposition temperature previously reported (8).

The product of dehydration is the anhydride $\text{Cu}(\text{IO}_3)_2$, obtained as a pale green powder by heating for 10 min at 300°C . At higher temper-

atures and longer heating times the compound is easily turned brown by decomposition products; it decomposes rapidly at about 450°C (as shown in Figs. 13 and 14) to CuO ; the molecular weight calculated from residue was 78, 80 ($\text{CuO} = 79.5$).

Analytical results confirm the $2/3$ hydrate and anhydride formulas:

	% Cu	% I	% H_2O
$3\text{Cu}(\text{IO}_3)_2 \cdot 2\text{H}_2\text{O}$ — S1035	15.10, 14.97	59.45, 59.90	2.7, 2.8
Calculated for $3\text{Cu}(\text{IO}_3)_2 \cdot 2\text{H}_2\text{O}$	14.94	59.68	2.82
$\text{Cu}(\text{IO}_3)_2$ —S1038H	15.40, 15.12	61.17, 61.13	—
Calculated for $\text{Cu}(\text{IO}_3)_2$	15.37	61.40	—

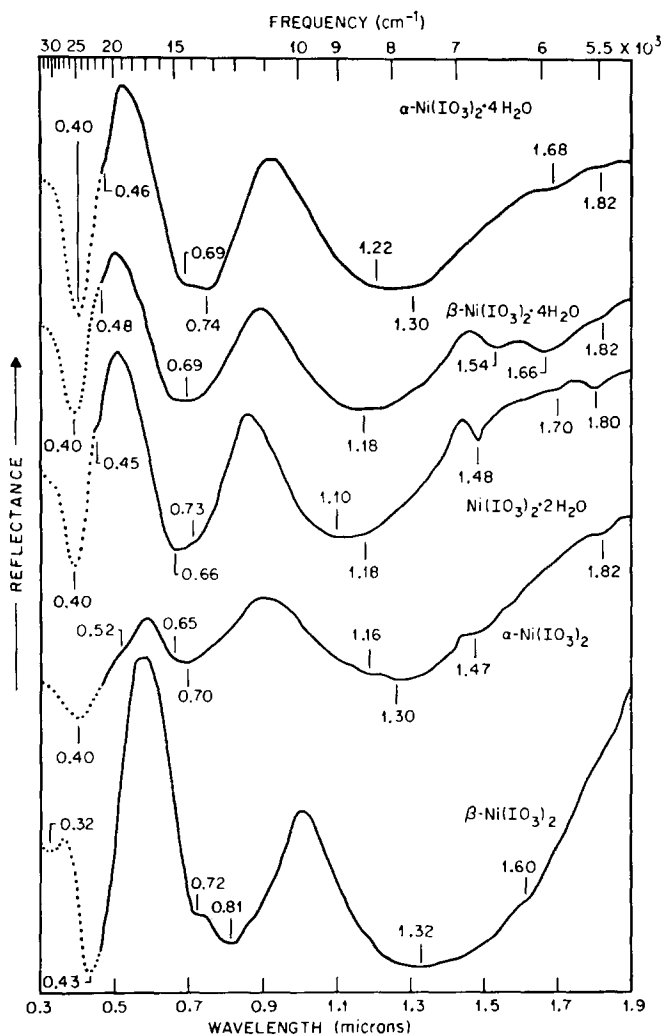

FIG. 9. Diffuse reflectance curves of the Nickel iodates in the $33\ 000$ to $5300\ \text{cm}^{-1}$ region.

Occasionally some green crystals or crystal regions are found with the blue $3\text{Cu}(\text{IO}_3)_2 \cdot 2\text{H}_2\text{O}$ when crystallizing from boiling HNO_3 . A pale green product obtained by Granger and De Schulten (5, 6) under similar conditions was considered to be the anhydride. However, we find this material to be bellingerite based on X-ray powder diffraction results; the cause for the off-color is not known but NO_2 inclusions may be suspected.

There also exists a hydroxy-iodate of copper, the mineral salesite $\text{Cu}(\text{IO}_3)(\text{OH})$, described by Palache and Jarrell (30), with a structural determination by Ghose (31). This compound was reported to be obtained by a $\text{Cu}(\text{NO}_3)_2$, HNO_3 , KIO_3 recipe by Granger and De Schulten (5, 6). Following their procedure, as well as some modifications, we repeatedly obtained only bellingerite.

G. Titanium and Vanadium Iodates

Ladwig (32) reported on the compound $\text{VO}_2 \cdot \text{IO}_3 \cdot 2\text{H}_2\text{O}$ or $\text{V}_2\text{O}_5 \cdot \text{I}_2\text{O}_5 \cdot 4\text{H}_2\text{O}$ which previously had also been assigned the formulation $\text{I}(\text{OH})_4(\text{VO}_3)$ (33). Other related vanadyl iodate hydrates have been reported (33). In view of the oxidizing nature of HIO_3 and the ready oxidation of V in lower valence states, it seems unlikely that iodates other than those of vanadyl would exist.

Rây and Saha (34) have reported the following titanium iodates: $\text{H}_2[\text{Ti}(\text{OH})_4(\text{IO}_3)_2]$; $\text{H}_2[\text{Ti}(\text{OH})_2(\text{IO}_3)_2]$ or $\text{Ti}(\text{IO}_3)_2 \cdot 2\text{H}_2\text{O}$, $\text{TiO}(\text{IO}_3)_2$, and $\text{Ti}(\text{IO}_3)_4$; $\text{H}_2[\text{Ti}(\text{IO}_3)_6] \cdot 2\text{H}_2\text{O}$, $\text{H}_2[\text{Ti}(\text{IO}_3)_6] \cdot \text{H}_2\text{O}$, and $\text{H}_2[\text{Ti}(\text{IO}_3)_6]$. Analysis and molar volumes (densities) appear to have been the only characterizations used.

We have attempted to prepare some of these Ti compounds; the products have shown variable or no X-ray diffraction, thermal analysis showed variable water content and no fixed hydrate compositions, and analyses showed I/Ti ratio varying from 2 to 20.

It does not appear likely that simple iodates of either V or Ti exist analogous to those of Cr through Cu described above. Accordingly these compounds were not further investigated.

4. Optical Absorption Data

The optical reflectance data in the 5300 to 33 000 cm^{-1} region are given for the Ni iodates in Fig. 9, for the Co compounds in Fig. 10, and

for the Cu, Cr, Fe, and Mn compounds in Fig. 11. The absorbance data in the 4000 to 35 cm^{-1} region is presented for all the hydrates in Figs. 12 and 13, and for the anhydrous compounds in Figs. 14 and 15.

These spectra show three general types of absorption feature. In the visible region 33 000 to 14 000 cm^{-1} and a little beyond are found the absorptions originating in the transition metal ions. Here the data are consistent with the known transition metal content; as discussed in Sects. 3D and E, both Cr and Fe iodates are trivalent. The visually observed colors of the compounds are consistent with the absorptions and reflections following the table of hues associated with spectral energy bands as given by Burnham, Hanes and Bartleson (35).

The hydrates all show absorptions attributable to hydrogen bonded water molecules. In liquid water absorptions occur at 3756 and 3652 cm^{-1} (asymmetric and symmetric O-H stretching modes), and 1595 $^{-1}$ (H-O-H bending mode) [Herzberg (36)], and other absorptions in the 14 000 to 4000 cm^{-1} region occur at 13 200,

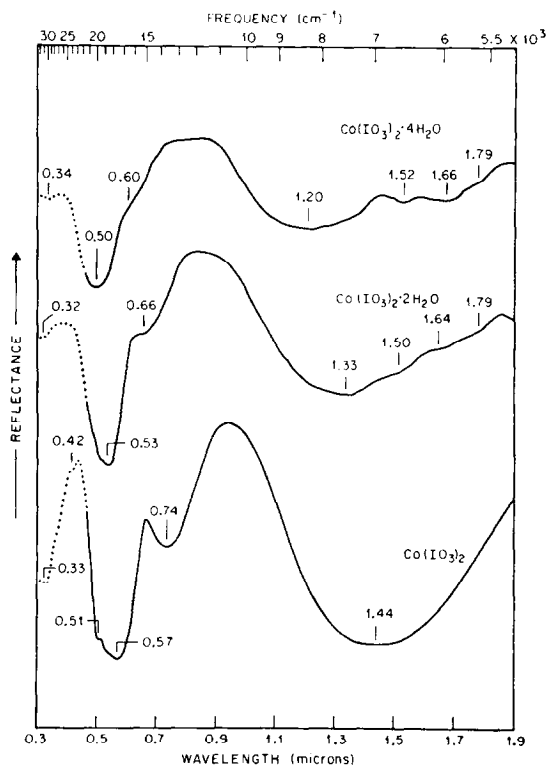

FIG. 10. Diffuse reflectance curves of the Cobalt iodates in the 33 000 to 5300 cm^{-1} region.

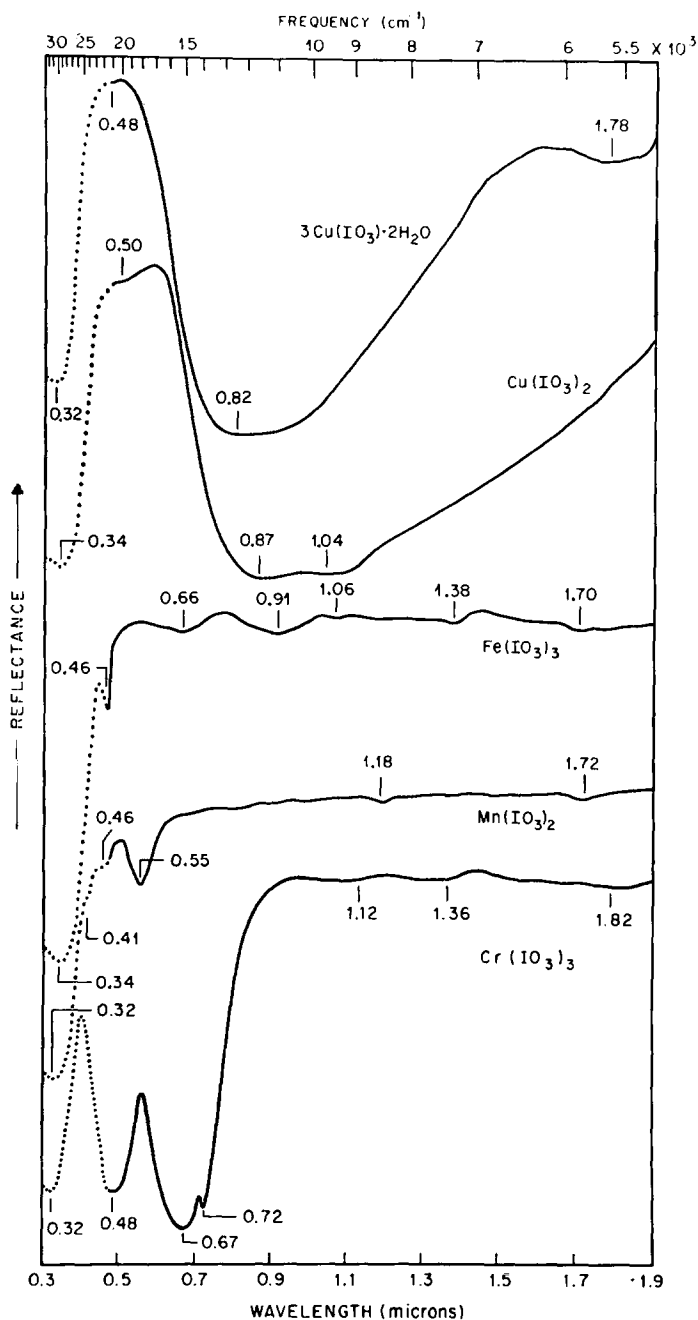

FIG. 11. Diffuse reflectance curves of the copper, iron, manganese, and chromium iodates in the 33 000 to 5300 cm^{-1} region.

10 300 8400, 6800, and 5150 cm^{-1} , with the intensity of these weak absorptions increasing in this order [Curcio and Petty (37)].

The three fundamentals are the most prominent indicators for water in these compounds, and as a group are present in all the hydrates and absent

in all the anhydrides. These bands are shifted and broadened by hydrogen bonding, the most extreme case being $3\text{Cu}(\text{IO}_3)_2 \cdot 2\text{H}_2\text{O}$ where the most prominent fundamental stretching mode is shifted to 2905 cm^{-1} ; in the other hydrates this feature is found in the 3240–3070 cm^{-1} region.

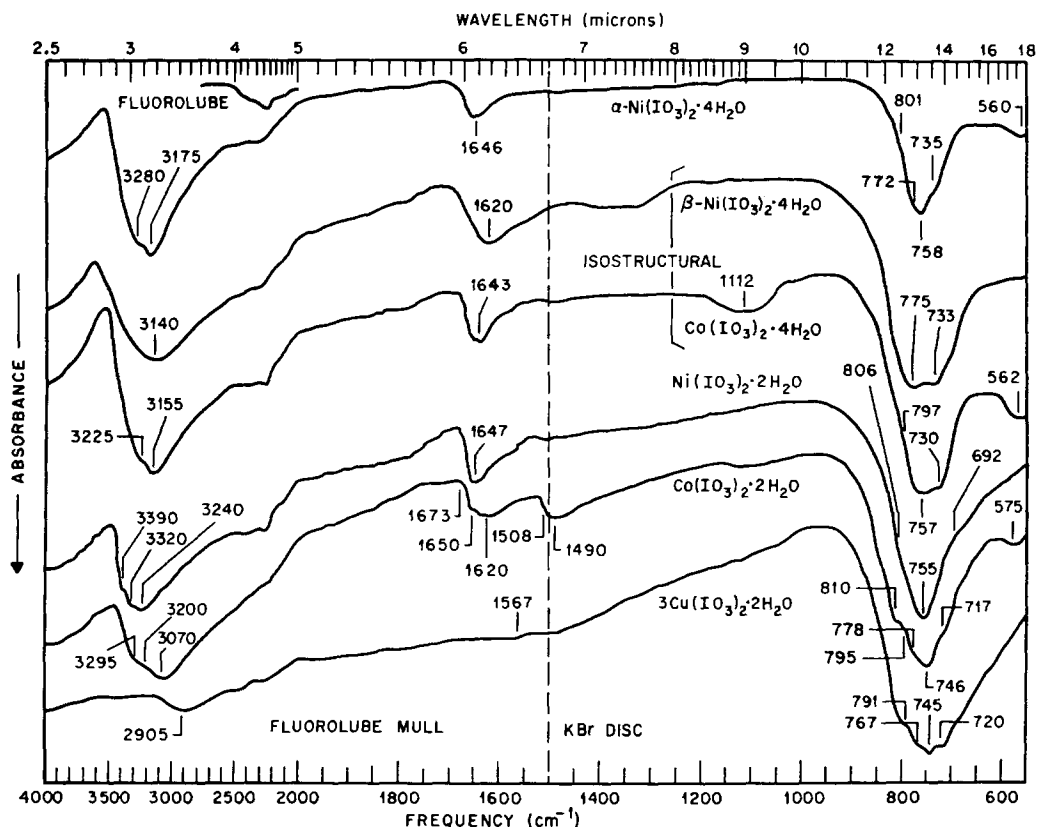

FIG. 12. Absorbance curves of hydrated iodates in the 4000 to 550 cm^{-1} region.

The occurrence of the 1600 cm^{-1} band is a specific indication for H_2O as distinct from $-\text{OH}$; H_2O rather than $-\text{OH}$ is also expected on chemical grounds.

The last set of features, due to vibrations involving metal, iodine, and oxygen atoms, are found prominently near 750 cm^{-1} , and also at lower frequencies. The four fundamental frequencies of the pyramidal iodate ion, both infrared and Raman active, have been observed in a variety of iodate crystals as well as in iodate solutions (13, 14, 38). They are ν_1 (symmetric stretching) at 630 to 780 cm^{-1} , ν_2 (symmetric bending) 350 to 400 cm^{-1} , ν_3 (asymmetrical stretching) 730–820 cm^{-1} , and ν_4 (asymmetric bending) at about 330 cm^{-1} . Thus the dominant absorption band found at 700 to 800 cm^{-1} in all of these compounds can be expected to contain ν_1 , $2\nu_2$, ν_3 , $2\nu_4$, and $\nu_2 + \nu_4$, as well as the possible splitting of ν_3 (13). The largest number of peaks resolved in this region is seven in $\text{Mn}(\text{IO}_3)_2$, while most of the compounds show four resolved peaks. Specific assignments were not attempted.

Three reports have listed a limited number of absorption bands of some of these iodates, with no preparation description or characterization. Based on our data we can clearly identify all of these compounds with one exception. The bands at 339, 357, 381, 445, and 582 cm^{-1} given by Rocchiccioli (14) for "Cu iodate, hydrated or anhydrous" match neither of our Cu compounds; the remaining bands at 725–743, 765, and 798 cm^{-1} , however, do match reasonably with either $\text{Cu}(\text{IO}_3)_2$ or with $3\text{Cu}(\text{IO}_3)_2 \cdot 2\text{H}_2\text{O}$. The same author's five bands for "Mn iodate," seven bands for "Ni iodate hydrate" and 10 bands for "Co iodate hydrate" give a good match for our $\text{Mn}(\text{IO}_3)_2$, $\text{Ni}(\text{IO}_3)_2 \cdot 2\text{H}_2\text{O}$, and $\text{Co}(\text{IO}_3)_2 \cdot 2\text{H}_2\text{O}$, respectively. Dastin and Waddington's (13) three bands for $\text{Ni}(\text{IO}_3)_2$ and four bands for $\text{Fe}(\text{IO}_3)_3$ agree with our data for $\beta\text{-Ni}(\text{IO}_3)_2$ and $\text{Fe}(\text{IO}_3)_3$, respectively.

Nyquist and Kagel (39) show curves for two transition metal iodates. Their " $\text{Cr}(\text{IO}_3)_3 \cdot x\text{H}_2\text{O}$," number 864, does not correspond to our $\text{Cr}(\text{IO}_3)_3$ and is accordingly not a

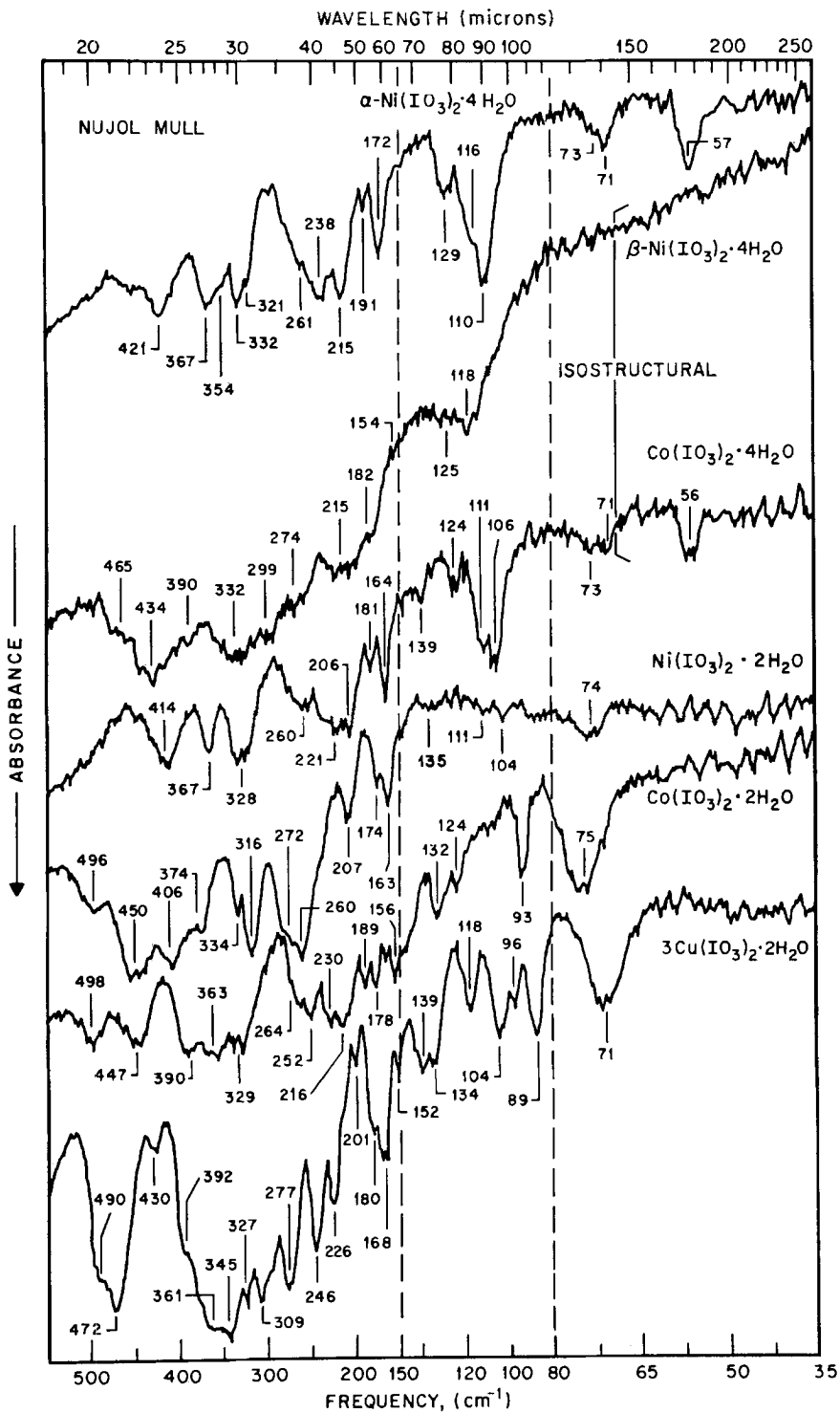

FIG. 13. Absorbance curves of hydrated iodates in the 550 to 35 cm⁻¹ region.

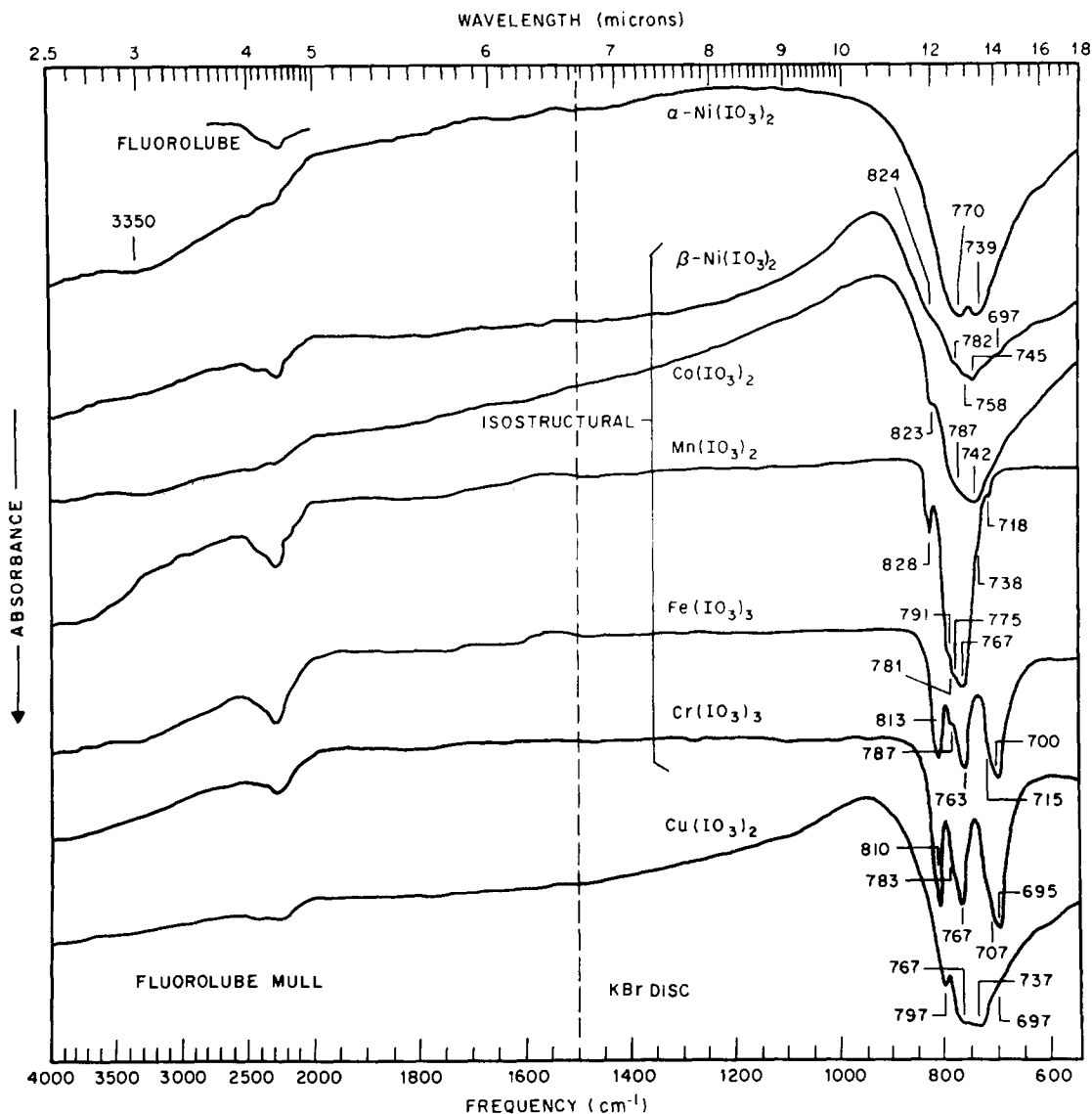

FIG. 14. Absorbance curves of anhydrous iodates in the 4000 to 550 cm^{-1} region.

definite compound but one of the mixtures discussed in Sect. 3D. Their " $\text{Ni}(\text{IO}_3)_2 \cdot x\text{H}_2\text{O}$ (plus impurity at 1683 cm^{-1})," number 865, corresponds to our $\text{Ni}(\text{IO}_3)_2 \cdot 2\text{H}_2\text{O}$ spectrum. Their "impurity at 1683 cm^{-1} " is an essential part of this spectrum, occurring in all the iodate hydrates as discussed in this section. However their band at 1385 cm^{-1} is not, and can be identified as originating from contamination with $\text{NiNO}_3 \cdot 6\text{H}_2\text{O}$; this band originates from the strong fundamental ν_3 vibration which dominates most nitrate spectra (40).

5. Summary

The iodates of Cr, Mn, Fe, Co, Ni, and Cu and their hydrates have been examined in detail. Of the many formulations previously reported only 13 were found to be valid, and nine of these were prepared in single crystal form. Most early work suffered from lack of characterization. We have accordingly presented preparatory details, crystal growth information, and the results of DTA, TGA, optical absorption and optic constant measurements so as to prevent future

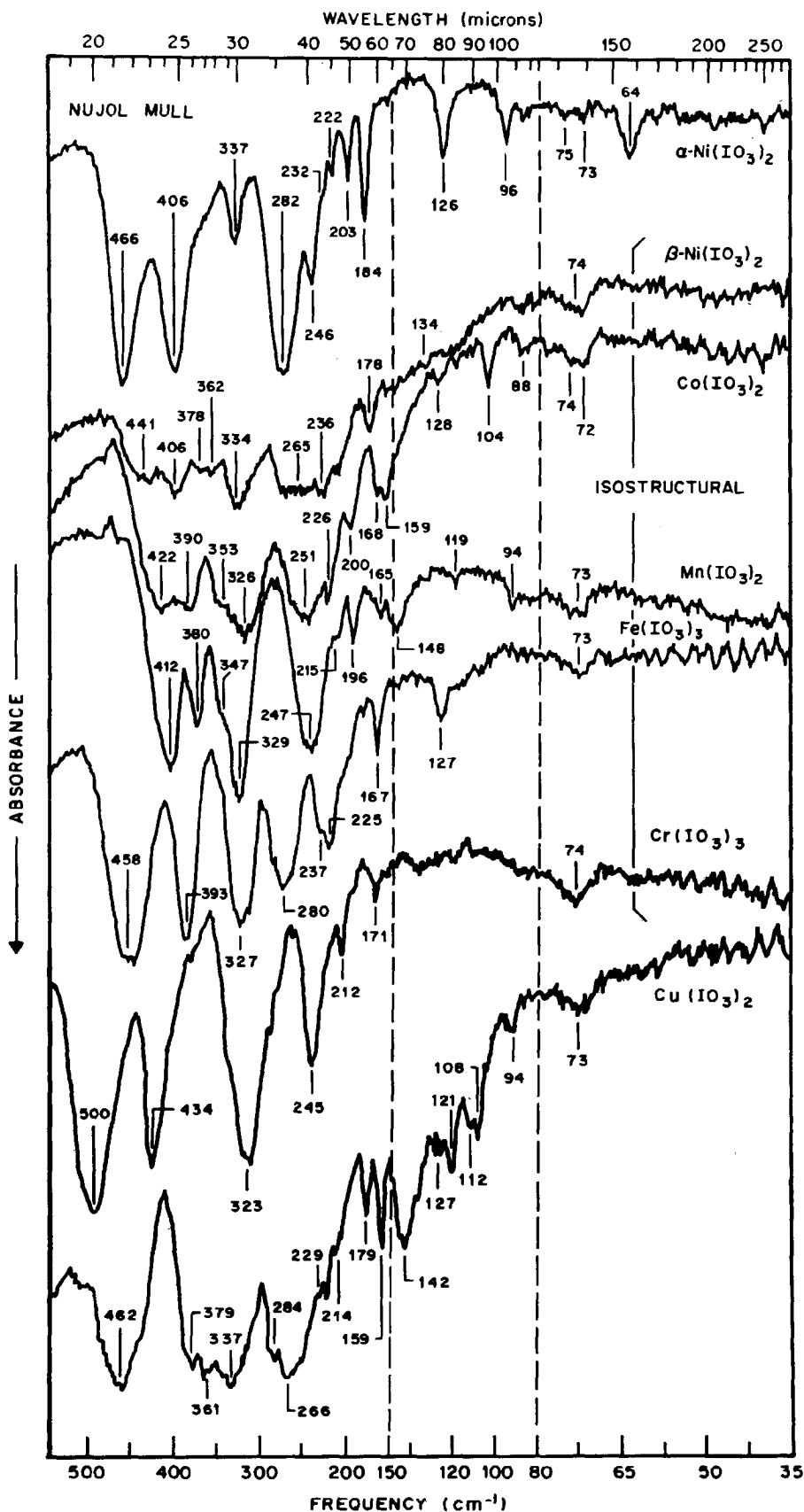

FIG. 15. Absorbance curves of anhydrous iodates in the 550 to 35 cm⁻¹ region.

confusion due to lack of reference data. X-Ray diffraction results, magnetic properties, and some nonlinear optical properties are presented in Part II of this series.

Notes added in proof:

(1) An improved way of specifying the colors of these iodates uses the Supplement (Standard Samples #2106) to NBS Circular #553 (K. L. Kelly and D. B. Judd, U.S. Government Printing Office, Washington, D.C., 1965). According to these standards the colors listed should be: Table I: light grayish olive, brilliant yellow, strong green, light green, light green; Table II: deep violet, light reddish purple, medium pink; Table III: dark yellowish green, strong pink, light yellowish green, light yellowish green, light greenish blue.

(2) E. H. P. Cordfunke has kindly permitted us to see his preprint (*J. Inorg. Nucl. Chem.* in press) in which he discusses Ni and Co iodate hydrates. There are two differences: He has not observed our α -Ni(IO₃)₂·4H₂O; his compound should accordingly be designated β -Ni(IO₃)₂·4H₂O to correspond to our equivalent compound. He has, however, observed two Co iodate dihydrates; our compound should therefore be designated α -Co(IO₃)₂·2H₂O to correspond to his compound so designated; his second compound, metastable β -Co(IO₃)₂·2H₂O, is isostructural (*Pbca*, $a = 9.267$, $b = 12.184$, $c = 6.621$ Å) with his and our Ni(IO₃)₂·2H₂O.

(3) Additional copper iodate compounds have now been discovered and will be described in papers III and IV of this series.

Acknowledgments

We are grateful for extensive interactions with S. C. Abrahams, to Mrs. A. S. Cooper for taking the many X-ray powder diffraction patterns, and to R. L. Barns, D. L. Wood, and A. P. Ginsberg for helpful discussions.

References

1. J. G. BERGMAN, G. D. BOYD, A. ASHKIN, AND S. K. KURTZ, *J. Appl. Phys.* **40**, 2860 (1969).
2. E. T. KEVE, S. C. ABRAHAMS, AND J. L. BERNSTEIN, *J. Chem. Phys.* **54**, 2556 (1971).
3. S. C. ABRAHAMS, *Mater. Res. Bull.* **6**, 881 (1971).
4. A. MEUSSER, *Berichte* **34**, 2432 (1901).
5. A. GRANGER AND A. DE SCHULTEN, *Bull. Soc. Chim. Fr.* **31**, 1027 (1904).
6. A. GRANGER AND A. DE SCHULTEN, *Bull. Soc. Fr. Mineral. Cristallogr.* **27**, 137 (1904).
7. J. F. SPENCER, *Z. Phys. Chem.* **83**, 290 (1913).
8. J. MARTINEZ-CROS AND L. LE BOUCHER, *An. Soc. Espan. Fiz. Quim.* **33**, 229 (1935).
9. S. C. ABRAHAMS, R. C. SHERWOOD, J. L. BERNSTEIN, AND K. NASSAU, *J. Solid State Chem.* **7**, 205 (1973).
10. K. NASSAU, *J. Crystal Growth* **15**, 171 (1972).
11. D. WEIGEL, B. IMELIK, AND M. PRETTRE, *Bull. Soc. Chim. Fr.* **1962**, 1427 (1962).
12. J. C. BURGIEL, V. JACCARINO, AND A. L. SCHAWLOW, *Phys. Rev.* **122**, 429 (1961).
13. W. E. DASENT AND T. C. WADDINGTON, *J. Chem. Soc.* 2429 (1960).
14. C. ROCCHICCIOLI, *C. R. Acad. Sci.* **250**, 1232 (1960).
15. F. J. DU CHATENIER, B. M. BOERSTOEL, AND J. DE NOBEL, *Physica (Utrecht)* **30**, 1625 (1964).
16. H. C. MEIJER AND J. VAN DEN HANDEL, *Physica (Utrecht)* **30**, 1633 (1964).
17. H. C. MEIJER, L. M. W. A. PIMMELAAR, J. B. A. A. ELEMANS, AND J. VAN DEN HANDEL, *Physica (Utrecht)* **43**, 569 (1969).
18. V. V. PECHKOVSKII AND A. V. SOFRONOVA, *Russ. J. Inorg. Chem.* **11**, 829 (1966).
19. J. B. A. A. ELEMANS, B. VAN LAAR, AND B. O. LOOPSTRA, *Physica (Utrecht)* **57**, 215 (1972).
20. S. C. ABRAHAMS AND J. L. BERNSTEIN, unpublished data.
21. T. ROSENBERG, *Acta Chem. Scand.* **3**, 50 (1949).
22. A. DITTE, *Ann. Chim. Phys., Ser. 6* **21**, 157 (1890).
23. A. M. HAYES AND D. S. MARTIN, *J. Amer. Chem. Soc.* **73**, 4853 (1951).
24. A. BERG, *C. R. Acad. Sci.* **128**, 673 (1899).
25. A. VON ENDREĐY, *Z. Anorg. Allg. Chem.* **217**, 53 (1934).
26. D. L. WOOD AND K. NASSAU, *Amer. Mineral.* **53**, 777 (1968).
27. H. BERMAN AND C. W. WOLFE, *Amer. Mineral.* **25**, 505 (1940).
28. S. F. KAPLAN, PhD thesis, University of New Mexico, 1966; University Microfilms 66,11,715, Ann Arbor, MI., 1966.
29. K. NASSAU AND J. W. SHIEVER, *Inorg. Chem.* **11**, 2552 (1972).
30. C. PALACHE AND O. W. JARRELL, *Amer. Mineral.* **24**, 388 (1939).
31. S. GHOSE, *Acta Crystallogr.* **15**, 1105 (1962).
32. G. LADWIG, *Z. Anorg. Allg. Chem.* **353**, 311 (1967).
33. A. ROSENHEIM AND K. H. YANG, *Z. Anorg. Allg. Chem.* **129**, 181 (1923).
34. P. R. RAY AND H. SAHA, *Z. Anorg. Allg. Chem.* **208**, 100 (1932).
35. R. W. BURNHAM, R. M. HANES, AND C. J. BARTLESON, "Color," p. 55ff., Wiley, New York (1963).
36. G. HERZBERG, "Infrared and Raman Spectra of Polyatomic Molecules," pp. 58, 171, 272, 280, Van Nostrand, New York (1945).
37. J. A. CURCIO AND C. C. PETTY, *J. Opt. Soc. Amer.* **41**, 302 (1951).
38. N. R. RAO, *Indian J. Phys.* **16**, 71 (1942).
39. R. A. NYQUIST AND R. O. KAGEL, "Infrared Spectra of Inorganic Compounds," Academic Press, New York (1971).
40. C. C. ADDISON AND B. M. GATEHOUSE, *J. Chem. Soc.* 613 (1960).