

Determination of the Point Group of β -Ga₂O₃ from Morphology and Physical Properties

G. M. WOLTEN AND A. B. CHASE

Aerospace Corporation, El Segundo, California

Received November 5, 1974; in revised form, June 18, 1975

The lattice of β -Ga₂O₃ is metrically monoclinic. The crystal structure was reported in space group $C2/m$ (S. Geller, *J. Chem. Phys.* 33, 676 (1960)). However, monohedra are a constant feature of the crystal morphology, and enantiomorphous crystals have been found. The optical dispersion is asymmetric, and observations in the scanning electron microscope indicate polarity. Therefore, the point group is 1 and the space group $P1$. Although the crystal lacks any true symmetry, pseudosymmetry is extensive and accounts for the following observed twin laws: $[001]_{180}$, $[021]_{180}$, $[021]_{90}$, $[132]_{180}$, $[1\bar{3}2]_{180}$, and $(5\bar{1}2)_m$.

Introduction

The apparent symmetry and the lattice parameters of β -gallium oxide were reported first by Kohn et al. (3), and the structure was solved by Geller (1) in space group $C2/m$, tests for pyro- and piezoelectricity being negative. The structure, as reported by Geller, has two kinds of gallium atoms, respectively coordinated tetrahedrally and octahedrally.

The accepted lattice parameters are $a = 12.23$ Å, $b = 3.04$ Å, $c = 5.80$ Å, and $\beta = 103.70^\circ$. The enormous pseudosymmetry of the compound can be appreciated from an inspection of Table I, which lists possible pseudocells. The list is not necessarily exhaustive. When orienting a crystal of β -Ga₂O₃, one can take advantage of one aspect of the pseudosymmetry by noting that the c -axis is quasi-normal to (102) and hence coincides with the observable $\bar{2}04$ reciprocal lattice vector within about 0.01° .

Over the past 10 or more years, the second author has grown crystals of β -Ga₂O₃ on many occasions, initially by flame-fusion but mostly by crystallization from high-temperature solvents. Molten PbO-V₂O₅ mixtures were used on some occasions, but all the more

recent experiments employed mixtures of Li₂MoO₄ and MoO₃.

It was usually noticed, but until recently not investigated, that the morphological symmetry of the crystals appeared lower than that of the accepted point group $2/m$. When enantiomorphous forms were discovered in certain twins, to be described later, the questions raised thereby could no longer be ignored. The investigation, which will be described, led to the conclusion that the space group of β -Ga₂O₃ is $P1$.

Because of the pseudosymmetry, the crystal will be described in space group $C1$. $\alpha = \gamma = 90^\circ$, and the other lattice parameters are as in the hitherto accepted monoclinic cell. All indexing remains the same, except that there are no symmetry-related faces.

The Triclinic Cell

Although for descriptive purposes, the familiar monoclinic cell, now considered pseudomonoclinic, will be used, a conventional triclinic cell should be defined, and this has to be the Niggli or Dirichlet reduced cell.

The two shortest lattice translations of β -Ga₂O₃ are the b - and c -axes of the pseudo-

TABLE I
PSEUDOCELLS. (CONV. CELL IN $P1$, $001/\frac{1}{2}\frac{1}{2}0/010$)

Pseudocells	QN ^a to a_1	Dimensions				
201/010/001	(100)	23.8	3.0	5.1	ϕ	
201/080/005		23.8	24.3	25.4	C	
100/010/108		12.2	3.0	55.1	ϕ	
102/010/ $\bar{1}02$	(201)	14.7	3.0	18.7	ϕ	
102/010/ $\bar{1}03$	(301)	14.7	3.0	23.5	ϕ	
102/010/ $\bar{3}07$		14.7	3.0	60.8	ϕ	
101/010/ $\bar{1}08$		12.2	3.0	59.8	ϕ	
132/307/ $\bar{1}82$		17.3	60.8	29.0	ϕ	
132/130/021	(512)	17.3	19.5	8.4	ϕ	
031/ $\bar{3}10/010$		10.8	36.8	6.7	ϕ	
011/ $\bar{1}20/041$	($\bar{2}14$)	6.6	13.7	13.5	T	
022/ $\bar{1}20/041$		13.2	13.7	13.5	C	
021/021/ $\bar{1}10$	($\bar{1}12$)	8.4	8.4	12.6	T	
063/063/ $\bar{2}20$		25.2	25.2	25.2	C	

^a QN is the quasi-normal plane to the first-listed axis. Letters in the last column designate pseudosymmetry: ϕ = orthorhombic, T = tetragonal, C = cubic.

monoclinic cell. The third-shortest, not in the plane of the other two, goes from the origin to the center of the C-face, and its length is $\frac{1}{2}L_{110} = 6.30$ Å. To keep the angle obtuse, the $[\bar{1}\bar{1}0]$ direction was chosen. Rearranging the axes in the order $c < a < b$, the anorthic lattice parameters become:

$$\begin{aligned} a &= 5.80 & b &= 6.30 & c &= 3.04 \\ \alpha &= 102.7^\circ & \beta &= 90.0^\circ & \gamma &= 104.0^\circ. \end{aligned}$$

The matrix, monoclinic to triclinic, is $001/\frac{1}{2}\frac{1}{2}0/010$, and the inverse is $01\frac{1}{2}/00\frac{1}{2}/\frac{1}{2}00$.

Method of Investigation

A number of computer programs, written by the author, provided lists of interplanar spacings, interfacial angles, orienter settings, quasi-normal pairs of rows and nets and their obliquities, and lengths of direct and reciprocal lattice vectors. The indices of diffracted beams were established from their X-ray d -values and the orienter settings at which they were found. Crystal faces were indexed by observing them to be normal to the reciprocal lattice vectors found by X-ray diffraction and by their angular relationships, using the quarter-circle goniostat and telescope as a goniometer. Twin-laws were deduced from the angular relationships of duplicated X-ray reflections, the morphology of the twins, and the nature of the composition planes. Crystals observed under the microscope were indexed by comparison with crystals indexed by X-ray methods.

Crystal Habits

Table II is a complete description of β -Ga₂O₃ morphology, at least with respect to the crystals grown by us. The various habits are listed in decreasing frequency of occurrence down the page, and within each habit,

TABLE II
MORPHOLOGY OF β -Ga₂O₃

Common	Needles [001] and platelets (100)						
	$\bar{1}00$	100	210	$2\bar{1}0$	$20\bar{1}$	001	110
Moderately common	$\bar{1}00$	100	110	$\bar{1}\bar{1}0$	$20\bar{1}$	001	
Very rare	$\bar{1}00$	100	310	$3\bar{1}0$	$20\bar{1}$	001	110
	$\bar{1}00$	100	$2\bar{1}0$	$2\bar{1}0$	$20\bar{1}$	001	
One specimen only	$\bar{1}00$	100	$2\bar{1}0$	$2\bar{1}0$	$20\bar{1}$	001	$\begin{cases} 110 \\ \bar{1}10 \\ 1\bar{1}0 \\ \bar{1}10 \end{cases} \begin{cases} \bar{1}11 \\ 11\bar{1} \\ \bar{1}\bar{1}1 \\ 1\bar{1}\bar{1} \end{cases}$
Observed occasionally in some twins only (in addition to those listed)			$2\bar{1}0$	201			$\begin{matrix} 131 & 211 \\ 131 & \text{or} \\ & 2\bar{1}\bar{1} \end{matrix}$

Not in order of size for this specimen only

the faces are listed, as is customary, in order of decreasing relative average size, with the one exception noted.

Whenever a three-dimensional crystal has two faces of the type $\{100\}$, they are of unequal size, and the negative index has been assigned arbitrarily to the larger one. The two ends of the c -direction are terminated respectively by $20\bar{1}$ on one end and 001 on the other. The choice of 001 as positive makes β obtuse, as required, and together the two choices just made determine the sense of b by the right-hand rule.

Table II shows 001 to be a monohedron in all cases. In fact, not once in hundreds of crystals was a $00\bar{1}$ observed to accompany the 001 . $20\bar{1}$ is a monohedron in all cases except the unusual "kite" twins that will be described. 110 is a monohedron in the more common morphologies but has a $1\bar{1}0$ companion in some of the less common ones. 100 is a monohedron only in the "kites," otherwise there always is a $\bar{1}00$, but it is never of the same size. The point group of most crystals is 1 . The one that comes closest to $2/m$ is the one labeled "one specimen only" in Table II, but even this crystal has the 001 monohedron.

Twinning

The majority of β -Ga₂O₃ crystals are twins. Most are twinned according to a law that has usually been referred to as (100) twinning, because the X-ray evidence can be interpreted as a reflection in the (100) plane, and the latter is also the composition plane. The X-ray evidence consists of duplicate $00l$ reciprocal lattice rows at an angle of $2(\beta - 90)^\circ$, and superposition of $h0l$ reflections with $(h + l)0\bar{l}$.

The axis that is quasi-normal to (100) is $[201]$, with an obliquity of 0.01° and twin index of 2. Because the obliquity is so close to zero, X-ray measurements cannot distinguish between the twin operations $(100)_m$ on one hand and $[201]_{180}$ on the other. In growth twinning, not necessarily in mechanical twinning, one usually finds the composition plane to be the twin plane if twinning occurs by reflection. For a rotation of 180° , the composition plane is more likely to be a

rhombic section, in this case $(10\bar{2})$, which contains the twin axis. In the case under discussion, the composition plane is (100) , and this favors $(100)_m$ over $[201]_{180}$ as the correct interpretation.

However, in any monoclinic or pseudo-monoclinic lattice, the ambiguity is a fourfold rather than a twofold one. The X-ray evidence can be interpreted equally as $[001]_{180}$, with (100) as the expected composition plane, or as a reflection in the plane quasi-normal to $[001]$ which is $(10\bar{2})$ in this case and would also be the likely composition plane. Since the composition plane actually found is (100) , the distinction to be made is between $(100)_m$ and $[001]_{180}$.

Most solvent-grown twins of β -Ga₂O₃ consist of just two crystals, often of unequal size. This is true of the most common habit, where both crystals in the twin exhibit the monohedra $20\bar{1}$, 001 , and 110 . Since these furnish unique markers for the positive and negative directions of the axial systems, it becomes possible to make the desired distinction unambiguously. The correct description of the twin law under discussion is $[001]_{180}$.

Two other twin laws, less common but not actually rare, are $[021]_{180}$ and $[021]_{90}$. The quasi-normal plane is $(\bar{1}12)$, with an obliquity of 2.70° . For the 180° rotation, the twin index is 2. The 90° rotation implies that $[021]$ is a pseudofourfold axis. Gruber's algorithm (2,6) was used to explore the character of the $(\bar{1}12)$ plane. To apply the algorithm, the primitive cell must be used in which $[021]$ and $(\bar{1}12)$ are $[10\bar{2}]$ and $(2\bar{1}\bar{1})$. The mesh of the plane is a rhomboid with an angle of 67.56° and sides of 7.50 and 7.62 Å. The diagonals of the mesh cross at a near-right angle and have lengths in the ratio 2:3, so that a 3×2 supermesh is nearly square and allows the $[021]$ to function as a fourfold axis. A further calculation indexed the diagonals as $[0\bar{2}1]$ and $[\bar{1}\bar{1}0]$, enclosing an angle of 89.05° . Their lengths are 8.40 and 12.60 Å, the ratio is 2:3, exactly.

Two more twins will be described in greater detail because they give rise to enantiomorphism. The "delta wings" are rare and very small, averaging only 0.2 mm in size. Figure 1 shows their simplest habit. Two

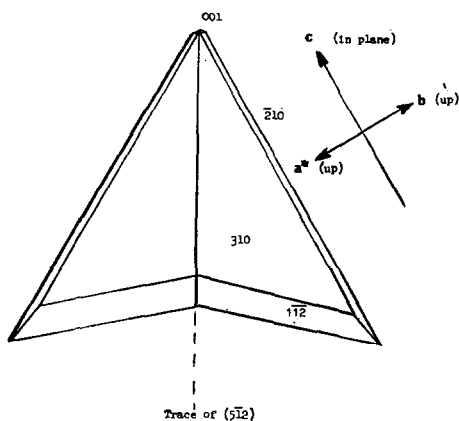

FIG. 1. Delta wing.

c-axes parallel the sides of the wings and enclose an angle of 59.7° . Very tiny 001 facets are present at the pointed end and are chosen as positive in accordance with the conventions adopted here. The top faces are (310) and form a shallow trough in the view shown, their normals are inclined 8° to one another. The "delta wings" are reflection twins, the twin plane is also the composition plane and is $(5\bar{1}2)$. The quasi-normal is $[1\bar{3}2]$, with an obliquity of 3.85° and a twin index of 3. The *b*- and *a**-axes, in the directions indicated for one crystal in Fig. 1, rise up from the mean

surface of the two 310's by 58.5° and 31.5° , respectively.

Most of the few wings found had additional faces that are difficult to index because of their small size. Possible indices for some are $(\bar{2}11)$ which sometimes truncates the $(\bar{2}10)$, and a $(\bar{2}\bar{1}0)$ that may appear underneath. Repeated $5\bar{1}2$ twinning, parallel to the major twin boundary at the centerline, produces shallow reentrant angles at the broad base.

In the illustration, only one of the crystals has been indexed. For reflection twins, it is customary to give all reflected planes the same indices but underline them to indicate that the axial system is now left-handed, thus $\underline{3}10$ and $\underline{3}\bar{1}0$. The main point to be made here is that each crystal in the twin is an object without symmetry, so that the two crystals are enantiomorphs.

A more dramatic case of enantiomorphism is presented by the "kite" twins shown in Fig. 2. They are produced in large yield at certain ratios of solute to molybdate solvent and may range up to several millimeters in size. The kite is a twin, and yet the whole kite has an enantiomorph. We designate the two objects as +kites and -kites; both have been found. In addition to the two kites being enantiomorphs of each other, each of the two crystals that make up a kite is the enantio-

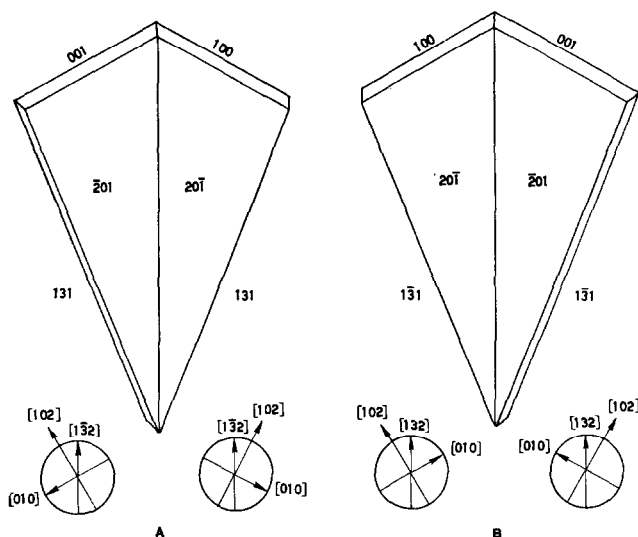

FIGURE 2

morph of one crystal in the other kite. The +kite will be described first.

The two crystals of the +kite are related by a 180° rotation about the midline [132], which is the twin axis. The quasi-normal plane is (512), with an obliquity of 3.85° and a twin index of 3. The composition plane is a rhombic section. It contains the twin axis and makes an observed angle of about 62° with the top face ($\bar{2}01$). These indices are for the right half of the kite, which has the positive direction of the *c*-axis sloping upward by 54° and the positive direction of the *a*-axis down by 50°. The projections of *a* and *c* onto the plane of the kite give the [102] direction. This is reversed in the left half, where in effect one looks at the underside of the right half and a (20 $\bar{1}$) face. The upper edges of the kite, forming the blunt point, are the directions of the *b*-axes, and their positive directions have been chosen as indicated in Fig. 2. Since the -kite is the mirror image, the sense of *b* has been reversed to keep the coordinate system right-handed for both. Twin axis and quasi-normal plane then become [1 $\bar{3}2$] and (5 $\bar{1}2$). In the "delta wings" (5 $\bar{1}2$) was the twin plane and [1 $\bar{3}2$] the quasi-normal axis, thus the twin-laws of these two twins are complementary to one another.

On very thin crystals, the short edges are 001 faces on both sides, as expected, one turned up and the other down. On slightly thicker crystals, this crossing of slopes seems to become a difficult growth problem. The twin responds by matching the 001 on one side with a 100 on the other, the difference in slopes now being only 4°. This is shown in Fig. 2, where one sees how this phenomenon compromises the rotational relationship morphologically. Of course, for the lattices, the relationship is inviolate as it must be. Occasionally a nearly vertical 102 modifies the 001 or the 100. The long edges that form the sharp point are both (1 $\bar{3}1$)'s. In contrast to most other faces, they were not identified by their X-ray reflections. However, it is clear from Fig. 2 that the sign distribution must be + - +, and (1 $\bar{3}1$) is the only index triplet of reasonably low values and the correct sign distribution that yields a face for which there is agreement between observed and calculated angles with $\bar{2}01$, 001, and [010]. The 1 $\bar{3}1$ faces

depart by 2° from a vertical orientation and always obey the rotational relationship, one up and one down. Note that the side faces are not needed to determine orientation, such as top and bottom. Once the directions of the *a*- and *c*-axes up or down from the plane of the kite have been determined by X-ray diffraction and their senses, plus or minus, assigned by reference to conventions, the enantiomorph is uniquely determined. Because of the twofold rotational symmetry about [132], the twin lattice remains unchanged when turned upside down. If the right half, with blunt point up, has a *c*-axis coming up from the plane, it still does so when turned over. The kite that has an *a*-axis coming up in this orientation is the mirror image and is called the -kite here.

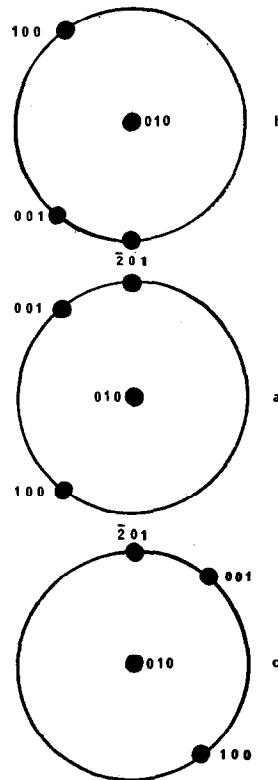

FIG. 3. Stereograms for kite enantiomorphs. (a) The +kite (right half as shown in Fig. 2). (b) +kite-reflected in (201). (c) b rotated 180° for direct comparison with a. It now represents the -kite (left half of -kite shown in Fig. 2).

In Fig. 2, both enantiomorphs have been indexed on a right-handed system, which necessitated reversing the sense of b for one of them. This was required for the X-ray examination, because the computer programs that calculate the orienter settings expect right-handed coordinate systems. However, the nature of the enantiomorphous relationship is seen more clearly if signs are not reversed arbitrarily and a left-handed system is used for one of the partners. The relationship is then seen to be a reflection in $(\bar{2}01)$. As positioned in Fig. 2, the right half of the +kite (2b on the right) is the mirror image of the left half of the -kite and vice versa. Reflection in a plane normal to the paper and parallel to $[132]$ is not a satisfactory explanation since this is not a rational plane. The enantiomorphous relationships are also shown in the stereograms of Fig. 3. The distinction between the right and left halves of a single kite is of course meaningful only with respect to the orientation in which they are viewed, otherwise they are congruent objects, structurally, although not always morphologically with respect to the 001 and 100 faces.

Optical, SEM, and SHG Observations

Optical dispersion. The interpretation of interference figures in white light is very difficult for β -Ga₂O₃ because of the vivid and highly anomalous interference colors. It is further complicated by the frequency of twinning. The acute bisectrix figure appears on the 100 face, but it is clear and centered only if one can view it on a thin untwinned 100 flake. If the crystal were monoclinic, then the unique axis would have to coincide either with the obtuse bisectrix or the optic normal, and the acute bisectrix should then display either horizontal or inclined dispersion. Instead, one sees a combination of inconsistent effects upon rotation of the stage. This means that the dispersion is asymmetric and the crystal triclinic.

Scanning electron microscope (SEM). During a recent investigation of twinning in orthorhombic KNbO₃ (to be reported elsewhere), one of us (A.B.C.) discovered a new method of visualizing polarity in crystals.

When flat and continuous faces of KNbO₃ that had not received the usual conductive coating were viewed in the scanning electron microscope in the secondary electron mode, contrast differences arose between adjacent areas due to differential charging by the electron beam. We were able to demonstrate that the contrasting areas correspond to ferroelectric domains.

It is not necessary for a polar crystal to be strongly ferroelectric to exhibit this effect. The contrast could be readily seen on 001 and $00\bar{1}$ faces, lying side by side, of BeO twins of the polarity reversal type. Nonpolar crystals do not show this effect.

The method was used to view the $\bar{2}01$ and $20\bar{1}$ faces, again lying side by side, of a "kite" twin of β -Ga₂O₃, and contrast was observed. This would not be possible if the faces were equivalent. It is evidence for the noncentrosymmetric nature of the compound.

Second-harmonic generation (SHG). In recent years, the optical generation of second-harmonic radiation has emerged as perhaps the most sensitive test available for detecting the absence of a center of symmetry. As in all other such tests, a negative result is not conclusive, but SHG approaches this goal with a success rate of 98% or better (4, 5). We prevailed upon Dr. Kurtz and Dr. Dougherty at the Philips Laboratories to test β -Ga₂O₃ for second-harmonic generation. The results were negative. Dr. Abrahams at the Bell Telephone Laboratories was kind enough to measure the pyroelectric coefficient dP/dT and found it to be not detectable.

Conclusions

The failure of the SHG test cannot modify our conclusions. By definition, the symmetry of a crystal cannot be higher than the lowest symmetry of any of its properties. The optics point to the triclinic system, SEM observations and the existence of enantiomorphs prove the absence of a center of symmetry, and the morphological point group is 1.

One cannot say with certainty what this implies for the structure reported by Geller. There is reason to believe that the structure is essentially correct, but that the positional

parameters were not determined with high enough precision to recognize small departures from the positions that would be equivalent in space group $C/2m$. That the low symmetry of β -Ga₂O₃ manifests itself only in certain observations but is not evident in such normally sensitive tests as SHG and pyroelectricity must be connected with its severe pseudosymmetry. The latter will be taken up briefly once more in the Appendix.

The special interest in the results reported here lies in the fact that they make β -Ga₂O₃ the least symmetrical of all simple oxides, it being the only one for which space group $P1$ has been established.

Appendix. The Oxygen Sublattice and Pseudosymmetry

Since the oxygen radius is more than twice the gallium radius, the structure is based on an oxygen framework, even though the unit cell volume is larger than would be expected for a close-packed structure. The departure of an oxygen sublattice from cubic or hexagonal symmetry should be moderate at most.

No indication of three- or sixfold pseudosymmetry was observed, even though gallium oxide has a metastable, low-temperature polymorph with the corundum structure, the α -form. However, the partial list of pseudocells in Table I contains many rectangular cells and in particular a large cubic one. There is yet another, closely related, cubic ($23.8 \times 25.2 \times 25.2$ Å) pseudocell which appears to have even more relevance to the oxygen framework. It is $06\bar{3}/063/201$. The inverse matrix is $1\bar{1}6/110/\bar{2}20$. If one transforms the indices of planes and axes that are significant for the twinning to this cell, it is seen that the nature and

TABLE III

Pseudomonoclinic	Pseudocubic
(100)	(001)
($\bar{1}12$)	(100)
(10 $\bar{2}$)	($\bar{1}10$)
(512)	(011)
($\bar{5}\bar{1}2$)	($\bar{1}01$)
(20 $\bar{1}$)	($\bar{1}\bar{1}1$)
($\bar{2}01$)	($\bar{1}\bar{1}\bar{1}$)
(310)	(111)
[001]	[$\bar{1}10$]
[021]	[010]
[132]	[011]
[$\bar{1}32$]	[$\bar{1}01$]

simplicity of the resulting indices, shown in Table III, attest to the relevance of this pseudocell to the twinning of β -Ga₂O₃. In addition, the large faces of the kite and delta wing twins, ($\bar{2}01$) and (310), respectively, become cubic octahedral faces of the type {111}.

Acknowledgment

We are indebted to our several anonymous referees for major efforts which contributed importantly to the final form of this work.

References

1. S. GELLER, *J. Chem. Phys.* **33**, 676 (1960).
2. B. GRUBER, *Acta Crystallogr.* **A26**, 622 (1970).
3. J. A. KOHN, G. KATZ, AND J. D. BRODER, *Amer. Min.* **42**, 398 (1957).
4. S. K. KURTZ AND T. T. PERRY, *J. Appl. Phys.* **39**, 3798 (1968).
5. S. K. KURTZ, "Ninth International Congress of Crystallography," Collected Abstracts, S231 (1972).
6. G. M. WOLTEN, *Acta Crystallogr.* **A28**, 213 (1972).