

Crystal Structure of $\text{Mg}_2(\text{OH})_2\text{CO}_3$, Deduced from the Topotactic Thermal Decomposition of Artinite

J. R. GÜNTER AND H. R. OSWALD

Anorganisch-chemisches Institut der Universität, Rämistrasse 76, CH-8001 Zürich, Switzerland

Received January 6, 1977

By means of single-crystal X-ray diffraction of nondecomposed, partly, and fully decomposed artinite ($\text{Mg}_2(\text{OH})_2\text{CO}_3 \cdot 3\text{H}_2\text{O}$), it has been shown that the intermediate product of decomposition, $\text{Mg}_2(\text{OH})_2\text{CO}_3$, is not amorphous. Its unit cell has been determined and a model of its structure has been deduced, which can account for both the lattice parameters and the relative orientations of the unit cells of artinite, intermediate product, and magnesium oxide found experimentally. The decomposition reaction can be described as a topotactic process with conservation of chains in both and additional conservation of layers in the second step.

Introduction

A chemical reaction of a solid is called topotactic, if its product is formed in one or several crystallographically equivalent defined orientations relative to the parent crystal and if the reaction can proceed throughout the entire volume of the initial crystal.

On the basis of a large number of experimental results on topotactic reactions, a systematic classification scheme has recently been proposed (1). Topotactic processes are divided into five groups, according to their mechanism of nucleation:

1. conservation of three-dimensional elements of the initial structure,
2. conservation of two-dimensional elements (layers),
3. conservation of one-dimensional elements (chains),
4. epitactic nucleation on inner lattice planes of the decomposing crystal,
5. epitactic nucleation on external surfaces.

The concept of this classification has, furthermore, successfully been used to elucidate unknown crystal structures of compounds in-

volved in topotactic dehydration reactions (2, 3).

However, the results on the decomposition of the mineral artinite, $\text{Mg}_2(\text{OH})_2\text{CO}_3 \cdot 3\text{H}_2\text{O}$, presented by Iwai *et al.* (4) are not compatible with the above concept. They found that the final product of artinite decomposition is highly oriented magnesium oxide, although the reaction apparently proceeds over an X-ray amorphous intermediate of the formula $\text{Mg}_2(\text{OH})_2\text{CO}_3$. In such a case, the high degree of orientation of MgO , i.e., the topotaxy of the overall process, could be accounted for neither by conservation of three-, two-, or one-dimensional structural elements nor by epitactic nucleation. Therefore, the decomposition of artinite was reinvestigated by thermal analysis and X-ray diffraction, with special attention to the crystallinity and eventual crystal structure of the intermediate product, $\text{Mg}_2(\text{OH})_2\text{CO}_3$.

Experimental Methods

The artinite crystals used were minerals from two different locations (Monte Motta, Valtellina, Italy, and Emarese, Val d'Aosta, Italy).

The thermal decomposition was investigated by means of a Mettler Thermoanalyzer TA 1

in flowing argon, with heating rates of 1.5 and 4°C/min; X-ray diffraction experiments were performed on a Weissenberg camera with $\text{CuK}\alpha$ radiation and on a Precession camera with $\text{MoK}\alpha$ radiation. The decomposition of single crystals was induced by heating the oriented crystals on their goniometer supports without changing their orientation.

Results

In good agreement with Iwai *et al.* (4), the thermogravimetric decomposition curves show two distinct steps at 190–250 and 320–400°C, respectively. The weight losses correspond to the reactions

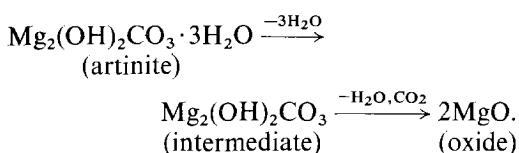

(Throughout the following text, abbreviations a = artinite, i = intermediate, o = oxide will be used.)

Weissenberg and rotation photographs of the artinite crystals confirm the structural data of De Wolff (5) and Jagodzinski (6), indicating a disordered monoclinic structure with $a = 16.561 \text{ \AA}$, $b = 6.298 \text{ \AA}$, $c = 6.220 \text{ \AA}$, $\beta = 99.9^\circ$ (pronounced subcell a , $b/2$, c , space group $C2$). The needle axis of the crystals is b .

After heating to 230°C for 2 hr, such crystals yield single crystal diffraction patterns with extremely faint and diffuse but still distinct reflections, the original artinite pattern having completely disappeared. With prolonged exposure times (up to 72 hr), the diagrams become sufficiently intense to be indexed. Thus the unit cell of the intermediate, $\text{Mg}_2(\text{OH})_2\text{CO}_3$, and its relative orientation to artinite can be determined, proving at the same time a certain degree of crystallinity of the compound: Unit cell of $\text{Mg}_2(\text{OH})_2\text{CO}_3$ (i): monoclinic: $a = 9.34 \text{ \AA}$, $b = 3.15 \text{ \AA}$, $c = 12.18 \text{ \AA}$, $\beta = 90^\circ$.

Although the unit cell is rectangular within the error of measurement, the obvious intensity difference between (102) and $(1\bar{0}2)$ reflections implies monoclinic symmetry. Observed diffraction criteria: $hk0$ only with h

even ($h00$ only with h even), $00l$ only with l even.

The first of these criteria is not compatible with any of the monoclinic space groups. However, such observations are common in heavily disordered or twinned crystals. The orientation of $\text{Mg}_2(\text{OH})_2\text{CO}_3$ (i) relative to artinite (a): in reciprocal space: $[100]_i \parallel [100]_a$ and $[010]_i \parallel [010]_a$, corresponding in real space to: $(100)_i \parallel (100)_a$ and $[010]_i \parallel [010]_a$.

It should be noted that the respective b axes of artinite and intermediate not only remain parallel, but also change very little in length, from $b_a = 3.149 \text{ \AA}$ ($\times 2$) to $b_i = 3.15 \text{ \AA}$.

The X-ray diffraction patterns of the totally decomposed pseudomorphs (heated to 350°C for 2 hr) again agree well with the data of Iwai *et al.* (4) and can be attributed to cubic MgO with $a_o = 4.212 \text{ \AA}$ (7).

$[110]_o$ runs parallel to the needle axis ($d_{110o} = 2.98 \text{ \AA}$) and $[001]_o$ includes an angle of 22° with $[001]_a$. The latter relation is only approximate, as the individual microcrystallites of MgO are tilted up to $\pm 10^\circ$ about their common axis, leading to an appreciable elongation of the Weissenberg reflections, as illustrated in (4). These relative orientation relations between a , i , and o unit cells are illustrated in Fig. 1.

The decomposition of artinite is not reversible even in its first steps, as crystals of the intermediate, immersed in water for several

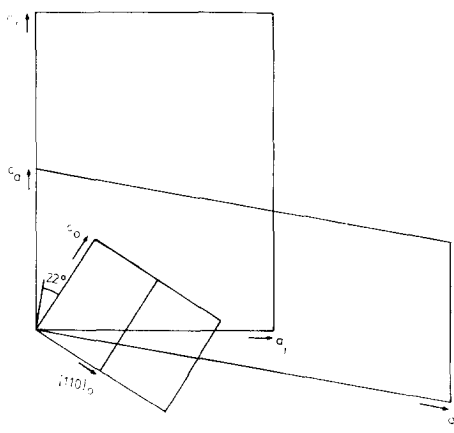

FIG. 1. Relative orientation relations between the unit cells of artinite (a), intermediate (i) and magnesium oxide (o), as found experimentally.

hours, show Weissenberg diffraction patterns identical with those of crystals not treated with water. Experimental results for artinite minerals from both locations are identical.

Deduction of the Crystal Structure of $Mg_2(OH)_2CO_3$

As in the case of yellow molybdenum trioxide monohydrate (2), we attempt to deduce the principal features of the unknown intermediate product structure of a two-step decomposition from the known educt and product structures and their relative orientations found experimentally. The validity of this kind of deduction has been proved earlier (3). For comparison, the structure of artinite (5, 6) must be described first.

Artinite is built up from infinite double chains of edge-sharing octahedra $[Mg(OH)_3(H_2O, CO_3)_1(H_2O)_2]_{\infty}$ parallel to $[010]$ (Fig. 2). The chains are linked by hydrogen bonds from crystal water molecules to terminal carbonate groups in neighboring chains. While all corners shared by three octahedra are occupied by hydroxide ions and all corners shared by only two octahedra are occupied by water molecules, the terminal nonshared corners within one and the same chain are occupied alternately by water molecules and carbonate ions.

If the arrangement of the individual chains relative to each other is considered to be strictly ordered, the substructure described by De Wolff (5) is obtained. However, in real artinite crystals the chains are disordered, being

shifted parallel to each other along $[010]$, thus producing the structure determined by Jagodzinski (6).

From the knowledge of the artinite structure and the topotactic orientation relations, one can now attempt to deduce the unknown crystal structure of the intermediate $Mg_2(OH)_2CO_3$. As a check on these arguments, the deduced structure must allow an easy interpretation of the second step of decomposition to the known magnesium oxide lattice in the experimentally found orientation.

As chemical reactions in solids occur in such a way that the number of strong bonds being broken is minimal and the diffusion paths of atoms are as short as possible, it follows that in the first step of decomposition, the loss of three molecules of water per formula unit, the water molecules liberated are those already present as H_2O , the OH^- ions remaining unaffected at this stage of the reaction. This leaves a hypothetical incomplete structure with active empty sites at the nonoccupied corners of octahedra (Fig. 3), which must be refilled by condensation of chains.

If octahedral coordination of Mg^{2+} and the equivalence of all cations are to persist, the stoichiometry of $Mg_2(OH)_2CO_3$ allows only one kind of octahedral composition: $[Mg(OH)_5(CO_3)_{1/2}]$. This can be obtained, if the incomplete chains described above condense in such a way that all empty corners which were originally shared by two octahedra interact with an OH^- ion of a neighboring chain, and the empty terminal corners are filled by an

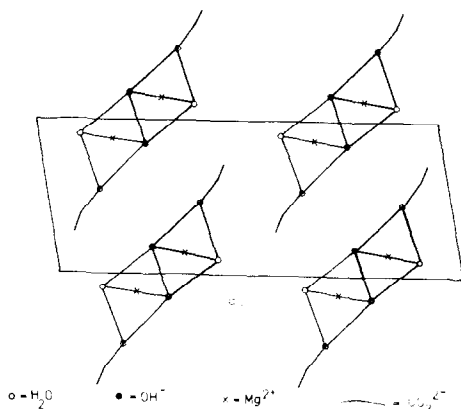

FIG. 2. Projection $[010]$ of the artinite structure.

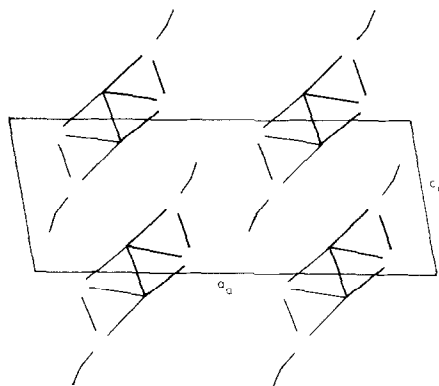

FIG. 3. Projection $[010]$ of a hypothetical dehydrated artinite structure prior to rearrangement of the lattice.

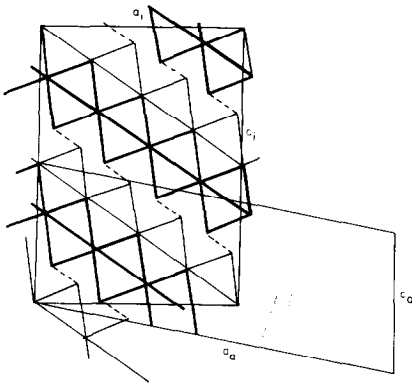

FIG. 4. Projection [010] of the proposed crystal structure of $\text{Mg}_2(\text{OH})_2\text{CO}_3$ (i).

O atom of a neighboring carbonate group, the latter becoming a carbonate bridge. To achieve this, the chains of the artinite structure must be shifted along [010] in order to bring the corresponding vacancies and ions to neighboring positions.

Figure 4 illustrates the structure of the intermediate after completion of the first reaction step (loss of $3\text{H}_2\text{O}$ per formula unit), in the correct relative orientation to artinite as requested by the experimentally found topotactic orientation relation. The necessity of a shift prior to condensation of chains accounts for the high degree of disorder in the crystals of this intermediate product. At the same time it implies that the number of nuclei formed is high, leading to a large number of consequently small crystallites. The therefore heavily faulted crystal aggregate accounts for the difficulties

in registering X-ray diffraction patterns in the experiments of Iwai *et al.* (4) as well as for the impossibility of assigning a space group to the intermediate in the present work.

The crystal structure of $\text{Mg}_2(\text{OH})_2\text{CO}_3$ thus consists of double layers of $[\text{Mg}(\text{OH})_5(\text{CO}_3)_{1/2}]$ octahedra parallel to $(102)_i$, adjacent layers being connected by bridging carbonate groups. The orientation of these layers explains qualitatively the intensity differences of $(102)_i$ and $(10\bar{2})_i$ reflections referred to above.

The individual double layers may be considered as slabs cut from a cubic close-packed OH^- arrangement with magnesium ions in the octahedral interstices and with terminal carbonate ions. Such cubic close-packed oxygen slabs may also be looked at as precursors of the MgO structure to be formed on further decomposition. They are easily converted into the latter by loss of H_2O and CO_2 parallel to the interlayer spacings and subsequent collapse of the remaining slabs to a three-dimensional cubic close-packed arrangement of O^{2-} ions with Mg^{2+} in all octahedral interstices, i.e., the magnesium oxide lattice. The displacement of the layers required for this step is the smallest possible, as no rotation at all is required. Not only is the structure of MgO easily obtained from the model structure of $\text{Mg}_2(\text{OH})_2\text{CO}_3$, but it is also in its correct orientation with respect to artinite ($[110]_o$ parallel to $[010]_a$) (compare with Fig. 1). The final magnesium oxide structure is represented by Fig. 5 in its relative position to the unit cells of artinite and $\text{Mg}_2(\text{OH})_2\text{CO}_3$.

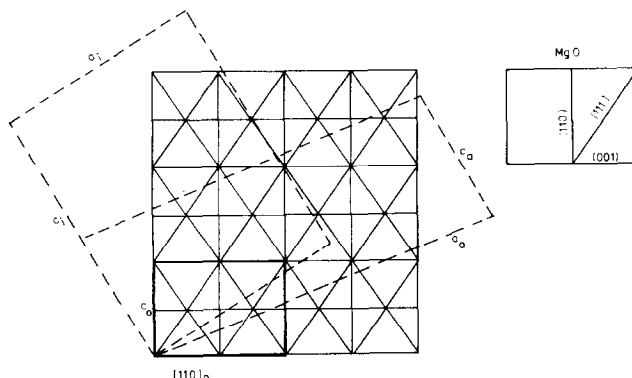

FIG. 5. Projection $[1\bar{1}0]$ of the magnesium oxide structure in its proper relative orientation to the unit cells of artinite and intermediate.

Throughout both steps of decomposition, the zig-zag chains $\text{Mg-O-Mg-O}\cdots$ parallel to b_a have remained almost unaffected, being conserved as chains in the first step and as integral parts of layers in the second.

The analogy of $\text{Mg}_2(\text{OH})_2\text{CO}_3$ with the well-known mineral malachite, $\text{Cu}_2(\text{OH})_2\text{CO}_3$, both in composition and in lattice constants (malachite: $a = 9.502 \text{ \AA}$, $b = 11.974 \text{ \AA}$, $c = 3.240 \text{ \AA}$, $\beta = 98.75^\circ$ (8)) might imply a possibly high similarity of the crystal structures. However, the malachite crystals contain two nonequivalent sets of copper ions in 4 + 2 distorted octahedral surroundings of the compositions $[\text{Cu}(\text{OH})_4(\text{CO}_3)_2]_4$ and $[\text{Cu}(\text{OH})_2(\text{CO}_3)_2]_2$.

To obtain a similar structure by dehydration of artinite, which has only one kind of cation with maximally one carbonate ion per octahedron, a complete rearrangement of the anions would have to occur. This is not compatible with the requirements for a topotactic reaction that the number of strong bonds to be broken and the lengths of the diffusion paths are minimal. Therefore, a malachite-

type structure for dehydrated artinite must be ruled out.

Acknowledgments

The authors thank Dr. W. Oberholzer (ETH Zürich) for the artinite crystals from Monte Motta and the "Schweizerischer Nationalfonds zur Förderung der wissenschaftlichen Forschung" for financial support.

References

1. J. R. GÜNTER AND H. R. OSWALD, *Bull. Inst. Chem. Res. Kyoto Univ.* **53**, 249 (1975).
2. J. R. GÜNTER, *J. Solid State Chem.* **5**, 354 (1972).
3. H. R. OSWALD, J. R. GÜNTER, AND E. DUBLER, *J. Solid State Chem.* **13**, 330 (1975).
4. S. IWAI, H. AOKI, T. SHIMAMUNE, AND H. MORIKAWA, *Amer. Mineral.* **55**, 1055 (1970).
5. P. M. DE WOLFF, *Acta Crystallogr.* **5**, 286 (1952).
6. H. JAGODZINSKI, *Mineral. Petrog. Mitt.* **10**, 297 (1965).
7. R. A. BROWN, *Nature* **208**, 481 (1965).
8. P. SÜSSE, *Acta Crystallogr.* **22**, 146 (1967).