

## Neutron and X-Ray Diffraction Structure Determination of $\text{Cs}_2[\text{VOF}_4(\text{H}_2\text{O})]$ , a Compound Previously Assigned $\text{Cs}_2\text{VF}_6$ Composition

KJELL WALTERSSON

*Department of Inorganic Chemistry, Arrhenius Laboratory, University of Stockholm, S-106 91 Stockholm, Sweden*

Received May 17, 1978, in revised form October 12, 1978

The crystal structure of  $\text{Cs}_2[\text{VOF}_4(\text{H}_2\text{O})]$  has been studied on the basis of three-dimensional neutron and X-ray diffraction data. The structure is orthorhombic;  $a = 15.251(2)$ ,  $b = 6.486(1)$ , and  $c = 7.010(1)$  Å;  $Z = 4$ ;  $V = 693.46$  Å<sup>3</sup>; space group *Ccmm* (No. 63). From the neutron data the positions of all atomic species except vanadium were refined. The final  $R_w$  value was 0.030 for 427 independent reflections with  $\sigma(I)/I \leq 0.60$ . In the X-ray case the positions of nonhydrogen atoms were refined. The final  $R_w$  value was 0.022 for 509 observations with  $\sigma(I)/I \leq 0.40$ . The structure contains strongly deformed octahedral complex ions  $[\text{VOF}_4(\text{H}_2\text{O})]^{2-}$ , held together by hydrogen bonds O-H...F (forming chains in the *c* direction) with cesium atoms inserted between them. The vanadyl ion  $\text{VO}^{2+}$  (V-O bond distance 1.602(8) Å; X-ray value) is coordinated to four fluorine ligands and to one  $\text{H}_2\text{O}$  molecule in *trans* position to the vanadyl oxygen. The V-F and the V-O<sub>w</sub> distances are  $4 \times 1.919(4)$  and 2.268(8) Å, respectively; all are X-ray values. The O-H distance is 0.987(7) Å and the H-O<sub>w</sub>-H angle 105.1(9)°. The coordination numbers of the two crystallographically independent cesium atoms are 13 and 11, respectively.

### Introduction

The crystal structure of a compound given the formula  $\text{Cs}_2\text{VF}_6$  was reported a few years ago (1, 2). The structure was determined and refined from three-dimensional X-ray diffractometer data (MoK $\alpha$  radiation). The evidence for the stoichiometry  $\text{Cs}_2\text{VF}_6$  of the compound, a fluorine analysis with a specific ion electrode and the crystal structure refined to  $R_w = 0.030$ , was, however, not conclusive, and a fluorine analysis with another method was deemed desirable. This gave a fluorine content markedly different from the previous one, viz., 17.5 wt% instead of 26.46 wt% calculated for  $\text{Cs}_2\text{VF}_6$ . A thermogravimetric study of the compound and new ir data gave support for revision of the formula of the compound to  $\text{Cs}_2[\text{VOF}_4(\text{H}_2\text{O})]$ .

The single-crystal neutron diffraction study of the compound reported in this paper has proved the revision of the stoichiometry to be correct.

### Experimental

#### *Preparation and Characterization*

Mixtures of divanadium pentoxide (Fisher p.a.) and pure divanadium trioxide (obtained by reduction of  $\text{V}_2\text{O}_5$  with hydrogen) in the mole ratio 1:1 were added to different amounts of cesium carbonate (Merck p.a.) and dissolved in 40% HF. In all preparations, the pH value of the resulting solution was less than 2. When the Cs/V ratio was 2 the crystallization produced  $\text{Cs}_3\text{V}_2\text{O}_2\text{F}_7$  (3, 4, 19), and for  $\text{Cs}/\text{V} \geq 4$  the blue crystalline product was the compound previously given the formula  $\text{Cs}_2\text{VF}_6$ .

The cesium and vanadium contents of the latter compound were determined with an atomic absorption instrument. The Cs/V ratio was found to be close to 2.

The amount of fluorine in the sample was determined with the method described by Willard and Winter (5). The fluorine content was found to be 17.5 wt% instead of 26.46 wt% calculated for  $\text{Cs}_2\text{VF}_6$ . Furthermore, a thermogravimetric study of the compound was performed. At 115°C a

weight loss of 4.1% was observed. A sample was also heated carefully in a dry glass tube. Small drops of water appeared in the cold part of the tube, which established the nature of the volatile product.

The ir spectrum between 500 and 3800  $\text{cm}^{-1}$  was recorded by a double-beam instrument. The spectrum is presented in Fig. 1. The broad absorption band at  $\sim 3500 \text{ cm}^{-1}$  is interpreted as belonging to the stretching vibration of an OH group or  $\text{H}_2\text{O}$  molecule. A sharp absorption band at

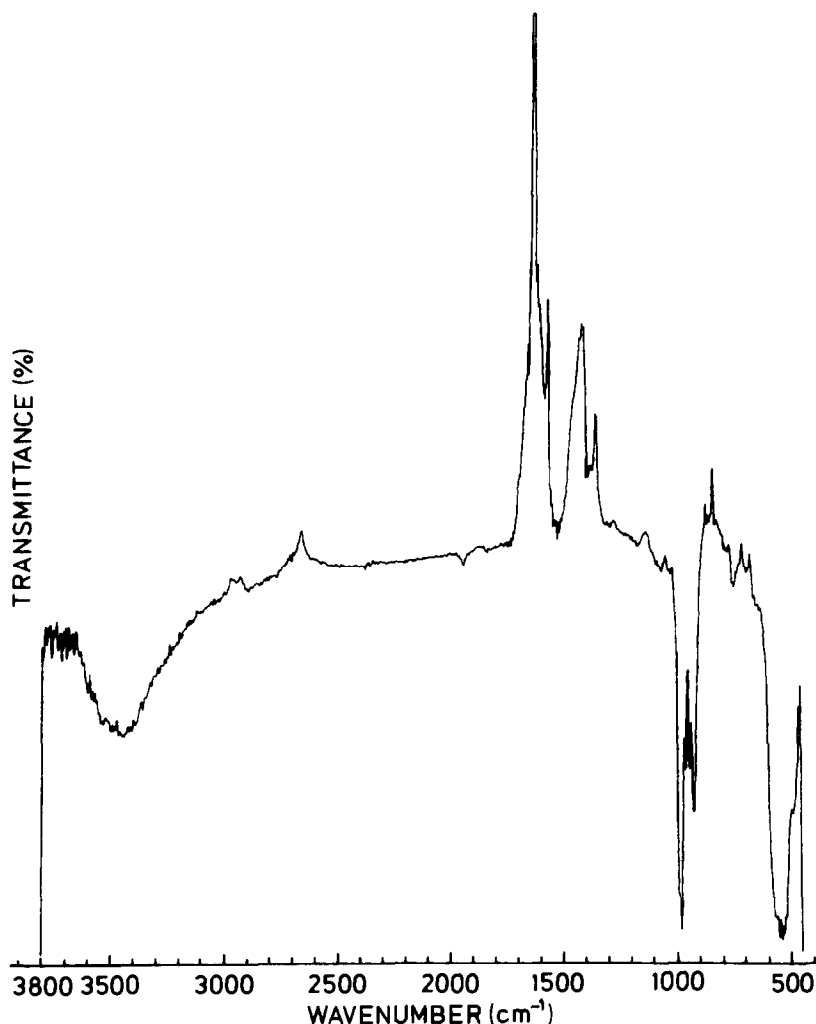

FIG. 1. The ir spectrum of  $\text{Cs}_2[\text{VOF}_4(\text{H}_2\text{O})]$  between 500 and 3800  $\text{cm}^{-1}$ , recorded by a double-beam instrument.

$1630\text{ cm}^{-1}$  is assigned to the bending mode of  $\text{H}_2\text{O}$ .

The magnetic susceptibility measurements, carried out by the Faraday method over the range 78 to 270°K, confirmed the oxidation number of the vanadium atoms to be +4. The observed magnetic moment,  $1.67\ \mu_{\text{B}}$ , was in fair agreement with the expected value,  $1.73\ \mu_{\text{B}}$ , for  $\text{V}^{4+}$  (see Fig. 2).

Thus the observed fluorine content, the magnetic susceptibility measurements, and the TGA analysis are in accord with the formula  $\text{Cs}_2[\text{VOF}_4(\text{H}_2\text{O})]$ : F observed 17.5 wt%, calculated 17.8 wt%;  $\text{H}_2\text{O}$  observed 4.1 wt%, calculated 4.22 wt%.

### Crystal Data and Data Collection

#### X-Ray Data

X-Ray powder patterns of the compound were recorded by means of a Guinier-Hägg focusing camera using  $\text{CuK}\alpha_1$  radiation ( $\lambda = 1.54051\ \text{\AA}$ ) and KCl ( $a = 6.2930\ \text{\AA}$ ) as internal standard (7). Least-squares

refinement of the lattice constants led to excellent agreement with the results published earlier, viz.,  $a = 15.251(2)$ ,  $b = 6.486(1)$ , and  $c = 7.010(1)\ \text{\AA}$ . No extra reflection lines were detected. The powder pattern is given in Table I.

TABLE I  
POWDER PATTERN OF  $\text{Cs}_2[\text{VOF}_4(\text{H}_2\text{O})]^a$

| <i>h</i> | <i>k</i> | <i>l</i> | $d_{\text{obs}}$ | $10^5 \times \sin^2 \theta_{\text{obs}}$ | $10^5 \times \sin^2 \theta_{\text{calc}}$ | $I_{\text{obs}}$ |
|----------|----------|----------|------------------|--|---|------------------|
| 1        | 1        | 0        | 5.978            | 1660                                     | 1665                                      | m                |
| 1        | 1        | 1        | 4.548            | 2869                                     | 2872                                      | w                |
| 3        | 1        | 0        | 4.002            | 3705                                     | 3706                                      | s                |
| 4        | 0        | 0        | 3.809            | 4090                                     | 4081                                      | vw               |
| 0        | 0        | 2        | 3.508            | 4822                                     | 4829                                      | vs               |
| 3        | 1        | 1        | 3.477            | 4908                                     | 4913                                      | vs               |
| 4        | 0        | 1        | 3.350            | 5286                                     | 5288                                      | s                |
| 0        | 2        | 0        | 3.246            | 5631                                     | 5641                                      | s                |
| 1        | 1        | 2        | 3.021            | 6501                                     | 6494                                      | m                |
| 2        | 2        | 1        | 2.746            | 7868                                     | 7868                                      | vw               |
| 3        | 1        | 2        | 2.635            | 8546                                     | 8535                                      | m                |
| 4        | 0        | 2        | 2.581            | 8906                                     | 8910                                      | s                |
| 6        | 0        | 0        | 2.542            | 9183                                     | 9183                                      | m                |
| 4        | 2        | 0        | 2.470            | 9722                                     | 9722                                      | s                |
| 6        | 0        | 1        | 2.3880           | 10404                                    | 10390                                     | m                |
| 0        | 2        | 2        | 2.3801           | 10473                                    | 10470                                     | vs               |
| 4        | 2        | 1        | 2.3291           | 10937                                    | 10929                                     | m                |
| 1        | 3        | 0        | 2.1403           | 12951                                    | 12946                                     | vw               |
| 6        | 0        | 2        | 2.0571           | 14020                                    | 14012                                     | vw               |
| 3        | 1        | 3        | 2.0184           | 14563                                    | 14572                                     | s                |
| 4        | 0        | 3        | 1.9915           | 14959                                    | 14947                                     | m                |
| 7        | 1        | 1        | 1.9812           | 15115                                    | 15116                                     | m                |
| 6        | 2        | 1        | 1.9242           | 16024                                    | 16031                                     | w                |
| 3        | 3        | 1        | 1.9144           | 16189                                    | 16194                                     | m                |
| 8        | 0        | 1        | 1.8399           | 17525                                    | 17532                                     | vw               |
| 7        | 1        | 2        | 1.7790           | 18746                                    | 18738                                     | vw               |
| 0        | 0        | 4        | 1.7517           | 19336                                    | 19317                                     | m                |
| 6        | 2        | 2        | 1.7386           | 19628                                    | 19652                                     | w                |
| 4        | 2        | 3        | 1.6980           | 20577                                    | 20588                                     | vw               |
| 9        | 1        | 0        | 1.6387           | 22095                                    | 22071                                     | vw               |
| 7        | 1        | 3        | 1.5479           | 24762                                    | 24775                                     | w                |
| 0        | 2        | 4        | 1.5420           | 24951                                    | 24958                                     | w                |
| 6        | 2        | 3        | 1.5199           | 25681                                    | 25689                                     | w                |
| 3        | 3        | 3        | 1.5151           | 25845                                    | 25852                                     | w                |
| 7        | 3        | 1        | 1.4991           | 26401                                    | 26397                                     | vw               |
| 0        | 4        | 2        | 1.4712           | 27411                                    | 27392                                     | vw               |
| 10       | 0        | 2        | 1.3984           | 30338                                    | 30337                                     | w                |
| 10       | 2        | 0        | 1.3803           | 31141                                    | 31148                                     | vw               |
| 3        | 1        | 5        | 1.3231           | 33892                                    | 33888                                     | m                |

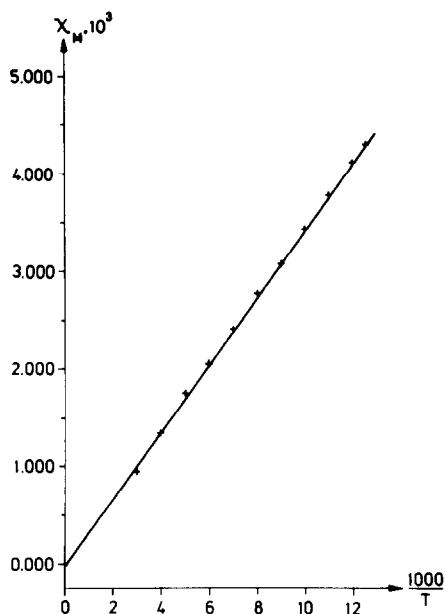

FIG. 2. The magnetic susceptibility measured by the Faraday method. Slope  $c = 0.344$ ;  $\mu_{\text{eff}} = 2.84c^{1/2}\ \mu_{\text{B}}$ ;  $\mu_{\text{eff}} = 1.67\ \mu_{\text{B}}$ .

<sup>a</sup>  $\text{CuK}\alpha_1$  radiation ( $\lambda = 1.54051\ \text{\AA}$ ); internal standard KCl ( $a = 6.2930\ \text{\AA}$ ).

A crystal with  $3.8 \times 10^{-4} \text{ mm}^3$  volume was selected and mounted along the  $b$  axis on a Siemens AED diffractometer. Nb-filtered  $\text{MoK}\alpha$  radiation, the  $\theta$ - $2\theta$  scan technique, and the five-point measuring procedure were used for the X-ray data collection. All the 588 possible lattice points, systematic extinctions excluded, up to  $30^\circ$  were measured. Of these, 509 were judged significant from the criterion  $\sigma(I)/I \leq 0.40$ , where  $\sigma(I) = (I_t + I_b)^{1/2}$  and  $I = I_t - I_b$ . Lorentz polarization and absorption corrections ( $\mu = 119 \text{ cm}^{-1}$ ) were applied to the data.

### Neutron Data

A well-shaped prismatic crystal with the volume  $9.4 \text{ mm}^3$  was selected. Preliminary investigations by means of polarization microscopy, oscillation, and Weissenberg photographs proved it to be useful for neutron diffraction work. The neutron data were collected at  $\sim 25^\circ\text{C}$  at the Studsvik R2 reactor.

The procedure of the data collection is described in detail by Tellgren *et al.* (8). The crystal was mounted along the prism axis ( $b$ ).

The  $\omega$ -scan technique was applied. The neutron wavelength was  $1.210 \text{ \AA}$ . The integrated intensities were measured for all the 1164 independent lattice points with  $\theta \leq 57^\circ$  within one octant of the observable reciprocal lattice sphere. The intensity measurements for the individual lattice points were performed by 40 scanning steps for  $\theta \leq 40^\circ$  and by 45 steps for  $40^\circ \leq \theta \leq 57^\circ$ . The step length was  $0.05^\circ$ . Three standard reflections were automatically monitored throughout the data collection, indicating no deterioration of the crystal.

A check of the intensity data established that the systematic extinctions were the same as for the X-ray data, viz.,  $hkl$ ,  $h+k = 2n+1$ ; and  $0kl$ ,  $l = 2n+1$ . Of the remaining 565 lattice points 427 reflections with  $\sigma(I_n)/I_n \leq 0.60$  were used in the refinement. The net intensity,  $I_n$ , was calculated as  $I_t - I_b$ ,

where  $I_b$  is scaled to the same measuring level as  $I_t$ . The estimated standard deviations were obtained from the expression  $\sigma(I_n) = (I_t + I_b)^{1/2}$ , where  $I_t$  and  $I_b$  are the total and background intensities, respectively.

The data were then corrected for Lorentz, polarization, and absorption effects. The experimentally determined linear absorption coefficient,  $\mu_{\text{obs}} = 0.81 \text{ cm}^{-1}$ , was used in calculating a transmission factor for each reflection. The observed absorption coefficient is several times larger than the theoretical value of  $\mu_{\text{calc}} = 0.21 \text{ cm}^{-1}$  ( $\lambda = 1.08 \text{ \AA}$ ) (9). This discrepancy between  $\mu_{\text{obs}}$  and  $\mu_{\text{calc}}$  is explained by incoherent scattering by the hydrogen atoms, which is estimated to be  $\sigma(\text{abs})_{\text{incoh}} = 52 \times 10^{-24} \text{ cm}^2$ .

The transmission was estimated by the Gaussian integration method with  $10 \times 12 \times 10$  grid points. The factor  $A$  in the formula  $I = Lp \cdot I_n/A$  ranged from 0.8518 to 0.8850.

The calculations were performed on IBM 1800 and IBM 360/75 computers.

### Refinement

From the systematic extinctions, mentioned above, the space groups  $Ccmm$  (No. 63),  $Cc2m$  (No. 40), and  $Ccm2_1$  (No. 36) were possible.

An initial three-dimensional  $F_{\text{obs},N}$  synthesis was calculated in the centric space group  $Ccmm$ , with signs given by the atomic positions previously reported for this compound (2). The  $R$  value at this stage was 0.19. Two negative areas were observed at a distance of  $0.9 \text{ \AA}$  from the ligand with the longest vanadium-ligand distance (viz.,  $2.29 \text{ \AA}$ ). The ligand was identified as a water molecule. Both of the negative areas had their minima  $0.4 \text{ \AA}$  out of the mirror plane, perpendicular to the  $b$  axis, generating four minima related to each other by the two orthogonal mirror planes.

The refinement was started with the assumption that the structure was centric (space group  $Ccmm$ ). With a full-matrix least-squares program a hydrogen position in

point set 8(f) was now refined together with the atoms given by the X-ray study. The refinement was continued with anisotropic temperature factors and anisotropic extinction corrections included, giving an  $R_w$  value of 0.036, but resulting in a very high  $\beta_{22}$  factor ( $\sim 0.12$ ) for the hydrogen atom. Therefore it was assumed that the hydrogens were situated in positions on both sides of the mirror plane orthogonal to the  $b$  axis. These hydrogen positions with half occupancy in point set 16(h) of the space group  $Ccmm$  were refined, giving positions 0.4 Å out of the mirror plane. At the same time the  $\beta_{22}$  factor of the hydrogen atom dropped to a quite normal magnitude.

In an attempt to refine the occupancy factors for the two hydrogen sites on each side of the mirror plane the calculations were continued in the acentric space group  $Cc2m$ , with the nonhydrogen atoms kept in a restrained model with centric positions. This assumption was based upon the results obtained by the X-ray data (see below). The coordinates and anisotropic temperature factors of the two hydrogen sites were restricted by the mirror plane perpendicular to  $b$  present in space group  $Ccmm$ . The occupancy factors were refined with the assumption that the sum should be equal to 1 for the two positions. These refinements converged very slowly to a distribution of 0.67(2) and 0.33(2) for the two sites. The  $R_w$  value was 0.0298. Refinements of models with equal distributions of hydrogens in the two positions, as well as with full occupancy in one of the two sites, resulted in  $R_w$  values of 0.0302 and 0.0324, respectively. As judged from the nonhydrogen atom model, a hydrogen-bond system with the hydrogens equally distributed in the two sites seems to be more likely than a partly ordered system. So far no explanation has been found why a partly ordered model with 67% of all the  $\text{H}_2\text{O}$  molecules orientated in the same direction should exist in the crystal. Since the  $R_w$  value for the hydrogen-bond system with

equal distributions of the hydrogens is just slightly higher than the  $R_w$  value for the partly ordered model, it is assumed that the former model is the most probable one.

In the final least-squares refinement there were 42 variables, including 10 positional parameters, 24 anisotropic temperature factors, 1 isotropic temperature factor, 1 scale factor, and 6 anisotropic extinction parameters. The positional parameter of the vanadium atom was taken from the X-ray determination and was kept fixed throughout the refinement, while the isotropic temperature factor was refined. The reason for doing this was the small scattering length of vanadium, resulting in an unreasonably large uncertainty in the vanadium position, compared with the X-ray work. No increase in the  $R_w$  value was detected.

The coherent neutron scattering lengths were taken from Bacon (10): Cs, 0.55; V,  $-0.05$ ; O, 0.580; F, 0.56; and H,  $-0.374 \times 10^{-12}$  cm. The quantity minimized in the least-squares refinement was  $\sum w(|F_o| - |F_c|)^2$ . Statistical weights were applied to the structure factors:  $w = 1/\sigma^2(F_o)$ .

In a final three-dimensional ( $F_{\text{obs},N} - F_{\text{calc},N}$ ) synthesis there were only small residual maxima and minima.

The differences in positional parameters were less than  $2\sigma$  between the refinement in the space group  $Cc2m$  ( $R_w = 0.0216$ ; 509 observations and 54 variables), and that in the centric space group  $Ccmm$  ( $R_w = 0.0220$ ; 36 variables), both based on X-ray data. A significance test according to Hamilton (11) shows that the  $Ccmm$  model cannot be rejected even at a 25% significance level. Therefore the model of nonhydrogen atoms, derived from the X-ray data, could be regarded as centric.

The final positional and thermal parameters together with their estimated standard deviations, as well as the root-mean-square thermal displacements, are given in Table II. Also, the parameters from

TABLE IIa  
THE CRYSTAL STRUCTURE OF  $\text{Cs}_2[\text{VOF}_4(\text{H}_2\text{O})]^\text{a}$

| Atom ( <i>n</i> ) | Point set                   | Neutron positions  | X-Ray positions  |
|-------------------|-----------------------------|--|--|
| Cs(1)             | 4( <i>c</i> )               | $x = 0.24983(20)$<br>$y = 0$<br>$z = \frac{1}{4}$                                  | $x = 0.25025(5)$<br>$y = 0$<br>$z = \frac{1}{4}$             |
| Cs(2)             | 4( <i>c</i> )               | $x = 0.45152(22)$<br>$y = \frac{1}{2}$<br>$z = \frac{1}{4}$                        | $x = 0.45151(6)$<br>$y = \frac{1}{2}$<br>$z = \frac{1}{4}$   |
| V                 | 4( <i>c</i> )               | $x = 0.13022^\text{b}$<br>$y = \frac{1}{2}^\text{b}$<br>$z = \frac{1}{4}^\text{b}$ | $x = 0.13032(13)$<br>$y = \frac{1}{2}$<br>$z = \frac{1}{4}$  |
| O                 | 4( <i>c</i> )               | $x = 0.23664(19)$<br>$y = \frac{1}{2}$<br>$z = \frac{1}{4}$                        | $x = 0.23537(52)$<br>$y = \frac{1}{2}$<br>$z = \frac{1}{4}$  |
| F                 | 16( <i>h</i> )              | $x = 0.11158(21)$<br>$y = 0.29345(55)$<br>$z = 0.05786(39)$                        | $x = 0.11147(22)$<br>$y = 0.29320(54)$<br>$z = 0.05862(49)$  |
| O <sub>w</sub>    | 4( <i>c</i> )               | $x = -0.01970(18)$<br>$y = \frac{1}{2}$<br>$z = \frac{1}{4}$                       | $x = -0.01837(51)$<br>$y = \frac{1}{2}$<br>$z = \frac{1}{4}$ |
| H                 | 16( <i>h</i> ) <sup>c</sup> | $x = -0.04955(39)$<br>$y = 0.43968(134)$<br>$z = 0.13819(90)$                      | —<br>—<br>—  |

<sup>a</sup> MW = 426.78; space group, *Ccmm* (No. 63); cell dimensions,  $a = 15.251(2)$  Å,  $b = 6.486(1)$  Å,  $c = 7.010(1)$  Å, and  $V = 693.46$  Å<sup>3</sup>;  $D_{\text{calc}} = 4.088$  g cm<sup>-3</sup>,  $D_{\text{obs}} = 4.09$  g cm<sup>-3</sup> (2); cell content, 4  $\text{Cs}_2[\text{VOF}_4(\text{H}_2\text{O})]$ .

<sup>b</sup> From the X-ray data.

<sup>c</sup> Half occupancy.

the new X-ray refinements are included for comparison.

All the structural figures are pictorial representations of the thermal vibrations of the atoms. The thermal ellipsoids are drawn at 50% probability. The O<sub>w</sub>-H distances have been corrected for thermal motions, based on the riding-motion model. The most important distances and angles from both neutron and X-ray determination are included in Table III.

The V-X distances ( $X = \text{O}$ , F, or O<sub>w</sub>) determined from the neutron data have very low accuracy because of the small scattering length of  $-0.05 \times 10^{-12}$  cm for the V atoms.

Therefore the X-ray values are used for these distances in the following discussion.

### Description of the Structure

The structure is visualized in Fig. 3. The unit cell contains 8 cesium atoms, 4 vanadiums, 16 fluorines, 4 oxygens, and 4 water molecules. The crystal data are collected in Table II.

The vanadium octahedral coordination is pictured in Fig. 4. The vanadium is bonded to one oxygen by a double bond, the distance being 1.602(8) Å, forming a vanadyl ion, VO<sup>2+</sup>, to four fluorines by  $\sigma$  bonds ( $4 \times$

TABLE IIb

FINAL ANISOTROPIC TEMPERATURE FACTORS DEFINED AS  $\exp[-(\beta_{11} \cdot h^2 + \beta_{22} \cdot k^2 + \beta_{33} \cdot l^2 + 2\beta_{12} \cdot hk + 2\beta_{13} \cdot hl + 2\beta_{23} \cdot kl)]^a$ 

| Atom ( <i>n</i> ) | $\beta_{11}$           | $\beta_{22}$ | $\beta_{33}$ | $\beta_{12}$ | $\beta_{13}$ | $\beta_{23}$ | $R_1$ (Å) | $R_2$ (Å) | $R_3$ (Å) | $R$ (Å) |
|-------------------|------------------------|--------------|--------------|--------------|--------------|--------------|-----------|-----------|-----------|---------|
| Neutron data      |                        |              |              |              |              |              |           |           |           |         |
| Cs(1)             | 202(12)                | 1079(93)     | 1189(67)     | 0            | 0            | 0            | 0.152     | 0.154     | 0.172     | 0.276   |
| Cs(2)             | 254(13)                | 3378(159)    | 751(63)      | 0            | 0            | 0            | 0.137     | 0.173     | 0.268     | 0.347   |
| O                 | 144(10)                | 1436(104)    | 1288(69)     | 0            | 0            | 0            | 0.130     | 0.175     | 0.179     | 0.282   |
| F                 | 259(12)                | 2102(94)     | 1691(63)     | -56(34)      | -11(27)      | -1197(65)    | 0.124     | 0.176     | 0.267     | 0.343   |
| O <sub>w</sub>    | 137(10)                | 1410(98)     | 901(70)      | 0            | 0            | 0            | 0.127     | 0.150     | 0.173     | 0.262   |
| H                 | 275(25)                | 2399(356)    | 1014(123)    | -35(58)      | -43(46)      | -70(130)     | 0.156     | 0.182     | 0.227     | 0.330   |
| V                 | 0.92(38)Å <sup>2</sup> |              |              |              |              |              |           |           |           |         |
| X-ray data        |                        |              |              |              |              |              |           |           |           |         |
| Cs(1)             | 192(3)                 | 1107(19)     | 1069(19)     | 0            | 0            | 0            | 0.150     | 0.154     | 0.163     | 0.270   |
| Cs(2)             | 277(5)                 | 2859(34)     | 650(17)      | 0            | 0            | 0            | 0.127     | 0.181     | 0.247     | 0.331   |
| V                 | 165(9)                 | 889(50)      | 457(37)      | 0            | 0            | 0            | 0.107     | 0.138     | 0.139     | 0.223   |
| O                 | 214(42)                | 666(191)     | 1104(203)    | 0            | 0            | 0            | 0.119     | 0.159     | 0.166     | 0.259   |
| F                 | 344(17)                | 1859(115)    | 1702(87)     | -25(37)      | -35(34)      | -1261(86)    | 0.108     | 0.202     | 0.265     | 0.350   |
| O <sub>w</sub>    | 224(40)                | 913(205)     | 687(176)     | 0            | 0            | 0            | 0.131     | 0.140     | 0.163     | 0.251   |

<sup>a</sup>  $\beta_{ij}$  values are given in Å<sup>2</sup> × 10<sup>5</sup>. Estimated standard deviations are given within parentheses. The rms components ( $R_i$ ) of thermal displacements along the ellipsoid axes and the rms radial ( $R$ ) thermal displacements are included.

1.919(4)(Å) and to one water molecule with a distance of 2.268(8) Å. The vanadium atom is situated 0.29 Å out of the plane formed by the four fluorines, toward the oxygen atom.

The observed V–O distance is realistic for a V–O double bond. The corresponding two V–O double bonds observed in the vanadate (IV)  $\text{CsVOF}_3 \cdot \frac{1}{2}\text{H}_2\text{O}$  (12) are 1.583 and 1.595 Å. The  $\text{V}^{5+}$ –O distances found in  $\text{CsVOF}_4$  (13) and  $\text{VOF}_3$  (14) are 1.529 and 1.57 Å, respectively, and in  $\text{K}_2\text{VO}_2\text{F}_3$  (15) the two V–O bonds within the same octahedron are both 1.636 Å.

The observed V–F distances are terminal, and they are in fair agreement with the average terminal V–F distances found in  $\text{K}_2\text{VO}_2\text{F}_3$ ,  $\text{K}_2\text{VOF}_4$  (16), and  $\text{CsVOF}_4 \cdot \frac{1}{2}\text{H}_2\text{O}$  of 1.89, 1.90 and 1.89 Å, respectively, but longer than those in  $\text{CsVOF}_4$  and  $\text{VOF}_3$  (1.79 and 1.70 Å).

The hydrogens in the  $\text{H}_2\text{O}$  molecule are symmetry related by a mirror plane orthogonal to  $c$ . The  $\text{O}_w$ –H distance is 0.987(7) Å,

or 1.005 Å if corrected for thermal vibrations. The H–H distance is 1.568(12) Å, or 1.621 Å if corrected for thermal motions based on an independent-motion model. The H– $\text{O}_w$ –H angle is 105.1(9)°.

The hydrogen bonds ( $\text{O}_w$ –H  $\cdots$  F) result in an orientation of the two hydrogens in a water molecule toward the fluorines on one of the sides of the mirror plane perpendicular to  $b$ . The hydrogens may be supposed to be equally distributed on both sides of the mirror plane.

The water molecules as ligands to the vanadium makes it possible to describe the structure as formed by chains of octahedra running infinitely in the  $c$  direction. The  $[\text{VOF}_4(\text{H}_2\text{O})]^{2-}$  ions are connected to each other by two hydrogen bonds. The acceptor atoms are the fluorines (see Fig. 3). The hydrogen-bond distance ( $\text{O}_w \cdots \text{F}$ ) is 2.901(3) Å, the donor distance ( $\text{O}_w$ –H) 0.987(7) Å, and the acceptor distance ( $\text{H} \cdots \text{F}$ ) 1.919(7) Å. The  $\text{O}_w$ –H  $\cdots$  F angle is 172.6(7)°. These values are in fair

TABLE III  
 INTERATOMIC DISTANCES (Å) AND BOND ANGLES IN Cs<sub>2</sub>[VOF<sub>4</sub>(H<sub>2</sub>O)]<sup>a</sup>

(a) [VOF<sub>4</sub>(H<sub>2</sub>O)]<sup>2-</sup> ion

|                      | Metal-ligand distances |          | Distances between ligands |           |
|----------------------|------------------------|----------|---------------------------|-----------|
|                      | Neutron                | X-ray    |                           |           |
| V-O                  | 1.62                   | 1.602(8) |                           |           |
| -F 4(x)              | 1.92                   | 1.919(4) |                           |           |
| -O <sub>w</sub>      | 2.29                   | 2.268(8) |                           |           |
|                      | Angles (°)             |          |                           |           |
|                      | Neutron                | X-ray    | Neutron                   | X-ray     |
| O-V-F (4x)           | 99                     | 98.6(1)  | 2.692(4)                  | 2.678(7)  |
| -O <sub>w</sub>      | 180                    | 180.0    | 3.910(4)                  | 3.870(11) |
| F-V-F (2x)           | 89                     | 88.7(2)  | 2.694(5)                  | 2.683(7)  |
| -F (2x)              | 88                     | 88.7(2)  | 2.679(5)                  | 2.683(7)  |
| -F (2x)              | 163                    | 162.8(2) | 3.800(4)                  | 3.794(7)  |
| -O <sub>w</sub> (4x) | 81                     | 81.4(1)  | 2.760(4)                  | 2.742(7)  |

(b) H<sub>2</sub>O molecule

|                           | Neutron               | Corrected |
|---------------------------|-----------------------|-----------|
| O <sub>w</sub> -H (2x)    | 0.987(7)              | 1.005     |
| H-H                       | 1.568(12)             | 1.621     |
| H-O <sub>w</sub> -H angle | 105.1(9) <sup>o</sup> | (107.5°)  |

## (c) Cs(1) polyhedron

|                 | Neutron  | X-Ray    |
|-----------------|----------|----------|
| Cs(1)-F (4x)    | 3.144(4) | 3.146(3) |
| -H (2x)         | 3.183(7) | —        |
| -O (2x)         | 3.249(1) | 3.251(1) |
| -F (4x)         | 3.304(4) | 3.306(3) |
| -O (2x)         | 3.511(1) | 3.512(1) |
| -O <sub>w</sub> | 3.515(4) | 3.529(8) |

## (d) Cs(2) polyhedron

|                      | Neutron  | X-ray    |
|----------------------|----------|----------|
| Cs(2)-H (2x)         | 2.958(9) | —        |
| -F (4x)              | 3.034(3) | 3.036(3) |
| -O <sub>w</sub> (2x) | 3.273(1) | 3.276(1) |
| -O                   | 3.277(4) | 3.296(1) |
| -F (4x)              | 3.376(4) | 3.372(3) |
| -H (2x)              | 3.718(9) | —        |

## (e) Remaining important distances and angles

|                          | Neutron               | X-ray    |
|--------------------------|-----------------------|----------|
| F-H                      | 1.919(7)              | —        |
| -H                       | 2.404(8)              | —        |
| -O <sub>w</sub> (2x)     | 2.901(3)              | 2.915(5) |
| F-H-O <sub>w</sub> angle | 172.6(7) <sup>o</sup> |          |

<sup>a</sup> Estimated standard deviations in last decimal place are given within parentheses. For the neutron data the errors in the vanadium-ligand distances are estimated to be ±0.05 Å.



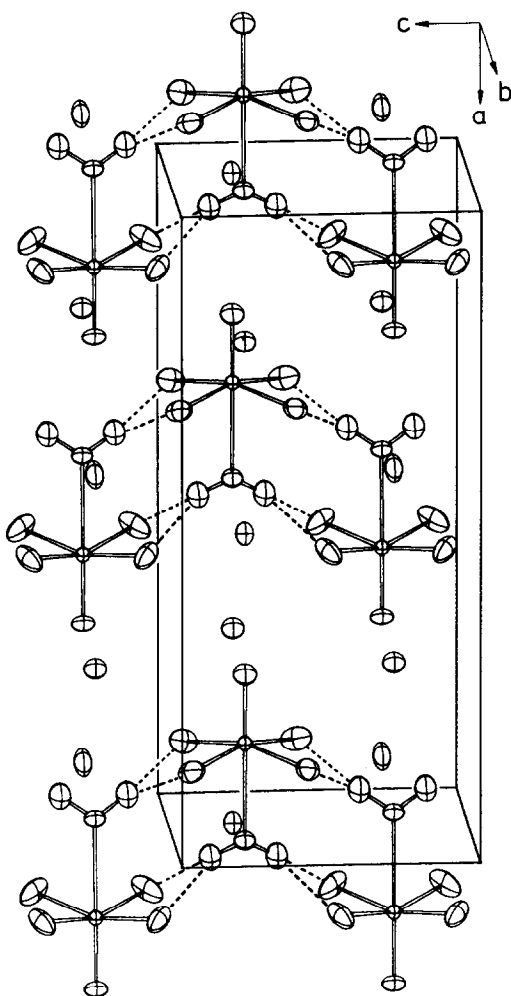

FIG. 3. The structure of  $\text{Cs}_2[\text{VOF}_4(\text{H}_2\text{O})]$ . The  $[\text{VOF}_4(\text{H}_2\text{O})]^{2-}$  ions are connected by hydrogen bonds, and form chains of octahedra running infinitely in the  $c$  direction.

agreement with corresponding data for  $\text{O}-\text{H}\cdots\text{F}$  hydrogen bonds recently reviewed by Simonov and Bukvetsky (17). These authors list  $\text{O}_w\cdots\text{F}$  hydrogen-bond lengths varying in the range 2.56–2.86 Å and  $\text{H}\cdots\text{F}$  distances between 1.61 and 2.39 Å (average 1.83 Å) for a total of 46 hydrogen bonds. The  $\text{O}_w-\text{H}\cdots\text{F}$  angles are in the region of 123–180°, with 80% of the reported angles with 165–180°. The two  $\text{O}_w\cdots\text{F}$  hydrogen bonds found in  $\text{CsVOF}_3\cdot\frac{1}{2}\text{H}_2\text{O}$  are 2.560 and 2.814 Å (12).

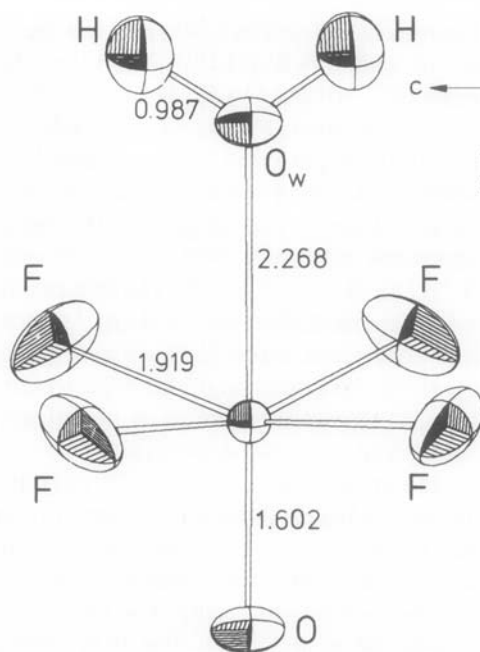

FIG. 4. The  $[\text{VOF}_4(\text{H}_2\text{O})]^{2-}$  ion. The vanadium-ligand distances (Å) are determined from the X-ray data.

The coordinations of the two crystallographic cesium atoms differ from each other. Within the coordination sphere of Cs(1) there are eight fluorines, four oxygens, and one water molecule; for Cs(2) there are eight fluorines, one oxygen, and two water molecules. The  $\text{H}_2\text{O}$  molecule within the coordination polyhedron of Cs(1) is orientated with the hydrogens toward the cesium atom, while the two  $\text{H}_2\text{O}$  molecules of Cs(2) have an orientation nearly perpendicular to the  $\text{O}_w-\text{Cs}(2)$  vector.

Atovmyan and Aliev (18) reported the crystal structure of  $\text{Cs}_2[\text{VOCl}_4(\text{H}_2\text{O})]$  based on three-dimensional X-ray diffraction data (conventional  $R$  value 0.08). The structure is orthorhombic;  $a = 10.96$ ,  $b = 9.27$ , and  $c = 10.09$  Å;  $Z = 4$ ; space group  $\text{Cmcm}$  (No. 63). The general features of the deformed octahedral complex  $[\text{VOCl}(\text{H}_2\text{O})]^{2-}$  are in good agreement with my results; e.g., the  $\text{V}-\text{O}$  bond length is 1.63(4) Å, the distance to the oppositely situated  $\text{OH}_2$  ligand, 2.31(6) Å.

Piovesana and Selbin (19) reported the ir data of the  $[\text{VOF}_4(\text{H}_2\text{O})]^{2-}$  ion in the compound  $(\text{NH}_4)_2[\text{VOF}_4(\text{H}_2\text{O})]$ . They found the following absorption bands (in  $\text{cm}^{-1}$ ): 980 (very strong), 955 (medium), 735 (medium), 512 (very strong, broad), and 325 (medium, sharp), and suggested the band assignments  $\nu_1(\text{V}=\text{O})$ , 980, 955;  $\nu(\text{V}-\text{F})$ , 735, 512; and  $\nu(\text{V}-\text{O})$ , 325. The two strong bands found in the 900- to 1000- $\text{cm}^{-1}$  region might arise from *trans*  $\text{H}_2\text{O}-\text{V}=\text{O}$  grouping, since two bands might be expected for  $\nu(\text{V}=\text{O})$  whenever there is a chemically bound group *trans* the oxo-oxygen.

In the ir spectrum of  $\text{Cs}_2[\text{VOF}_4(\text{H}_2\text{O})]$ , visualized in Fig. 1, there are two absorption bands in the 900- to 1000- $\text{cm}^{-1}$  region: 980 and 950  $\text{cm}^{-1}$ , probably arising from the *trans*  $\text{H}_2\text{O}-\text{V}=\text{O}$  grouping. The two bands are assigned to  $\nu(\text{V}=\text{O})$ . The very strong and broad band at 540  $\text{cm}^{-1}$  is assigned to  $\nu(\text{V}-\text{F})$  vibration.

Further ir data, collected on a single-beam instrument, show all these bands, including those originating from the  $\text{H}_2\text{O}$  group, but also a weak, sharp absorption band at 730  $\text{cm}^{-1}$  assigned to  $\nu(\text{V}-\text{F})$  vibration. The ir data of  $\text{Cs}_2[\text{VOF}_4(\text{H}_2\text{O})]$  are therefore in excellent agreement with those reported for  $(\text{NH}_4)_2[\text{VOF}_4(\text{H}_2\text{O})]$ .

### Acknowledgments

I am thankful to Dr. Karl-Axel Wilhelmi for helpful discussions and to Professor Arne Magnéli for his kind interest. I wish also to thank Dr. Roland Tellgren and

Mr. Stig Lundholm for valuable assistance and discussions, and Dr. Sven Westman for revising the English text. This investigation has been supported by the Swedish Natural Science Research Council.

### References

1. A. CARPY AND K. WALTERSSON, *C.R. Acad. Sci. Paris* **274**, 405 (1972).
2. K. WALTERSSON, K. A. WILHELMI, A. CARPY, AND J. GALY, *Bull. Soc. Fr. Mineral. Cristallogr.* **97**, 13 (1974).
3. G. PAUSEVANG, *Z. Anorg. Allg. Chem.* **381**, 189 (1971).
4. A. CARPY, Dissertation, Bordeaux (1973).
5. H. H. WILLARD AND O. B. WINTER, *Ind. Eng. Chem. Anal. Ed.* **5**, 7 (1933).
6. P. G. HAMBLING, *Acta Crystallogr.* **6**, 98 (1953).
7. R. TELLGREN, P. S. RAMANUJAM, AND R. LIMINGA, *Ferroelectrics* **6**, 191 (1974).
8. "International Tables for X-Ray Crystallography," Vol. III, p. 197, Kynoch Press, Birmingham (1962).
9. G. E. BACON, *Acta Crystallogr. Sect. A* **28**, 357 (1972).
10. W. C. HAMILTON, *Acta Crystallogr.* **18**, 502 (1965).
11. K. WALTERSSON, *J. Solid State Chem.*, in press.
12. G. W. BUSHNELL AND K. C. MOSS, *Canad. J. Chem.* **50**, 3700 (1972).
13. A. J. EDWARDS AND P. TAYLOR, *Chem. Commun.*, 1474 (1970).
14. R. R. RYAN, S. H. MASTIN, AND M. J. REISFELD, *Acta Crystallogr. Sect. B* **27**, 1270 (1971).
15. K. WALTERSSON AND B. KARLSSON, *Cryst. Struct. Commun.* **7**, 459 (1978).
16. V. I. SIMONOV AND B. V. BUKVETSKY, *Acta Crystallogr. Sect. B* **34**, 355 (1978).
17. L. O. ATOVMYAN AND Z. G. ALIEV, *Zh. Strukt. Khim.* **11**, 782 (1970).
18. O. PIOVESANA AND J. SELBIN, *J. Inorg. Nucl. Chem.* **31**, 433 (1969).
19. K. WALTERSSON, *Cryst. Struct. Commun.* **7**, 507 (1978).