

The Defect Structure of Anion Excess CaF₂

C. R. A. CATLOW*

*Department of Chemistry, University College London, 20 Gordon Street,
London WC1H 0AJ, England*

AND A. V. CHADWICK

*University Chemical Laboratory, University of Kent, Canterbury, Kent
CT2 7NH, England*

AND J. CORISH†

Chemistry Department, University College, Dublin 4, Ireland

Received February 22, 1982; and in final form November 1, 1982

Neutron scattering and computer simulation techniques have been used to investigate the defect cluster structure of CaF₂ doped with 5% La³⁺. The results strongly support the formation of small discrete clusters rather than the superstructures that have been suggested in recent studies of anion excess fluorites. The type of cluster that emerges as dominant comprises an interstitial-dopant dimer (of the 2:2:2 type) which has captured an additional F⁻ interstitial. The formation of such clusters is supported by recent ITC studies.

Introduction

Anion excess fluorite compounds are possibly the best available systems for structural studies of the properties of solid solutions. The structure of the host lattice is particularly simple: high concentrations of dopants are possible; and the introduction of dopants has marked effects on the structural properties of the phase. Trivalent dopants (Y³⁺ and the rare earth cations) are dissolved in the fluorite host to induce an excess anion concentration; and the basic structural properties of the phase may be described in the language of classical defect theory as the creation of interstitials to pro-

vide charge compensation for the effective charge of the dopant ions.

The above description is accurate for highly dilute solutions of trivalent ions in the alkaline earth fluorides. Spectroscopic studies (1-3) have shown that the structural properties of these phases may be described in terms of simple clusters involving F⁻ ions located at the cubic interstitial site of the fluorite lattice, with the interstitials in nearest neighbor and next nearest neighbor sites with respect to the dopant. The resulting dopant-interstitial pairs are illustrated in Fig. 1a and b.

Diffraction data (4-9) on crystals of higher dopant concentrations (5-40 mole%) reveal, however, the breakdown of these simple models, since interstitials are no longer detected at the cubic interstitial

* To whom correspondence should be addressed.

† Present address: Chemistry Department, Trinity College, Dublin 2, Ireland.

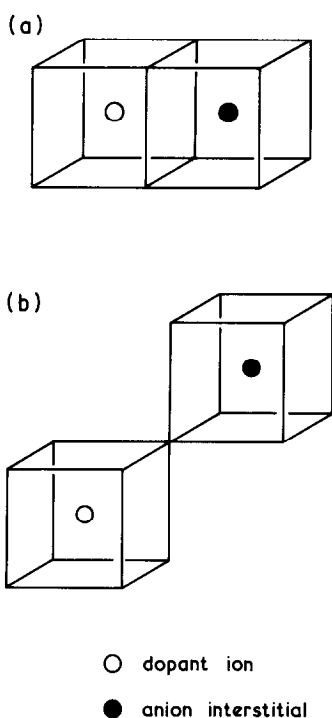

FIG. 1. Simple dopant-interstitial complexes in doped CaF_2 : (a) nearest neighbor (tetragonal) cluster; (b) next nearest neighbor (trigonal) cluster.

sites. Interpretations of the structural properties of these phases have nevertheless used cluster models; the aggregates proposed are considerably more complex than those shown in Fig. 1a and b and involve interstitial dimers and trimers known as the 2:2:2 and 4:3:2 clusters, illustrated in Fig. 2a and b. Aggregates of this type rationalize the principle features of the neutron diffraction data of Cheetham *et al.* (4) on Y doped CaF_2 and of Willis (5) on the structurally analogous nonstoichiometric phase UO_{2+x} . Least squares refinements of the Bragg diffraction data of both sets of workers showed that interstitial ions were present in positions displaced from the cubic interstitial sites along $\langle 110 \rangle$ and $\langle 111 \rangle$ axes. The relative proportion of the two types of interstitial (and of the vacancies which are detected at the anion sites) is

compatible with the presence of the 2:2:2 cluster at ~ 5 mole% and the 4:3:2 cluster at ~ 10 –15 mole% dopant concentration.

An explanation of the formation of these low symmetry complexes was advanced by Catlow (10) on the basis of computer simulation studies. Thus for the (2:2:2) cluster it was proposed that the inward movement along the $\langle 110 \rangle$ axis of interstitials due to their interaction with the trivalent cations was assisted by displacement of neighboring lattice ions along the $\langle 111 \rangle$ direction. Similar explanations were proposed for the stabilization of the 4:3:2 cluster.

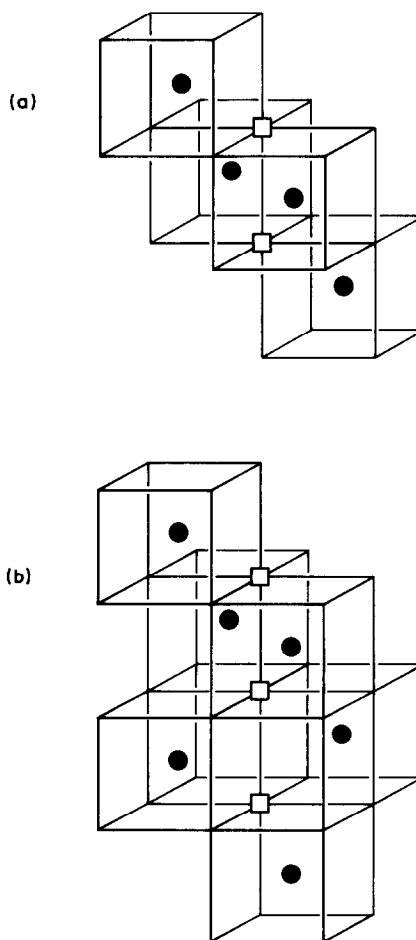

FIG. 2. Interstitial aggregates in doped CaF_2 : (a) 2:2:2 cluster; (b) 4:3:2 cluster.

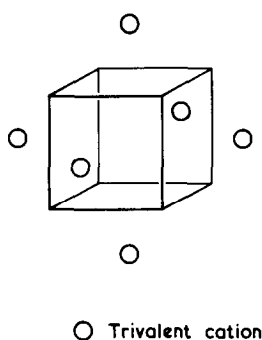

FIG. 3. Proposed distribution of dopant ions in a cubo-octahedral aggregate.

Interpretation of the structural properties of these phases in terms of such cluster models has been challenged in a series of papers of Greiss and coworkers (6–9). Their approach to the structural properties of these phases is guided by “domain” theories of nonstoichiometry (11), rather than discrete cluster models as discussed above. An important structural feature in their description of these phases is the cube octahedron shown in Fig. 3. The experimental basis for their observations are X-ray diffraction studies of the doped crystals, often at very high dopant concentrations (>30 mole%) and on materials which had been annealed for long periods.

There is, of course, no necessary incompatibility between cluster and domain models of nonstoichiometry, when the former are considered as appropriate to the relatively low concentration range and the latter to the regions of very high dopant levels. Discrete cluster models must indeed be inappropriate for the more heavily doped systems where typically more than one in three of the cation sites may be occupied by impurities. The question remains, however, as to whether small discrete cluster models are an appropriate basis for describing the structural properties of doped fluorite phases for other than very lightly doped solutions. The question is highlighted by a recent neutron diffraction

study of Bendall *et al.* (12, 13) on 10% Pr^{3+} doped SrCl_2 , which suggested that for this system the models of the type proposed by Greiss and coworkers might be appropriate. In addition, Bendall (12) carried out a reanalysis of the single crystal neutron diffraction data of Cheetham *et al.* (4) which he tentatively suggests could be compatible with Greiss’s superstructure models.

In view of these doubts as to the status of discrete cluster models of the (2:2:2) type, we have undertaken a detailed neutron diffraction study of one particular system: CaF_2 doped with 5 mole% La. This was chosen first because the relatively low dopant concentration should allow interpretation of the defect structure in terms of discrete models (if these exist) and second because calculations (14, 26) suggested that (2:2:2) and (4:3:2) clusters were more likely to be stable relative to other aggregates, with large dopants such as La^{3+} . Our interpretation of the neutron scattering data in terms of cluster models is assisted by computer simulation studies. We find convincing evidence for the formation of small discrete clusters in this solid solution, although the detailed cluster we propose differs from the (2:2:2) model. Our work has, we believe, general consequences as it supports the description of the structure of nonstoichiometric phases in terms of defect clusters for intermediate as well as lightly doped defect solutions.

Sample Preparation

Single crystals (6 mm diameter \times 40 mm length) were grown from LaF_3 – CaF_2 mixtures in graphite crucibles (Ultra Carbon UF4S grade) by a modified Stockbarger technique (Figueroa *et al.* (15)). The CaF_2 starting material was single crystal pieces grown from pure powder prepared by reacting CaCO_3 (BDH Analar grade) with an excess of aqueous HF (BDH Analar grade). The LaF_3 dopant was 4N purity powder

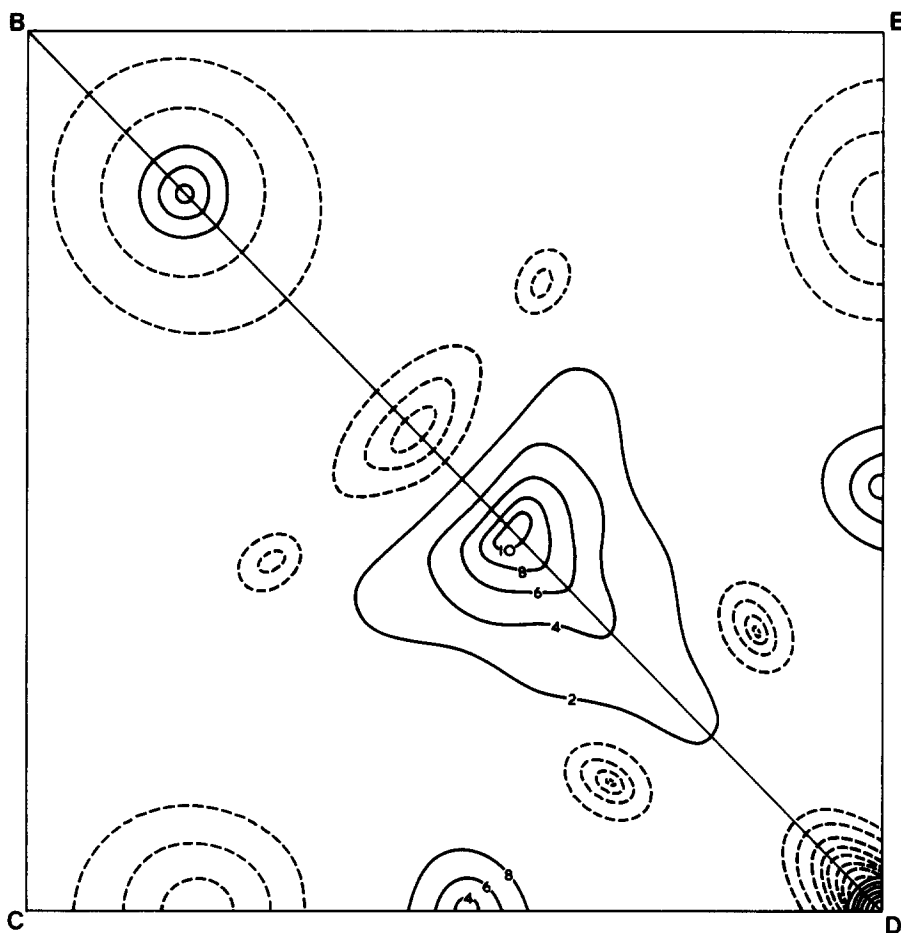

FIG. 4a. $\langle 100 \rangle$ Fourier difference section.

(Rare Earth Products Limited). Immediately prior to growth the mixtures were kept molten for several hours to ensure a complete mixing of the components. A growth rate of 18 mm/hr was employed. The crystals were not annealed after growth and were simply cooled to room temperature at a rate of 4 K/min. The crystals had poorly defined cleavage planes which were approximately perpendicular to the growth axis. Several slices, 3 to 4 mm thick, were cleaved from each crystal. One slice was retained for the neutron experiments and the La^{3+} concentration in the immediately adjacent slices was determined by neutron activation analysis (Universities

Research Reactor, Risley). The concentration of La^{3+} was confirmed as 5 mole%.

Spherical samples, approximately 2 mm diameter, were ground from the slices using a grinder similar to that described by Bond (16). The variation in diameter of the spheres was less than $\pm 1\%$. X-ray measurements were taken to determine the crystal axes and the mosaic spread of the spheres.

Neutron Scattering Experiments

Our single crystal neutron diffraction study was performed using the 4 circle diffractometer, D9, at the Institut Laue-

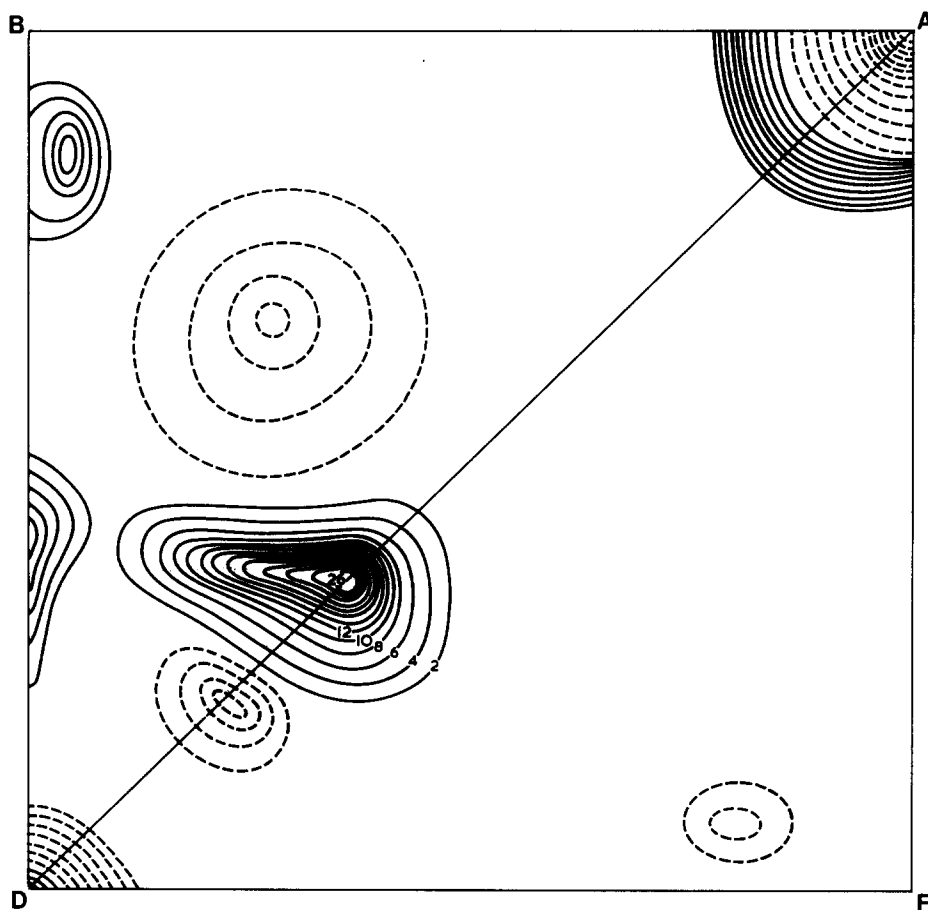

FIG. 4b. $\langle 110 \rangle$ Fourier difference section.

Langevin Grenoble. The data were collected at 80°K to minimize thermal effects. We used a short wavelength of 0.525 \AA enabling us to collect a large number of reflections. Neutron count rates were determined at 30 points across the center of each peak so that the peak and adjacent background could be accurately determined. A total of 1376 reflections were measured (corresponding to a total of 172 independent peaks). The average count (after subtraction of background), for each independent reflection is available on request.¹

¹ See NAPS document No. 04090 for 3 pages of supplementary material. Order from ASIS/NAPS, Microfiche Publications, P.O. Box 3513, Grand Central Station, New York, NY 10163. Remit in advance \$4.00

Comparison of the symmetry related reflections revealed no systematic differences, and demonstrated that the statistics of the data were good. The experimental data were analyzed using the X-ray program (17). Absorption effects are calculated to be low ($\mu R_s \sim 0.02$). Effects due to this effect can therefore be adequately allowed for by variations in the scale factor applied to the

for microfiche copy or for photocopy, \$7.75 up to 20 pages plus \$.30 for each additional page. All orders must be prepaid. Institutions and organizations may order by purchase order. However, there is a billing and handling charge for this service of \$15. Foreign orders add \$4.50 for postage and handling, for the first 20 pages, and \$1.00 for additional 10 pages of material. Remit \$1.50 for postage of any microfiche orders.

measured intensities. Extinction is not expected to be significant at the wavelength used in this experiment; and there was no evidence for systematic reduction in the intensities of the strongest peaks. However, to avoid the possibility of errors from this source, the most intense reflections (220) and (400) were omitted from all least squares refinements.

An effective method of elucidating defect structure from Bragg scattering data is to plot the difference between the observed Fourier synthesis and that calculated for the perfect lattice. In the present case, however, a problem arises in calculating structure factors for the perfect lattice as the scattering lengths for Ca and F are not known with high accuracy at the low wavelengths used in the present experiment. We therefore performed a least squares refinement based on the perfect lattice (i.e., with interstitials omitted) in which the anion occupation numbers and the temperature factors were allowed to vary. Variation of the occupation number will accommodate any change in the relative scattering length of the two lattices. Thus using the reported scattering lengths for Ca^{2+} and F of 0.49 and 0.56, respectively, the data refined (with a weighted R factor of 2.6%) to give an anion occupation number of 0.954, with temperature factors for the calcium and fluorine ions of 0.372 and 0.526 \AA^2 , respectively. Difference Fourier maps using this refined structure were then used to display the interstitial structure.

The main features of the resulting difference maps are brought out by the $\langle 100 \rangle$ and $\langle 110 \rangle$ sections shown in Figs. 4a and b. The relation of these sections to the fluorite unit cell is illustrated in Fig. (5). Two prominences are immediately noted: the first, apparent in the $\langle 100 \rangle$ section, is displaced

along the $\langle 110 \rangle$ axis from the cubic interstitial site. We note, however, from the $\langle 110 \rangle$ section that this feature extends appreciably out of the $\langle 100 \rangle$ plane. The second major feature is displaced along the $\langle 111 \rangle$ axis from the cubic interstitial site and is seen in the $\langle 110 \rangle$ section. A third smaller peak is also noted; this is situated along the $\langle 110 \rangle$ axis, but displaced much farther from the cubic interstitial sites than the larger peak referred to above.

The two main features noted in the difference section may clearly be identified with $\langle 110 \rangle$ and $\langle 111 \rangle$ interstitials discussed in the Introduction. However, we find marked differences between the difference maps obtained from the present data and those for Pr/SrCl_2 and for Y/CaF_2 (12, 13). The $\langle 111 \rangle$ interstitial is a much more pronounced feature in La doped CaF_2 , a result which suggests that the cluster structure in this sample may differ from that suggested by Cheetham *et al.* (4) for the Y^{3+} doped phase and by Bendall *et al.* (12, 13) for Pr/SrCl_2 .

We attempted to explore this possibility using least squares fitting techniques. However, we found that the standard deviations

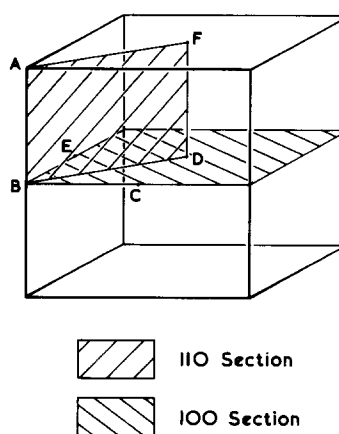

FIG. 5. Relation of $\langle 100 \rangle$ and $\langle 110 \rangle$ sections, through interstitial site, used for Fourier differences map in Fig. 4. Letters A–F indicate points marked in Fig. 4. D is body-centre interstitial site.

² The scattering length used was slightly modified to take account of the fact that 5% of the Ca sites are occupied by La ions.

in the interstitial occupation numbers were too high to permit reliable conclusions to be drawn. The best refinement gave a weighted R factor of 2.1% for occupation numbers close to those appropriate for the 2:2:2 model; changes in the occupation numbers produced, however, only very small alterations in the R factor. Least squares refinements appear therefore to be an unreliable method of obtaining information on the structures of interstitial excess defective systems. The problem arises from the use in the least squares technique of temperature factors which assume a Gaussian distribution of scattering density around a given site; this adequately represents temperature effects but does not describe satisfactorily the static distribution of scattering density in heavily defective systems. Use of anisotropic temperature factors did not significantly affect this problem which is especially pronounced in the present study due to the use of a short wavelength. For this reason we believe that Fourier maps, of the type discussed above, provide a more satisfactory method of analyzing the experimental data.

The neutron scattering data thus provide strong evidence for the existence of $\langle 111 \rangle$ and $\langle 110 \rangle$ interstitials in La/CaF₂. The results do, however, differ significantly from those obtained in previous studies. The $\langle 111 \rangle$ interstitials are a particularly marked feature of the data, and have

greater prominence than was apparent in studies of other doped fluoride crystals. It does not seem possible from the neutron data alone to deduce the details of the cluster structure in the sample. To assist the interpretation of the data we therefore explore a number of cluster models with the aid of computer simulation techniques which are discussed in the next section.

Calculations

The techniques employed are those used in our previous study of the stabilisation of the 2:2:2 cluster (10, 18). The methods are based on a generalised Mott-Littleton procedure (19) employing shell model (20) lattice potentials for the explicit simulation of a region of the crystal surrounding the defect.³ The techniques have been extensively applied to the study of energetics of defect formation and aggregation in alkali halides (21, 22) as well as the alkaline earth fluorides (14, 23-25). These studies have demonstrated the quantitative reliability of the calculations which are reviewed in references (20) and (27).

We have recently undertaken a major survey of defect energetics in doped alkaline earth fluorides (14). The primary aim of this work is to determine the effects of the radius of the dopant and the lattice parameter of the host on the energetics of clustering. As remarked in the Introduction, the study has shown that formation of dopant dimers and trimers is expected to be especially favored in La/CaF₂. The present calculations, which are concerned exclusively with the latter system, follow exactly the same procedures as in our more general study. In particular, we use the same potentials for the host lattice interactions (taken from Catlow *et al.* (24)) and for the dopant-host interactions (obtained using electron

TABLE I
VALUES OF THE ADDITIONAL PARAMETERS
USED WITH THE CaF₂ POTENTIAL OF
CATLOW *et al.* (24) TO REPRESENT THE
CaF₂:La³⁺ SYSTEM^a

Interaction	$\text{\AA}/\text{eV}$	$\rho/\text{\AA}$
La ³⁺ - Ca ²⁺	25549.6	0.2152
La ³⁺ - F ⁻	2537.5	0.2980

^a Potentials are of the form $\phi_{ij}(r) = A_{ij} \exp(-r_{ij}^{\rho_{ij}})$

³ A general program (HADES) is available for calculations using these techniques (20, 21).

TABLE IIa
CALCULATED DEFECT ENERGIES FOR THE
CaF₂:La³⁺ SYSTEM

Defect	Energy (eV)
Anion interstitial	-2.062
Substitutional La ³⁺	-19.244
n.n. La ³⁺ -F ⁻ interstitial pair	-22.105
n.n.n. La ³⁺ -F ⁻ interstitial pair	-21.690
2:2:2 complex	-44.629
2:2:2 complex with additional F ⁻ ion (Fig. 6)	-47.974

TABLE IIb
ASSOCIATION ENERGIES FOR CLUSTERS

Term	Energy (eV)
Binding energy of n.n. pair with respect of isolated La ³⁺ and F ⁻ interstitial	0.799
Binding energy of n.n.n. pair with respect to isolated La ³⁺ and F ⁻ interstitial	0.384
Binding energy of 2:2:2 complex with respect to two n.n. pairs	0.419
Binding energy of additional interstitial to 2:2:2 cluster to give 3/2 aggregate	1.283

gas methods (14, 30, 29)). The La. . .F and La. . .Ca potential parameters are reported in Table I.

The calculated defect energies necessary for our present purposes are given in Table IIa. From these values a variety of association energies for the clusters may be obtained; these are reported and explained in Table IIb. The first point to note is the greater stability for the n.n. dopant-interstitial complex (Fig. 1a) compared with the corresponding n.n.n. cluster. Our comprehensive survey (14) of the doped alkaline earth fluorides has shown that this is a general effect: n.n. complexes are preferred for systems with a high ratio of dopant radius to lattice parameter of which La/CaF₂ is an

extreme example. The point is relevant when we note that 2:2:2 and 4:3:2 clusters are essentially nearest neighbor dimers and trimers, respectively. Next we note that the 2:2:2 cluster is only weakly bound with respect to these two simple n.n. dopant-interstitial clusters. The binding energy for the 4:3:2 cluster is similar.

Moreover, on examining the structure predicted by the calculations for the 2:2:2 cluster, we find a marked difference from that normally associated with this defect. The calculations showed that the <111> relaxations are absent, and the two interstitials are close to the centers of their cubic interstitial sites. The term 2:2:2 has indeed ceased to be appropriate; the cluster is essentially a straightforward dopant-interstitial dimer. The results of the neutron scattering studies on this system could clearly not be interpreted in terms of this species. Is there any way in which such clusters may be stabilized? One possibility suggested by a number of workers (31-34) is that the neutral clusters may trap additional interstitials; capture by the 2:2:2

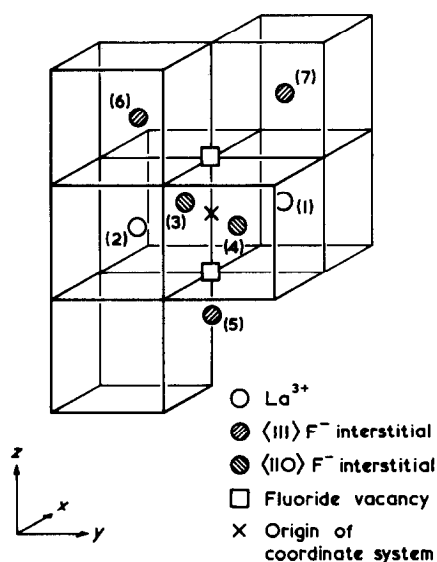

FIG. 6. 2|3 cluster. Coordinate system used in Table III is indicated.

TABLE III
FINAL CONFIGURATIONS OF THE 2|3 CLUSTER^a

Ion number	2:2:2 cluster with additional F ⁻ ion (see Fig. 6)		
	x	y	z
1	0.49018	0.49018	0.02432
2	-0.49019	-0.49019	0.02429
3	0.36445	-0.36438	0.15581
4	-0.36445	0.36438	-0.15581
5	0.00019	0.00019	-0.62980
6	-0.36913	-0.36913	0.87330
7	0.36911	0.36911	0.87347

^a That is, the complex formed by the 2:2:2 cluster and an additional $\langle 111 \rangle$ interstitial fluoride ion. The ion numbers are as designated in Fig. 6. All coordinates are in units of the F \cdots F nearest neighbor lattice spacing.

cluster of a further interstitial would result in the formation of the cluster shown in Fig. 6—a model that has indeed already been proposed on the basis of experimental (32, 35) and computer simulation studies (36). We adopt a new terminology at this stage, labeling this cluster a “2|3” cluster—indicating three interstitial and two dopant ions. (The same convention would label the 2:2:2 structures and simple *n.n.* and *n.n.n.* pairs as 2|2 and 1|1 clusters, respectively.) We will find these terms useful later.

The results of the calculations on the “2|3” structure given in Table IIb demonstrate considerable enhanced stability for this defect compared with the neutral dimer (2|2 cluster); the latter has an exceptionally high affinity for additional interstitials which are bound by 1.3 eV. The calculated structure is given in Table III, which refers to Fig. 6. We note that the $\langle 111 \rangle$ interstitials are now restored. Moreover, we find appreciable displacement of the $\langle 110 \rangle$ interstitials out of the $\langle 100 \rangle$ plane, a feature which we recall was also noted in the difference Fourier maps deduced from the neutron scattering studies.

Discussion

The unambiguous demonstration by the neutron scattering experiments of the existence of $\langle 111 \rangle$ interstitials in 5 mole% La/CaF₂ rules out an interpretation of the cluster structure of this material in terms of the cube-octahedra models (Fig. 3) of the type developed by Greiss. The latter explain the formation of $\langle 110 \rangle$ F⁻ ions, but $\langle 111 \rangle$ species are not present in these clusters. Since the calculations show that conventional (2:2:2) clusters do not form in La/CaF₂, and since the intensity of the $\langle 111 \rangle$ peak in the difference Fourier maps would not seem to be compatible with the formation of 4:3:2 clusters, the “2|3” cluster discussed at the end of the last section seems to be the most likely dominant cluster structure. Further support for the formation of this species is obtained by comparing the position of the $\langle 111 \rangle$ peak in the difference Fourier map with that calculated for the 2|3 structure, where excellent agreement is found. Significant discrepancies are found between the positions of calculated and observed $\langle 110 \rangle$ interstitials; but as we have argued elsewhere (18), there are probably significant covalent interactions between these interstitials resulting in an anomalously short F⁻-F⁻ distance in the cluster.

The formation of “2|3” clusters, however, presents an immediate problem. Since this cluster contains an excess of interstitials over dopant ions, other clusters must be present with a deficiency of interstitials in order to retain the overall dopant/interstitial ratio of unity. There are two plausible models for the interstitial deficient species. The first is the simple unassociated, dopant ion, the formation of which would imply a favorable free energy for the reaction

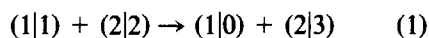

(using the cluster terminology introduced in

the previous section). In addition it is assumed that there exists a sufficient number of simple clusters and isolated dopant ions at these concentrations. The second type of species is the 2|1 (or "2:1:2") cluster formed by loss of an interstitial from the (2|2) (or "2:2:2") cluster, the formation of which implies the disproportionation reaction

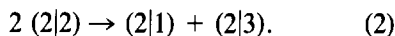

To test the viability of this and the preceding reaction, calculations were performed on the (2|1) structure using the techniques and potentials discussed in the previous section; we obtained an energy of -41.501 eV. Using this result we calculate a favorable energy of 0.22 eV for the disproportionation reaction discussed above. The energy obtained for reaction (1) is also favorable by 0.48 eV. It is probable that both unassociated La^{3+} and 2|1 clusters are present in this system.

The formation of interstitial excess clusters has received support from both relaxation measurements and ionic conductivity studies. Thus Fontanella *et al.* (32) in an investigation of the dielectric loss spectrum of Er^{3+} doped CaF_2 find a peak which

could possibly be assigned to the 2|3 cluster. Moreover, the same workers, in an ITC study of the sample employed in the neutron scattering investigations reported in this paper, found that the peak assigned to this cluster is now the dominant feature of the spectrum (Fontanella and Matthews, private communication). The activation energy measured by Fontanella and Matthews was ~ 1 eV. A satisfactory assignment of this peak to the 2|3 cluster clearly requires that a mechanism may be proposed giving an activation energy of this magnitude. We propose the dipolar reorientation mechanism which is illustrated and explained in Fig. 7. Accurate calculations on the activation energy for this mechanism are difficult owing to its complexity. However, a plausible saddle point was identified giving a calculated activation energy of 1.2 eV. This result provides, we believe, further support for the existence of 2|3 clusters in this crystal. Finally we note that conductivity measurements of Jacobs and Ong (31) on Y/CaF_2 could only be adequately rationalized by models involving the release and capture of interstitials by neutral complexes. It would be of interest to determine whether the same type of models are required for the La/CaF_2 system.

The combination of neutron scattering data and the calculated cluster energies obtained from the computer simulation studies together with the experimental results discussed above makes, we believe, a good case for the formation of the (2|3) cluster (and by inference the 2|1 or 1|0 species). To what extent could this behavior be a feature of the nature of the dopant and of the concentration used in the present study? As remarked, a separate study (14), shows that dopant-interstitial binding energies decrease with increasing dopant ion radius, and that smaller clusters might therefore be most likely to form in samples containing the large La^{3+} ion. In addition we note that

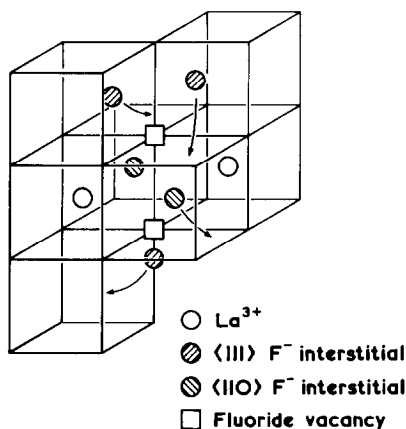

FIG. 7. Proposed reorientation mechanism for (2|3) complex. Arrows indicate direction of motion of interstitials during reorientation.

the dopant concentrations used in the present work are relatively low and that on going to higher concentrations more extensive aggregation may lead to superclusters of the type suggested by Greiss *et al.* (for which Bendall *et al.* (12, 13) believe they have found evidence in Pr/SrCl_2 and possibly Y/CaF_2). Experimental studies designed to investigate concentration and dopant-radius effects would clearly be of interest. A further important parameter is, we believe, the length of the annealing time used in preparing the samples. In Greiss's work this was long—a feature which should promote the formation of large superclusters. Therefore, systematic studies of this factor would also be of value.

Conclusions

The work summarized in this paper clearly provides strong support for the validity of simple cluster models containing two or three dopant ions in regions of intermediate dopant concentration. Supercluster models may become more appropriate for heavily doped samples, but the range of validity of simple discrete cluster models extends well beyond the region of high dilution to which they would be confined by "domain" approaches to the structures of nonstoichiometric compounds. The particular cluster that appears to emerge as most important in 5 mole% La/CaF_2 is the interstitial excess "2|3" dopant dimer shown in Fig. 6. The result is gratifying in view of the proposals by several workers recently of the importance of this type of cluster. The suggestion of this cluster as the dominant species in La/CaF_2 provides a good illustration of the power of concerted application of neutron scattering methods and computer simulation techniques.

Acknowledgments

We are grateful to Dr. B. E. F. Fender, Dr. J. Fon-

tanella, and Dr. P. W. M. Jacobs for several useful discussions, and to the Computer Centre, University College Dublin and Amdahl (Ireland) Ltd. We would also like to thank Dr. H. J. Milledge for use of X-ray facilities and Mr. J. Allibon for assistance with the D9 experiment at ILL.

Note added in proof. The terminology introduced in this paper for dopant interstitial clusters has been expanded to differentiate between nearest neighbour and next nearest neighbour associates as described fully in reference 14.

References

1. J. M. BAKER, E. R. DAVIES, AND J. P. HURRELL, *Proc. R. Soc. A* **308**, 403 (1968).
2. J. M. BAKER, in "Crystals with the Fluorite Structure" (W. Hayes, Ed.), Oxford Univ. Press (Clarendon), London/New York (1974).
3. D. S. MOORE AND J. C. WRIGHT, *J. Chem. Phys.* **74**, 1626 (1981).
4. A. K. CHEETHAM, B. E. F. FENDER, AND M. J. COOPER, *J. Phys. C* **4**, 3107 (1971).
5. B. T. M. WILLIS, *Proc. Brit. Ceram. Soc.* **1**, 9 (1964).
6. O. GREISS, *Z. Anorg. Allg. Chem.* **430**, 175 (1977).
7. O. GREISS AND T. PETZEL, *Z. Anorg. Allg. Chem.* **403**, 1 (1974).
8. O. GREISS AND D. J. M. BEVAN, *J. Solid State Chem.* **24**, 113 (1978).
9. W. GETTMAN AND O. GREISS, *J. Solid State Chem.* **26**, 255 (1978).
10. C. R. A. CATLOW, *J. Phys. C* **6**, L64 (1973).
11. For a discussion of the domain approach to the structure of nonstoichiometric phases, see J. S. ANDERSON in "Problems in Non-Stoichiometry" (A. Rabenau, Ed.), North-Holland, Amsterdam (1970).
12. P. J. BENDALL, D. PHIL. Thesis, Univ. of Oxford (1980).
13. P. J. BENDALL, C. R. A. CATLOW, AND B. E. F. FENDER, *J. Phys. C* **14**, C4377 (1981).
14. J. CORISH, C. R. A. CATLOW, P. W. M. JACOBS, AND S. M. ONG, *Phys. Rev. B* **25**, 6425 (1982).
15. D. R. FIGUEROA, A. V. CHADWICK, AND J. H. STRANGE, *J. Phys. C* **11**, 55 (1978).
16. W. L. BOND, in "Crystal Technology," p. 257, Wiley, New York (1976).
17. "The X-ray System"—Version of June 1972, Technical Report—TR192 of the Computer Centre, Univ. of Maryland (June 1972).
18. C. R. A. CATLOW, *J. Phys. C* **9**, 1845 (1976).
19. N. F. MOTT AND M. J. LITTLETON, *Trans. Farad. Soc.* **34**, 485 (1978).

20. C. R. A. CATLOW AND W. C. MACKRODT, Computer simulation of solids, in "Lecture Notes in Physics," vol. 166, Springer-Verlag, Berlin (1982).
21. C. R. A. CATLOW, R. JAMES, W. C. MACKRODT, AND R. F. STEWART, *Phys. Rev. B*, in press.
22. C. R. A. CATLOW, J. CORISH, K. M. DILLER, M. J. NORGETT, AND P. W. M. JACOBS, *J. Phys. C*, **11**, 197 (1979).
23. C. R. A. CATLOW, J. CORISH, P. W. M. JACOBS, AND J. M. QUIGLEY, *Phil. Mag.* **A44**, 13 (1981).
24. C. R. A. CATLOW AND M. J. NORGETT, *J. Phys. C*, **6**, 1325 (1973).
25. C. R. A. CATLOW, M. J. NORGETT, AND T. A. ROSS, *J. Phys. C*, **10**, 1627 (1977).
26. J. CORISH, C. R. A. CATLOW, AND P. W. M. JACOBS, to be published.
27. C. R. A. CATLOW, *J. Phys. (Paris)* **C6**, 53 (1980).
28. B. G. DICK AND A. W. OVERHAUSER, *Phys. Rev.* **112**, 90 (1958).
29. P. T. WEDEPOHL, *Proc. Phys. Soc.* **92**, 79 (1967).
30. R. G. GORDON AND Y. S. KIM, *J. Chem. Phys.* **56**, 3122 (1972).
31. P. W. M. JACOBS AND S. H. ONG, *J. Phys. Chem. Solids* **41**, 431 (1980).
32. J. FONTANELLA, D. J. TREACY, AND C. ANDEEN, *J. Chem. Phys.* **72**, 2235 (1980).
33. P. P. YANEY, D. H. SCHAEFFER, AND J. M. WOLF, *Phys. Rev. B* **11**, 2460 (1975).
34. D. R. TALLANT, D. S. MOORE, AND J. C. WRIGHT, *J. Chem. Phys.* **67**, 2897 (1977).
35. C. ANDEEN, D. LINK, AND J. J. FONTANELLA, *Phys. Rev. B* **16**, 3762 (1977).
36. C. G. ANDEEN, J. J. FONTANELLA, M. C. WINTERSGILL, P. J. WELCHER, R. J. J. KIMBLE, AND G. E. MATTHEWS, *J. Phys. C*, **14**, C3557 (1981).