

## An EPR Study of Rhodium Oxihydroxide

E. MORAN MIGUELEZ AND M. A. ALARIO FRANCO

*Departamento de Química Inorgánica, Facultad de Ciencias Químicas, Universidad Complutense. Madrid 3, and Instituto "Elhuyar" CSIC, Madrid 6, Spain*

AND J. SORIA

*Instituto de Catálisis, CSIC, Madrid 6, Spain*

Received June 22, 1982

Rhodium oxihydroxide has been synthesized by means of hydrothermal synthesis at 1500 bars and 600°C in acidic media. Powder X-ray diffraction shows small variations in cell parameters which appear to be related to the oxidizing power of the reaction media. On the basis of EPR work such variations can be attributed to the presence of small amounts of either Rh(II) or Rh(IV). This last species had not been fully characterized before by EPR in oxide-like materials. The paramagnetic species seem to be noninteracting and randomly distributed in the Rh(III) sites. These results can be understood on the basis of two different kinds of nonstoichiometry for rhodium oxihydroxide: either proton or hydroxyl ion defects.

### Introduction

Rhodium appears to be the only transition metal of the second series forming an oxihydroxide which adopts the orthorhombic InOOH-type structure. In the first series, however, this type of structure is much more frequent, being adopted by the oxihydroxides of Sc, V, Cr, Fe, and Ni(III); manganese also adopts a related structure which is somewhat deformed due to a Jahn-Teller effect, the symmetry becoming monoclinic. These factors are undoubtedly related to the higher stability of the trivalent oxidation state in the first transition series. On the other hand, dioxides of the transition elements are more frequent in the second and third series than in the first, since in these series, the higher oxidation

states (IV and over) are normally more stable. In this particular instance, rhodium and indium are exceptional;  $\text{In}^{3+}$ , being a  $d^{10}$  ion, is a very stable one and the stability of  $\text{Rh}^{3+}$  is also related to its electronic configuration since, in this low-spin case, the  $d^6$  electrons are distributed as  $t_{2g}^6 e_g^0$  in the octahedral field.

All these oxihydroxides are quite dense phases and require high pressures (of the order of 1000 bars) to be crystallized. Explicitly, rhodium oxihydroxide was obtained for the first time by Chenavas *et al.* (1) in a Belt apparatus at very high pressures (80 kbar, 600°C, NaOH 6 M). On the other hand, rhodium dioxide, a black powder which adopts the rutile-type structure and has metallic conductivity, was synthesized independently by Shannon (2) and

Muller and Roy (3) at high oxygen pressures.

We present in this paper a simpler procedure for preparing both compounds by hydrothermal synthesis. We also found that rhodium oxihydroxide, in contrast to all other known orthorhombic InOOH-type oxihydroxides, can be slightly nonstoichiometric, and we studied, mainly by EPR, the rhodium oxidation states responsible for the compositional variations.

### Experimental

Polycrystalline samples of RhOOH and  $\text{RhO}_2$  were obtained by hydrothermal synthesis in gold tubes, sealed at both ends, and treated within a steel autoclave heated externally in an experimental setup fully described elsewhere (4). The pressures, of the order of 1 to 2 kbar, were measured during the experiment by means of an Ashcroft manometer, while the temperatures were controlled by a Cr-CrAl thermocouple located outside the autoclave. Previously, an approximate calibration of

the gradient between the internal and external temperatures was performed with the autoclave filled with alumina and placed in the same experimental setup.

We found that the best conditions to obtain RhOOH are a suspension of  $\text{Rh}_2\text{O}_3$  in a solution of hydrochloric or nitric acids 0.1 M, at 2000 bars and 600°C for 48 hr; lower pressure or less time results in a less well crystallized product. Rhodium oxihydroxide can be considered a high-pressure-high-temperature phase, since at temperatures lower than 500°C and pressures below 300 bars only a red rhodium(III) solution is produced. When hydrochloric acid is employed at concentrations over 1 M, besides the oxyhydroxide, a well-crystallized rhodium(III) chloride, in the form of hexagonal red platelets, is obtained.

With regards to  $\text{RhO}_2$ , the best procedure appears to be a suspension of  $\text{Rh}_2\text{O}_3$  in 7 M  $\text{HNO}_3$  or 2.7 M  $\text{HClO}_3$ , at about the same pressure, temperature, and heating time mentioned above for RhOOH. For lower concentrations of oxidizing acid a mixture of both  $\text{RhO}_2$  and RhOOH was obtained.

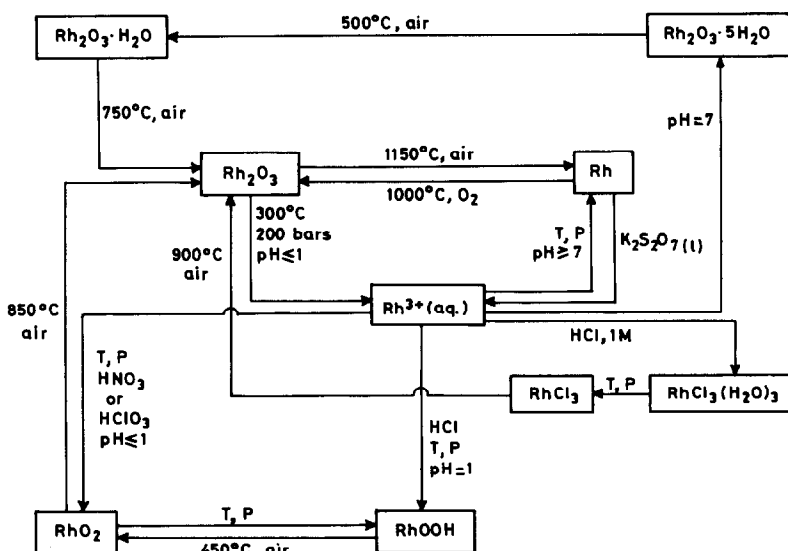

FIG. 1. Synthetic routes followed in this work.  $T = 600^\circ\text{C}$ ,  $P = 1500$  bars.

Our attempts to prepare  $\text{RhO}_2$  at atmospheric pressure by the thermal decomposition in air of rhodium oxide gels, as suggested by Bayer and Wiedemann (5), failed. It is worth mentioning that rhodium dioxide can be easily reduced to the orthorhombic oxihydroxide by hydrothermal synthesis (6).

In basic media,  $\text{Rh}_2\text{O}_3$  is mostly reduced to the metal. Pure water does not produce reaction with the anhydrous sesquioxide, but a mixture of the metal and  $\text{RhOOH}$  is obtained when the hydrated gel-like form  $\text{Rh}_2\text{O}_3 \cdot 5\text{H}_2\text{O}$  is used. Figure 1 shows a resumé of the different synthetic routes followed in this work.

X-Ray diffraction was done on a Philips 1310 unit, using  $\text{CuK}\alpha$  radiation and high-purity silicon as internal standard. Thermal analysis was performed on a Mettler T 1 thermoanalyzer and/or a thermogravimetric apparatus based on a Cahn balance. EPR experiments were made on a JEOL JES-PE-3X spectrometer; a solid solution of  $\text{Mn(II)}$  in magnesium oxide was used as a standard.

## Results

### (i) X-Ray Diffraction

The interplanar spacings obtained by means of X-ray diffraction for the  $\text{RhO}_2$  samples were in good agreement with those reported in the bibliography, the corresponding cell parameters are:

$$a = b = 4.487(3) \text{ \AA}, c = 3.091(3) \text{ \AA}, \\ V = 62.25(3) \text{ \AA}^3 \text{ (present work),}$$

$$a = b = 4.489(1) \text{ \AA}, c = 3.090(1) \text{ \AA}, \\ V = 62.27(2) \text{ \AA}^3 \text{ (Ref. (3)).}$$

In the case of  $\text{RhOOH}$ , although the interplanar spacings obtained can all be indexed on the basis of the  $\text{InOOH}$ -type

TABLE I  
UNIT CELL PARAMETERS OF DIFFERENT SAMPLES  
OF  $\text{RhOOH}$  (a)

<i>a</i> (\AA)	<i>b</i> (\AA)	<i>c</i> (\AA)	<i>V</i> (\AA <sup>3</sup> )	Reaction medium
4.924	4.291	3.082	65.12	NaOH, 80 kbar (Ref. (1))
4.929(1)	4.291(1)	3.083(1)	65.21(2)	HCl aq., 1.5 kbar
4.932(1)	4.308(3)	3.045(1)	64.71(3)	$\text{HNO}_3$ aq., 1.5 kbar
4.911(3)	4.297(2)	3.045(1)	64.24(3)	$\text{HClO}_3$ aq., 1.5 kbar

<sup>a</sup> Orthorhombic, space group  $P2_1nm$ .

structure, space group  $P2_1nm$ , some dimensional variations, which appear to be related to the oxidizing power of the reaction medium, can be observed. Typical examples are given in Table I.

### (ii) Thermal Analysis

As reported in detail elsewhere (6), the thermal decomposition in air of rhodium oxihydroxide can be expressed by the following equations:

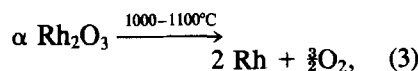
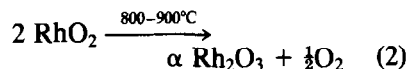
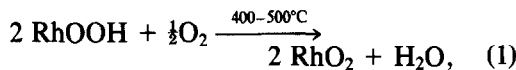

all these processes being endothermic.

It should be noted that the experimental weight loss observed in the thermal decomposition of different samples of  $\text{RhOOH}$  appears also to be dependent on the oxidizing power of the acidic medium employed in their synthesis. In this way, the samples obtained in an oxidizing acid medium did lose the amount of weight expected in Eq. (1); however, those samples that were obtained in a nonoxidizing medium had a weight loss somewhat smaller,  $\sim 0.5\%$  less than expected.

(iii) *Electron Paramagnetic Resonance*

The EPR spectra of the different samples can also be classified in two groups according to the oxidizing power of the reacting acidic medium: reddish, HCl-prepared samples usually present two signals, an orthorhombic signal with  $g_1 = 2.260$ ,  $g_2 = 2.150$ ,  $g_3 = 2.006$  (signal A, Fig. 2), and an axial one with  $g_{\perp} = 2.07$ ,  $g_{\parallel} = 2.39$  (signal B, Fig. 2);  $g_{\parallel}$  is very broad and not well resolved. The spectra of these reddish samples are similar at 300 and 77K, although at low temperature the contribution of signal A seems to be smaller, probably because of line broadening. In some cases only one of the signals is present (Figs. 2b and c).

The second group of samples, prepared in an oxidizing medium, had a darker color and showed, at 77K, a signal that is characteristic of a paramagnetic species under an

orthorhombic crystal field, with  $g_1 = 2.25$ ,  $g_2 = 2.08$ ,  $g_3 = 1.94$  (signal C, Fig. 3). In general this signal is not well resolved at room temperature because of line broadening as shown in Fig. 3a.

In order to obtain further information on these signals, a reddish sample, showing only signals A and B, was treated in air at increasingly higher temperatures. At 200°C, a smaller contribution of signal B to the spectrum was observed. Heating for half an hour at 300°C produced a spectrum with the three signals; longer treatments at 300°C or higher temperatures resulted in gradual elimination of the signals; at the same time increasing difficulty in tuning the microwave cavity was experienced. This last effect was also observed when studying samples of rhodium dioxide.

None of the three observed signals was affected by the external oxygen pressure during the EPR measurements. On the other hand, the three signals showed a large anisotropy in the  $g$  values. This can be at-

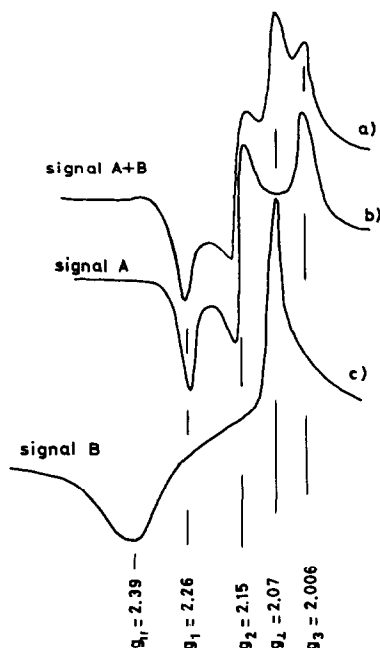

FIG. 2. EPR spectra at room temperature of RhOOH samples obtained in reducing media. (i) 1500 bars, 600°C, HCl. (ii) 2000 bars, 600°C, HCl. (iii) 80,000 bars, 600°C, NaOH.

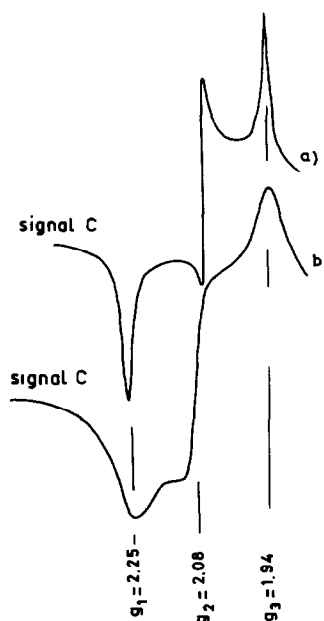

FIG. 3. EPR spectra taken at 300 and 77K of a RhOOH sample obtained in HNO<sub>3</sub>.

tributed to the presence of a transition metal cation, a rhodium cation in the present case. As no influence of the surrounding atmosphere was observed on the signals, it can be inferred that, on the main, the paramagnetic species are not on the sample surface.

### Discussion

The experimental results shown above indicate that rhodium oxihydroxide can be slightly nonstoichiometric. The cation normally present in this solid is diamagnetic: Rh(III),  $d^6$  in this low-spin case,  $t_{2g}^6 e_g^0$  in the oxygen octahedral field. However, if nonstoichiometry is indeed present, paramagnetic Rh(II) and Rh(IV) are the most likely cations to be responsible for it. This makes EPR a suitable technique to use in this case.

Signals A and B, observed in the HCl-prepared samples, have  $g$  values higher than  $g_e$ , as is usually found for ions with their  $d$ -manifold more than half-filled. This type of signal has been assigned to  $Rh^{2+}$  in other studies of rhodium-containing samples (7, 8), although in some cases it was assigned to  $Rh^0$  (9). A signal similar to A has been found by Kazanskii *et al.* (7) for rhodium supported on silica gel and was assigned to Rh(II) ions in a square-pyramidal or distorted tetrahedral coordination.

Calculations carried out by Townsend (8) for the case of a Rh(II) ion in a compressed octahedral crystal field, with the unpaired electron in the  $d_{xy}$  level, gives the values  $g_{\parallel} = 2.375$  and  $g_{\perp} = 2.04$ , which are very similar to those observed for signal B. The signal obtained by Wilkins *et al.* (9) for rhodium in AgCl is somewhat different, although it has a similar symmetry and has been assigned to  $Rh^0$  in an elongated octahedral environment. Although the EPR parameters do not constitute enough evidence to discard the presence of  $Rh^0$ , the synthesis conditions (see experimental part

above) are against such an interpretation. On the basis of these considerations signals A and B are both assigned to  $Rh^{2+}$  ions placed in different environments. Signal B was more influenced than signals A or C by both the thermal treatment and the temperature at which the measurements were performed, either room temperature or 77K.

On the other hand, signal B was the only one present for samples prepared in a basic medium at very high pressures (NaOH, 80 kbar). On the other hand, signal A was the only one present for samples prepared hydrothermally in acidic nonoxidizing media. As the reduction of  $Rh^{3+}$  to  $Rh^{2+}$  has to be electrically compensated with the elimination of either  $OH^-$  groups or  $O^{2-}$  ions, signals A and B may well be related to these two possibilities.

Samples prepared in a nitric or chloric acid solution show only the orthorhombic C signal, with one of its  $g$  values smaller than  $g_e$ . Metal ions with a  $d^5$  configuration and orthorhombic symmetry have usually two  $g$  values higher than 2 and the other one below 2. The detection of  $Rh^{4+}$  ions (with a  $4d^5$  configuration) by EPR has previously been claimed in several other systems: Raizman *et al.* (10) and Kazanskii *et al.* (7) assigned the signals with  $g_1 = 2.092$ ,  $g_2 = 2.031$ ,  $g_3 = 1.963$ , obtained after oxygen adsorption at room temperature on a Rh/SiO<sub>2</sub> sample evacuated at 200–500°C, to  $Rh^{4+}$  ions in a tetragonally distorted octahedral crystal field. On the other hand, Yao and Shelef (11), studying a sample of Rh/Al<sub>2</sub>O<sub>3</sub> heated at 500°C in air, interpreted a symmetrical band with a  $g$  value of 2.14 as  $Rh^{4+}$ , and considered the signal of Kazanskii as a  $RhO_2^+$  adduct. In our case, however, since the conditions employed for preparing the samples showing signal C were very oxidizing, the presence of  $Rh^{4+}$  will appear as the most likely possibility. This seems to be confirmed by the fact that, heating in air at 300°C a sample of RhOOH containing  $Rh^{2+}$ , signal C (attributed to

Rh<sup>4+</sup>) is obtained. Thermal analysis showed that the oxidation process  $\text{RhOOH} \rightarrow \text{RhO}_2$  starts at about 300°C. As in the metallic-type dioxide the Rh<sup>4+</sup> ions are magnetically coupled, and this material cannot be studied by EPR. This process can be schematized as follows:



(Rh<sup>2+</sup>)

signals A, B

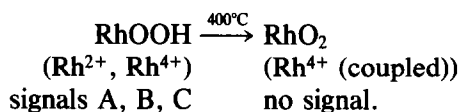

It can be concluded that signals A and B are due to Rh(II) species placed in two different environments. These signals are obtained in those samples that, having been prepared in a reducing medium, have a unit cell volume which is somewhat larger than that of the samples prepared in an oxidizing one (Table I). In those last samples a different signal, signal C, which can be attributed to Rh(IV) ions, was observed.

Although no quantitative relation has been established, it is worth stressing that the unit cell volumes of the samples having a certain amount of Rh(IV) were smaller than those corresponding to samples having some Rh(II). This is what one would expect on the basis of an ionic model.

Compositional variations in "RhOOH" can then be accounted for by the following formulae:

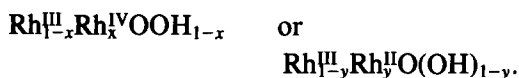

Nevertheless, the range of compositional variations is quite small. In this way it is to

be recalled that the differences between observed and calculated weight losses in thermogravimetric experiments were almost undetectable in the Rh(IV)-containing samples. In the case of the Rh(II)-containing samples the maximum  $y$  value observed was of the order of  $y \approx 0.05$ .

### Acknowledgments

We are grateful to Professors J. C. Joubert and J. Chenavas (Laboratoire de Cristallographie, CNRS, Grenoble, France) for supplying some high-pressure samples, for the experimental facilities put at our disposal, and for helpful discussions.

### References

1. J. CHENAVAS, J. C. JOUBERT, J. J. CAPPONI, AND M. MAREZIO, *J. Solid State Chem.* **6**, 1 (1973).
2. R. D. SHANNON, *Solid Stat Commun.* **6**, 139 (1968).
3. O. MULLER AND R. ROY, *J. Less-Common Met.* **16**, 129 (1968).
4. E. MORAN-MIGUELEZ, Thesis, Universidad Complutense, Madrid (1981).
5. G. BAYER AND H. G. WIEDEMANN, *Thermochim. Acta* **15**, 213 (1976).
6. E. MORAN-MIGUELEZ AND M. A. ALARIO-FRANCO, "Proceedings, Second European Symposium on Thermal Analysis, Aberdeen, Scotland" (D. Dollimore, Ed.), pp. 413-416, Heyden & Son, London (1981).
7. V. B. KAZANSKII, V. E., SHUBIN, AND V. A. SHVETS, *Kinet. Catal.* **19**, 1026 (1978).
8. M. G. TOWNSEND, *J. Chem. Phys.* **41**, 3149 (1964).
9. J. WILKINS, D. P. GRAAG, AND J. H. HELLE, *Phys. Lett.* **19**, 178 (1965).
10. A. RAIZMAN, J. SUSS, AND S. SZAPIRO, *Phys. Lett. A* **32**, 30 (1970).
11. H. C. YAO AND M. SHELEF, Seventh International Congress on Catalysis, Preprint A 21.