

Structure of a Sodium-Neodymium Aluminate with Mixed β -Alumina and Magnetoplumbite Structure

A. KAHN AND J. THERY

U.A. 302-CNRS, Laboratoire de Chimie Appliquée de l'Etat Solide, ENSCP 11 rue Pierre et Marie Curie, 75231 Paris Cedex 05, France

Received October 14, 1985

The structure of a mixed sodium-neodymium aluminate has been investigated on a single crystal. It reveals hexagonal symmetry (SG $P6m2$, $Z = 1$) and the unit cell ($a = 5.57$, $c = 22.25$ Å) is described as an alternate stacking of half β -alumina unit cell and half magnetoplumbite unit cell. This leads to an ordering between the layers of large ions Na^+ and Nd^{3+} in the c direction. © 1986 Academic Press, Inc.

Introduction

β -alumina-type alkaline aluminates and magnetoplumbite (MP) type rare earth aluminates belong to a large family of compounds, the structure of which is made of spinel-like blocks separated by mirror planes containing the big cations, alkaline or lanthanide.

The space group is $P6_3/mmc$. The main difference between the two structural types lies in the mirror planes which are, respectively, loose-packed and close-packed in β -alumina and in magnetoplumbite phases.

Properties of many compounds in this structural family have been extensively studied in our laboratory, particularly for Na β -alumina $\text{NaAl}_{11}\text{O}_{17}$ (1), a superionic conductor, and for LNA, (La,Nd)Mg $\text{Al}_{11}\text{O}_{19}$, a high-power laser material (2, 3).

The relationship between β -alumina-like and MP-like compounds has led us to synthesize mixed aluminates involving alkaline and rare earth ions. In the systems $\text{Na}_2\text{O}-$

$\text{Ln}_2\text{O}_3-\text{MgO}-\text{Al}_2\text{O}_3$ and $\text{Na}_2\text{O}-\text{Ln}_2\text{O}_3-\text{Al}_2\text{O}_3$, sodium/lanthanum (SLA) or sodium/neodymium (SNA) aluminates have been prepared, either as powder samples or as single crystals, by high-temperature processes which have been previously reported (4, 5) (and not by ionic exchange on β -alumina).

Preliminary X-ray investigations have shown not only the main features of Na^+ or Ln^{3+} aluminates but also a loss of symmetry, leading to a different space group for the new structure. This relationship has been also found in the physical properties of these mixed aluminates which exhibit an ionic conductivity, like β -alumina, and optical properties similar to those of Ln^{3+} aluminates.

In this paper, we report the results of the crystallographic study of SNA, a mixed sodium-neodymium aluminate, in order to check the consistency of this structure with the physical behavior of the material. Both Na^+ and Nd^{3+} are concerned in these properties.

Preliminary Considerations

The X-ray powder pattern of this new phase reveals a hexagonal unit cell with nearly the same lattice constants as the parent structures of magnetoplumbite and β -alumina. However, strong $00l$ lines with $l = 2n + 1$ are observed which are forbidden in the $P6_3/mmc$ space group.

This was confirmed by a comprehensive study on a single crystal for which the starting composition was $11.5 \text{ Al}_2\text{O}_3 - 0.65 \text{ Na}_2\text{O} - 0.5 \text{ Nd}_2\text{O}_3$. Laue, rotation and Weissenberg diffraction patterns exhibit a lower symmetry which corresponds to the absence of c glide plane. In the more symmetric group $P6_3/mmc$, this particular symmetry element made equivalent the two mirror planes of the structure where the big cations Na^+ or Nd^{3+} were localized (Fig. 1a).

As no superstructure was detected in the planes perpendicular to the c axis, we have chosen the $P6m2$ space group, which corresponds to the $P6_3/mmc$ group, with no inversion center and allows a dissociated occupation of the successive mirror planes. The crystal structure has then be refined in the $P6m2$ group which assumes an order between Nd^{3+} and Na^+ ions along the c direction with no change in the unit-cell parameters (Fig. 1b).

High-resolution electron microscopy has been performed in the pertinent crystallo-

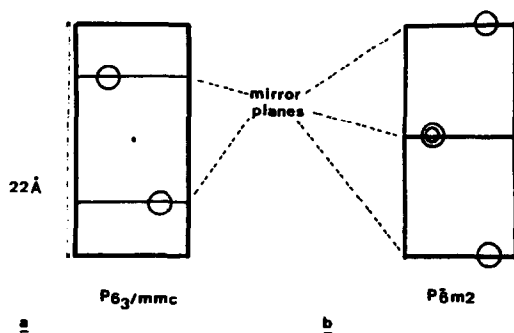

FIG. 1. (a) Schematic structure of magnetoplumbite or β -alumina ($P6_3/mmc$). (b) Schematic structure of SNA ($P6m2$).

TABLE I
EXPERIMENTAL DATA

Crystal size	Platelet $0.3 \times 0.4 \times 0.1$ mm
Crystal symmetry	$P6m2$
Lattice constants	
at 297 K	$a = b = 5.570 \text{ \AA}$ $Z = 1$ $c = 22.257$ $\gamma = 120^\circ$
Density	3.5 Mg/m^3
Data collection	CAD-3 Nonius diffractometer Graphite monochromator 604 reflections measured $\theta/2\theta$ scan $\theta_{\max} = 40^\circ$ $h \geq k \geq 0$ $l \geq 0$ $\lambda \text{MoK}\alpha = 0.7107$
Data corrections	Absorption corrections based on the crystal morphology linear absorption coefficient = 27 cm^{-1}
Refinement factor	$R = 0.049$ $R_w = 0.053$ with 464 reflections
Atomic scattering factors:	Cromer and Waber's table in "International Tables for X-ray Crystallography," Vol. IV, 1974

graphic directions of a crystalline sample. It gives evidence of successive layers of equivalent atoms separated by 22 \AA , as expected in our model (Fig. 2). No simulation has been attempted but the interdistance between the atomic layers does not depend on defocus or contrast.

Structure Refinement

A platelet-shaped single crystal was mounted on a CAD-3 Nonius diffractometer on which data collection was performed; 604 independent reflections were measured in the conditions given in Table I and corrected for Lorentz polarization and absorption effects.

The starting parameters for refining the structure of SNA in $P6m2$ were those of MP lanthanum hexaaluminate (2) transposed in the new space group, with a splitting due to the lack of inversion center (for instance, 12 Al (12k) give 6 Al_I + 6 Al_{Ibis} (6n), see Table II).

A few refinement steps gave out the positional parameters of the spinel-block atoms and the localization of Nd^{3+} in the mirror plane at $z = 0.5$. This ion has three oxygen

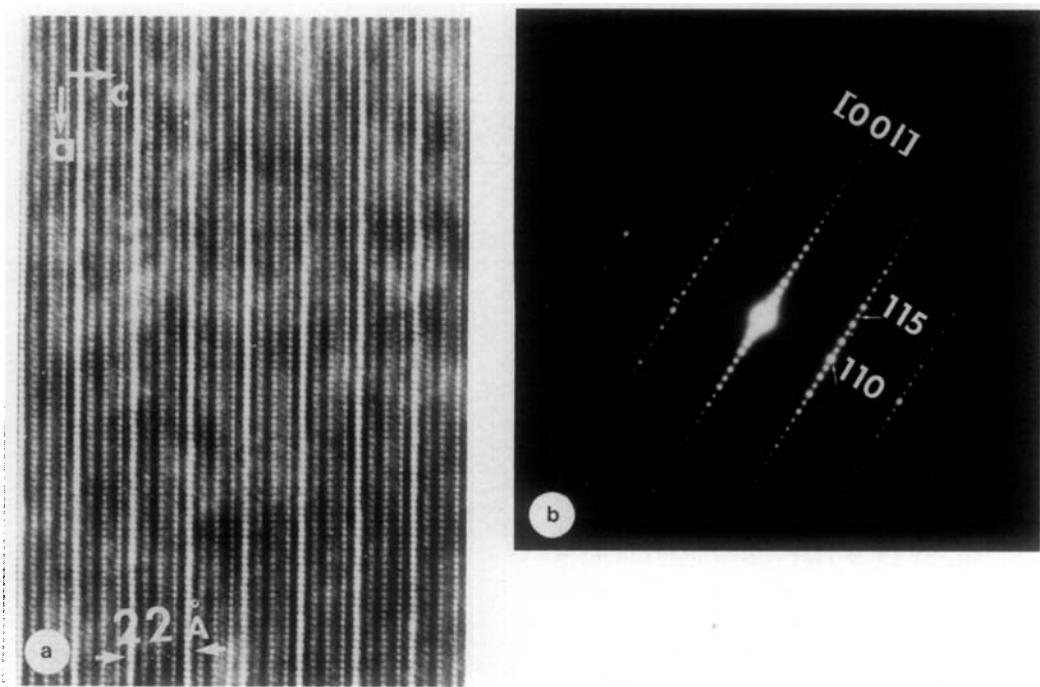

FIG. 2. Electron microscope image of SNA. (Performed on a JEOL 200 CX microscope equipped with an ultra-high-resolution polar piece and goniometer stage.) (a) Visualization of atomic planes, with incident beam normal to the (100) plane, and showing periodic distances of 22 Å between similar atomic layers. (b) Corresponding electron diffraction pattern showing $[hhl]$ rows with all values of l .

neighbors. With the four Al atoms at the "corners" of this unit cell section, they constitute a close-packed layer (Fig. 3). (Notice that the real position of $\text{Al}_{3\text{bis}}$ is slightly shifted out of the mirror plane.)

A Fourier difference map provided the location of Na^+ ions in the other mirror plane ($z = 0$) (Fig. 4). This ion is spread over two different sites with partial occupancy and high values of thermal factors. One oxygen ion only is found in this plane; therefore this layer is loosely packed with high disorder. The final R value is 0.049 with isotropic thermal factors and corresponds to the set of atomic parameters of Table II. Utilization of anisotropic thermal factors would decrease the large uncertainties on Na and O_5 positions, but requires more variable parameters (and more data). Both descriptions account for the same dynamic disorder (cf. Table II).

The difference between the two mirror

planes induces some differences in the spinel blocks too; for instance, the coordination of Al_3 is tetrahedral near the $z = 0$ mirror plane, whereas $\text{Al}_{3\text{bis}}$ is in an octahedral environment (Fig. 5). Table III gives the main interatomic distances around the cations.

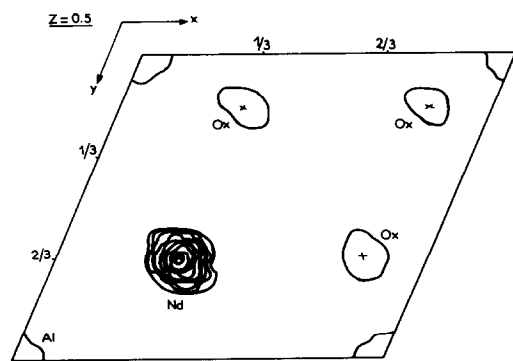

FIG. 3. Fourier map, section $z = 0.5$: neodymium organization.

TABLE II
FINAL ATOMIC PARAMETERS AND ISOTROPIC THERMAL FACTORS FOR $R = 0.049$

Independent atoms	Wyckoff position		Occup.	$x = -y$ (10^4)	z	B
	$\bar{P}6m2$	$P6_3/mmc$ corresp.				
Al ₁	6n	12k	1	-1686(8)	1470(1)	0.48(3)
Al _{1bis}	6n		1	1685(5)	-6390(1)	0.00(3)
Al ₂	2h	4f	1	3334(0)	2284(0)	0.10(6)
Al _{2bis}	2h		1	6667(0)	7203(2)	0.05(6)
Al ₃	2h	4f	1	3334(0)	755(2)	0.39(6)
Al _{3bis}	2h		1	6667(0)	5595(2)	0.00(6)
Al ₄	2g	2a	1	0(0)	2533(2)	0.13(6)
Al _{5bis}	(1b)/2g	(2b)/4e	1	0(0)	5086(4)	0.17(16)
O ₁	6n	12k	1	1564(9)	2043(2)	0.25(8)
O _{1bis}	6n		1	-1557(10)	6936(2)	0.23(8)
O ₂	6n	12k	1	-4986(12)	1053(3)	0.40(8)
O _{2bis}	6n		1	-5050(9)	5971(3)	0.20(8)
O ₃	2i	4f	1	6667(0)	2001(5)	0.20(10)
O _{3bis}	2i		1	3334(0)	6907(4)	0.00(10)
O ₄	2g	4e	1	0(0)	1104(6)	0.28(15)
O _{4bis}	2g		1	0(0)	5986(6)	0.30(18)
O ₅	(1c)/3j	(2c)/6h	1.15	2880(30)	0(0)	0.86(50)
O _{5bis}	3k	6h	1	-1803(14)	5000(0)	0.28(13)
Nd	(1d)/3k	(2d)/6h	0.9	3197(3)	5000(0)	0.48(3)
Na ₁	3j	6h	0.77	-1931(37)	0(0)	2.00(47)
Na ₂	(1e)/3j	(2b)/6h	0.53	9494(50)	0(0)	2.00(70)

Note. The Wyckoff positions in parentheses correspond to the expected theoretical site. Occupancy gives the total amount over one split site. Anisotropic thermal factors would reduce the errors on Na and O5 positions, but it is well known that, in such compounds, high thermal factors or delocalized atomic positions account for the same dynamic disorder.

An attempt was made to refine the cation occupancy factors in order to get the effective composition of our sample: a deficiency of Nd³⁺ (0.9 instead of 1) is detected.

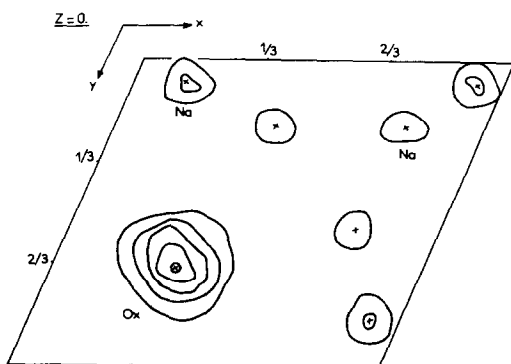

FIG. 4. Fourier map, section $z = 0$: sodium organization. (Electron density scale is different from that of Fig. 3.)

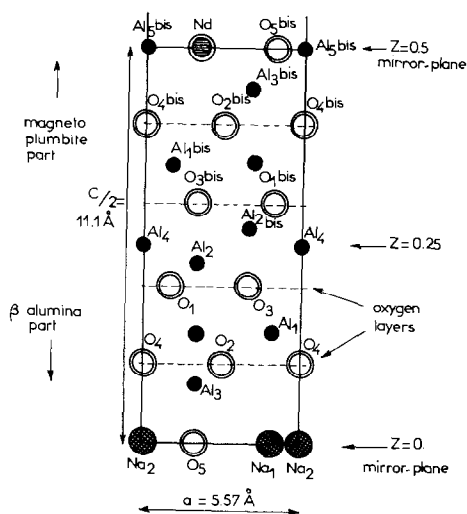

FIG. 5. Schematic projection of SNA structure on (a,c) plane (along b), showing the layers of oxygen and the correspondence between the two parts of the unit cell.

TABLE III
MAIN INTERATOMIC DISTANCES (IN ANGSTROMS) IN SNA WITH CORRESPONDING DISTANCES IN Na
 β -ALUMINA AND Nd MAGNETOPLUMBITE

Bond lengths in NaAl ₁₁ O ₁₇ (7)	Sodium-neodymium aluminate						Bond lengths in NdAl ₁₁ O ₁₈ (6)
	Half β -alumina unit cell			Half magnetoplumbite unit cell			
2.022	Al ₁	O1 × 2	2.024	Al _{1bis}	O _{1bis} × 2	1.983	1.996
1.837	octa	O2 × 2	1.842		O _{2bis} × 2	1.830	1.839
1.970		O3 × 1	1.979		O _{3bis}	1.963	1.960
1.819		O4 × 1	1.819		O _{4bis}	1.858	1.856
1.801	Al ₂	O1 × 3	1.789	Al _{2bis}	O _{1bis} × 3	1.815	1.819
1.809	tetra	O _{3bis}	1.801		O ₃	1.744	1.792
1.768	Al ₃	O2 × 3	1.752	Al _{3bis}	O _{2bis} × 3	1.855	1.850
1.677	tetra	O5	1.736	octa	O _{5bis} × 3	1.986	2.000
1.895		Al ₄		O ₁	× 3	1.862	1.889
		common to both unit cells		O _{1bis}	× 3	1.911	
				Al _{5bis}	O _{5bis} × 3	1.748	1.732
					O _{4bis}	2.005	2.004
					O _{4bis}	2.384	2.494
	Na ₁	O5	2.791	Nd	O _{5bis} × 2	2.681	2.783
		O5 × 2	2.447		O _{5bis} × 2	2.785	
		O2 × 4	2.778		O _{5bis} × 2	2.903	
		O4 × 2	3.085		O _{2bis} × 4	2.630	2.714
	Na ₂	O4	2.501		O _{2bis} × 2	2.742	
		O5	3.200				

For Na⁺, the total amount exceeds 1 and is allowed by the several available sites for Na⁺, as it is in β -alumina (7).

Refinement of Al³⁺ occupancy factors gave no improved value for the *R* factor, and the absolute composition of our SNA phase could not be deduced.

Assuming an ideal Al/O ratio in the spinel blocks, this compound would be close to Nd_{0.9}Na_{1.3}Al₂₃O_{36.15}. A balanced composition would be Nd_{0.9}Na_{1.3}Al₂₃O_{36.5}.

But Na⁺ and O²⁻ are not clearly discernable by X-ray study. Moreover, vacancies or interstitial atoms (Al³⁺ or O²⁻) are not easily detected in the structure and it is not yet possible to establish clearly the charge compensation mechanism required by an

excess of Na⁺ and the trivalent charge of Nd³⁺.

Crystal analyses by electron microprobe and neutron activation give rather consistent results for the composition, as far as the ratio Na/Nd is concerned.

Description of SNA Structure

The unit cell of SNA may then be described as an alternate stacking of a half β -alumina-like unit cell and a half magnetoplumbite-like unit cell. This is illustrated by the different occupation of the two mirror planes and by the environment of atoms which are in the neighborhood of these planes ($z = 0$ and 0.5) (Table III). Around

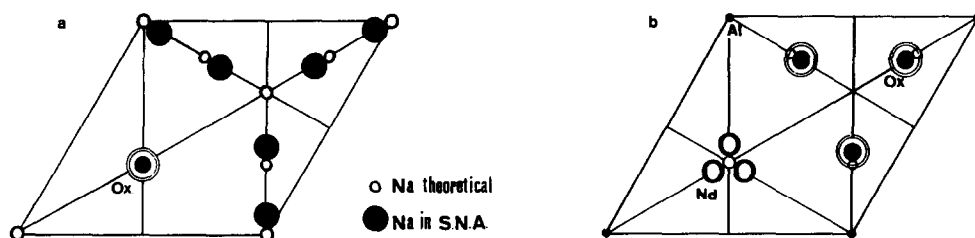

FIG. 6. (a) Theoretical (open circles) and actual (solid circles) distribution of Na^+ ions in the mirror plane at $z = 0$. (b) Distribution of ions in the mirror plane at $z = 0.50$. Small open circles are theoretical sites.

Nd^{3+} , the stacking is quite similar to that of Nd^{3+} hexaaluminate ($\text{NdAl}_{11}\text{O}_{18}$ (6)). Around Na^+ , the interatomic distances are close to those found in Na^+ β -alumina (7). But if Na^+ ions are still disordered and loosely packed they show a different arrangement (Fig. 6): in β -alumina (297 K), the crystallographic sites (2c) and (6h), corresponding to (1e) and (3j) Wyckoff positions in $P6m2$, are predominantly occupied (i.e., $\frac{2}{3}$, $\frac{1}{3}$, 0 and x , \bar{x} , 0). Here, in SNA, the (1e) site is empty and (1a) and (3j) positions which are 2b and 6h in $P6_3/mmc$ are partly occupied with a rather high disorder (the (1a) site is in fact split into a (3j) type of site).

The description of this mixed hexaaluminate is consistent with the physical properties which were studied at the same time. These properties come out from the two structural units that build SNA (5):

(1) The presence of Na^+ ion, which can easily diffuse in the loosely-packed planes of the structure, allows ionic exchange and high conductivity, as in β -alumina. The conductivity is lower but activation energy is lower too: the number of planes with conducting ions is twice smaller but these ions are more disordered and differently organized, and their diffusion requires less energy.

(2) The crystal field around Nd^{3+} in SNA

allows an optical behavior similar to that observed in Ln^{3+} hexaaluminates containing some Nd^{3+} (UV-visible spectroscopy).

These observations fit well with the model of two half unit cells of β -alumina and magnetoplumbite, in which the structure of sodium-neodymium aluminate was refined.

Acknowledgment

The high-resolution electron microscopy patterns were realized by Dr. Gratias, who is kindly acknowledged by the authors.

References

1. R. COLLONGUES, J. THERY, AND J. P. BOILOT, in "Solid Electrolytes" (P. Hagenmuller and W. Van Gool, Eds.), New York, Academic Press, 1978.
2. A. KAHN, A. M. LEJUS, M. MADSAC, J. THERY, D. VIVIEN, AND J. C. BERNIER *J. Appl. Phys.* **52**, 6864 (1981).
3. D. VIVIEN, J. THERY, R. COLLONGUES, J. AUBERT, R. MONCORGE, AND F. AUZEL, *C.R. Acad. Sci.* **298**, 195 (1983).
4. J. P. BARRET, D. VIVIEN, AND J. THERY, *Mat. Res. Bull.* **18**, 59 (1983).
5. A. RAFAOUI, A. KAHN, J. THERY, AND D. VIVIEN, *Solid State Ionics* **9-10**, 331 (1983).
6. N. IYI, Z. INOUE, AND S. KIMURA, *J. Solid State Chem.* **54**, 123 (1984).
7. C. R. PETERS, M. BETTMAN, J. W. MOORE, AND D. GLICK, *Acta Crystallogr. Sect. B* **27**, 1827 (1971).