

Up-Conversion Yield in Glass Ceramics Containing Silver

O. L. MALTA*

CNRS, E.R. 210, 1, place Aristide Briand, 92195 Meudon-Bellevue, France

P. A. SANTA-CRUZ AND G. F. DE SÁ

Departamento de Química Fundamental, Departamento de Física da UFPE, Cidade Universitária, Recife PE-50730, Brasil

AND F. AUZEL

CNET, 196 rue H. Ravera, 92220 Bagneux, France

Received August 4, 1986; in revised form October 1, 1986

Small silver particles are known to increase the fluorescence yield in rare-earth-doped glasses. These particles can be grown easily in glass ceramics of general composition (PbF_2 , GeO_2 , YbF_3 , ErF_3). We have studied the effect of the addition of silver on the up-conversion yield due to sequential energy transfer between Yb^{3+} and Er^{3+} ions. The origin and the information that can be obtained from this effect are discussed. © 1987 Academic Press, Inc.

1. Introduction

Inorganic amorphous materials have been shown to be very useful as host media in which small metallic particles can be grown. The growth of these particles as well as their optical properties may then be studied (1–5). These composite media can subsequently be used in the study of the effect of the plasmons, localized in the small metallic particles, on the absorption and emission processes in molecules or ions contained in the amorphous material (6–8).

Recently, a class of nonlinear processes, which includes up-conversion of light by

energy transfer, under the influence of small metallic particles has been analyzed theoretically (8). In particular, it was concluded that in the case of up-conversion by sequential energy transfer the effect, at resonance, of the plasmons in the metallic particles is to quench the emission corresponding to the up-converted radiation. One may, therefore, use this effect to get information about the spectral position of the Mie resonance in the metallic particles in a given medium, particularly in the case of glass ceramics in which the up-conversion phenomenon is known to be very efficient (9) and in which the usual spectroscopic measurements cannot be carried out because of the opacity of the material. Also, due to the high sensitivity of the phonon-assisted energy transfer rates to the medium, structural information may be obtained.

* On leave of absence from Departamento de Química Fundamental da UFPE, Cidade Universitária, Recife PE-50730, Brasil.

In this work we have studied the up-conversion by sequential energy transfer between Yb^{3+} and Er^{3+} ions in glass ceramics containing silver.

2. Experimental Results

Glass ceramics of general composition (PbF_2 , GeO_2 , YbF_3 , ErF_3 , AgNO_3) were prepared with doping concentrations by weight: 10% Yb, 5% Er, 0 and 3% Ag. Initially the glass ceramics were not annealed. Powder with grains of approximately the same size were made from these samples and fixed, homogeneously, on a Scotch tape for measurement purposes. The glass ceramic without silver (0% Ag) was taken as the reference sample.

In contrast to the case of glasses, metallic silver migrates to the glass ceramic surface when annealed for about 4 hr (the powder sample was then prepared from the bulk of the material). This indicates a relatively easy diffusion of neutral silver atoms and consequently a high rate of formation of silver particles. Actually, we expect that silver particles are nucleated while the glass ceramic is cooled from melting temperature

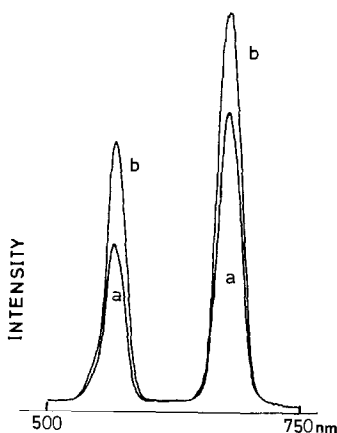

FIG. 1. Green and red emission, from Er^{3+} ions, following up-conversion of the 960 nm radiation in the glass ceramic without silver (0% Ag). (a) without annealing; (b) annealing for 4 hr.

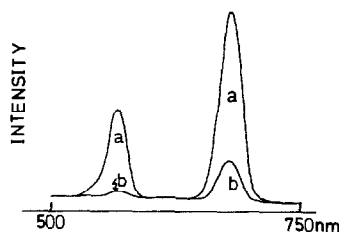

FIG. 2. Green and red emission, from Er^{3+} ions, following up-conversion of the 960 nm radiation in the 3% Ag glass ceramic. (a) without annealing; (b) annealing for 4 hr.

to room temperature. Due to the opacity of the medium, the plasmon absorption band cannot be detected.

Luminescence following excitation with a pump flux at 960 nm from a GaAs:Si diode was detected by a water-cooled RCA-C31034-02 photomultiplier, processed by a Spex Datamate DM-1 lock-in amplifier, and displayed on a strip-chart recorder. Because we wish to compare emission yields originating from a nonlinear effect, the shape and position of the samples with respect to the diode are crucial factors. These were taken into consideration in checking the reliability of our results.

Figure 1 shows the green (560 nm) and red (670 nm) emission following up-conversion of the 960 nm radiation for the glass ceramic without silver. By comparing spectra a and b we can see that the emission yield increases when annealed at 400°C for about 4 hr. We also notice that the ratio between the red and green emission yield decreases.

Figure 2 shows the spectra corresponding to those in Fig. 1 for the glass ceramic containing 3% Ag by weight. In this case we see an opposite behavior only, that is, the emission yield decreases when annealed at 400°C for about 4 hr. Opposite behavior is also noticed with respect to the ratio between the red and green emission yields.

These trends are also observed for the red emission following excitation with the

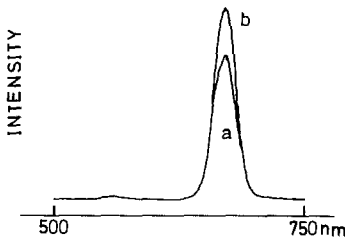

FIG. 3. Red emission, from Er^{3+} ions, following stepwise absorption of the 1500 and 960 nm photons in the glass ceramic without silver (0% Ag). (a) without annealing; (b) annealing for 4 hr.

diode (960 nm) plus 1500 nm radiation from a halogen lamp filter system. In this case up-conversion may take place by the stepwise absorption of the 1500 and 960 nm photons. A chopper coupled to the lock-in was used in order to eliminate the red and green contributions to the emission originating from up-conversion, by energy transfer, of the 960 nm radiation. These results are shown in Figs. 3 and 4.

The intensity scale of the spectra in Figs. 1–4 is the same; this allows direct evaluation of their relative intensities. It should be noticed from them that, independent of annealing, the emission yield decreases in the presence of silver.

We have also measured the lifetimes of the red emission from samples both with and without silver. The experimental setup was the same as in Ref. (10), the excitation source being the diode coupled to a pulse generator. As expected, the lifetime is shortened in the presence of silver. The decay curves are shown in Fig. 5.

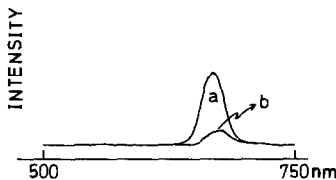

FIG. 4. Red emission, from Er^{3+} ions, following stepwise absorption of the 1500 and 960 nm photons in the 3% Ag glass ceramic. (a) without annealing; (b) annealing for 4 hr.

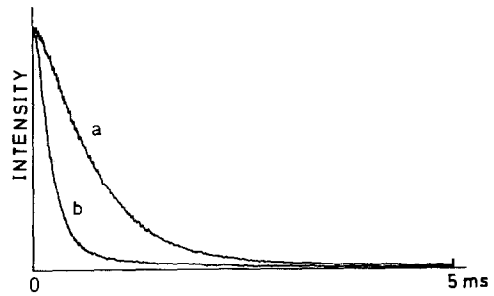

FIG. 5. Decay curves of the red emission, from Er^{3+} ions, in the (a) absence and (b) presence of silver particles. The observed lifetimes are 0.654 and 0.238 msec, respectively.

3. Discussion

Consider the scheme for the well-known up-conversion by sequential energy transfer between Yb^{3+} and Er^{3+} ions. This is shown in Fig. 6. When only the 960 nm radiation is present the $^4\text{S}_{3/2}$ and $^4\text{F}_{9/2}$ manifolds are populated through nonradiative decays following deexcitation of the $^4\text{F}_{7/2}$ level. If the 1500 nm radiation is added a second channel of population of the $^4\text{F}_{9/2}$ level is opened through up-conversion by summation of the 1500 and 960 nm photons.

In order to understand the behavior of the green and red emission as described in

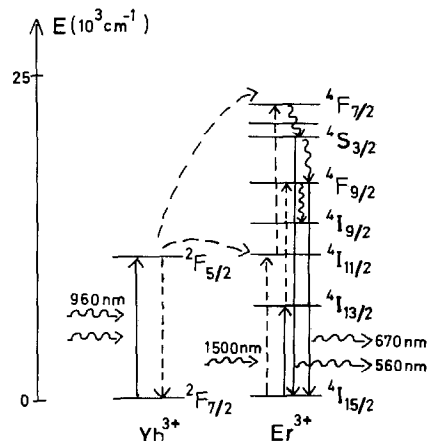

FIG. 6. Energy level scheme and the up-conversion processes in the Yb^{3+} – Er^{3+} pair.

the preceding section, we consider the following effects:

(i) Losses in the pump flux due to scattering of radiation by the silver particles.

(ii) Quenching due to energy transfer from Er^{3+} ions to silver particles.

(iii) Variation of the up-conversion yield as a function of the maximum phonon frequency of the host.

The first one can be discarded on the following grounds. Even though the effective pump flux inside the sample might be reduced, due to scattering of radiation by the silver particles, the concentration of rare-earth ions in the region between silver particles is greater than in the reference sample (0% Ag) provided the number of absorbing and emitting species is fixed. This compensates for the reduction in the effective pump flux. Moreover, for the excitation power used here there would be no apparent reason why the green and red emission yields should change differently since both are directly proportional to the square of the pump flux.

Quenching due to energy transfer from Er^{3+} ions to the silver particles may be a plausible explanation for our results. This would give us the spectral region of the plasmon absorption band since energy transfer toward the silver particles takes place at resonance conditions (7). The fact that the emission yield, as shown in Fig. 2, decreases when the 3% Ag sample is annealed could be explained by an increase of the specific volume of silver particles.

There are, however, some arguments against this explanation. First, in the present case quenching due to energy transfer from Er^{3+} ions to silver particles would require a plasmon band peaked in the region 500–600 nm. This may occur when there is a strong correlation between the particles due to very high values of their specific volume but this is unexpected, as confirmed by the available data on the ab-

sorption by small silver particles in glass materials (see Refs. (4, 6) and references therein), for low-specific-volume values. This latter should correspond to our case due to the relatively low initial silver concentration. Second, a plasmon band in this spectral region would probably modify certain sample characteristics, for example, their colors. However, no changes in this direction were observed. Third, this quenching process is in general quite efficient (7). Thus, at resonance or near resonance we would expect an effect on the emission yield much more significant than observed though it could be argued that even with a plasmon band peaking above the ${}^4F_{7/2}$ level, in such a way that the energy mismatch is far from resonance, some quenching could still exist. However, in this case, when the ${}^4F_{9/2}$ level, which lies at $\sim 5000 \text{ cm}^{-1}$ below the ${}^4F_{7/2}$ one, is directly populated through the stepwise absorption of the 1500 and 960 nm photons the decrease in the red emission yield should be much less pronounced than observed from Figs. 3 and 4 or, in other words, it should not be comparable with the decrease observed from Figs. 1 and 2.

Finally, a second plausible explanation for our results is the dependence of the up-conversion yield on the maximum phonon frequency of the host. This is a consequence of the dependence of the phonon-assisted energy transfer and nonradiative decay rates on the phonon density of states. Thus, for example, the up-conversion green emission yield in Er^{3+} versus the maximum phonon energy of the host peaks at about 360 cm^{-1} and decreases by more than an order of magnitude for maximum phonon energies lower than 250 cm^{-1} and higher than 650 cm^{-1} (11, 12). The glass ceramics have maximum phonon energies around 360-cm^{-1} while in the case of glasses the maximum phonon energy lies far above this value. This well-known fact explains the high efficiency of up-conversion in glass ce-

ramics in contrast to the case of glasses. The results described in the preceding section may be, therefore, rationalized if we assume that the material containing silver has the maximum phonon frequency displaced toward higher values.

A direct proof of a modification of the maximum phonon frequency is given by the Raman spectra shown in Fig. 7.

By comparing the spectra obtained from the samples with and without silver, it may be noted that a broad vibrational band extending from 850 to 1750 cm^{-1} appears when silver is introduced. This band lies just above the 800 cm^{-1} peak characteristic of the Ge-O vibration and below the luminescence band at 520 nm which appears here at 1800 cm^{-1} from the excitation laser (Argon laser at 476 nm). The wide band introduced by silver can be attributed to several vibrational modes due to NO_3^- at 1042 cm^{-1} , NO_2 at 1240 cm^{-1} , and the nitrite radical at 1330 cm^{-1} (13, 14). Also, depending on the complex, N-O modes have been observed in the range 1100 to 1455 cm^{-1} (13). So, such a band can be attributed to different states of the nitrate decomposition before obtaining metallic silver which coexists between the Ag^+NO_3^- phase and the Ag^0 one.

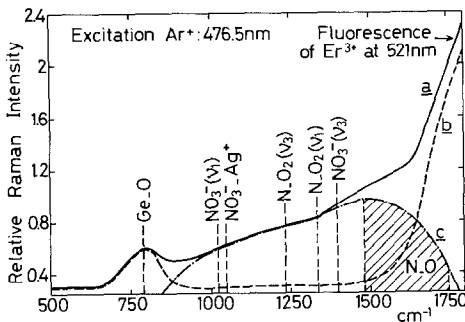

FIG. 7. Raman spectra for the sample containing silver (a) and for the reference sample without silver (b); curve c is the difference between spectra a and b, showing the undesired incorporation of the radicals NO, NO_2 , and NO_3 as indicated by the new Raman band.

The explanations of our results based on either effect (ii) or (iii) incorporate the fact that the green and red emission yields undergo different variations since the populations of the $^4\text{S}_{3/2}$ and $^4\text{F}_{9/2}$ levels do not depend on the energy transfer and nonradiative decay rates in the same manner.

4. Conclusion

Our results indicate that small silver particles can be grown easily in glass ceramics. The effect of these particles on up-conversion by sequential energy transfer can be manifested via quenching, due to energy transfer from the emitting ions to the plasmons localized in the silver particles. This mechanism is significant only when resonance is achieved. This would require, in our case, a plasmon absorption band peaking around 600 nm, which would be uncommon. Also, in this case, energy transfer to the silver particles would take place quite efficiently. This prediction does not seem to agree with our observations. Therefore, it is likely that the plasmon band lies far above the $^4\text{F}_{7/2}$ level of Er^{3+} (20900 cm^{-1}).

Thus, our interpretation points to the variation of the maximum phonon frequency of the medium, due to the presence of silver, as the effect responsible for the behavior of the up-conversion yield described in Section 2.

Acknowledgments

The authors are grateful to Mrs. C. Meriadec for technical help in obtaining the Raman spectra on the MOLE at CNET and to the CNPq (Brazilian Agency) for financial support.

References

1. S. D. STOOKEY, *J. Amer. Ceram. Soc.* **32**, 246 (1949).
2. R. D. MAURER, *J. Appl. Phys.* **29**, 1 (1958).

3. R. H. DOREMUS, *J. Chem. Phys.* **42**, 414 (1965).
4. U. KREIBIG AND C. V. FRAGSTEIN, *Z. Phys.* **224**, 307 (1969).
5. C. R. BERRY AND D. C. SKILLMAN, *J. Appl. Phys.* **42**, 2818 (1971).
6. O. L. MALTA, P. A. SANTA-CRUZ, G. F. DE SÁ, AND F. AUZEL, *J. Lumin.* **33**, 261 (1985).
7. O. L. MALTA, *Phys. Lett. A* **114**, 195 (1986).
8. O. L. MALTA, *Phys. Lett. A* **114**, 198 (1986).
9. F. AUZEL, *Proc. IEEE* **61**, 758 (1973).
10. F. AUZEL, P. A. SANTA-CRUZ, AND C. F. DE SÁ, *Rev. Phys. Appl.* **20**, 273 (1985).
11. F. AUZEL, in "Proceedings, Int. Symp. Rare Earth Spect., Wroclaw, Poland, 1984."
12. F. AUZEL, in "Luminescence of Inorganic Solids" (B. di Bartolo, Ed.), p. 109, Plenum, New York (1978).
13. D. M. ADAMS, "Metal-Ligand and Related Vibrations," Arnold, London (1967).
14. E. F. RIEBLING, *J. Mater. Sci.* **7**, 40 (1972).