

New Results on the Phase Transformations of In_2Se_3

C. MANOLIKAS

Department of Physics, Section of Solid State Physics, Aristotles University of Thessaloniki, Thessaloniki 540 06, Greece

Received July 27, 1987; in revised form December 14, 1987

The various phases and the phase transformations of In_2Se_3 are studied by electron microscopy and electron diffraction methods. Specimens from crystal slices perpendicular to the hexagonal basal plane were used. The results were combined with those reported by J. van Landuyt *et al.* (1) for specimens parallel to the basal plane. It is found that the various $\alpha(n)$ -polytypic forms of In_2Se_3 follow similar transformation paths by heating above room temperature. The ultimate δ -phase is cation disordered with a wurtzite-like average structure. Apart from the γ -phase, the intermediate phases are characterized by highly faulted sequences of structure sheets along the c -axis. © 1988 Academic Press, Inc.

1. Introduction

Indium selenide has already been studied by means of electron microscopy and electron diffraction methods by van Landuyt *et al.* (1). Since, however, it is a layered compound their studies were limited to the hexagonal basal plane. In this work the study is extended to planes which include the c -axis. The results give more information about the various phases indium selenide exhibits at room, higher, and lower temperatures and solve some problems concerning its phase transitions.

The structures of the various phases of indium selenide have been studied by many authors (2-7), the results, however, are different and in many cases contradictory. According to Likforman *et al.* (7), four hexagonal or rhombohedral polytypic forms of In_2Se_3 exist at room temperature, noted as $\alpha(n)$ with $n = 1, 2, 3, 4$. Their lattice parameters are $a_n = a_1$ and $c_n = nc_1$ with $a_1 = 4.00 \text{ \AA}$ and $c_1 = 9.56 \text{ \AA}$.

According to Osamura *et al.* (5), the structure of the $\alpha(3)$ -polytype consists of rhombohedral alternate of fivefold sheets Se-In-Se-In-Se , which are again packed rhombohedrally forming a repetition of $AbCaA \cdot BcAbB \cdot CaBcC$ (Fig. 1a). Semiletov (3) on the other hand has suggested a different model for the $\alpha(2)$ -polytype which consists also of fivefold sheets but packed hexagonally, forming the repetition $AcCaA \cdot BaAbB$ (Fig. 1b).

Above 200°C the β -phase is formed (1, 7). Although the phase transition is reversible a considerable hysteresis appears on cooling, which has been attributed by van Landuyt *et al.* (1) to the formation of an intermediate β' -phase below 200°C and above 60°C . Further heating above 350°C leads irreversibly to the formation of γ -phase, which is also hexagonal but not layered (6). Its lattice parameters are $a = 7.11 \text{ \AA}$ and $c = 19.3 \text{ \AA}$, i.e., $a \approx a_1\sqrt{3}$ and $c \approx 2c_1$, and the structure can be considered to be a distorted wurtzite-like structure with

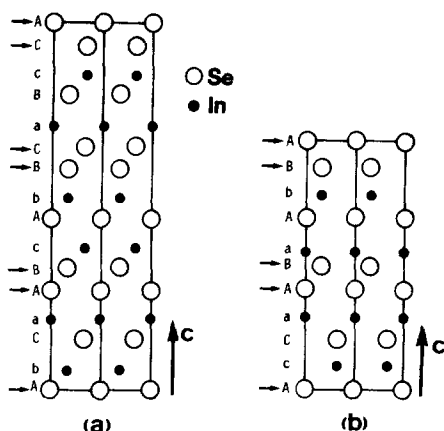
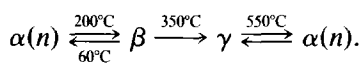

FIG. 1. (a) Model for the structure of the $\alpha(3)$ -polytype (after Ref. (5)). (b) Model for the structure of the $\alpha(2)$ -polytype (after Ref. (3)). Note that in the first model indium occupies octahedral and tetrahedral interstices, whereas in the second one indium occupies only tetrahedral interstices.

In atoms either tetrahedrally or pentagonally coordinated (6).

According to Likforman *et al.* (7), by heating the γ -phase above 550°C , the $\alpha(n)$ -phase is reversibly formed, which can also be quenched to room temperature. They suggest the following sequence for the phase transitions of In_2Se_3 :



van Landuyt *et al.* (1), on the other hand, have found a new α' -phase on cooling below -125°C , with lattice parameters \bar{a} and \bar{b} related to \bar{a}_1 , \bar{a}_2 , \bar{a}_3 of the α -phase by

$$\bar{a} = \bar{a}_1 - \bar{a}_2 \quad \text{and} \quad \bar{b} = -2\bar{a}_3.$$

According to them the phase transitions of In_2Se_3 are summarized in the following scheme:

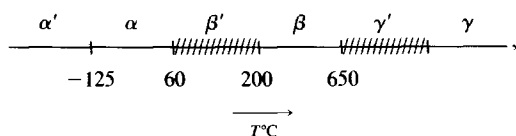

where the primed structures are assumed to be deformation-modulated versions of the unprimed ones.

2. Specimen Preparation

Indium selenide was synthesized by reaction of a stoichiometric mixture of the elements in an evacuated, sealed quartz tube at 600°C . Single crystals were grown by melting this material at 1150°C , followed by slow cooling to room temperature. In this way layered crystals of the $\alpha(2)$ and $\alpha(3)$ polytypic forms were obtained. Annealing of such crystals at about 400°C for a few hours led to formation of crystals exhibiting the γ -phase.

Specimens suitable for electron microscopic observations were obtained by repeated cleavage in the case of the layered crystals, by using an ion beam thinner in the case of cross sections of the former crystals (8), or even by scraping crystals of the γ -phase with a knife and gluing small flakes on grids (9).

3. Observations

3.1 The α -phase

Although Likforman *et al.* (7) have reported the existence of four polytypic forms of the α -phase differing in the c parameter, only two of them, the $\alpha(2)$ and $\alpha(3)$, are frequently observed in crystals. Electron diffraction patterns of them, corresponding to the basal plane and perpendicular to that plane are reproduced in Fig. 2. In accordance with the literature data the first polytype is hexagonal and the second one is rhombohedral with c parameters 19.2 and 28.7 \AA , respectively. Some authors have linked the formation of these two polytypic forms with the growth conditions (10). I have not been able to find any such correlation. The $\alpha(2)$ or the $\alpha(3)$ forms were grown independently of the growth condi-

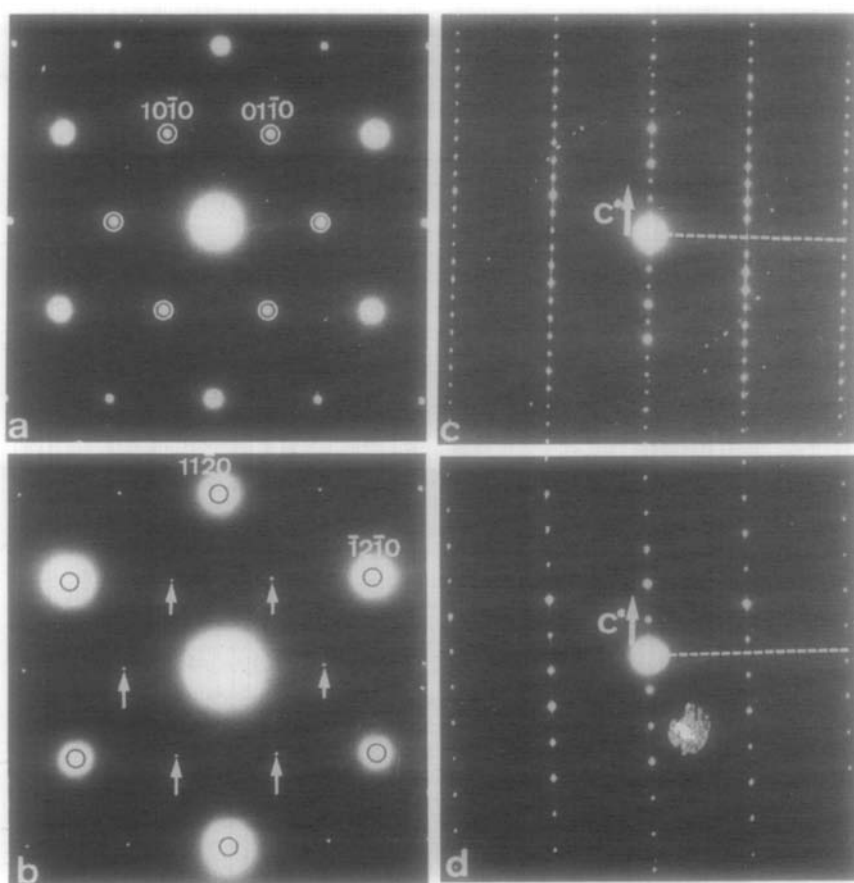

FIG. 2. Diffraction patterns of the hexagonal 0001^* section (a,b) and the $10\bar{1}0$ section (c,d). (a and c) The hexagonal $\alpha(2)$ -polytype. (b and d) The rhombohedral $\alpha(3)$ -polytype. The presence of spots shown by arrows in (b) are due to the elongation of the Bragg spots parallel with the c^* -axis, because of the stacking faults in the sequence of Se–In–Se–In–Se sheets.

tions. Small deviations from stoichiometry seem also to have no influence on the polytypic form grown. The phenomenon belongs to the general problem of polytypism in crystals, for which several different explanations have been put forth (11).

Very rarely, traces of higher $\alpha(n)$ -polytypes have been observed in some crystals. Figure 3 shows the diffraction pattern from a region which includes one such higher polytypic form in coexistence with the $\alpha(2)$ form. As it is deduced from the diffraction pattern, this higher polytype must

be rhombohedral with $c = 155.5 \text{ \AA}$, i.e., $c \approx 12c_1$. Lattice images of the $\alpha(12)$ - and the $\alpha(2)$ -polytypes, taken with diffraction spots of the central row, are compared in Fig. 4.

3.2 The $\alpha \rightarrow \beta$ -phase Transformation

As it has already been reported by many authors, when the α -phase is heated, a phase transformation occurs at about 200°C . van Landuyt *et al.* (1) have observed motion of partial dislocations in the electron microscopic images of the basal plane during this transformation and also

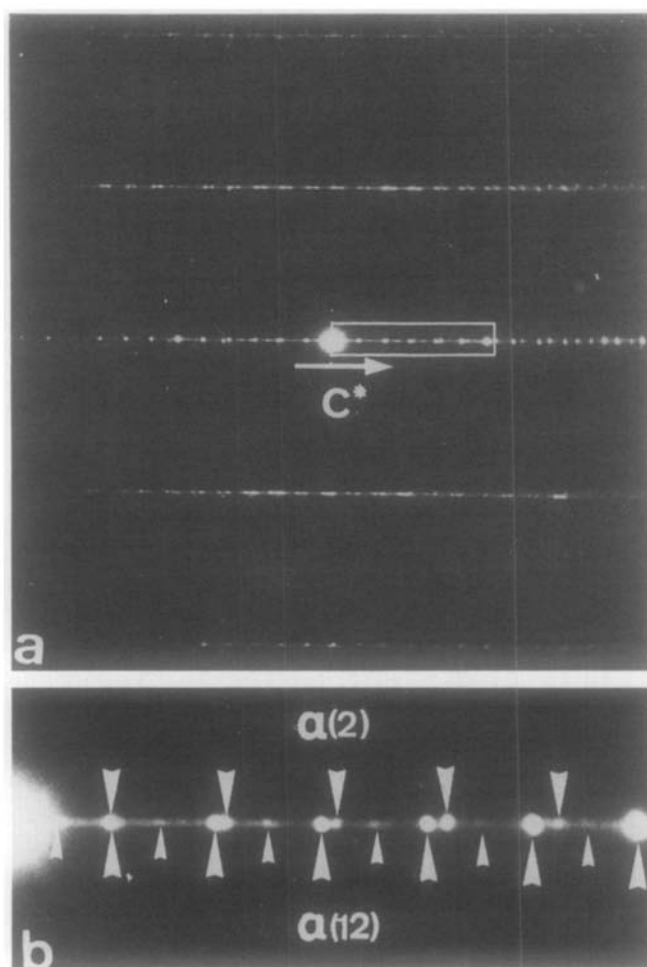

FIG. 3. (a) Diffraction pattern from region which includes the $\alpha(2)$ and $\alpha(12)$ polytypes. (b) Magnified image of part of the central row of (a). The upper arrows indicate the positions of the $\alpha(2)$ spots and the lower ones those of the $\alpha(12)$ spots.

nonradial diffuse lines passing through the spots in the corresponding diffraction patterns (Fig. 5a).

My electron microscopic observations along sections passing through the c -axis reveal that disorder in the sequence of the Se-In-Se-In-Se sheets must occur in both the polytypic forms $\alpha(2)$ and $\alpha(3)$ at the transition temperature. The β -phase existing above 200°C must therefore be considered as a phase with highly faulted se-

quences of the Se-In-Se-In-Se sheets along the c -axis.

3.3 The $\beta \rightarrow \beta'$ -phase Transformation

On cooling below 200° , β -phase is not transformed directly to the α -phase. As has been suggested by van Landuyt *et al.* (1), an intermediate β' -phase is formed between 200 and 60°C . At 60°C transformation to the original α -polytype takes place, but sometimes, especially in very thin specimens,

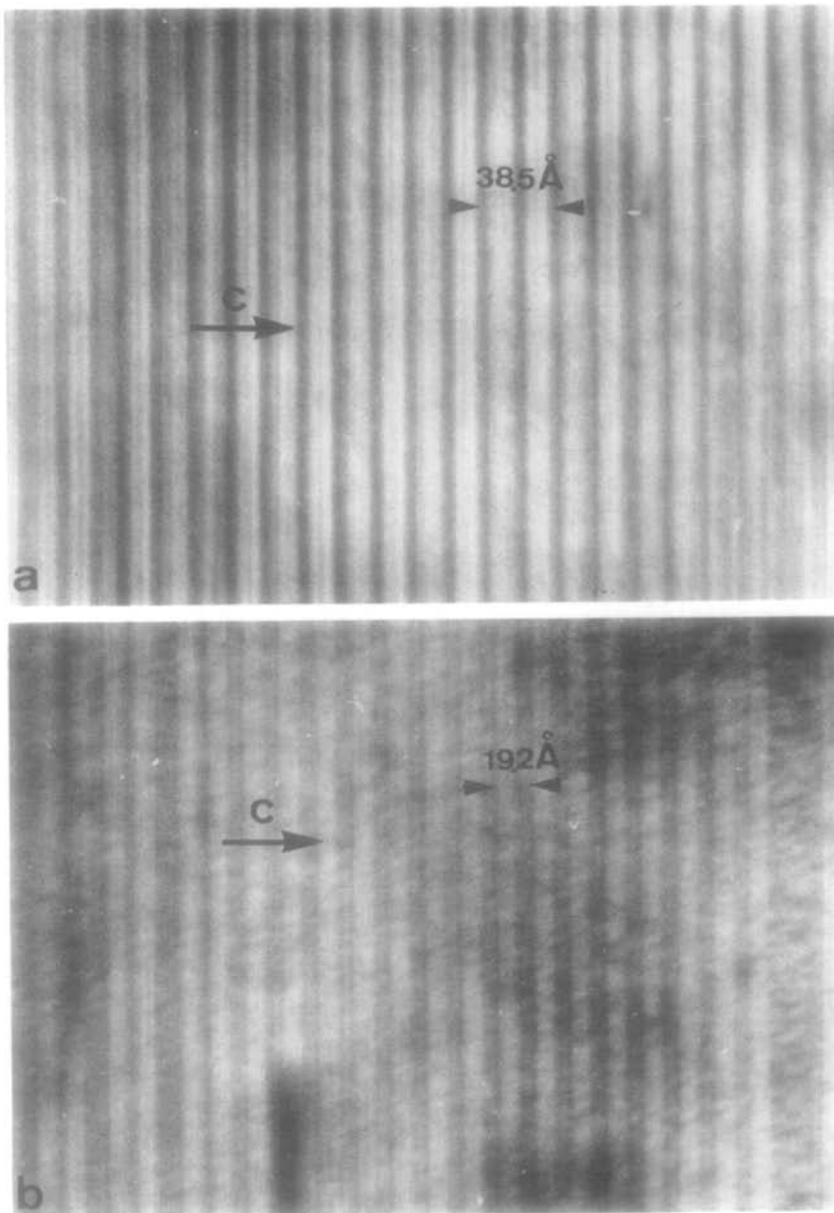

FIG. 4. Lattice images taken with spots of the central row (a) of the $\alpha(12)$ -polytype and (b) of the $\alpha(2)$ -polytype. The true c parameter of the rhombohedral $\alpha(12)$ -polytype is $3 \times 38.5 \text{ \AA} = 115.5 \text{ \AA}$.

this transformation is blocked and the β' -phase remains as a metastable phase at room temperature.

The main features of this intermediate

phase are the breaking of crystals into domains differing 120° in orientation and the appearance in the corresponding diffraction patterns of eight or nine equidistant diffrac-

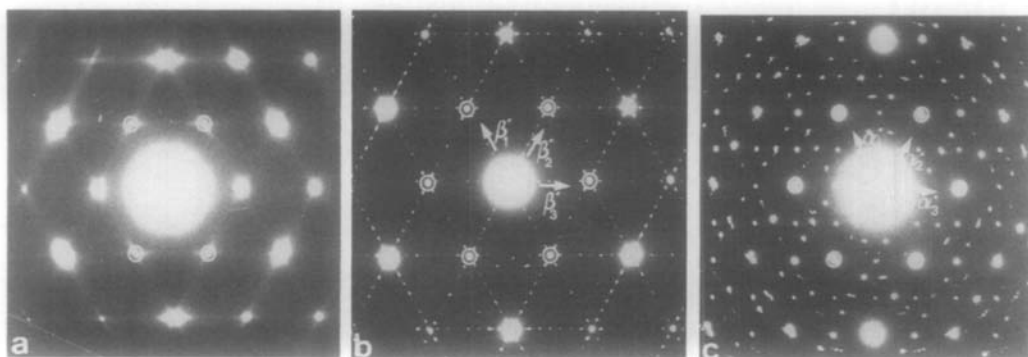

FIG. 5. Sequence of the diffraction patterns on cooling very thin regions of In_2Se_3 from above 200°C . (a) β -phase, (b) β' -phase, (c) α' -phase. In (b) and (c) three orientation variants differing 120° in orientation are included.

tion spots, between the main spots and along one of the three hexagonal directions (Figs. 5b, 6a, and 6c).

Although it has not been unambiguously justified, it appears that the $\alpha(2)$ - and $\alpha(3)$ -polytypes preferentially form the $8a_1$ and $9a_1$ β' -phase, respectively. Nevertheless, as reported by van Landuyt *et al.* (1), a mixing of the two superstructures is sometimes observed, yielding incommensurate phases. As is revealed from the streaks along the c^* -axis, in diffraction patterns corresponding to perpendicular of the basal plane sections (Figs. 6b and 6d), disordering of Se–In–Se–In–Se sheets along the c -axis persists in the β' -phase.

3.4 The $\beta' \rightarrow \alpha'$ -phase Transformation

When β' -phase is cooled to room temperature, it is normally transformed to the original α -polytypic form. Only in very thin regions of the crystal does the β' -phase remain as a metastable phase at room temperature. The same effect has already been observed by Popovic *et al.* (10) in powdered In_2Se_3 using X-ray diagrams.

Crystals exhibiting this metastable β' -phase at room temperature are transformed to the α' -phase at about -120°C . This phase is also orthorhombic and exhibits

three variants differing 120° in orientation (1). It is remarkable that the α' -phase is formed independently of the original α -polytypic form, i.e., the thermal behavior of the $\alpha(2)$ and $\alpha(3)$ polytypic forms seems to be quite similar.

Diffraction patterns of the basal and perpendicular planes from a single domain of the α' -phase from crystal having the $\alpha(2)$ -phase as the original one, are reproduced in Fig. 7 (see also Fig. 5c). As it is revealed from Fig. 7b, disordering along the c -axis still exists in this phase. Actually the sharp spots appearing on the basal plane (Fig. 7a) are due to the intersection of the Ewald's sphere with the streaked lines parallel with the c^* -axis (Fig. 7b).

3.5 The $\gamma \rightleftharpoons \delta$ -phase Transformation

Annealing of any $\alpha(n)$ -polytypic form at temperature above 350°C , leads to formation of the γ -phase. Diffraction patterns of this phase are shown in Figs. 8a–8c. As was stated by Likforman *et al.* (6), the γ -phase exhibits a deformed, defect wurtzite-like superstructure with lattice parameters $a_\gamma = a_0\sqrt{3}$ and $c_\gamma = 6c_0$, where $a_0 = 4.00 \text{ \AA}$ and $c_0 = 3.18 \text{ \AA}$ are the lattice parameters of the hexagonal basic structure.

Heating of the γ -phase at about 550°C

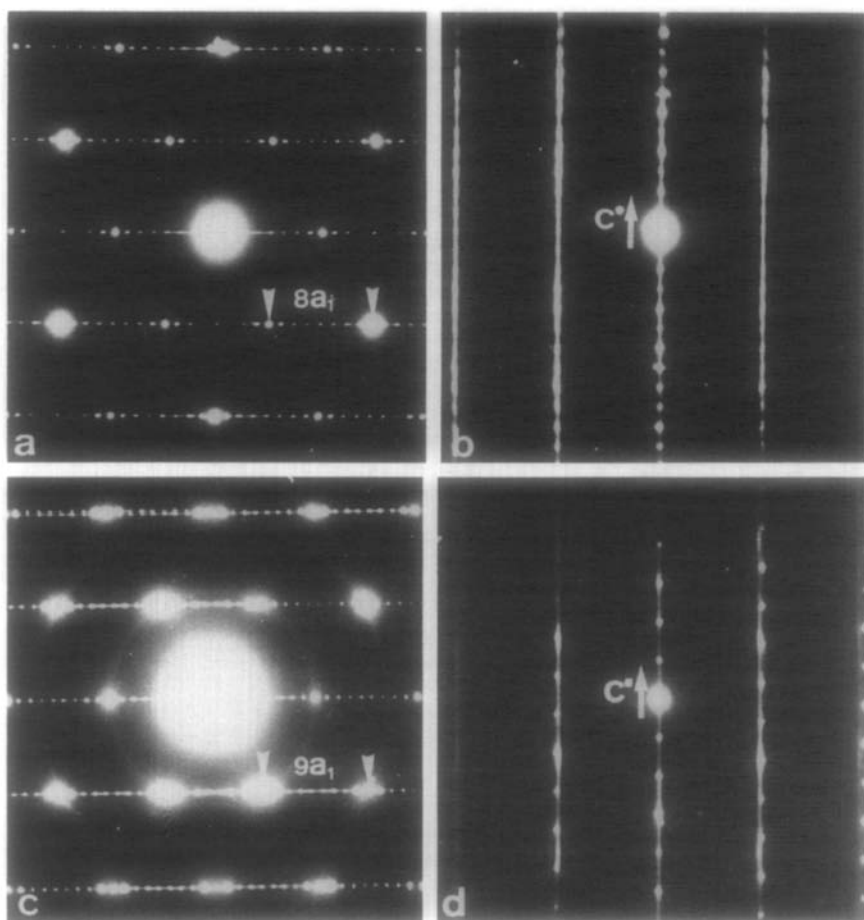

FIG. 6. Diffraction patterns of the modulated β' -phase. The original polytypic form is the hexagonal $\alpha(2)$ in (a,b) and the rhombohedral $\alpha(3)$ in (c,d). Note that the modulation on the basal plane is $8a_1$ in (a) and $9a_1$ in (c). The streaking of the spots along the c^* -axis (b,d) reveals the highly faulted sequence of Se–In–Se–In–Se sheets along the c direction.

leads to broadening of the superstructure spots (Fig. 8d), which further elongate toward the c^* -axis and finally disappear. Obviously disordering of the In cations among the interstitial sites of the Se sublattice takes place at this temperature. The diffuse scattering indicates the passage of the crystal through the corresponding “transition state” (12).

Most presumably the average structure of this disordered δ -phase is of wurtzite

type, with Se layers following the $ABAB \dots$ sequence and In cations statistically distributed over tetrahedral interstices. It is clear that this is a new phase, different from any $\alpha(n)$ -polytypic form. Nevertheless it can be considered as the original structure of the various $\alpha(n)$ -polytypes, which are formed by rearrangement of the layers in relatively fast cooling of the crystal whereas the γ -phase is reformed by slow cooling.

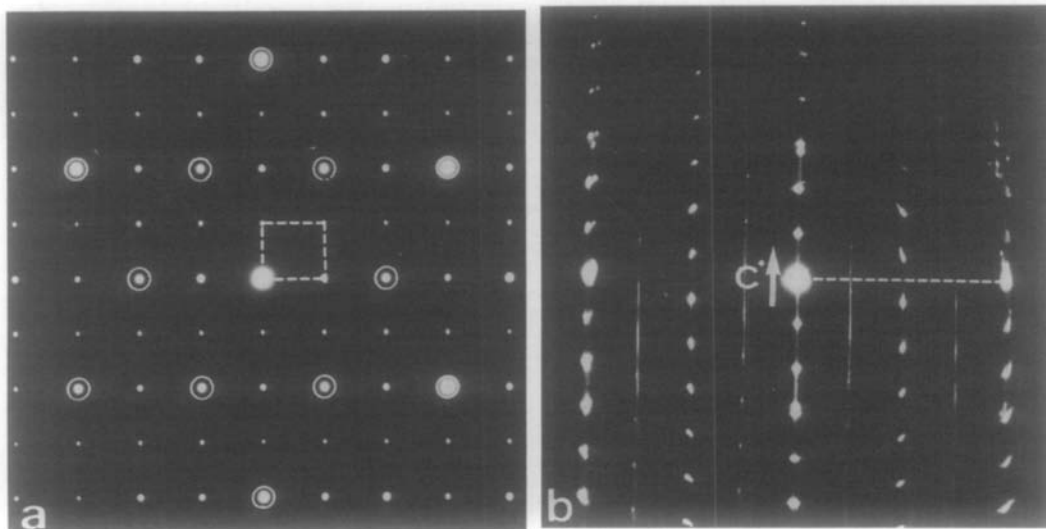

FIG. 7. Diffraction patterns of the α' -phase, having the $\alpha(2)$ -polytype as the original one. (a) 0001^* section, (b) $10\bar{1}0^*$ section. The extra spots appearing on the basal plane correspond to lines parallel to the c^* -axis.

4. Discussion and Conclusions

As was mentioned under Introduction, the structure of the $\alpha(n)$ -polytypes has not been unambiguously determined as yet. In the model for the $\alpha(3)$ -polytype suggested by Osamura *et al.* (5), indium cations are distributed over tetrahedral and octahedral interstices, whereas in that of $\alpha(2)$ -polytype, Semiletov (3) restricts indium cations to tetrahedral interstices only.

It is clear from my results that the general behavior of the $\alpha(2)$ -polytype is similar to the $\alpha(3)$ one, concerning at least their phase transformations. It certainly reflects a similarity in the structure as well, which presumably consists of the *same* fivefold sheets, Se–In–Se–In–Se, packed differently in the various polytypes, i.e., hexagonally in $\alpha(2)$, rhombohedrally in $\alpha(3)$, and in a mixed way in higher polytypes.

Osamura (5) has also suggested a structural model of the β -phase. It exhibits the same sequence of Se layers as the $\alpha(3)$ -polytype, but with indium cations occupy-

ing only octahedral interstices. My electron diffraction observations reveal that the β -phase is formed independently of the starting $\alpha(n)$ -polytype and though it retains some features of the later, it is highly faulted along the c -axis.

Most presumably the accumulation of these faults triggers the creation of the transverse acoustical mode on the basal plane, to which the appearance of the non-radial diffuse scattering in diffraction patterns of β -phase has been attributed by van Landuyt *et al.* (1). As was postulated by these authors, freezing of the acoustical mode, on cooling below 200°C , leads to formation of the $8a_1$ or $9a_1$ modulated β' -phase, which presents similar disorder of the sheets along the c -axis as the β -phase. Restoration of the original sequence of the sheets occurs on cooling below 60°C . This is accompanied by disappearance of the former modulation and formation of the original $\alpha(n)$ -polytype. However, in very thin specimens the disorder and therefore the modulated β' -phase are conserved be-

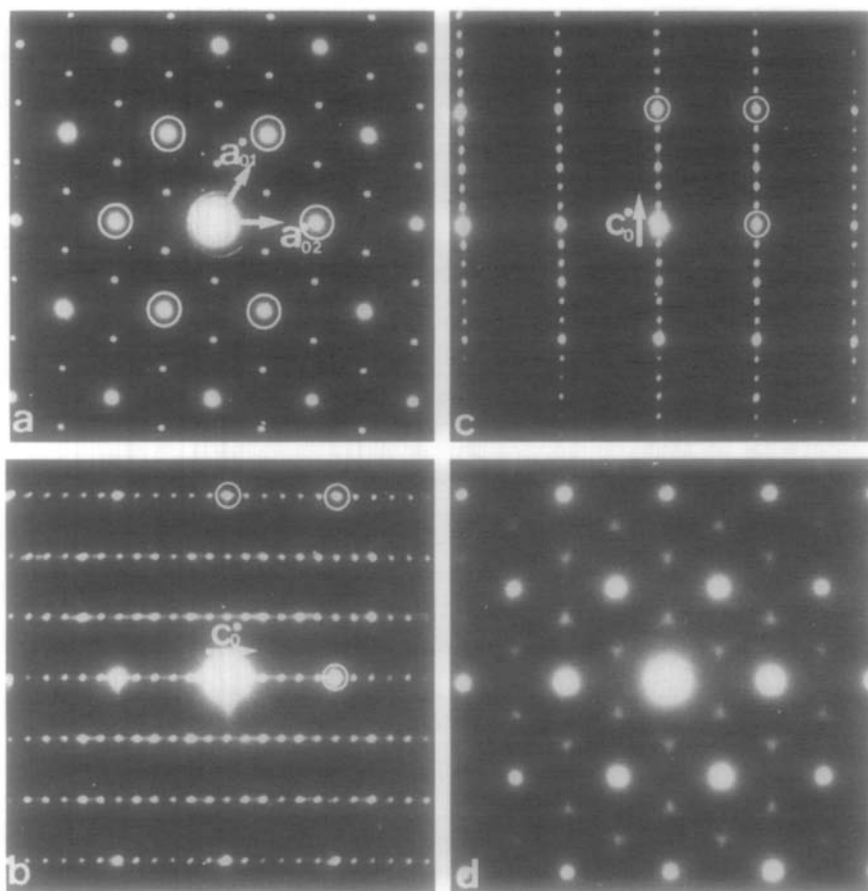

FIG. 8. Diffraction patterns of the γ -phase. (a) 0001^* section, (b) $10\bar{1}0^*$ section, (c) $11\bar{2}0^*$ section, (d) 0001^* section in the "transition state."

low 60° until -120°C . Transformation of the α' -phase occurs below the later temperature. This phase is also characterized by disordered sequence of the sheets along the

c -axis but with different β' -phase modulation on the basal plane.

In conclusion, it appears that on cooling the β -phase, two different paths are possible; they are represented schematically in Fig. 9. One of the paths refers to the thermodynamically stable form; it is schematically represented as $\beta \rightarrow \beta' \rightarrow \alpha$. The second refers to the frozen in metastable form; it can be represented as $\beta \rightarrow \beta' \rightarrow \alpha'$. A somewhat similar situation is known to exist in certain transition metal dichalcogenides (13, 14) and in lead orthovanadate (15).

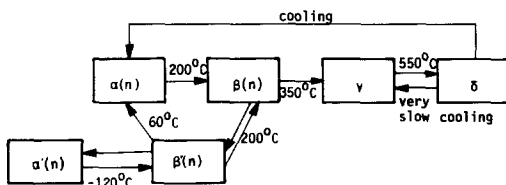

FIG. 9. Phase transition paths in In_2Se_3 .

References

1. J. VAN LANDUYT, G. VAN TENDELOO, AND S. AMELINCKX, *Phys. Status Solidi A* **30**, 299 (1975); **26**, K103 (1974); **26**, K99 (1974).
2. H. HAHN, *Angew. Chem.* **21**, 538 (1953).
3. S. A. SEMILETOV, *Sov. Phys. Crystallogr.* **6**, 158 (1961).
4. S. A. SEMILETOV, *Sov. Phys. Crystallogr.* **5**, 673 (1961).
5. K. OSAMURA, Y. MURAKAMI, AND Y. TOMIIE, *J. Phys. Soc. Japan* **21**, 1848 (1966).
6. A. LIKFORMAN, D. CARRÉ, AND R. HILLEL, *Acta Crystallogr. Sect. B* **34**, 1 (1978).
7. A. LIKFORMAN, P. H. FOURCROY, M. GUITTARD, J. FLAHAUT, R. POIRIER, AND N. SZYDLO, *J. Solid State Chem.* **33**, 91 (1980).
8. A. ANAGNOSTOPOULOS, C. MANOLIKAS, D. PAPA-DOPOULOS, AND J. SPYRIDELIS, *Phys. Status Solidi A* **72**, 731 (1982).
9. C. MANOLIKAS AND S. AMBELINKCX, *Phys. Status Solidi A* **60**, 607 (1980).
10. S. POPOVIC, B. CELUSTKA, AND D. BIDJIN, *Phys. Status Solidi A* **6**, 301 (1971).
11. A. RAM VERMA AND P. KRISHNA, "Polymorphism and Polytypism in Crystals," Wiley, New York (1966).
12. R. DE RIDDER, G. VAN TENDELOO, AND S. AMELINCKX, *Acta Crystallogr. Sect. A* **32**, 216 (1976).
13. J. VAN LANDUYT, G. VAN TENDELOO, AND S. AMELINCKX, *Phys. Status Solidi A* **26**, 359 (1974).
14. J. A. WILSON, F. J. DE SALVO, AND S. MAJAHAN, *Adv. Phys.* **24**, 117 (1975).
15. C. MANOLIKAS, G. VAN TENDELOO, AND S. AMELINCKX, *Mater. Res. Bull.* **22**, 193 (1987).