



ACTIVE CANCELLATION OF PRESSURE AT A POINT IN A PURE TONE DIFFRACTED DIFFUSE SOUND FIELD

J. GARCIA-BONITO, S. J. ELLIOTT AND M. BONILHA

*Institute of Sound and Vibration Research, University of Southampton,
Southampton SO17 1BJ, England*

(Received 15 May 1996, and in final form 22 August 1996)

In this paper the extension of the average zones of quiet produced in a diffuse acoustic field is studied when the acoustic pressure is cancelled at a point near a reflecting surface by using a remote secondary source. Analytical expressions for the extension of the zones of quiet generated when the cancellation point is close or on the surface of a rigid sphere, a wall, a two-wall edge and a corner have been derived. These theoretical results are compared with simulation results for the pressure in the vicinity of the cancellation point, and show good agreement.

© 1997 Academic Press Limited

1. INTRODUCTION

A system for the local active control of sound uses a secondary acoustic source to cancel the pressure at the location of an error microphone and thus generate a “zone of quiet” around this point. A local active control system with a closely spaced secondary source and error microphone was originally described by Olson and May [1]. In order to study the spatial matching between the primary and the secondary acoustic fields, which is the factor that determines the extent of the achievable zone of quiet, it can be assumed that the electrical control strategy adopted works perfectly at the frequency of interest. The pressure at the error microphone is thus completely cancelled by the control source and the interest centres on the effect of the superposed primary and secondary sound fields away from the point of cancellation.

Ross [2] performed computer simulations to calculate the effect of a point monopole secondary source used to cancel the acoustic pressure at another point due to a plane wave primary sound field. He found that, at low frequencies, the zone of quiet was a shell-like volume surrounding the secondary source, and that as the frequency increased the form and size of the zone of quiet degraded rapidly, being dependent on the relative orientation of the error microphone and the incident wave.

Joseph *et al.* [3, 4] have recently investigated the zone of quiet created when the total pressure is driven to zero at a field point on the axis of a piston source. By assuming a uniform pure tone sound field and a feedforward control arrangement, they found that the near field characteristics of the secondary source are very important in determining the resulting on-axis pressure distribution. David and Elliott [5] also performed computer simulations to estimate both the on-axis and off-axis extent of the near field zone of quiet created by a local active control system in which the secondary source is modelled as a piston in an infinite baffle. Both uniform and diffuse models of the primary pressure field

were used. They showed that the zone of quiet becomes larger as the control microphone is moved further away from the secondary source until, for large separations, the 10 dB zone of quiet, defined as that zone of the space in which the sound pressure level of the controlled acoustic field is at least 10 dB below that of the primary field, approaches the limiting case of a sphere of diameter one tenth of a wavelength; as predicted by Elliott *et al.* [6].

When the distance between the cancellation point and the secondary source is small compared with the acoustic wavelength, λ , the zone of quiet will be generated in the near field of the secondary source. Under these circumstances, the pressure due to the secondary source is predominantly governed by the directly radiated near field. The quiet zone formed in this region is thus relatively insensitive to the nature of the primary sound field. However, when the cancellation point is remote from the secondary source, the average zone of quiet becomes less dependent on the near field characteristics of the secondary source and more determined by the nature of the spatial correlation functions of both the primary and secondary acoustic fields. When the direct component of the secondary field near the cancellation point is negligible compared with the reverberant component in a diffuse field the space-averaged mean square pressure at a point Δr away from the point of cancellation, r_o , can be expressed as [6]

$$\frac{\langle |p(r_o + \Delta r)|^2 \rangle}{\langle |p_p|^2 \rangle + \langle |p_s|^2 \rangle} = 1 - \rho^2(\Delta r), \quad (1)$$

where $\rho(\Delta r)$ is the spatial cross-correlation function of the pressure and $\langle |p_p|^2 \rangle$ and $\langle |p_s|^2 \rangle$ are the space-averaged mean square pressure associated with the primary and secondary fields respectively. From equation (1) one can deduce that the 10 dB diffuse field zone of quiet converges to a sphere of about one tenth of a wavelength at the frequency of excitation [6]. This spherical shape of the zone of quiet is due to the isotropy of both primary and secondary acoustic fields which behave in the vicinity of the cancellation point as random acoustic fields with uniform energy distribution. In this case both primary and secondary acoustic fields exhibit a cross-correlation function for the pressure given by $\rho(\Delta r) = \text{sinc}(k\Delta r)$. If the cancellation point is near a diffracting or reflecting body, this expression is no longer a valid cross-correlation for any of the contributing acoustic fields. In this paper it will be shown that the problem of estimating the diffuse field zone of quiet created by a remote secondary source cancelling the acoustic pressure near a reflecting surface reduces to the calculation of the cross-correlation function of the primary and secondary fields in the vicinity of the cancellation point. Once this function is available, the space-averaged mean square pressure at a point Δr away from the point of cancellation can be expressed, after normalization, in a way similar to the result in equation (1).

The term “free” (or non-diffracted) diffuse sound field is used in this paper to refer to a reverberant acoustic field the statistical properties of which are spatially homogeneous and isotropic. When a diffracting body or reflecting surface is present the previous conditions are no longer satisfied and the term “diffracted” diffuse sound field is used instead. Thus, the expression “diffracted” diffuse field zone of quiet will be used here to denote a zone of quiet created near a reflecting surface (rigid sphere, wall, two-wall edge or corner) in a reverberant sound field, regardless of the spatial distribution of the surface. This use of the term “diffracted” includes any zone of quiet created in a region of a three-dimensional diffuse sound field in which the cross-correlation function of the pressure is not given by the $\text{sinc}(k\Delta r)$ function.

In Figure 1 are illustrated the four types of reflecting surfaces considered in this paper. Each surface has a particular spatial distribution of pressure associated with it in an otherwise diffuse sound field that dictates the level of pressure built up and the confine-

ment of acoustic energy at field points near the surface. Therefore, one can expect different cross-correlation functions of the acoustic pressure for each type of surface distribution.

In this paper it will be shown that as the confinement of acoustic energy produced by a reflecting surface increases, so the average zone of quiet created by cancelling the acoustic pressure at a point near such surface also increases. Analytical expressions for the average diffuse field zone of quiet after the cancellation of pressure at a point near a rigid sphere, a wall, a two-edge wall and a corner will be derived by using the same approach proposed in reference [6].

2. ACTIVE CANCELLATION OF PRESSURE AT A POINT NEAR A RIGID SPHERE IN A PURE TONE DIFFUSE SOUND FIELD

In this section an analytical expression is derived for the average zone of quiet created at a point in a primary diffuse acoustic field which is close to a rigid sphere. The secondary source is assumed to be several wavelengths away from the cancellation point. This implies that the secondary acoustic field contribution can also be properly modelled as a diffuse acoustic field, the pressure of which at the cancellation point can be adjusted in amplitude and phase so that the total pressure at the cancellation point is zero. One starts by assuming that the complex pressure at a point $r_o + \Delta r$, referred to a co-ordinate system with its origin at the centre of a sphere, due to a single source in a pure tone diffuse sound field can be considered as the sum of two components, one perfectly correlated and the other perfectly uncorrelated spatially with the pressure at r_o , i.e.,

$$p(r_o + \Delta r) = p_c(r_o + \Delta r) + p_u(r_o + \Delta r), \quad (2)$$

where $p_u(r_o + \Delta r)$ satisfies the condition

$$\langle p(r_o)p_u^*(r_o + \Delta r) \rangle = 0, \quad (3)$$

$\langle \rangle$ denotes the spatial average over the position of the sphere in a diffuse acoustic field and the asterisk denotes the complex conjugate. The pressure component $p_c(r_o + \Delta r)$ is related to $p(r_o)$ by a linear transformation which, in general, is a function of r_o and Δr . Therefore

$$p_c(r_o + \Delta r) = H(r_o, \Delta r)p(r_o). \quad (4)$$

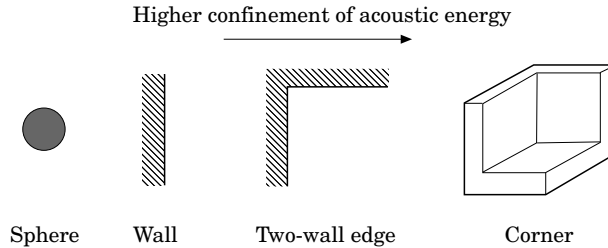

Figure 1. The reflecting surfaces considered to derive the cross-correlation of the acoustic pressure in a diffuse sound field near different types of reflecting surfaces.

In general, the function $H(r_o, \Delta r)$ is complex. The spatial average $\langle p(r_o)p^*(r_o + \Delta r) \rangle$ can be expressed, by using equations (2), (3) and (4), as

$$\langle p(r_o)p^*(r_o + \Delta r) \rangle = \langle |p(r_o)|^2 \rangle H(r_o, \Delta r), \quad (5)$$

and therefore

$$H(r_o, \Delta r) = \langle p(r_o)p^*(r_o + \Delta r) \rangle / \langle |p(r_o)|^2 \rangle, \quad (6)$$

which is equal to the spatial cross-correlation function $\rho(\Delta r)$ introduced above. Substituting equation (4) into equation (2), squaring and taking the spatial average gives the mean squared pressure at the point $r_o + \Delta r$, expressed as

$$\langle |p(r_o + \Delta r)|^2 \rangle = |H(r_o, \Delta r)|^2 \langle |p(r_o)|^2 \rangle + \langle |p_u(r_o + \Delta r)|^2 \rangle, \quad (7)$$

and therefore

$$\langle |p_u(r_o + \Delta r)|^2 \rangle = \langle |p(r_o + \Delta r)|^2 \rangle - |H(r_o, \Delta r)|^2 \langle |p(r_o)|^2 \rangle. \quad (8)$$

Now the pressure at $r_o + \Delta r$ is assumed to be due to two sources, a primary source and a secondary source, which individually generate the pressures $p_p(r_o + \Delta r)$ and $p_s(r_o + \Delta r)$ respectively, so that the total acoustic pressure at this location is

$$p(r_o + \Delta r) = p_p(r_o + \Delta r) + p_s(r_o + \Delta r). \quad (9)$$

Both acoustic fields satisfy equations (2), (4) and (8). Thus, for the primary acoustic field one has

$$p_p(r_o + \Delta r) = p_{pc}(r_o + \Delta r) + p_{pu}(r_o + \Delta r), \quad (10a)$$

$$p_{pc}(r_o + \Delta r) = p_p(r_o)H(r_o, \Delta r), \quad (10b)$$

$$\langle |p_{pu}(r_o + \Delta r)|^2 \rangle = \langle |p_p(r_o + \Delta r)|^2 \rangle - |H(r_o, \Delta r)|^2 \langle |p_p(r_o)|^2 \rangle, \quad (10c)$$

and, for the secondary acoustic field,

$$p_s(r_o + \Delta r) = p_{sc}(r_o + \Delta r) + p_{su}(r_o + \Delta r), \quad (11a)$$

$$p_{sc}(r_o + \Delta r) = p_s(r_o)H(r_o, \Delta r), \quad (11b)$$

$$\langle |p_{su}(r_o + \Delta r)|^2 \rangle = \langle |p_s(r_o + \Delta r)|^2 \rangle - |H(r_o, \Delta r)|^2 \langle |p_s(r_o)|^2 \rangle. \quad (11c)$$

Also, since both the primary and secondary sources are assumed to be several wavelengths apart, the following expression is true:

$$\langle p_{pu}(r_o + \Delta r)p_{su}^*(r_o + \Delta r) \rangle = 0. \quad (12)$$

If the secondary source is driven so that the pressure at r_o is zero, then

$$p_s(r_o) = -p_p(r_o), \quad (13)$$

and so [6]

$$p_{sc}(r_o + \Delta r) = -p_{pc}(r_o + \Delta r). \quad (14)$$

From equations (9), (10a), (10c), (11a) and (11c), the total space-averaged mean square pressure at a point Δr away from the point of cancellation is

$$\begin{aligned} \langle |p(r_o + \Delta r)|^2 \rangle &= \langle |p_p(r_o + \Delta r)|^2 \rangle - |H(r_o, \Delta r)|^2 \langle |p_p(r_o)|^2 \rangle \\ &\quad + \langle |p_s(r_o + \Delta r)|^2 \rangle - |H(r_o, \Delta r)|^2 \langle |p_s(r_o)|^2 \rangle, \end{aligned} \quad (15)$$

where $\langle |p_p(r_o)|^2 \rangle$ and $\langle |p_s(r_o)|^2 \rangle$ are the mean square pressures at r_o after control due to the primary and the secondary acoustic field respectively. If one assumes a similar average behaviour for the spatial variation of the mean square primary and secondary pressure fields and defines the function

$$G(r_o, \Delta r) = \langle |p_p(r_o + \Delta r)|^2 \rangle / \langle |p_p(r_o)|^2 \rangle = \langle |p_s(r_o + \Delta r)|^2 \rangle / \langle |p_s(r_o)|^2 \rangle, \quad (16)$$

then equation (15) becomes

$$\langle |p(r_o + \Delta r)|^2 \rangle = (\langle |p_p(r_o)|^2 \rangle + \langle |p_s(r_o)|^2 \rangle)(G(r_o, \Delta r) - |H(r_o, \Delta r)|^2), \quad (17)$$

and therefore

$$\frac{\langle |p(r_o + \Delta r)|^2 \rangle}{\langle |p_p(r_o)|^2 \rangle + \langle |p_s(r_o)|^2 \rangle} = G(r_o, \Delta r) - |H(r_o, \Delta r)|^2. \quad (18)$$

This equation can be normalized with respect to the sum of the mean squared pressures of the primary and secondary acoustic fields, after control, well away from the diffracting sphere. Since both the primary and secondary acoustic fields are diffuse, the diffraction pattern produced by a rigid sphere on each of them must be the same. Thus, if one defines the function

$$D(r_o) = \langle |p_p(r_o)|^2 \rangle / \langle |p_{pf}|^2 \rangle = \langle |p_s(r_o)|^2 \rangle / \langle |p_{sf}|^2 \rangle, \quad (19)$$

with $\langle |p_{pf}|^2 \rangle$ and $\langle |p_{sf}|^2 \rangle$ denoting the mean squared pressures associated with the primary and secondary fields at a point several wavelengths from the diffracting sphere, respectively, then equation (18) can be normalized to give

$$\frac{\langle |p(r_o + \Delta r)|^2 \rangle}{\langle |p_{pf}|^2 \rangle + \langle |p_{sf}|^2 \rangle} = D(r_o)(G(r_o, \Delta r) - |H(r_o, \Delta r)|^2). \quad (20)$$

In the case previously considered with no diffracting sphere present $D(r_o) = 1$, $G(r_o, \Delta r) = 1$, $H(r_o, \Delta r) = \rho(\Delta r)$ and equation (20) reduces to equation (1): i.e.,

$$\frac{\langle |p(r_o + \Delta r)|^2 \rangle}{\langle |p_p|^2 \rangle + \langle |p_s|^2 \rangle} = 1 - |H(r_o, \Delta r)|^2 = 1 - \rho^2(\Delta r), \quad (21)$$

which coincides with the expression found by Elliott *et al.* [6] for the average zone of quiet after cancellation of pressure at a point in a pure tone diffuse sound field not affected by diffraction.

According to the results derived in Appendix 1, the expressions for the functions $D(r_o)$, $G(r_o, \Delta r)$ and $H(r_o, \Delta r)$ when the cancellation point is near a rigid sphere of radius a are

$$D(r_o) = \sum_{m=0}^{\infty} (2m+1)[C'_m(kr_o)]^2, \quad (22)$$

$$G(r_o, \Delta r) = \frac{\sum_{m=0}^{\infty} (2m+1)[C'_m(k(r_o + \Delta r))]^2}{\sum_{m=0}^{\infty} (2m+1)[C'_m(kr_o)]^2}, \quad (23)$$

$$H(r_o, \Delta r) = \frac{\sum_{m=0}^{\infty} (2m+1)C'_m(kr_o)C_m'^*(k(r_o + \Delta r))}{\sum_{m=0}^{\infty} (2m+1)[C'_m(kr_o)]^2}, \quad (24)$$

with

$$C'_m(kr) = (j^m)[\cos \delta_{ms}j_m(kr) + \sin \delta_{ms}n_m(kr)], \quad \delta_{ms} = \tan^{-1}\left(-\frac{j'_m(ka)}{n'_m(ka)}\right), \quad (25)$$

where k is the wavenumber, $j_m(kr)$ is the spherical Bessel function of order m , $n_m(kr)$ is the spherical Neumann function of order m , j'_m and n'_m are the first derivatives of j_m and n_m , respectively, and $j = \sqrt{-1}$. From equations (22), (23) and (24) one concludes that expression (20) is a real function that defines the far field average zone of quiet after pressure cancellation at a point near or on the surface of a rigid sphere. It is important to point out that equation (20) is a generalization of equation (1).

In order to estimate the extent of the diffuse field zone of quiet when the pressure at a point near or on the surface of a rigid sphere of radius a is cancelled by a remote secondary source, a model of a diffracted diffuse field has been developed by adding up the contribution of 72 plane waves coming from all possible directions, each one scattered by the sphere. By taking the analytical solution for the scattering of a plane wave by a rigid sphere [7] and referring it to a suitable co-ordinate system, the orientation of which is defined by the direction of the incoming plane, it can be shown that the complex pressure at a field point lying on the x - y plane can be expressed as [8]

$$p_p(x, y) = \sum_{K=1}^{K_{max}} \sum_{L=1}^{L_{max}} (a_{KL} + jb_{KL}) \sin(\theta_K) \left[\sum_{m=0}^{\infty} (-j)^{m+1} (2m+1) \right. \\ \left. \times P_m(\cos \theta) \frac{j_m(kr)n'_m(ka) - n_m(kr)j'_m(ka)}{j'_m(ka) - jn'_m(ka)} \right], \quad (26)$$

where

$$r = \sqrt{x^2 + y^2}, \quad \theta = \cos^{-1}(\mathbf{r}_u \cdot \mathbf{v}_u). \quad (27)$$

In equation (26), a_{KL} and b_{KL} are real numbers chosen from a random population with a Gaussian distribution $N(0, 1)$ and the multiplicative factor $\sin(\theta_K)$ is included to ensure that, on average, the energy associated with the incident waves is uniform from all directions. $P_m(\cos \theta)$ is the Legendre polynomial of order m and the other terms have been defined in equation (25). Equation (26) gives the complex pressure in the x - y plane due to a combination of L_{max} plane waves in the azimuthal direction for each of the K_{max} polar directions. The values of K_{max} and L_{max} used in equation (26) for the simulations reported here are 6 and 12 respectively.

In equation (27), \mathbf{r}_u is the unit vector pointing in the direction of the field point considered and \mathbf{v}_u is the unit vector in the direction of propagation of the incoming wave. In Figure 2 is shown the average diffuse field zone of quiet for a sphere with $ka = 1.5$, i.e., with radius $a \simeq 0.24\lambda$, when the acoustic pressure is cancelled at a point located on the surface of the sphere and at a distance of 0.4λ from its centre respectively (corresponding to 0.16λ from the surface of the sphere). The solid line is calculated from equation (20) and the dashed line is the average zone of quiet for 50 samples of individually calculated controlled fields. Each individual sample of the controlled field was calculated

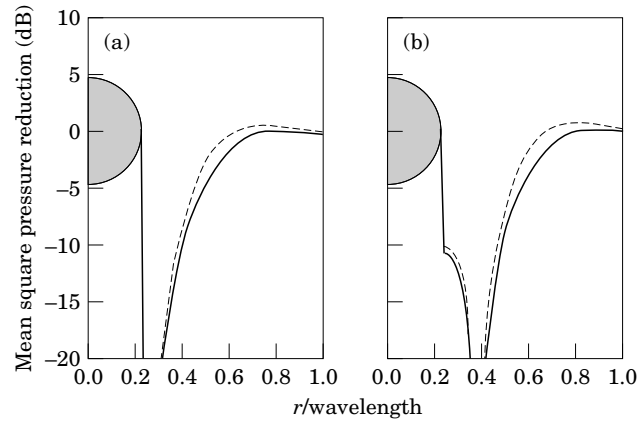

Figure 2. The average radial extent of the zone of quiet after pressure cancellation at a point on the surface of a rigid sphere (a), and at a distance of 0.4λ from its centre (b). The solid line represents equation (20) and the dashed line is the result of averaging over 50 samples of controlled diffuse acoustic fields using the model defined by equation (26). The figures correspond to $ka = 1.5$.

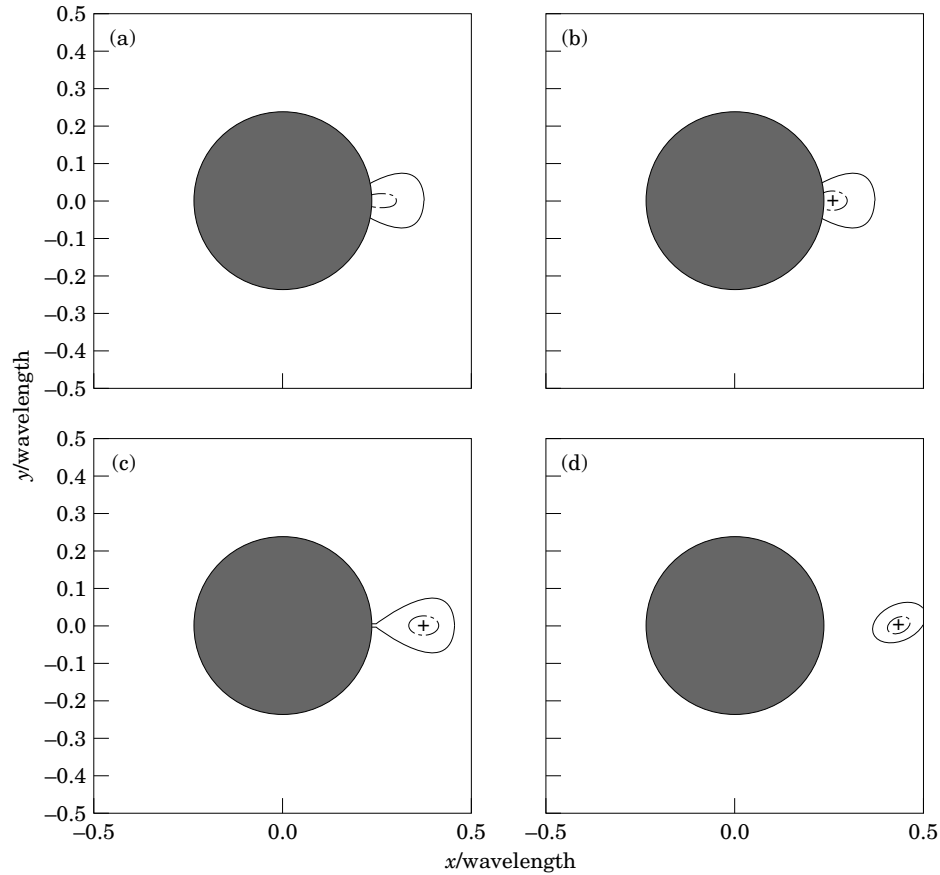

Figure 3. The simulated contours of the regions within which the space-averaged mean square pressure is reduced by 10 dB (solid line) and 20 dB (dashed line) due to the cancellation of the acoustic pressure at a field point located at a distance d from the surface of a rigid sphere, for $ka = 1.5$. The contour plots correspond to positions of the cancellation point (as shown by the point $+$) equal to $d =$ (a) 0, (b) 0.05λ , (c) 0.15λ and (d) 0.2λ , and were obtained from an ensemble of 50 samples of controlled diffuse acoustic fields by using the model defined by equation (26).

by superposing two samples of diffracted diffuse field near a sphere generated with equation (26), so that the total pressure at the cancellation point was zero. A good agreement can be observed between the theoretical and averaged results.

In Figure 3 are shown the average diffuse field zones of quiet averaged over 50 samples of controlled fields generated by superposing a primary and a secondary diffracted diffuse field, both calculated using equation (26), so that the acoustic pressure is cancelled at a point on the surface of the sphere and at positions 0.05λ , 0.15λ and 0.2λ from the surface respectively. The value of ka has been chosen equal to 1.5. From Figure 3, one observes that the cancellation of the acoustic pressure at a point on or very near a rigid sphere tends to produce a larger zone of quiet in the direction perpendicular to the surface (radial direction) than if the sphere was not present. This suggests that if the cancellation point is close enough to the surface, the generated zone of quiet will be attached to the surface and the radial length of the zone of quiet will tend to be longer than that produced by the cancellation of the acoustic pressure some distance away from the reflecting sphere.

3. ACTIVE CANCELLATION OF PRESSURE AT A POINT NEAR A RIGID WALL IN A PURE TONE DIFFUSE SOUND FIELD

In this section an analytical expression is derived for the average zone of quiet created after pressure cancellation at a point in a primary diffuse acoustic field which is close to a reflecting wall. By using the same approach as in section 2, it can be shown that the average diffuse field zone of quiet after pressure cancellation at a field point at a distance x_o from an infinite rigid wall can also be expressed as

$$\frac{\langle |p(x_o + \Delta x)|^2 \rangle}{\langle |p_p|^2 \rangle + \langle |p_s|^2 \rangle} = D(x_o)[G(x_o, \Delta x) - |H(x_o, \Delta x)|^2], \quad (28)$$

where

$$D(x_o) = \langle |p_p(x_o)|^2 \rangle / \langle |p_p|^2 \rangle = \langle |p_s(x_o)|^2 \rangle / \langle |p_s|^2 \rangle, \quad (29)$$

$$G(x_o, \Delta x) = \langle |p_p(x_o + \Delta x)|^2 \rangle / \langle |p_p(x_o)|^2 \rangle = \langle |p_s(x_o + \Delta x)|^2 \rangle / \langle |p_s(x_o)|^2 \rangle, \quad (30)$$

$$H(x_o, \Delta x) = \langle p(x_o)p^*(x_o + \Delta x) \rangle / \langle |p(x_o)|^2 \rangle. \quad (31)$$

The expressions for the functions $D(x_o)$, $G(x_o, \Delta x)$ and $H(x_o, \Delta x)$ in this case, are derived in Appendix 2 for Δx in the direction normal to the wall, and are

$$D(x_o) = 1 + \text{sinc}(2kx_o), \quad (32)$$

$$G(x_o, \Delta x) = \{1 + \text{sinc}(2k(x_o + \Delta x))\} / \{1 + \text{sinc}(2kx_o)\}, \quad (33)$$

$$H(x_o, \Delta x) = \{\text{sinc}(k\Delta x) + \text{sinc}(k(2x_o + \Delta x))\} / \{1 + \text{sinc}(2kx_o)\}. \quad (34)$$

If the cancellation point is on the wall, then $x_o = 0$ and equation (28) becomes

$$\frac{\langle |p(\Delta x)|^2 \rangle}{\langle |p_p|^2 \rangle + \langle |p_s|^2 \rangle} = \frac{1 - \text{sinc}^2(2k\Delta x)}{2}. \quad (35)$$

On the other hand, if the cancellation point is distant enough from the wall, i.e., $x_o \rightarrow \infty$, then equation (28) converges to

$$\frac{\langle |p(x_o + \Delta x)|^2 \rangle}{\langle |p_p|^2 \rangle + \langle |p_s|^2 \rangle} = 1 - \text{sinc}^2(k\Delta x), \quad (36)$$

which, as expected, coincides with the result derived by Elliott *et al.* [6] for the cancellation

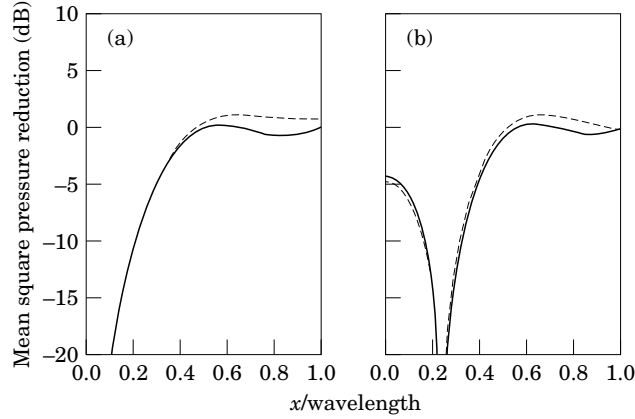

Figure 4. The average extent of the zone of quiet in the direction normal to a rigid wall after cancellation of the acoustic pressure at a point on the surface of the wall (a), and at a distance of 0.25λ from it (b). The solid line represents equation (28) and the dashed line is the result of averaging 50 samples of controlled diffuse acoustic fields by using the model defined by equation (37).

of pressure at a point in a free (non-diffracted) diffuse sound field by a remote secondary source.

In Figure 4 is shown, by the solid line, the average diffuse field zone of quiet when the acoustic pressure is cancelled at a point located on the surface of a rigid wall and at a distance of 0.25λ from it, respectively, calculated with equation (28). Also, the dashed line shows the zone of quiet averaged over 50 samples of individually controlled fields which is in good agreement with the analytical results. Each sample of controlled field was calculated by superposing two samples of diffracted diffuse field near a rigid wall generated with the following model [9]

$$p(x, z) = \sum_{K=1}^{K_{max}} \sum_{L=1}^{L_{max}} (a_{KL} + jb_{KL}) \sin \theta_K [\exp(-jk(-z \sin \theta_K \cos \phi_L - x \cos \theta_K) + \exp(-jk(z \sin \theta_K \cos \phi_L + x \cos \theta_K))]. \quad (37)$$

The co-ordinate system used in equation (37) is depicted in Figure 5. The first exponential term in the sum of equation (37) is the phase shift associated with an incident plane wave and the second represents the phase shift of the corresponding reflected wave. The meanings of the different terms in equation (37) are as in equation (26) and it gives the pressure in the x - z plane due to a combination of L_{max} plane waves in the azimuthal

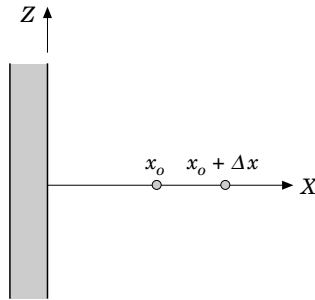

Figure 5. The co-ordinate system used in equation (37). x_0 denotes the position of the cancellation point.

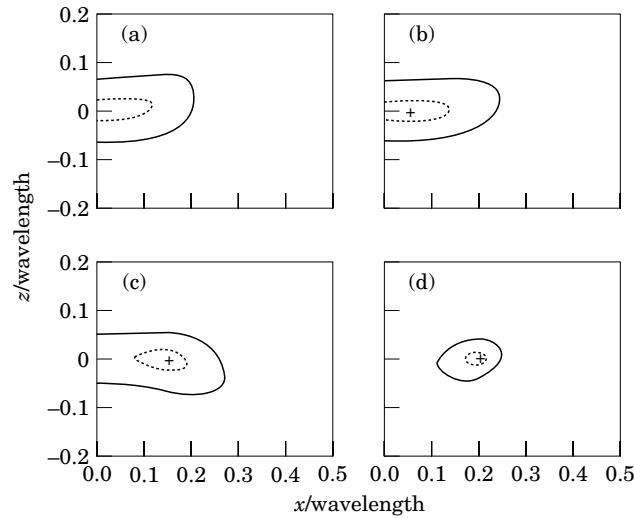

Figure 6. The simulated contours of the regions within which the space-averaged mean square pressure is reduced by 10 dB (solid line) and 20 dB (dashed line) due to the cancellation of the acoustic pressure at a point located at a distance x_o from the surface of a rigid wall. The contour plots correspond to positions of the cancellation point (as shown by the point +) equal to $x_o =$ (a) 0, (b) 0.05λ , (c) 0.15λ and (d) 0.2λ , and were obtained from an ensemble of 50 samples of controlled diffuse acoustic fields by using the model defined by equation (37).

direction for each of the K_{max} polar directions. The values of K_{max} and L_{max} used in equation (37) for the simulations showed in Figure 4 are both 12.

In Figure 6 are shown the average diffuse field zones of quiet in the x - z plane averaged over 50 samples of controlled fields generated by superposing a primary and a secondary diffracted diffuse field, both calculated by using equation (37), so that the acoustic pressure is cancelled at a point on the surface of the wall and at positions $x_o = 0.05\lambda$, 0.15λ and 0.2λ from the surface. These results show that the cancellation of the acoustic pressure at a point on or near a rigid wall produces a larger zone of quiet in the direction perpendicular to the surface (normal direction) than if the wall were not present. If the cancellation point is close enough to the surface, the generated zone of quiet will thus be attached to the surface and the length of the zone of quiet in the normal direction will tend to be longer than that produced by the cancellation of the acoustic pressure some distance away from the reflecting wall. This is because, as well as the pressure being zero on the wall, the normal pressure gradient is also zero due to the zero velocity condition. This suggests that when the acoustic pressure is cancelled at a point located on the surface of the wall, i.e., $x_o = 0$, the generated zone of quiet is very similar to half the zone of quiet obtained after the cancellation of pressure and pressure gradient at a point in a non-diffracted diffuse field (a “free” diffuse field) [10]. The effect of cancelling pressure and pressure gradient is similar to that of cancelling the pressure at two closely spaced microphones; as shown, for example, in the experimental results presented by Miyoshi and Kaneda [11], although these authors plotted contours of 6 dB and 14.4 dB attenuation in their zones of quiet.

In Figures 4 and 6 it is shown that if the cancellation point is near a rigid wall, the zone of quiet tends to “attach” to its surface, helping to increase the extension of the quiet zone. This also agrees with what it was found in section 2 for the case in which the diffracting body is a sphere.

4. ACTIVE CANCELLATION OF PRESSURE AT A POINT NEAR A TWO-WALL EDGE IN A PURE TONE DIFFUSE SOUND FIELD

In this section an analytical expression is derived for the average zone of quiet created in a primary diffuse acoustic field close to a two-wall edge. By following the same approach presented in sections 2 and 3, it can be shown that the average diffuse field zone of quiet after the cancellation of pressure at a point near a two-wall edge and lying on the line of symmetry defined by the relationship $y = z = r/\sqrt{2}$, is given by

$$\frac{\langle |p(r_o + \Delta r)|^2 \rangle}{\langle |p_p|^2 \rangle + \langle |p_s|^2 \rangle} = D(r_o)[G(r_o, \Delta r) - |H(r_o, \Delta r)|^2]. \quad (38)$$

According to the results derived in Appendix 3, the corresponding expressions for the functions D , G and H are

$$D(r_o) = 1 + 2 \operatorname{sinc}(\sqrt{2}kr_o) + \operatorname{sinc}(2kr_o), \quad (39)$$

$$G(r_o, \Delta r) = \frac{1 + 2 \operatorname{sinc}(\sqrt{2}k(r_o + \Delta r)) + \operatorname{sinc}(2k(r_o + \Delta r))}{1 + 2 \operatorname{sinc}(\sqrt{2}kr_o) + \operatorname{sinc}(2kr_o)}, \quad (40)$$

$$H(r_o, \Delta r) = \frac{\operatorname{sinc}(k\Delta r) + 2 \operatorname{sinc}(k\sqrt{(\Delta r)^2 + (2r_o + \Delta r)^2}/\sqrt{2}) + \operatorname{sinc}(k(2r_o + \Delta r))}{1 + 2(\operatorname{sinc}(\sqrt{2}kr_o) + \operatorname{sinc}(2kr_o))}. \quad (41)$$

In Figure 7 is shown (by the solid line) the average diffuse field zone of quiet for cancellation of pressure at a point lying on the line of symmetry of a two-wall edge located at $r_o = 0$ and $r_o = 0.25\lambda$, respectively, calculated with equation (38). Shown in the same figure (by the dashed line) is the zone of quiet averaged over 50 samples of controlled fields. These results show a good agreement with the analytical results from equation (38). Each sample of controlled field was calculated by superposing two samples of diffracted

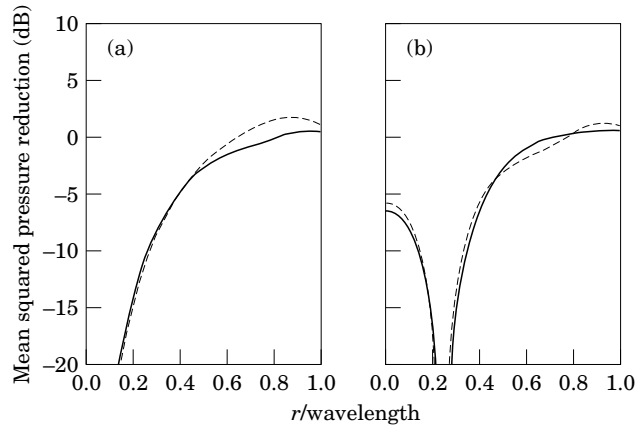

Figure 7. The average extent of the zone of quiet along the line of symmetry, $y = z = r/\sqrt{2}$, of a two-wall edge after cancellation of the acoustic pressure at a point $r_o = 0$ (a), and $r_o = 0.25\lambda$ (b). The solid line is the analytical solution from equation (38) and the dashed line is the result of averaging over 50 samples of controlled diffuse acoustic field by using the model defined by equation (42).

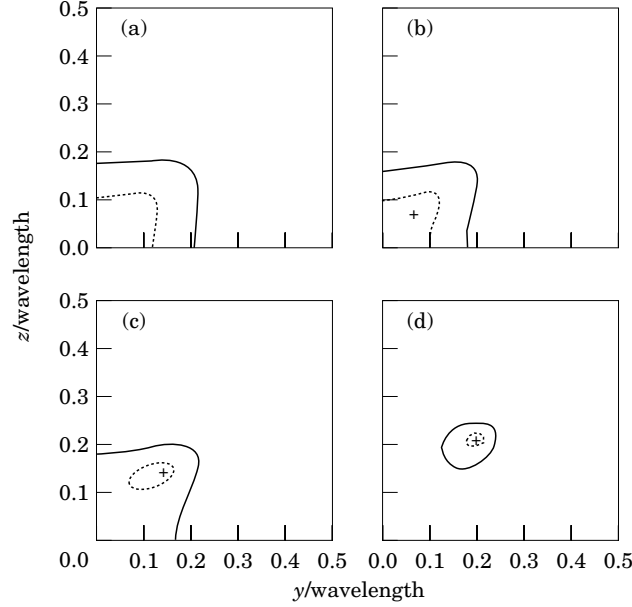

Figure 8. The simulated contours of the regions within which the space-averaged mean square pressure is reduced by 10 dB (solid line) and 20 dB (dashed line) due to the cancellation of the acoustic pressure at a point on the line of symmetry of a two-wall edge at a distance r_o from the intersection of the two walls. The contour plots correspond to positions of the cancellation point (as shown by the point +) equal to $r_o =$ (a) 0, (b) 0.1λ , (c) 0.2λ and (d) 0.3λ , and were obtained from an ensemble of 50 samples of controlled diffuse acoustic fields by using the model defined by equation (42).

diffuse field calculated along the line of symmetry of a two-wall edge generated with the model [9]

$$p(r) = \sum_{K=1}^{K_{max}} \sum_{L=1}^{L_{max}} (a_{KL} + jb_{KL}) \sin \theta_K [\exp(-jk(b+c)) + \exp(-jk(-b+c)) + \exp(-jk(b-c)) + \exp(-jk(-b-c))], \quad (42)$$

where

$$b = r \sin \theta_K \cos \phi_L / \sqrt{2}, \quad c = r \sin \theta_K \sin \phi_L / \sqrt{2}. \quad (43)$$

This equation gives the pressure at a field point on the line of symmetry of a two-wall edge at a distance r from the edge due to the combination of L_{max} plane waves in the azimuthal direction for each of the K_{max} polar directions. For the simulations shown in Figure 7 by the dashed line, the values of K_{max} and L_{max} in equation (42) are 18 and 9 respectively, which were suitable values to speed up the convergence of the average zone of quiet.

In Figure 8 is shown the average diffuse field zone of quiet in the $x-z$ plane near a two-wall edge, averaged over 50 samples of controlled fields, generated by superposing a primary and a secondary diffracted diffuse field, both calculated with equation (42), so that the acoustic pressure is cancelled at a point on the edge and at positions in the line of symmetry at $r_o = 0.1\lambda$, 0.2λ and 0.3λ from the edge. As for the case of the sphere and the wall, the resultant zone of quiet tends to attach to the rigid walls for positions of the cancellation point close to the edge. When the cancellation point is at a distance greater

than about 0.3λ from the edge, however, the zone of quiet is almost unaffected by the diffracting surface.

5. ACTIVE CANCELLATION OF PRESSURE AT A POINT NEAR A CORNER IN A PURE TONE DIFFUSE SOUND FIELD

In this section an analytical expression is derived for the average zone of quiet created at a point in a primary diffuse acoustic field close to a corner, as shown in Figure 9. By following the same approach presented in the previous sections, it can be shown that the average diffuse field zone of quiet after cancelling the pressure at a field near a corner defined by three rigid walls is given by equation (38). According to the results derived in Appendix 3, the expressions for the functions $D(r_o)$, $G(r_o, \Delta r)$ and $H(r_o, \Delta r)$ for a field point lying on the line of symmetry defined by the condition $x = y = z = r/\sqrt{3}$ (see Figure 9) are

$$D(r_o) = 1 + 3 \operatorname{sinc}(2kr_o/\sqrt{3}) + 3 \operatorname{sinc}(2\sqrt{2/3}kr_o) + \operatorname{sinc}(2kr_o), \quad (44)$$

$$G(r_o, \Delta r) = \frac{1 + 3 \operatorname{sinc}(2k(r_o + \Delta r)/\sqrt{3}) + 3 \operatorname{sinc}(2\sqrt{2/3}k(r_o + \Delta r)) + \operatorname{sinc}(2k(r_o + \Delta r))}{1 + 3 \operatorname{sinc}(2kr_o/\sqrt{3}) + 3 \operatorname{sinc}(2\sqrt{2/3}kr_o) + \operatorname{sinc}(2kr_o)}, \quad (45)$$

and

$$\begin{aligned} H(r_o, \Delta r) = & [\operatorname{sinc}(k\Delta r) + 3 \operatorname{sinc}(k\sqrt{2(\Delta r)^2 + (2r_o + \Delta r)^2}/\sqrt{3}) \\ & + 3 \operatorname{sinc}(k\sqrt{(\Delta r)^2 + 2(2r_o + \Delta r)^2}/\sqrt{3}) + \operatorname{sinc}(k(2r_o + \Delta r))] \\ & / [1 + 3 \operatorname{sinc}(2kr_o/\sqrt{3}) + 3 \operatorname{sinc}(2\sqrt{2/3}kr_o) + \operatorname{sinc}(2kr_o)]. \end{aligned} \quad (46)$$

In Figure 10 is shown, by the solid line, the average diffuse field zone of quiet along the line of symmetry of a corner (see Figure 9) when the acoustic pressure is cancelled at a point located at $r_o = 0$ and $r_o = 0.25\lambda$ respectively, calculated by using equation (38). Also, by the dashed line is depicted the zone of quiet averaged over 50 samples of controlled fields, which shows good agreement with the analytical results. Each sample of controlled

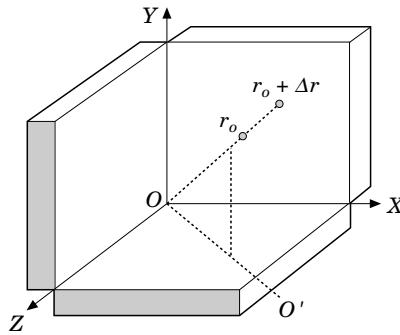

Figure 9. The co-ordinate system used to derive the average diffuse field zone of quiet near a corner.

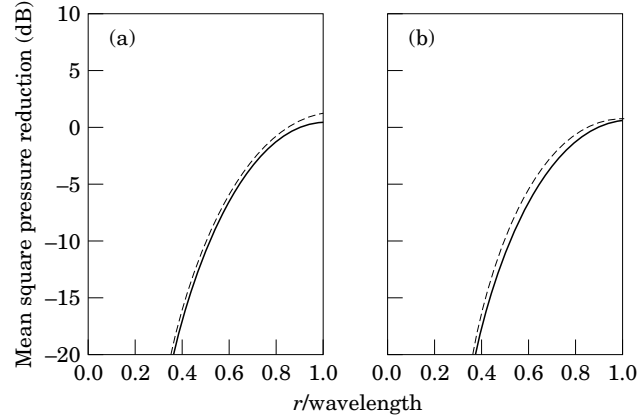

Figure 10. The average extent of the zone of quiet along the line of symmetry, defined by $x = y = z = r/\sqrt{3}$ in a corner after cancellation of the acoustic pressure at $r_o = 0$ (a), and $r_o = 0.25\lambda$ (b). (See Figure 7.) The solid line represents equation (38) and the dashed line is the result of averaging over 50 samples of controlled diffuse acoustic fields by using the model defined by equation (47).

field was calculated by superposing two samples of diffracted diffuse field calculated along the line of symmetry of a corner generated with the model [9]

$$\begin{aligned}
 p(r) = & \sum_{K=1}^{K_{max}} \sum_{L=1}^{L_{max}} (a_{KL} + jb_{KL}) \sin \theta_K [\exp(-jk(a+b+c)) \\
 & + \exp(-jk(-a+b+c)) + \exp(-jk(a-b+c)) + \exp(-jk(a+b-c)) \\
 & + \exp(-jk(a-b-c)) + \exp(-jk(-a-b+c)) + \exp(-jk(-a+b-c)) \\
 & + \exp(-jk(-a-b-c))], \quad (47)
 \end{aligned}$$

where

$$a = r \cos \theta_K / \sqrt{3}, \quad b = r \sin \theta_K \cos \phi_L / \sqrt{3}, \quad c = r \sin \theta_K \sin \phi_L / \sqrt{3}. \quad (48)$$

Equation (47) gives the pressure at a field point on the line of symmetry of a corner and at a distance r from it due to a combination of L_{max} plane waves in the azimuthal direction for each of the polar directions. For the simulations shown in Figure 10 in dashed line, the values of K_{max} and L_{max} used in equation (47) were both equal to 18. This value was chosen in order to generate samples of a diffuse acoustic field which gave a rapid convergence of the averaged zone of quiet.

In Figure 11 is shown the average diffuse field zone of quiet near a corner in the $y-o'$ plane (see Figure 9) averaged over 50 samples of controlled fields generated by superposing a primary and a secondary diffracted field both calculated with equation (47), so that the acoustic pressure is cancelled at positions in the line of symmetry at $r_o = 0, 0.1\lambda, 0.3\lambda$ and 0.4λ from the intersection of the three walls.

6. DISCUSSION AND CONCLUSIONS

The effect of a rigid reflector on the zone of quiet generated by an active control system depends on the extension and shape of the reflecting body. If one considers any diffracting or reflecting body as an element which increases the number of waves with correlated phase which contribute to the total pressure at a given field point, then the effect of such a body

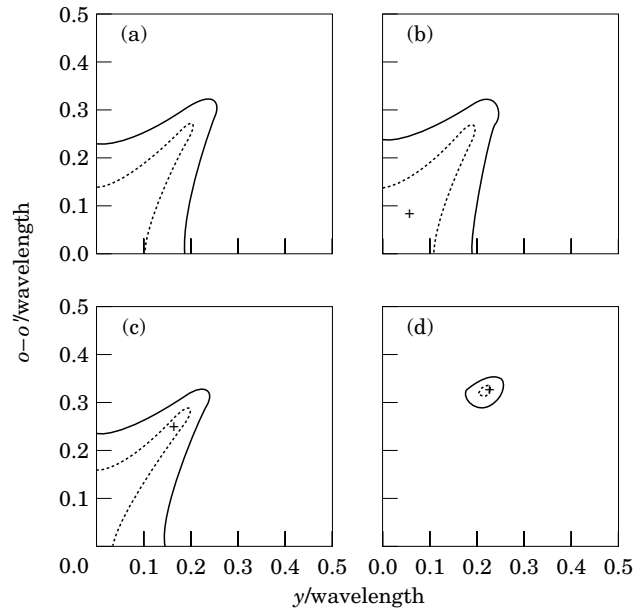

Figure 11. The simulated contours of the regions within which the space average mean square pressure is reduced by 10 dB (solid line) and 20 dB (dashed line) due to the cancellation of the acoustic pressure at a point on the line of symmetry of a corner at a distance r_o from the intersection of the three walls. The contour plots correspond to the positions of the cancellation point (as shown by the point +) equal to $r_o =$ (a) 0, (b) 0.10λ , (c) 0.3λ and (d) 0.4λ , and were obtained from an ensemble of 50 samples of controlled diffuse acoustic fields by using equation (47).

can be understood in terms of an increase in the value of the spatial pressure cross-correlation function with respect to the free diffuse field. In Figure 12 are compared the theoretical average diffuse field zone of quiet created by a remote secondary source cancelling the acoustic pressure at a point near a rigid sphere (b), a wall (c), a two-wall

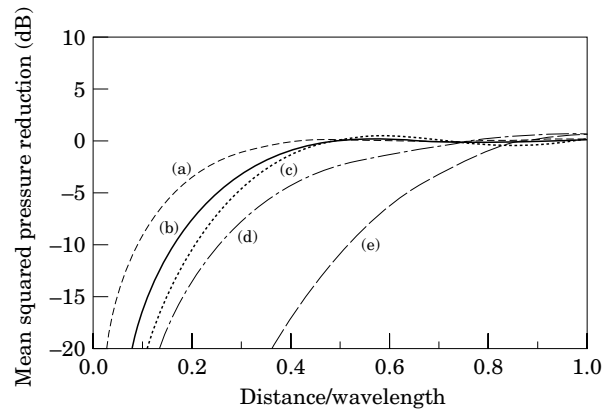

Figure 12. A comparison of the average extent of the diffuse field zone of quiet created by a remote secondary source after cancellation of pressure at a point located on the surface of a rigid sphere for $ka = 1.5$ (b), and on a wall (c). Curve (d) represents the zone of quiet along the line of symmetry of a two-wall edge when the cancellation point is at the edge and curve (e) represents the zone of quiet along the line of symmetry of a corner when the cancellation point is at the corner. Curve (a) represents the zone of quiet after pressure cancellation at a point in a free diffuse field (without diffraction), after Elliott *et al.* [6].

TABLE 1

The average spatial “extent” of the 10 dB zone of quiet in a diffuse acoustic field after cancelling the pressure at a point close to different types of reflecting surfaces by using a remote secondary source

Type of reflecting body	Curve	“Extent” of 10 dB quiet zone	Cancellation point
None	(a)	0.1λ	Anywhere
Sphere ($ka = 1.5$)	(b)	0.17λ	On the surface
Wall	(c)	0.20λ	On the surface
Two-wall edge	(d)	0.25λ	On the edge
Corner	(e)	0.5λ	At the corner

edge (d) and a corner (e). The case of pressure cancellation at a point in a diffuse sound field with no diffraction [6], (a), is also depicted for comparison.

From these results one can conclude that as the reflecting surface restricts the possible directions of random contributions, the generated zone of quiet broadens. In Table 1 the “extent” of the 10 dB average diffuse field zone of quiet is defined, as measured along the corresponding line of symmetry associated with each type of reflecting surface considered in Figure 1, after cancellation of pressure at a point on the surface. One can observe that the “extent” of the zone of quiet when the diffuse field is diffracted by a sphere is a function of ka . For very small values of ka the sphere is very small compared with a wavelength and, therefore, its effect on the acoustic field is negligible. In this case the curve (b) converges to curve (a) in Figure 12: i.e., the zone of quiet coincides with that obtained in a free diffuse sound field. If, on the other hand, ka is very high, the sphere behaves acoustically like a wall and thus, curve (b) converges to curve (c).

ACKNOWLEDGMENTS

This work was partially supported by the “La Caixa” Foundation and CIRIT (Generalitat de Catalunya) in Barcelona, Spain.

REFERENCES

1. H. F. OLSON and E. G. MAY 1953 *Journal of the Acoustical Society of America* **25**, 1130–1136. Electronic sound absorber.
2. C. F. ROSS 1980 *Ph.D. Thesis, University of Cambridge*. Active control of sound.
3. P. JOSEPH, S. J. ELLIOTT and P. A. NELSON 1994 *Journal of Sound and Vibration* **172**, 605–627. Near field zones of quiet.
4. P. F. JOSEPH 1990 *Ph.D. Thesis, University of Southampton*.
5. A. DAVID and S. J. ELLIOTT 1994 *Applied Acoustics* **41**, 63–79. Numerical studies of actively generated quiet zones.
6. S. J. ELLIOTT, P. JOSEPH, A. J. BULLMORE and P. A. NELSON 1988 *Journal of Sound and Vibration* **120**, 183–189. Active cancellation at a point in a pure tone diffuse sound field.
7. P. M. MORSE 1948 *Vibration and Sound*. New York: McGraw-Hill.
8. J. GARCIA-BONITO and S. J. ELLIOTT 1993 *University of Southampton, I.S.V.R. Technical Memorandum no. 728*. Numerical simulations of local active control in diffracted diffuse sound fields.
9. R. V. WATERHOUSE 1955 *Journal of the Acoustical Society of America* **27**, 247–258. Interference patterns in reverberant sound fields.
10. S. J. ELLIOTT and J. GARCIA-BONITO 1995 *Journal of Sound and Vibration* **186**, 696–704. Active cancellation of pressure and pressure gradient in a diffuse sound field.

11. M. MIYOSHI and Y. KANEDA 1991 *Noise Control Engineering Journal* **36**, 85–90. Active control of broadband random noise in a reverberant three-dimensional space.
12. R. V. WATERHOUSE 1963 *Journal of the Acoustical Society of America* **35**, 1610–1620. Diffraction effects in a random sound field.
13. R. V. WATERHOUSE 1984 *Journal of the Acoustical Society of America* **75**, 695–706. Near field diffraction patterns at a sphere or cylinder.
14. R. V. WATERHOUSE and R. K. COOK 1965 *Journal of the Acoustical Society of America* **37**, 424–428. Interference patterns in reverberant sound fields II.

APPENDIX 1: DIFFUSE FIELD BEHAVIOUR NEAR A RIGID SPHERE

Waterhouse [12, 13] has derived an analytical expression for the mean square pressure near a rigid sphere in a diffuse field. His derivation was based on the idea that when there is random incidence, the mean square pressure of the wave trains are additive and the total mean square pressure at any point on a sphere of radius a is

$$\langle |p(a)|^2 \rangle = \frac{1}{4\pi a^2} \oint p(a, \theta) p^*(a, \theta) ds, \quad (\text{A1.1})$$

where an asterisk denotes the complex conjugate. This equation represents the mean square pressure distribution for one incident wave train averaged over the surface of the sphere. The element of surface area on the sphere is ds . This concept can be used to derive an analytical expression for the cross-correlation function of the pressure in a diffuse field near a rigid sphere. One starts by assuming a plane wave incident on a rigid sphere of radius a , the centre of which is taken as the origin of the spherical co-ordinates. The plane wave, the direction of incidence of which is taken as $\theta = 0$, can be expressed as

$$p_i = p_{i_{\max}} \sum_{m=0}^{\infty} (2m+1)(j^m) j_m(kr) P_m(\cos \theta), \quad (\text{A1.2})$$

where $p_{i_{\max}}$ is the amplitude of the incident plane wave, m is the order of the spherical harmonic, $j_m(kr)$ is the spherical Bessel function of order m evaluated at a distance r from the centre of the sphere, $P_m(\cos \theta)$ is the Legendre polynomial of order m , k is the wavenumber and $j = \sqrt{-1}$.

The solution of the wave equation which represents the incident wave and the scattered field for a perfectly reflecting sphere can be expressed as [12]

$$\begin{aligned} p(r, \theta) &= p_{i_{\max}} \sum_{m=0}^{\infty} (2m+1)(j^m) e^{-j\delta_{ms}} [\cos \delta_{ms} j_m(kr) + \sin \delta_{ms} n_m(kr)] P_m(\cos \theta) \\ &= p_{i_{\max}} \sum_{m=0}^{\infty} C_m(k, r) P_m(\cos \theta), \end{aligned} \quad (\text{A1.3})$$

where

$$C_m(kr) = (2m+1)(j^m) e^{-j\delta_{ms}} [\cos \delta_{ms} j_m(kr) + \sin \delta_{ms} n_m(kr)], \quad (\text{A1.4})$$

$$\delta_{ms} = \tan^{-1} (-j'_m(ka)/n'_m(ka)), \quad (\text{A1.5})$$

n_m is the spherical Neumann function of order m and j'_m and n'_m are the first derivatives of j_m and n_m respectively.

The mean square pressure at any field point on or outside the sphere due to a single plane wave is

$$|p(r, \theta)|^2 = p(r, \theta)p^*(r, \theta). \quad (\text{A1.6})$$

For random sound incidence, one must average over all directions of incidence. The result of averaging over a spherical surface the acoustic field $|p(r, \theta)|^2$ caused by a plane wave incident from the $\theta = 0$ direction is, by symmetry, the same as if the field point were kept constant and the average taken over all directions of incidence. The former average used here is convenient as it enables one to dispense with the cumbersome biaxial from equation (A1.3). This gives

$$\langle |p(r)|^2 \rangle = \frac{1}{4\pi r^2} \int_0^\pi |p(r, \theta)|^2 2\pi r^2 \sin \theta \, d\theta = \frac{1}{2} \int_0^\pi p(r, \theta)p^*(r, \theta) \sin \theta \, d\theta, \quad (\text{A1.7})$$

where $p(r, \theta)$ is given by equation (A1.3). The term inside the integral in equation (A1.7) is a doubly infinite series which has the properties of convergence and continuity required for term by term integration and differentiation to be valid. The infinite series involved contain θ only in the Legendre functions $P_m(\cos \theta)$ which are orthogonal: that is,

$$\int_0^\pi P_m(\cos \theta)P_n(\cos \theta) \sin \theta \, d\theta = \begin{cases} 0, & m \neq n \\ 2/(2m+1), & m = n \end{cases}. \quad (\text{A1.8})$$

Therefore, all the cross-terms of the product $p(r, \theta)p^*(r, \theta)$ for which $m \neq n$ vanish when the integration (A1.7) is carried out. Applying expression (A1.8), to equation (A1.7) gives

$$\langle |p(r)|^2 \rangle = |p_{i_{\max}}|^2 \sum_{m=0}^{\infty} \frac{2}{2m+1} [C_m(kr)]^2, \quad (\text{A1.9})$$

which can be simplified as

$$\langle |p(r)|^2 \rangle = 2|p_{i_{\max}}|^2 \sum_{m=0}^{\infty} (2m+1)[C'_m(kr)]^2, \quad (\text{A1.10})$$

with

$$C'_m(kr) = (j^m)[\cos \delta_{ms} j_m(kr) + \sin \delta_{ms} \Omega_m(kr)].$$

Similarly, to calculate the cross-correlation function of the acoustic pressure near a sphere, one can express the total pressure at two points r_o and $r_o + \Delta r$ due to an incident plane wave with direction $\theta = 0$ as

$$p(r_o, \theta) = p_{i_{\max}} \sum_{m=0}^{\infty} C_m(kr_o)P_m(\cos \theta), \quad (\text{A1.11})$$

$$p(r_o + \Delta r, \theta) = p_{i_{\max}} \sum_{m=0}^{\infty} C_m(k(r_o + \Delta r))P_m(\cos \theta), \quad (\text{A1.12})$$

where C_m was defined in equation (A1.4). To calculate the expected value of the product of the last two pressures one can average over all directions of incidence: that is,

$$\langle p(r_o)p^*(r_o + \Delta r) \rangle = \frac{1}{2} \int_0^\pi p(r_o, \theta)p^*(r_o + \Delta r, \theta) \sin \theta \, d\theta. \quad (\text{A1.13})$$

According to equation (A1.8), the integration of equation (A1.13) yields

$$\langle p(r_o)p^*(r_o + \Delta r) \rangle = 2|p_{i_{\max}}|^2 \sum_{m=0}^{\infty} \frac{1}{2m+1} C_m(kr_o)C_m^*(k(r_o + \Delta r)). \quad (\text{A1.14})$$

Normalizing this last equation with respect to the mean square pressure at r_o , (A1.10), and simplifying gives

$$\frac{\langle p(r_o)p^*(r_o + \Delta r) \rangle}{\langle |p(r_o)|^2 \rangle} = \frac{\sum_{m=0}^{\infty} (2m+1)C_m'(kr_o)C_m'^*(k(r_o + \Delta r))}{\sum_{m=0}^{\infty} (2m+1)[C_m'(kr_o)]^2}, \quad (\text{A1.15})$$

which is the normalized cross-correlation function of the pressure in a diffuse field diffracted by a rigid sphere of radius a .

APPENDIX 2: DIFFUSE FIELD BEHAVIOUR NEAR A REFLECTING WALL

Waterhouse derived an analytical expression for the interference pattern in a diffuse field near a rigid wall. He found that the mean square pressure averaged for waves incident on a wall from all directions over a hemisphere is [9]

$$\langle |p(x)|^2 \rangle = 1 + \text{sinc}(2kx), \quad (\text{A2.1})$$

where k is the wavenumber. Waterhouse used a simple approach which is adopted here in order to derive an analytical expression for the cross-correlation function of the pressure in a diffuse field near a rigid wall. In Figure A2.1 the reflecting surface is considered to be a rigid wall or boundary large compared with the wavelength. Under this condition, sound energy can reach the point $(x, 0, 0)$ only from the hemisphere to the right of XOZ .

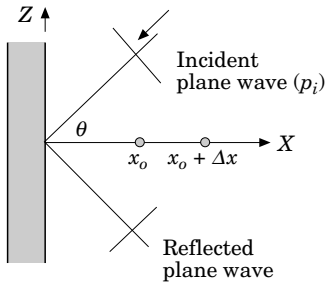

Figure A2.1. An incident plane wave, p_i , reflected by a rigid wall.

Consider a plane wave of unit amplitude incident at an angle θ with the x -axis, producing pressures at x_o and $x_o + \Delta x$ given by

$$p_i(x_o) = \cos(\omega t), \quad p_i(x_o + \Delta x) = \cos(\omega t - k\Delta x \cos \theta). \quad (\text{A2.2, 2.3})$$

Thus, the pressures produced by the reflected wave at these points are

$$p_r(x_o) = \cos(\omega t + 2kx_o \cos \theta), \quad (\text{A2.4})$$

$$p_r(x_o + \Delta x) = \cos(\omega t + k(2x_o + \Delta x) \cos \theta). \quad (\text{A2.5})$$

The total pressure is the sum of the incident and the reflected components. Thus,

$$p(x_o) = p_i(x_o) + p_r(x_o) = \cos(\omega t) + \cos(\omega t + 2kx_o \cos \theta), \quad (\text{A2.6})$$

$$\begin{aligned} p(x_o + \Delta x) &= p_i(x_o + \Delta x) + p_r(x_o + \Delta x) \\ &= \cos(\omega t - k\Delta x \cos \theta) + \cos(\omega t + k(2x_o + \Delta x) \cos \theta). \end{aligned} \quad (\text{A2.7})$$

From equations (A2.6) and (A2.7) one can calculate the mean value of the product $p(x_o)p(x_o + \Delta x)$: i.e.,

$$\overline{p(x_o)p(x_o + \Delta x)} = \frac{1}{T} \int_0^T p(x_o)p(x_o + \Delta x) dt, \quad (\text{A2.8})$$

where $T = 2\pi/\omega$ is the period of the wave. After integration of equation (A2.8) one obtains

$$\overline{p(x_o)p(x_o + \Delta x)} = \cos(k\Delta x \cos \theta) + \cos(k(2x_o + \Delta x) \cos \theta). \quad (\text{A2.9})$$

The expression for the spatial average of the product of the pressures at x_o and $x_o + \Delta x$ in a diffuse acoustic field diffracted by a wall can be calculated by averaging equation (A2.9) for waves incident from all directions over a hemisphere: i.e.,

$$\langle p(x_o)p(x_o + \Delta x) \rangle = \frac{1}{2\pi} \int_0^{2\pi} \int_0^{\pi/2} \overline{p(x_o)p(x_o + \Delta x)} \sin \theta d\phi d\theta, \quad (\text{A2.10})$$

where ϕ is the azimuthal angle which can vary from 0 to 2π and $\langle \rangle$ denotes the spatial average. The integral (A2.10) can be broken down into two simpler integrals, as

$$\begin{aligned} \langle p(x_o)p(x_o + \Delta x) \rangle &= \frac{1}{2\pi} \int_0^{2\pi} \int_0^{\pi/2} \cos(k\Delta x \cos \theta) \sin \theta d\phi d\theta \\ &\quad + \frac{1}{2\pi} \int_0^{2\pi} \int_0^{\pi/2} \cos(k(2x_o + \Delta x) \cos \theta) \sin \theta d\phi d\theta. \end{aligned} \quad (\text{A2.11})$$

The first integral can be solved by putting $v = k\Delta x \cos \theta$, and the second by putting $v = k(2x_o + \Delta x) \cos \theta$. After integration, equation (A2.11) gives

$$\langle p(x_o)p(x_o + \Delta x) \rangle = \text{sinc}(k\Delta x) + \text{sinc}(k(2x_o + \Delta x)), \quad (\text{A2.12})$$

which is the cross-correlation function of a diffuse field diffracted by a rigid wall. If $\Delta x = 0$, then equation (A2.12) gives the spatial averaged mean square pressure at x_o : i.e.,

$$\langle |p(x_o)|^2 \rangle = 1 + \text{sinc}(2kx_o), \quad (\text{A2.13})$$

which agrees with equation (A2.1), as expected.

APPENDIX 3: DIFFUSE FIELD BEHAVIOUR NEAR AN EDGE AND A CORNER

In this appendix an expression is derived for the cross-correlation function in a diffuse field near a corner and a two-wall edge. The wave approach used here is similar to that presented in Appendix 2 and is based on the approach developed by Waterhouse [9, 14]. If one associates a co-ordinate plane to each of the reflecting walls in a corner as shown in Figure A3.1, the pressure at a point (x, y, z) due to one incident plane wave of unit amplitude and all its reflections can be expressed as [9]

$$\begin{aligned} p(x, y, z) = e^{j\omega t} [& \exp(-jk(a' + b' + c')) + \exp(-jk(-a' + b' + c')) \\ & + \exp(-jk(a' - b' + c')) + \exp(-jk(a' + b' - c')) \\ & + \exp(-jk(a' - b' - c)) \\ & + \exp(-jk(a' - b' - c')) + \exp(-jk(-a' + b' - c')) \\ & + \exp(-jk(-a' - b' - c))], \end{aligned} \quad (\text{A3.1})$$

where $a' = x \cos \theta$, $b' = y \sin \theta \cos \phi$ and $c' = z \sin \theta \sin \phi$. In equation (A3.1), the first term represents the incident wave, the next three terms represent the waves reflected in the planes YOZ , XOZ and XOY , the next three terms represent the waves reflected in the planes XOY and XOZ , YOZ and XOZ , and XOZ and ZOY , and the final term represents the wave reflected in all three co-ordinate planes. From equation (A3.1), the pressure at the points (x_o, y_o, z_o) and $(x_1, y_1, z_1) = (x_o + \Delta x, y_o + \Delta y, z_o + \Delta z)$ can be expressed by using the simplified expressions [9]

$$p(x_o, y_o, z_o) = -8 \cos(kx_o \cos \theta) \cos(ky_o \sin \theta \cos \phi) \cos(kz_o \sin \theta \sin \phi) e^{j\omega t}, \quad (\text{A3.2})$$

$$p(x_1, y_1, z_1) = -8 \cos(kx_1 \cos \theta) \cos(ky_1 \sin \theta \cos \phi) \cos(kz_1 \sin \theta \sin \phi) e^{j\omega t}. \quad (\text{A3.3})$$

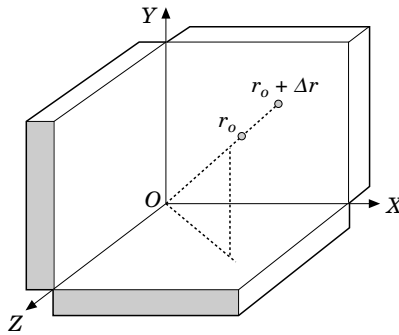

Figure A3.1. The co-ordinate system used to derive the average diffuse field zone of quiet near a corner.

The mean value of the product of these two pressures is

$$\begin{aligned}
& \overline{p(x_o, y_o, z_o)p(x_1, y_1, z_1)} \\
&= \frac{1}{T} \int_0^T p(x_o, y_o, z_o)p(x_1, y_1, z_1) dt \\
&= 32[\cos(kx_o \cos \theta) \cos(kx_1 \cos \theta) \cos(ky_o \sin \theta \cos \phi) \cos(ky_1 \sin \theta \cos \phi) \\
&\quad \times \cos(kz_o \sin \theta \sin \phi) \cos(kz_1 \sin \theta \sin \phi)]. \tag{A3.4}
\end{aligned}$$

For a diffuse sound field with waves of random phase incident from all directions equally over the positive octant, the spatial average of the expression (A3.4) is

$$\langle p(x_o, y_o, z_o)p(x_1, y_1, z_1) \rangle = \frac{2}{\pi} \int_0^{\pi/2} \int_0^{\pi/2} \overline{p(x_o, y_o, z_o)p(x_1, y_1, z_1)} \sin \theta d\theta d\phi, \tag{A3.5}$$

where $\langle \rangle$ denotes the spatial average taken over an octant. The term in brackets in the double integral in this equation can be expressed in a more convenient way if one takes into account the trigonometric relationships

$$\cos(kx_1 \cos \theta) \cos(kx_o \cos \theta) = \frac{1}{2}[\cos(k(x_o + x_1) \cos \theta) + \cos(k(x_1 - x_o) \cos \theta)], \tag{A3.6}$$

$$\begin{aligned}
& \cos(ky_1 \sin \theta \cos \phi) \cos(ky_o \sin \theta \cos \phi) \\
&= \frac{1}{2}[\cos(k(y_o + y_1) \sin \theta \cos \phi) + \cos(k(y_1 - y_o) \sin \theta \cos \phi)], \tag{A3.7}
\end{aligned}$$

$$\begin{aligned}
& \cos(kz_1 \sin \theta \sin \phi) \cos(kz_o \sin \theta \sin \phi) \\
&= \frac{1}{2}[\cos(k(z_o + z_1) \sin \theta \sin \phi) + \cos(k(z_1 - z_o) \sin \theta \sin \phi)]. \tag{A3.8}
\end{aligned}$$

Substituting equations (A3.6), (A3.7) and (A3.8) in equation (A3.5) an integrating gives

$$\begin{aligned}
\langle p(x_o, y_o, z_o)p(x_1, y_1, z_1) \rangle &= \langle p(x_o, y_o, z_o)p(x_o + \Delta x, y_o + \Delta y, z_o + \Delta z) \rangle \\
&= \text{sinc}(k\sqrt{(\Delta x)^2 + (\Delta y)^2 + (\Delta z)^2}) \\
&\quad + \text{sinc}(k\sqrt{(\Delta x)^2 + (\Delta y)^2 + (2z_o + \Delta z)^2}) \\
&\quad + \text{sinc}(k\sqrt{(\Delta x)^2 + (2y_o + \Delta y)^2 + (\Delta z)^2}) \\
&\quad + \text{sinc}(k\sqrt{(\Delta x)^2 + (2y_o + \Delta y)^2 + (2z_o + \Delta z)^2}) \\
&\quad + \text{sinc}(k\sqrt{(2x_o + \Delta x)^2 + (\Delta y)^2 + (\Delta z)^2}) \\
&\quad + \text{sinc}(k\sqrt{(2x_o + \Delta x)^2 + (\Delta y)^2 + (2z_o + \Delta z)^2}) \\
&\quad + \text{sinc}(k\sqrt{(\Delta x)^2 + (2y_o + \Delta y)^2 + (\Delta z)^2}) \\
&\quad + \text{sinc}(k\sqrt{(2x_o + \Delta x)^2 + (2y_o + \Delta y)^2 + (2z_o + \Delta z)^2}). \tag{A3.9}
\end{aligned}$$

If one is concerned only with field points lying on line of symmetry defined by $x = y = z = r/\sqrt{3}$, then equation (A3.9) can be simplified as

$$\begin{aligned}
\langle p(r_o)p(r_o + \Delta r) \rangle &= \text{sinc}(k\Delta r) + 3 \text{sinc}(k\sqrt{2(\Delta r)^2 + (2r_o + \Delta r)^2}/\sqrt{3}) \\
&\quad + 3 \text{sinc}(k\sqrt{(\Delta r)^2 + 2(2r_o + \Delta r)^2}/\sqrt{3}) + \text{sinc}(k(2r_o + \Delta r)), \tag{A3.10}
\end{aligned}$$

where $r_o = \sqrt{x_o^2 + y_o^2 + z_o^2}$ is the distance from the field point to the intersection point of the tree reflecting planes and $\Delta r = \sqrt{3}\Delta x = \sqrt{3}\Delta y = \sqrt{3}\Delta z$ is measured along the line of symmetry of the corner (see Figure A3.1). If one makes $\Delta r = 0$ in equation (A3.10), one obtains

$$\langle |p(r_o)|^2 \rangle = 1 + 3 \operatorname{sinc}(2kr_o/\sqrt{3}) + 3 \operatorname{sinc}(2\sqrt{2/3}kr_o) + \operatorname{sinc}(2kr_o), \quad (\text{A3.11})$$

which coincides with the result derived by Waterhouse for the average mean square pressure in a diffracted diffuse field along the line of symmetry of a corner [9].

The previous derivation can be repeated for the case of a diffracted diffuse field near a two-wall edge. In this case the plane YOZ is not reflecting acoustic energy and all the exponential terms in equation (A3.1) with a negative sign affecting the a' -term have to be cancelled. This means that the pressure at point (x, y, z) due to one incident plane wave of unit amplitude reflected only at the planes XOZ and XOY can be expressed as

$$p(x, y, z) = e^{j\omega t} [\exp(-jk(a' + b' + c')) + \exp(-jk(a' - b' + c')) \\ + \exp(-jk(a' + b' - c')) + \exp(-jk(a' - b' - c))], \quad (\text{A3.12})$$

with a' , b' and c' defined as in equation (A3.1). By following the same procedure described above for the case of a corner, the cross-correlation function of the diffuse field pressure near a two-wall edge is found to be

$$\langle p(y_o, z_o)p(y_o + \Delta y, z_o + \Delta z) \rangle \\ = \operatorname{sinc}(k\sqrt{(\Delta y)^2 + (\Delta z)^2}) + \operatorname{sinc}(k\sqrt{(\Delta y)^2 + (2z_o + \Delta z)^2}) \\ + \operatorname{sinc}(k\sqrt{(2y_o + \Delta y)^2 + (\Delta z)^2}) + \operatorname{sinc}(k\sqrt{(2y_o + \Delta y)^2 + (2z_o + \Delta z)^2}). \quad (\text{A3.13})$$

This equation does not depend on the co-ordinate x_o due to the fact that, for the case of a two-wall edge, the plane YOZ in Figure A3.1 does not represent a rigid wall. If equation (A3.13) is evaluated at points lying on the line of symmetry of a two-wall edge, one obtains

$$\langle p(r_o)p(r_o + \Delta r) \rangle = \operatorname{sinc}(k\Delta r) + 2 \operatorname{sinc}(k\sqrt{(\Delta r)^2 + (2r_o + \Delta r)^2}/\sqrt{2}) + \operatorname{sinc}(k(2r_o + \Delta r)), \quad (\text{A3.14})$$

where $r_o = \sqrt{x_o^2 + y_o^2}$ and $\Delta r = \sqrt{2}\Delta x = \sqrt{2}\Delta y$. Making $\Delta r = 0$ in equation (A3.14) gives

$$\langle |p(r_o)|^2 \rangle = 1 + 2 \operatorname{sinc}(\sqrt{2}kr_o) + \operatorname{sinc}(2kr_o), \quad (\text{A3.15})$$

which coincides with the result derived by Waterhouse for the average mean square pressure in a diffracted diffuse field along the line of symmetry of a two-wall edge [9].