



# OPTIMUM PARAMETERS OF MULTIPLE TUNED MASS DAMPERS FOR BASE-EXCITED DAMPED SYSTEMS

A. S. JOSHI AND R. S. JANGID

*Department of Civil Engineering, Indian Institute of Technology, Bombay 400076, India*

*(Received 23 January 1996, and in final form 16 October 1996)*

The optimum parameters of multiple tuned mass dampers (MTMD) for suppressing the dynamic response of a base-excited structure in a specific mode is investigated. The base excitation is modelled as a stationary white noise random process. The stationary response of the structure with MTMD is analyzed for the optimum parameters of the MTMD system. The criterion selected for optimality is the minimization of the root mean square (r.m.s.) displacement of the main structure. The parameters of MTMD that are optimized include the damping ratio, the tuning frequency ratio and the frequency bandwidth of the MTMD system. The optimum parameters of the MTMD system and corresponding effectiveness are obtained for different damping ratios of the main structure and mass ratios of the MTMD system. In addition, the effectiveness of an optimally designed MTMD system is compared with that of an optimum single tuned mass damper. It is shown that the optimally designed MTMD system is more effective for vibration control than the single tuned mass damper.

© 1997 Academic Press Limited

## 1. INTRODUCTION

The tuned mass damper (TMD) is a classical engineering device consisting of a mass, a spring and a viscous damper, attached to a vibrating main system in order to attenuate any undesirable vibration. The natural frequency of the damper system is tuned to a frequency near to the natural frequency of the main system. The vibration of the main system causes the damper to vibrate in resonance, and as a result, the vibration energy is dissipated through the damping in the tuned mass damper. The solution for determining the optimum tuning frequency and the optimum damping of the tuned mass damper for an undamped main system subjected to harmonic external force over a broad band of forcing frequencies is described in Brock [1] and Den Hartog [2]. Using Den Hartog's procedure, Warburton and Ayorinde [3] have derived the optimum damper parameters for the undamped main system subjected to an harmonic support motion, where the acceleration amplitude is fixed for all input frequencies and other kinds of harmonic excitation sources. The explicit formulae for the optimum parameters of a tuned mass damper and its effectiveness are available under different types of system excitation [4–10].

The main disadvantage of a single tuned mass damper is its sensitivity of the effectiveness to the error in the natural frequency of the structure and/or that in the damping ratio of the tuned mass damper. The effectiveness of a tuned mass damper is reduced significantly by mistuning or off-optimum damping. As a result, the use of more than one tuned mass damper with differing dynamic characteristics, has been proposed in order to improve the effectiveness. Iwanami and Seto [11] have shown that two tuned mass dampers are more effective than a single tuned mass damper. However, the improvement of the effectiveness

was not significant. Recently, multiple tuned mass dampers with distributed natural frequencies have been proposed by Xu and Igusa [12, 13] and also studied by Yamaguchi and Harnpornchai [14], Abe and Fujino [15], Jangid [16], Abe and Igusa [17] and Jangid and Datta [18]. It is shown that the MTMD is more effective for vibration control as compared to the single TMD. Also, the effectiveness of the MTMD is not much influenced by the change or estimation error in the natural frequency of the structure.

In spite of several studies on the effectiveness of the MTMD, the optimum parameters of the MTMD system have not yet been studied. Here, the optimum parameters of the MTMD system for a base-excited main system are presented. The criterion selected for optimality is minimization of the r.m.s. displacement of the main system. The base excitation is modelled as a white noise stationary random process. The optimum parameters of the MTMD system are obtained for different damping ratios of the main system and mass ratios of the MTMD, which may find application in the effective design of MTMD's for base-excited systems. Furthermore, the optimum parameters of the MTMD system are compared with those of a corresponding single tuned mass damper system.

## 2. STRUCTURAL MODEL

The system configuration consists of a main system supported by  $n$  tuned mass dampers with different dynamic characteristics, as shown in Figure 1. The main system is characterized by natural frequency  $\omega_s$ , damping ratio  $\zeta_s$  and mass  $m_s$ . The main system and each TMD is modelled as a single-degree-of-freedom system so that the total degrees of freedom of the structural system is  $n + 1$ . The various assumptions made for the system under consideration are as follows: (i) the natural frequencies of the main structure are not closely spaced; (ii) the vibration to be suppressed is only in the specific vibration mode; (iii) the stiffness and damping of each TMD is the same; and (iv) the natural frequencies of the MTMD are uniformly distributed around their average natural frequency. The distribution of natural frequencies of the MTMD can be made by varying either the stiffness or mass of each TMD. However, the manufacturing of a TMD with uniform stiffness and constant damping is simpler than that of one with varying stiffness and

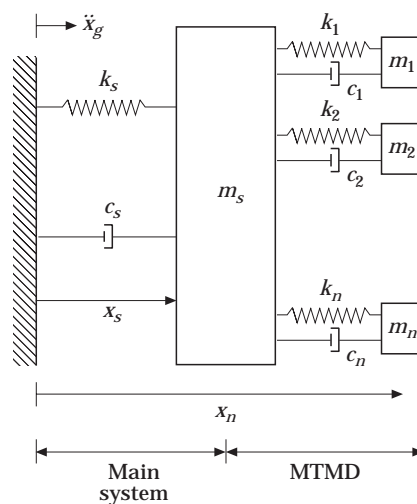

Figure 1. The structural model.

damping properties (the mass remains unchanged). Note that MTMD's with identical dynamic characteristics are equivalent to a single TMD in which the damping ratio and natural frequency of the equivalent single TMD are the same as those of the individual MTMD. However, the mass is the sum of all the MTMD's masses. The model considered above is the same as given by Xu and Igusa [12]. However, for the sake of completeness, the system parameters used for the present optimization study are briefly summarized below.

Let  $\omega_T$  be the average frequency of all MTMD's (i.e.,  $\omega_T = \sum_{j=1}^n \omega_j/n$ ), where  $n$  is the total number of MTMD's. The natural frequency of the  $j$ th TMD is expressed as (a list of notation is given in the Appendix)

$$\omega_j = \omega_T \left[ 1 + \left( j - \frac{n+1}{2} \right) \frac{\beta}{n-1} \right], \tag{1}$$

where the parameter  $\beta$  is the non-dimensional frequency spacing of the MTMD, defined as

$$\beta = \frac{\omega_n - \omega_1}{\omega_T}. \tag{2}$$

If  $k_T$  and  $c_T$  are the constant stiffness and damping of each TMD, respectively, then the mass and damping ratio of the  $j$ th TMD are expressed as

$$m_j = k_T/\omega_j^2, \quad \zeta_j = c_T/2m_j\omega_j = (c_T/2k_T)\omega_j. \tag{3, 4}$$

Note that the masses of the MTMD's in equation (3) follow an inverse quadratic relation to the natural frequency of the TMD. However, in reference [13] it has been shown that the masses should follow an elliptical relation with frequency under optimal condition. A more complex relation has also been proposed in reference [15].

The average damping ratio of the MTMD is expressed as

$$\zeta_T = \sum_{j=1}^n \frac{\zeta_j}{n} = \frac{\omega_T c_T}{2k_T}. \tag{5}$$

The ratio of the total MTMD's mass to the main system's mass is defined as the mass ratio; i.e.,

$$\gamma = \frac{\sum_{j=1}^n m_j}{m_s} = \frac{m_T}{m_s}, \tag{6}$$

where  $m_T$  is the total mass of the MTMD; and  $m_s$  is the mass of the main system.

The constant stiffness and damping of each TMD may be evaluated using

$$k_T = \gamma m_s \left/ \left( \sum_{j=1}^n \frac{1}{\omega_j^2} \right) \right., \quad c_T = 2\zeta_T \gamma m_s \left/ \left( \omega_T \sum_{j=1}^n \frac{1}{\omega_j^2} \right) \right. \tag{7, 8}$$

The ratio of the average frequency of the MTMD to the natural frequency of the main system is defined as the tuning frequency ratio; i.e.,

$$f = \omega_T/\omega_s. \tag{9}$$

### 2.1. RESPONSE TO STATIONARY EXCITATION

The governing equations of motion for the system under consideration are given in reference [12]. Furthermore, the amplitude of the steady state harmonic displacement of the main system,  $x_s(\omega)$ , to the harmonic base acceleration,  $\ddot{x}_g = e^{i\omega t}$  (where  $\omega$  is the circular frequency and  $i = \sqrt{-1}$ ) is given by

$$x_s(\omega) = \frac{m_s - (i\omega)^{-1}Z(\omega)}{k_s - i\omega c_s - \omega^2 m_s - i\omega Z(\omega)}, \quad (10)$$

where

$$Z(\omega) = -i\omega \sum_{j=1}^n \frac{m_j(k_j - i\omega c_j)}{k_j - i\omega c_j - \omega^2 m_j}. \quad (11)$$

If the base excitation is modelled as a stationary random process characterized by its power spectral density function (PSDF), then the PSDF of the displacement of main system [19] is given by

$$S_{x_s}(\omega) = |x_s(\omega)|^2 S_{\ddot{x}_g}(\omega), \quad (12)$$

where  $S_{\ddot{x}_g}(\omega)$  is the PSDF function of the ground acceleration.

The mean square displacement of the main system is given by [19]

$$\sigma_{x_s}^2 = \int_{-\infty}^{\infty} S_{x_s}(\omega) d\omega. \quad (13)$$

### 3. NUMERICAL STUDY

The stochastic response of the base-excited main system with the MTMD is investigated for the optimum parameters of the MTMD system. The criterion selected for optimality is minimization of the r.m.s. displacement of the main system. The base excitation is modelled as a stationary white noise random process; i.e.,

$$S_{\ddot{x}_g}(\omega) = S_0, \quad -\infty \leq \omega \leq \infty. \quad (14)$$

The effectiveness of the MTMD is defined by its equivalent damping added to the main system. The equivalent damping of the MTMD system is expressed by

$$\zeta_{eq} = \frac{\pi S_0}{2\omega_s^3 \sigma_{x_s}^2} - \zeta_s, \quad (15)$$

where  $\sigma_{x_s}^2$  is the mean square displacement of the main system obtained from equation (13). Equation (15) is obtained by equating the mean square displacement of the main system with the MTMD to the equivalent main system response without the MTMD, but with a damping ratio equal to  $\zeta_s + \zeta_{eq}$ . Thus, the effect of the MTMD is considered in terms of the damping added to the main system. Note that  $\zeta_{eq}$  is a measure of the effectiveness of the MTMD system, and that a positive value indicates that the MTMD system is effective in reducing the dynamic response of the main system. The ratio ( $R$ ) of r.m.s.

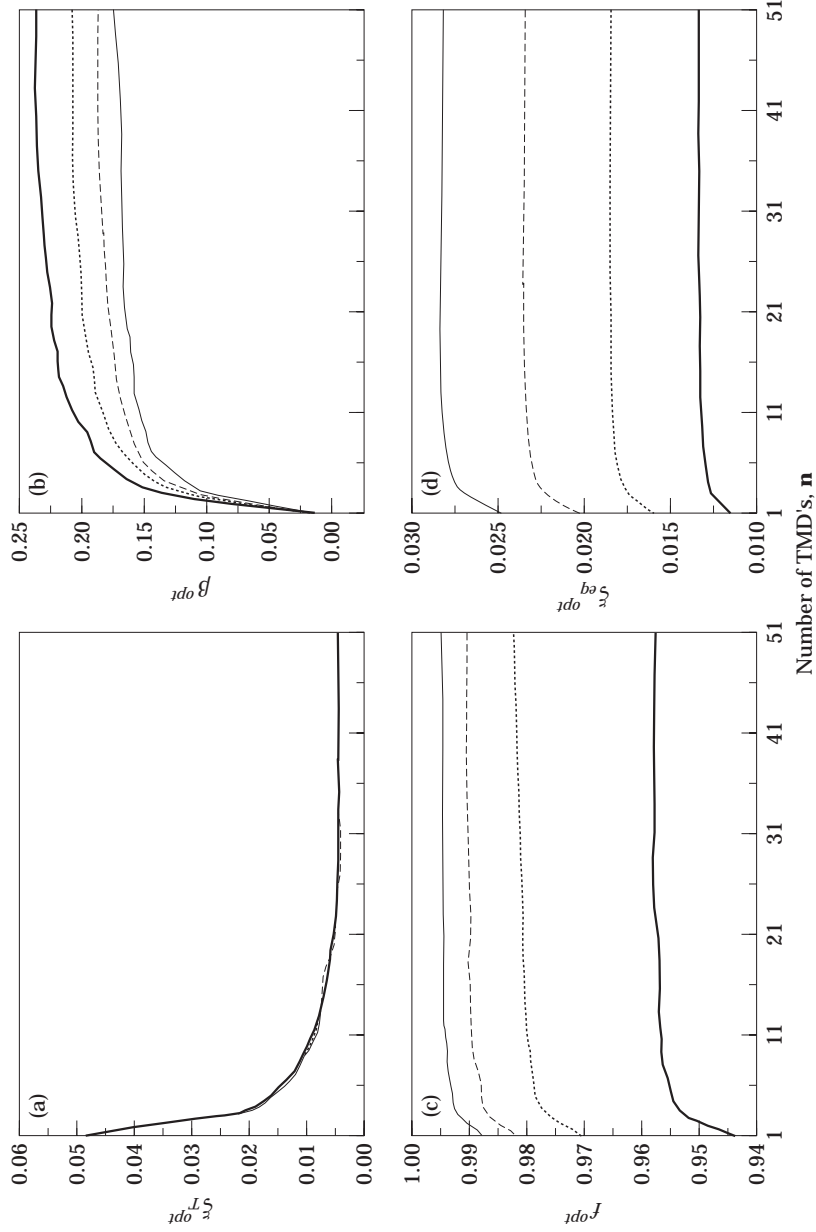

Figure 2. Variation of the optimum parameters (a)  $\zeta_s^{opt}$ , (b)  $\beta^{opt}$ , (c)  $f^{opt}$ , and (d)  $\zeta_s^{opt}$  versus the number of tuned mass dampers, for  $\gamma = 1\%$ .  
 —,  $\zeta_s = 0\%$ ; - - - ,  $\zeta_s = 2\%$ ; ····,  $\zeta_s = 5\%$ ; ———,  $\zeta_s = 10\%$ .

displacement of the main system with the MTMD to that without the MTMD is given by

$$R = \sqrt{\frac{\xi_s}{\xi_s + \xi_{eq}}}. \quad (16)$$

The structural system considered in the present study is quite complex, and it is very tedious to obtain the expression for the optimum parameters in closed form. As a result, the optimum parameters are obtained using a numerical searching procedure. For a given  $\xi_s$ ,  $\gamma$  and  $n$ , the parameters of the MTMD (i.e.,  $\xi_T$ ,  $\beta$  and  $f$ ) are varied such that the r.m.s. displacement of the main system attains the minimum value (i.e.,  $\xi_{eq}$  attains the maximum value). The constraints applied on the values of parameters  $\xi_T$ ,  $\beta$  and  $f$  for the optimization study are as follows:

$$0 \leq \xi_T < 1, \quad 0 \leq \beta < 2, \quad f > 0. \quad (17a-c)$$

The above conditions satisfy the conditions that (i) the natural frequencies of the TMD's are positive real, and (ii) the TMD's are under-damped. The optimum parameters of the MTMD system are obtained for four values of the main system damping; i.e.,  $\xi_s = 0, 2, 5$  and  $10\%$ . The superscript "opt" is used to denote the optimum parameters and corresponding  $\xi_{eq}$  at the optimum parameters.

### 3.1. THE EFFECTS OF THE NUMBER OF MTMD'S ON THE OPTIMUM PARAMETERS

In Figure 2 is shown the variation of the optimum parameters  $\xi_T^{opt}$ ,  $\beta^{opt}$ ,  $f^{opt}$  and  $\xi_{eq}^{opt}$ , versus the number of tuned mass dampers,  $n$  for the mass ratio  $\gamma = 1\%$  and  $\xi_s = 0, 2, 5$  and  $10\%$ . The optimum damping ratio,  $\xi_T^{opt}$ , decreases sharply as the number of TMD's increases. The optimum damping ratio for a single TMD is much higher than that for the MTMD system. Furthermore, the optimum damping is insensitive to changes in the main system damping. Warburton [5] has shown that the optimum damping of the single TMD is not influenced by the damping of the main system, and the same is also confirmed for the MTMD system. The optimum frequency bandwidth,  $\beta^{opt}$ , of the MTMD system increases with the increase in both the number of TMD's as well as the damping of the main structure, as shown in the figure. The optimum tuning frequency ratio,  $f^{opt}$ , increases with an increase in the number of TMD's. However, it remains almost constant beyond

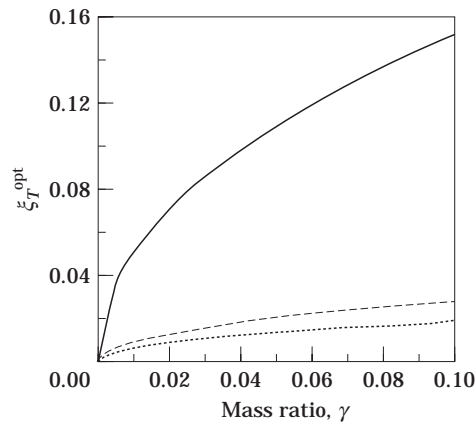

Figure 3. Variation of the optimum MTMD damping,  $\xi_T^{opt}$ , versus the mass ratio,  $\gamma$ , for  $f = f^{opt}$ ,  $\beta = \beta^{opt}$  and  $\xi_s = 0$ . —,  $n = 1$ ; ----,  $n = 11$ ; ····,  $n = 21$ .

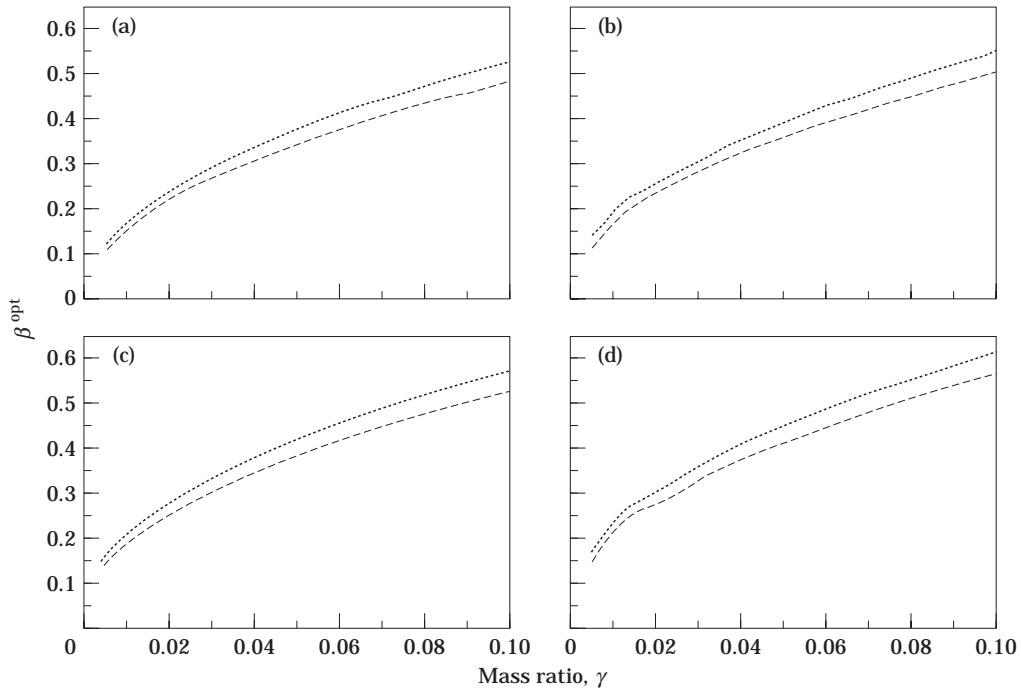

Figure 4. Variation of the optimum frequency range of the MTMD,  $\beta^{opt}$ , versus the mass ratio,  $\gamma$ , for  $f = f^{opt}$ ,  $\xi_T = \xi_T^{opt}$ . (a)  $\xi_s = 0\%$ ; (b)  $\xi_s = 2\%$ ; (c)  $\xi_s = 5\%$ ; (d)  $\xi_s = 10\%$ . ----,  $n = 11$ ; ····,  $n = 21$ .

a certain number of TMD's (in this case for  $n > 5$ ). The optimum tuning frequency for single TMD is smaller than that for the MTMD system. Also, the optimum tuning frequency ratio decreases with an increase in the damping of the main structure. The equivalent damping,  $\xi_{eq}^{opt}$ , added to the main system at the optimum parameters shows a trend very similar to that of the optimum frequency bandwidth. There is an initial steep increase in the value of the equivalent damping. However, as the number of TMD's increases, the equivalent damping remains almost constant. The equivalent damping of the MTMD system is more, although marginally, than that for a single TMD system. Thus, an optimum designed MTMD system is more effective than the optimum single TMD system. Furthermore,  $\xi_{eq}^{opt}$  decreases as the main structure damping increases. This signifies that the effectiveness of the MTMD system decreases as the damping in the main structure increases.

### 3.2. THE EFFECT OF THE MASS RATIO ON THE OPTIMUM PARAMETERS

In this section, the variation of the optimum parameters  $\xi_T^{opt}$ ,  $\beta^{opt}$ ,  $f^{opt}$  and  $\xi_{eq}^{opt}$ , versus the mass ratio,  $\gamma$ , is studied for different number of TMD,  $n = 1, 11$  and  $21$ . In Figure 3 the variation of  $\xi_T^{opt}$  is plotted against the mass ratio for  $\xi_s = 0$ . The optimum damping ratio increases with an increase in the mass ratio, being more pronounced for a single TMD as compared to the MTMD system. The optimum damping ratio for a single TMD is sufficiently larger than that for the MTMD system. Thus, the optimum damping ratio of the MTMD increases with an increase in the mass ratio. Furthermore, it is observed that the optimum damping ratio remains insensitive to variation of the main system damping, and that the graphs for  $\xi_s = 2, 5$  and  $10\%$  are indistinguishable from that of  $\xi_s = 0$ . Therefore, the same plot may be used for the optimum damping of the MTMD system for different damping ratios of the main system.

The variation of the optimum frequency bandwidth of the MTMD system versus the mass ratio is shown in Figure 4. As the mass ratio increases, the optimum frequency bandwidth also increases. The difference in the optimum frequency bandwidth between  $n = 11$  and  $n = 21$  increases mildly with the increase of mass ratio. It can also be seen from the figure that as the main structure damping increases, the optimum frequency bandwidth also increases for a given mass ratio and number of tuned mass dampers. Thus, the optimum frequency bandwidth of the MTMD system increases with an increase in both the mass ratio and the main system damping.

In Figure 5, variation of the optimum tuning frequency ratio,  $f^{opt}$ , is plotted versus the mass ratio. The optimum tuning frequency ratio decreases with an increase in the mass ratio. The difference in the optimum tuning frequency ratio for  $n = 11$  and  $n = 21$  is not significant. For low values of the mass ratio, the optimum tuning ratio is the same for a single TMD and for the MTMD system. The optimum tuning ratio for a single TMD is much lower than that for the MTMD system for higher values of the mass ratio. At a given mass ratio, the optimum tuning frequency ratio increases with an increase in the number of TMD's and decreases with an increase in the main structure damping. Thus, the optimum tuning frequency ratio decreases with an increase in the mass ratio, being more pronounced for a single TMD as compared to the MTMD system.

In Figure 6 is shown the variation of the equivalent damping of the TMD and MTMD added to the main system at the optimum parameters versus the mass ratio,  $\gamma$ . The optimum equivalent damping increases with an increase in the mass ratio. The equivalent damping of the optimum MTMD system is greater compared to that of the optimum single TMD. This indicates that an optimally designed MTMD system is more effective than a single TMD. The optimum equivalent damping added by the MTMD system and a single

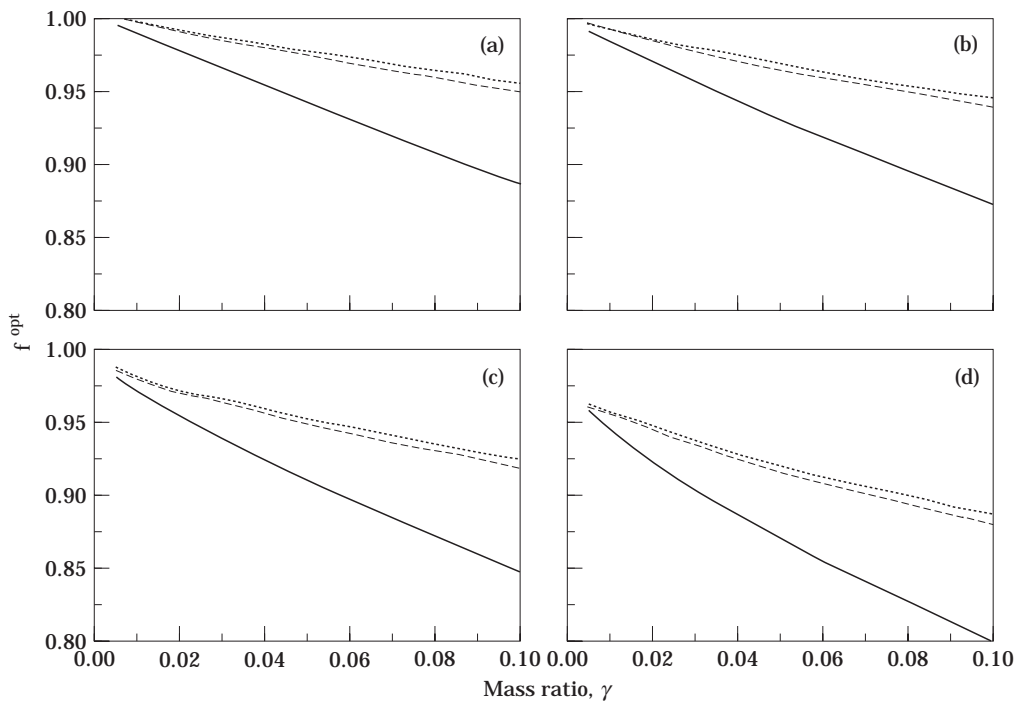

Figure 5. Variation of the optimum tuning frequency ratio,  $f^{opt}$ , versus the mass ratio  $\gamma$ , for  $\beta = \beta^{opt}$  and  $\xi_T = \xi_T^{opt}$ . (a)  $\xi_s = 0\%$ ; (b)  $\xi_s = 2\%$ ; (c)  $\xi_s = 5\%$ ; (d)  $\xi_s = 10\%$ . —,  $n = 1$ ; ---,  $n = 11$ ; ···,  $n = 21$ .



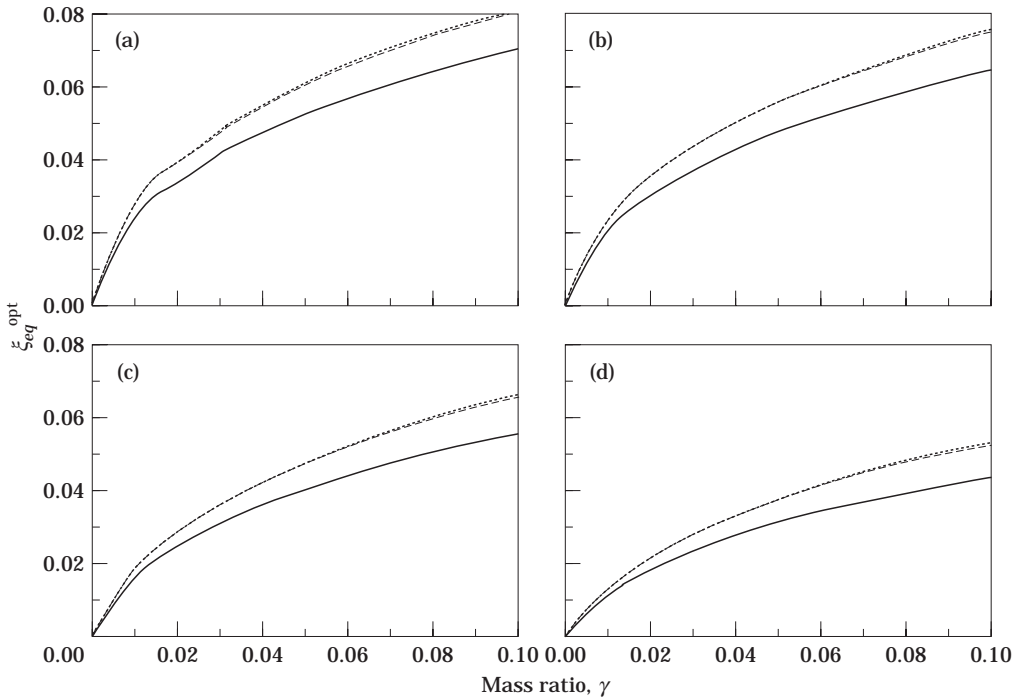

Figure 6. Variation of the optimum equivalent damping ratio,  $\zeta_{eq}^{opt}$ , versus the mass ratio,  $\gamma$ , for  $f = f^{opt}$ ,  $\beta = \beta^{opt}$  and  $\zeta_r = \zeta_r^{opt}$ . (a)  $\zeta_s = 0\%$ ; (b)  $\zeta_s = 2\%$ ; (c)  $\zeta_s = 5\%$ ; (d)  $\zeta_s = 10\%$ . Key as for Figure 5.

TMD is a maximum for the undamped system and decreases with an increase in the main system damping. Thus, the effectiveness of the MTMD system and the single TMD increases with an increase in the mass ratio. However, it is reduced for higher damping in the main system.

4. CONCLUSIONS

The stochastic response of a structure with the MTMD system subjected to base excitation is investigated. The base excitation is modelled as a stationary white noise random process. The optimum parameters of the MTMD system are obtained for minimum r.m.s. displacement of the main structure. The parameters of the MTMD system (i.e., the damping ratio, tuning frequency and frequency spacing) are obtained for different numbers of TMD's, and for different values of the mass ratio and the damping of the main structure. In addition, the optimum parameters of the MTMD system are compared with those corresponding to the single TMD system. From the trends of the results of the present study, the following conclusions may be drawn.

1. For the same mass ratio, the optimum designed MTMD system is found to be more effective than the optimum single TMD system.
2. The optimum damping ratio for the MTMD system is found to be quite low as compared to that of a single TMD. The optimum damping ratio increases with an increase in the mass ratio, being more pronounced for a single TMD system as compared to the MTMD system.
3. The damping in the main system does not influence the optimum damping ratio of both the single TMD and the MTMD system.

4. The optimum frequency bandwidth of the MTMD system increases with an increase in both the mass ratio and the damping of the main system.
5. The optimum tuning frequency of the MTMD system is found to be higher than that for single TMD. Furthermore, the optimum tuning frequency decreases with an increase in both the mass ratio and the damping of the main system.
6. The effectiveness of the MTMD and the single TMD system is reduced for higher damping in the main system.
7. For the MTMD system, the optimum damping ratio decreases whereas the frequency bandwidth increases mildly with an increase in the number of TMD's.
8. The number of TMD's does not have much influence on the optimum tuning frequency and the corresponding effectiveness of the MTMD system.

#### REFERENCES

1. J. E. BROCK 1946 *Journal of Applied Mechanics*, *American Society of Mechanical Engineers A*, 284. A note on the damped vibration absorber.
2. J. P. DEN HARTOG 1956 *Mechanical Vibrations*. New York: McGraw-Hill; fourth edition.
3. G. B. WARBURTON and E. O. AYORINDE 1980 *Earthquake Engineering and Structural Dynamics* **8**, 197–217. Optimum adsorber parameters for simple systems.
4. E. O. AYORINDE and G. B. WARBURTON 1980 *Earthquake Engineering and Structural Dynamics* **8**, 219–236. Minimizing structural vibration with absorbers.
5. G. B. WARBURTON 1981 *Earthquake Engineering and Structural Dynamics* **9**, 251–262. Optimum adsorber parameters for minimizing vibration response.
6. G. B. WARBURTON *Earthquake Engineering and Structural Dynamics* **10**, 381–401. Optimum adsorber parameters for various combinations of response and excitation parameters.
7. H. C. TSAI and G. C. LIN 1993 *Earthquake Engineering and Structural Dynamics* **22**, 957–973. Optimum tuned mass dampers for minimizing steady-state response of support excited and damped system.
8. H. C. TSAI and G. C. LIN 1993 *Journal of Sound and Vibration* **89**, 385–396. Explicit formulae for optimum adsorber parameters for force excited and viscously damped systems.
9. A. G. THOMPSON 1981 *Journal of Sound and Vibration* **77**, 403–415. Optimum tuning and damping of a dynamic vibration adsorber applied to a force excited and damped primary system.
10. Y. FUJINO and M. ABE 1993 *Earthquake Engineering and Structural Dynamics* **22**, 833–854. Design formulas for tuned mass dampers based on a perturbation technique.
11. K. IWANAMI and K. SETO 1984 *Proceedings of the Japan Society of Mechanical Engineers (C)* **50**, 44–52. Optimum design of dual tuned mass dampers with their effectiveness.
12. K. XU and T. IGUSA 1992 *Earthquake Engineering and Structural Dynamics* **21**, 1059–1070. Dynamic characteristics of multiple substructures with closely spaced frequencies.
13. T. IGUSA and K. XU 1994 *Journal of Sound and Vibration* **175**, 491–503. Vibration control using multiple tuned mass dampers.
14. H. YAMAGUCHI and N. HARNPORNCHAI 1993 *Earthquake Engineering and Structural Dynamics* **22**, 51–62. Fundamental characteristics of multiple tuned mass dampers for suppressing harmonically forced oscillations.
15. M. ABE and Y. FUJINO 1994 *Earthquake Engineering and Structural Dynamics* **23**, 813–835. Dynamic characterization of multiple tuned mass dampers and some design formulae.
16. R. S. JANGID 1995 *Structural Engineering and Mechanics* **3**, 497–509. Dynamic characteristics of structures with multiple tuned mass dampers.
17. M. ABE and T. IGUSA 1995 *Earthquake Engineering and Structural Dynamics* **24**, 247–261. Tuned mass dampers for structures with closely spaced frequencies.
18. R. S. JANGID and T. K. DATTA 1997 *Earthquake Engineering and Structural Dynamics* **26**, (in press) Performance of multiple tuned mass dampers for torsionally coupled system.
19. N. C. NIGAM 1983 *Introduction to Random Vibrations*. Cambridge, MA: The MIT Press.

## APPENDIX: NOTATION

$c_j$	damping of the $j$ th TMD
$c_s$	damping of main system
$c_T$	damping constant of each TMD
$f$	tuning frequency ratio
$k_j$	stiffness of the $j$ th TMD
$k_s$	stiffness of main system
$k_T$	constant stiffness of each TMD
$m_j$	mass of the $j$ th TMD
$m_T$	total mass of MTMD
$m_s$	mass of the main system
$n$	number of the tuned mass dampers
$R$	the response ratio
$S_{\ddot{x}_g}(\omega)$	PSDF of the base acceleration
$S_0$	intensity of the white noise excitation
$S_{x_s}(\omega)$	PSDF of the displacement of main system
$x_s$	displacement of the main system relative to ground
$x_j$	displacement of the $j$ th tuned mass damper relative to ground
$\ddot{x}_g$	base acceleration
$\beta$	non-dimensional frequency bandwidth of MTMD system
$\gamma$	mass ratio
$\omega$	circular frequency
$\omega_T$	average natural frequency of the MTMD
$\omega_j$	natural frequency of the $j$ th TMD
$\omega_s$	natural frequency of the main system
$\xi_s$	damping ratio of the main system
$\xi_j$	damping ratio of the $j$ th TMD
$\xi_T$	average damping ratio of MTMD
$\xi_{eq}$	equivalent damping added to main system by MTMD
$\sigma_{x_s}^2$	mean square displacement of the main system

*Superscript*

*opt* optimum value