



EXPERIMENTAL INVESTIGATION OF THE DYNAMIC CHARACTERISTICS OF THE DAMPED BLADE

B. H. JI, G. H. ZHANG, L. T. WANG, Q. YUAN, Q. J. MENG

*Institute of Thermal Turbomachines, Xi'an Jiaotong University, Xi'an, Shaanxi 710049,
People's Republic of China*

AND

D. Y. LIU

*Xi'an Thermal Power Research Institute, Xi'an, Shaanxi 710049,
People's Republic of China*

(Received 6 November 1996, and in final form 18 December 1997)

The test facility and measurement system for the investigation of the dynamic characteristics of a damped blade are described. The test results are analyzed, and some important conclusions are drawn. It is found that dry friction between the dampers (or between damper and blade) is a very effective means of reducing the vibration of a blade. The resonance frequency, the response amplitude and the relative damping ratio can all be influenced by dry friction. High harmonic waves on the response of the blade which are caused by dry friction are observed in the test. However, the wave response of the damped blade is still basically harmonic. The normal force acting on the rub surfaces of the damped blade will influence the dynamic characteristics of the blade. Since the damped blade system is non-linear due to dry friction, the external exciting force can also influence the dynamic characteristics of the blade.

© 1998 Academic Press Limited

1. INTRODUCTION

Economy and safety are two main factors which should be considered during the design of the turbine blade. A blade is required not only to be highly efficient, but also to be sufficiently strong. Cracks caused by vibration are the main type of blade failures. Reducing the vibration of the blade and lowering the stress of the blade is a big challenge. The following main methods exist for reducing the vibration: (1) Grouping the blades by welding which can increase the stiffness of the blades and decrease the group coefficient, and then suppress the stress of the blades. (2) Grouping the blades along a circle by loose lacing wires which can reduce the group coefficient and avoid resonance with exciting forces except for three coincident points resonance (discussed by Wang [1]). (3) Using the damper, for example, the damping lacing wires, integral wire or integral shroud, etc., to decrease the stress of the blade through dry friction. Among the three methods presented above, the last one is the newest and the most efficient way to reduce the vibratory stress of a blade. Because of dry friction, the damped blade system becomes a non-linear system, which results in some new dynamic characteristics of the system. These characteristics are quite different from those of the linear system. Recently Meng and Griffin [2], Meng *et al.* [3] and Srinivasan and Cutts[4] have carried out excellent work in the investigation of

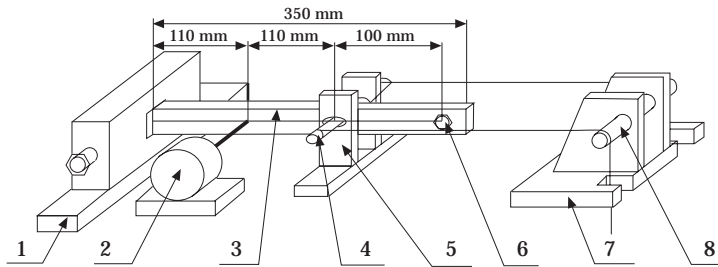

Figure 1. The assemblage of the damped blade system. Key: 1, the blade holder; 2, vibration exciter; 3, blade; 4, damping lacing wire; 5, damper stand; 6, pick-up; 7, pulley stand; 8, pulley.

the characteristics of the damped blade. The design of a damped blade is discussed by Kielb *et al.* [5], which is helpful to blade designers.

In this paper, the experimental investigation of the vibratory characteristics of the damped blade is performed one step further, and then the results will be used in the foundation of the theoretical model of the damped blade. In the experiment the damping lacing wire is used as a damper. Normal force acting on the rub surfaces between the damping lacing wire and blade is produced by the pulling force of the nylon string. Because there is friction motion between the damping lacing wire and the blade, the vibration of the blade is reduced.

2. TEST FACILITY AND MEASURING METHODS

2.1. TESTING APPARATUS

The test facility (see Figure 1) consists of the plate blade (350 mm × 38 mm × 8 mm), the holding device of the blade, the damping lacing wire, the stand of damping lacing wire, the pulley, the pulley stand, the nylon string, the vibration exciter (its maximum exciting force is 20 N), the pick-up transducer, the weight, the hanging pan and the test stand. The material of the blade is 2Cr13 and heat treatment are the same as the actual blade.

2.2. INSTRUMENTATION SYSTEM

The system is shown in Figure 2. The main measuring apparatus are B&K Sine Random Generator (type 1027), B&K type 2706 Power Amplifier, B&K type 2636 Measuring Amplifier, YB-4242 Oscilloscope, SB-14 Double Oscilloscope, B&K type 2636 Charge Amplifier, TEAC MC-30C Cassette Recorder, and HP3562A Dynamic Signal Analyzer.

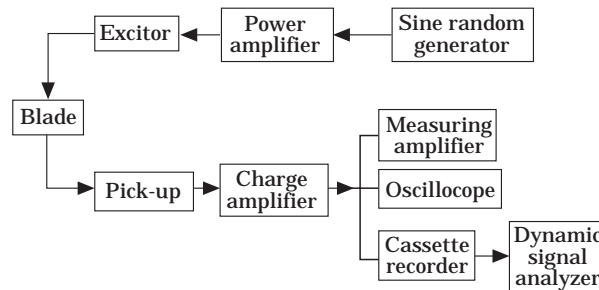

Figure 2. The measuring system of the damped blade.

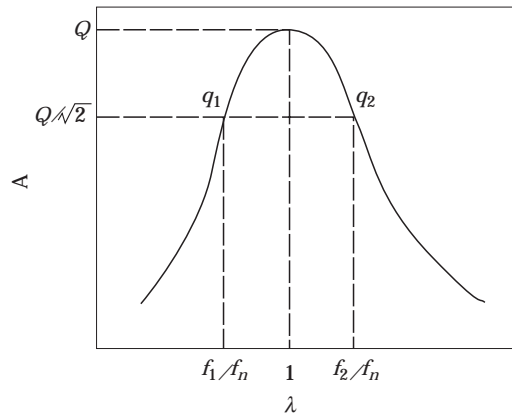

Figure 3. The response–frequency curve.

2.3. MEASURING METHODS

2.3.1. *Measuring the resonant frequency and amplitude of response*

The exciting frequency of the sine random generator is continuously adjusted while the exciting force with the normal force of damping lacing wire remains unvaried. When the Lissajous curve on the oscilloscope becomes a regular ellipse, the blade is in resonance with the exciting force. Then the frequency of the generator is the resonance frequency of the blade, and the indication on the measuring amplifier is the resonance amplitude of the blade response.

2.3.2. *Measuring the relative damping ratio*

The relative damping ratio of the blade is measured by using the semi-power points method. The response frequency curve is supposed to be approximately symmetrical about the line $\lambda = 1$. There is one point at each side of the line $\lambda = 1$, and the value of amplitude of the two points is equal to 70.7% of the tip value of the curve. These two points are called semi-power points (shown in Figure 3). During the test, the sine random generator’s frequency is adjusted until the blade is in resonance, so that one harmonic frequency of the blade f_n is found. Then the generator is adjusted to find the frequencies of the two semi-points q_1 and q_2 . When f_1 and f_2 corresponding respectively to q_1 and q_2 are obtained, the relative damping ratio can be evaluated by:

$$\xi = (f_2 - f_1)/(2f_n). \tag{1}$$

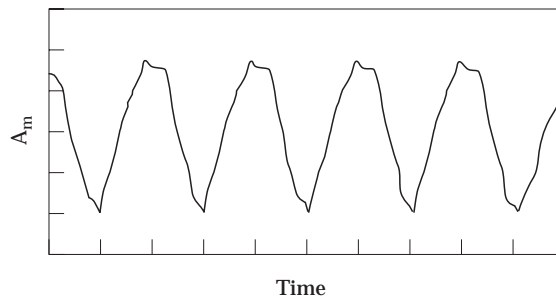

Figure 4. The response waveform of the damped blade.

TABLE 1
The test results of a free blade

Mode	1	2	3
Frequency (Hz)	54.7	337.9	953.1
R.D.R.	0.001851	0.00118382	0.0008023
L.D.R.	0.01162	0.00743437	0.00504

2.3.3. Measuring procedure

When the blade is forced to vibrate by the exciter, the response of the blade is picked up by the transducer fixed on the blade, and the signal is transmitted to the measuring amplifier, oscilloscope and dynamic signal analyzer. The condition under which the blade is excited by a specific exciting force and vibrates at a specific vibration mode is defined as an operating mode. At each operating mode, the frequency, the relative damping ratio and response amplitude are measured as a series of normal forces acting on the damping lacing wire. The first three modes of vibration are measured in this experiment. For each mode, there are three different exciting forces, and so there are nine different operating modes to be measured. At each operating mode, three sets of measurements are required. The normal force varied from 0–200 N, and each value of the normal force is marked as a measuring point. There are generally 16–20 measuring points in one operating mode. When the measurement is finished, the relations between the normal force and the resonance frequency, the relative damping ratio, and response amplitude of the damped blade are obtained.

3. ANALYSIS OF TEST RESULTS

For a proper comparison, the frequency and the relative damping ratio of the free blade (which has no damping lacing wire) are measured first, and the results are listed in Table 1. Then, according to the measuring methods introduced in section 2.3, the response, the relative damping ratio and the resonance frequency of the damped blade are measured at nine different operating modes. The test results are depicted in Figures 5–13 for convenience of analysis.

3.1. ANALYSIS OF THE TEST RESULTS OF A FREE BLADE

The free blade is tested by the shock excitation method. The signal of striking force and decaying signal of the blade response have been recorded on cassette. The data of force and response is read from the cassette and analyzed by the dynamic signal analyzer. The frequencies and the relative damping ratios of the first three modes are evaluated by the analyzer. The results are listed in Table 1, in which R.D.R. indicates the relative damping ratio and L.D.R. indicates the logarithmic decay ratio.

3.2. ANALYSIS OF THE TEST RESULTS OF A DAMPED BLADE

(1) A blade which has no damping lacing wire is called a free blade. When a free blade is excited, its response waveform is a harmonic wave and the Lissajous curve at resonant points is a regular ellipse. When the damping lacing wire is assembled on the blade and the normal force acts on the rub surface, the waveform of the blade response is deformed (see Figure 4). From the figure, higher harmonics can be seen in the fundamental harmonic. It means that the response of the damped blade is the combined motion of the multiple

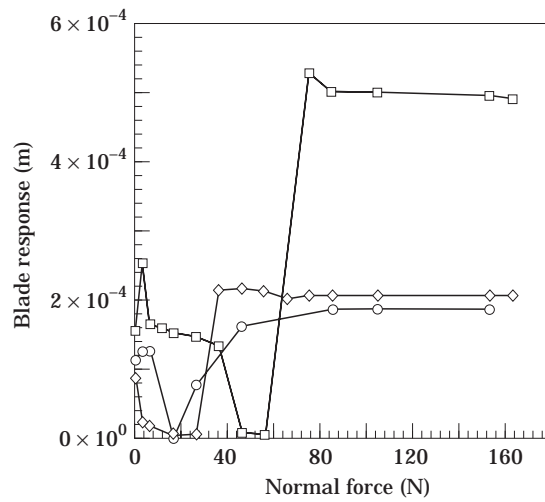

Figure 5. The normal force versus the response of the first mode of the damped blade. Key; —○—, $p1$; —◇—, $p2$; —□—, $p3$.

modes and the waveform becomes disturbed though it is still an approximately harmonic wave. The deformation of the second and the third modes is less severe than that of the first mode.

(2) The relationship of resonant response of the first mode of the damped blade versus the normal force under three different exciting forces is depicted in Figure 5. It is obvious that the three curves have a common feature, i.e., when the normal force is smaller than 16 N, 20 N and 45 N, the response of the damped blade decreases as the normal force increases till the normal force reaches a certain value (16 N, 20 N and 45 N), and the amplitude of response reaches the lowest point. If the normal force still increases, the response amplitude will rise. It indicates that there is an optimum value for the normal force acting on the rub surfaces between the damping lacing wire and blade, where the

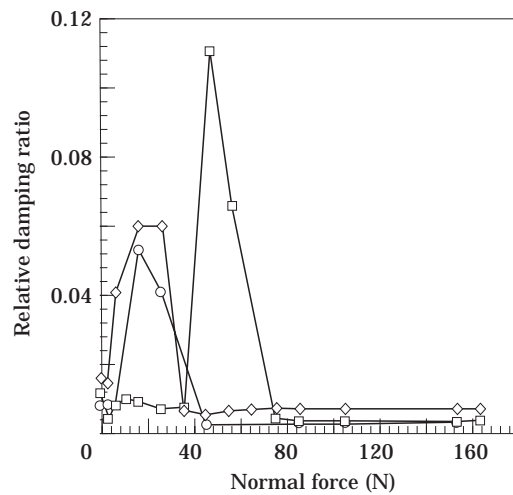

Figure 6. The normal force versus the relative damping ratio of the first mode of the damped blade. Key as for Figure 5.

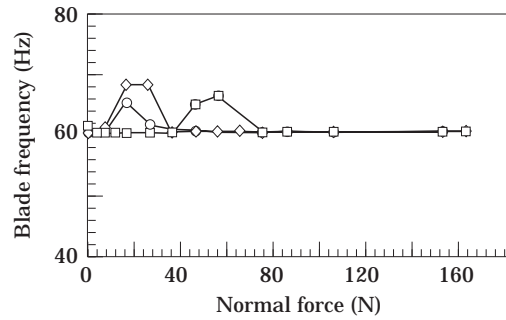

Figure 7. The normal force versus the frequency of the first mode of the damped blade. Key as for Figure 5.

damping effect of the damper is best. When the normal force is smaller than its optimum value, the damping lacing wire and the damped blade will not come into contact with each other, and the relative slip between them is unsteady. In addition, the friction force is small. While the normal force rises, the friction force rises simultaneously, the relative slip motion becomes steadier, and the damping effect is enhanced. If the normal force still increases from its optimum value, the contact between the damper and blade will become very tight. The damper and the blade will have difficulty slipping from each other, and the damping effect of the damper becomes poor. The bigger the normal force is, the more difficult will the slip be between the damper and the blade. When the normal force reaches a limiting value, N_{max} , there is no relative slip motion between the damper and blade, and the damping lacing wire vibrates simultaneously with the blade without a damping effect on the blade.

Figure 5 shows that the optimum normal force varies with the exciting force. The optimum values of normal force are 16 N, 20 N and 45 N corresponding to the exciting force p_1 , p_2 and p_3 , where $p_1 < p_2 < p_3$. If the exciting force decreases, under a certain normal force it becomes difficult for the friction motion to happen so the normal force needs to be decreased to damp the vibration effectively. However, if the exciting force increases, the relative motion between the damper and blade becomes easy to fulfil. It

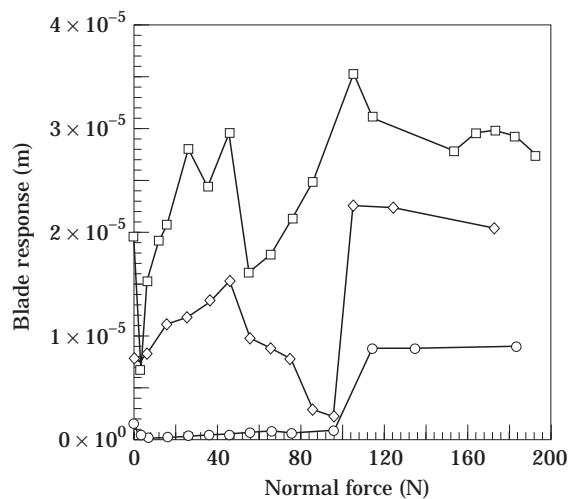

Figure 8. The normal force versus the response of the second mode of the damped blade. Key as for Figure 5.

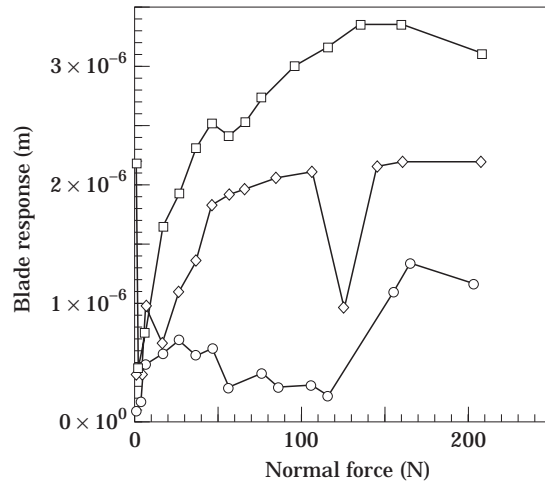

Figure 9. The normal force versus the response of the third mode of the damped blade. Key as for Figure 5.

will have the more effective damping effect on the blade at a higher normal force. The limited force under which the damping lacing wire can vibrate simultaneously with the blade also increases because of the increase of the exciting force.

(3) The diagram of the relation between the relative damping ratio of the first mode and the normal force is depicted in Figure 6. It can be seen that Figure 6 corresponds to Figure 5, and each curve has a tip value which shows that the damper has very good damping effect under the optimum normal force. It can also be seen that the value at the point of the tip moves in the direction in which the normal force increases when the exciting force increases. The value of relative damping ratio of the first mode of the damped blade is in the region of 0.0025–0.12 (shown in Figure 5), which is much higher than that of a free blade 0.001851. Hence the damping effect of the damped blade is obvious. If the normal force is correctly selected during the design of the damped blade, the effect of damping will be more obvious.

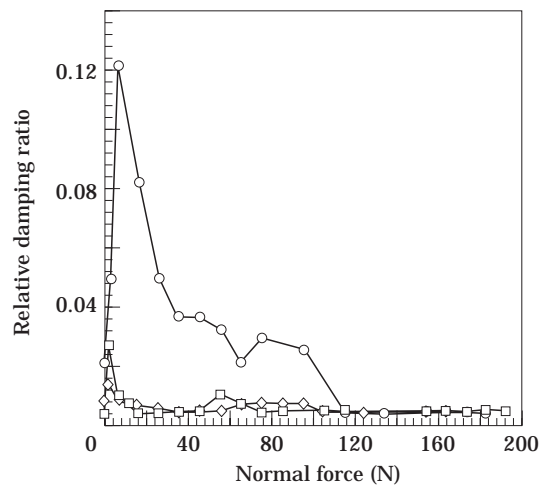

Figure 10. The normal force versus the relative damping ratio of the second mode of the damped blade. Key as for Figure 5.

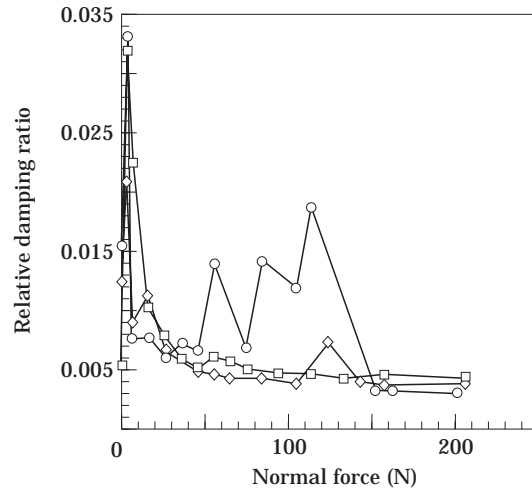

Figure 11. The normal force versus the relative damping ratio of the third mode of the damped blade. Key as for Figure 5.

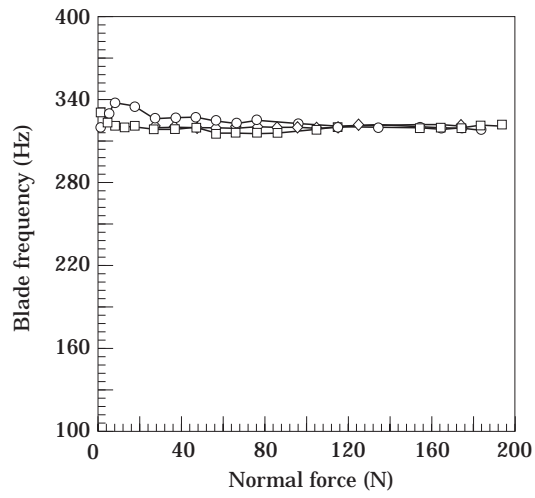

Figure 12. The normal force versus the frequency of the second mode of the damped blade. Key as for Figure 5.

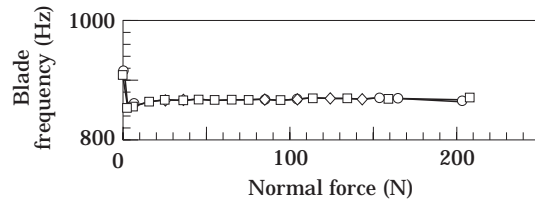

Figure 13. The normal force versus the frequency of the third mode of the damped blade. Key as for Figure 5.

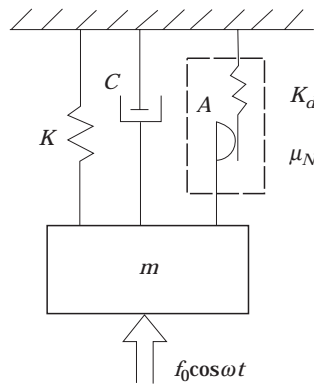

Figure 14. The theoretical model of the damped blade.

(4) The relationship of the normal force versus the frequency of the damped blade is depicted in Figure 7. There is a tip value on each curve corresponding to Figure 5. It means that the blade is restrained severely by the damping lacing wire when the optimum normal force is applied. Since a good damping effect can be acquired at this value, the amplitude of the vibration of the blade is very small, and both the appendant stiffness and damping to the blade are large. If the normal force is less than the optimum normal force, the restraint of the blade by the damper is weaker, and the frequency of the blade is changed slightly. If the normal force is larger, especially larger than N_{max} , the friction force will be so high that the damper could vibrate with the blade simultaneously, and the frequency will not vary although the normal force increases.

(5) Compared with the first mode, the test results of the second and third modes are not as good as those of the first mode. Nevertheless, they express the same relation which has been proven in the first mode. Figures 8 and 9 show the relationships between the normal force and response of the second and the third modes of the blade respectively. From these two figures, it can be seen that some curves which are under a smaller exciting force have the optimum normal force. There is also the optimum normal force at high exciting force. It is not achieved only because the value of the optimum normal force is outside the test region. For the second and the third modes of the vibration, the acceleration of the point at which the exciting force is applied is bigger than that of the first mode, and the exciting force is bigger (refer to the operating principle of the exciter). So in Figures 8 and 9, some curves are undulatory. As the exciting force is larger, the vibration of the damped blade becomes unsteady and the sound of the rubbing and collision is very loud.

(6) Figures 10 and 11 show the relationship of the normal force versus the relative damping ratio of the second and the third modes of the damped blade. It can be seen that the points with high relative damping ratios correspond to the ones with low amplitudes of response. Figure 10 shows that the value of the lowest point is greater than 0.0025, which is greater than the relative damping ratio of the second mode of the free blade, 0.00118382. In Figure 11 the value of the lowest point is greater than 0.0025, which is greater than the relative damping ratio of the third mode of the free blade, 0.0008028.

(7) The curves which show the relation of the normal force and frequency of the second and the third modes of the damped blade are depicted in Figures 12 and 13 respectively. From these figures, it can be seen that the value of the frequency is greater if the relative damping ratio is greater by consulting Figures 10 and 11. Compared with the first mode,

the curves of the second and the third modes are flatter. Through the analysis made above, it can be concluded that all modes of blade vibration will be similarly affected by the normal force and the exciting force.

4. ERROR ANALYSIS

There are always manufacturing errors and design inaccuracy in the real test apparatus. It shows that the test apparatus may not copy exactly the original design. The errors of the test apparatus in this experiment include:

(1) The effect of the mass of the exciter's arm on exciting force: the exciting force is produced by the inertia of a lumped working mass in the exciter. The exciter's arm is an appendant mass to the working mass. If the mass of the exciter's arm is bigger, the operating characteristics of the exciter will be changed, especially when the acceleration of the point where the exciting force is applied is large. It can explain why the test results of the second and the third modes are not very good. The exciter's arm is required to be thin and its longitudinal stiffness is required to be large.

(2) The effect that the mass of the transducer and its leading string has. The mass of the transducer is 35 g, and it vibrates simultaneously with the damped blade as an appendant mass to the blade in the test. Its leading string also vibrates with the blade, and they all increase the mass and decrease the frequency of the blade. Fortunately, the mass of the transducer is smaller than that of the blade, so that its effect which is likely to cause errors will be slight.

(3) The effect that the axial force on the frequency of the blade has. According to beam theory, axial force will increase the frequency of the blade. The range of the normal force is 0–200 N in the test. With the aid of theoretical analyses, it can be seen that the frequency increment of the first mode is less than 0.25 Hz because of axial force, and the frequency increment of the second mode is less than 1 Hz and that of the third mode is less than 2 Hz. These figures indicate that the axial force will not affect the frequency of the blade significantly in the region of the test.

(4) The effect which the tension of the string on the force boundary condition of the damper has. The strings on the two sides of the damping lacing wire are used to apply the normal force. When the displacement from the balance location of the damper is too big, there will be a partial force in the tangential direction which hinders the motion of the damped blade as a force restraint. With this kind of force boundary condition it is difficult to analyse the dynamic characteristics of the damped blade.

(5) The effect that friction has between the damper and the blade stand. The stand of the damper is designed to prevent the damper from losing balance and being blocked. Under normal conditions, there is a gap between the damper and the long hole in the damper stand, and they do not come in contact with each other. However, when the displacement of the damper is too big, the damper may lose its balance and produce friction with the stand.

5. THEORETICAL ANALYSIS OF THE TEST RESULTS

The test results can be analysed by using the mass, damper and spring system depicted in Figure 14, and the damper is presented as a flexible friction element. The motion equation of the system is

$$m\ddot{x} + c\dot{x} + kx = f_0 \cos \omega t - f_N, \quad (2)$$

where $f_0 \cos \omega t$ is the sinusoidal external excitation and f_N is the friction force, which induces a displacement at A of x . The friction force f_N can be expressed as

$$f = \begin{cases} K_d(\Delta u - B) + \mu N & 0 \leq \theta \leq \theta^*, \\ -\mu N & \theta^* \leq \theta \leq \pi, \\ -K_d(\Delta u - B) - \mu N & \pi \leq \theta \leq \theta^* + \pi, \\ \mu N & \theta^* + \pi \leq \theta \leq 2\pi \end{cases}, \quad (3)$$

where:

$$\theta^* = \cos^{-1}(1 - 2\mu N/(K_d B)). \quad (4)$$

It is assumed that the displacement of the damped blade is harmonic, which has been proved by this experiment, and a Fourier expansion of f_N can be expressed with the first two terms

$$f_N = (f_c/B)x + (f_s/B)\dot{x}, \quad (5)$$

where f_c and f_s are the functions of the coefficient of friction μ , the normal force N , the stiffness of damper K_d and the displacement amplitude of blade B . Substituting equation (5) into equation (2) results in

$$m\ddot{x} + (c + f_s/B)\dot{x} + (k + f_c/B)x = f_0 \cos \omega t. \quad (6)$$

It can be seen that the additional terms f_c/B and f_s/B have influence on the frequency, the relative damping ratio and the response of the damped blade, which result in the non-linear characteristics in the damped blade system.

6. CONCLUSION

From the analyses given above, the following conclusions can be drawn, which are suitable not only for the blade with the damping lacing wire, but also for blades with other kinds of dampers.

(1) The damping lacing wire in the test has a good damping effect on the blade. The relative damping ratio of the damped blade is increased obviously because of the dry friction between the damper and the blade, and the amplitude of the vibration of the damped blade can be decreased to a large extent. The resonance frequency of the damped blade shows an increase near the optimum normal force at which the amplitude of the vibration is little and the restraint of the blade motion is severe. However, when out of the optimum region, the resonance frequency remains approximately constant.

(2) There is an optimum normal force acting on the contacting surfaces between the damping lacing wire and the blade. Under the action of this force, the damping effect of the damper is the best. If the normal force is lower than the optimum, the damping effect is weak because the friction force is weak. If the normal force is greater than its optimum value, the contact between the damper and blade becomes so tight that it would be difficult for frictional motion to happen, and the damping effect is also weak in this situation.

(3) The waveform of response of the damped blade is approximately sinusoidal when the sine exciting force is applied. This illustrates that the Harmonic Balance Method used in the theoretical analysis is correct.

(4) The external exciting force can affect the dynamic characteristics of the damped blade, namely the resonance frequency, the response, the relative damping ratio and the optimum normal force. When the exciting force is higher, the friction motion will become unsteady and may escape from between the damper and the blade. The normal force should be increased if steady friction motion is wanted. The contacting state between the damper and the blade can also influence the damping effect of the damper.

(5) The test results are helpful for a damped blade design. For example, when a new kind of damped blade is designed, the optimum normal force is the most important factor which should be determined first. For the blade with the damping lacing wire, the normal force is caused by the centrifugal force of the lacing wire, so the optimum normal force is determined by the damper's position and mass.

ACKNOWLEDGMENTS

The authors wish to thank the National Laboratory of Mechanical Structural Strength and Vibration for its support, and Dr. Changqing Chen, Miss Xiaoyi Jin, Prof. Danzhi Chen and Prof. Maozheng Yu for the revisions.

REFERENCES

1. Z. F. WANG 1985 *Electric Technology* **7**, 8–25. Experimental research on vibration characteristics of blade groups connected by complete rings of loose lacing wires.
2. C.-H. MENQ and J. H. GRIFFIN 1985 *ASME Journal of Vibration, Acoustics, Stress, and Reliability in Design* **107**, 19–25. A comparison of transient and steady state finite element analysis of the forced response of a frictionally damped beam.
3. C.-H. MENQ, J. H. GRIFFIN and J. BIELAK 1986 *ASME Journal of Engineering of Gas Turbine and Power* **108**, 300–305. The influence of a variable normal load on the forced vibration of a frictionally damped structure.
4. A. V. SRINIVASAN and D. G. CUTTS 1983 *ASME Journal of Engineering for Power* **105**, 332–341. Dry friction damping mechanisms in engineering blades.
5. R. KIELB, J. H. GRIFFIN and C.-H. MENQ 1988 *AIAA/ASME/ASCE/AHS/ 29th Structures, Structural Dynamics and Materials Conference*. Evaluation of a turbine blade damper using an integrated approach.