



VIBRATION NODES, AND THE CANCELLATION OF POLES AND ZEROS BY UNIT-RANK MODIFICATIONS TO STRUCTURES

J. E. MOTTERSHEAD

*Department of Engineering, Mechanical Engineering Division, The University of
Liverpool, Liverpool L69 3GH, England*

AND

G. LALLEMENT

*Laboratoire de Mécanique Appliquée, Université de Franche-Comté, Besançon,
France*

(Received 20 July 1998, and in final form 14 December 1998)

The main focus of this paper is on pole-zero cancellation in structures by unit-rank modifications. The modifications may be achieved by passive stiffnesses or by active control techniques. A review of the classical theory on unit-rank modification is included and new results are obtained to explain the existence of coincident zeros in point and cross receptances. The necessary and sufficient conditions are established for the production of a vibration node by pole-zero cancellation. The classical theory is used to bring about the cancellation of poles and zeros, and numerical examples are used to illustrate the application of the technique.

© 1999 Academic Press

1. INTRODUCTION

Resonant vibrations caused by an excitation force at a frequency close to a natural frequency is a common problem in machine design, and in existing machinery which is made to operate at a different frequency (usually faster) than was originally intended. Structural modifications are needed which will shift the troublesome natural frequency away from the driving frequency or change the spatial location of a vibration node.

A common approach is to use the sensitivity method. For example, Kajiwara and Nagamatsu [1] used the sensitivities of the poles (natural frequencies) and zeros (antiresonances) to optimise the design of an optical pick-up for a compact disc player by using pole-zero cancellation. Mottershead [2] studied the relationship between the sensitivity of the zeros and the sensitivities of the natural frequencies and mode-shapes of structural systems. An important drawback of the sensitivity approach is that it is based on a linear truncation of

the Taylor series, and is therefore limited to small modifications. Another factor that should be considered is that the scope for making structural modifications is likely to be limited to a small number of parameters because of physical constraints. Pomazal and Snyder [3] determined the natural frequencies and mode-shapes of a system that had been modified by the addition of a unit-rank matrix. The method, which did not involve linearisation, was attributed to the PhD thesis of Weissenburger [4]. Zhang and Lallement [5] used the same method to separate close modes for model updating [6, 7].

Prescribed dynamical behaviour can be achieved by physical modifications to the structure or by the application of active control techniques (e.g., reference [8]). The Appendix gives a thorough review of the “classical” theory on unit-rank adjustment of structural systems including the cases of modification by a passive spring and an active feedback gain. Further information can be obtained from Lallement and Cogan [9] and Rade [10]. Ram and Blech [11] showed that when a system is modified by adding a stiffness, k^* , and a mass, m^* , at a single co-ordinate then all of the natural frequencies above $\sqrt{(k^*/m^*)}$ will decrease whilst all those below $\sqrt{(k^*/m^*)}$ will increase. This latter result can be considered to be an extension of the monotonicity theorem [12]. Li *et al.* [13, 14] considered local mass and stiffness modifications and obtained eigenvalue equations for two parameters Δm and Δk based on the receptances of the so-called “virtual” system to produce the cancellation of a pole with a zero.

In this paper new results are obtained to explain the existence of coincident zeros in point and cross receptances, and the necessary and sufficient conditions are established for the mutual cancellation of a pole and a zero to form a vibration node. The effects of various unit-rank modifications are investigated, including the modification of a substructure eigenvalue. It is explained how the classical theory on unit-rank modification may be applied to produce a pole-zero cancellation. Numerical examples are given to demonstrate the application of the technique.

2. POLE-ZERO CANCELLATION AND VIBRATION NODES

It is well known [2] that the zeros of the k th point receptance, h_{kk} , of an $n \times n$ system can be determined as the eigenvalues $\bar{\lambda}_i(\mathbf{K}, \mathbf{M})_k$, $i = 1, \dots, n - 1$, where the subscript k on (\mathbf{K}, \mathbf{M}) denotes that the k th row and column have been deleted from the stiffness and mass matrices, $\mathbf{K}, \mathbf{M} \in \mathbb{R}^{n \times n}$, $\mathbf{M} = \mathbf{M}^T > 0$, $\mathbf{K} = \mathbf{K}^T \geq 0$ (or > 0). Generally if a single-degree-of-freedom point mass or a grounded spring is attached at the k th co-ordinate the poles will be changed and the zeros will be unaffected. The study begins by partitioning the stiffness and mass matrices, and without loss of generality the first co-ordinate is separated so that the poles and zeros of the first point receptance are considered. Thus, the system matrices can be written in the form,

$$\mathbf{K} = \begin{bmatrix} k_{11} & | & \bar{\mathbf{k}}^T \\ \hline \bar{\mathbf{k}} & | & \bar{\mathbf{K}} \end{bmatrix}, \quad \mathbf{M} = \begin{bmatrix} m_{11} & | & \bar{\mathbf{m}}^T \\ \hline \bar{\mathbf{m}} & | & \bar{\mathbf{M}} \end{bmatrix}, \quad (1, 2)$$

where

$$\bar{\mathbf{k}}^T = [k_{12}k_{13} \cdots k_{1n}] \in \mathfrak{R}^{1 \times (n-1)}, \tag{3}$$

$$\bar{\mathbf{K}} = \mathbf{K}_1 = \begin{bmatrix} k_{22} & k_{23} & & \\ k_{32} & k_{33} & & \\ & & \ddots & \\ & & & k_{nn} \end{bmatrix} \in \mathfrak{R}^{(n-1) \times (n-1)}, \tag{4}$$

$$\bar{\mathbf{m}}^T = [m_{12}m_{13} \cdots m_{1n}] \in \mathfrak{R}^{1 \times (n-1)}, \tag{5}$$

and

$$\bar{\mathbf{M}} = \mathbf{M}_1 = \begin{bmatrix} m_{22} & m_{23} & & \\ m_{32} & m_{33} & & \\ & & \ddots & \\ & & & m_{nn} \end{bmatrix} \in \mathfrak{R}^{(n-1) \times (n-1)}. \tag{6}$$

The matrices, $\bar{\mathbf{K}}$ and $\bar{\mathbf{M}}$, may be rotated into the system of principal co-ordinates,

$$\Psi^T \bar{\mathbf{K}} \Psi = \text{diag}(\kappa_i), \tag{7}$$

$$\Psi^T \bar{\mathbf{M}} \Psi = \text{diag}(\mu_i), \quad i = 1, \dots, n - 1, \tag{8}$$

where $\Psi \in \mathfrak{R}^{(n-1) \times (n-1)}$ is the matrix of eigenvector columns, and a congruent transformation,

$$\mathbf{A} = \mathbf{R}^T \bar{\mathbf{K}} \mathbf{R}, \quad \mathbf{B} = \mathbf{R}^T \bar{\mathbf{M}} \mathbf{R}, \tag{9, 10}$$

$$\mathbf{R} = \begin{bmatrix} I & | & \\ - & | & - \\ & | & \Psi \end{bmatrix}, \tag{11}$$

leads to

$$\mathbf{A} = \begin{bmatrix} k_{11} & | & \mathbf{a}^T \\ - & | & - \\ \mathbf{a} & | & \text{diag}(\kappa_i) \end{bmatrix}, \tag{12}$$

$$\mathbf{B} = \begin{bmatrix} m_{11} & | & \mathbf{b}^T \\ - & | & - \\ \mathbf{b} & | & \text{diag}(\mu_i) \end{bmatrix}, \tag{13}$$

where,

$$\mathbf{a}^T = \bar{\mathbf{k}}^T \Psi, \quad \mathbf{b}^T = \bar{\mathbf{m}}^T \Psi, \tag{14, 15}$$

and

$$\bar{\lambda}_i(\bar{\mathbf{K}}, \bar{\mathbf{M}}) = \frac{\kappa_i}{\mu_i}. \tag{16}$$

Since the columns of \mathbf{R} are independent it is clear that $\mathbf{B}^{-1}\mathbf{A}$ is similar to $\mathbf{M}^{-1}\mathbf{K}$. The matrices \mathbf{A} and \mathbf{B} are known as *bordered diagonal matrices* [15]. The eigenvalues, $\bar{\lambda}_i$, are the zeros of the point receptance at the chosen first co-ordinate, and the r th pole, λ_r , satisfies the expression,

$$\det(\mathbf{A} - \lambda_r \mathbf{B}) = 0, \quad (17)$$

which leads to

$$(k_{11} - \lambda_r m_{11}) \prod_{i=1}^{n-1} (k_i - \lambda_r \mu_i) - \sum_{j=1}^{n-1} (a_j - \lambda_r b_j)^2 \prod_{\substack{i=1 \\ i \neq j}}^{n-1} (k_i - \lambda_r \mu_i) = 0. \quad (18)$$

One might wonder under what conditions equation (18) can be satisfied and $\lambda_r = \bar{\lambda}_s$. If such a state of affairs can exist then it is clear that the (theoretically) unbounded resonant vibrations at the first co-ordinate will be quelled by the coincidence of the zero $\bar{\lambda}_s$. This is what happens at a vibration node. By expanding equation (18) and using equations (14) and (15) it is found that if $\bar{\lambda}_s$ is distinct then a pole-zero cancellation can only occur when the conditions,

$$(\bar{\mathbf{k}} - \bar{\lambda}_s \bar{\mathbf{m}})^T \bar{\boldsymbol{\psi}}_s = 0, \quad \bar{\lambda}_s = \lambda_r, \quad (19, 20)$$

are both satisfied.

If a pole-zero cancellation in h_{11} is to produce a vibration node then the same cancellation must occur in every cross-receptance that involves the first co-ordinate. To see that this is indeed true consider without loss of generality the cross receptance h_{21} . The zeros are given by $\bar{\lambda}_i(\mathbf{K}, \mathbf{M})_{21}$, corresponding to elimination of the second row and first column of (\mathbf{K}, \mathbf{M}) . Thus,

$$\mathbf{K}_{21} = \begin{bmatrix} k_{12} & k_{13} & k_{14} & \cdots & k_{1,n} \\ k_{32} & k_{33} & k_{34} & \cdots & k_{3,n} \\ k_{42} & k_{43} & k_{44} & \cdots & k_{4,n} \\ \vdots & \vdots & \vdots & & \vdots \\ k_{n,2} & k_{n,3} & k_{n,4} & \cdots & k_{n,n} \end{bmatrix}, \quad (21)$$

and

$$\mathbf{M}_{21} = \begin{bmatrix} m_{12} & m_{13} & m_{14} & \cdots & m_{1,n} \\ m_{32} & m_{33} & m_{34} & \cdots & m_{3,n} \\ m_{42} & m_{43} & m_{44} & \cdots & m_{4,n} \\ \vdots & \vdots & \vdots & & \vdots \\ m_{n,2} & m_{n,3} & m_{n,4} & \cdots & m_{n,n} \end{bmatrix}, \quad (22)$$

The matrices \mathbf{K}_{21} and \mathbf{M}_{21} differ from \mathbf{K}_1 and \mathbf{M}_1 only in the terms above the partition in equations (21) and (22). Thus, if $\bar{\boldsymbol{\psi}}_s$ is an eigenvector of $(\mathbf{K}_1 - \bar{\lambda}_s \mathbf{M}_1)$, and equation (19) holds, then it must also be an eigenvector of $(\mathbf{K}_{21} - \bar{\lambda}_s \mathbf{M}_{21})$.

Clearly $\bar{\lambda}_s$ must be an eigenvalue of both $(\mathbf{K}, \mathbf{M})_1$ and $(\mathbf{K}, \mathbf{M})_{21}$. This means that $\bar{\lambda}_s$ will be a zero of the point receptance h_{11} and of the cross receptance $h_{21} (= h_{12})$. Thus, the desired common zero in the point and cross receptances of the first co-ordinate is assured, but it does not necessarily follow that the zero $\bar{\lambda}_s$ will cancel with the pole λ_r unless their frequencies coincide. So, one can conclude that equation (19) is a sufficient condition and equation (20) is a necessary one. It follows that a vibration node will result from a pole-zero cancellation if and only if both equations (19) and (20) are satisfied.

Separately from the poles there will generally be other zeros $\lambda_s \neq \lambda_r$, which do not give rise to cancellations yet $(\mathbf{k} - \bar{\lambda}_s \bar{\mathbf{m}})^T \boldsymbol{\psi}_s = 0$. It follows that every eigenvalue of $(\mathbf{K}, \mathbf{M})_p$ that satisfies equation (19) (whether or not equation (20) is satisfied) is also an eigenvalue of $(\mathbf{K}, \mathbf{M})_{pq}$, $q = 1, \dots, n$, ($q \neq p$), and when such an eigenvalue (zero) appears in the point receptance it must also appear in all cross receptances of the same co-ordinate.

For the case of a common zero $\bar{\lambda}_s$ in h_{11} and h_{21} it is seen that,

$$\left(\left(\begin{bmatrix} \bar{\mathbf{k}}^T \\ - \quad - \\ \mathbf{K}_1 \end{bmatrix} - \bar{\lambda}_s \begin{bmatrix} \mathbf{m}^T \\ - \quad - \\ \mathbf{M}_1 \end{bmatrix} \right) \boldsymbol{\psi}_s = 0. \quad (23)$$

If $\bar{\lambda}_s = \lambda_r$, then from the eigen-equation of the poles, $(\mathbf{K} - \lambda_r \mathbf{M})\boldsymbol{\varphi}_r = 0$, and equation (23) it is found that,

$$\left(\left\{ \begin{matrix} k_{11} \\ - \quad - \\ \bar{\mathbf{k}} \end{matrix} \right\} - \lambda_r \left\{ \begin{matrix} m_{11} \\ - \quad - \\ \bar{\mathbf{m}} \end{matrix} \right\} \right) \varphi_{1r} = 0. \quad (24)$$

Since

$$\left(\left\{ \begin{matrix} k_{11} \\ - \quad - \\ \bar{\mathbf{k}} \end{matrix} \right\} - \lambda_r \left\{ \begin{matrix} m_{11} \\ - \quad - \\ \bar{\mathbf{m}} \end{matrix} \right\} \right) \neq 0$$

it follows that $\varphi_{1r} = 0$ and $\boldsymbol{\psi}_s = (\varphi_{2r} \varphi_{3r} \dots \varphi_{nr})^T$. This result confirms that the displacement φ_{1r} at a vibration node (the first co-ordinate) of the r th mode is zero.

In the following two sections, the effect of modification by a single-degree-of-freedom point mass or a grounded spring is considered first, and afterwards the attention is turned to more general unit-rank modification problems. The application of the classical unit-rank modification theory to the problem of pole-zero cancellation is considered in section 6.

3. MODIFICATION BY A SINGLE-DEGREE-OF-FREEDOM POINT MASS OR A GROUNDED SPRING

The case of a single-degree-of-freedom point mass, m^* , and a grounded spring, k^* , attached at a single co-ordinate within a multi-degree-of-freedom system will be studied. To adjust the r th natural frequency whilst maintaining the

antiresonances of the first point receptance it is necessary to find the roots of,

$$\det(\mathbf{A}^* - (\lambda_r + \Delta\lambda)\mathbf{B}^*) = 0, \quad (25)$$

where $\Delta\lambda$ is the desired change in the r th eigenvalue, and

$$\mathbf{A}^* = \mathbf{A} + \begin{bmatrix} k^* & | & \\ - & | & - \\ & | & \mathbf{0} \end{bmatrix}, \quad \mathbf{B}^* = \mathbf{B} + \begin{bmatrix} m^* & | & \\ - & | & - \\ & | & \mathbf{0} \end{bmatrix} p. \quad (26, 27)$$

Equation (25) leads to the expression,

$$\begin{aligned} & (k_{11} + k^* - (\lambda_r + \Delta\lambda)(m_{11} + m^*)) \prod_{i=1}^{n-1} (\kappa_i - (\lambda_r + \Delta\lambda)\mu_i) \\ & - \sum_{j=1}^{n-1} (a_j - (\lambda_r + \Delta\lambda)b_j)^2 \prod_{\substack{i=1 \\ i \neq j}}^{n-1} (\kappa_i - (\lambda_r + \Delta\lambda)\mu_i) = 0, \end{aligned} \quad (28)$$

which can be further simplified to give,

$$(k_{11} + k^* - (\lambda_r + \Delta\lambda)(m_{11} + m^*)) = \sum_{j=1}^{n-1} \frac{(a_j - (\lambda_r + \Delta\lambda)b_j)^2}{(\kappa_j - (\lambda_r + \Delta\lambda)\mu_j)}. \quad (29)$$

The dominant right-hand side terms are those where $\lambda_r + \Delta\lambda$ is closest to $\bar{\lambda}_j$. This seems to indicate that a reasonable estimate to the modification (k^* , m^*) can be obtained by truncating the sum on the right-hand side of equation (29). For example, it might be useful to determine the stiffness and mass modifications necessary to produce a 10% change to λ_r . It does not however provide a unique solution since there may be two unknowns (k^* and m^*) to be determined from a single linear equation. First-order sensitivity analysis involves linearisation whereas the use of equation (29) does not.

When $\lambda_r + \Delta\lambda = \bar{\lambda}_s$ it can be seen that equation (28) is satisfied regardless of the values taken by k^* and m^* . The physical meaning of this is that natural frequencies are unchanged by the application of a single-degree-of-freedom point mass or a grounded spring at a vibration node. Thus, it is not possible to determine any solution for k^* or m^* from equation (29) when $\lambda_r + \Delta\lambda = \bar{\lambda}_s$.

4. MODIFICATION BY A SPRING CONNECTING TWO CO-ORDINATES

Here the effect of joining two co-ordinates with a uniaxial spring k^* is considered. The first two co-ordinates may be chosen without any loss of generality, so that the modified stiffness matrix can be written as,

$$\mathbf{K}^* = \mathbf{K} + k^* \begin{bmatrix} 1 & -1 & | & \\ -1 & 1 & | & \mathbf{0} \\ \hline & & | & \mathbf{0} \end{bmatrix}. \quad (30)$$

A transformation can be chosen so that the modification k^* applies to a single co-ordinate as was previously discussed in section 3.

Thus,

$$\begin{Bmatrix} x_1 \\ x_2 \\ x_3 \\ \vdots \\ x_n \end{Bmatrix} = \left[\begin{array}{cc|c} 1/\sqrt{2} & 1/\sqrt{2} & \\ -1/\sqrt{2} & 1/\sqrt{2} & \\ \hline & & \mathbf{I}_{(n-2) \times (n-2)} \end{array} \right] \begin{Bmatrix} (x_1 - x_2)/\sqrt{2} \\ (x_1 + x_2)/\sqrt{2} \\ x_3 \\ \vdots \\ x_n \end{Bmatrix}, \quad (31)$$

leads to

$$\mathbf{T}^T \mathbf{K}^* \mathbf{T} = \mathbf{T}^T \mathbf{K} \mathbf{T} + k^* \begin{bmatrix} 2 & & \\ & & \\ & & \mathbf{0} \end{bmatrix}, \quad (32)$$

where

$$\mathbf{T} = \left[\begin{array}{cc|c} \frac{1}{\sqrt{2}} & \frac{1}{\sqrt{2}} & \\ -\frac{1}{\sqrt{2}} & \frac{1}{\sqrt{2}} & \\ \hline & & \mathbf{I}_{(n-2) \times (n-2)} \end{array} \right], \quad (33)$$

and k^* is applied at the first co-ordinate. The same transformation can be applied to the mass matrix.

It is clear from the analysis in section 3 that the shift in the r th eigenvalue due to the modification k^* is bounded by the eigenvalues $\bar{\lambda}_{r-1}(\bar{\mathbf{K}}, \bar{\mathbf{M}})$ and $\bar{\lambda}_r(\bar{\mathbf{K}}, \bar{\mathbf{M}})$ where,

$$\bar{\mathbf{K}} = \begin{bmatrix} \frac{1}{2}(k_{11} + 2k_{12} + k_{22}) & k_{23} & & & \\ & k_{32} & k_{33} & & \\ & & & \ddots & \\ & & & & k_{nn} \end{bmatrix}, \quad (34)$$

$$\bar{\mathbf{M}} = \begin{bmatrix} \frac{1}{2}(m_{11} + 2m_{12} + m_{22}) & m_{23} & & & \\ & m_{32} & m_{33} & & \\ & & & \ddots & \\ & & & & m_{nn} \end{bmatrix}. \quad (35)$$

5. UNIT-RANK MODIFICATION OF A SUBSTRUCTURE

A substructure stiffness matrix, $\mathbf{k} \in \mathfrak{R}^{m \times m}$, $\mathbf{k} = \mathbf{k}^T$, $\text{rank}(\mathbf{k}) = m - \sigma$, which might be a single finite element or a group of elements, can be decomposed into its own eigenvalues and eigenvectors,

$$\mathbf{k} = \mathbf{P} \begin{bmatrix} \mathbf{0} & \\ & \mathbf{Q} \end{bmatrix} \mathbf{P}^T, \quad (36)$$

where

$$\mathbf{Q} = \text{diag}(q_1, \dots, q_{m-\sigma}) \quad (37)$$

is the matrix of non-zero eigenvalues,

$$\mathbf{P} = [\mathbf{P}_r, \mathbf{P}_s] \in \mathfrak{R}^{m \times m}, \quad (38)$$

$$\mathbf{P}_r \in \mathfrak{R}^{m \times \sigma}, \quad \mathbf{P}_s \in \mathfrak{R}^{m \times (m-\sigma)}, \quad (39, 40)$$

is the orthogonal matrix of eigenvectors ($\mathbf{P}\mathbf{P}^T = \mathbf{I}$) and the subscripts r and s denote rigid-body and strain modes respectively. The adjustment of a single non-zero eigenvalue is considered so that $k^* = q_j$. The idea of adjusting the eigenvalues (and eigenvectors) of a substructure was introduced by Gladwell and Ahmadian [16] with the purpose of updating a finite element model to match measured vibration data. This can be one reason for carrying out a unit rank modification to a finite element model.

The modified stiffness matrix can be written as,

$$\mathbf{K}^* = \mathbf{K} + k^* \begin{bmatrix} \mathbf{p}_{sj}\mathbf{p}_{sj}^T & | & & \\ - & - & | & - & - \\ & & | & & \\ & & | & & \mathbf{0} \end{bmatrix}. \quad (41)$$

If \mathbf{P} is rearranged so that \mathbf{p}_{sj} occupies the first column, then (since \mathbf{P} is orthogonal) it is clear that the transformation,

$$\mathbf{T} = \begin{bmatrix} \mathbf{P} & | & & & \\ - & - & | & - & - & - & - \\ & & | & & & & \\ & & | & & & & \mathbf{I}_{(n-m) \times (n-m)} \end{bmatrix} \quad (42)$$

will lead to an equation of the same form as equation (32). Then the determination of the zeros which bound the eigenvalues $\lambda_r + \Delta\lambda$ of the modified system exactly follows the procedures of the previous analysis.

6. APPLICATION OF THE CLASSICAL THEORY

Consider the eigenvalues $\lambda_i(\mathbf{K}, \mathbf{M})$ and eigenvectors $\boldsymbol{\varphi}_i$ of the unmodified system and arrange them as,

$$\boldsymbol{\Lambda} = \text{diag}(\lambda_i), \quad \lambda_1 \leq \lambda_2 \leq \dots \leq \lambda_n, \quad (43)$$

and

$$\boldsymbol{\Phi} = [\boldsymbol{\varphi}_1, \dots, \boldsymbol{\varphi}_n] \in \mathfrak{R}^{n \times n}, \quad (44)$$

where

$$\Phi^T \mathbf{M} \Phi = \mathbf{I}_{n \times n}. \tag{45}$$

If a passive spring k^* connects the co-ordinates f and g , then the eigenproblem of the modified structure can be written as,

$$(\Lambda + k^* \mathbf{z} \mathbf{z}^T) \Phi^T \mathbf{M} \Phi_r^* = (\lambda_r + \Delta\lambda) \Phi^T \mathbf{M} \Phi_r^*, \tag{46}$$

where

$$\mathbf{z} = \left\{ \begin{array}{c} \varphi_{f1} - \varphi_{g1} \\ \varphi_{f2} - \varphi_{g2} \\ \vdots \\ \varphi_{f,n} - \varphi_{g,n} \end{array} \right\}. \tag{47}$$

It can be seen that if the h th element of \mathbf{z} is zero, then at the h th mode a spring connecting f and g will be unstretched and λ_h will remain unchanged by the modification.

For the more general case of a modification to the j th non-zero eigenvalue of a substructure stiffness matrix it is found that,

$$\mathbf{z}_h = \tilde{\Phi}_h^T \mathbf{p}_{sj}, \tag{48}$$

where $\tilde{\Phi}_h$ contains selected terms from Φ_h at each of the substructure co-ordinates. If $z_h = 0$ then $\tilde{\Phi}_h \perp \mathbf{p}_{sj}$ so that (as with the simple two-co-ordinate spring) the eigenvalue λ_h remains unaltered.

In their book *Matrix Computations* (pp. 461–464), Golub and Van Loan [17] consider the problem of diagonalising a matrix of the form diagonal + rank-one, which is exactly the form of the matrix. $(\Lambda + k^* \mathbf{z} \mathbf{z}^T)$ in equation (46). It is shown in reference [17] that the modified eigenvalues are given by the zeros of the function,

$$f(\lambda + \Delta\lambda) = 1 + k^* \mathbf{z}^T (\Lambda - (\lambda + \Delta\lambda) \mathbf{I})^{-1} \mathbf{z}, \tag{49}$$

when \mathbf{z} contains no zero terms. Pomazal and Snyder [3] and Zhang and Lallement [5] obtain an equivalent expression, which is derived in Case (c) of the Appendix, and can be written in the form,

$$\frac{1}{k^*} = - \sum_{i=1}^n \frac{z_i^2}{\lambda_i - (\lambda_r + \Delta\lambda)}. \tag{50}$$

The physical interpretation of a zero term in \mathbf{z} has been explained above, and is given further consideration in references [3, 5]. If a particular term $z_h = 0$ then λ_h will not be changed by the modification, and in that case the h th term may be omitted from the right-hand side of equation (50), the roots of which will be the remaining $(n - 1)$ eigenvalues of the modified system. The case of an active feedback gain between co-ordinates f and g is considered in the Appendix (Case (b)).

A similar expression to equation (50) can be written for the modification that is required to assign the s th zero of the p, q th frequency response h_{pq} , to $\bar{\lambda}_s + \Delta\bar{\lambda}$ and is derived in Case (d) of the Appendix. Thus, for the passive two-co-ordinate spring,

$$\frac{1}{k^*} = - \sum_{i=1}^{n-1} \frac{v_i w_i}{\bar{\lambda}_i - (\lambda_s + \Delta\bar{\lambda})}, \quad (51)$$

where,

$$\mathbf{v} = \begin{Bmatrix} \xi_{f1} - \xi_{g1} \\ \xi_{f2} - \xi_{g2} \\ \vdots \\ \xi_{f,n-1} - \xi_{g,n-1} \end{Bmatrix}, \quad \mathbf{w} = \begin{Bmatrix} \psi_{f1} - \psi_{g1} \\ \psi_{f2} - \psi_{g2} \\ \vdots \\ \psi_{f,n-1} - \psi_{g,n-1} \end{Bmatrix}, \quad (52, 53)$$

and $\boldsymbol{\psi}_i$ and $\boldsymbol{\xi}_i$ are the right- and left-eigenvectors for the i th eigenvalue, $\bar{\lambda}_i$, of the asymmetric system $(\bar{\mathbf{K}}, \bar{\mathbf{M}}) = (\mathbf{K}, \mathbf{M})_{pq}$. The simplification for the point receptance, $p = q$, is straightforward.

Our objective is to modify the system so that the r th pole is cancelled by the s th zero. If a connection can be found whereby either $v_s = 0$ or $w_s = 0$ (or both) then k^* will not change the frequency of the zero $\bar{\lambda}_s$. The unwanted resonance λ_r can then be shifted to coincide with the fixed $\bar{\lambda}_s$ by using equation (50). Alternatively λ_r can be fixed by selecting a connection for k^* that gives $z_r = 0$ and the zero $\bar{\lambda}_s$ can be shifted to cancel λ_r by invoking equation (51). There can be a problem with the application of this latter approach when shifting the zeros of a cross receptance since the interlacing property of the eigenvalues does not extend to unsymmetric matrices the eigenvalues $\bar{\lambda}_i$ may become complex or disappear to infinity. Equation (51) fails in such cases.

When a connection cannot be found to give any zero terms in v or w , or $z_r = 0$, then an iterative approach must be used. The procedure is to choose at each step a connection that results in a small value of the product $v_s w_s$ whilst maximizing z_r^2 . This will result in a rapid convergence of λ_r on $\bar{\lambda}_s$ because the movement of the latter is restricted by the small $v_s w_s$. The large value of z_r^2 will ensure that the convergence is achieved at the cost of a small modification k^* .

7. NUMERICAL EXAMPLES

Two example problems are studied.

7.1. SIX-DEGREE-OF-FREEDOM MASS-SPRING SYSTEM

The system is shown in Figure 1 where all the stiffness and mass values are unity. The natural frequencies and the frequencies of the zeros for the h_{34} cross receptance are given in Table 1. The point receptance h_{33} and the cross receptance h_{34} are plotted in Figure 2. The point receptance is given by the full line and the dashed line describes the cross receptance. It is noticeable immediately that the 2nd and 4th zeros of the point receptance are also zeros on

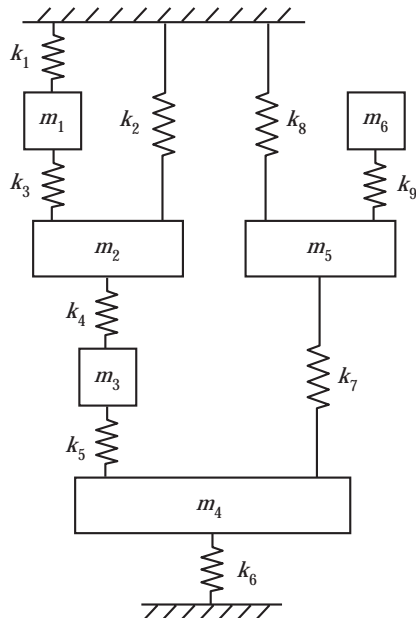

Figure 1. Six-degree-of-freedom mass-spring system.

the curve of the cross receptance. They already satisfy the sufficient condition $(\bar{\mathbf{k}} - \lambda_s \bar{\mathbf{m}}) \perp \boldsymbol{\Psi}_s$, so it only remains to adjust λ_r until the necessary condition $\bar{\lambda}_s = \lambda_r + \Delta\lambda$ is met. The aim is to cancel the 4th natural frequency by shifting it to coincide with the 4th zero. The vectors \mathbf{v} and \mathbf{w} have 4th terms which conveniently disappear to zero when the connection $(f, g) = (4, 6)$ is chosen in equations (52) and (53). Therefore, the preferred modification is a spring k^* between m_4 and m_6 . The 4th zero will not be affected by the introduction of k^* which can be determined in one application of equation (50) without iteration ($k^* = 1.118$). The modified natural frequencies and zero frequencies are given in Table 2, and the modified receptances are plotted in Figure 3. The modified point receptance now shows only five peaks and four zeros because of the cancellation and a vibration node appears at m_3 . The natural frequency at

TABLE 1
Frequencies of poles and zeros before modification

Frequency (rad/s)	
Pole	Zero
0.68	<0
0.91	0.77
1.29	1.18
1.64	1.85
1.97	1.90
2.12	

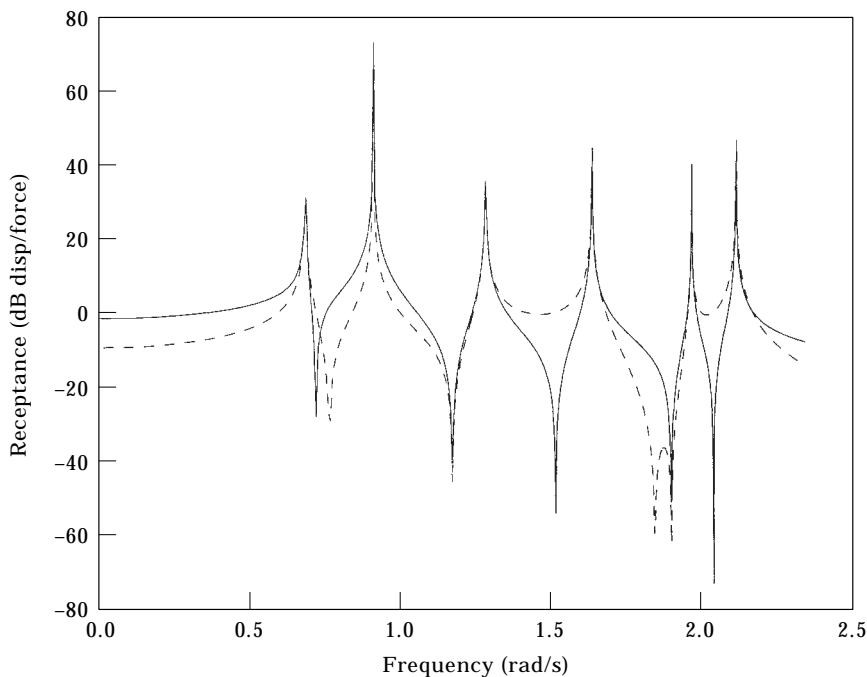

Figure 2. Receptances $|h_3|$ and $|h_{34}|$ before modification (full line, $|h_{33}|$; dashed line, $|h_{34}|$).

1.64 rad/s has disappeared and there is now a natural frequency at 1.90 rad/s to cancel with the zero at the same frequency. There is a new zero at 1.88 rad/s close to the frequency of the cancelled pole and zero.

7.2. TEN-DEGREE-OF-FREEDOM FINITE ELEMENT BEAM

The beam with hinged ends is shown in Figure 4. Its rigidity is $60 \times 10^3 \text{ Nm}^2$ and its mass per unit length is 1200 kg/m. Each element is 1 m long. The natural frequencies of the beam and the zeros of the frequency response h_{24} are given in

TABLE 2
*Frequencies of poles and zeros
after modification*

Frequency (rad/s)	
Pole	Zero
0.74	<0
1.05	1.18
1.39	1.30
1.90	1.88
1.98	1.90
2.27	

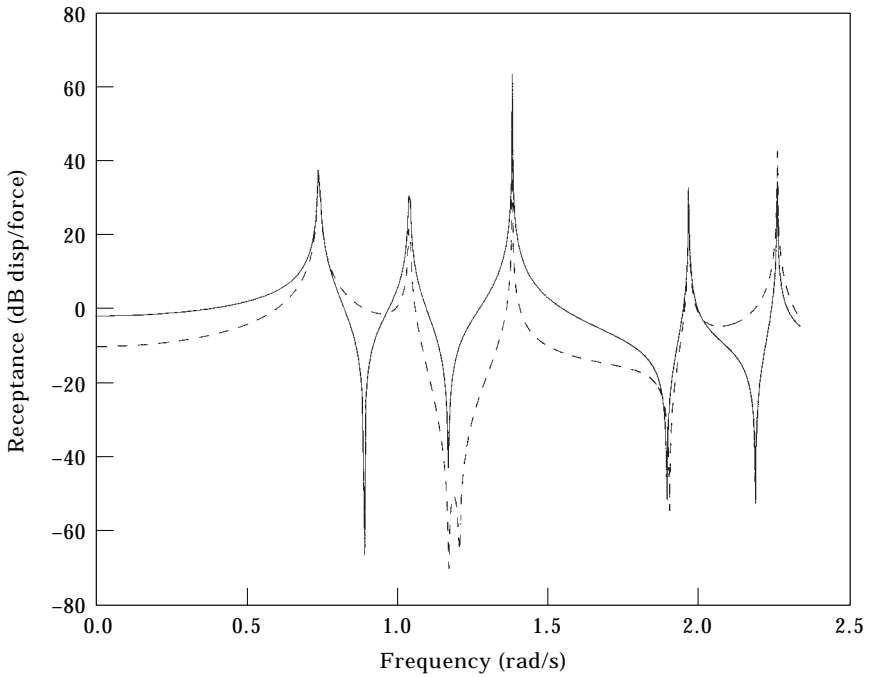

Figure 3. Receptances $|h_{33}|$ and $|h_{34}|$ after modification (full line, $|h_{33}|$, dashed line, $|h_{34}|$).

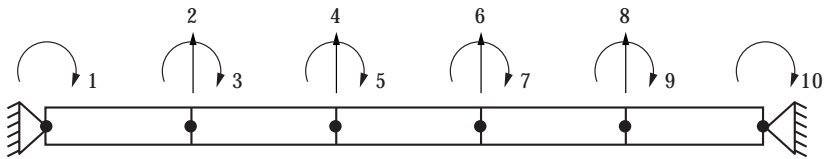

Figure 4. Ten-degree-of-freedom finite element beam.

TABLE 3
Frequencies of poles and zeros before modification

Frequency (rad/s)	
Pole	Zero
2.74	8.03
10.48	25.61
21.89	46.51
35.29	48.99
48.99	68.23
61.51	84.85
71.76	86.35
79.13	∞
84.85	

TABLE 4
Table of eigenvectors

	φ_6	ψ_5	ζ_5
1	-0.5256	-0.3471	0.0707
2	0.0676	-0.0337	-
3	0.4252	0	-0.0043
4	-0.1093	-	0.1409
5	-0.1624	0.6983	0.3525
6	0.1093	-1.3092	-0.1086
7	-0.1624	-0.3023	-0.3642
8	-0.0676	1.2424	0.1145
9	0.4252	-0.3512	-0.3878
10	-0.5256	0.3360	0.7368

Table 3. The eigenvectors corresponding to the 6th natural frequency and the 5th zero are shown in Table 4.

The first bending eigenvector of an individual element stiffness matrix can be shown to be,

$$\left(0 \quad \frac{1}{\sqrt{2}} \quad 0 \quad \frac{-1}{\sqrt{2}}\right)^T.$$

It can be seen from equation (48) that the selection of co-ordinates 7 and 9 for the modification $k^* = q_1$ will lead to strong shifts in λ_6 whilst $\bar{\lambda}_5$ will be constrained by the small values of v_5 and w_5 . The convergence of λ_6 on $\bar{\lambda}_5$ is

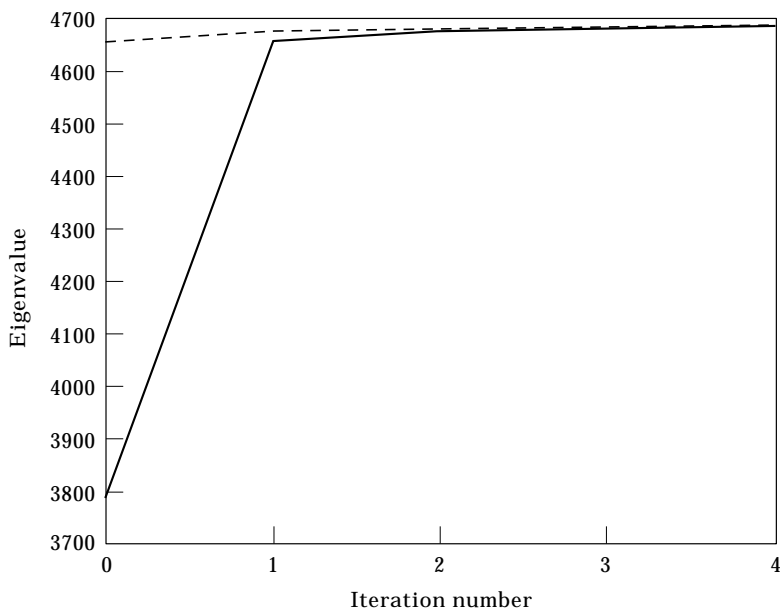

Figure 5. Convergence of λ_6 on $\bar{\lambda}_5$.

TABLE 5
*Frequencies of poles and zeros
 after modification*

Frequency (rad/s)	
Pole	Zero
3·16	10·77
12·85	25·63
22·41	47·47
37·27	67·41
56·85	68·42
68·41	84·85
73·37	86·19
82·75	105·56
84·85	∞
104·95	

shown in Figure 5 to be almost complete after four iterations of equation (50). This results in a vibration node at the 4th degree of freedom. The natural frequencies and zero frequencies upon completion of four iterations are given in Table 5, whereupon the modification is $k^* = 3\cdot41 \times 10^5$ Nm.

8. CONCLUSIONS

1. Every zero of the point receptance h_{ii} that satisfies $(\bar{\mathbf{k}} - \bar{\lambda}_s \bar{\mathbf{m}}) \perp \Psi_s$ must also be a zero of the cross receptances $h_{ij} = h_{ji}$ ($j = 1, \dots, n$, ($j \neq i$)). In general there will be zeros of the point receptances which do not appear in the cross receptances and vice versa.

2. The mutual cancellation of a pole, λ_r , and a zero, $\bar{\lambda}_s$ will result in a vibration node if and only if $(\bar{\mathbf{k}} - \lambda_r \bar{\mathbf{m}}) \perp \Psi_s$.

3. If $\bar{\lambda}_s$ is distinct then a vibration node will be produced whenever $\lambda_r = \bar{\lambda}_s$.

4. The classical theory of unit-rank structural modification can be applied to shift either a pole or a zero, and to bring about a pole-zero cancellation.

5. It is not possible to produce a pole-zero cancellation by a point modification at the same co-ordinate.

REFERENCES

1. I. KAJIWARA and A. NAGAMATSU 1993 *Transactions ASME, Journal of Vibration and Acoustics* **115**, 377–383. Optimum design of optical pick-up by elimination of resonance peaks.
2. J. E. MOTTERSHEAD 1998 *Mechanical Systems and Signal Processing* **12**, 591–598. On the zeros of structural frequency response functions and their sensitivities.
3. R. J. POMAZAL and V. C. SNYDER 1971 *American Institute of Aeronautics and Astronautics Journal* **9**, 2216–2221. Local modifications of damped linear systems.

4. J. T. WEISSENBURGER 1966 *PhD thesis, Washington University*. The effect of local modifications on the eigenvalues and eigenvectors of linear systems.
5. Q. ZHANG and G. LALLEMENT 1989 *Mechanical Systems and Signal Processing* **3**, 55–69. Selective structural modifications: applications to the problems of eigen-solution sensitivity and model adjustment.
6. J. E. MOTTERSHEAD and M. I. FRISWELL 1993 *Journal of Sound and Vibration* **162**, 347–375. Model updating in structural dynamics: a survey.
7. M. I. FRISWELL and J. E. MOTTERSHEAD 1995 *Finite Element Model Updating in Structural Dynamics*. Dordrecht: Kluwer Academic Publishers.
8. I. KAJIWARA and A. NAGAMATSU 1991 *ASME, DE-Vol* **38**, 179–184. An approach to simultaneous optimum design of structure and control systems by sensitivity analysis.
9. G. LALLEMENT and S. COGAN 1998, *NATO Advanced Study Institute, Sesimbra, Portugal*. Parametric identification based on pseudo-tests.
10. D. A. RADE 1994, *PhD thesis, Université de Franche-Comté*. Parametric correction of finite element models: enlargement of the knowledge space (in French).
11. Y. M. RAM and J. J. BLECH 1991 *Journal of Sound and Vibration* **150**, 357–370. The dynamic behaviour of a vibrating system after modification.
12. B. N. PARLETT 1980 *The Symmetric Eigenvalue Problem*. Englewood Cliffs, NJ: Prentice-Hall.
13. Y. LI, J. HE and G. LLEONART 1993 *Asia-Pacific Vibration Conference, Kitakyushu*, 1300–1306. Relocation of resonances and anti-resonances via local structural modifications.
14. Y. LI, J. HE and G. LLEONART 1994 *International Mechanical Engineering Congress, Perth, Western Australia*, 157–161. Finite element implementation of structural dynamic modifications.
15. J. H. WILKINSON 1965 *The Algebraic Eigenvalue Problem*. Oxford: Clarendon Press.
16. G. M. L. GLADWELL and H. AHMADIAN 1995 *Mechanical Systems and Signal Processing* **9**, 601–614. Generic element matrices suitable for finite element model updating.
17. G. H. GOLUB and C. F. VAN LOAN 1989 *Matrix Computations*. Baltimore and London: The John Hopkins University Press.

APPENDIX—REVIEW OF THE CLASSICAL THEORY ON UNIT-RANK MODIFICATION

Case (a): Modification by a grounded passive spring

A passive spring, k^* , connected at co-ordinate f is considered. The eigenvalue equation for the modified system can be written as,

$$[\mathbf{K} + k^* \mathbf{e}_f \mathbf{e}_f^T - \lambda_r^* \mathbf{M}] \boldsymbol{\varphi}_r^* = 0, \quad r = 1, \dots, n, \quad (\text{A1})$$

where

$$\lambda_r^* = \lambda_r + \Delta \lambda, \quad (\text{A2})$$

and \mathbf{e}_f is the f th column of $\mathbf{I}_{n \times n}$. When equation (A1) is premultiplied by $\mathbf{H}(\lambda_r^*) = (\mathbf{K} - \lambda_r^* \mathbf{M})^{-1}$ it is found that,

$$[\mathbf{I} + k^* \mathbf{H}(\lambda_r^*) \mathbf{e}_f \mathbf{e}_f^T] \boldsymbol{\varphi}_r^* = 0, \quad (\text{A3})$$

the f th term of which is given by,

$$(1 + \mathbf{e}_f^T k^* \mathbf{H}(\lambda_r^*) \mathbf{e}_g) \mathbf{e}_f^T \boldsymbol{\varphi}_r^* = 0. \tag{A4}$$

Since $\mathbf{e}_f^T \boldsymbol{\varphi}_r^* \neq 0$, it can be seen that,

$$-\frac{1}{k^*} = h_{ff}(\lambda_r^*), \tag{A5}$$

so $\lambda_r^* \rightarrow \bar{\lambda}_r$ when $k^* \rightarrow \infty$. This leads to the classical interlacing condition,

$$\lambda_r \leq \lambda_r^* \leq \lambda_{r+1}. \tag{A6}$$

Case(b): Modification by an active feedback gain between co-ordinates f and g

Consider the active feedback gain k^* as shown in Figure 6. The modified eigenvalue equation can be written as,

$$[\mathbf{K} + k^* \mathbf{e}_g \mathbf{e}_f^T - \lambda_r^* \mathbf{M}] \boldsymbol{\varphi}_r^* = 0. \tag{A7}$$

Premultiplication by $\mathbf{H}(\lambda_r^*)$ gives,

$$[\mathbf{I} + k^* \mathbf{H}(\lambda_r^*) \mathbf{e}_g \mathbf{e}_f^T] \boldsymbol{\varphi}_r^* = 0, \tag{A8}$$

and from the f th term,

$$(1 + \mathbf{e}_f^T k^* \mathbf{H}(\lambda_r^*) \mathbf{e}_g) \mathbf{e}_f^T \boldsymbol{\varphi}_r^* = 0. \tag{A9}$$

Since $\mathbf{e}_f^T \boldsymbol{\varphi}_r^* \neq 0$ it is found that,

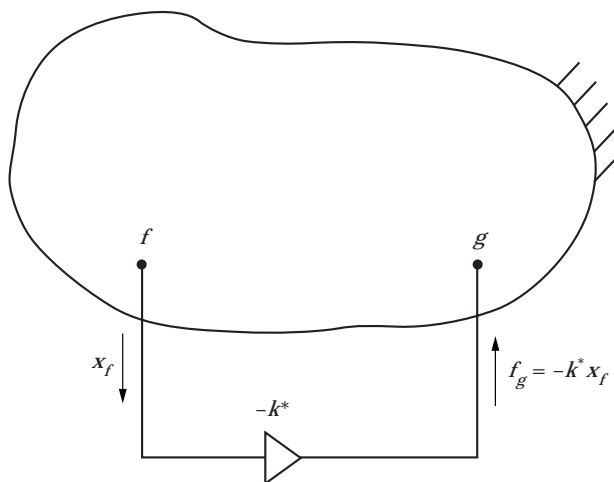

Figure 6. Active feedback gain k^* between co-ordinates f and g .

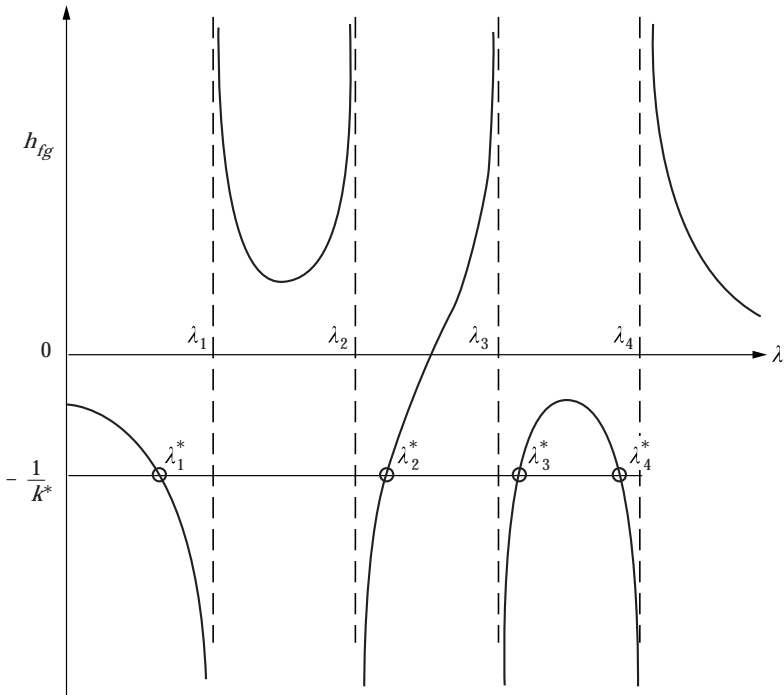

Figure 7. Cross receptance h_{fg} for the interpretation of equation (A10).

$$-\frac{1}{k^*} = h_{fg}(\lambda_r^*). \quad (\text{A10})$$

This result is best interpreted graphically from Figure 7, where it can be seen that there may be 0, 1 or 2 eigenvalues λ_r^* between successive eigenvalues of the original (unmodified) system.

Also, since

$$\mathbf{H}(\lambda_r^*) = \mathbf{\Phi} \text{diag} \left(\frac{1}{\lambda_i - \lambda_r^*} \right) \mathbf{\Phi}^T, \quad i = 1, \dots, n, \quad (\text{A11})$$

it is seen from equation (A10) that

$$-\frac{l}{k^*} = \sum_{i=1}^n \frac{\varphi_{fi} \varphi_{gi}}{(\lambda_i - \lambda_r^*)}. \quad (\text{A12})$$

Case(c): Modification by a passive spring between co-ordinates f and g

The eigenvalue equation for the modified system can be written in the same form as equation (A1) by using the transformation,

$$\mathbf{T} = \left[\mathbf{e}_1 \mathbf{e}_2 \cdots \mathbf{e}_{f-1} \frac{(\mathbf{e}_f - \mathbf{e}_g)}{\sqrt{2}} \mathbf{e}_{f+1} \cdots \mathbf{e}_{g-1} \frac{(\mathbf{e}_f + \mathbf{e}_g)}{\sqrt{2}} \mathbf{e}_{g+1} \cdots \mathbf{e}_n \right]. \tag{A13}$$

The resulting eigenvalue equation can be written as,

$$[\mathbf{T}^T \mathbf{K} \mathbf{T} + 2k^* \mathbf{e}_j \mathbf{e}_f^T - \lambda_r \mathbf{T}^T \mathbf{M} \mathbf{T}] \mathbf{T}^T \boldsymbol{\phi}_r^* = 0, \tag{A14}$$

and the f th point receptance in the rotated co-ordinates will be

$$\frac{(\mathbf{e}_f - \mathbf{e}_g^T)}{\sqrt{2}} \mathbf{H}(\lambda_r^*) \frac{(\mathbf{e}_f - \mathbf{e}_g)}{\sqrt{2}} = \frac{1}{2} \sum_{i=1}^n \frac{(\boldsymbol{\phi}_{fi} - \boldsymbol{\phi}_{gi})^2}{\lambda_i - \lambda_r^*}. \tag{A15}$$

So by comparison with equation (A5) it is seen that,

$$-\frac{1}{k^*} = \sum_{i=1}^n \frac{(\varphi_{fi} - \varphi_{gi})^2}{(\lambda_i - \lambda_r^*)}. \tag{A16}$$

Case(d): Modification of an asymmetric system by a passive spring between co-ordinates f and g

The right and left eigenvectors of the asymmetric system $(\bar{\mathbf{K}}, \bar{\mathbf{M}})$ can be assembled as $\boldsymbol{\Psi} = [\boldsymbol{\psi}_1, \boldsymbol{\psi}_2, \dots, \boldsymbol{\psi}_n]$ and $\mathbf{Z} = [\boldsymbol{\xi}_1, \boldsymbol{\xi}_2, \dots, \boldsymbol{\xi}_n]$ respectively so that the frequency response $\bar{\mathbf{H}}(\bar{\lambda}_s^*)$ can be written in the form,

$$\bar{\mathbf{H}}(\bar{\lambda}_s^*) = [\bar{\mathbf{K}} - \bar{\lambda}_s^* \bar{\mathbf{M}}]^{-1} = \boldsymbol{\Psi} \text{diag} \left(\frac{1}{\bar{\lambda}_i - \bar{\lambda}_s^*} \right) \mathbf{Z}^T, \quad i = 1, \dots, n, \tag{A17}$$

where

$$\bar{\lambda}_s^* = \bar{\lambda}_s + \Delta \bar{\lambda}. \tag{A18}$$

If the transformation given in equation (A13) is applied and the same procedure is followed as in Case (c) then it is found that,

$$-\frac{1}{k^*} = \sum_{i=1}^{n-1} \frac{(\zeta_{fi} - \zeta_{gi})(\psi_{fi} - \psi_{gi})}{\bar{\lambda}_i - \bar{\lambda}_s^*}. \tag{A19}$$