



NON-LINEAR VIBRATION OF CABLE-DAMPER SYSTEMS PART II: APPLICATION AND VERIFICATION

Y. L. XU

*Department of Civil and Structural Engineering, The Hong Kong Polytechnic University,
Hung Hom, Kowloon, Hong Kong*

AND

Z. YU

Department of Mechanical Engineering, University of Michigan-Dearborn, MI, U.S.A.

(Received 20 August 1998, and in final form 15 January 1999)

The formulation derived in Part I of this paper is applied to investigate non-linear vibration behavior of inclined sag cables with and without oil dampers in long-span cable-stayed bridges. The inclined sag cables used in computation are also tested in the laboratory with scaled cables and oil dampers. The experimental results are then compared with the theoretical results to verify the suggested approach. Both theoretical analyses and experiments display some typical non-linear behavior of cable vibration, including response hardening, response bifurcation, multiple solutions, jump, and internal resonance. They also demonstrate that an oil damper with an appropriate damping coefficient being selected can effectively suppress large vibration amplitudes of the cable so that in some cases, non-linear cable vibration problem may become a linear vibration problem. The agreement between the experimental and theoretical results is found to be satisfactory.

© 1999 Academic Press

1. INTRODUCTION

Long and low damped stay cables in modern cable-stayed bridges are prone to large vibrations due to wind excitation, rain-wind excitation, or support motion. Cables of large vibration amplitudes may exhibit strong non-linear dynamic behavior, such as jump, multiple solutions, limit circle, natural-frequency shift, sub- or super-harmonic resonance, hardening or softening response, bifurcation, or chaotic motion. Non-linear vibration response of a cable may also demonstrate abundant internal resonances between in-plane and out-of-plane modes of vibration. One-to-one internal resonance has been found in a taut string of cubic non-linearity [1–5], in which the string subject to harmonic in-plane excitation experiences non-planar motion, that is, the so-called whirling or ballooning motion.

For a long sag cable, both the quadratic and cubic non-linearities arising from the non-linear relationship between the dynamic tension and displacement may

leads to much more complex non-linear behavior and internal resonance than those observed in a taut string. An important cable sag parameter λ^2 was thus introduced by Irvine [6]. This parameter is defined as the ratio of the elastic-to-catenary stiffness. For an inclined sag cable, it can be expressed approximately as

$$\lambda^2 = \left(\frac{mgL}{H} \cos \theta \right)^2 \frac{LEA}{L_e H}, \quad (1)$$

where

$$L_e = L_r \left[1 + \left(\frac{mgL}{H} \cos \theta \right)^2 / 8 \right] \quad (2)$$

L_e is the distance between two supports of the cable in the x_1 -direction (see Figure 1 in Part I), m is the mass of the cable per unit length, g is the acceleration due to gravity, H is the horizontal component of the static tension in the x - y plane, L is the horizontal length between two cable end-supports in the x - y plane, E is the cable modulus of elasticity, A is the cross-sectional area of the cable, and the cable inclination θ is defined as

$$\theta = \arccos \frac{L}{L_r}. \quad (3)$$

To seek possible internal resonances in a long sag cable, most previous studies [7–10] focus on a horizontal cable with a sag parameter $\log \lambda^2$ about 1.6 near the first frequency crossover. Under either external or parametric excitation, the non-linear response of such a sag cable may exhibit one-to-one, two-to-one, two-to-two-to-one or combined internal resonances. The sag parameter, $\log \lambda^2$, of the stay cables in a cable-stayed bridge ranges mostly from -2 to 1 . These stay cables are thus between the taut string and the long sag cable. Their non-linear behavior and internal resonance have not been extensively studied. In particular, the effects of oil damper installed to a bridge stay cable on non-linear behavior and internal resonance have not been discussed yet to be the best of the writers' knowledge. Part II of this paper therefore aims to investigate non-linear vibration behavior of bridge stay cables with and without oil dampers using the approach suggested in Part I of this paper, and to verify this approach through a comparison with experimental results.

2. CABLE-OIL DAMPER SYSTEM

To verify the suggested approach and to study non-linear vibration and vibration mitigation of inclined sag cables with and without oil dampers, a testing facility was developed, as schematically shown in Figure 1, and a series of laboratory tests were carried out on a scaled cable and oil damper. The properties of the test cable are as follows: the cable length is 3.2 m; the cable mass per unit is 0.03682 kg/m; the cross-sectional area A is $4.2614 \times 10^{-6} \text{ m}^2$; the Young's modulus E is $6.814 \times 10^{10} \text{ N/m}^2$; the cable inclination θ is 27.5° ; the cable static tension T is 130 N; and the cable sag parameter $\log \lambda^2$ is -0.84 . These properties of the test

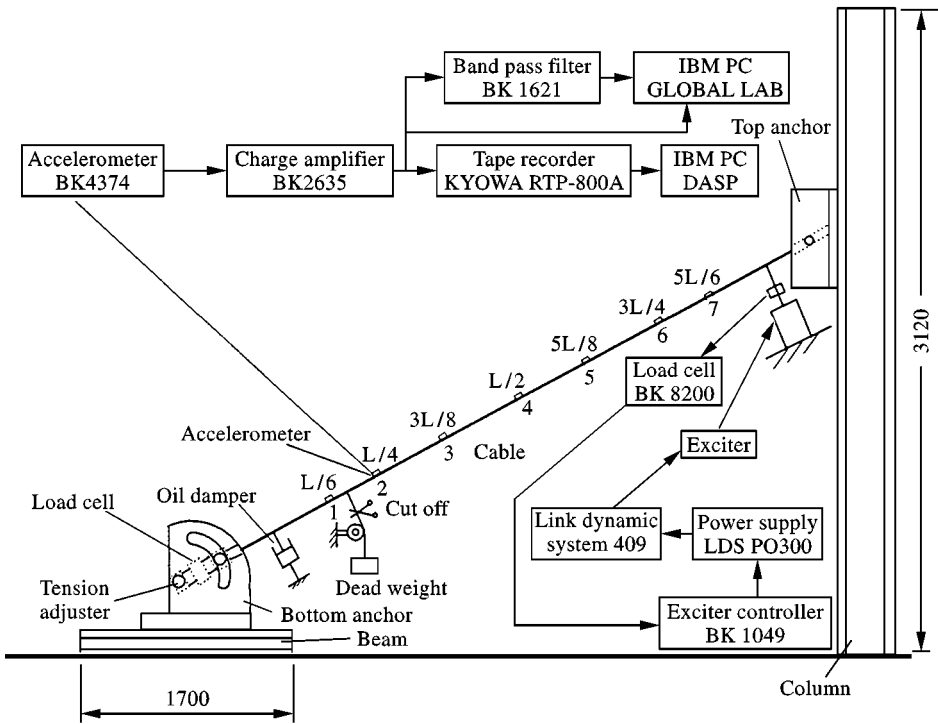

Figure 1. Schematic diagram of testing facility and cable.

cable are selected based on dynamic similarities with actual bridge stay cables. To study the effects of cable sag, the sag parameter of the cable is changed in terms of the change of the cable static tension. An oil damper is installed in the plane of cable static equilibrium normal to the cable length at the location of $3\% L$ measured from the low cable support. In most cases, an optimal damper size obtained from free-vibration tests of the linear cable-damper system is used for the study of the non-linear cable-oil damper system. The free-vibration tests were carried out by hanging a dead weight on the cable using a fishing line and then cutting the fishing line to give the cable an initial displacement. The external dynamic loading is a harmonic concentrated force normally acting on the cable in the cable static equilibrium plane, located at 0.5% cable length measured from the top support of the cable.

To facilitate the discussion of, and comparison with the experimental results, in the following, some considerations and techniques used in the computation are introduced first. The suggested approach is then used to analyze the test cable with and without oil damper. The comparison between experimental and theoretical results is finally performed.

3. SOME CONSIDERATIONS IN COMPUTATION

3.1. TWO-DEGREE-OF-FREEDOM MODEL

Due to the complex nature of non-linear vibration of cable-damper systems, only the non-linear behavior of the system for in-plane harmonic loading around

the first in-plane and out-of-plane natural frequencies of the corresponding linear cable-damper system is considered. Correspondingly, only the first-order harmonic terms in equations (80) and (81) in Part I of the paper are taken into consideration.

$$q_1^{(1)}(t) = R_0 + R_1 \cos \omega t + R_2 \sin \omega t \quad (4)$$

$$q_2^{(1)}(t) = S_0 + S_1 \cos \omega t + S_2 \sin \omega t, \quad (5)$$

where ω is the exciting frequency, and R_0, R_1, R_2, S_0, S_1 and S_2 are the unknown constants.

For the cable without an oil damper, the cable of small vibration amplitude can be seen as a classically damped system and all eigenfunctions are thus real. In such a case, the first order complex equations (62) and (63) in Part I of the paper can be simplified as

$$m_1 I \dot{q}_1^{(1)} + (k_{1r} + ik_{1i})q_1^{(1)} + a_1(q_1^{(1)} + \bar{q}_1^{(1)})^2 + a_2(q_2^{(1)} + \bar{q}_2^{(1)})^2 + a_3(q_1^{(1)} + \bar{q}_1^{(1)})^3 + a_4(q_2^{(1)} + \bar{q}_2^{(1)})^2(q_1^{(1)} + \bar{q}_1^{(1)}) = Q_1, \quad (6)$$

$$m_2 I \dot{q}_2^{(1)} + (k_{2r} + ik_{2i})q_2^{(1)} + b_1(q_1^{(1)} + \bar{q}_1^{(1)})(q_2^{(1)} + \bar{q}_2^{(1)}) + b_3(q_2^{(1)} + \bar{q}_2^{(1)})^3 + b_4(q_1^{(1)} + \bar{q}_1^{(1)})^2(q_2^{(1)} + \bar{q}_2^{(1)}) = Q_2. \quad (7)$$

where $m_1, k_{1r}, k_{1i}, a_1, a_2, a_3, a_4, m_2, k_{2r}, k_{2i}, b_1, b_3$ and b_4 are real constants associated with the first in-plane and out-of-plane vibration modes of the linear cable (see Part I of the paper). Q_1 and Q_2 are the real in-plane and out-of-plane exciting functions, respectively. $q_1^{(1)}$ and $q_2^{(1)}$ are the complex time functions related to the non-linear in-plane and out-of-plane cable motions respectively. The superscript $-$ is the conjugate symbol of a complex functions $i = \sqrt{-1}$. The substitution of the harmonic solutions, equations (4) and (5) into equations (6) and (7) leads to the six-coupled algebraic non-linear equations about the six unknown real constants. The Newton-Raphson computation method is then used to seek the six unknown real constants and thus the non-linear dynamic response of the cable.

For the cable with an oil damper, the system is a non-classically damped system and the eigenfunctions are complex. The first order harmonic solutions, Equations (4) and (5), containing the 12 unknown constants should be substituted into the general equations of motion [equations (62) and (63) presented in Part I of the paper] in a similar way to the case of the cable without an oil damper to obtain the 12 coupled algebraic non-linear equations about these unknown constants. The Newton-Raphson method is then applied to find the solutions of dynamic response for the non-linear cable-damper system.

3.2. ALGORITHM FOR MULTIPLE SOLUTIONS

To capture the non-linear vibration phenomena of the cable or cable-damper system such as transition from in-plane motion to non-planar motion, multiple solutions, and response jump, some proper algorithms should be used in computation. For the sake of clarification, let us take the cable without oil damper as an example to explain the algorithm used in this study.

When applying the Newton–Raphson method, the initial values of R_0 , R_1 , R_2 and thus the initial value of $q_1^{(1)}$ or the initial dynamic displacement amplitude a_1 at the mid-point of the cable can be first obtained from the linear system without referring to the out-of-plane quantities. This is because for the linear system, the in-plane and out-of-plane motions are not coupled.

Then, attention is paid to the three non-linear algebraic equations for the out-of-plane motion obtained from the harmonic balance method [see Eq. (83) in Part I of the paper when $L = 0, 1$ and 2]. Since the static component S_0 is much smaller than S_1 and S_2 , its higher order terms in equation (83) when $L = 0$ can be neglected and S_0 can be expressed into a function of S_1 , S_2 and the initial in-plane value R_0 , R_1 and R_2 . The substitution S_0 into the other two equations [Eq. (83) when $L = 1$ and 2] then gives the two linear homogeneous equations about S_1 and S_2 . In these two linear homogeneous equations, the coefficients of S_1 and S_2 are the function of the initial in-plane values R_0 , R_1 and R_2 and the amplitude of the out-of-plane response only. When the eigenfunction is properly normalized, the out-of-plane displacement response is $q_2^{(1)}$, and the amplitude of the out-of-plane response is actually $a_2 = \sqrt{S_1^2 + S_2^2}$. To obtain the non-trivial solutions of S_1 and S_2 , the determinant of the coefficient matrix of the two linear homogeneous equations should be equal to zero, from which a polynomial function of a_2 can be obtained. If the real and positive roots of a_2 are found from this polynomial function, the internal resonance between in-plane and out-of-plane mode vibration and thus the non-planar cable motion may be thought to have occurred. Otherwise, there is no out-of-plane motion of the cable.

For each root of a_2 , the initial values of S_0 , S_1 and S_2 can be determined by the back-substitution. Together with the initial values of R_0 , R_1 and R_2 , the Newton–Raphson method can be applied to find the exact solutions of R_0 , R_1 , R_2 , S_0 , S_1 and S_2 and hence the in-plane and out-of-plane displacement response amplitudes a_1 and a_2 . The algorithms described above can ensure that the out-of-plane solutions will converge to the non-trivial solutions and provide a criterion for judgment of the bifurcation point.

3.3. STABILITY OF RESPONSE

The resulting dynamic displacement response of the non-linear cable or cable–damper system can be classified as a stable response or an unstable response according to a stability analysis. Again, consider the cable without oil damper as an example. Let the six constants R_0 , R_1 , R_2 , S_0 , S_1 and S_2 in the harmonic solutions (4) and (5) have small disturbances ΔR_0 , ΔR_1 , ΔR_2 , ΔS_0 , ΔS_1 and ΔS_2 . One can then write the solutions containing these small disturbances as follows:

$$q_1^{(1)} = R_0 + \Delta R_0 + (R_1 + \Delta R_1)\cos n\omega t + (R_2 + \Delta R_2)\sin n\omega t, \quad (8)$$

$$q_2^{(1)} = S_0 + \Delta S_0 + (S_1 + \Delta S_1)\cos n\omega t + (S_2 + \Delta S_2)\sin n\omega t. \quad (9)$$

Substituting them into equations (6) and (7) and neglecting the higher-order terms, a set of linearized equations can be achieved:

$$[A] \frac{d}{dt} \{\Delta Z\} + [B] \{\Delta Z\} = 0 \quad (10)$$

in which $[A]$ and $[B]$ are the two constant matrices whose elements are determined by the constant coefficients of equations (6) and (7) and the six constants R_0, R_1, R_2, S_0, S_1 and S_2 . $\{\Delta Z\}$ is the vector consisting of the disturbances $\Delta R_0, \Delta R_1, \Delta R_2, \Delta S_0, \Delta S_1$ and ΔS_2 .

If and only if none of the eigenvalues of the system [equation (10)] has a positive-definite real part, the solution of equations (6) and (7) or the motion of the system is stable. Otherwise, it is unstable.

4. CABLE WITHOUT DAMPER

Although the dynamic response at any point of the cable can be computed, only the normal and lateral components of the displacement response, a_1 and a_2 , at the mid-point of the cable are presented in the following to demonstrate the non-linear behavior of the cable.

4.1. NON-LINEAR RESPONSE CHARACTERISTICS

Figure 2 shows both the in-plane and out-of-plane steady-state frequency-response curves of the cable subject to a harmonic force of 5 N amplitude. In this figure, the x -co-ordinate is the ratio of the exciting frequency ω to the natural frequency of the first in-plane undamped linear vibration mode, ω_{0in} , and the y -coordinates is the corresponding displacement response amplitudes at the midspan, a_1 and a_2 . The cable has a static tension of 130 N and the natural frequencies of the first in-plane and out-of-plane linear vibration modes are 9.35 and 9.29 Hz, respectively. A small internal damping with a damping coefficient of 0.0147 N/s/m² measured from the test cable is also taken into consideration.

To demonstrate the non-linear vibration behavior of such a taut cable, the exciting frequency is increased slowly from a frequency ratio much less than 1 where the planar motion is expected. The in-plane stable displacement response amplitude a_1 is found to increase with the increasing excitation frequency until the frequency ratio reaches about 1.003 at Point A, where a Hopf bifurcation occurs and the out-of-plane displacement response amplitude a_2 starts to be excited out. With the further increase of excitation frequency, multiple solutions are found. One is for the pure in-plane unstable vibration that may reach very high response amplitude until Point D and then jump downward suddenly to a pure in-plane stable vibration of very small amplitude. The other solution is for the non-planar stable vibration until Point C. In the non-planar motion, the in-plane response amplitude is larger than the out-of-plane response amplitude but the rate of increasing of the out-of-plane response amplitude is faster than that of the in-plane response amplitude. At Point C where the frequency ratio is about 1.095, the

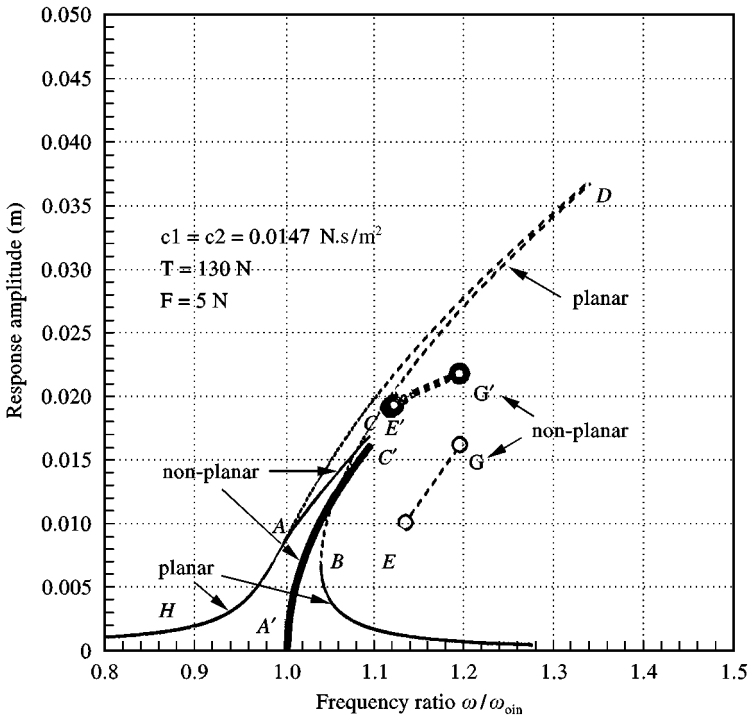

Figure 2. Frequency-response curves of cable without damper. — Stable in-plane a_1 ; ○ unstable in-plane a_1 ; — stable out-of-plane a_2 ; ● unstable out-of-plane a_2 .

non-planar cable motion suddenly jumps back to a pure in-plane stable vibration of a small vibration amplitude. As the excitation frequency further increases from Point C, the unstable non-planar solutions are obtained (see E-G and E'-G') apart from the stable in-plane cable motion of small amplitude.

When the frequency ratio is swept down from 1.28, the cable exhibits pure in-plane stable motion and the in-plane response amplitude increases with the decrease of the exciting frequency until Point B. Immediately after Point B, the in-plane stable motion has a sudden upward jump to become the non-planar stable motion following the curves of A-C and A'-C' and then the in-plane stable response following the curve of A-H. Clearly, for the studied cable, there is a 1:1 internal resonance between the first in-plane and out-of-plane modes of the cable. This internal resonance induces the non-planar cable motion and reduces the in-plane response amplitude. These observations are very similar to those observed from a taut string [5].

4.2. EFFECTS OF CABLE SAG

To seek the effects of cable sag on non-linear dynamic behaviour of stay cables, the static tension of the studied cable is reduced to 42 N while other cable

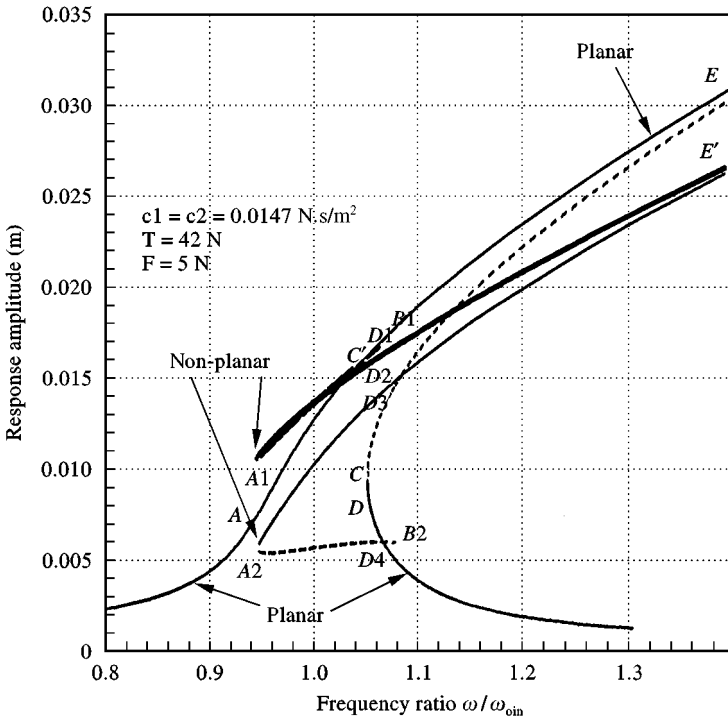

Figure 3. Effects of cable sag on non-linear vibration behavior. — Stable in-plane a_1 ; --- unstable in-plane a_1 ; ··· unstable out-of-plane a_2 ; — stable out-of-plane a_2 .

parameters remain unchanged. Due to the change of the cable tension, the cable sag parameter $\log \lambda^2$ is now increased from -0.84 to 0.64 and the natural frequencies of the first in-plane and out-of-plane linear modes of vibration become 6.134 and 5.294 Hz. The ratio of the two natural frequencies is obviously different from that for the cable having the static tension of 130 N.

The frequency-response curves of the cable subject to a harmonic force of 5 N amplitude are computed and the results are shown in Figure 3. Compared with Figure 2, it is noted that the non-linear vibration behavior of the sag cable is significantly different from the taut cable. By forward sweeping of the exciting frequency, at Point A with a frequency ratio of 0.947 , the in-plane stable motion jumps to the non-planar motion of the cable, in which the in-plane response amplitude a_1 in the pure in-plane cable vibration jumps down while the out-of-plane response amplitude a_2 suddenly appears with the amplitude larger than the in-plane response amplitude. There are two solutions involved in the non-planar cable motion. One represents the stable non-planar motion over a wide range of frequency ratio and the other indicates the unstable non-planar motion over a relatively narrow range of frequency ratio (curves A1–B1 and A2–B2). The in-plane response amplitude in the unstable non-planar motion is smaller than that in the stable non-planar motion while the out-of-plane response amplitudes in both cases are similar. It is also noted from Figure 3 that apart from the non-planar

motion of the cable, there is the stable pure in-plane motion after Point A until Point E where the in-plane motion jumps down to the stable in-plane motion of very small amplitude. In practice, the occurrence of either the stable non-planar motion or the stable in-plane motion may depend on the initial condition.

When the excitation frequency is swept down from 1.3, the response amplitude a_1 increases gradually until Point D with a 1.065 frequency ratio, where the pure in-plane motion of the cable may jump to one of the two possible non-planar oscillations (curves A_1-D_1 and A_2-D_4 or curves A_1-D_2 and A_2-D_3). If the pure stable in-plane vibration can remain until Point C at a 1.052 frequency ratio, then the in-plane motion may jump from Point C to Point C' to another stable in-plane motion curve (curve A-C'). All the possible motions mentioned above are sustained on their own route until the frequency ratio is reduced to 0.947 at Points A_1 , A and A_2 . After that, all the possible cable motions return to the pure in-plane vibration.

It is seen from the above discussion that the internal resonance phenomenon in the sag cable seems to be different from those occurring in the relatively taut cable of 130 N tension. In fact, this type of internal resonance phenomenon may be seen as one between 1 : 1 internal resonance and 2 : 1 internal resonance which may occur if the sag of the cable is further reduced to its first frequency avoidance.

4.3. EFFECTS OF CABLE INTERNAL DAMPING

To facilitate the comparison of non-linear vibration behavior between the cable with and without oil damper, the effects of viscous internal damping on non-linear cable dynamic response are investigated. Figure 4 shows the frequency-response curves of the cable with a static tension of 130 N and an internal damping of damper coefficient $c_1 = c_2 = 0.0433$ Ns/m². This internal damping provides about 1% of modal damping ratios in both the first in-plane and out-of-plane linear modes of vibration of the cable. The cable is subject to an in-plane harmonic excitation of 5 N amplitude. It is seen that the non-linear behavior of the cable vibration becomes very weak compared with the same cable with very small internal damping (see Figure 2). This is consistent with the report from Miyata [11] that a logarithmic decrement of 0.05 may suppress wind-induced cable vibration of large amplitude. In Figure 4, there is also the Hopf bifurcation point (Point A), where the stable non-planar motion of the cable occurs but within a very narrow range of frequency ratio. The amplitudes of both in-plane and out-of-plane displacements in the non-planar motion are also much smaller than those occurring in the cable of very small internal damping (see Figure 2). The frequency ratio where the bifurcation occurs in this case is 1.013 compared to 1.003 in the cable with very small internal damping (see Figure 2). Furthermore, other non-planar stable solutions are found within a very short range of frequency ratio of about 1.055 (see Points C and C'), in which the in-plane response amplitude jumps to a high value while the out-of-plane response amplitude drops to a very low value.

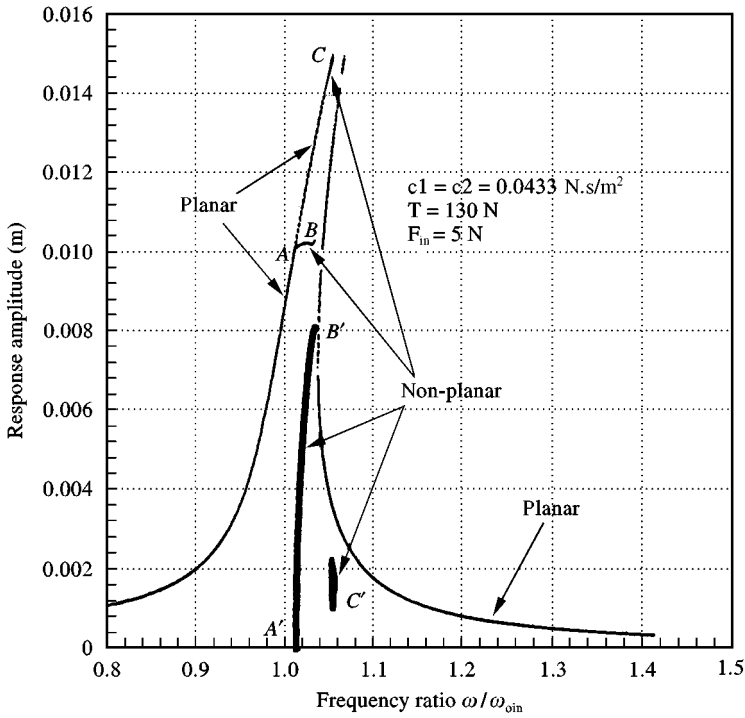

Figure 4. Effects of cable internal damping on non-linear vibration behavior. — Stable in-plane a_1 ; — stable out-of-plane a_2 ; - - - unstable in-plane a_1 .

5. CABLE WITH OIL DAMPER

Consider an oil damper attached to the cable in the cable static equilibrium plane and normal to the cable length at the location of 3% L measured from the lower cable support (see Figure 1). The hybrid method is then applied to the corresponding linear cable-damper system to find the relationship between the modal damping ratio in the first in-plane vibration mode and damper damping coefficient (or called damper size). The results are plotted in Figure 5 for the cable of 130 and 42 N tension. It is seen that there is an optimum damper size of about 22.2 Ns/m for the cable of 130 N tension and 15 Ns/m for the cable of 42 N tension, providing the maximum modal damping ratio in the first in-plane vibration mode of 1.86% for the cable of 130 N tension and of 1.48% for the cable of 42 N tension. One factor causing the maximum modal damping ratio in the cable of 42 N tension to be smaller than that in the cable of 130 N tension are frequency avoidance effects. More information on the frequency avoidance effects and modal damping ratios in higher vibration modes of the linear cable-damper system can be found in reference [12].

Now let us consider the cable of 130 N tension with an oil damper of 6.0 Ns/m damping coefficient which is not the optimum damper size. The modal damping ratio provided by this damper in the first in-plane mode of the cable is estimated at

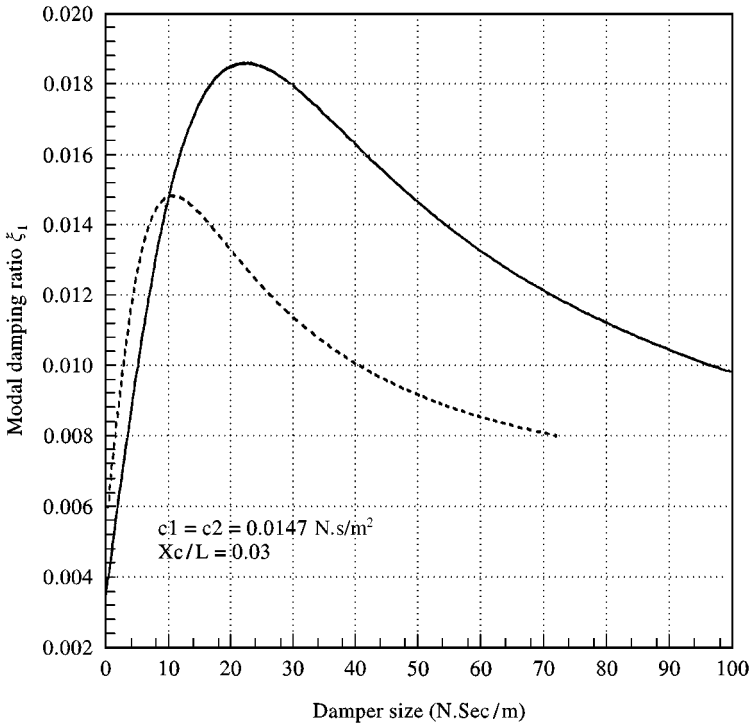

Figure 5. Variations of first in-plane modal damping ratio with damper size. — $T = 130$ N; --- $T = 42$ N.

about 1.06% from Figure 5. The frequency-response curves of the cable-damper system subject to a harmonic excitation of 5 N amplitude are plotted in Figure 6. It is seen that the non-linear vibration behavior of such a non-proportionally damped cable system is similar to that of the same cable without an oil damper, as shown in Figures 2 and 4. One-to-one internal resonance also occurs at the frequency ratio of about 1. The maximum in-plane and out-of-plane response amplitudes in the non-planar motion are almost equal to those for the cable not equipped with the damper (see Figure 2). This is because the oil damper is installed in the cable plane so that the out-of-plane modal damping of the cable is not changed by the oil damper. On the other hand, the pure unstable in-plane response amplitude of the cable in this case is compatible with that for the cable without oil damper but with an internal damper ratio of similar value (see Figure 4). Obviously, the non-planar stable response amplitudes of the cable without damper but with a similar internal damping ratio (see Figure 4) are much lower than those in the cable-damper system. Again, this is because the internal damping ratio in the out-of-plane vibration mode is smaller in the cable-damper system. Clearly, the cable with an improper designed oil damper still exhibits non-linear vibration behavior.

When damper size is increased to the optimum value of 22.2 N s/m, it is found that the dynamic response of such a cable-damper system exhibits almost linear behavior, as shown in Figure 7. The dynamic response of the system is dominated

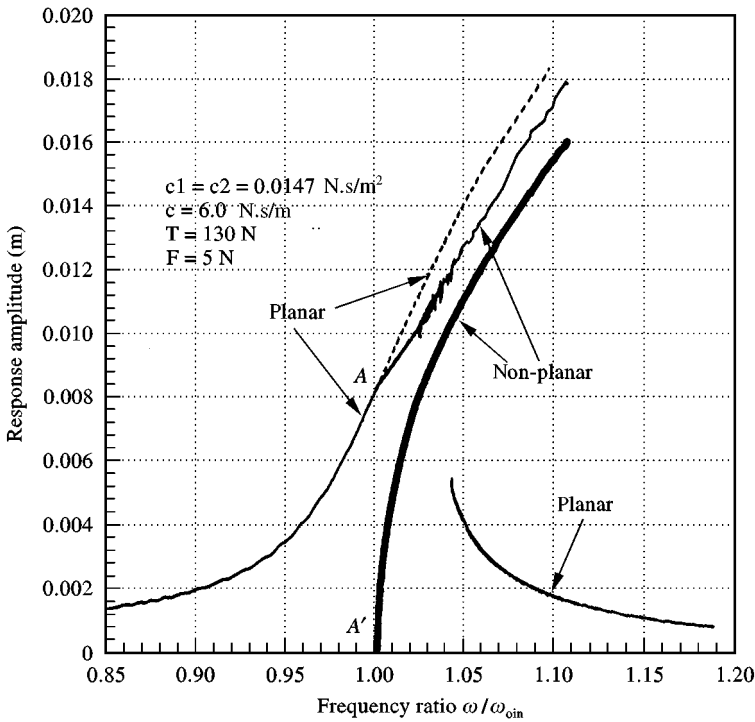

Figure 6. Frequency-response curves of cable-damper system with small damper size. — Stable in-plane a_1 ; — stable out-of-plane a_2 ; --- unstable in-plane a_1 .

by the pure in-plane stable vibration. The non-planar motion covers only over a very narrow range of frequency ratio but the out-of-plane displacement amplitude is quite high. The frequency ratio of the bifurcation point A however remains unchanged, compared with the cable without damper.

From the above discussions, two points may be noted. The first is that a properly selected damper attached to a stay cable in its static equilibrium plane can effectively reduce in-plane non-linear response. The second is that the installation of oil damper may reduce the in-plane response amplitude in a non-planar motion but when the internal resonance is fully developed, the damper may lose its functions to suppress both in-plane and out-of-plane response amplitudes. However, the latter can be improved by installing a pair of oil dampers to provide modal damping ratios in both in plane and out of plane, as discussed in reference [12] for a linear cable-damper system.

6. COMPARISON WITH EXPERIMENTAL RESULTS

6.1. CABLE WITHOUT DAMPER

Figure 8 shows the comparison of the in-plane displacement frequency response curves of the cable without an oil damper and subject to a harmonic excitation of

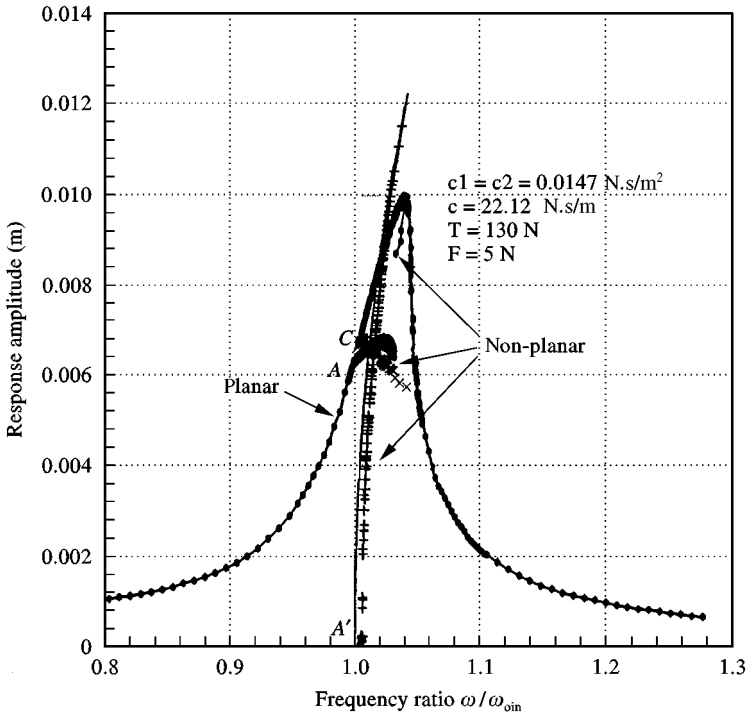

Figure 7. Frequency-response curves of cable-damper system with optimum damper size. ● Stable in-plane a_1 ; × unstable in-plane a_1 ; — stable out-of-plane a_2 ; + unstable out-of-plane a_2 .

1.414 N amplitude around the first natural frequency of the corresponding linear cable. The cable tension used here is 130 N and the dynamic force is located at 0.5% of the cable length measured from the top anchor of the cable. Theoretical results show a weak non-linearity in the cable vibration. For the sweep-up excitation frequency, a bifurcation occurs at Point A, after which either the planar cable vibration becomes unstable (Point A to Point B) or the stable non-planar vibration occurs (Point A to Point C). Clearly, the theoretical stable non-planar solution matches the sweep-up test results. Although the theoretical study predicts that after Point C, the stable non-planar response of the cable may jump up to the stable planar solution again (towards Point E), the test results do not provide this evidence. The test results actually follow the theoretical in-plane displacement responses predicted from the sweep-down excitation frequency until Point D, where the theoretical response becomes unstable.

When the amplitude of the exciting force is increased to 5 N, non-linear cable vibration behavior and 1:1 internal resonance between the first in-plane and out-of-plane cable vibrations are observed from both experiment and theoretical analysis. As shown in Figure 9, a bifurcation of cable response occurs at Point A (1.003 Hz excitation frequency) in both experimental and theoretical frequency response curves. If the excitation frequency is further increased from Point A, either the stable non-planar cable vibration occurs or the unstable in-plane cable

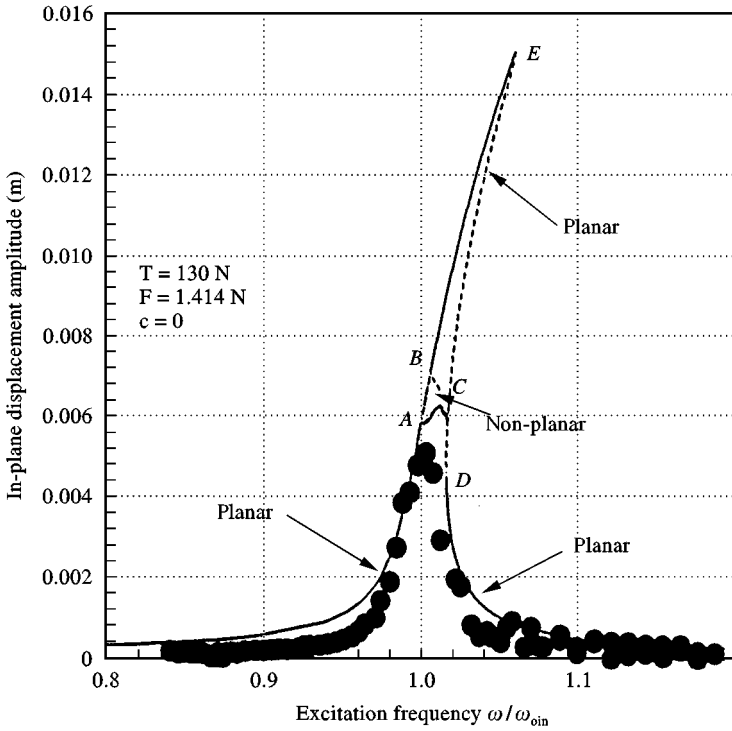

Figure 8. Comparison of in-plane frequency-response curve of cable without damper ($F = 1.414$ N). — Theoretically stable; --- theoretically unstable; ● measured.

vibration happens. The test cable actually follows the route of the stable non-planar cable vibration until Point C where the cable vibration suddenly drops and then follows the sweep-down frequency response curve. The measured sweep-down frequency response curve is in good agreement with the theoretical stable sweep-down frequency response curve. All unstable frequency responses predicted by the theory are not observed in the tests. Clearly, the theoretical response curve can capture basic non-linear behavior and internal resonance of a sag cable.

6.2. CABLE WITH DAMPER

With respect to the damper effect on mitigation on non-linear cable vibration, the measured and computed displacement responses of the cable with an oil damper are presented in Figure 10. The damper size is 22.12 kg/s and the excitation frequency is around the first in-plane modal resonance. The cable tension and excitation amplitude are kept as 130 and 5 N, respectively. The damper is located at 3% of the cable length near the bottom anchor. Compared with Figure 9, both theoretical and experimental cable responses are significantly reduced because of the oil damper. The reduction in the resonance peak reaches more than 50%. The non-linear cable vibration thus becomes very weak, particularly for the cable in

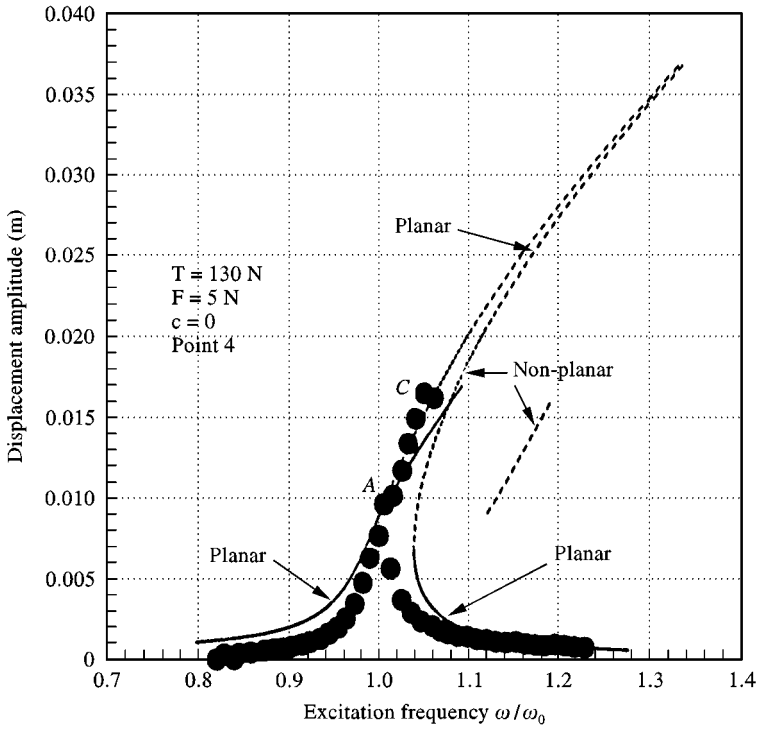

Figure 9. Comparison of in-plane frequency-response curve of cable without damper ($F = 5 \text{ N}$). — Theoretically stable; --- theoretically unstable; ● measured.

tests. Although the bifurcation and 1:1 internal resonance are still found in the theoretical frequency response curve after Point A, it is hardly observed in the test cable with the oil damper. This may be attributed to the additional constraint from the connections between the exciter and cable and between the damper and cable in the tests.

7. CONCLUSIONS

The formulation derived in Part I of this paper has been applied to investigate non-linear vibration behavior of inclined sag cables with and without oil dampers in cable-stayed bridges. The theoretical results were compared with the experimental ones, and the agreement was found to be satisfactory. Both the experimental and theoretical results demonstrated main features of non-linear cable vibration, which include response hardening, response bifurcation, 1:1 internal resonance between the first in-plane and out-of-plane modes of vibration in a relatively taut cable, and response jump. Cable sag and cable internal structural damping ratio affected these types of non-linear cable vibration behavior. Both experimental and theoretical studies demonstrated that an oil damper with an appropriate damping coefficient being selected could effectively suppress the

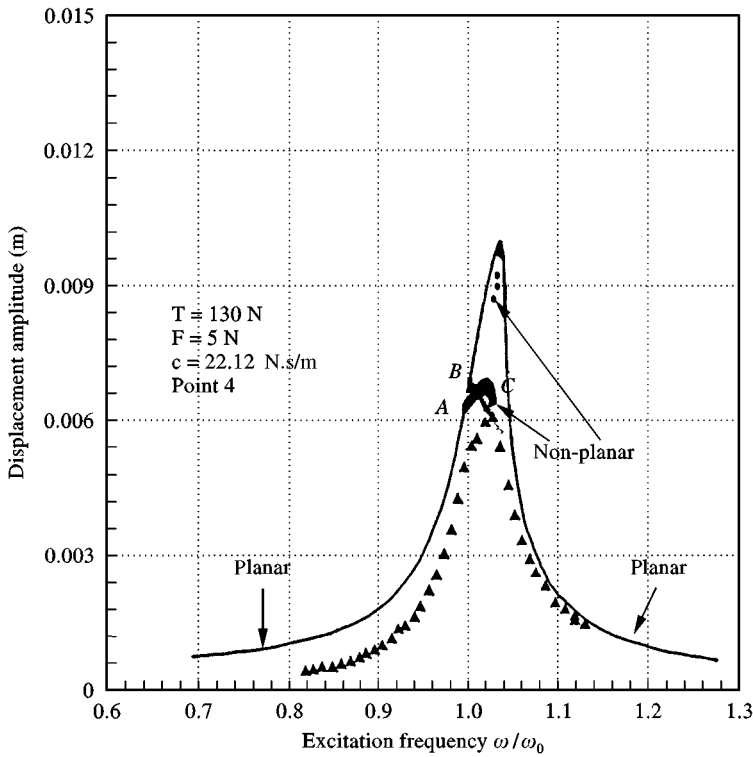

Figure 10. Comparison of in-plane frequency-response curve of cable with damper ($F = 5$ N). — Theoretical stable; • theoretical unstable; ▲ measured.

non-linear in-plane response amplitude in both the pure in-plane motion and non-planar motion.

ACKNOWLEDGMENT

The work described in this paper was partially supported by a grant from the Research Grants Council of the Hong Kong Special Administrative Region (Project No. PolyU5066/97E).

REFERENCES

1. G. F. CARRIER 1945 *Quarterly of Applied Mathematics* **3**, 157–165. On the non-linear vibration problem of the elastic string.
2. G. V. ANAND 1966 *Journal of Acoustical Society of America* **40**, 1517–1528. Non-linear resonance in stretched strings with viscous damping.
3. R. NARASIMHA 1968 *Journal of Sound and Vibration* **8**, 134–136. Non-linear vibration of an elastic string.
4. J. W. MILES 1984 *Journal of Acoustical Society of America* **75**, 1505–1510. Resonant, non-planar motion of a stretched string.
5. A. H. NAYFEH and D. T. MOOK 1995 *Nonlinear Oscillations*. New York: John Wiley & Sons Inc.
6. H. M. IRVINE 1981 *Cable Structure*. Cambridge, MA, U.S.A.: MIT Press.

7. N. C. PERKINS 1992 *International Journal of Non-linear Mechanics* **22**, 233–250. Modal interactions in the non-linear response of elastic cables under parametric/external excitation.
8. F. BENEDETTINI and G. REGA 1994 *Proceedings of ASME Winter Annual Meeting*, AMD-192, 39–46. Analysis of finite oscillations of elastic cables under internal/external resonance conditions.
9. F. BENEDETTINI, G. REGA and R. ALAGGIO 1995 *Journal of Sound and Vibration* **182**, 775–798. Non-linear oscillations of a four-degree-of-freedom model of a suspended cable under multiple internal resonance conditions.
10. C. L. LEE and N. C. PERKINS 1995 *Non-linear Dynamics* **8**, 45–63. Three-dimensional oscillations of suspended cables involving simultaneous internal resonances.
11. Y. MIYATA 1991 *Proceedings of the Seminar on Cable-Stayed Bridges: Recent Developments and their Future*, Yokohama, Japan, 235–256. Amsterdam: Elsevier. Design considerations for wind effects on long-span cable-stayed bridges.
12. Y. L. XU and Z. YU 1998 *Journal of Sound and Vibration* **214**, 675–693. Mitigation of three dimensional vibration of inclined sag cable using discrete oil dampers, Part II: application.