



THE VIBRO-ACOUSTIC MODELLING OF SLAB TRACK WITH EMBEDDED RAILS

S. VAN LIER

NS Technical Research, P.O. Box 8125, 3503 RC Utrecht, Netherlands

(Received in final form 23 September 1999)

The application of concrete slab track in railways has certain advantages compared with conventional ballasted track, but conventional slab track structures generally produce more noise than ballasted track. For this reason a “silent slab track” has been developed in the Dutch ICES “Stiller Treinverkeer” project (silent railway traffic) by optimizing the track. In the design, the rails are embedded in a cork-filled elastomeric material. The paper discusses the vibro-acoustic modelling of this track using the simulation package “TWINS”, combined with finite element techniques. The model evaluates the one-third octave band sound power spectrum radiated by train wheels and track, and provides for a tool to optimize the track design. Three track types are compared using the vibro-acoustic model: an existing slab track with embedded UIC54 rails, a newly designed, acoustically optimized slab track with a less stiff rail embedded in a stiffer elastomere, and, as a reference, a ballasted track. The models of the existing tracks have been validated with measurements. Calculations indicate that the optimized slab track will emit between 4 and 6 dB(A) less noise than the ballasted track. The existing slab track produces between 1.5 and 3 dB(A) more noise than the ballasted track; this is caused by resonances in the elastomeric moulding material in the frequency range determining the dB(A)-level.

© 2000 Academic Press

1. INTRODUCTION

Noise and vibration are the main sources of the environmental impact of railway traffic. In the Dutch ICES “Stiller Treinverkeer” project (silent railway traffic) new techniques have been developed to realize a 10 dB(A) reduction of the rolling noise emission of freight trains. This is done by optimizing the train and the track design. One of the minor goals is a 5 dB(A) reduction of the rolling noise emitted by the track. A ballastless track structure with continuously supported rails has been chosen for optimization; rails embedded in a cork-filled elastomers, mounted on a trough in the concrete slab.

The application of slab track has certain civil advantages compared with conventional ballasted track, but existing slab track structures produce more noise than ballasted track. Vibration and noise measurements on an existing slab track with embedded rails have shown that the total emitted rolling noise is about 2 dB(A) higher, and the noise emitted by the track is about 3 dB(A) higher, than for

ballasted track. So the noise reduction effort on the track optimization has to be even greater for slab track than for ballasted track. On the other hand, the track design can be changed more radically than ballasted track, because it is continuously supported.

In this paper, the predicted noise emission of a newly designed slab track with embedded rails is compared with the noise emission of existing slab track and existing ballasted track; these tracks are presented in section 3. In section 4 the modelling method and its validation are discussed. The calculation results are shown and analyzed in section 5, followed by conclusions and further prospects of research. First, however, some basic notions about rolling noise are summarized.

2. ROLLING NOISE OF TRAINS

At usual freight train speeds (typically 100 km/h) the main noise source is the rolling noise. This is caused by the vibration and subsequent sound radiation of train wheels, rails and sleepers. These vibrations are induced by the surface roughness in the contact patch between wheel and rail; these are surface irregularities with wavelengths between 1 and 10 cm and amplitudes between 1 and 50 μm . The relation between wheel and rail roughness and railway noise was input into a comprehensive computer package, called TWINS [1, 2], developed under contract from the European Railway Research Institute (ERRI).

TWINS is a linear model, acting in the frequency domain. The input for the program consists of the combined wheel/rail roughness spectrum and a dynamic model of the train wheel, the track and their interaction in the contact patch. The dynamic description of the train wheel is given by the modal parameters (the eigenfrequencies, the mode shapes of vibration and the modal masses). For the dynamic description of the track, three complementary models are available. In the first model the track is considered as an infinite elastic beam (the rail), continuously supported by a spring (the rail pad), a mass (the sleeper) and a spring (the ballast). In the second model the rail is not continuously, but periodically supported; in this way the so-called pinned-pinned effects, related to the sleeper separation, can be calculated. In the third model, a thin slice of the track (e.g. 1 cm long) is modelled in a FEM model, and the mass and stiffness matrices of the slice are input into TWINS. Then the frequency response function (FRF) of the infinite track is calculated from the dynamic model of the finite slice using periodic structure theory [1].

The contact forces are calculated from the roughness input and the wheel, rail and contact receptances (transfer function from force to displacement). Using the wheel and rail receptances, the vibrations of wheel, rail and sleeper are calculated. Lastly, the emitted sound power and the sound pressure at some receiver position are determined using sound radiation and propagation models. An extensive validation program showed that TWINS predicts the A-weighted sound level at an immission point consistently around 2 dB(A) too high, with a standard deviation of 1 dB(A), while the sound pressure spectra reveal a standard deviation of about 5 dB per one-third octave band [3]. For the TWINS calculations presented in this paper, version 2.4 was used; for the FEM calculations, ANSYS version 5.2 was used.

3. TRACKS

Three tracks are evaluated acoustically in the present paper. The first is a concrete slab track with embedded rails built in the 1970s near Deurne, the Netherlands. The rail (UIC54) is continuously supported by a pad and embedded in a cork-filled elastomer (see Figure 1). To save material, PVC tubes are embedded on either side of the rail. The embedded rails are laid in 170 mm wide gutters in a 0.5 m thick concrete plate, which lies directly on the soil.

The second is an acoustically optimized slab track with embedded rails. From a global trend analysis executed with TWINS it is known that a less stiff rail on a stiffer suspension may yield a considerable noise reduction [4]. This resulted in the design shown in Figure 2. The rail (named SA42) is only 80 mm high and

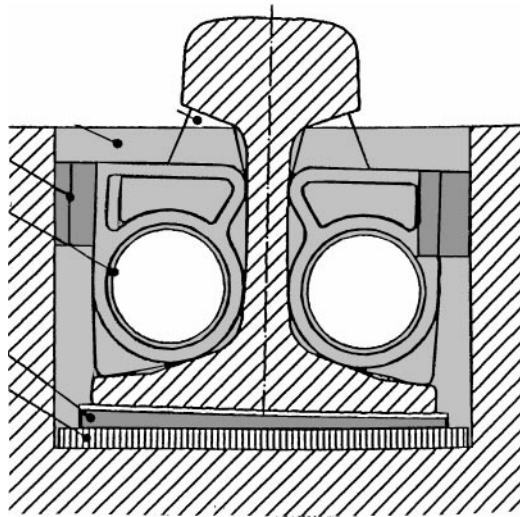

Figure 1. Cross-sectional view of the existing slab track.

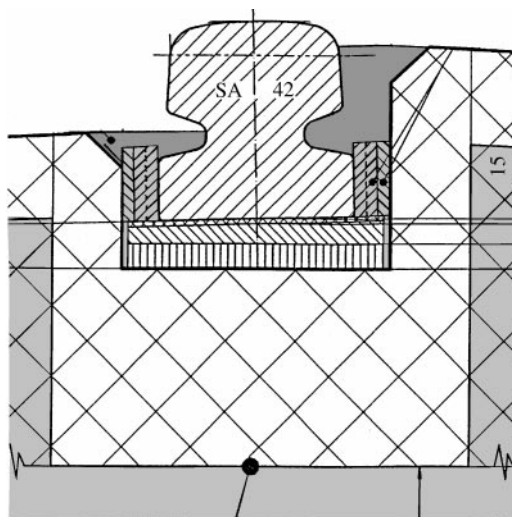

Figure 2. Cross-sectional view of the optimized slab track.

80 mm wide. It is continuously supported by a stiffer pad and asymmetrically embedded in a stiffer elastomer. The concrete plate is less thick than the slab in Figure 1. (0.35 m on the average) and the gutters are 110 mm wide.

The third track considered is used as a reference track. It consists of UIC54 rails on monoblock concrete sleepers in ballast.

4. BUILDING AND VALIDATION OF A TWINS MODEL FOR EMBEDDED RAILS

4.1. MODEL INPUT

During a measurement exercise on the existing slab track, the frequency response function (FRF) of the track and the decay rate along the rail were measured by means of hammer excitation. In addition, the vibration of the rail head, the concrete slab and the elastomeric surface, and the sound pressure levels at four immission points were measured during several train passages (Dutch intercity trains) with an average speed of 100 km/h. It was found that the contribution of the concrete slab to the total noise (in dB(A)) is small, and that resonances of the elastomer around 500 Hz may contribute considerably to the total noise [4]. No roughness measurements were made.

These passages were modelled in TWINS. The wheel was dynamically described by means of experimental and FEM modal analysis. The third track modelling option in TWINS (a FEM model of a track slice) was chosen, so that the contribution of the surface of the moulding material to the radiated noise could be estimated. The concrete slab was modelled as a rigid structure, for the dynamic model this is a reasonable assumption. The material characteristics were taken from handbooks and specifications from the supplier. However, the Young's modulus of the elastomer, which depends on many operational conditions, was tuned in such a way that the first two measured and predicted resonance frequencies agreed as closely as possible. In addition, the loss factor of the rail had to be raised considerably above its physical value in order to match the predicted and the measured decay rates. As an illustration, the deformed shape of the vertical track resonance at 160 Hz is given in Figure 3.

In the TWINS rail radiation module, the sound power per wavetype is calculated from the waveshapes. (By broad-band excitation of the rail during a train passage, a large number of wavetypes are excited, each with their own wavelengths and decay rates). It is assumed that the radiation pattern is two-dimensional, and that the contributions of all wavetypes can be energetically summed as incoherent noise sources. The rail is geometrically modelled as four rectangular boxes with a number of equivalent sound sources inside. This geometrical model is not suitable for embedded rails, so a FEM model of the rail radiation per wavetype has been developed instead. Figure 4 shows an example of the sound pressure field radiated by the lowest order lateral waveshape at 1 kHz.

The model described above does not contain the contribution of the concrete slab to the total noise. This contribution is expected to be small for the existing slab track, but it may be considerable for the new slab track. A simplified model was

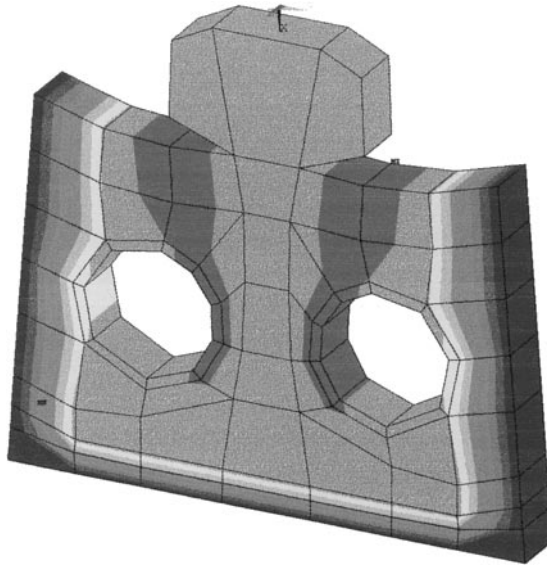

Figure 3. Vertical resonance of the existing slab track at 160 Hz, calculated with FEM.

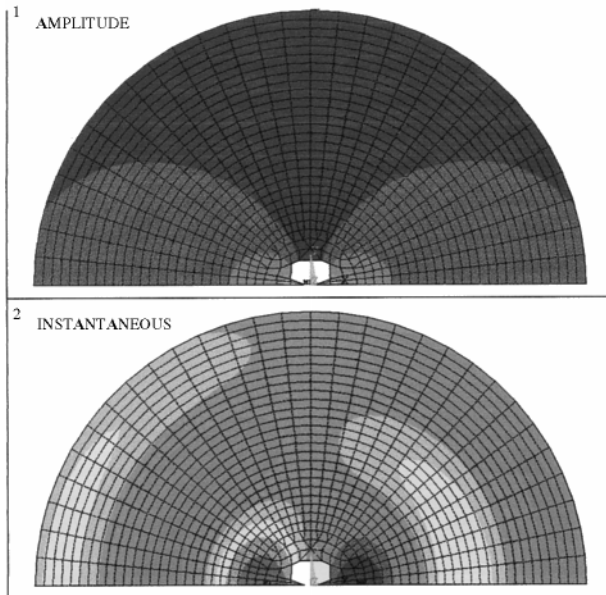

Figure 4. Sound pressure field of a lateral waveshape of the existing slab track at 1 kHz: amplitude (upper part) and instantaneous pressure (lower part).

therefore built (with the continuously supported beam on mass model, the first track modelling option in TWINS) to estimate the contribution of the slab. For this model, the equivalent slab mass and ballast stiffness were tuned to measured vibration levels. The slab contribution was then added to the calculation results of the detailed model.

4.2. RESULTS FOR EXISTING SLAB TRACK

No roughness levels were known, so the model cannot produce realistic absolute values. However, all quantities depend linearly on the roughness level, and so their calculated level relative to a chosen reference quantity can be compared with the corresponding measured relative quantity. As a reference quantity, the vertical vibration level of the rail head is chosen here. As an example, Figure 5 shows the calculated and measured vibration ratios of the moulding material surface to the rail head (both in vertical direction) during a train passage. The agreement is very good; the measured vibration ratio is reproduced within 3 dB and the trends are very similar. The measured and calculated vibration ratios of the rail head in lateral direction and the concrete slab in vertical direction, both relative to the vertical rail head vibration, also agree within about 3 dB, which inspires confidence in the model. For the validation of the radiation model, Figure 6 shows calculated and measured sound pressure spectra at an immission point at 1 m from the rail (outside the track) and 0.5 m above the rail head, relative to the vertical vibration level of the rail head. It can be seen that the sound pressure is slightly overpredicted on average, especially in the frequency range between 400 and 1000 Hz. The deviation at high frequencies is larger, because the noise contribution of the wheel, which is dominant beyond 2 kHz, is only included in the measured, but not in the calculated, sound pressure spectrum. A more elaborate discussion of these results is given in reference [5].

In order to validate the order of magnitude of the sound pressure level, an estimation was made of the input roughness spectrum, based on 2-year old rail roughness spectra measured close to the location, and on typical wheel roughness spectra of Dutch intercity trains. At an average train speed of 100 km/h, the

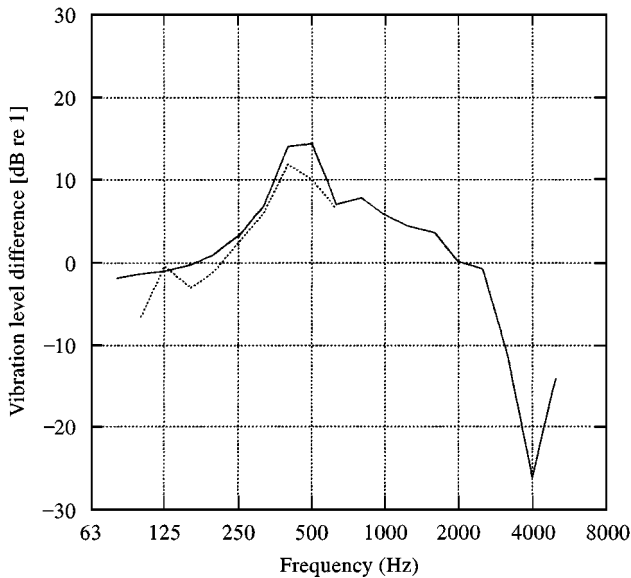

Figure 5. Vibration ratio of moulding material surface to rail head in vertical direction during pass-by: calculated (—) versus measured (···).

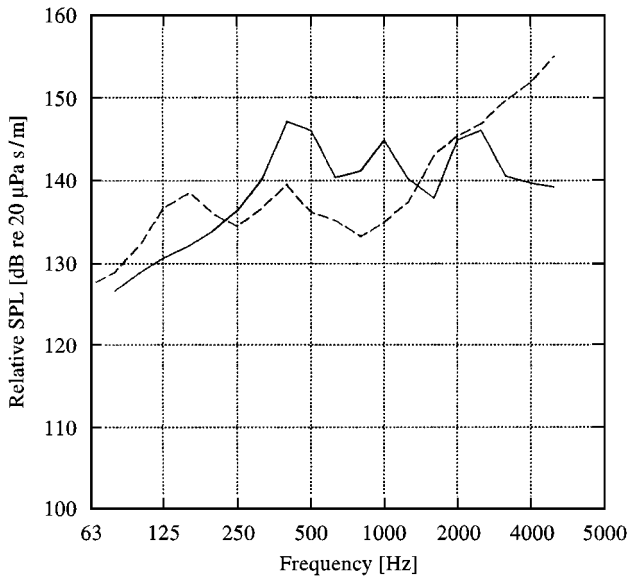

Figure 6. Sound pressure level at 1 m outside and 0.5 m above the rail head relative to vertical rail head vibrations: calculated (—) versus measured (---).

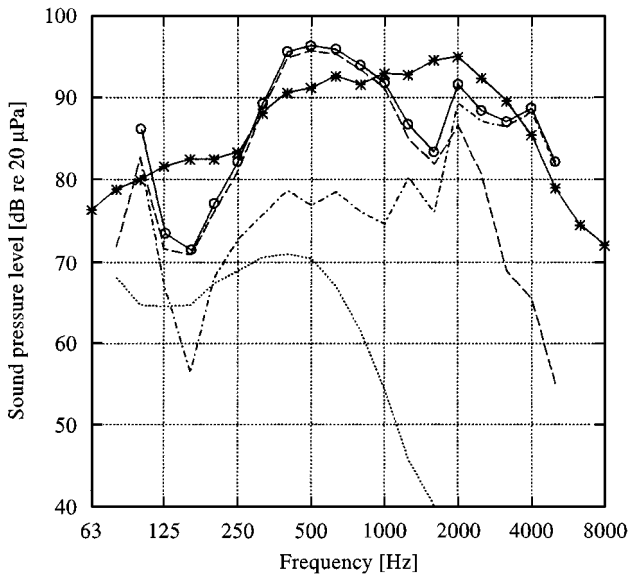

Figure 7. Sound pressure spectrum at 1 m outside and 0.5 m above the rail head: calculated contributions of rail plus moulding material (—), slab (···), wheel (-·-·-) and total (○-○) versus measured (*-*).

calculated A-weighted total sound pressure level at the immission point a 1 m was 101.3 dB(A), whereas the measurements yielded 102.9 dB(A), an underprediction of 1.6 dB(A). Figure 7 shows that the measured sound pressure spectrum is rather smooth, whereas the predicted spectrum is more “peaky”, with deviations up to

10 dB between the two spectra in some one-third octave bands, somewhat higher than for the validation results presented in reference [3]. However, the order to magnitude is well reproduced by the model.

5. ACOUSTICAL COMPARISON OF THREE TRACK TYPES

5.1. RESULTS

For the acoustically optimized slab track a TWINS-model was built in exactly the same way as described in section 4. For this track also, a simplified model was made to estimate the contribution of the concrete slab to the total emitted noise. The dynamic behaviour of this track differs from that of the existing embedded rail structure; the first vertical track resonance frequency is higher (380 Hz versus 160 Hz), the elastomeric resonances take place at higher frequencies (4 kHz versus 500 Hz), and the relative vibration level of the concrete slab is also higher (more than 15 dB below the level of the rail head versus more than 30 dB).

For the reference (ballasted) track mentioned in section 3 a TWINS-model was built using a reference vehicle (a freight wagon) with measured wheel and rail roughness spectra. This model is not discussed here; comparison of the calculated sound pressure spectrum with measurements at 2 m from the track centre and 1 m above the rail head, showed a standard deviation of about 4 dB in the one-third octave band spectrum, and an overprediction of 2 dB(A) in the over-all sound pressure level. These deviations are within the accuracy of TWINS established in reference [3].

To make relevant comparisons possible, the three tracks were compared using the same wagon (the reference freight vehicle), the same train speed (100 km/h) and the same roughness spectra. For the combined wheel/rail roughness, two extreme spectra were selected (see Figure 8); one typical roughness spectrum for tread-braked trains (with a polygonization peak around 600 Hz) and one for trains that are not braked on the wheel running surface. For each of these roughness spectra, the resulting differences in the noise spectra between the three tracks are equal (for TWINS is a linear model), but the differences in the dB(A) level can be different.

For each of the three tracks combined with the "high" roughness, the resulting emission (sound power) spectra are now discussed. Figure 9 shows the total sound power and the individual contributions of rail plus moulding material, slab and wheel for the existing slab track. The rail and the moulding material produce the main noise contribution below 2 kHz; their contribution determine the dB(A) level. The contribution of the slab is negligible. For the optimized slab track (see Figure 10), the rail plus elastomer contribution is dominant between 0.5 and 1.6 kHz, whilst for lower and higher frequencies the wheel contribution dominates the total noise. The contribution of the slab, though not negligible anymore, is still considerably lower. Figure 11 shows the spectra for the ballasted track, which are rather typical; the sleeper is the dominant noise source for low frequencies (below 800 Hz), the rail for moderate frequencies (between 1 and 2 kHz), the wheel for high frequencies (above 2.5 kHz).

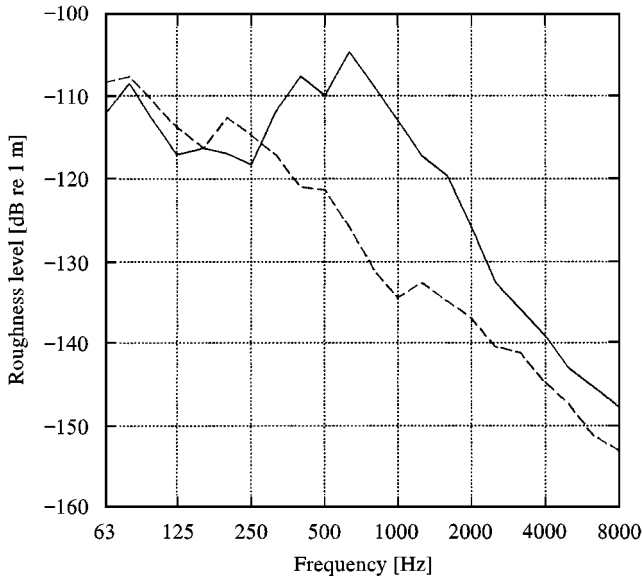

Figure 8. Typical combined wheel/rail roughness spectra at 100 km/h: tread-braked (—) and non-tread-braked trains (---).

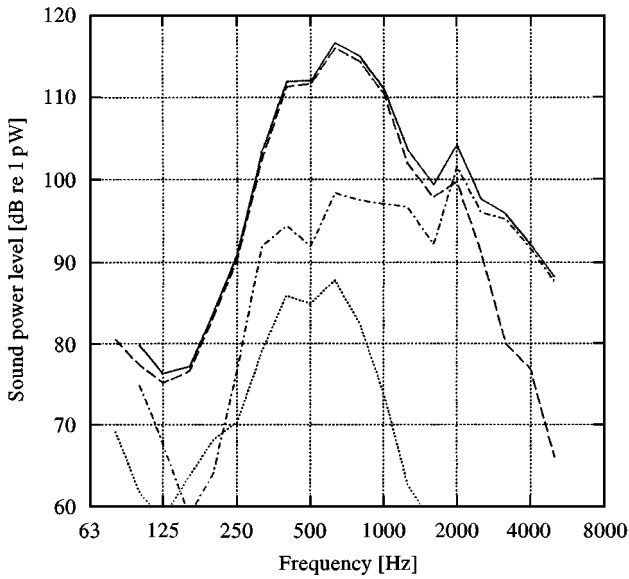

Figure 9. Calculated sound power spectrum of existing slab track with reference wagon and typical “tread-braked” roughness: total noise (—), and contributions of rail plus elastomer (---), slab (···), and wheel (- · - ·).

The dB(A)-levels are shown in Table 1 for both roughness spectra. The most interesting figure is the total noise contribution emitted by the track. It can be seen that the optimized slab track is predicted to emit between 4 and 6 dB(A) less noise than the ballasted track, where the noise reduction is larger for non-tread-braked

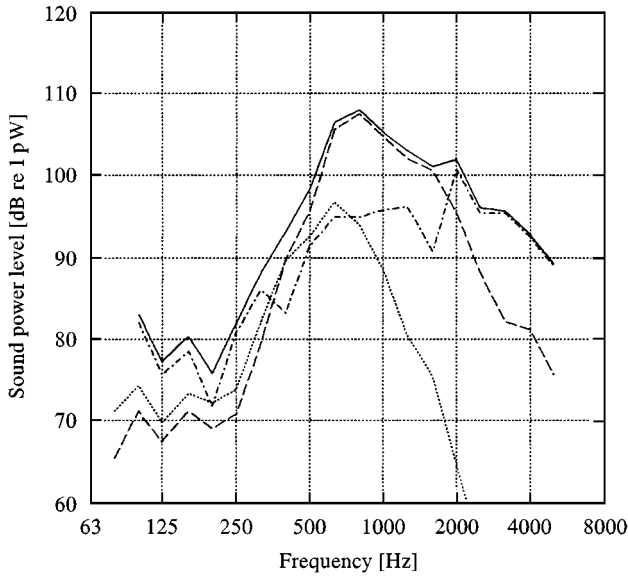

Figure 10. Calculated sound power spectrum of optimized slab track with reference wagon and typical “tread-braked” roughness: total noise (—), and contributions of rail plus elastomer (---), slab (···), and wheel (-·-·-).

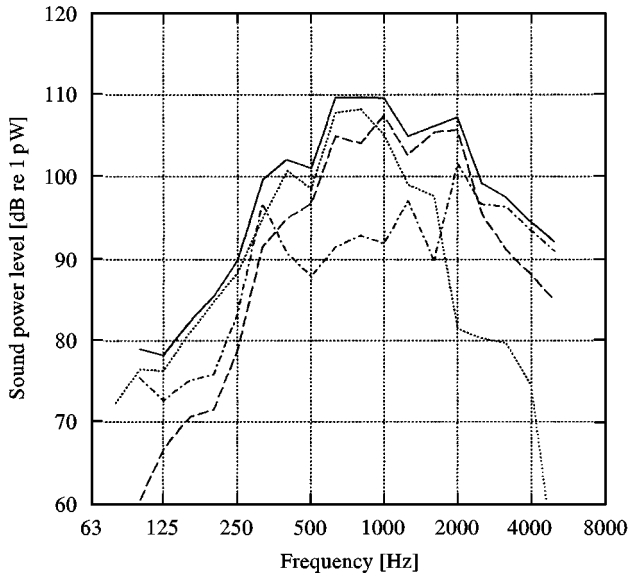

Figure 11. Calculated sound power spectrum of reference track with reference wagon and typical “tread-braked” roughness: total noise (—), and contributions of rail (---), sleeper (···), and wheel (-·-·-).

trains than for tread-braked trains. In addition, the existing slab track appears to emit between 1.5 and 3 dB(A) more noise than the ballasted track, which agrees with the pass-by measurement results. Note that the wheel contribution does not differ much between the three tracks.

TABLE 1

Calculated A-weighted sound power levels (total and contributions per source) at 100 km/h for three types of track combined with the reference wagon and two typical roughness spectra

Sound power level [dB(A)]	Tread braked trains			Non-tread braked trains		
	Optimized	Existing	Ballasted	Optimized	Existing	Ballasted
Rail and elastomer	111.5	118.8	113.5	93.6	101.6	98.9
Sleeper or slab	98.6	< 90	111.9	81.5	< 80	97.7
Total track	111.7	118.8	115.8	93.8	101.6	100.0
Wheel	106.4	107.4	106.9	96.1	96.4	97.5
Total	112.8	119.2	116.3	98.1	102.7	102.0

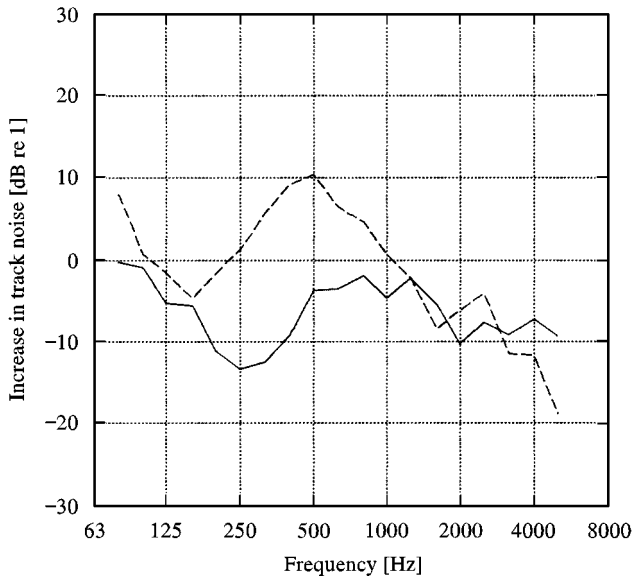

Figure 12. Increase of the noise emitted by the track relative to the reference track: optimized slab track (—) and existing slab track (- - -).

5.2. FURTHER ANALYSIS

Figure 12 shows the increase in the noise emitted from the track for both slab tracks relative to the ballasted track. The optimized slab track shows a reduction in the track noise over the entire frequency range, but especially between 200 and 400 Hz. In this frequency range, the excitation forces in the contact patch appear to be lower than for the ballasted track; this is caused by the high values of the frequency response function in this frequency range. The track would be even quieter if a greater reduction could be achieved in the dB(A) dominating frequency range, around 1 kHz (see Figure 10).

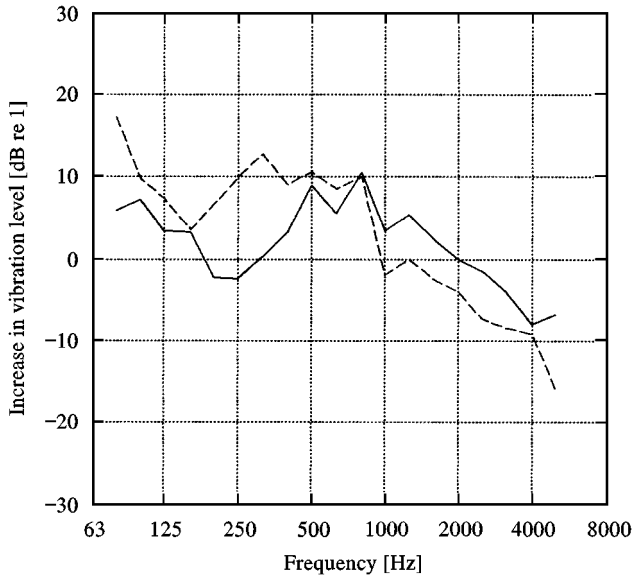

Figure 13. Increase of the vertical vibration level of the rail head relative to the reference track: optimized slab track (—) and existing slab track (- - -).

The existing slab track shows an increase of noise between 250 and 1000 Hz, the frequency range where elastomer resonances occur (see Figure 5). When comparing the increase in track noise with the increase in vertical rail head vibration levels of the slab tracks relative to the ballasted track (see Figure 13), the same shape of the spectra can be seen, but the peak between 250 and 1000 Hz is flattened. Thus, the increase in the noise spectrum in this range does not originate from the rail head; it must come from the moulding material surface. In conclusion, the resonances of the moulding material surface are responsible for the extra noise production of the existing slab track relative to the ballasted track.

6. CONCLUSIONS AND RECOMMENDATIONS

Three track types have been acoustically compared; an existing slab track with embedded UIC54 rails, a newly designed, acoustically optimized slab track with a lower rail embedded in a stiffer moulding material, and, as a reference, a ballasted track. The models of the existing tracks have been validated with measurements. Calculations indicate that the optimized slab track emits between 4 and 6 dB(A) less noise than ballasted track. The conventional slab track produces between 1.5 and 3 dB(A) more noise than the ballasted track; this increase is caused by resonances in the elastomeric moulding material in the dB(A)-level determining that part of the spectrum that determines to be dB(A) level. Further optimization of the track, including the civil engineering aspect, and for other train types and other speeds, should be investigated.

The TWINS program has been used for the calculation of the acoustic emission. Though the program was developed for ballasted track, it is possible to estimate the

noise contributions of the rail, the elastomer and the concrete slab by the combination with FEM, as described in this paper. The modelling method has validated for existing slab track with embedded rails; the model for the new slab track will be validated when the track is available.

ACKNOWLEDGMENTS

The work described in this paper has been performed within the Dutch ICES project “Stiller Treinverkeer” (silent railway traffic). The project consortium “Rail” gave permission for this publication. The vibration measurements for the existing slab track were performed by TNO-TPD, Delft, the Netherlands.

REFERENCES

1. D. J. THOMPSON 1990 *Ph.D. thesis, University of Southampton, UK*. Wheel/rail noise: theoretical modelling of the generation of vibrations.
2. D. J. THOMPSON, B. HEMSWORTH and N. VINCENT 1996 *Journal of Sound and Vibration* **193**, 123–135. Experimental validation of the TWINS prediction program for rolling noise, Part I: Description of the model and method.
3. D. J. THOMPSON, P. FODIMAN and H. MAHÉ 1996 *Journal of Sound and Vibration* **193**, 137–147. Experimental validation of the TWINS prediction program for rolling noise, Part II: Results.
4. M. H. A. JANSSENS and W. J. A. VAN VLIET 1997 *TNO Report HAG-RPT-970108*. ICES-STV consortium rail: the effect of the rail shape on the noise production for a slab track. (in Dutch, confidential).
5. A. A. VAN LIER 1998 *ISMA23 International Conference on Noise and Vibration Engineering, Leuven, Belgium*. The vibro-acoustic modelling of slab track with embedded rails.