



# RELATIONSHIP BETWEEN SUBJECTIVE PREFERENCE AND THE ALPHA-BRAIN WAVE IN RELATION TO THE INITIAL TIME DELAY GAP WITH VOCAL MUSIC

K. MOURI AND K. AKIYAMA

Central Research & Development Headquarters, Itoki Crebio Corp., 4–12, Imafuku-higashi, 1-chome, Joto-ku, Osaka 536-0002, Japan

AND

Y. ANDO

Graduate School of Science and Technology, Kobe University, Rokkodai, Nada, Kobe 657-8501, Japan

(Accepted 30 June 1999)

Previously, it was reported that the most preferred initial time delay gap  $[\Delta t_1]_p$  and subsequent reverberation time are described by the minimum value of the effective duration  $(\tau_e)_{min}$  of the running autocorrelation function (ACF) of music signals ( $2T = 2.0$  s) (Y. ANDO *et al.* 1989 *Journal of Acoustical Society of America* **86**, 644–649). This paper shows whether this result is supported or not by use of the electro-physiological method. Experiments were performed for sound fields changing the initial time delay gap  $\Delta t_1$  of a single reflection with vocal music as a source signal, which has large changes in running  $\tau_e$ . The results at the time interval when  $(\tau_e)_{min}$  of the music is observed reveal that the scale value of subjective preference is closely related to the value of  $\tau_e$  of the alpha wave obtained from the left hemisphere.

© 2000 Academic Press

## 1. INTRODUCTION

A workable model of the human auditory–brain system, which incorporates hemispheric asymmetry, was proposed by Ando [1]. It contains autocorrelators and an interaural cross-correlator for processing acoustic information [1, 2], as shown in Figure 1. It is found that the left cerebral hemisphere is specialized for temporal factors such as the initial time delay gap between the direct sound and the first reflection sound ( $\Delta t_1$ ) and reverberation time ( $T_{sub}$ ) [3–5]. The right cerebral hemisphere is associated with spatial acoustic factors: the sensation level (SL) and the magnitude of interaural cross-correlation (IACC) [3]. Thus, hemispheric specialization is considered to be one of the most fundamental functions of the brain.

In the previous investigations, it was demonstrated that the most preferred  $\Delta t_1$  is determined by the minimum value of the effective duration  $(\tau_e)_{min}$  of the source

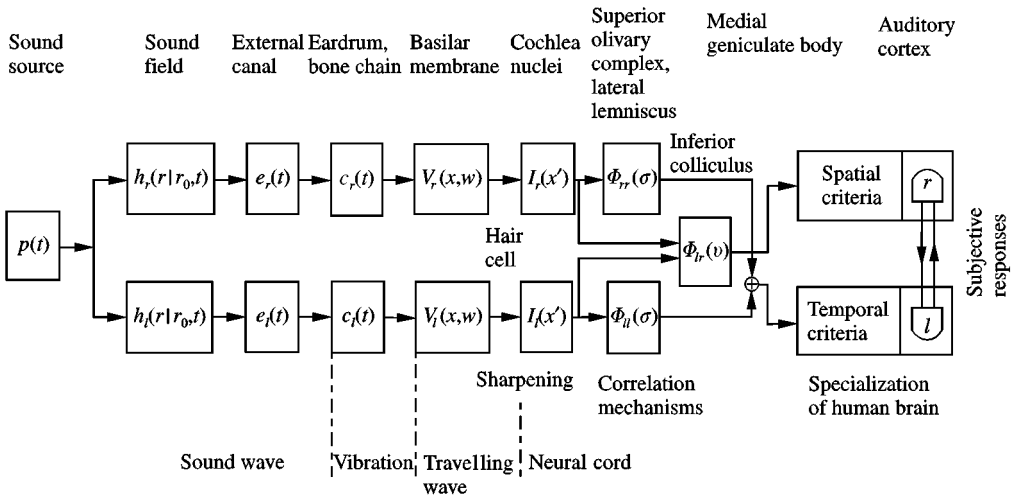

Figure 1. Model of auditory-brain system with correlation mechanisms.

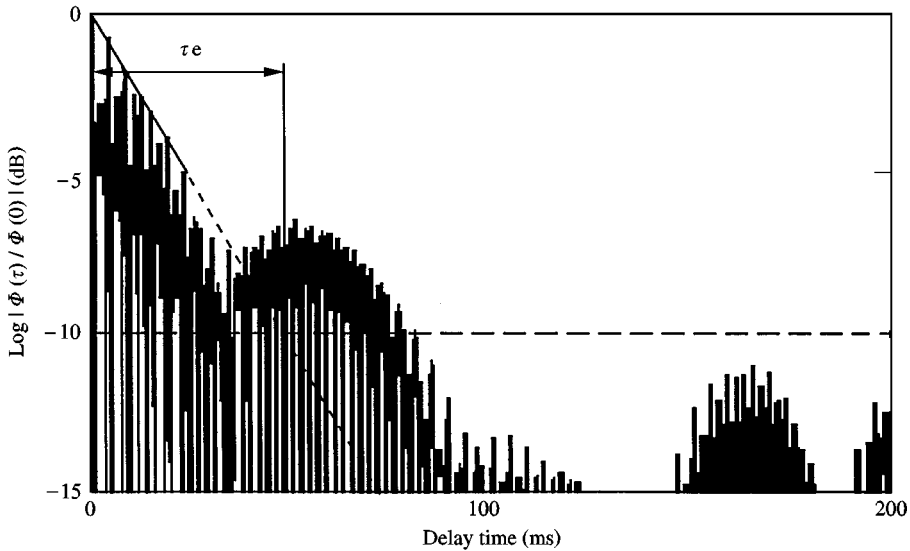

Figure 2. Example of obtaining the effective duration of running ACF.

signal when the  $A$ -value is unity [6]. The value of  $(\tau_e)_{min}$  may be found in the most rapid movement of the source signal, which may be considered to be the most sensitive part for our brain. The  $A$ -value is defined as the total amplitude of reflections and reverberation. The effective duration  $(\tau_e)$  of ACF is obtained by the delay time such that the initial decay rate between 0 to  $-5$  dB of the envelope of the normalized ACF extrapolated at  $-10$  dB, as shown in Figure 2. To obtain the running ACF, each  $\tau_e$  is calculated by moving part of the integration interval  $(2T)$  at the running interval (100ms). The interval  $(2T)$  of ACF, which is considered to correspond to the psychological present [7], must be determined. The

psychological present defined here is a short-time duration of stimuli needed for subjective responses. The duration in this study is defined as  $2T = 2.5$  s, because it is found that this value typically corresponds to the physiological response associated with subjective preference [4]. It has been discovered that the value of  $\tau_e$  of alpha-brain waves from the left temporal area is related to the scale value of subjective preference in change of both  $\Delta t_1$  and reverberation time [4, 5]. In this study, this method is utilized to demonstrate the hypothesis described below.

Namely, it is hypothesized that subjective preference is judged at the  $(\tau_e)_{min}$  of a source signal, so that the value of  $\tau_e$  of alpha-brain waves is affected typically at that part. Since  $\Delta t_1$  is considered to be processed as a temporal factor, it is assumed that a significant tendency on the left hemisphere exists.

## 2. EXPERIMENT 1

Two experiments were carried out. In experiment 1, 14 right-handed subjects (10 males and 4 females aged 25–35 yr old with normal hearing ability) were investigated to evaluate the subjective preference for  $\Delta t_1$ . The source was the initial 4 s of the vocal music motif *S* (Schubert, *Die Forelle*, performed by Ms Mikiyo Setoguchi), which was recorded in an anechoic chamber. The running  $\tau_e$  of the source signal was calculated. The value of  $(\tau_e)_{min}$  obtained is about 15 ms ( $2T = 2.5$  s), as shown in Figure 3. The five sound fields which consisted of the direct sound and a single reflection with change of  $\Delta t_1$ : 5, 10, 20, 40 and 80 ms, were prepared. Two loudspeakers were located at 1.5 m in front of the subject, and produced the direct (elevation  $0^\circ$ ) and reflection sound (elevation  $17^\circ$ ) keeping  $IACC \approx 1.0$ . The  $A$ -value was fixed at 1, and the total sound pressure level was

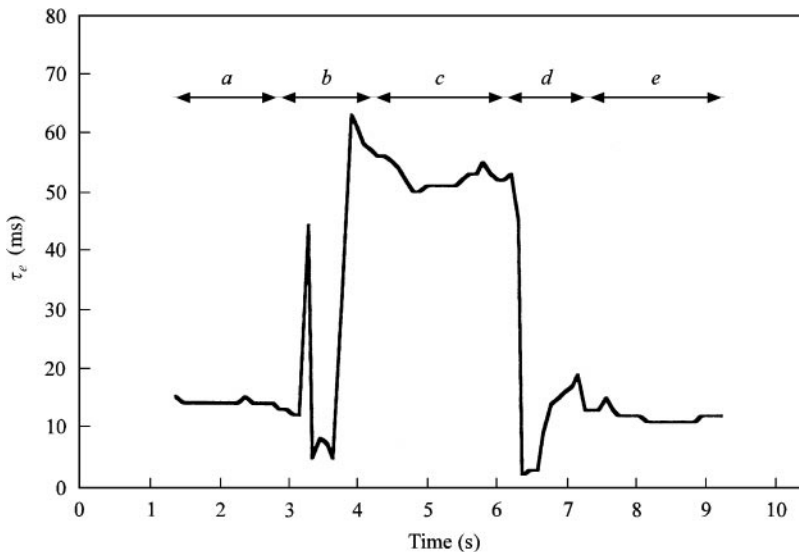

Figure 3. Values of  $\tau_e$  obtained by analysis of the running *ACF* ( $2T = 2.5$  s with the interval of 100 ms) of vocal music (motif *S*) for about 10 s beginning with the time at 1.25 s (the centre of the integration time,  $2T$ ). Parts of a–e correspond to those in Figure 7.

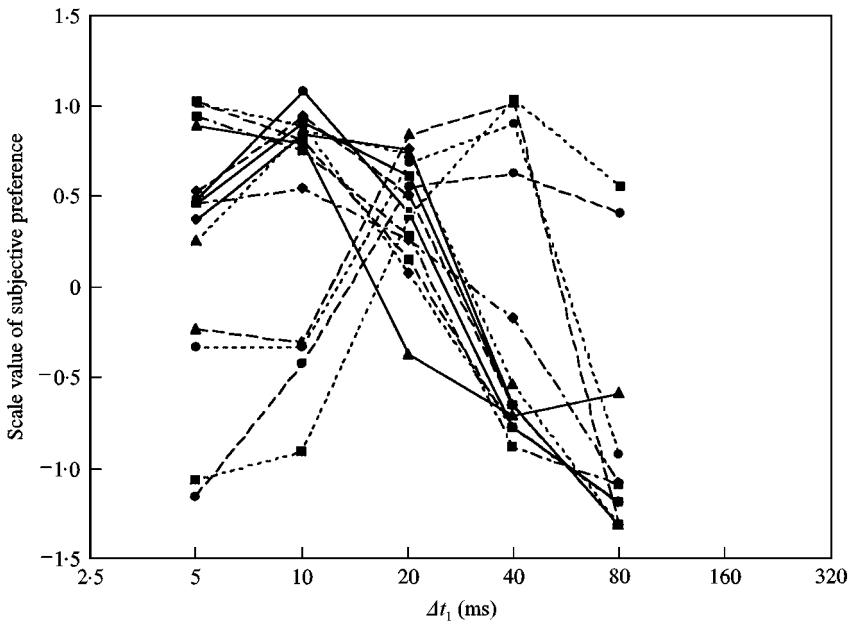

Figure 4. Scale values of subjective preference as a function of  $\Delta t_1$  for 14 subjects (Experiment 1): subjects —■—, A; —◆—, B; —▲—, C; —●—, D; —■—, E; —◆—, F; —▲—, G; —●—, H; —■—, I; —◆—, J; —▲—, K; —●—, L; —■—, M; —◆—, N.

80 dB(A) at the peak level. Paired-comparison tests were performed for all pairs of sound fields in the anechoic chamber, asking subjects to select which of two sound fields they preferred to listen to. This test was repeated 10 times for each subject. The scale value ( $SV$ ) of individual subjective preference was calculated by applying the law of comparative judgement (case V) [8], and was reconfirmed by the goodness of fit [9].

Results of the scale values of subjective reference are shown in Figure 4. The figure shows that almost all subjects preferred sound fields in the range of  $\Delta t_1$  less than 20 ms. It is worth noting that the most preferred calculated value of  $\Delta t_1$  for  $A = 1.0$  corresponds to the minimum value of  $\tau_e$  obtained by the running  $ACF$  of the music signals used for subjective preference judgements: i.e.,  $[\Delta t_1]_p \approx (1 - \log_{10} A)\tau_e \approx 15$  (ms) for global subjects [6].

### 3. EXPERIMENT 2

Ten subjects (A, B, C, D, E, F, J, K, M, N: 7 males and 3 females) were selected for the second experiment to investigate the relationship between the running  $\tau_e$  of the source signal and the  $\tau_e$  of the range of alpha-brain waves for the two sound fields which were preferred and less preferred conditions of  $\Delta t_1$ . Prior to this research, all subjects were instructed not to drink any alcohol and to refrain from smoking for the three days before the recording of the continuous brain wave ( $CBW$ ). The block diagram of the experimental set-up is shown in Figure 5. The source signal, which was a piece of the music motif  $S$  with the duration of 10 s, was given at the sound

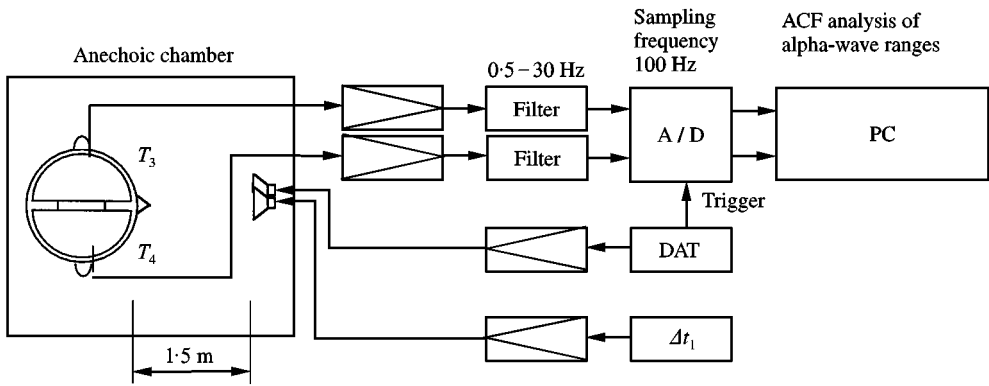

Figure 5. Block diagram of analyzing alpha waves from  $T_3$  (left) and  $T_4$  (right).

pressure level of 80 dB(A). According to the results of the selected 10 subjects (see Figure 4), the value of  $\Delta t_1$  of the preferred sound field was selected at 10 ms, and that of the less preferred sound field was 80 ms.

Each subject sat in the anechoic chamber and listened to the two sound fields alternatively. The *CBW*s from the left and right cerebral scalps were picked up by silver electrodes at  $T_3$  and  $T_4$  (International 10/20 standards [10]). The reference electrodes were positioned on both the left and right earlobes. The ground electrode was placed on the forehead. The sampling rate was 100 Hz after the low-pass filter of 30 Hz simultaneously. The alpha-wave range of *CBW* signals was analyzed by the running *ACF* similar to music signals after passing through a digital band-pass filter with cut-off frequencies (140 dB/octave slopes) of 8–13 Hz. The amplitude of the first-reflection sound corresponded to that of the direct sound, keeping  $A = 1$ .

#### 4. RESULTS AND DISCUSSION

The effects of the difference of  $\Delta t_1$ , and the difference between the left and right hemispheres (*LR*) were examined for all 10 subjects using the three-way ANOVA, as shown in Table 1. The effects of the individual differences (Subject)  $\Delta t_1$  and *LR* are all significant ( $p < 0.01$ ). In addition, there are significant interference effects among Subject,  $\Delta t_1$  and *LR* ( $p < 0.01$ ), but the interference effect between  $\Delta t_1$  and *LR* is not significant ( $p < 0.10$ ). As shown in Figure 6, it is found that the value of  $\tau_e$  in the alpha-wave range for the sound field of  $\Delta t_1 = 10$  ms is significantly greater than that of  $\Delta t_1 = 80$  ms only in the left hemisphere (*t*-test:  $p < 0.005$ ). No significant difference is found in the right hemisphere. The effects of  $\Delta t_1$  and the music parts (a–e) were examined for  $T_3$  and  $T_4$ , separately. As shown in Tables 2 and 3, the significant effect of  $\Delta t_1$  and the interference effect between the music part and  $\Delta t_1$  are obtained on the left hemisphere ( $T_3$ ), but are not obtained on the right ( $T_4$ ). Thus, it is reconfirmed that the left hemisphere is associated with the temporal factors of sound fields such as  $\Delta t_1$ . This result supports the model [1, 2], and is consistent with those of the previous investigations [4, 5]. Also, it agrees well with hemispheric specialization [3]. Hereafter, we focus on the left hemisphere.

TABLE 1

*Analysis of variance for all  $\tau_e$  in the alpha-brain waves*

Factor	df	F-value	p
Subject	9	1062.5	< 0.01
$\Delta t_1$	1	9.0	< 0.01
Subject $\Delta t_1$	9	23.1	< 0.01
LR	1	314.0	< 0.01
Subject LR	9	114.2	< 0.01
$\Delta t_1$ LR	1	3.6	< 0.10
Subject $\Delta t_1$ LR	9	14.2	< 0.01
Error	59 700		

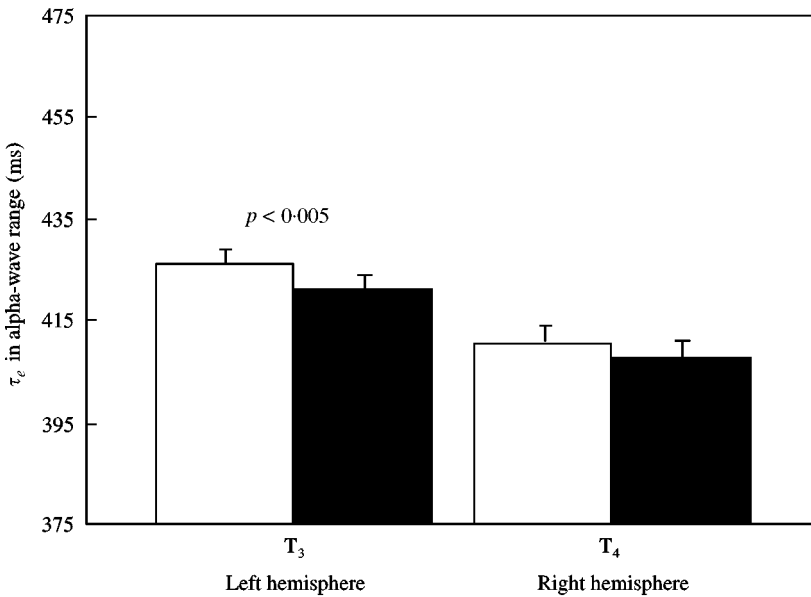

Figure 6. Averaged values of  $\tau_e$  obtained by analysis of running ACF ( $2T = 2.5$  s with the interval of 100 ms) in the alpha-wave range throughout about 10 s, under the conditions of  $\Delta t_1 = 10$  and 80 ms: □,  $\Delta t_1 = 10$  ms; ■,  $\Delta t_1 = 80$  ms.

The averaged ratios of  $\tau_e$  of all subjects at  $T_3$  (left hemisphere) between  $\Delta t_1 = 10$  and 80 ms were calculated for each part (a–e) separately, as shown in Figure 7. It is remarkable that the ratio is maximum at the part of d, and this part is in accord with the  $(\tau_e)_{min}$  of the source signal, as shown in Figure 3.

As shown in Figure 8, the averaged value of  $\tau_e$  of the alpha-brain waves for the sound field with  $\Delta t_1 = 10$  ms at the part of d is significantly greater than that of  $\Delta t_1 = 80$  ms only in the left hemisphere ( $t$ -test:  $p < 0.001$ ). This result reveals that subjective preference is closely associated with the  $(\tau_e)_{min}$  of the music signal. At the part (d), this tendency is typically reconfirmed for almost all subjects (Sign test:  $p < 0.05$ ), as shown in Figure 9.

TABLE 2

*Analysis of variance of  $\tau_e$  in the alpha-brain waves for  $\Delta t_1$  at  $T_3$  with the factors: Part (a-e),  $\Delta t_1$*

Factor	df	F-value	p
Part	4	57.4	< 0.01
$\Delta t_1$	1	7.5	< 0.01
Part $\Delta t_1$	4	9.6	< 0.01
Error	29481		

TABLE 3

*Analysis of variance of  $\tau_e$  in the alpha-brain waves for  $\Delta t_1$  at  $T_4$  with the factors: Part (a-e),  $\Delta t_1$*

Factor	df	F-value	p
Part	4	62.9	< 0.01
$\Delta t_1$	1	2.8	0.10
Part $\Delta t_1$	4	1.3	0.28
Error	30239		

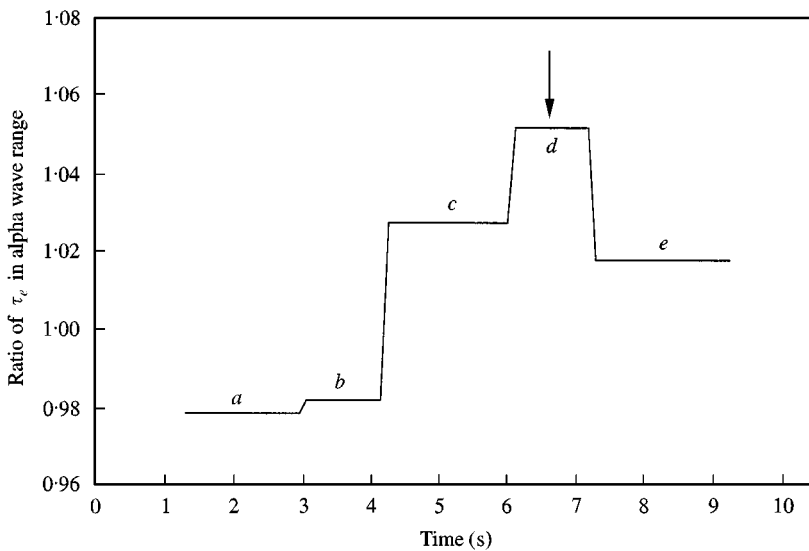

Figure 7. Ratios of the  $\tau_e$  value ( $2T = 2.5$  s) in the alpha-wave range of all subjects tested at  $T_3$  (left hemisphere) for the change of  $\Delta t_1 = 10$  and 80 ms obtained at corresponding parts of music signals: a-e which correspond to those in Figure 5.

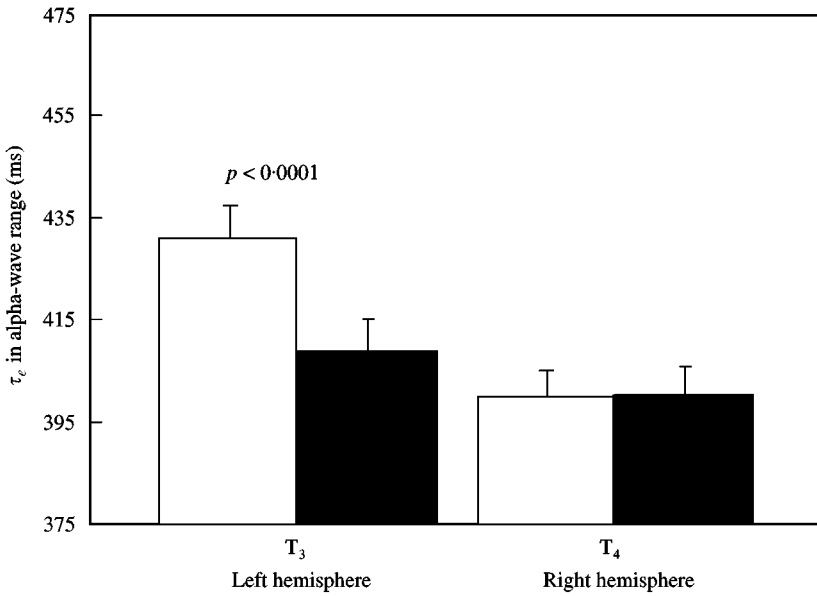

Figure 8. Averaged values of  $\tau_e$  ( $2T = 2.5$  s) in the alpha-brain wave range from the left hemisphere for music piece of d with the change of  $\Delta t_1 = 10$  and 80 ms:  $\square$ ,  $\Delta t_1 = 10$  ms;  $\blacksquare$ ,  $\Delta t_1 = 80$  ms.

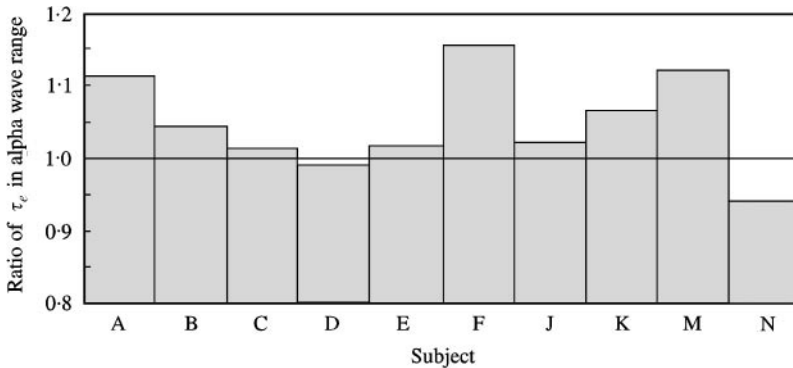

Figure 9. Ratios of the  $\tau_e$  values in the alpha-wave range for change of  $\Delta t_1$  obtained at  $T_3$  (left hemisphere):  $[(\tau_e \text{ value at } 10 \text{ ms})/(\tau_e \text{ values at } 80 \text{ ms})]$ , obtained for each individual.

### 5. CONCLUSIONS

The value of  $(\tau_e)_{min}$  of a source signal is the most important for the brain which affects subjective preference with changing temporal factor  $\Delta t_1$ . It is demonstrated that subjective preference judged at the  $(\tau_e)_{min}$  of a source signal is closely related to the value of  $\tau_e$  of the alpha-brain waves obtained from the left hemisphere. These results means that the human left hemisphere is sensitive to the most rapid movement of a source signal.



## ACKNOWLEDGMENT

The authors thank Mr Hiroshi Setoguchi and Ms Mikiyo Setoguchi for recording sound sources, and subjects for participating in this investigation.

## REFERENCES

1. Y. ANDO 1998 *Architectural Acoustics, Blending Sound Sources, Sound Fields, and Listeners*, New York: Springer-Verlag, AIP Press.
2. Y. ANDO 1983 *Journal of Acoustical Society of America* **74**, 873–887. Calculation of subjective preference at each seat in a concert hall.
3. Y. ANDO 1992 *Acoustica* **76**, 292–296. Evoked potentials relating to the subjective preference of sound fields.
4. Y. ANDO and C. CHEN 1996 *Journal of Architectural Planning and Environmental Engineering AIJ* **488**, 67–73. On the analysis of autocorrelation function of alpha-waves on the left and right cerebral hemispheres in relation to the delay time of single sound reflection.
5. C. CHEN and Y. ANDO 1996 *Journal of Architectural Planning and Environmental Engineering AIJ* **489**, 73–80. On the relationship between the autocorrelation function of the alpha-waves on the left- and right-cerebral hemispheres and subjective preference for the reverberation time of music sound field.
6. Y. ANDO, T. OKANO and Y. TAKEZOE 1989 *Journal of Acoustical Society of America*. **86**, 644–649. The running autocorrelation function of different music signals relating to preferred temporal parameters of sound fields.
7. P. FRAISSE 1982 *The Psychology and Music* (D. Deutsch editor), 149–180. Orlando, FL: Academic Press, Chapter 6. Rhythm and tempo.
8. L. L. THURSTONE 1927 *Psychology Reviews* **34**, 273–289. A law of comparative judgement.
9. F. MOSTELLOR 1951 *Psychometrika* **16**, 207–218. Remarks on the method of paired comparisons: III. A test of significance for paired comparisons when equal standard deviations and equal correlations are assumed.
10. H. H. JASPER 1958 *Electroencephalography in Clinical Neurophysiology* **10**, 371–375. The ten-twenty electrode system of the international federation.