



# VIBRATION ANALYSIS OF THIN CYLINDRICAL SHELLS USING WAVE PROPAGATION APPROACH

X. M. ZHANG, G. R. LIU AND K. Y. LAM

*Institute of High Performance Computing, 89-C Science Park Drive #02-11/12, The Rutherford,  
Singapore Science Park 1, Singapore 118261, Singapore. E-mail: zhangxm@ihpc.nus.edu.sg*

(Received 2 December 1999, and in final form 28 April 2000)

The vibration analysis of cylindrical shells using wave propagation method is presented. Results obtained using the method have been evaluated against those available in the literature. Comparison of the results by the present method and numerical finite element method is also carried out. It is possible to conclude through the comparisons that the present method is convenient, effective and accurate. The method can be easily extended to complex boundary conditions and fluid-loaded shell structures

© 2001 Academic Press

## 1. INTRODUCTION

Cylindrical shells are the practical elements of many types of engineering structures such as aeroplanes, marine crafts and construction buildings. However, the analysis of vibration characteristics of cylindrical shells is more complex than that of beams and plates. This is mainly because the motion equations of cylindrical shells together with boundary conditions are more complex. Love [1] modified the Kirchhoff hypothesis for plates and established the preconditions of the so-called classic theory of thin shells, which is now commonly known as Love's first approximation of the first kind. He then subsequently formulated a shell theory known as Love's first approximation theory and the preconditions he established soon became the foundations on which many thin shell theories were later developed. like Flugge theory [2].

Numerous methods have been developed and used to study the vibrational behaviour of thin shells. These methods range from energy methods based on the Rayleigh–Ritz procedure to analytical methods in which, respectively, closed-form solutions of the governing equations and iterative solution approaches were used [3–6]. Lam and Loy [7] used beam functions as the axial modal functions in the Ritz procedure to study the effects of boundary conditions on the free vibration characteristics for a multi-layered cylindrical shell with nine different boundary conditions. Loy *et al.* [8] applied the generalized differential quadrature (GDQ) method for solving the vibration of cylindrical shells.

On the other hand, the wave propagation in cylindrical shells have also been investigated by many researches. Harari [9] studied the wave propagation in shells with a wall joint. The discontinuity consisted of a spring-type rubber insert and the results obtained showed high-power reflection coefficients at the cut-on frequencies of various torsional waves. Fuller [10] investigated the effects of discontinuities on the wall of a cylindrical shell in vacuum on travelling flexural waves. Zhang and Zhang [11] studied the input and transmitted power flow of an infinite cylindrical shell under the excitation of line circumferential cosine forces. Zhang and White [12] studied the input power of a shell due

to point force excitation. Experiments of driving point acceleration and transfer accelerances were compared with theoretical predictions and good agreement was found in a frequency-averaged sense. Xu *et al.* [13] studied the effects of wall joint on the vibrational power flow propagating in a fluid-filled shell. Xu *et al.* [14] studied the vibrational power flow from a line circumferential cosine harmonic force into an infinite elastic circular cylindrical shell filled with fluid. An integrated numerical method along the pure imaginary axis of the complex wavenumber domain was used to analyze the response of the shell. The results of a shell with fluid were compared with those of shell in vacuum to evaluate the effect of the fluid. This research was extended to stiffened shells filled with fluid by Xu *et al.* [15].

It is well known that the natural modes of vibration of any continuous system are superposition of equal but opposite-going propagating waves. An understanding of the physics of this process can lead one to establish simple formulae for the frequencies of the free modes of vibration. In this paper, the natural mode of the cylindrical shell is treated as a combination of standing waves in the circumferential and axial directions. The circumferential standing wave is determined by its circumferential modal parameter  $n$ , and the axial standing wave is determined by its axial modal parameter  $m$ . The relation between the natural frequency with the standing wave parameters  $n$  and  $m$  is created. The axial wavenumber of standing wave is determined approximately by the wavenumber of an equivalent beam with similar boundary conditions as the shell. This method is quite simple as wavenumbers of beams with various boundary conditions can be obtained easily. This method is also a non-iterative method, it is relatively less computationally intensive and it also gives reasonably accurate natural frequencies.

## 2. METHOD

The cylindrical shell under consideration is with constant thickness  $h$ , radius  $R$  and length  $L$ . The reference surface of the shell is taken to be at its middle surface where an orthogonal co-ordinate system  $(x, \theta, z)$  is fixed. The  $x$  co-ordinate is taken in the axial direction of the shell, where the  $\theta$  and  $z$  co-ordinates are, respectively, in the circumferential and radial directions of the shell as shown in Figure 1. The displacements of the shell are defined by  $u, v, w$  in the  $x, \theta, z$  directions respectively.

The equations of motion for a cylindrical shell can be written by the Love theory as

$$\begin{bmatrix} L_{11} & L_{12} & L_{13} \\ L_{21} & L_{22} & L_{23} \\ L_{31} & L_{32} & L_{33} \end{bmatrix} \begin{Bmatrix} u \\ v \\ w \end{Bmatrix} = \begin{Bmatrix} 0 \\ 0 \\ 0 \end{Bmatrix}, \quad (1)$$

where  $L_{ij}$  ( $i, j = 1, 2, 3$ ) are the differential operators with respect to  $x$  and  $\theta$ .

The displacements of the shell can be expressed in the form of wave propagation, associated with an axial wavenumber  $k_m$  and circumferential modal parameter  $n$ , and defined by

$$\begin{aligned} u &= U_m \cos(n\theta) e^{(i\omega t - ik_m x)}, \\ v &= V_m \sin(n\theta) e^{(i\omega t - ik_m x)}, \\ w &= W_m \cos(n\theta) e^{(i\omega t - ik_m x)}, \end{aligned} \quad (2)$$

where  $U_m, V_m$  and  $W_m$  are, respectively, the wave amplitudes in the  $x, \theta, z$  directions, and  $\omega$  is the circular driving frequency.

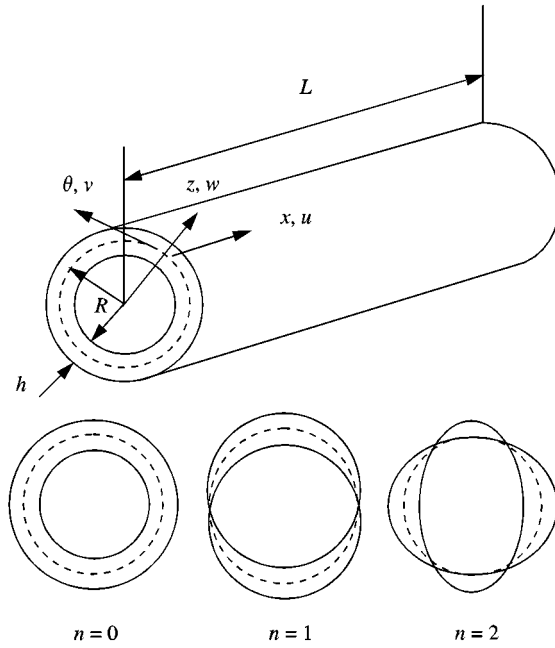

Figure 1. Co-ordinate system and circumferential modal shapes.

Substituting equation (2) into equation (1), it can be written as

$$\begin{bmatrix} C_{11} & C_{12} & C_{13} \\ C_{21} & C_{22} & C_{23} \\ C_{31} & C_{32} & C_{33} \end{bmatrix} \begin{Bmatrix} U_m \\ V_m \\ W_m \end{Bmatrix} = \begin{Bmatrix} 0 \\ 0 \\ 0 \end{Bmatrix}, \tag{3}$$

where  $C_{ij}$  ( $i, j = 1, 2, 3$ ) are the parameters from the  $L_{ij}$  after they are operated with the  $x$  and  $\theta$ . For non-trivial solutions, one sets the determinant of the characteristic matrix in equation (3) to zero

$$[C_{ij}] = 0, \quad i, j = 1, 2, 3. \tag{4}$$

Expansion of the determinant of the above equation provides the system characteristic equation

$$F(k_m, \omega) = 0, \tag{5}$$

where  $F(k_m, \omega)$  is a polynomial function. This characteristic function can be used to investigate the wave propagation in the shell as well as the natural frequency of the shell. In the first case, the frequency  $\omega$  is given, equation (5) is a bi-fourth polynomial equation and can be read as

$$k_m^8 + \alpha_1 k_m^6 + \alpha_2 k_m^4 + \alpha_3 k_m^2 + \alpha_4 = 0, \tag{6}$$

where  $\alpha_i$  ( $i = 1, 2, 3, 4$ ) are the coefficients of equation (6) from which four pairs of wavenumbers can be obtained. These wavenumbers can be separated into two groups. Each group consists of four waves. The first group contains backward waves associated with

a semi-infinite shell,  $-\infty \leq x \leq 0$  (left-hand side), excited at the edge at  $x = 0$ . The second group describes forward waves associated with a semi-infinite shell,  $-\infty \geq x \geq 0$  (right-hand side), excited at the edge at  $x = 0$ . If  $k_m$  is pure real or pure imaginary, one obtains a propagating wave or a near-field wave respectively. If  $k_m$  is complex in conjugate pairs, one obtains an attenuated standing wave, which means that the wave amplitudes decay in one direction but the waves propagate in both directions.

In this paper, equation (5) is used to obtain the natural frequencies of the finite shell. In this case, the wavenumber is given according to the required standing-wave; equation (5) can be written as

$$\omega^6 + \beta_1\omega^4 + \beta_2\omega^2 + \beta_3 = 0, \quad (7)$$

where  $\beta_i$  ( $i = 1, 2, 3$ ) are the coefficients of equation (7). Solving equation (7), one obtains three positive roots and three negative roots. The three positive roots are the angular natural frequencies of the cylindrical shell in the axial, circumferential and radial directions. The lowest of the three positive roots represents the flexural vibration, and the other two are in-plane vibrations.

The right axial wavenumber  $k_m$  must be chosen to satisfy the required boundary conditions at the two ends of the cylindrical shell, for the frequency of the shell to be obtained from equation (7). In this analysis, the wave travelling in the axial direction of the shell is simply obtained by studying the wave travelling in a similar beam.

The wave displacement  $w_b$  in the beam can be read in a general form as

$$w_b = \{a_1e^{kx} + a_2e^{-kx} + a_3e^{ikx} + a_4e^{-ikx}\} e^{i\omega t}, \quad (8)$$

where the four  $x$ -dependent terms in equation (8) are recognized as the negatively decaying evanescent wave, the positively decaying evanescent wave, the negatively propagating wave and the positively propagating wave. The  $a_i$  and the wavenumber  $k$  are determined by the boundary conditions. They can be found in relevant references, like reference [3]. For example, the simply supported–simply supported (SS–SS) boundary conditions lead to  $\sin(kL) = 0$ , so that  $kL = m\pi$ , where  $m$  is the order of the axial standing wave. Therefore, for a shell with the SS–SS boundary conditions,  $k_m = m\pi/L$  and  $n$  can be used for equation (7) to solve the natural frequency of the shell for the modal parameters ( $m, n$ ).

### 3. NUMERICAL RESULTS AND DISCUSSION

To check the accuracy of the present analysis, the results obtained are compared with those in the literature. A comparison of the values of the non-dimensional frequency parameter  $\Omega = \omega R \sqrt{(1 - \nu^2)\rho/E}$  for the case of a free vibrating cylindrical shell with the SS–SS boundary conditions is given in Table 1. In the parameter,  $E$  is Young's modulus of elasticity,  $\nu$  is the Poisson ratio,  $\rho$  is the density,  $R$  is the radius and  $\omega$  is the angular frequency. The comparisons are carried out for the parameter  $mR/L = 0.05$  and for the cases of  $h/R = 0.05$  and  $0.002$ . For the parameter  $mR/L$ , a value of  $m = 1$  is used and  $n$  are chosen from 0 to 4 in the comparison. The next comparison of the non-dimensional frequency parameter  $\Omega$  for the case of a free vibrating cylindrical shell with clamped–clamped (C–C) boundary conditions is given in Table 2. The comparison is carried out for the case of  $L/R = 20$  and  $h/R = 0.002$  where  $m = 1$  and  $2$  are used and  $n$  are selected from 1 to 5 in the comparison. The third comparison of the non-dimensional frequency parameter  $\Omega$  for the case of a free vibrating cylindrical shell with the SS–SS, the C–C, and the clamped–simply supported (C–SS) boundary conditions is given in Table 3.

TABLE 1

Comparison of values of the frequency parameter  $\Omega = \omega R \sqrt{(1 - \nu^2)\rho/E}$  for a cylindrical shell with simply supported boundary conditions ( $m = 1$ ,  $mR/L = 0.05$ ,  $\nu = 0.3$ )

$h/R$	$n$	Reference [7]	Present
0.05	0	0.0929682	0.0929586
	1	0.0161029	0.0161065
	2	0.0392710	0.0393038
	3	0.1098113	0.1098527
	4	0.2102770	0.2103446
0.002	0	0.0929298	0.0929296
	1	0.0161011	0.0161011
	2	0.00545297	0.0054532
	3	0.00504148	0.0050418
	4	0.00853383	0.0085340

TABLE 2

Comparison of values of the frequency parameter  $\Omega = \omega R \sqrt{(1 - \nu^2)\rho/E}$  for a cylindrical shell with clamped-clamped boundary conditions ( $h/R = 0.002$ ,  $L/R = 20$ ,  $\nu = 0.3$ )

$m$	$n$	Reference [3]	Reference [7]	Present
1	1	0.03440	0.03440	0.03487
	2	0.01204	0.01203	0.01176
	3	0.007222	0.007222	0.007083
	4	0.009048	0.009047	0.009016
	5	0.01377	0.01377	0.01377
2	1	0.08484	0.08484	0.08742
	2	0.03162	0.03162	0.03155
	3	0.01603	0.01603	0.01586
	4	0.01233	0.01233	0.01224
	5	0.01484	0.01484	0.01482

The comparison is carried out for the case of  $L/R = 20$  and  $h/R = 0.01$ . In the comparison,  $m = 1$  is used and  $n$  is chosen from 1 to 10. As one can see from the comparisons, very good agreement with those in the literature is obtained.

In this paper, the finite element method is also used to verify the proposed method. In the numerical model, the length, radius and thickness of the shell are, respectively, 20, 1 and 0.01 m. The shell is made of steel with mass density  $\rho_1 = 7850 \text{ kg/m}^3$ , the Poisson ratio  $\nu = 0.3$  and Young's modulus  $E = 2.1 \times 10^{11} \text{ N/m}^2$ . The shell surface is meshed with 2000 shell elements. The shell is fully clamped at its boundaries. The number of nodes is 2040. Natural frequencies of the shell were calculated using MSC/NASTRAN [16]. Table 4

TABLE 3

Comparison of values of the frequency parameter  $\Omega = \omega R \sqrt{(1 - \nu^2)\rho/E}$  for simply supported–simply supported (SS–SS), clamped–clamped (C–C), and clamped–simply supported (C–SS) cylindrical shells ( $m = 1$ ,  $L/R = 20$ ,  $h/R = 0.01$ ,  $\nu = 0.3$ )

n	SS–SS		C–C		C–SS	
	Reference [8]	Present	Reference [8]	Present	Reference [8]	Present
1	0.016101	0.016101	0.032885	0.034879	0.023974	0.024721
2	0.009382	0.009382	0.013932	0.014052	0.011225	0.011281
3	0.022105	0.022105	0.022672	0.022725	0.022310	0.022335
4	0.042095	0.042095	0.042208	0.042271	0.042139	0.042166
5	0.068008	0.068008	0.068046	0.068116	0.068024	0.068054
6	0.099730	0.099731	0.099748	0.099823	0.099738	0.099771
7	0.137239	0.137240	0.137249	0.137328	0.137244	0.137279
8	0.180527	0.180527	0.180535	0.180617	0.180531	0.180569
9	0.229594	0.229596	0.229599	0.229684	0.229596	0.229636
10	0.284435	0.284438	0.284439	0.284526	0.284437	0.284478

TABLE 4

Comparison of frequency for a clamped–clamped cylindrical shell between finite element method and present method ( $L = 20$  m,  $R = 1$  m,  $h = 0.01$  m)

Frequency (Hz)				
Order	FEM	Present	Difference (%)	Modal shape ( $m, n$ )
1	12.25	12.17	0.65	(1, 2)
2	19.64	19.61	0.15	(1, 3)
3	23.18	23.28	0.43	(2, 3)
4	27.69	28.06	1.33	(2, 2)
5	31.6	31.98	1.20	(3, 3)
6	36.7	36.47	0.63	(1, 4)
7	37.55	37.37	0.48	(2, 4)
8	39.87	39.78	0.23	(3, 4)

shows the comparison of first eight frequencies of the shell obtained by the MSC/NASTRAN and the present method. The differences of the frequencies between the two methods are very small. They are less than 2%, so the proposed method is correct and its results are reliable and accurate.

#### 4. CONCLUSION

The artical has presented the analysis of cylindrical shells using wave propagation method. Results obtained using the method have been evaluated against those available in the literature and the agreement has been found to be good. Comparison of the results by the present method and numerical finite element method was also carried out. A finite element model for a cylindrical shell was created. The shell was fully clamped at both ends.

The first eight natural frequencies were obtained with the MSC/NASTRAN. These results were compared with the present method and the agreement between them was good. Through the comparisons it is possible to conclude that the present method is convenient, effective and accurate. The method can be easily extended to complex boundary conditions and fluid-loaded shell structures.

## REFERENCES

1. A. E. H. LOVE 1952 *A Treatise on the Mathematical Theory of Elasticity*. Cambridge: Cambridge University Press, fourth edition.
2. W. FLUGGE 1962 *Stresses in Shells*. Berlin: Springer.
3. R. D. BLEVINS 1979 *Formulas for Natural Frequency and Mode Shape*. New York: Van Nostrand Reinhold.
4. A. E. ARMENAKAS, D. GAZIS and G. HERRMANN 1969 *Free Vibration of Circular Cylindrical Shells*. Oxford: Pergamon Press.
5. I. MIRSKY and G. HERRMANN 1957 *Journal of the Acoustical Society of American* **19**, 1116–1124. Nonaxially symmetric motions of cylindrical shells.
6. A. A. KHDEIR and J. N. REDDY 1990 *Computers and Structures* **34**, 817–826. Influence of edge conditions on the modal characteristics of cross-ply laminated shells.
7. K. Y. LAM and C. T. LOY 1995 *Journal of Sound and Vibration* **188**, 363–384. Effects of boundary conditions on frequencies of a multi-layered cylindrical shell.
8. C. T. LOY, K. Y. LAM and C. SHU 1997 *Shock and Vibrations* **4**, 193–198. Analysis of cylindrical shells using generalized differential quadrature.
9. A. HARARI 1978 *Shock and Vibration Bulletin* **48**, 53–61. Wave propagation in a cylindrical shell with joint discontinuity.
10. C. R. FULLER 1981 *Journal of Sound and Vibration* **75**, 207–228. The effect of wall discontinuities on the propagation of flexural waves in cylindrical shells.
11. X. M. ZHANG and W. H. ZHANG 1990 *Proceedings of ASME PVP*. New Orleans, USA. Vibrational power flow in a cylindrical shell.
12. X. M. ZHANG and R. G. WHITE 1993 *The 4th International Congress on Intensity Techniques, France*. Vibrational power input to a cylindrical shell due to point force excitation.
13. M. B. XU, X. M. ZHANG and W. H. ZHANG 1999 *Journal of Sound and Vibration* **224**, 395–410. The effect of wall joint on the vibrational power flow propagation in a fluid-filled shell.
14. M. B. XU and X. M. ZHANG 1998 *Journal of Sound and Vibration* **218**, 587–598. Vibrational power flow in a fluid-filled cylindrical shell.
15. M. B. XU, X. M. ZHANG and W. H. ZHANG 1999 *Journal of Sound and Vibration* **222**, 531–546. Space-harmonic analysis of input power flow in a periodically stiffened shell filled with fluid.
16. THE MACNEAL-SCHWENDLER CORPORATION 1996 *MSC/NASTRAN User's Manual*. Version 69, USA.